



AALBORG UNIVERSITY
DENMARK

Aalborg Universitet

Faroe Islands Wind-Powered Space Heating Microgrid Using Self-Excited 220 kW Induction Generator

Thomsen, Bjarti; Guerrero, Josep M.; Thogersen, Paul

Published in:
I E E E Transactions on Sustainable Energy

DOI (link to publication from Publisher):
[10.1109/TSTE.2014.2339373](https://doi.org/10.1109/TSTE.2014.2339373)

Publication date:
2014

Document Version
Early version, also known as pre-print

[Link to publication from Aalborg University](#)

Citation for published version (APA):
Thomsen, B., Guerrero, J. M., & Thogersen, P. (2014). Faroe Islands Wind-Powered Space Heating Microgrid Using Self-Excited 220 kW Induction Generator. I E E E Transactions on Sustainable Energy, 5(4), 1361-1366. <https://doi.org/10.1109/TSTE.2014.2339373>

General rights

Copyright and moral rights for the publications made accessible in the public portal are retained by the authors and/or other copyright owners and it is a condition of accessing publications that users recognise and abide by the legal requirements associated with these rights.

- ? Users may download and print one copy of any publication from the public portal for the purpose of private study or research.
- ? You may not further distribute the material or use it for any profit-making activity or commercial gain
- ? You may freely distribute the URL identifying the publication in the public portal ?

Take down policy

If you believe that this document breaches copyright please contact us at vbn@aub.aau.dk providing details, and we will remove access to the work immediately and investigate your claim.

Faroe Islands Wind-Powered Space Heating Microgrid Using Self-Excited 220 kW Induction Generator

Bjarti Thomsen, Josep Guerrero, *Senior Member, IEEE*, and Paul Thøgersen, *Senior Member, IEEE*

Abstract--Energy is fundamental to modern society. Increase in the oil price as well as environmental concerns have spurred the use of alternative renewable energy sources. In the Faroe Islands the readily available wind energy is an obvious source for space heating. Seasonal correlation exists between wind energy and required space heating and mismatches can be reduced by using simple water tanks as heat storages. A traditional Danish induction generator wind turbine has been erected on the island of Nólsoy to produce energy for space heating. The system is designed as a stand-alone Microgrid which needs its own control of frequency and voltage. A micro-controller is used to control frequency by matching load (heaters) to generated power and to produce the correct reactive power and voltage by switched capacitors. One challenge is the startup procedure at high winds speeds when nominal speed tend to be reached before voltage builds up by the self-excitation process. This paper reports the initial test and adaptation of the control system.

Index Terms--Microgrid, wind energy, induction generator, self-excitation, space heating.

I. INTRODUCTION

Since the early successful drilling for oil beginning in Titusville, Pennsylvania in 1859, the convenient and energy rich oil has been the world's dominant fuel and oil is still fundamental to modern society. The increase in oil prices in 1973-74 and again in 1979, spurred a quest for alternative energy sources. In recent years further price increase of oil, together with the concern for the environment, has further encouraged the development of alternative sustainable and renewable energy resources.

This picture is also valid for the remote Faroe Islands situated in the middle of the North East Atlantic and inhabited by 49,000 people. The economy hinge on the fisheries and its modern fishing fleet and land based fish factories as well as all transport are heavily dependent on oil as fuel. Also all space heating in the islands, which is necessary year round due to the harsh and relative cold climate, has relied on oil since the shift from peat cutting around 50 years ago. The import of oil is a huge economic burden on the islands with an expense reaching 174 million € in 2012 (a quarter of total export value). The economic reason as well as the Faroese authority commitment to participate in worldwide reduction of 'green house' gases demands a reduction in the import and use of oil.

Wind energy has become one of the viable alternatives. Although known and used from ancient times, modern wind energy did not become commercially viable for electric power generation until after its successful development in Denmark from the mid-1970s, securing Denmark leadership within this technology for the decades to come.

The Faroe Islands are 'blessed' with world record wind energy. In many locations average wind speed is above 10 m/s and wind turbines will typically produce energy with around 50% capacity factor. Albeit fluctuating, the average wind energy has more than double magnitude in winter (wind speeds mainly 10-15 m/s) compared to summer (5-10 m/s). This compares nicely to the required space heating energy, which is also more than double in winter compared to summer, see Fig. 1.

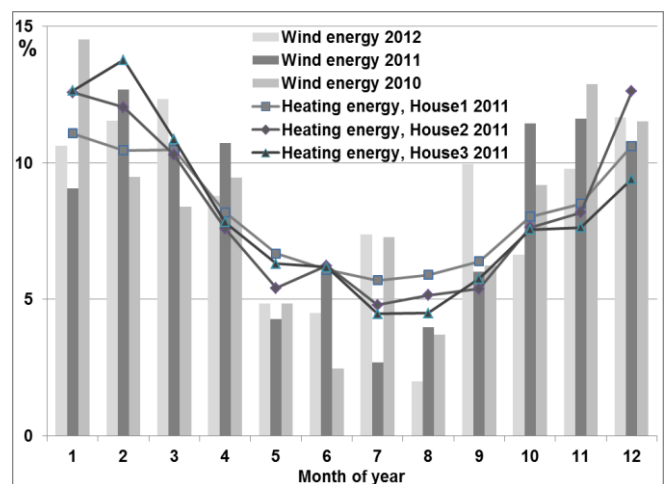

Fig. 1. Wind energy production 2010-2012 calculated from wind speed measurements and wind turbine power curve compared to measured heating energy demand in three different homes in 2011.

The wind is a variable and highly fluctuating energy source and the inability to control the amount of energy generated, remains a fundamental problem. To solve this problem an energy storage is needed. Existing large scale electric energy storage techniques are inefficient and expensive. Storage of heat energy on the other hand is simpler, and can be efficiently done in warm water tanks.

The excellent match between seasonal available wind energy and space heating requirement throughout the year and the simple storage solution are obvious reasons to use wind energy for space heating in the Faroe Islands. Based on these facts it was decided to establish a wind-space heating project on the island of Nólsoy, a Faroese remote village inhabited by 250 people in 100 households.

The idea to use wind for space heating is not new and a number of installations have been seen over the years, see e.g. [1]. However, most community size systems are combined wind-diesel generation. The idea on Nólsoy was to use traditional Danish version induction generator wind turbines, as they are readily available and cheap, because they are dismantled in high numbers from their sites to give

place for new and larger turbines.

As the local Nólsoy grid is weak, and the process to get permission to connect a wind turbine to the grid is complicated, it was decided to operate the wind turbine in a stand-alone Microgrid. In order to do this, the generator is operated as a self-excited induction generator (SEIG), which requires a reliable and accurate control system to keep nominal frequency and voltage while running in variable wind and load conditions.

Overview of SEIG research is given in [2] and [3]. The self-excitation process has been studied both by experiments and by modeling [4]-[6] and a range of control strategies for the use of SEIG have been suggested [7]-[19].

The output voltage and frequency of a SEIG are totally dependent on the system to which it is connected, in this case to the Microgrid. Self-excited means that there is no field control and therefore no voltage control, instead the residual magnetism in the rotor is used together with carefully chosen capacitors at its terminal to form a resonant condition that contributes to the voltage limited by the saturation of the stator. Once this steady point is reached any load change will cause voltage deviation [3].

On the other hand, the frequency is highly dependent on the speed of the rotor, so that unless there is a fixed speed prime mover, the Microgrid will see a frequency that changes with the prime mover and drops down when the load increases. Consequently, generator frequency can be controlled by variation in load or adding variable dummy load [11], [13]. Similarly voltage can be controlled by variation in reactive power supply either by simple switched capacitors [7], switched reactors or by using power electronics such as Static Compensators (STATCOM) [16]. However, SEIG operation is usually used only for small generators [9] and using a 220kW wind generator in SEIG mode is a challenge.

All these inconveniences, especially those related to frequency and voltage stability may be overcome by using a double feed induction generator (DFIG), however in this work, the cost of a DFIG was not affordable, being more suitable the use of a second hand SEIG-based wind turbine, which has been pointed out as a practical solution for islanded electrical systems and microgrids [5], [6].

This paper describes the initial test and adaptation of the control system for frequency and voltage stabilizations in the 220kW self-excited induction generator in the stand-alone wind turbine installation at Nólsoy.

II. NÓLSOY MICROGRID CONFIGURATION

The wind turbine acquired for the Nólsoy project is a low cost second hand traditional stall regulated Danish version wind turbine with a three phase 690V, 50Hz, 220kW squirrel cage induction generator. It was built at the former Wind World factory in Skagen in the early 1990s, and has been running in Denmark for the past 20 years.

Calculated from three year wind measurements the 220 kW wind turbine is expected to produce 870,000 kWh annually. From heating oil measurements an average family residential home is expected to use 25,000 kWh annually for heating. The 220 kW wind turbine will thus produce heating for around 35 houses.

Albeit excellent seasonal correlation between wind energy and heating (Fig. 1), an energy storage will be needed to counteract short time fluctuations in both wind energy and heating demand. Simulations using data on wind energy and heating demand indicate, that an energy storage of 100 kWh per house (which corresponds to a 2000 liter warm water tank heated from 55°C to 95°C) will result in 85% wind penetration. In an average year wind curtailment of 15% will be seen and 15% backup heating power will be needed. Larger storage will increase wind penetration, but storage size is limited by practical considerations.

The traditional Danish stall regulated wind turbines were designed to be connected to and controlled by the fixed frequency (50Hz) grid, and operate at fixed speed. According to the manual the 220kW generator requires 86 kVAr reactive power at no load and 136 kVAr at full load. When connected to the grid a fixed 75 kVAr capacitor bank was connected and the necessary variation in reactive power was provided by the grid.

In the current stand-alone system the variable reactive power is supplied using relays to connect/disconnect several small steps of capacitors to the generator terminals. Similarly the active power load is matched to the available wind energy to keep a steady frequency (which is proportional to turbine revolutions). This is done by switching water heaters (resistive load) in and out from the system. The Microgrid system is depicted in Fig. 2.

To control the switching of capacitors and heaters a 16Mhz Arduino Uno R3 control board, which include microcontroller ATmega328, is used. The generator AC output is fed via a transformer to the analog input of the controller. From this signal both the voltage and the frequency can be measured by high speed sampling. Digital outputs of the controller are used to activate relays to switch capacitors and heaters in and out to keep the nominal voltage and frequency. The number of heaters (amount of load) connected to the generator terminals is determined from the frequency and similarly the number of capacitors connected is regulated according to the voltage signal.

Initially the Arduino controller was programmed with an algorithm that kept the voltage and frequency within a band around 690V and 50Hz by counting number of connected capacitors and heaters up and down. Later conventional PID control algorithms were introduced, one controlling amount of capacitor using voltage as input and another controlling size of load using frequency as input. PID control algorithms can be found in the official Arduino programming library [20].

The microcontroller program measured the average frequency and voltage over 10 periods (200ms) to have a stable input for decision on which digital outputs to be set to control the appropriate number of capacitors and heaters to connect/disconnect. Including time for calculation and printout the control routine cycle was around 260ms, which meant that the active and reactive power was adjusted less than four times per second. This proved to be too slow during the transient startup with a sudden self-excitation. Later the program was optimized to allow for more frequent adjustments (every 62ms).

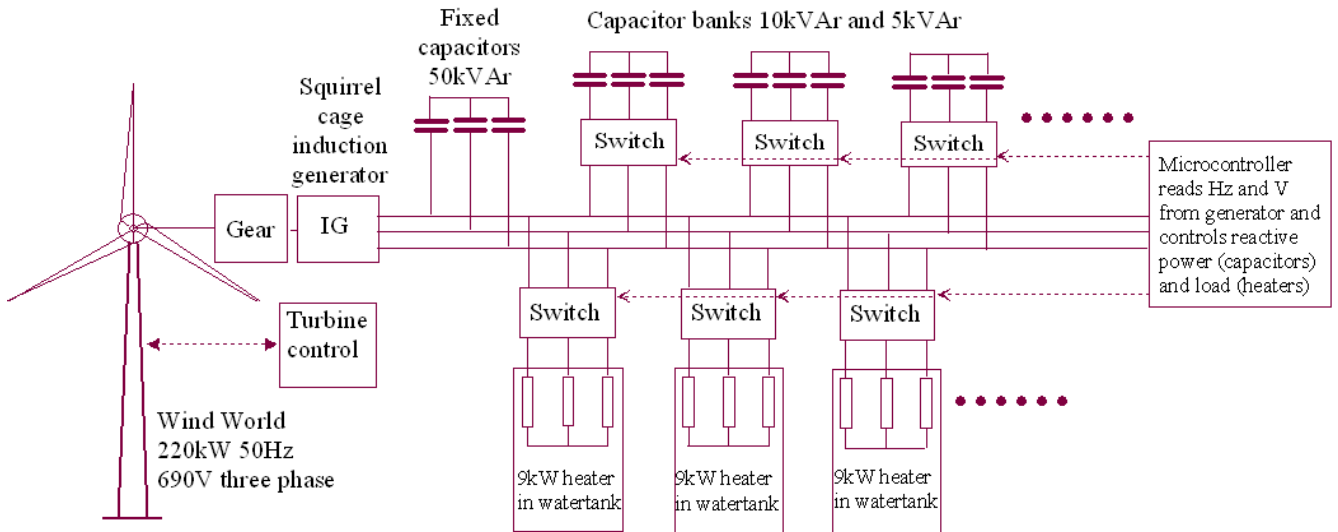

Fig. 2. Induction generator wind turbine connected to a variable number of capacitors for reactive power supply and heaters as load. A microcontroller monitors the voltage and frequency and connects/disconnects the appropriate number of capacitors and heaters.

For data logging the measured data on voltage and frequency as well as number of connected capacitors and heaters is fed to a PC for storage. During later tests wind speed information has also been logged.

III. EXPERIMENTAL RESULTS

The initial trial from November 2012 shows that frequency (which is proportional to turbine revolution) can be controlled by matching the fluctuating production with variable load using fast switched water heaters. Similarly the voltage level can be controlled by adjusting the reactive power using fast switching capacitors, see Fig. 3.

The initial self-excitation during the startup procedure proves to be the most difficult challenge. When the wind turbine brake is released the wind turns the rotor with an increasing speed. The generator is self-excited and voltage builds up depending on time and turbine speed. A too slow control routine resulted in voltage spikes (overshoot). To achieve faster response of capacitor switching the control routine had to be improved and made quicker.

With increasing wind speeds it was experienced, that the self-excitation process was too slow to reach the nominal voltage before the nominal frequency was reached, see figure 4. Connecting additional capacitors during the startup procedure proved to be beneficial. However, startup procedures in very high wind remain to be solved.

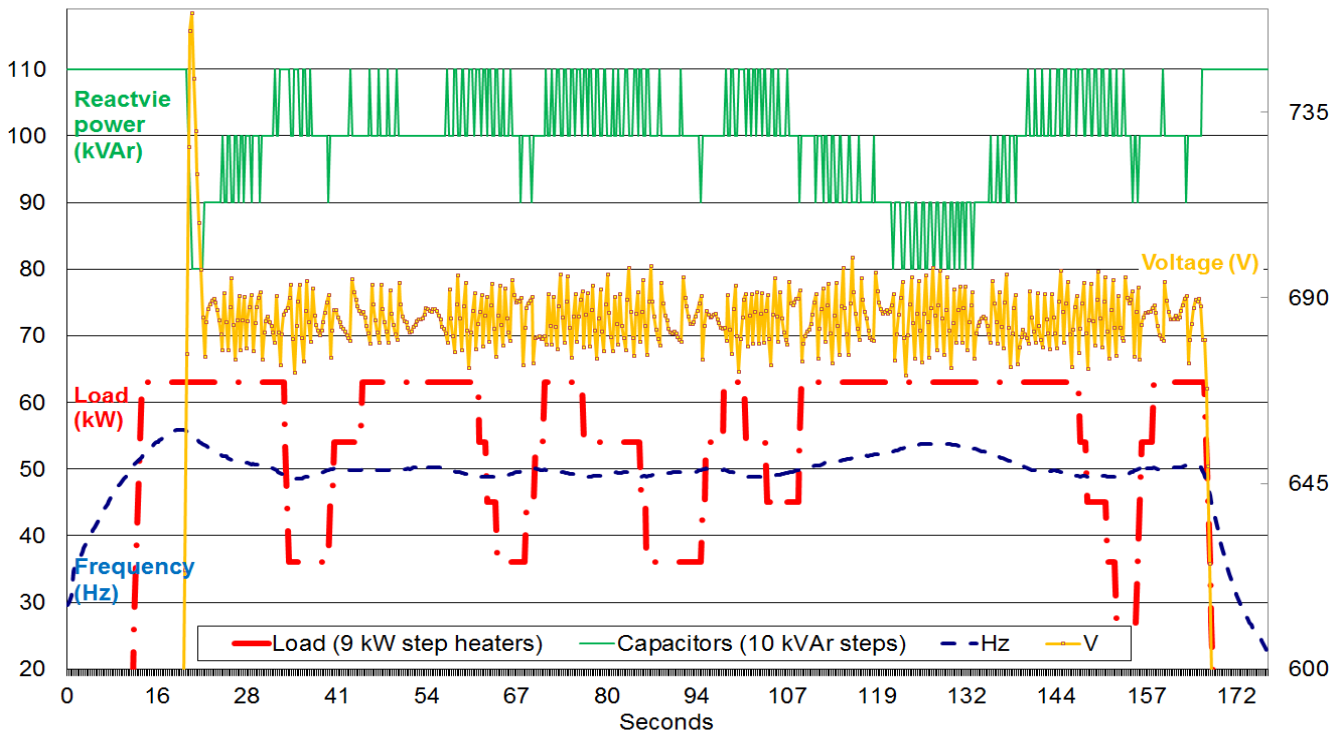

Fig. 3. Initial test in November 2012 showing frequency (Hz), voltage (V), heater load (kW) and capacitor reactive power (kVAr). Wind speed was 7-10m/s. An initial overshoot in voltage (759V) and frequency (55.9Hz) is seen. Nominal voltage is obtained after the nominal frequency is reached. For this test only 63kW load (7x9kW heaters) was available. At 110-145 seconds the load is too small (63kW) to match the wind resulting in a temporary frequency (turbine speed) increase.

At startup heaters (load) are connected in an appropriate number to tune the frequency in on 50 Hz. If the self-excitation is slow and nominal speed is reached before voltage has been built up it is difficult to avoid over-speed of the turbine. Firstly the load depends on the voltage and the heaters have little effect if the voltage is low. Secondly the connection of load does affect the self-excitation process.

Switching of capacitor banks with the minimum step size of 10 kVAr resulted in voltage fluctuation, see Fig. 3. Introduction of smaller steps of 5 kVAr reduced these fluctuations, see Fig. 5.

Using the existing standard electro mechanical relays for heaters and capacitors proved to be a problem. These relays have limited durability, and the frequent switching takes a severe toll on their lifetime with early failure as a result. For the later tests thyristor based solid state relays had to be used.

With an improved control routine the initial overshoot in voltage and frequency has been avoided, see Fig. 5.

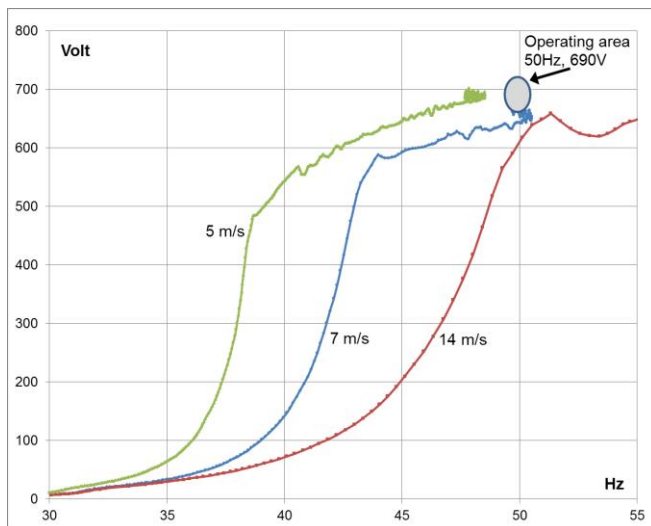

Fig. 4. Self-excitation process in the 220kW wind power induction generator at different wind speeds.

IV. DISCUSSIONS

Squirrel cage induction generators are widely used as they are relatively small and cost effective with simple and rugged construction with brushless rotor which results in reliability and reduced maintenance. They do not need DC exciter like synchronous generators and are also self-protecting against severe overload and short circuit. However, they have poor voltage regulation with changing speed and load condition. They are used in grid connected power generating systems up to 500kW but usually do not go much beyond 15kW in stand-alone self-excited mode [9]. The current initial test shows that it seems feasible to run a SEIG with a power rating as high as 220kW.

To ensure self-excitation a particular capacitance value has a corresponding minimum speed [6]. To force an early self-excitation to achieve the nominal voltage when (and preferably before) nominal speed is reached it is necessary to have extra capacitors connected during start-up. As the voltage has a sudden increase at startup the additional capacitance has to be disconnected swiftly to avoid too high

voltage peaks. It should be remembered, that uncontrolled self-excitation may pose safety problems to users [7]. In the initial tests the control routine cycle was 260ms. This is far too slow to handle the startup transient event.

When using the fluctuating wind energy as the prime mover the adjustment of capacitors and heaters have to have fast response to match the fluctuations. Traditional electromechanical contactors are not built for this frequent state change and therefore electronic thyristor based solid state relays have to be used. The fast switching of capacitors are specially challenging as there is no time for discharging as is used in conventional reactive power compensation systems to avoid current spikes. To minimize these difficulties zero crossing switching technique (turn on at zero voltage difference between capacitor and power line and turn off at zero current) proves to be beneficial.

Capacitor steps of 10 kVAr resulted in frequent switching and high variation in voltage level whereas a reduced step of 5 kVAr showed a more stable voltage level.

Obviously to run the system satisfactorily it is necessary to have sufficient load to match the maximum output from the generator at any time. Otherwise the frequency will increase and over-speed of the turbine may be experienced. Another result may be increased voltage (if capacitors are not disconnected) as produced reactive power from the capacitors is proportional to the frequency. On the other hand a controlled voltage increase with increased frequency may be beneficial as this also will increase the load from heaters and counteract over-speed.

The frequent switching of capacitors and resistor load may cause harmonic distortion in the power lines. This has not been studied yet but similar systems turned out to exhibit satisfactory performance [7], [11]. The loads used here (heaters) are very robust against bad quality of the grid parameters (voltage, frequency and harmonics).

The current 220kW wind turbine will supply heating to 35 houses. The system may be extended as it seems feasible to run two or more SEIG in parallel [3], [15].

V. CONCLUSION

The initial test of the generator in the stand-alone wind-heating system turned out to be encouraging and further development of the control system is expected to result in a safe start-up and stable running of the wind turbine.

Electrical heaters are simple and cost efficient energy converters and are one of few loads that can be as responsive to match the fluctuating wind energy.

The technology tested in this project has the potential to convert the bulk of Faroese space heating from current oil burners to sustainable wind power. The amount of wind penetration will depend on size of heat storages and backup systems will be needed during long low or no wind periods.

In many areas worldwide similar systems can be used to utilize wind energy for space heating, space cooling, water pumping or other applications with natural storage capacity.

Also the concept of a stand-alone wind driven induction generator wind turbine Microgrid stabilized by a fast response load may have interest in many rural areas throughout the world.

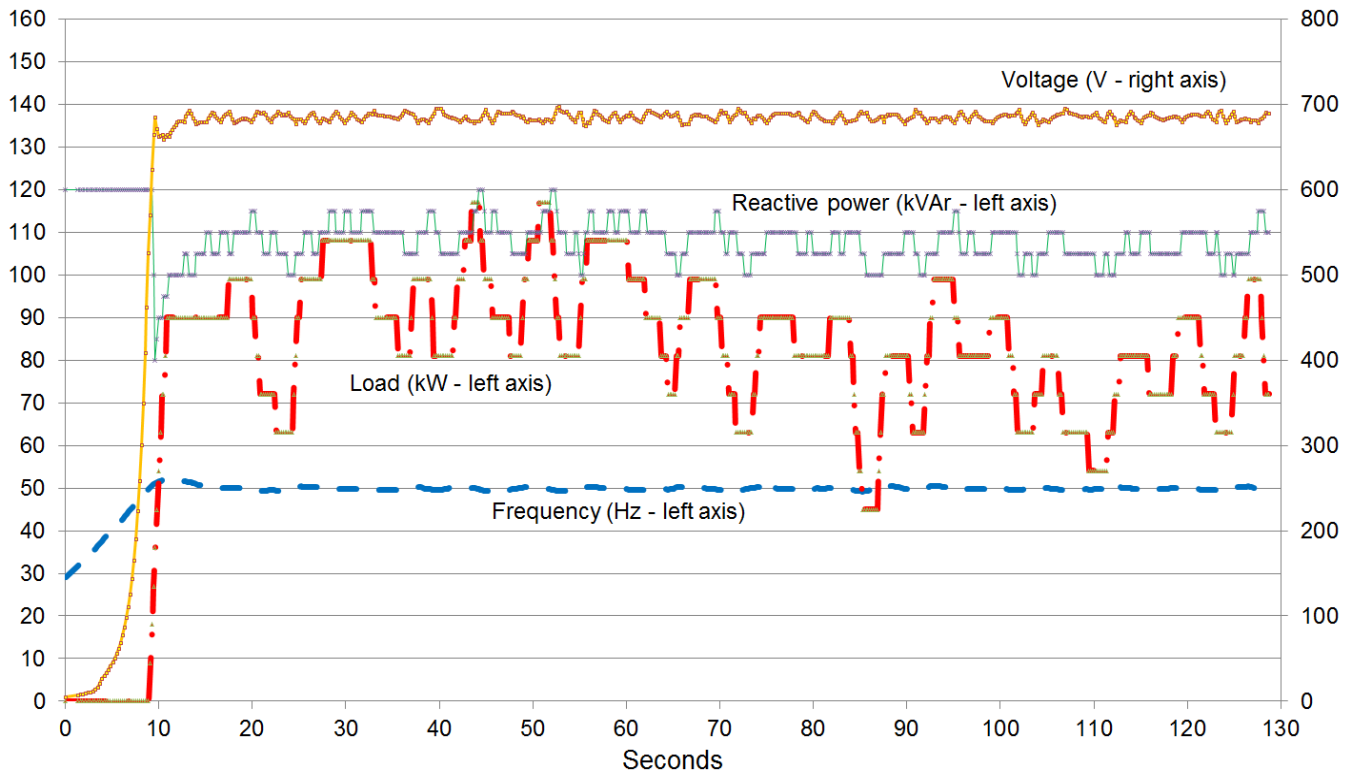

Fig. 5. Test in May 2013. Wind speed is 15-17m/s, but the rotor is slightly out of the wind to reduce the wind power below the available load. Extra 100kVAr capacitors during startup ensure that nominal voltage is obtained before nominal frequency is reached. Control routine is faster and capacitor steps have been reduced to 5kVAr. In time period 30-60 seconds the load varies between 80-110kW and then decreases, which indicate decreasing wind. Variation in frequency and voltage is well within acceptable limits and compares to official grid quality.

VI. REFERENCES

- [1] W. M. Sommeville, "Operating experience of the Fair Isle wind turbine" *IEE PROCEEDINGS*, vol. 134, Pt. A, No. 5, May 1987.
- [2] G. K. Singh, "Self-Excited Induction Generator Research - A Survey", *Electric Power Systems Research*, vol. 69, no.2-3, pp. 107-114, May 2004.
- [3] R. C. Bansal, "Three phase self excited induction generators: an overview," *IEEE Trans. Energy Conversion*, vol. 20, pp. 292 – 299, June 2005.
- [4] M. Basic, D. Vukadinovic and D. Lukac, "Novel dynamic model of self-excited induction generator with iron lossess". *International journal of mathematical models and methods in applied sciences*, Issue 2, Volume 5, 2011.
- [5] D. Seyoum, "The Dynamic Analysis and Control of a Self-Excited Induction Generator Driven by a Wind Turbine", Ph. D. thesis, School of Electrical Engineering and Telecommunications, UNSW, Sydney, Australia, 2003.
- [6] D. Seyoum, C. Grantham and F. Rahman. "Analysis of an isolated self-excited induction generator driven by a variable speed prime mover" Available 30 June 2013: http://itee.uq.edu.au/~aupec/aupec01/063_SEYOUM_AUPEC01paper%20revised.pdf
- [7] M. A. Elsharkawi, S. S. Venkata, T. J. Williams, and N. G. Butlar, "An adaptive power factor controller for three-phase induction generators," *IEEE Trans. Power App. Syst.*, vol. PAS-104, no. 7, pp. 1825–1831, Jul. 1985.
- [8] E. Suarez and G. Bortolotto. "Voltage-frequency control of a self-excited induction generator", *IEEE Transactions on Energy Conversion*, vol.14, no.3, pp.394,401, Sep 1999
- [9] G. V. Jayaramaiah and B. G. Fernandes, "Novel voltage controller for stand-alone induction generator using PWM-VSP". *Industry Application Conference, 2006. 41st IAS Annual Meeting.*
- [10] D. Joshi, K. S. Sandhu, M. K. Soni. "Constant voltage constant frequency operation for a self-excited induction generator," *IEEE Transactions on Energy Conversion*, vol.21, no.1, pp.228-234, March 2006
- [11] J. M. Ramirez and E. M. Torres. "An electronic load controller for self-excited induction generators" *Power Engineering Society General Meeting, 2007. IEEE*
- [12] R. Ahshan and M. T. Iqbal, "Voltage controller of a single phase self-excited induction generator". *The Open Renewable Energy Journal*, 2009, 2, 84-90.
- [13] S. A. Deraz and F. E. Abdel Kader, "A new control strategy for a stand-alone self-excited induction generator driven by a variable speed wind turbine". *Renewable Energy*, Volume 51, March 2013, pp 263–273.
- [14] D. Vukadinovic and M. Basic, "A stand-alone induction generator with improved stator flux oriented control". *J. of Electrical Engineering*, vol. 62, No. 2, 2011, 65-72
- [15] M. Jain, S. Gupta and G. Agnihotri. "Design of voltage controller for parallel operated self excited induction generator — Micro grid," *International Conference on Energy, Automation, and Signal (ICEAS)*, pp.1-6, 28-30 Dec. 2011
- [16] S. S. Singh and A. N. Tiwari. "Voltage and frequency controller for self excited induction generator in micro hydro power plant: Review". *IJARECE* vol.2, iss. 2, February 2013.
- [17] G. Vijayakumar, "A novel control strategy for a stand-alone SEIG in renewable energy system". *Int. J. of Adv. Comp. Eng. and Networking*, ISSN: 2320-2106, Volume – 1, Issue – 1, 2013
- [18] S. Gaoe, G. Bhuvaneswari, S. S. Murthy and U. Kalla. "Efficient voltage regulation scheme for three-phase self-excited induction generator feeding single-phase load in remote locations". *IET Renew. Power Gener.*, 2014, Vol. 8, Iss. 2, pp. 100-108.
- [19] L. Wang and D.-J. Lee, "Coordination Control of an AC-to-DC Converter and a Switched Excitation Capacitor Bank for an Autonomous Self-Excited Induction Generators in Renewable-Energy Systems," *IEEE Transactions on Industry Applications*, Iss. 99, 2014.
- [20] <http://playground.arduino.cc/Code/PIDLibrary> (accessed 11/3-2014)

VII. BIOGRAPHIES



Bjarti Thomsen was born in Klaksvík, Faroe Islands, in 1955. He received his MScEng from Aalborg University 1990, an MBA from Robert Gordon University, Aberdeen, UK in 2000 and an MScHE (offshore industry) from the University of Aberdeen, UK in 2001.

He was a scientist at the Marine Laboratory in the Faroe Islands from 1990-1997 specialized in fish behavior and fishing gear technology and head of administration at the institute until 2001.

From 2003 to 2011 he was Research Manager in Fisheries Technology at the Faroese Fisheries Ministry with emphasis on energy efficiency and reduced environmental impact. From 2006 he has been project developer for the wind-heating energy project at Nólsoy, Faroe Islands. In 2012 he joined the Faroese Earth and Energy Directorate as an Engineer and Renewable Energy Advisor.



Josep M. Guerrero (S'01-M'04-SM'08) was born in Barcelona, Spain, in 1973. He received the B.S. degree in telecommunications engineering, the M.S. degree in electronics engineering, and the Ph.D. degree in power electronics all from the Technical University of Catalonia, Barcelona, Spain, in 1997, 2000, and 2003, respectively.

He was an Associate Professor with the Department of Automatic Control Systems and

Computer Engineering, Technical University of Catalonia, where he currently teaches courses on digital signal processing, field-programmable gate arrays, microprocessors, and renewable energy. Since 2004, he has been responsible for the Renewable Energy Laboratory, Escola Industrial de Barcelona. He has been a visiting Professor at Zhejiang University, Hangzhou, China, and the University of Cergy-Pontoise, Pontoise, France. In 2012, he was the Guest Professor Chair at Nanjing University Aeronautics and Astronautics. Since 2011, he has been a Full Professor of microgrids at the Institute of Energy Technology, Aalborg University, Aalborg, Denmark, where he is the responsible of the microgrids research program. His research interests are oriented to different Microgrids aspects, including power electronics, distributed energy storage systems, hierarchical and cooperative control and energy management systems, and optimization of microgrids and islanded minigrids.

Dr. Guerrero is an Associate Editor for the IEEE TRANSACTIONS ON POWER ELECTRONICS, the IEEE TRANSACTIONS ON INDUSTRIAL ELECTRONICS, and the IEEE Industrial Electronics Magazine. He has been the Guest Editor of the IEEE TRANSACTIONS ON POWER ELECTRONICS Special Issues: Power Electronics for Wind Energy Conversion and Power Electronics for Microgrids; and the IEEE TRANSACTIONS ON INDUSTRIAL ELECTRONICS Special Sections: Uninterruptible Power Supplies systems, Renewable Energy Systems, Distributed Generation and Microgrids, and Industrial Applications and Implementation Issues of the Kalman Filter. He currently chairs the Renewable Energy Systems Technical Committee of the IEEE Industrial Electronics Society.



Paul B. Thøgersen (M'92-SM'01) was born in Thy, Denmark, on June 29, 1959. He received the M.Sc.E.E. degree in control engineering and the Ph.D. degree in power electronics and drives from Aalborg University, Aalborg, Denmark, in 1984 and 1989, respectively.

From 1988 to 1991, he was an Assistant Professor with Aalborg University. From 1991 to 2005, he was with Danfoss Drives A/S, Graasten, Denmark, where he was, first, a Research and

Development Engineer and, later, Manager of Technology, mainly responsible for the drives control technology area. Since 2006, he has been the Manager of the Modeling and Control Group, which is a part of the R&D Department, KK-Electronic A/S, Herning, Denmark. Since 1991, he has had a close relationship with Aalborg University, resulting in more than 20 coauthored papers and participation in more than ten Ph.D. student advisory groups.

Dr. Thøgersen was the recipient of the Angelos Award in 1999 for his contributions to the development of industrial drives.