



AALBORG UNIVERSITY
DENMARK

Aalborg Universitet

Auxillary Fluid Flowmeter

RezaNejad Gatabi, Javad; Forouzbakhsh, Farshid; Ebrahimi Darkhaneh, Hadi; RezaNejad Gatabi, Zahra; Janipour, Majid; RezaNejad Gatabi, Iman

Published in:
European Journal of Scientific Research

Publication date:
2010

Document Version
Early version, also known as pre-print

[Link to publication from Aalborg University](#)

Citation for published version (APA):
RezaNejad Gatabi, J., Forouzbakhsh, F., Ebrahimi Darkhaneh, H., RezaNejad Gatabi, Z., Janipour, M., & RezaNejad Gatabi, I. (2010). Auxillary Fluid Flowmeter. European Journal of Scientific Research, 42(1), 84-92.

General rights

Copyright and moral rights for the publications made accessible in the public portal are retained by the authors and/or other copyright owners and it is a condition of accessing publications that users recognise and abide by the legal requirements associated with these rights.

- ? Users may download and print one copy of any publication from the public portal for the purpose of private study or research.
- ? You may not further distribute the material or use it for any profit-making activity or commercial gain
- ? You may freely distribute the URL identifying the publication in the public portal ?

Take down policy

If you believe that this document breaches copyright please contact us at vbn@aub.aau.dk providing details, and we will remove access to the work immediately and investigate your claim.

Auxiliary Fluid Flowmeter

Javad Rezanejad Gatabi

*Electrical Engineering Department, Iran University of Science and Technology
Narmak, Tehran, Iran*

E-mail: javad_rezanejad_gatabi@yahoo.com
Tel: +98-21-77724583; Fax: +98-21-77724459

Farshid Forouzbakhsh

*Electrical Engineering Department, Faculty of Engineering
University of Tehran, Tehran, Iran*

E-mail: fforouz@ut.ac.ir
Tel: +98-912-1060287; fax: +98-21-66493113

Hadi Ebrahimi Darkhaneh

*Electrical Engineering Department, Iran University of Science and Technology
Narmak, Tehran, Iran*

E-mail: hebrahimi1985@gmail.com
Tel: +98-21-81713448; Fax: +98-21-88640930

Zahra Rezanejad Gatabi

Department of Pharmacy, Mazandaran University of Medical Sciences, Sari, Iran

E-mail: z.rezanejad@yahoo.com
Tel: +98-21-77724583; Fax: +98-21-77724459

Majid Janipour

*Mechanical Engineering Dept., Iran University of Science and Technology
Narmak, Tehran, Iran*

E-mail: m.c.janipour@gmail.com
Tel: +98-21-77724583; Fax: +98-21-77724459

Iman Rezanejad Gatabi

*Electrical Engineering Department, K. N. T. University of Technology
S. Khandan, Tehran, Iran*

E-mail: alisaeeidiv@yahoo.com
Tel: +98-21-77724583; Fax: +98-21-77724459

Abstract

The Auxiliary Fluid Flowmeter is proposed to measure the fluid flow of any kind in both pipes and open channels. In this kind of flow measurement, the flow of an auxiliary fluid is measured Instead of direct measurement of the main fluid flow. The auxiliary fluid is injected into the main fluid and with measuring its travel time between two different positions, its velocity could be calculated. Given the velocity of the auxiliary fluid, the velocity of the main fluid could be calculated. Using this technique, it is possible to

measure the velocity of any kind of fluids, if an appropriate auxiliary fluid be choosed. The fabrication of a prototype flowmeter and experimental verification of the analytical data were reported. The fabricated prototype is able to measure the velocity of the water in an open channel.

Keywords: Flowmeter, main fluid, Auxiliary Fluid, injection, open channel Flowmeter, Electrolytical conductivity

1. Introduction

Measuring the velocity and flow rate of flowing fluids is important in both research and industry purposes. Nowadays, various kinds of flowmeters such as: Ultrasonic [1, 2] and Turbine flowmeters [3] and Electromagnetic flow measurements [4] are widely used. For all of these systems, the situations and standards are important. Hence, a flowmeter designer will be limited to use some sensors and certain equipments in his/her design. So the process of production will be expensive and in some applications, designing a flowmeter for a certain fluid, using the current method would be expensive.

In this paper we have proposed a method in which an auxiliary fluid could be used to measure the flow of the main fluid. The auxiliary fluid is injected into the main fluid and its velocity is measured. Given the velocity of the auxiliary fluid, the flow rate of the main fluid could be calculated. By means of an appropriate auxiliary fluid, it is possible to add new features to the flowmeter system. For instance, a simple sensor could be selected for the flowmeter and it is either possible to measure the velocity of fluids of any kind. With this technique, flowmeters for certain materials or situations could be designed e.g. no matter the fluid has more impurity and bubbles.

2. Principle of Operation

Fig.1 illustrates the configuration of the proposed Auxiliary Fluid Flowmeter. As the figure shows, the main fluid is flowed together with the auxiliary fluid (AF) into the pipe. There are two sensors in the pipe positioned at a certain distance of X from each other which are sensitive to the auxiliary fluid. In presence of the auxiliary fluid, a change occurs in an electrical property of the sensor (e.g. Change in electrical resistance, inductance or capacitance).

Figure 1: The Configuration of the Auxiliary Fluid Flowmeter.

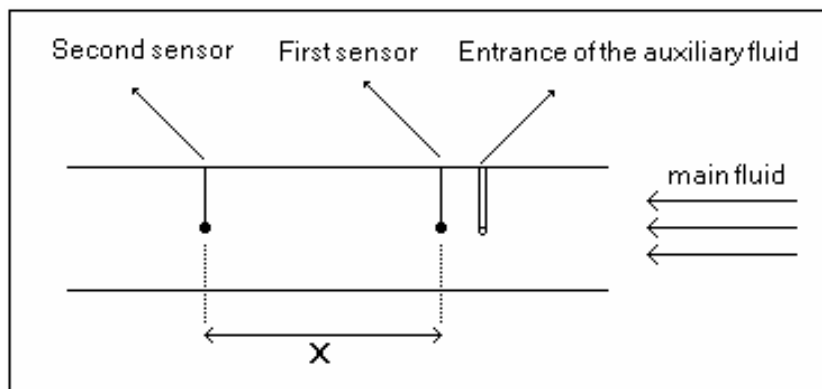

When the AF reaches the first sensor at the time $t=t_1$, an electric pulse will be provided by this sensor as illustrated in Fig.2.a. Then the AF flows together with the main fluid toward the second sensor and therefore an electric pulse will be created on the output of the second sensor at time $t=t_2$ as shown in Fig.2.b.

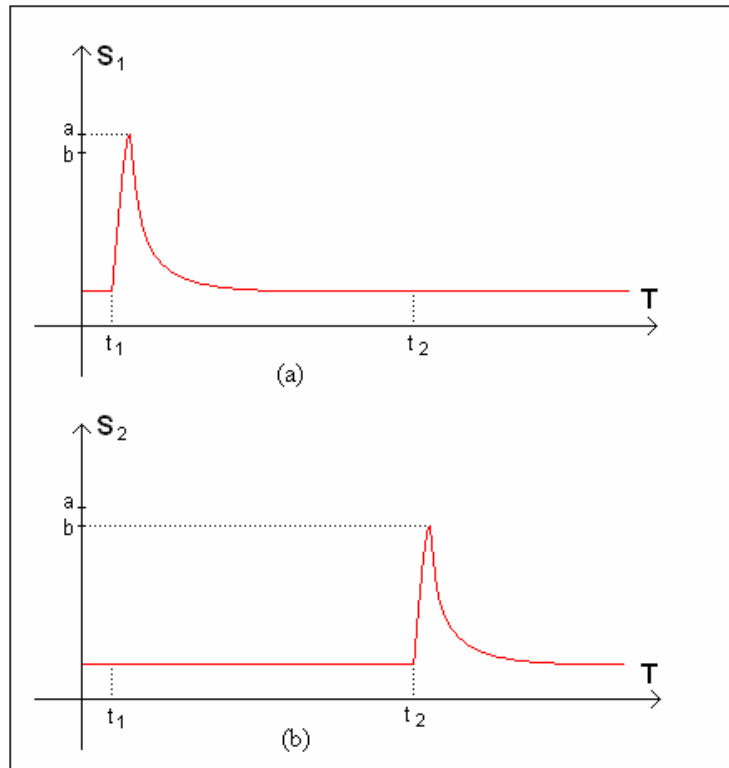
Figure 2: (a) The output pulse of the first sensor (b) The output pulse of the second sensor.

At first, the output of each sensor is constant. In the presence of AF, the sensor output signal would rise to a certain value instantaneously. Then it will decrease slowly along the time, due to the time needed for a volume of AF to pass the sensor. It is desirable to decrease this fall time by decreasing the volume of injected AF. But certain amount of AF is needed to meet the minimum requirement set by the sensitivity of the sensor. Because the AF is propagated as it moves forward in the pipe, the second sensor meets less concentration of it and therefore the peak values of output signals of the first and second sensors (a and b) are different.

Measuring the time between two pulses (T) helps us to calculate the mean velocity of the AF in the pipe using:

$$V_{A.F.} = X/T$$

Calculating the $V_{A.F.}$ relates to measurement of the flow rate of the main fluid considering the fluids behaviors, flow velocity profile and other effective parameters.

In open channel and also close conduit systems, It's clear that:

$$V_{A.F.} \neq V_{M.F.}$$

Where, $V_{M.F.}$ is the mean velocity of the main fluid. Hence, reaching the flow rate amount from $V_{A.F.}$ requires several equations to be solved. We experimentally proved that: in turbulent flows by implementation of some changes in system and factors we can ignore the error sources and have:

$$V_{A.F.} \approx V_{M.F.}$$

Given the area of the pipe, the flow rate could be calculated.

These important factors mentioned below:

- Blockade made by sensors which are placed in the fluid flow direction would change the velocity of the fluid inside the pipe and makes a large amount of error in measuring.

To obtain this problem, choosing sensors with smaller dimensions related to the diameter of the pipe would be helpful because smaller sensors do not change the profile of the flow. On the other hand using non-contact sensors is ideal.

- The volume of the AF and its injection velocity is so important in accurate measurements. Injection of the AF inside the main fluid would cause the velocity of the main fluid changes and becomes far from its actual value.

The amount of injected auxiliary fluid should be decreased as much as possible and at the same time, the sensitivity of each sensor should be increased.

- Density Difference between AF and main fluid causes different velocity between them. To overcome this problem the AF density should be close to the main fluid density.

It is necessary to choose an appropriate AF, one which could stimulate the sensor well. In order to increase the accuracy of the device, it is possible to implement more than two sensors. In this manner, the velocity of the flow is measured for several distances between the sensors and therefore a more precise measurement will be achieved.

The AF may affect the sensor in several ways. The sensors might be sensitive to the color or electrolytical conductivity of the AF, or it is possible that the inductance or capacitance of the sensor to be changed in presence of AF.

- **Color based sensors-** In this kind of sensors, the opacity of the auxiliary fluid against visible light, ultraviolet or laser beams should be different from that of the main fluid. The sensor could determine the AF from the intensity of received beam.
- **Inductance or capacitance based sensors-** In this kind of sensors, the AF behaves as the core of a coil (in inductance based sensors) or it plays the role of a dielectric of a capacitor (in capacitance based sensors). Based on the type of the sensor, its inductance or capacitance is changed in presence of AF.
- **Electrolytical conductivity (EC) based sensors-** An auxiliary fluid which has a different EC comparing to the main fluid must be used and sensors are composed of two metal bars put inside the main fluid and the resistance between two bars is measured. The resistance would change in the presence of auxiliary fluid and this helps the signal to determine AF.

3. Experimental Results

The fabricated prototype A. F. Flowmeter is a water flowmeter which measures the velocity of flowing water in open channels. The device is able to measure fluid rates in the range of 0.3 m/s – 5 m/s with a precision of 1%. This prototype consists of a cylindrical stainless steel pipe with external diameter of 104 millimeter and internal diameter of 100 millimeter and a length of 60 centimeter. Achieving to an accuracy of 1% in this water flowmeter is possible with using two sensors positioned 0.5 meter distant from each other.

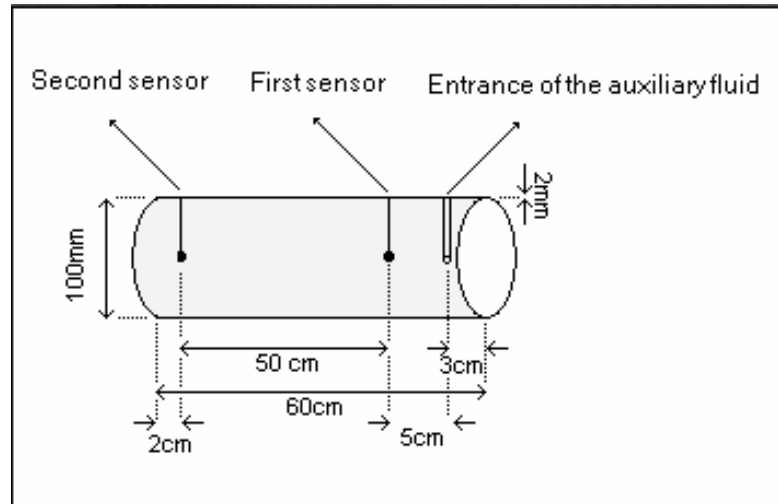
Figure 3: The diagram of the fabricated prototype.

In order to measure the flow of the water, saltwater was selected as the auxiliary fluid. Because many physical and chemical properties of the saltwater are similar to that of the water and the saltwater does not make non-standard impurity in water, it operates as an appropriate AF. The implemented sensors measure the electrolytical conductivity of the fluid and hence it measures a different value in the presence of the saltwater.

The device has an electro pump that injects a volume of 1 CC saltwater per second in the flowmeter. So by activating the pump for 0.2 seconds, it is possible to inject 0.2 CC saltwater in the flowmeter which is sufficient to be sensed with the sensors.

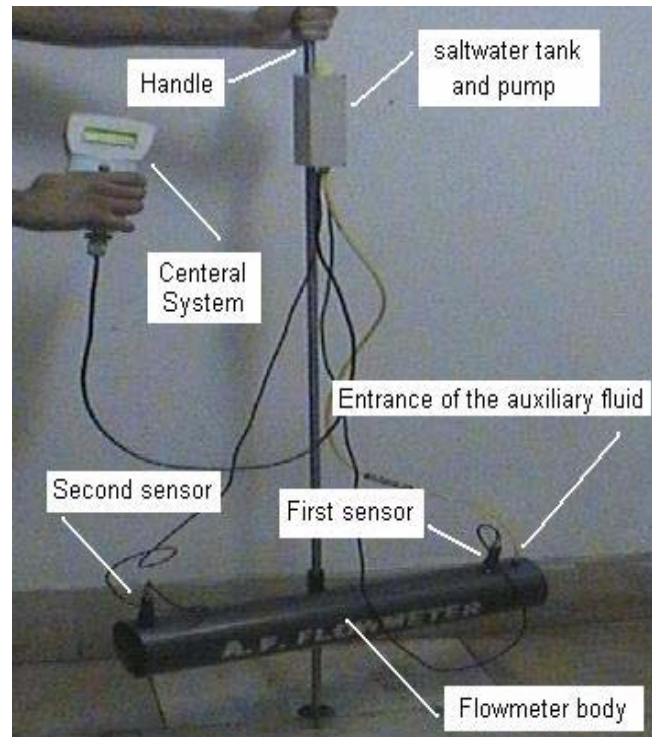
Figure 4: The picture of the fabricated prototype.

The sensors consist of two metal blades with a dimension of 30 mm * 2 mm * 0.2 mm placed at a distance of 2 mm from each other.

Figure 5: The diagram of the E.C. sensors.

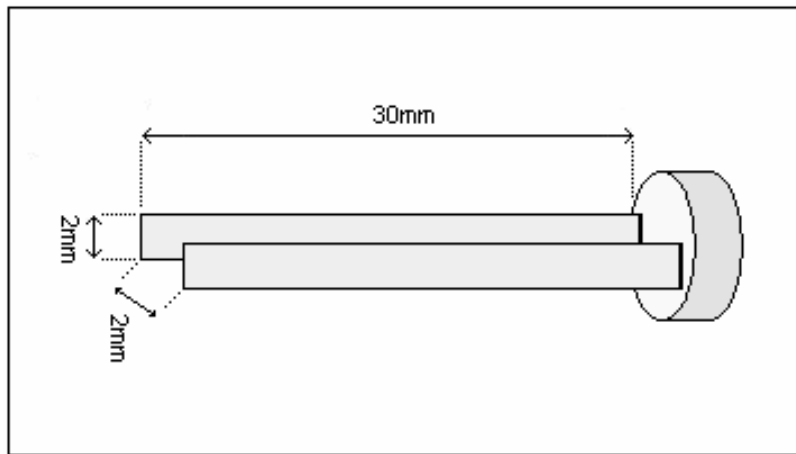

What is important to measure is the variation of the electrical conductivity not EC itself. Therefore it is not required to have very precise sensors.

For a two-electrode electrochemical cell, electrolytical conductivity κ is given by:

$$\kappa = \frac{L}{A} \cdot G$$

Where G is the Ohmic conductance of solution, L is the distance between two electrodes and A is the electrode surface.

By means of an appropriate excitation signal and electrodes and etc. it's proved that: [9, 10, 11]

$$K = i_{ac} / v_{ac}$$

In order to measure the transit-time of the Auxiliary Fluid between two sensors and also to other calculations, a microcontroller was implemented.

If the distance between two sensors be X and the time required for AF to travel from the first sensor to the second one be T , therefore the velocity of the Auxiliary Fluid, V'_m could be calculated through the following formula:

$$V'_m = X / T$$

Therefore measurement of T allows the velocity of the auxiliary fluid to be calculated. But the velocity of the AF does not equal to the velocity of the main fluid at the center of the pipe, V_m . This difference is due to the initial velocity of AF when it is injected into the main fluid and also the volume of injected AF. The following figure illustrates the experimentally aided trace of the V_m versus V'_m obtained through the calibration of the prototype.

Figure 6: Relationship between saltwater and water mean velocity in the center of the pipe. (Saltwater volume = 0.2 cc)

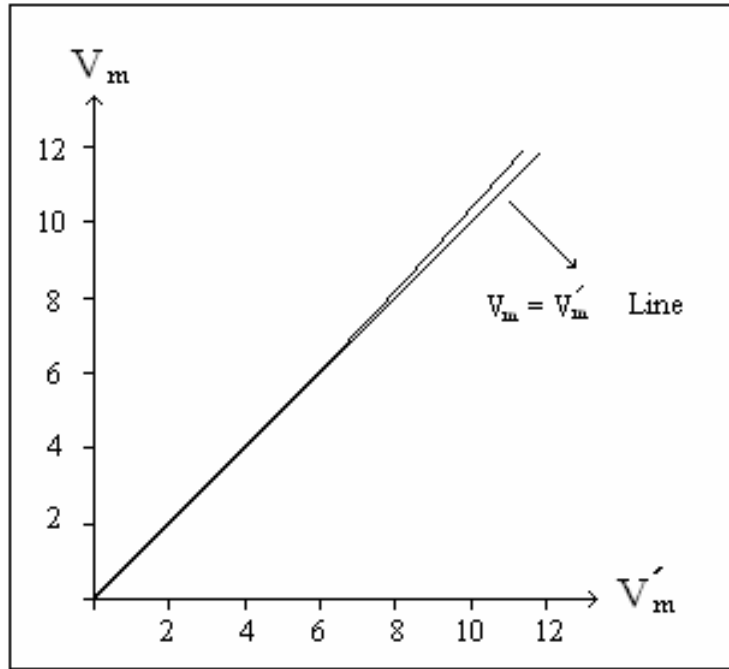

For sufficiently great values of V_m , the difference between V_m and V'_m becomes great. This is because of the difference between the initial velocity of the saltwater and the water itself. To reduce this difference, it is possible to decrease the volume of the injected AF, but certain minimum amount of AF is required to be sensed by the sensors. For smaller values of V_m (lower than 7 m/s), these curves are approximately co-inside with each other.

- After calculating the water's mean velocity at the center of the pipe, it is necessary to calculate the channel velocity. The relationship between V_m and V depends on some factors such as: fluid material's properties and the dimensions of the flowmeter. If the ratio between the pipe's diameter and its length be appropriate, then it is possible to have a linear relationship between V_m and V . Following trace shows the error of the fabricated prototype in various fluid velocities obtained from the calibration of the device.

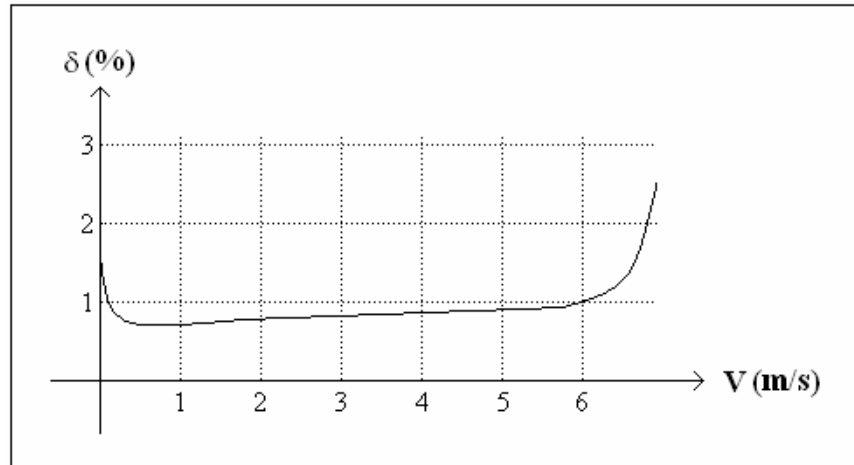
Figure 7: Measured error in various fluid velocities.

- For fluid velocities smaller than 0.3 m/s, the propagation of the AF in the main fluid and its solution in it are the main reasons of increasing the error in this interval. For fluid velocities greater than 6 m/s, the limitations of sampling times of the sensors, eddy, circular or turbulent flow formation are among the main results to increase the measurement error.

The temperature variation effect on the flow measurement in our proposed flowmeter is illustrated in the following trace. Compared with other kinds of flowmeters, the A.F. Flowmeter has a lower influence from the temperature variation.

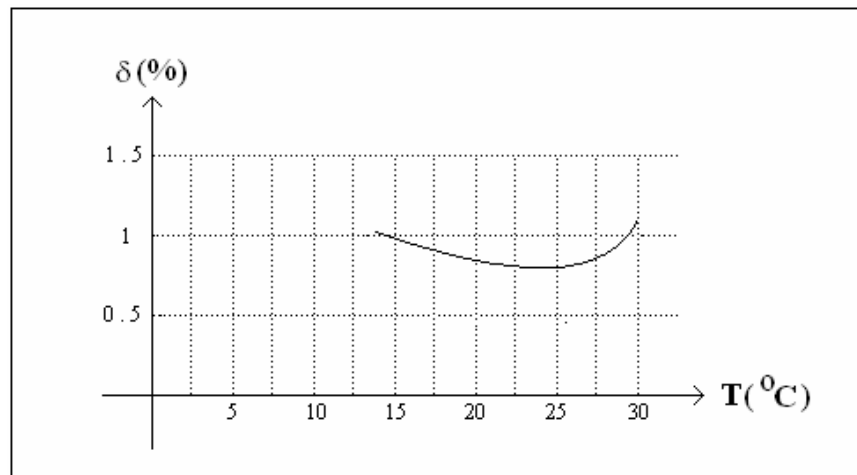
Figure 8: The measurement error of the A.F. Flowmeter versus the temperature ($V= 2.5$ m/s)

Conclusions

In this paper, we have introduced a new kind of flowmeter named the Auxiliary Fluid Flowmeter. The proposed method is less affected when temperature changes compared to other flow measurements. It is also possible to implement the A.F. Flowmeter when the fluid has some kinds of external impurities or bubbles. The fabricated prototype is able to measure the velocity of the flowing water in an open channel.

Acknowledgement

This project was fulfilled as a research project supported by “Mazandaran State Water Organization”
The authors wish to acknowledge the following people for their helpful discussions and encouragement:

Prof. A. Araghi, Noshirwani Industrial University of Babol.

Prof. Raazeghi, Iran University of Science and Technology.

Mr. A. Yadollahinia, Mr. M. Taghipour, Mr. M. Soltani, Mr. I. Yousefi, Mr. M. Masumi, Mr. T. Mohammadi, Mr. F. Tabandeh, Iran University of Science and Technology.

Mr. A. Firouzi, Mr. E. Khataei, Mr. A. Nowrozian, Gatab Electronics Co. Ltd.

References

- [1] L.C. Lynnworth and Yi Liu, “Ultrasonic flowmeters: Half-century progress report, 1955–2005”, *Ultrasonics* 44 (2006) e1371–e1378
- [2] J. M. Szebeszczyk, “Application of clamp-on ultrasonic flowmeter for industrial flow measurements”, *Flow Measurement and Instrumentation*, Volume 5, Issue 2, April 1994, Pages 127-131
- [3] L.M. López-González, J.M. Sala, J.A. González Bustamante, J.L. Míguez, “Modelling and simulation of the dynamic performance of a natural-gas turbine flowmeter”, *Applied Energy*, Volume 83, Issue 11, November 2006, Pages 1222-1234
- [4] Paul D. Stein, “Velocity and flow measurements by electromagnetic techniques”, *The American Journal of Cardiology*, Volume 29, Issue 3, March 1972, Pages 401-407
- [5] F. Hernández¹, J. Morales¹, M. Navarrete² and M. Villagrán-Muniz³, “Determination of velocity profiles in pipes by a pulsed photoacoustic method”, *J. Phys. IV France* 125 (2005) 339-341 DOI: 10.1051/jp4:2005125080.
- [6] M. Willatzen, “Temperature gradients and flow-meter performance”, *Ultrasonics*, Volume 39, Issue 5, August 2001, Pages 383-389
- [7] G. W. Ewing, “Instrumental Methods of Chemical Analysis”, McGraw-Hill College, 1995.
- [8] J. Braunstein, G.D. Robbins, “Electrolytic conductance measurements and capacitive balance”, *Journal of Chemical Education* 48 (1) (1981) 52–59.
- [9] Diego Ramírez Muñoz *, Silvia Casans Berga, An analog electronic interface to measure electrical conductivity in liquids, *Measurement* 38 (2005) 181–187.
- [10] E. Ferrara, L. Callegaro, F. Durbiano, Optimal frequency range for the measurement of AC conductivity in aqueous solutions, in: 17th IEEE Instrumentation and Measurement Technology Conference, Baltimore, May, 2000.
- [11] J. Braunstein, G.D. Robbins, Electrolytic conductance measurements and capacitive balance, *Journal of Chemical Education* 48 (1) (1981) 52–59.