



Aalborg Universitet

AALBORG UNIVERSITY  
DENMARK

## Joint efforts to harmonize sound insulation descriptors and classification schemes in Europe (COST TU0901)

Rasmussen, Birgit

*Published in:*  
Proceedings of Euroregio 2010, Congress on Sound and Vibration

*Publication date:*  
2010

*Document Version*  
Publisher's PDF, also known as Version of record

[Link to publication from Aalborg University](#)

*Citation for published version (APA):*

Rasmussen, B. (2010). Joint efforts to harmonize sound insulation descriptors and classification schemes in Europe (COST TU0901). In *Proceedings of Euroregio 2010, Congress on Sound and Vibration*

### General rights

Copyright and moral rights for the publications made accessible in the public portal are retained by the authors and/or other copyright owners and it is a condition of accessing publications that users recognise and abide by the legal requirements associated with these rights.

- ? Users may download and print one copy of any publication from the public portal for the purpose of private study or research.
- ? You may not further distribute the material or use it for any profit-making activity or commercial gain
- ? You may freely distribute the URL identifying the publication in the public portal ?

### Take down policy

If you believe that this document breaches copyright please contact us at [vbn@aub.aau.dk](mailto:vbn@aub.aau.dk) providing details, and we will remove access to the work immediately and investigate your claim.

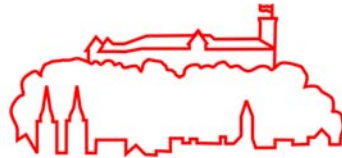

**1<sup>st</sup> EAA – EuroRegio 2010**

**Congress on Sound and Vibration**

**15 - 18 September 2010, Ljubljana, Slovenia**

**With Summer School for Young Researchers from 13 - 15 September 2010**

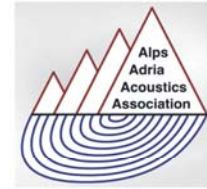

## **Joint efforts to harmonize sound insulation descriptors and classification schemes in Europe (COST TU0901)**

Birgit RASMUSSEN

SBi, Danish Building Research Institute, Aalborg University,  
Dr. Neergaards Vej 15, DK-2970 Hørsholm, DENMARK, e-mail: bir@sbi.dk

### **ABSTRACT**

Sound insulation descriptors, regulatory requirements and classification schemes in Europe represent a high degree of diversity. One implication is very little exchange of experience of housing design and construction details for different levels of sound insulation; another is trade barriers for building systems and products. Unfortunately, there is evidence for a development in the "wrong" direction. For example, sound classification schemes for dwellings exist in nine countries. There is no sign on increasing harmonization, rather the contrary, as more countries are preparing proposals with new classes.

Social surveys in several European countries have shown that occupants of multi-storey housing are considerably annoyed by noise from neighbours' activities. To keep towns and cities attractive, homes in multi-storey housing must be attractive for a variety of people and offer "quietness". Thus, new housing must meet the needs of the people and offer comfort. Also for existing housing, sound insulation aspects should be taken into account, when renovating housing; otherwise the renovation is not "sustainable".

A joint European Action, COST TU0901 "Integrating and Harmonizing Sound Insulation Aspects in Sustainable Urban Housing Constructions", has been approved and runs 2009-2013. The main objectives are to prepare proposals for harmonized sound insulation descriptors and for a European sound classification scheme. Other goals are e.g. to establish a catalogue of sound insulation data and an on-line compendium on good workmanship.

The paper will summarize the background, discuss the present situation in Europe and describe the joint efforts to reduce the diversity in Europe.

## 1. BACKGROUND AND INTRODUCTION

Social surveys in several European countries have shown that occupants of multi-storey housing are considerably annoyed by noise from neighbours' activities. The World Health Organisation (WHO) defines health as “a state of complete physical, mental and social well-being and not merely the absence of disease or infirmity”, cf. [1]. Based on this definition, noise effects on health should not simply be understood as the adverse physical effects due to noise exposure, but also as disturbance of well-being, i.e. psychological effects of noise, which in the long term may lead to adverse physical effects. WHO has identified a considerable number of specific adverse health effects caused by environmental noise, cf. [2]. These effects can be medical conditions, but can also include sleep disturbance, stress etc.

The relevance of the sound insulation issue is illustrated in Figure 1 (ref. [3]) showing the amount of serious noise annoyance in national surveys in three EU countries, representing about 1/3 of the total EU population. In spite of uncertainties due to different methodologies (including questionnaires) applied for the surveys, the author of [3] concluded that the neighbour noise problem in Europe is significant. In [4], results from different social surveys are included, and the shortcomings due to inconsistent questionnaires in different countries are described. Neighbour noise has been addressed in a large pan-European LARES study (Large Analysis and Review of European housing and health Status) coordinated by WHO/Europe. The WHO LARES study included eight European cities and the purpose was to evaluate the health impact of housing conditions. Results are found at the WHO website [2] (some quotes and more detailed references are found in [6] and [16]).

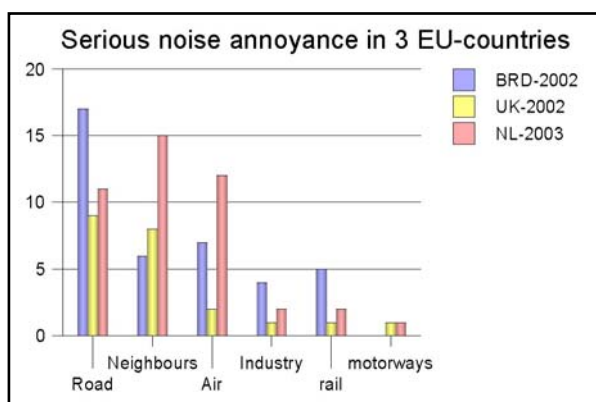

**Figure 1.** Sources of serious noise annoyance (% of inhabitants) in three EU countries. Ref: Martin van den Berg, 2004, [3].

When ranking annoyance from different noise sources, road traffic noise is the most dominant source, followed by neighbour noise. Based on statistics about populations [5] and findings from noise annoyance surveys (see eg Figure 1 or [4]), it seems that more than 50 million Europeans are exposed to neighbour noise causing adverse effects on quality of life.

To keep towns and cities attractive, homes in multi-storey housing must be attractive for a variety of people and offer “quietness”. Thus, new housing must meet the needs of the people and offer comfort. Also for existing housing, sound insulation aspects should be taken into account, especially when renovating housing. The challenge is huge, and knowledge exchange between countries is highly needed. Comparative studies of sound insulation descriptors and regulatory requirements in Europe are described in [6-7] and sound classification schemes described in [8-9]. However, a high degree of diversity is found for descriptors, level of requirements and classification schemes in Europe, thus impeding exchange of experience of housing design and construction details for different levels of sound insulation. The need for harmonization is emphasized in [6-7] and several research initiatives suggested.

The situation in Europe is summarized in Section 2 for sound insulation descriptors and regulatory requirements. An overview of classification schemes is found in Section 3. The harmonization efforts through COST Action TU0901, [10], are described in Section 4. This paper – like COST TU0901 – focuses on neighbour noise and sound insulation between dwellings.

## 2. SOUND INSULATION DESCRIPTORS AND REQUIREMENTS IN EUROPE

Building acoustic requirements for dwellings now exist in more than 30 countries in Europe. In some countries, national sound insulation requirements have existed since the 1950s. Comparative studies of descriptors and regulatory sound insulation requirements in 24 countries in Europe are described in [6-7]. The comparison reveals significant discrepancies in descriptors and requirements for dwellings. For both airborne and impact sound insulation requirements, several descriptors are applied in Europe. Examples of descriptors applied:

- Airborne sound insulation, e.g.:  $R'_w$ ;  $R'_w + C$ ;  $R'_w + C_{50-3150}$ ;  $D_{nT,w}$ ;  $D_{nT,w} + C$
- Impact sound pressure level, e.g.:  $L'_{n,w}$ ;  $L'_{n,w} + C_{I,50-2500}$ ;  $L'_{nT,w}$ ;  $L'_{nT,w} + C_I$
- Besides, there are variants; recommendations and special rules

The most recent version of the standard EN ISO 717 [11] has contributed to the diversity in Europe by allowing many different descriptors and by introducing spectrum adaptation terms with different extended frequency ranges. A detailed overview of standardized sound insulation field descriptors is found in [6] (Table 1), including applications in Europe.

The main requirements on airborne and impact sound insulation are presented in Figure 2 and 3. In order to facilitate a comparison between countries, all requirements (cf. [6], Tables 2 and 3), have been converted into estimated equivalent values of  $R'_w$  and  $L'_{n,w}$  based on assumptions about rooms and construction types. In case of the equivalent  $R'_w$  being an interval, the average value has been indicated. The equivalent values are estimates only, as exact conversion is not possible. The results in Figures 2 and 3 show big differences between countries, especially for impact sound insulation requirements with max differences of equivalent  $L'_{n,w}$  limits more than 15 dB for multi-storey housing. For more detailed findings, see [6-7].

When digging deeper into the building codes and related documents, hidden special rules and/or conditions are often revealed. For example, cf. [12], the Swiss standard SIA 181:2006 with sound insulation requirements has become very complex to apply due to several nuisance levels and receiver sensitivity levels. Furthermore, national methods, procedures and correction terms have been defined. The symbol table is 11 pages! As another example could be mentioned special rules in the Nordic countries, see [13-14]. Even in case of seemingly identical limits, sometimes they are different due to special rules, eg volume limitations.

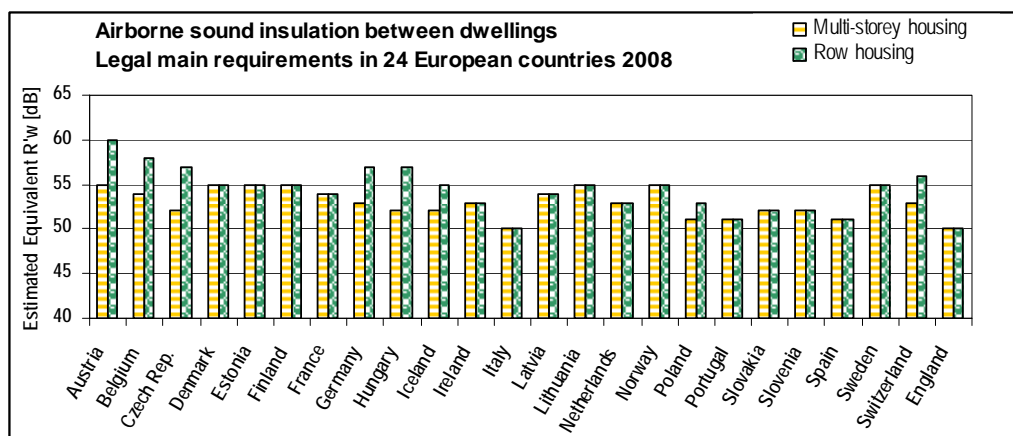

**Figure 2.** Overview of airborne sound insulation requirements between dwellings. Graphical presentation of estimated equivalent values of  $R'_w$ .

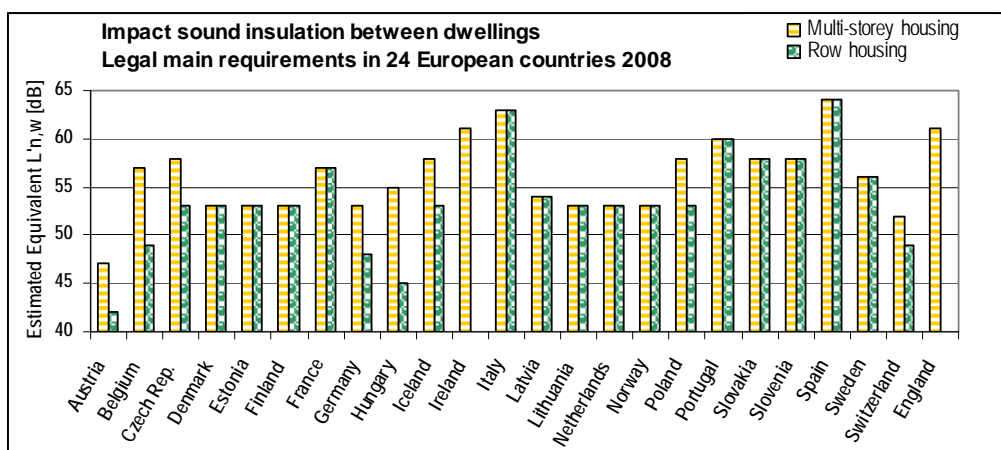
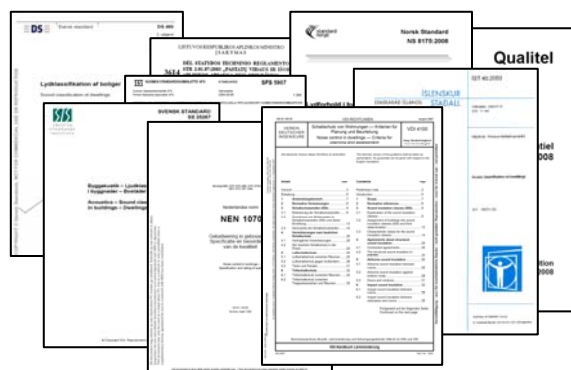

**Figure 3.** Overview of impact sound insulation requirements between dwellings. Graphical presentation of estimated equivalent values of  $L'_{n,w}$ .

Concerning regulations, a big challenge seems to be that for some types of light-weight constructions, the subjective sound insulation is ranked lower than for a heavy construction with the same objective sound insulation. Regulatory requirements are objective, and the same requirements should be applicable for all types of housing constructions and materials. Thus, an important research task is to develop new objective descriptors (evaluation methods) correlating with the subjective evaluation for all types of constructions. – In Norway, a survey [15] about satisfaction with newly built homes (2005) has been carried out in 2007. In general, people are satisfied (about 80%, 10% dissatisfied). Least satisfaction (17% dissatisfied) is found with sound insulation, especially for 2-storey housing (27% dissatisfied). According to [16], the reason is likely to be light-weight constructions applied for this type of housing.

### 3. SOUND CLASSIFICATION SCHEMES IN EUROPE

Sound classification schemes describe different quality classes to meet different needs of activities and quietness in the home. Classification schemes exist at present in 9 countries in Europe. The first classification schemes for dwellings were implemented in the early 1990s (France and Germany). Sound classification schemes in Europe are national schemes, the majority being published by national standardization organizations, see Figure 4. An overview of existing sound classification schemes for dwellings is found in Table 1. For each scheme listed in table 1 is indicated the relation to the national building code and the classes intended for new and for existing (old/renovated and other not new) housing, respectively. The schemes specify class criteria concerning several acoustic aspects. The schemes and main class criteria are described in more detail in [8-9], for facades in [17]. Aspects related to sound classes for renovated housing are described in [18]. More schemes are under development in other countries, unfortunately different from and not coordinated with update of other schemes.



**Figure 4.** Seven of nine sound classification schemes in Europe are published by national standardization organizations. Only in Germany and France, the schemes are published by "private" organizations. An overview of schemes is found in Table 1.

**Table 1.** Overview European schemes for sound classification of dwellings, relation to building codes and indication of classes intended for new and “old” dwellings

Country	Class denotations <sup>(1)</sup>	CS Reference (latest version)	Link BC to CS	BC Reference to CS	Comment	Classes for new dwellings	Classes for “old” dwellings
DK	A / B / C / D	DS 490 (2007)	+	Class C		A, B, C	D
FI	A / B / C / D	SFS 5907 (2004)	(-)	None	BC = Class C	A, B, C	D
IS	A / B / C / D	IST 45 (2003)	(-)	None <sup>(3)</sup>	(3)	A, B, C	D
NO	A / B / C / D	NS 8175 (2008)	+	Class C		A, B, C	D
SE	A / B / C / D	SS 25267 (2004)	+	Class C		A, B, C	D
LT	A / B / C / D / E	STR 2.01.07 (2003)	+	Class C		A, B, C	D, E
NL	I / II / III / IV / V	NEN 1070 (1999)	-	None	BC ~ Class III	I / II / III	IV, V
DE	III / II / I	VDI 4100 (2007) (5)	-	None	BC ~ Class I	III, II, I	None
FR	QLAC / QL <sup>(2)</sup>	Qualitel (2008)	-	None	(4)	QLAC / QL	None

Abbreviations: BC = Building Code (regulatory requirements); CS = Classification scheme

(1) Classes are indicated in descending order, i.e. the best class first.

(2) The indicated class denotations are applied for sound insulation between dwellings, but there is only one performance level for e.g. facade sound insulation.

(3) For sound insulation between dwellings, BC recommends limit values as for Class C, although the regulatory requirements in the BC are weaker than Class C.

(4) Class/label QL for airborne sound insulation between dwellings equals BC requirement. For impact sound level, QL is 3 dB stricter than the BC.

(5) In addition, the German Society of Acoustics (DEGA) has published a recommendation for labelling of acoustic quality of new and existing buildings, cf. DEGA-Empfehlung 103, “Schallschutz im Wohnungsbau – Schallschutzausweis”, March 2009. <http://dega-schallschutzausweis.de/>. The labelling system has seven classes described by the letters A-F and a colour code, the lower classes intended for old buildings.

Considering the classification schemes in Europe, there are several differences: Descriptors used to describe sound insulation criteria; Number of quality classes and intervals between classes; Use of low-frequency spectrum adaptation terms according to ISO 717:1996; Sound insulation internally in dwellings; Common or separate quality levels for multi-storey and row housing; Balance between criteria for airborne and impact sound insulation; Relation to legal requirements. – Even the Nordic schemes are more different than appearing from Table 1.

#### 4. COST TU0901 AS A TOOL FOR HARMONIZATION IN EUROPE

Sound insulation descriptors, regulatory requirements and classification schemes in Europe represent a high degree of diversity. Unfortunately, there is no sign on increasing harmonization, rather the contrary, i.e. evidence for an even more diverse situation in Europe. The studies conclude that harmonization of descriptors and sound insulation classes are needed to facilitate exchange of data and experience between countries and to reduce trade barriers. Most important is, however, that review and update/upgrade of sound insulation requirements should be initiated in several countries to adapt regulations to current construction trends and peoples' needs for health, wellbeing and comfort.

##### Establishing COST TU0901

To coordinate research and initiate harmonization, a preliminary proposal was sent to COST in September 2008. The European Action, COST TU0901 "Integrating and Harmonizing Sound Insulation Aspects in Sustainable Urban Housing Constructions" [10], was approved in 2009 and runs for four years. Until now (June 2010), 26 countries have signed up for TU0901, and about 80 people have been nominated for the management committee and working groups. Participating COST countries are: AT, BE, HR, DK, EE, FI, MK, FR, DE, GR, HU, IS, IT, LT, NL, NO, PL, PT, RO, RS, SK, SI, ES, SE, CH, UK. For detailed information about the Action, the MC members and the activities, see [10].



**About COST:** See [http://www.cost.esf.org/about\\_cost](http://www.cost.esf.org/about_cost), main characteristics are quoted below. COST – European COoperation in the field of Scientific and Technical Research – was the first and is the widest European network for the coordination of nationally funded research activities. It is based on an inter-governmental framework for cooperation agreed following a Ministerial Conference in 1971. The mission of COST is to strengthen Europe in scientific and technical research through the support of European cooperation and interaction between European researchers. A “Bottom-up” approach (idea and subject of a COST Action comes from the European scientists themselves), equality of access (open to all COST countries) and a flexible structure are main characteristics of COST.

### **TU0901 objectives**

#### Main objectives

- Propose harmonized descriptors for airborne and impact sound insulation.
- Propose a European acoustic classification scheme for dwellings.

#### Secondary objectives

- Include low frequency range adequately
- Prepare a uniform questionnaire on annoyance by neighbour noise
- Provide a correlation between sound insulation and annoyance
- Establish a catalogue of sound insulation data for construction solutions found in the different participating countries
- Produce an on-line compendium on good workmanship practice

### **TU0901 Working Groups**

#### **WG1: Harmonized sound insulation descriptors and classification schemes in Europe**

**Topics:** Common descriptors, classification schemes, legislation, enforcement, harmonization, rating and prediction methods (ISO and EN standards) for all member states in the fields of airborne and impact sound insulation of dwellings.

**Examples current tasks:** Evaluate scientifically the suitability of different performance descriptors. Make recommendations for descriptors to be applied in future building regulations. Discuss how to involve national building authorities in a change process.

#### **WG2: Subjective evaluation of sound insulation - Laboratory tests and harmonized field surveys**

**Topics:** Collection and interpretation of research data in the participating countries about the social surveys and psychoacoustic evaluation of neighbour noise: annoyance, impact on health, quality of life, correlation with acoustic comfort.

**Examples current tasks:** Collect, analyze, compare questionnaires and results from social surveys and experience from laboratory listening tests. Make summaries of studies. Make research proposals.

#### **WG3: Design and acoustic performance of building constructions for multi-storey housing**

**Topics:** Collection and discussion of construction details and sound insulation data. Prepare a European database with traditional and innovative "robust" solutions for sound insulation of new dwellings and for improvement of existing dwellings.

**Examples current tasks:** Collect information from countries to mosaic project “Existing and New Build Dwelling Stock Profiles” about housing types and sound insulation. Make proposals for presentation of sound insulation data, construction details and typical construction errors in a database.

#### **Management Committee and Working Groups, examples of current tasks**

Review research results available and ongoing national research projects, identify gaps in the research needed to meet the objectives of the Action and initiate applications for funding. Establish efficient and effective cooperation between working groups.

Cooperation with standardization groups (several TU0901 members are active in standardization).

Establish coordination with COST Actions FP0702 (Acoustics for Timber based Lightweight Buildings), TU0701 (Improving the Quality of Suburban Building Stock), TD0804 (Soundscapes).

#### **Is harmonization of sound insulation descriptors and classes possible?**

Looking into the future, harmonization of sound insulation requirements seems unrealistic. However, by reducing the number of sound insulation descriptors and by preparing a harmonized European classification scheme with a number of quality classes, each member states could select for regulations a "harmonized" class fitting the national needs and conditions.

## Jungles to fell – Replanting forbidden!

Jungle 1: A variety of standardized sound insulation descriptors, cf. EN ISO 717, [11]

Jungle 2: Complex national rules to find the relevant limit values, see eg. [12]

Jungle 3: National special rules in addition to standardized methods, cf. eg. [13-14]

## Implementation – Important tools

Important tools for improvement of sound insulation in practice are: Review of national requirements and upgrade, if needed; Suitable predictions and test methods (EN 12354 and ISO 140); Knowledge of uncertainties (see eg [19]); Construction databases and guidelines for improvement of existing housing and for new housing; Enforcement of regulations; Feedback.

## Examples of guidelines and enforcement

Examples of instructions for improvement of existing/old housing are found in Figure 5. For new buildings, “Robust Details” [20] implemented in UK is an example of a coordinated approach, including construction design, acoustic site inspection, checklists, field testing and systematic feedback to the design and performance review. In practice, Robust Details supports enforcement. Examples of construction details and checklists are shown in Figure 6.

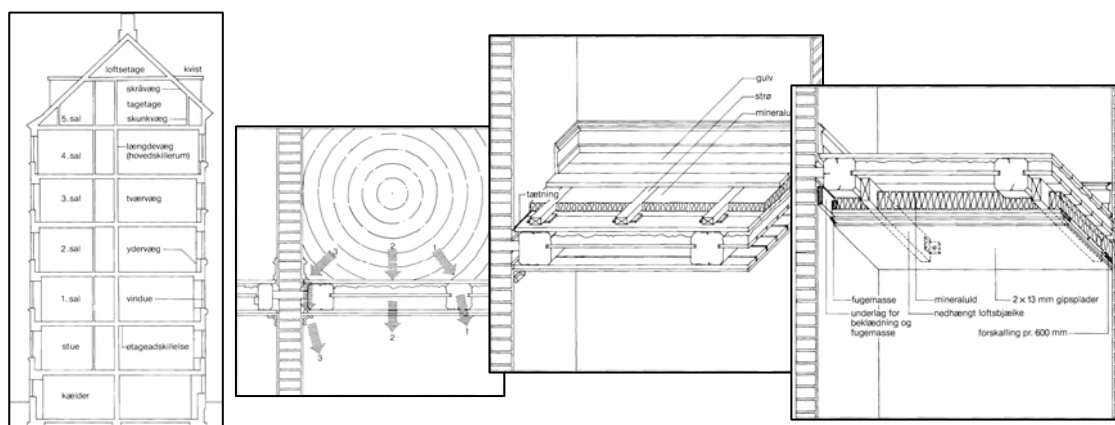

**Figure 5.** Examples on instructions for improvement of sound insulation of old housing.  
Source: SBi Guidelines 173, Sound insulation of buildings – Old buildings, 1992 (in Danish).

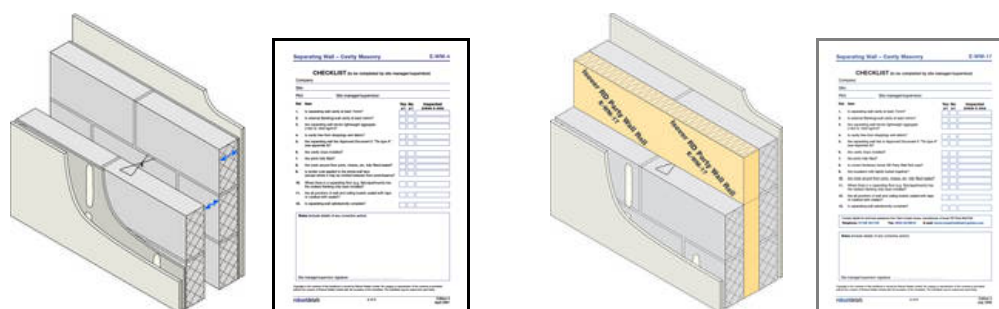

**Figure 6.** Examples construction details and related checklists from Robust Details [20].

According to [21], the coordinated approach “can lead to an accelerated uptake in improved construction practice and allow government policy performance objectives to be met sooner”.

## 6. CONCLUSIONS

Most European countries have regulatory sound insulation requirements for dwellings, and classification schemes exist in several countries. However, descriptors and performance levels represent a high degree of diversity. A harmonization is necessary to stimulate innovation and reduce trade barriers and – most important – facilitate the exchange of experience between countries, thus improving chances of better quality of dwellings to the benefit of peoples’



comfort. COST TU0901 has – through members with different academic backgrounds (architects, physicists, civil engineers etc.) and from different types of institutions (universities, building research institutes, authorities, private companies etc.) in 26 countries in Europe – the potential to establish a change process in a direction ensuring strengthened scientific basis for changes in sound insulation requirements and classes.

## 7. REFERENCES

- [1] Preamble to the Constitution of the World Health Organization as adopted by the International Health Conference, New York, 19 - 22 June 1946; signed on 22 July 1946 by the representatives of 61 states (official Records of the World Health Organization, No. 2, p. 100) and entered into force on 7 April 1948.
- [2] <http://www.euro.who.int/>
- [3] Van den Berg, M. "Neighbour Noise: A rational Approach", pp. 151-154 in Proceedings of the 2nd WHO International Housing and Health Symposium. WHO, Bonn (2004).
- [4] J Lang, R Pierrard, W Schönböck, "Sound Insulation in Housing Construction", TU Wien, Vienna, July 2006. A summary is found in J Lang (2007), "Schallschutz im Wohnungsbau". WKS 59/2007.
- [5] <http://www.europa.eu>
- [6] B Rasmussen, "Sound insulation between dwellings – Requirements in building regulations in Europe". Applied Acoustics, 2010, 71(4), 373-385. <http://dx.doi.org/10.1016/j.apacoust.2009.08.011>
- [7] B Rasmussen & JH Rindel "Sound insulation between dwellings – Descriptors in building regulations in Europe". Applied Acoustics, 2010, 71(3), 171-180. <http://dx.doi.org/10.1016/j.apacoust.2009.05.002>
- [8] B Rasmussen, "Sound insulation of residential housing - Building codes and classification schemes in Europe". Chapter 114 in Handbook of Noise and Vibration Control. Wiley & Son, USA, 2007.
- [9] B Rasmussen, "Sound classification of dwellings – Comparison of schemes in Europe", NAG/DAGA 2009, Rotterdam, Netherlands. Paper ID 453.
- [10] COST Action TU0901 "Integrating and Harmonizing Sound Insulation Aspects in Sustainable Urban Housing Constructions", 2009-2013, [www.cost.eu/index.php?id=240&action\\_number=tu0901](http://www.cost.eu/index.php?id=240&action_number=tu0901) (public information at COST website) or <http://www.costtu0901.eu/> (Action website).
- [11] ISO 717, Acoustics - Rating of sound insulation in buildings and of buildings elements.  
– Part 1: Airborne sound insulation, 1996.  
– Part 2: Impact sound insulation, 1996.  
Note: In 2008, ISO/TC 43/SC 2 decided to revise ISO 717. The revision is made by WG 18.
- [12] V Desarnaulds and B Rasmussen, "Harmonisation des réglementations européennes dans le domaine de l'isolation acoustique dans le bâtiment (COST TU0901)". 10ème Congrès Français d'Acoustique, Lyon, 12-16 Avril 2010.
- [13] Heikki Helimäki and Birgit Rasmussen, "Airborne sound insulation descriptors in the Nordic building regulations – Overview special rules and benefits of changing descriptors". Baltic-Nordic Acoustics Meeting 2010, Bergen, Norway. SINTEF Byggeforsk, 2010.
- [14] Klas Hagberg and Birgit Rasmussen, "Impact sound insulation descriptors in the Nordic building regulations – Overview special rules and benefits of changing descriptors". Baltic-Nordic Acoustics Meeting 2010, Bergen, Norway. SINTEF Byggeforsk, 2010.
- [15] Barlindhaug, Rolf, & Ruud, Marit Ekne. "Beboernes tilfredshet med nybygde boliger" (Resident satisfaction with newly built homes). Norsk institutt for by- og regionforskning. NIBR-rapport 2008:14, Oslo 2008.
- [16] Sigurd Hveem, "Unngå byggsaker – Lydisolasjonskvalitet i boliger" (Avoid building faults – Sound insulation quality in dwellings). SINTEF Byggeforsk, 2010. <http://www.sintef.no/upload/Artikkel-05-10-ByggAktuelt.pdf>. Note: This article summarizes main findings about sound insulation from [14].
- [17] B Rasmussen, "Facade sound insulation comfort criteria in European classification schemes for dwellings", EuroNoise 2006, Tampere, Finland, Paper ID 434.
- [18] B Rasmussen, "Sound classification schemes in Europe - Quality classes intended for renovated housing". SUBURBAN 2010 "Improving the Quality of Suburban Building Stock". University of Malta, 2010.
- [19] Christian Simmons, "Managing uncertainty in building acoustics: comparisons of predictions with the 12354 standards to measurements". Dissertation, Luleå University of Technology, 2009.
- [20] Robust Details, <http://www.robustdetails.com/>. Definition of RD: see <http://www.robustdetails.com/Robust-Details-for-Part-E-separating-walls-or-floors-sound-insulation-and-testing-Robust-Details-Limited-65d22b1>
- [21] Smith S et al. "The development of robust details for sound insulation in new build attached dwellings". J Build Appraisal 2006;2 (1):69–85.