



**AALBORG UNIVERSITY**  
DENMARK

**Aalborg Universitet**

## **Benchmarking of Grid Fault Modes in Single-Phase Grid-Connected Photovoltaic Systems**

Yang, Yongheng; Blaabjerg, Frede; Zou, Zhixiang

*Published in:*  
IEEE Transactions on Industry Applications

*DOI (link to publication from Publisher):*  
[10.1109/TIA.2013.2260512](https://doi.org/10.1109/TIA.2013.2260512)

*Publication date:*  
2013

*Document Version*  
Early version, also known as pre-print

[Link to publication from Aalborg University](#)

*Citation for published version (APA):*  
Yang, Y., Blaabjerg, F., & Zou, Z. (2013). Benchmarking of Grid Fault Modes in Single-Phase Grid-Connected Photovoltaic Systems. *IEEE Transactions on Industry Applications*, 49(5), 2167-2176.  
<https://doi.org/10.1109/TIA.2013.2260512>

### **General rights**

Copyright and moral rights for the publications made accessible in the public portal are retained by the authors and/or other copyright owners and it is a condition of accessing publications that users recognise and abide by the legal requirements associated with these rights.

- ? Users may download and print one copy of any publication from the public portal for the purpose of private study or research.
- ? You may not further distribute the material or use it for any profit-making activity or commercial gain
- ? You may freely distribute the URL identifying the publication in the public portal ?

### **Take down policy**

If you believe that this document breaches copyright please contact us at [vbn@aub.aau.dk](mailto:vbn@aub.aau.dk) providing details, and we will remove access to the work immediately and investigate your claim.

# Benchmarking of Grid Fault Modes in Single-Phase Grid-Connected Photovoltaic Systems

Yongheng Yang

Student Member, IEEE  
Aalborg University  
Pontoppidanstraede 101  
Aalborg, DK-9220, Denmark  
yoy@et.aau.dk

Frede Blaabjerg

Fellow, IEEE  
Aalborg University  
Pontoppidanstraede 101  
Aalborg, DK-9220, Denmark  
fbl@et.aau.dk

Zhixiang Zou

Student Member, IEEE  
Southeast University  
No. 2 Sipailou  
Nanjing, 210096, China  
zou.zhixiang@seu.edu.cn

**Abstract** -- Pushed by the booming installations of single-phase photovoltaic (PV) systems, the grid demands regarding the integration of PV systems are expected to be modified. Hence, the future PV systems should become more active with functionalities of Low Voltage Ride-Through (LVRT) and grid support capability. The control methods, together with grid synchronization techniques, are responsible for the generation of appropriate reference signals in order to handle ride-through grid faults. Thus, it is necessary to evaluate the behaviors of grid synchronization methods and control possibilities in single phase systems under grid faults.

The intent of this paper is to present a benchmarking of grid fault modes that might come in future single-phase PV systems. In order to map future challenges, the relevant synchronization and control strategies are discussed. Some faulty modes are studied experimentally and provided at the end of this paper. It is concluded that there are extensive control possibilities in single-phase PV systems under grid faults. The Second Order General Integral based PLL technique might be the most promising candidate for future single-phase PV systems because of its fast adaptive-filtering characteristics and it is able to fulfill future standards.

**Index Terms** – Single-Phase Photovoltaic Systems, Grid Requirements, Low-Voltage Ride-Through, Grid Support, Grid Synchronization, Phase Locked Loop.

## I. INTRODUCTION

The installation of single-phase PV systems has been booming in recent years because of the matured PV technology and the declined price of PV panels [1], [2]. Pushed by the high penetration of renewable energy systems, many grid requirements have been released in order to regulate interconnected renewable power generation [4]-[8]. Some basic requirements are defined in the grid regulations, like power quality, frequency stability and voltage stability [3], [9], [16] and even more specific demands for wind turbines or high-voltage systems have been issued [6].

Traditionally, the grid-connected PV systems are small-scale at a residential level and designed to disconnect from the grid within a certain time tripping by a grid fault [3]. However, due to the thriving scenario of large-scale grid-connected single-phase PV systems in many distributed installations, the disconnection could cause adverse

conditions and negatively impact the reliability, stability and availability of the distributed grid [10]-[15]. For instance, the voltage fault may cause lighting flickers, low voltage and power quality problems, leading to the loss in energy production and the necessity of PV integration limitation. However, if the grid-connected single-phase PV systems can provide ancillary services, such as reactive power support and Low Voltage Ride Through (LVRT) capability [16]-[21], the customers will not experience many flickers and power quality issues anymore, and the Distributed System Operators will not need to limit the PV integration into their grids. It is expected that in the near future the grid-connected PV systems should become more active and more “smart” with such functionalities because of the high penetration of PV systems.

In that case, the control methods should be ready for single-phase PV applications, because they are responsible for generating appropriate reference signals in order to handle ride-through grid faults, which means an evaluation and benchmarking of possible control strategies for single-phase applications are necessary. Practically, the single-phase  $PQ$  theory [22], [23] could be adopted in the control system. By regulating the maximum power point, the active power could be controlled within the boundaries in order to avoid over-current tripping under grid voltage sags in such a way to enhance the low voltage ride through capability. Furthermore, the droop control methods could be used to adjust the active and reactive powers as reported in [24], [25].

Moreover, as the prerequisite of a good control, the synchronization technique for single-phase PV systems has also become of high interest. Since a voltage fault is normally a short period, an accurate and fast synchronization method will ensure a good performance of the whole PV system in the grid faulty mode operation. Recent research demonstrates that the phase locked loop (PLL) based synchronization methods have more attractiveness for such applications [6], [8], [26]-[30]. Among these, the adaptive mechanism based techniques gain more attention because of their high robustness and fast response characteristics. Such kinds of methods may be the best candidates for single-phase PV systems operating in faulty-grid modes. However, it may also cause undesired influences, which have been discussed in [31].

The objective of this paper is to study the performance of single-phase grid-connected PV systems under grid faults defined by the basic grid codes of wind turbine systems connected to the grid. Firstly, an overview of the existing grid requirements is presented. Particular attention is paid on the possible control strategies, which may help the single-phase PV systems to handle ride-through grid faults or operate under abnormal grid conditions. It is followed by an evaluation of the synchronization methods. Finally, faulty cases are simulated and validated experimentally.

## II. OVERVIEW OF SELECTED GRID REQUIREMENTS

One essential basis of the design and control for grid-connected PV inverters is the grid requirements. In some international regulations [3], it is addressed that PV inverters should disconnect from the grid in the presence of abnormal grid conditions in terms of voltage and frequency at the point of common coupling. These requirements, including islanding protection, are designed based on a low-level penetration of PV systems and are set to ensure the safety of utility maintenance personnel and also the grid. Compared to the conventional power plants and wind power systems, typically PV systems are connected to low-voltage and/or medium-voltage networks [2]. In this case, such grid requirements are valid and enough.

However, considering the impact of large-scale PV systems on a distributed grid to which they are connected, these grid requirements are supposed to be revised or extended with some combined standardized features as well as custom demands. Because the disconnections from the distributed grid can affect the stability of the whole system and cause negative impacts on customers' equipment, several European countries have updated the grid requirements for medium- or high-voltage systems. For instance, the German grid code requires that the systems connected to the medium- or high-voltage networks should have the capabilities of low voltage ride-through (LVRT) and grid support functionality during grid faults [4], [5]. In the new Italian grid code, it is required that the generation units connected to low-voltage grid with the nominal power exceeding 6 kVA should have the ability to ride through grid voltage faults [16].

Therefore, it is better for PV inverters to be equipped with low voltage ride through capability in order to improve the operation of the power converters and the reliability of the whole system. It is expected that the above regulations will be extended for large-scale low-voltage PV applications [12]-[14], [17]-[21]. Similar to wind turbine power generations connected to the medium- and high-voltage levels, single-phase PV generation systems supplying low-voltage networks in the future are supposed to make a contribution to the network by means of also riding through grid faults.

Different LVRT curves of a defined stay-connected time are presented in Fig. 1. As it is noticed in Fig. 1 that the generation systems required in the German grid code should be capable of riding through 0.15 seconds voltage fault when

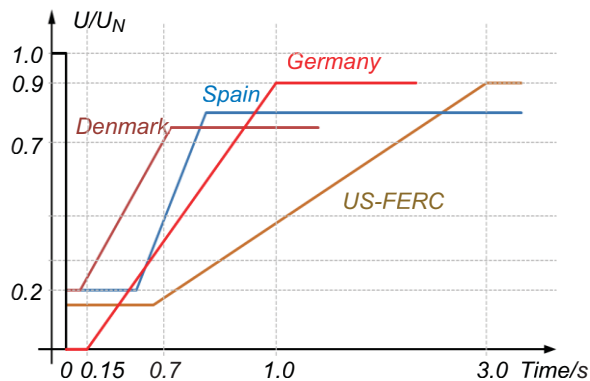

Fig. 1. Low voltage ride-through requirements of wind power systems of different countries [4].

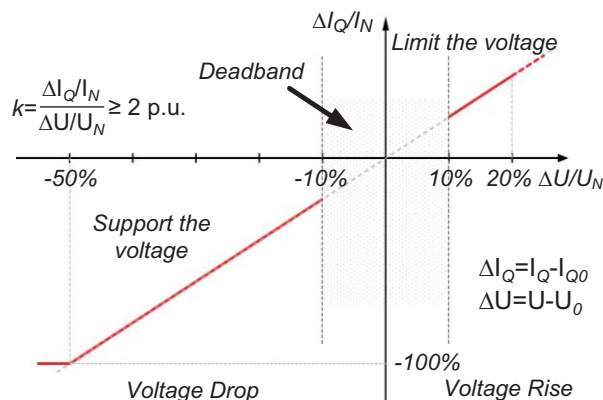

Fig. 2. Voltage support requirements in the event of grid faults for wind turbine systems [5].

the grid voltage amplitude presents a drop to 0 V and inject some reactive current  $I_Q$  into the grid as well. The required reactive current  $I_Q$  to support the voltage in the German grid regulation is shown in Fig. 2, and it can be given as,

$$I_Q = \begin{cases} \text{deadband,} & 0.9 p.u. \leq U < 1.1 p.u. \\ k \cdot \frac{U - U_0}{U_N} \cdot I_N + I_{Q0}, & 0.5 p.u. \leq U < 0.9 p.u. \\ -I_N + I_{Q0}, & U < 0.5 p.u. \end{cases} \quad (1)$$

where  $U$ ,  $U_0$ , and  $U_N$  are instantaneous voltage, initial voltage before grid faults and the nominal voltage, and  $I_N$ ,  $I_{Q0}$  are the nominal current and the reactive current before a grid failure.

## III. CONTROL POSSIBILITIES UNDER GRID FAULTS

The traditional control strategy applied to the single-phase converter system includes two cascaded loops: an inner current loop which is responsible for power quality issues and current protection [6], [8], [32] and an outer voltage control loop. In this case, it is possible to add control methods into the inner loop in single-phase systems in grid faulty mode operations to support the grid. The overall structure of a single-phase grid-connected PV system is given in Fig. 3.

In respect to the control of a three-phase system under grid faults, four major methods are reported in the literature: unity

power factor control, positive sequence control, constant active power control and constant reactive power control [8], [32]. These methods are not suitable for single-phase applications since it is difficult to employ directly a  $dq$ -rotating synchronous reference frame.

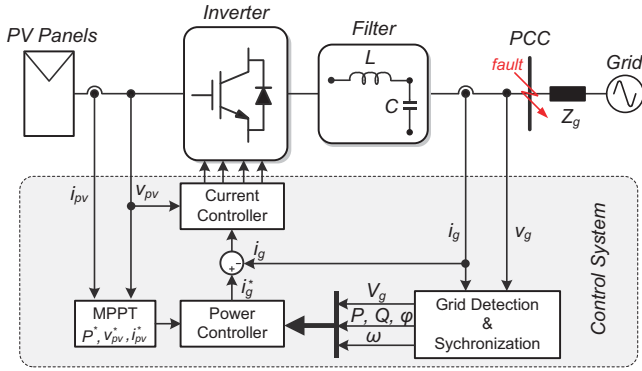

Fig. 3. Overall control structure of a single-phase grid-connected photovoltaic system.

One possible solution to the single-phase case is inspired by the Orthogonal Signal Generator (OSG) based PLL principle [6], [8], [32]. According to the single-phase active and reactive power theory [22], [23], the components,  $v_\alpha$  and  $v_\beta$ , generated by the OSG system can be used to calculate the active power and reactive power as given by,

$$\begin{cases} P = \frac{1}{2}(v_\alpha i_\alpha + v_\beta i_\beta) \\ Q = \frac{1}{2}(v_\beta i_\alpha - v_\alpha i_\beta) \end{cases}, \quad (2)$$

where  $i_{\alpha\beta}$ ,  $v_{\alpha\beta}$  are the grid current and voltage in the  $\alpha\beta$  system, and  $P$ ,  $Q$  are the active power and reactive power respectively. Thus, by this mean, the current reference can be generated as it is expressed as,

$$\begin{bmatrix} i_\alpha^* \\ i_\beta^* \end{bmatrix} = \frac{2}{v_\alpha^2 + v_\beta^2} \begin{bmatrix} v_\alpha & v_\beta \\ v_\beta & -v_\alpha \end{bmatrix} \begin{bmatrix} P^* \\ Q^* \end{bmatrix}, \quad (3)$$

in which ‘\*’ denotes the reference signal. Then the detailed control diagram based on the single-phase  $PQ$  theory and the OSG concept can be illustrated as it is shown in Fig. 4.

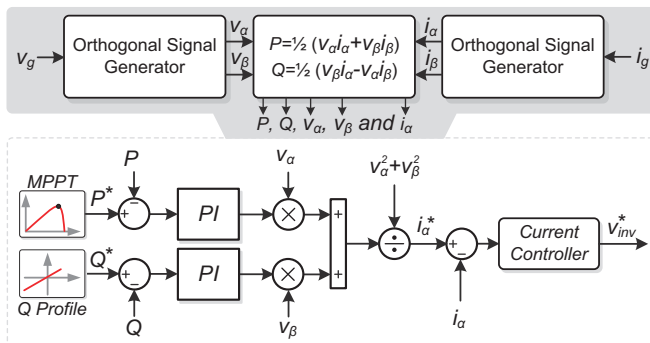

Fig. 4. Control diagram of single-phase systems under grid faults based on the single-phase  $PQ$  theory and the orthogonal signal generator concept.

Notably, in this control system, the existing current control methods, such as Proportional Resonant (PR), Resonant Control (RSC), Deadbeat control (DB), and Repetitive Controller (RC), and Hysteresis Control (HC) can be adopted in the faulty grid cases. Moreover, by employing the Park Transform ( $\alpha\beta$ - $dq$ ) to the grid current and the grid voltage, the DC quantities of the current and voltage are obtained in the rotating synchronous reference frame, leading to the possible use of the basic PI-control for the current or power regulation [23], [33], [34]. The ‘‘ $Q$  Profile’’ shown in Fig. 4 is in compliance with the grid codes as described by (1) and in Fig. 2. The reference reactive power  $Q^*$  is generated according to the voltage sag depth detected by the synchronization units or a grid fault detection scheme, which means that the ‘‘ $Q$  Profile’’ is triggered by the detected voltage amplitude  $V_g$ .

Another control possibility is based on the concept of the frequency and voltage droop control through active power and reactive power, respectively. A droop control method could be adopted to adjust the active power and reactive power in single-phase applications under grid faults. It can be illustrated using the simplified grid-connected PV system as shown in Fig. 5.

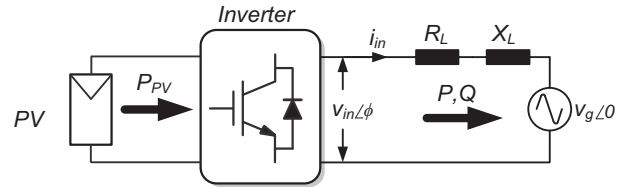

Fig. 5. A simplified single-phase grid-connected photovoltaic system.

On the basis of the assumptions that the line impedance is mainly inductive ( $X_L \gg R_L$ ) and the power angle  $\phi$  is very small, the active power  $P$  and reactive power  $Q$  can be expressed by [24], [25],

$$\begin{cases} P = \frac{V_{in} V_g \sin \phi}{X_L} \approx \frac{V_{in} V_g \phi}{X_L} \\ Q = \frac{V_{in} V_g \cos \phi - V_g^2}{X_L} \approx \frac{(V_{in} - V_g) V_g}{X_L} \end{cases}, \quad (4)$$

where  $X_L$  is the line reactance. Hence, the inverter voltage reference  $v_{in}^*$  can be obtained and it is controllable through the angle  $\phi$  and the amplitude  $V_{in}$  by respectively regulating the active power and the reactive power with simple PI controllers. A droop controller can be given as,

$$\begin{cases} \phi = \phi^* - G_1(s)(P - P^*) \\ V_{in} = V_{in}^* - G_2(s)(Q - Q^*) \end{cases}, \quad (5)$$

in which ‘\*’ indicates the reference signal and  $G_1(s)$ ,  $G_2(s)$  are the PI controllers that can control the active power and reactive power sharing between the PV inverter and the grid.

This kind of control approach used to support the grid voltage under a grid voltage sag is successfully tested in [24], [25], where the PV inverter is working as a shunt device and

designed to mitigate the grid voltage drops and the harmonic distortions. However, since the single-phase PV systems are normally connected to low-voltage distribution networks, the line is more resistive rather than inductive. Therefore, a large inductor is required between the grid and the PV inverter in this control strategy; otherwise the voltage sag cannot be well compensated. This is the main weak point of such a control. Thus, in this paper, the single-phase  $PQ$  theory based control method is adopted.

It is also worth to know that the active power delivered to the grid is limited by the inverter nominal current. Therefore, to avoid inverter shut-down because of the over-current protection, the PV panels should not operate in the maximum power point tracking (MPPT) mode depending on the solar irradiation, which can be illustrated in Fig. 6. It is shown that in the grid faulty mode operation the active power should be limited in order to deliver the required reactive power without triggering the inverter over-current protection. Nevertheless, this aspect could be used for reactive power support, e.g. during the night when there is no solar irradiance [20].

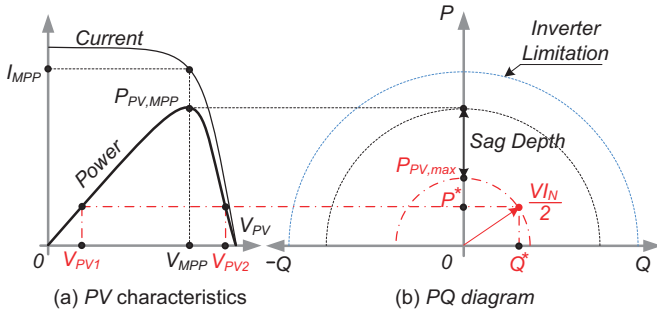

Fig. 6. Limitation of active and reactive powers drawn from PV panels (dashed black: MPPT operation, dot-dashed red: grid faulty mode).

Additionally, the double-frequency term presenting at the DC side (PV side) in single-phase systems will also have a negative impact on the control systems both under normal operation and in grid faulty mode operation [8]. Consequently, the design of the controllers, modulation techniques and grid-interfaced current filters ( $L$ ,  $LC$ , or  $LCL$ ) should be done in consideration of producing lower switching voltage stress and lower voltage ripple at the DC-link.

Anyway, there are extensive control possibilities in single-phase grid-connected PV systems, which are able to meet the upcoming requirements defined in the grid codes. Regarding single-phase PV systems with grid support and LVRT functionalities, the control method should be capable of providing accurate and appropriate references without exceeding the DC nominal voltage, tripping the current protection due to constant active power delivery and failing to synchronize in compliance with these demands in the near future.

#### IV. GRID SYNCHRONIZATION TECHNIQUES FOR SINGLE-PHASE APPLICATIONS

The synchronization scheme plays a major role in the control of single-phase systems under grid faults. A good synchronization system should respond to a voltage drop

immediately when a phase-to-ground fault occurs at PCC as shown in Fig. 3. Many synchronization methods are reported in recent literature [6], [8], [26]-[30], which can be divided into two categories - mathematical analysis methods (e.g. Fourier analysis based synchronization method) and PLL-based methods. Nowadays, the PLL based synchronization methods have more attractiveness. However, the main difference among various single-phase PLL methods is the configuration of the phase detector, intuitively, being a simple sinusoidal multiplier [26], [29]. However, this process will produce a double-frequency term in a single-phase system.

Applying the Park Transform to an OSG system is another way to extract the phase error for PLL based methods. Hence, the task will be shifted to establish the OSG system. Such kinds of PLL are reported in the literature, like T/4 Delay PLL [6], [8], [27] and Inverse Park Transform based PLL (IPT-PLL) [6], [26], [27]. Other possibility is to use adaptive filters which can self-adjust the output according to an error feedback loop. Two popular PLLs - the Enhanced PLL (EPLL) [26], [34], [35] and the Second Order Generalized Integrator based PLL (SOGI-OSG) [6], [8], [27], [37], are based on the combinations of adaptive filters with a sinusoidal multiplier and an OSG system.

A basic PLL structure is given in Fig. 7, which consists of a phase detector (PD), a proportional-integral (PI) based loop filter (LF) and a voltage-controlled oscillator (VCO). Thus, the small signal model of this system can be given as,

$$\frac{\hat{\Theta}(s)}{\Theta(s)} = \frac{K_p s + K_i}{s^2 + K_p s + K_i}, \quad (6)$$

where  $\hat{\Theta}(s)$ ,  $\Theta(s)$  are the output and input phase respectively, and  $K_p$ ,  $K_i$  are the proportional and integral gains of the loop filter. The details of the PLL modeling can be found in [6]. From (6), the settling time can be given by  $t_s = 9.2/K_p$ , which is adopted to evaluate the performance of different PLLs in this paper. The following section will compare the selected PLLs and find the best one for the application in this paper.

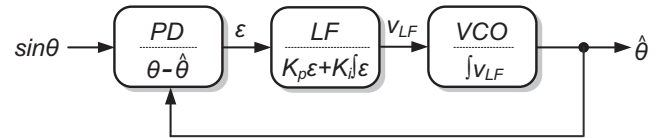

Fig. 7. Basic structure of a phase locked loop.

#### A. T/4 Delay PLL

This PLL approach takes the input voltage  $v_g$  as the “ $\alpha$ ” component in a “ $\alpha\beta$ ” system, while the “ $\beta$ ” component can be obtained simply by introducing a phase shift of  $\pi/2$  rad with respect to the fundamental frequency of the input voltage. Thus the Park Transform can be employed to detect the phase error, which is expressed as the following,

$$\begin{bmatrix} v_d \\ v_q \end{bmatrix} = \begin{bmatrix} \cos \hat{\theta} & \sin \hat{\theta} \\ -\sin \hat{\theta} & \cos \hat{\theta} \end{bmatrix} \begin{bmatrix} v_g \\ v_\beta \end{bmatrix} = \begin{bmatrix} V_m \sin(\Delta\theta) \\ -V_m \cos(\Delta\theta) \end{bmatrix} \approx \begin{bmatrix} V_m \Delta\theta \\ -V_m \end{bmatrix} \quad (7)$$

where  $v_g = V_m \sin(\theta) = V_m \sin(\omega t + \phi)$ , in which  $V_m$ ,  $\theta$ ,  $\omega$  and  $\phi$  are the amplitude, phase, frequency and phase angle of the input signal  $v_g$ ,  $\Delta\theta = \theta - \hat{\theta}$  is the detected phase error, and  $\hat{\theta}$  is the locked phase.

Actually, the error  $\Delta\theta$  is very small in steady state, and then the linearized equation shown in the very right side of (7) is obtained. The structure of the T/4 Delay PLL is given in Fig. 8, where  $T$  and  $\omega_0$  are the period and nominal frequency of the input voltage  $v_g$ .

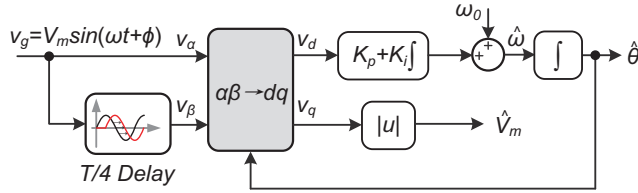

Fig. 8. Structure of the T/4 Delay PLL.

### B. Enhanced PLL

The Enhanced PLL (EPLL) introduced in [31], [35] is based on a simple adaptive filter (AF), which can refine the transfer function according to a feedback algorithm driven by an error signal. It can be used to track the input voltage in terms of amplitude  $V_m$  and phase  $\theta$ .

The adaptive process is to minimize a so-called objective function by modifying the filter parameters. Then the amplitude is estimated. Define the objective function as,

$$E(\hat{V}_m, \hat{\theta}) = \frac{1}{2} e^2 = \frac{1}{2} (v_g - \hat{v}_g)^2, \quad (8)$$

in which  $\hat{V}_m$  and  $\hat{\theta}$  are the estimated amplitude and the locked phase of the input voltage, respectively. Then, the desired output of the filter can be expressed as  $\hat{v}_g = \hat{V}_m \sin \hat{\theta}$ .

In order to minimize the objective function, the popular least-mean-square (LMS) adaptive algorithm is used [36]. Then the following differential equation is obtained [31],

$$\dot{\hat{V}}_m = -\mu \frac{\partial E(\hat{V}_m, \hat{\theta})}{\partial \hat{V}_m} = \mu e \sin \theta, \quad (9)$$

where  $\mu$  is the control parameter. Subsequently, the PD implementation of the Enhanced PLL can be given in Fig. 9.

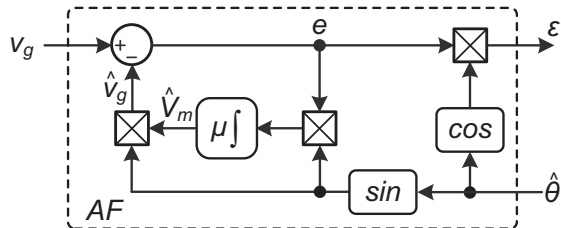

Fig. 9. Adaptive filter based phase detector of the Enhanced PLL.

One important feature of the EPLL concluded from the above discussion is that the output signal  $\hat{v}_g$  is locked both in phase and in amplitude compared to the conventional PLL

methods [35]. However, the performance, such as the speed of the estimation process, is exclusively dependent on the control parameter  $\mu$ . By linearizing (9), this relationship can be obtained as [35],

$$\frac{\hat{V}_m(s)}{V_m(s)} = \frac{1}{\tau s + 1}, \quad (10)$$

where  $\tau = 2/\mu$  is the time constant.

The response of such an adaptive filter in the EPLL system with different time constants is shown in Fig. 10. It is noticed that a large value of  $\mu$  will make the estimated output signal coming to steady-state quickly, but it will have a high overshoot of frequency if  $\mu$  is too large. The settling time of this system can approximately be calculated as:  $4\tau = 8/\mu$ .

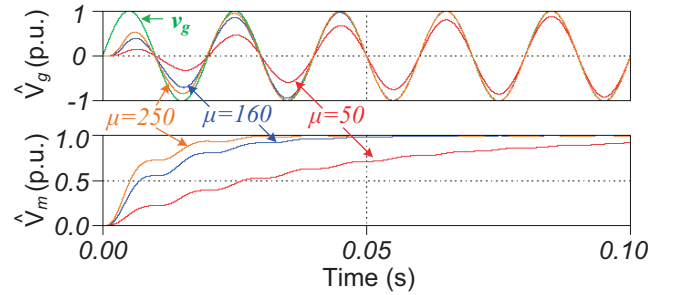

Fig. 10. Response of the adaptive filter of an enhanced PLL with different  $\mu$  (different time constant,  $\tau$ ).

### C. Second Order Generalized Integrator based PLL

Another adaptive filtering based PLL solution is using Second Order Generalized Integrator (SOGI) to create the OSG system, commonly known as SOGI-OSG PLL [6], [32], [37]. The general OSG structure of SOGI-OSG PLL is depicted in Fig. 11, in which  $\hat{\omega}$  is the estimated frequency of the input signal,  $q\hat{v}_g$  is the orthogonal signal with respect to the input voltage  $v_g$  and  $k_e$  is the control parameter.

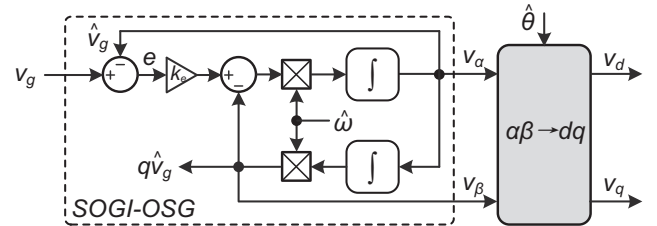

Fig. 11. Phase detector of the second order generalized integrator PLL.

Actually, the EPLL discussed above is using only one-weight adaptive filter, which is the simplest one. If two-weight adaptive filters are adopted in single-phase applications, it will present a better performance and it behaves like a “sinusoidal integrator” [6], [37], [38]. The transfer function of such kind of adaptive filter can be expressed as,

$$G_{AF}(s) = \frac{s}{s^2 + \hat{\omega}^2}. \quad (11)$$

Multiplied by  $\hat{\omega}$  which is defined previously, it shares the transfer function of a second order generalized integrator in common [37], [39].

Thus, referring to Fig. 11, the closed loop transfer functions of the SOGI-OSG PLL can be obtained as,

$$\begin{cases} \frac{\hat{v}_g(s)}{v_g(s)} = \frac{k_e \hat{\omega} s}{s^2 + k_e \hat{\omega} s + \hat{\omega}^2}, \\ \frac{q\hat{v}_g(s)}{v_g(s)} = \frac{k_e \hat{\omega}^2}{s^2 + k_e \hat{\omega} s + \hat{\omega}^2}. \end{cases} \quad (12)$$

The detailed derivation of these transfer functions can be found in [6] and [37]. In order to evaluate the performance of SOGI-OSG PLL, the settling time is given as,

$$t_s = \frac{9.2}{k_e \hat{\omega}}.$$

#### D. Comparison of the PLLs

In order to find the most suitable solution for the single-phase grid-connected PV system in low voltage ride-through operation, the above synchronization methods are compared in faulty grid cases by simulations and experiments with the parameters shown in TABLE I. The experimental setup is shown in Fig. 12. This system consists of two Delta DC sources connected in series, forming the nominal DC voltage  $V_{dc} = 400 V$  and a three-phase Danfoss 5 kW VLT inverter which is configured as a single-phase system. An LC-filter is used in this arrangement and it is connected to the grid through a three-phase transformer with the leakage inductance of  $L_T = 4 mH$ . The nominal grid parameters and other parameters are shown in TABLE I.

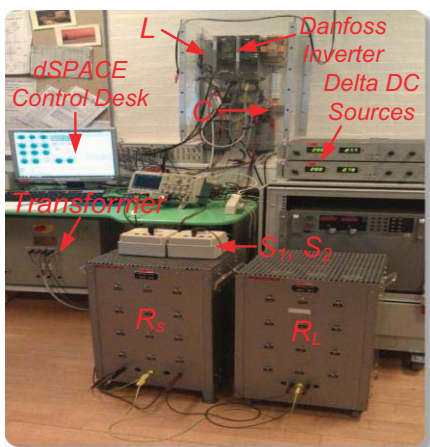

Fig. 12. Experimental setup.

The results shown in Fig. 13 and Fig. 14 are obtained when the grid has a 0.45 p.u. voltage sag by switching the resistors  $R_s$  and  $R_L$ . More comparisons of these PLLs by simulations in terms of the settling time and the overshoot of frequency are provided in TABLE II where different changes are done like frequency jump and phase jump, and it can be used to select appropriate methods for different applications.

TABLE I  
SIMULATION AND EXPERIMENTAL PARAMETERS

Grid Voltage Amplitude	$V_N = 230 V$
Grid Frequency	$\omega_0 = 2\pi \times 50 \text{ rad/s}$
LC Filter	$L = 3.6 mH, C = 2.35 \mu F$
Transformer Leakage Inductance and Resistance	$L_T = 4 mH, R_g = 0.02 \Omega$
Sampling and Switching Frequency	$f_s = f_{sw} = 10 \text{ kHz}$
Voltage sag generator	$R_s = 19.2 \Omega, R_L = 20.1 \Omega$

TABLE II  
COMPARISON OF THE PLLS

	T/4 Delay	EPLL	SOGI-OSG
Voltage Sag (0.45 p.u.)	4.7 ms	7.8 ms	8 ms
	0.26 Hz	0.91 Hz	0.62 Hz
Phase Jump (+90°)	75 ms	120 ms	72 ms
	16.1 Hz	16 Hz	19.1 Hz
Frequency Jump (+1 Hz)	Oscillate	186 ms	111 ms
	(-1.2, 1.2) Hz	8.4 Hz	10.4 Hz
OSG Mechanism	✓	✗	✓
Complexity	★	★★★	★★

As it can be seen in the results, the performances of these PLL methods are not very good during the voltage sag. The T/4 Delay method can follow the amplitude change quickly (a quarter of the grid nominal period approximately), while it cannot be a good synchronization technique when the grid is subjected to frequency variations. Although, the main merit of an EPLL is that it can estimate both the amplitude and the frequency of the input voltage without doubling the input frequency oscillations. This kind of PLL method presents a slow transient variation as shown in Fig. 13 and Fig. 14. This variation demonstrates how the adaptive filter minimizes the objective function. With respect to the control of single-phase systems, the EPLL method is not suitable for calculating the active power and the reactive power because it is not based on the OSG concept, but it can be used to control the instantaneous power [34]. The SOGI-OSG PLL can track the input voltage with better performance compared to T/4 Delay PLL and EPLL especially when the grid presents a frequency variation/jump as shown in TABLE II. It can be concluded that, together with a fast detection unit, the SOGI-OSG PLL is the best candidate for single-phase applications. Thus, in this paper, this synchronization method is selected.

#### V. SYSTEM RIDE-THROUGH OPERATION

A simple case is examined by simulation under the voltage sag in order to give a basic demonstration about single-phase systems under grid faults and also validated experimentally.

Referring to Fig. 4 and Fig. 12, a PR controller with harmonics compensation is used as the current controller and, based on the comparison in § IV, the SOGI-OSG PLL is adopted to detect the grid fault and to synchronize with the grid. The parameters of the PI controller for active power are  $K_{pp} = 1.5$  and  $K_{pi} = 52$ , while for reactive power are  $K_{qp} = 1$  and  $K_{qi} = 50$ . The rated power is set to be 1 kW. The other parameters for the experiments are shown in TABLE I. The results are shown in Fig. 15 and Fig. 16.

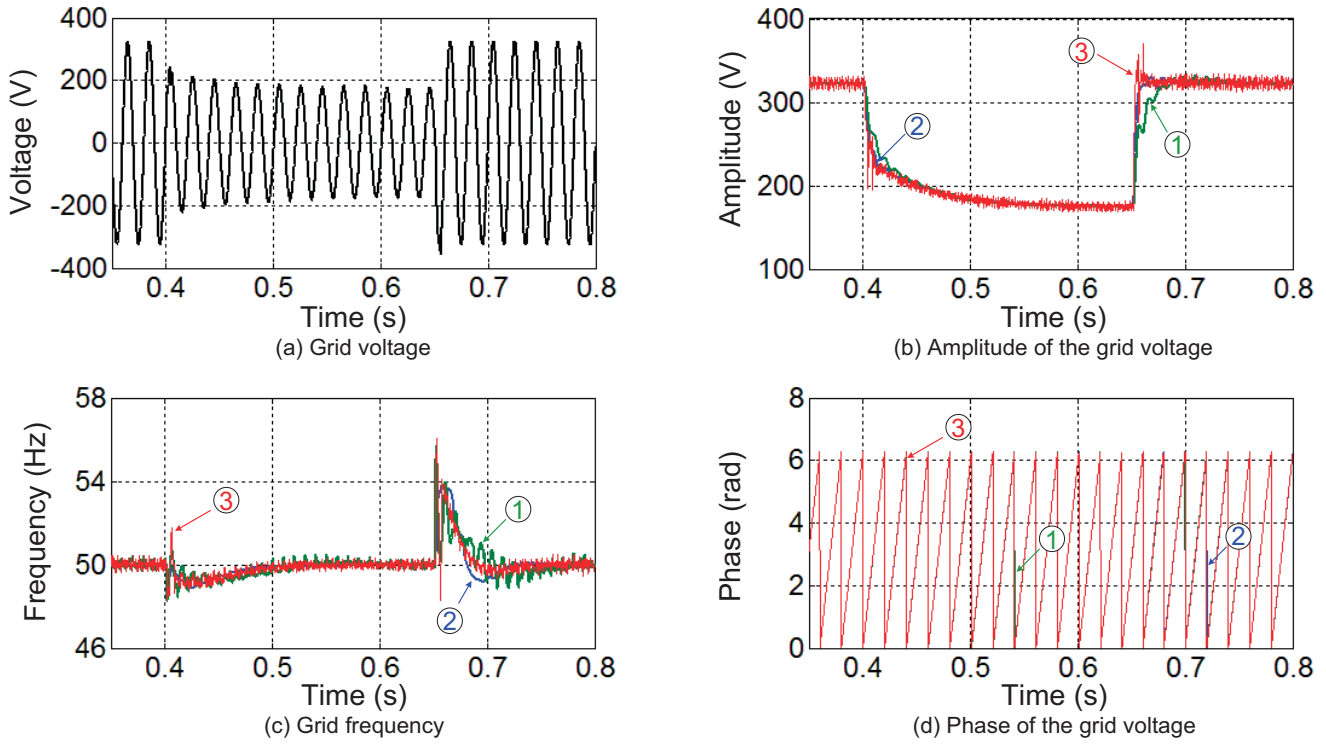

Fig. 13. Comparison of the three selected PLLs under a grid voltage sag (0.45 p.u.) by simulations:  
 1. Enhanced PLL; 2. Second-Order Generalized Integrator based PLL; 3. T/4 Delay based PLL.

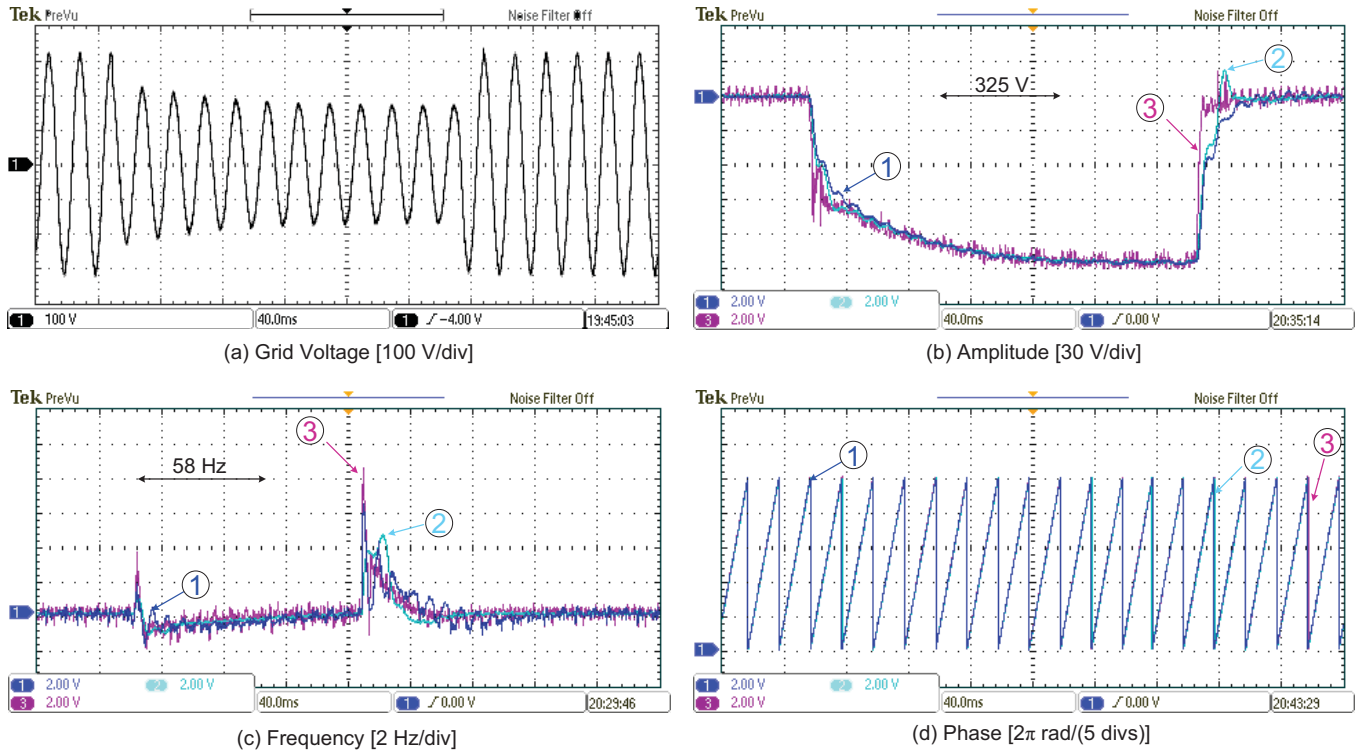

Fig. 14. Experimental results of the three selected PLLs under a grid voltage sag (0.45 p.u.):  
 1. Enhanced PLL; 2. Second-Order Generalized Integrator based PLL; 3. T/4 Delay based PLL, [ $t = 40$  ms/div].



A 0.45 p.u. voltage sag is generated by switching the resistors  $R_s$  and  $R_L$  as shown in Fig. 12. During the fault, the system is controlled to limit the active power output without tripping the current protection. Thus, the reliability of the PV inverter is improved. Practically, the active power could be controlled by regulating the maximum power point. In the LVRT operation mode, the reactive power is injected into the utility grid until the grid voltage recovers to 0.9 p.u., as it is required in the grid codes. From Fig. 15 and Fig. 16, it is concluded that the single-phase system can provide reactive power according to the depth of the voltage sag in such a way to support the grid and protect the customers' equipment, and it can do it fast. After the clearance of the voltage fault, the grid current and the output active power go back to their normal values.

Since the SOGI-OSG PLL is also used to detect the voltage sag, the transient behavior is not good as it is shown in Fig. 16. Thus, it is necessary to develop a specific fast sag detection algorithm in order to guarantee a better performance of single-phase PV systems under grid faults.

## VI. CONCLUSIONS

This paper presents the future requirements for single-phase grid-connected PV systems at a high penetration level under grid faults. It can be concluded that the future grid-connected PV systems will be more active and more "smart", which means the future grid-connected PV systems should have some ancillary functionalities as the conventional power plants do in the presence of an abnormal grid condition.

Different control strategies of such kind of single-phase PV systems under grid faults are discussed and it is concluded that the control possibilities play an important role in single-phase applications, since they are responsible not only for the power quality and protection issues but also for the upcoming ancillary requirements. It can also be concluded that the single-phase PV inverters are ready to provide grid support considering a high-level penetration. Selected detection and synchronization techniques are also compared in the case of grid fault conditions. The comparison demonstrates that the SOGI-OSG based PLL technique might be the promising candidate for single-phase systems under grid faults. Furthermore, another adaptive filtering based PLL (EPLL) shows also a good performance under voltage sag, but it has transient variations. However, the concept of EPLL leads to the possibility of direct instantaneous power control for single-phase systems.

A single-phase case is studied and tested experimentally at the end of this paper in order to demonstrate the overall system performance under grid faulty conditions and it shows satisfactory performance.

## ACKNOWLEDGEMENT

The authors would like to thank Dr. Huai Wang from the Department of Energy Technology, Aalborg University for his valuable advice and the discussions.

## REFERENCES

- [1] "EPIA-Market Report, 2011," EPIA, Tech. Rep., Jan. 2012. [Online]. Available: <http://www.epia.org/>
- [2] M. Braun, T. Stetz, R. Brundlinger, C. Mayr, K. Ogimoto, H. Hatta, H. Kobayashi, B. Kroposki, B. Mather, M. Coddington, K. Lynn, G. Graditi, A. Woyte, and I. MacGill, "Is the distribution grid ready to accept large-scale photovoltaic deployment? State of the art, progress, and future prospects," *Progress in Photovoltaics: Research and Applications*, vol. 20, no. 6, pp. 681-697, 2012.
- [3] IEEE Standard Committee, "IEEE Application Guide for IEEE Std 1547, IEEE Standard for Interconnecting Distributed Resources with Electric Power Systems", *IEEE Std 1547. 2-2008*, pp. 1-207, 2009.
- [4] F. Iov, A. D. Hansen, P. E. Sørensen, and N. A. Cutululis, "Mapping of grid faults and grid codes," Risø National Laboratory, Technical University of Denmark, Tech. Rep., 2007.
- [5] E. ON GmbH, "Grid Code - High and Extra High Voltage." [Online]. Available: <http://www.eon-netz.com/>
- [6] R. Teodorescu, M. Liserre, and P. Rodriguez, *Grid Converters for Photovoltaic and Wind Power Systems*. John Wiley & Sons, 2011.
- [7] F. Blaabjerg, M. Liserre, and K. Ma, "Power electronics converters for wind turbine," *IEEE Trans. Ind. Appl.*, vol. 48, no. 2, pp. 708-719, Mar.-Apr. 2012.
- [8] F. Blaabjerg, R. Teodorescu, M. Liserre, and A. Timbus, "Overview of control and grid synchronization for distributed power generation systems," *IEEE Trans. Ind. Electron.*, vol. 53, no. 5, pp. 1398-1409, Oct. 2006.
- [9] S. B. Kjaer, J. K. Pedersen, and F. Blaabjerg, "A review of single-phase grid-connected inverters for photovoltaic modules," *IEEE Trans. Ind. Appl.*, vol. 41, no. 5, pp. 1292-1306, Sept.-Oct. 2005.
- [10] E. J. Coster, J. M. A. Myrzik, B. Kruimer, and W. L. Kling, "Integration issues of distributed generation in distribution grids," *Proceedings of the IEEE*, vol. 99, no. 1, pp. 28-39, Jan. 2011.
- [11] G. M. S. Islam, A. Al-Durra, S. M. Mueyeen, and J. Tamura, "Low voltage ride through capability enhancement of grid connected large scale photovoltaic system," in *Proc. of IECON'11*, pp. 884-889, Nov. 2011.
- [12] M. Braun, G. Arnold, and H. Laukamp, "Plugging into the zeitgeist," *IEEE Power Energy Mag.*, vol. 7, no. 3, pp. 63-76, 2009.
- [13] H. Alatrash, R.A. Amarin, and L. Cheung, "Enabling Large-Scale PV Integration into the Grid," in *Proc. of 2012 IEEE Green Technologies Conference*, pp.1-6, 19-20 April 2012.
- [14] R. Hudson and G. Heilscher, "PV grid integration—system management issues and utility concerns," *Energy Procedia*, vol. 25, pp. 82-92, 2012.
- [15] M.H. Coddington, B.D. Kroposki, and T.S. Basso, "Evaluating future standards and codes with a focus on high penetration photovoltaic (HPPV) system deployment," in *Proc. of IEEE PVSC*, pp. 544-549, 20-25 June 2010.
- [16] Comitato Elettrotecnico Italiano, "CEI 0-21: Reference technical rules for connecting users to the active and passive LV distribution companies of electricity," [Online]. Available: <http://www.ceiweb.it/>
- [17] C. H. Benz, W. Franke, and F. W. Fuchs, "Low voltage ride through capability of a 5 kW grid-tied solar inverter," in *Proc. of EPE/PEMC*, pp. T12-13-T12-20, Sept. 2010.
- [18] K. Fujii, N. Kanao, T. Yamada, and Y. Okuma, "Fault ride through capability for solar inverters," in *Proc. of EPE/PEMC*, pp. 1-9, 2011.
- [19] H. Kobayashi, "Fault ride through requirements and measures of distributed PV systems in Japan," in *Proc. of IEEE-PES General Meeting*, pp.1-6, 22-26 July 2012.
- [20] A. Marinopoulos, F. Papandrea, M. Reza, S. Norrga, F. Spertino, and R. Napoli, "Grid integration aspects of large solar PV installations: LVRT capability and reactive power/voltage support requirements," in *Proc. of IEEE Trondheim PowerTech*, pp. 1-8, June 2011.
- [21] C. Photong, C. Klumpner, and P. Wheeler, "A current source inverter with series connected AC capacitors for photovoltaic application with grid fault ride through capability," in *Proc. of IECON'09*, pp. 390-396, Nov. 2009.
- [22] M. Saitou and T. Shimizu, "Generalized theory of instantaneous active and reactive powers in single-phase circuits based on hilbert transform," in *Proc. of PESC'02*, vol. 3, pp. 1419-1424, 2002.

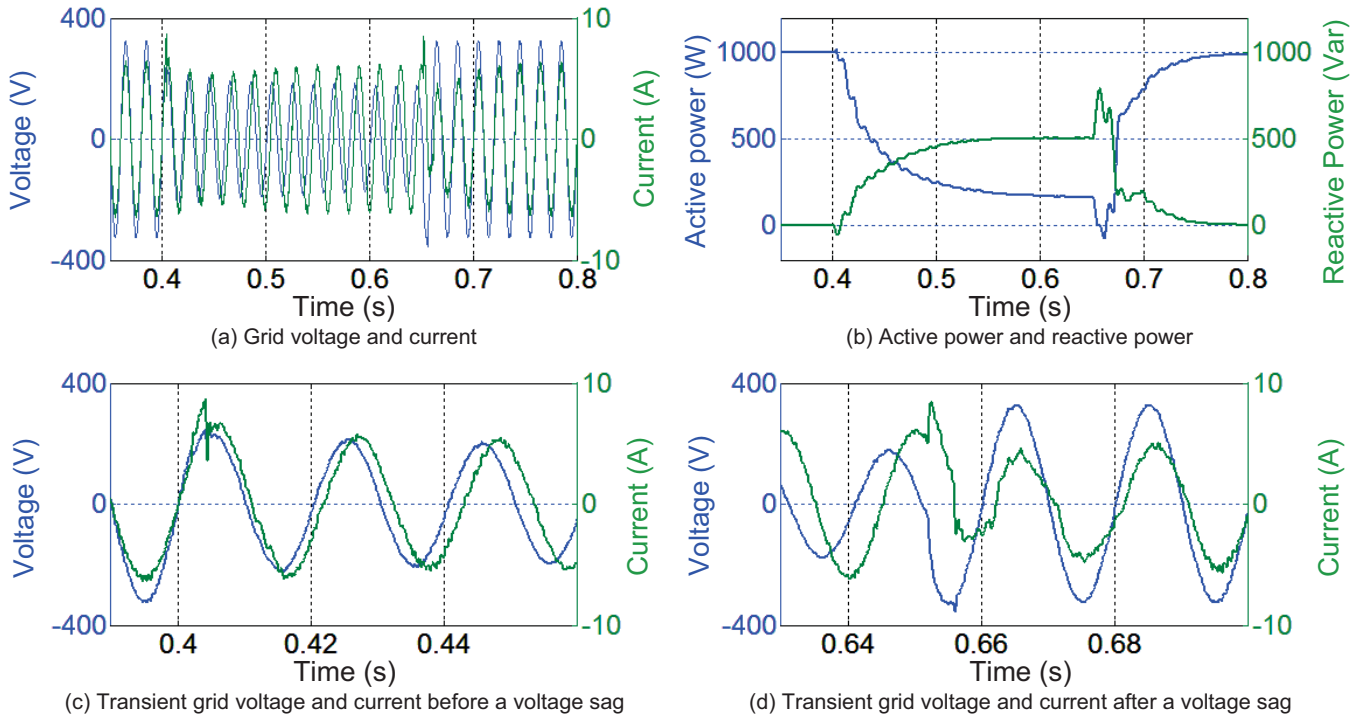

Fig. 15. Simulation results of a single-phase grid-connected system under voltage sag (0.45 p.u.) using PR controller and SOGI-OSG PLL synchronization method.

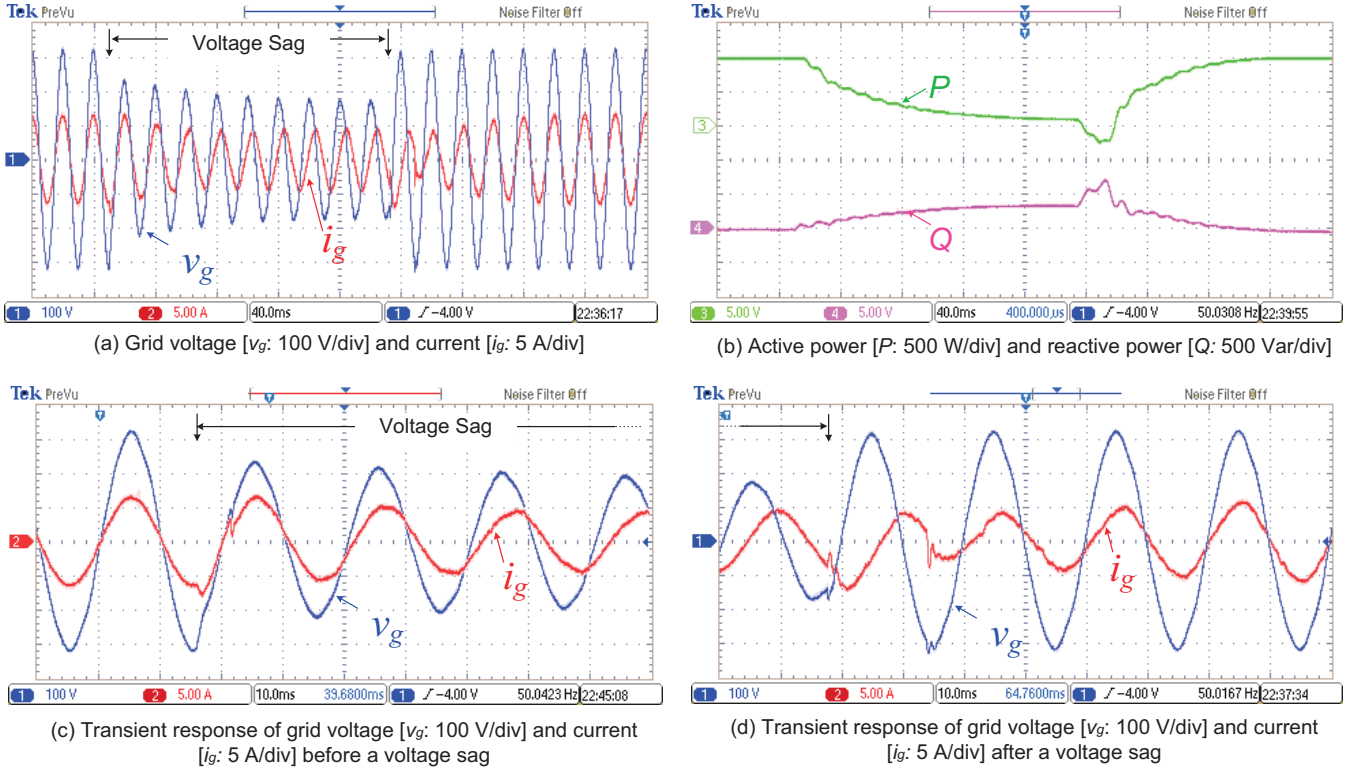

Fig. 16. Experimental results of a single-phase grid-connected system under voltage sag (0.45 p.u.) using PR controller and SOGI-OSG PLL synchronization method, [ $t = 40$  ms/div].

- [23] M. Prodanovic, K. De Brabandere, J. Van Den Keybus, T. Green, and J. Driesen, "Harmonic and reactive power compensation as ancillary services in inverter-based distributed generation," *IET Gener. Transm. Distrib.*, vol. 1, no. 3, pp. 432–438, May 2007.
- [24] R. A. Mastromauro, M. Liserre, T. Kerekes, and A. Dell'Aquila, "A single-phase voltage-controlled grid-connected photovoltaic system with power quality conditioner functionality," *IEEE Trans. Ind. Electron.*, vol. 56, no. 11, pp. 4436–4444, Nov. 2009.
- [25] J. C. Vasquez, R. A. Mastromauro, J. M. Guerrero, and M. Liserre, "Voltage support provided by a droop-controlled multifunctional inverter," *IEEE Trans. Ind. Electron.*, vol. 56, no. 11, pp. 4510–4519, Nov. 2009.
- [26] R. M. Santos Filho, P. F. Seixas, P. C. Cortizo, L. A. B. Torres, and A. F. Souza, "Comparison of three single-phase PLL algorithms for UPS applications," *IEEE Trans. Ind. Electron.*, vol. 55, no. 8, pp. 2923–2932, Aug. 2008.
- [27] A. Nicastrì and A. Nagliero, "Comparison and evaluation of the PLL techniques for the design of the grid-connected inverter systems," in *Proc. of ISIE'10*, pp. 3865–3870, July 2010.
- [28] A. Nagliero, R. A. Mastromauro, M. Liserre, and A. Dell'Aquila, "Monitoring and synchronization techniques for single-phase PV systems," in *Proc. of SPEEDAM*, pp. 1404–1409, June 2010.
- [29] S. Golestan, M. Monfared, F. Freijedo, and J. Guerrero, "Design and tuning of a modified power-based PLL for single-phase grid-connected power conditioning systems," *IEEE Trans. Power Electron.*, vol. 27, no. 8, pp. 3639–3650, Aug. 2012.
- [30] L. N. Arruda, S. M. Silva, and B. J. C. Filho, "PLL structures for utility connected systems," in *Proc. of IEEE-IAS Annu. Meeting*, vol. 4, pp. 2655–2660, 2001.
- [31] M. K. Ghartemani, S. A. Khajehoddin, P. K. Jain, and A. Bakhshai, "Problems of startup and phase jumps in PLL systems," *IEEE Trans. Power Electron.*, vol. 27, no. 4, pp. 1830–1838, Apr. 2012.
- [32] P. Rodriguez, A. Luna, R. Munoz-Aguilar, F. Corcoles, R. Teodorescu, and F. Blaabjerg, "Control of power converters in distributed generation applications under grid fault conditions," in *Proc. of IEEE ECCE'11*, pp. 2649–2656, Sept. 2011.
- [33] B. Bahrani, A. Rufier, S. Kenzelmann, and L. A. C. Lopes, "Vector control of single-phase voltage-source converters based on fictive-axis emulation," *IEEE Trans. Ind. Appl.*, vol. 47, no. 2, pp. 831–840, Mar.-Apr. 2011.
- [34] S. A. Khajehoddin, M. Karimi Ghartemani, A. Bakhshai, and P. Jain, "A power control method with simple structure and fast dynamic response for single-phase grid-connected DG systems," *IEEE Trans. Power Electron.*, vol. 28, no. 1, pp. 221–233, Jan. 2013.
- [35] M. Karimi-Ghartemani and M. R. Iravani, "A new phase-locked loop (PLL) system," in *Proc. of IEEE MWSCAS*, vol. 1, pp. 421–424, 2001.
- [36] P. S.R. Diniz, *Adaptive Filtering: Algorithms and Practical Implementation*. Springer, 2010.
- [37] M. Ciobotaru, R. Teodorescu, and F. Blaabjerg, "A new single-phase PLL structure based on second order generalized integrator," in *Proc. of PESC'06*, pp. 1–6, June 2006.
- [38] S. Douglas and T.-Y. Meng, "A nonlinear error adaptive notch filter for separating two sinusoidal signals," in *Proc. of ASILOMAR*, vol. 2, pp. 673–677, Nov. 1991.
- [39] X. Yuan, W. Merk, H. Stemmler, and J. Allmeling, "Stationary-frame generalized integrators for current control of active power filters with zero steady-state error for current harmonics of concern under unbalanced and distorted operating conditions," *IEEE Trans. Ind. Appl.*, vol. 38, no. 2, pp. 523–532, Mar./Apr. 2002.
- [40] A. Camacho, M. Castilla, J. Miret, J. Vasquez, and E. Alarcon-Gallo, "Flexible voltage support control for three phase distributed generation inverters under grid fault," *IEEE Trans. Ind. Electron.*, Early Access, 2013.
- [41] S. M. Silva, B. M. Lopes, B. J. C. Filho, R. P. Campana, and W. C. Bosventura, "Performance evaluation of PLL algorithms for single-phase grid-connected systems," in *Proc. of IEEE-IAS Annu. Meeting*, vol. 4, pp. 2259–2263, Oct. 2004.
- [42] M. Z. C. Wanik, A. Mohamed, A. F. A. Kadir, and I. Erlich, "Low voltage ride through capability of fuel cell generation system connected to low voltage network," in *Proc. of IEEE CET*, pp. 369–373, June 2011.
- [43] M. Bollen, *Understanding power quality problems: voltage sags and interruptions*. IEEE Press, 2000.
- [44] Y. Yang and F. Blaabjerg, "Synchronization in single-phase grid-connected photovoltaic systems under grid faults," in *Proc. of PEDG'12*, pp. 476–482, Aalborg 25–28 June 2012.
- [45] J. Miret, M. Castilla, A. Camacho, L. Garcia de Vicuña, and J. Matas, "Control scheme for photovoltaic three-phase inverters to minimize peak currents during unbalanced grid-voltage sags," *IEEE Trans. Power Electron.*, vol. 27, no. 10, pp. 4262–4271, Oct. 2012.
- [46] R. Yan and T.K. Saha, "Investigation of voltage stability for residential customers due to high photovoltaic penetrations," *IEEE Trans. Power Syst.*, vol. 27, no. 2, pp. 651–662, May 2012.