



Review of modular power converters solutions for smart transformer in distribution system

Alzola, Rafael Pena; Gohil, Ghanshyamsinh Vijaysinh; Mathe, Laszlo; Liserre, Marco; Blaabjerg, Frede

Published in:

Proceedings of the IEEE Energy Conversion Congress and Exposition

DOI (link to publication from Publisher):

[10.1109/ECCE.2013.6646726](https://doi.org/10.1109/ECCE.2013.6646726)

Publication date:

2013

Document Version

Early version, also known as pre-print

[Link to publication from Aalborg University](#)

Citation for published version (APA):

Alzola, R. P., Gohil, G. V., Mathe, L., Liserre, M., & Blaabjerg, F. (2013). Review of modular power converters solutions for smart transformer in distribution system. In *Proceedings of the IEEE Energy Conversion Congress and Exposition: ECCE 2013* (pp. 380-387). IEEE Press. <https://doi.org/10.1109/ECCE.2013.6646726>

General rights

Copyright and moral rights for the publications made accessible in the public portal are retained by the authors and/or other copyright owners and it is a condition of accessing publications that users recognise and abide by the legal requirements associated with these rights.

- Users may download and print one copy of any publication from the public portal for the purpose of private study or research.
- You may not further distribute the material or use it for any profit-making activity or commercial gain
- You may freely distribute the URL identifying the publication in the public portal -

Take down policy

If you believe that this document breaches copyright please contact us at vbn@aub.aau.dk providing details, and we will remove access to the work immediately and investigate your claim.

Review of Modular Power Converters Solutions for Smart Transformer in Distribution System

Rafael Peña-Alzola, Ghanshyamsinh Gohil, Laszlo Mathe, Marco Liserre, Frede Blaabjerg

Department of Energy Technology

Aalborg University

Denmark

rpa@et.aau.dk, gvg@et.aau.dk, lam@et.aau.dk, mli@et.aau.dk, fbl@et.aau.dk,

Abstract—While the use of power electronics based Smart Transformer (ST) is becoming a reality in traction applications, and it has been considered as an interesting option for interfacing different transmission systems, the possibility to use it in distribution systems is still considered futuristic. Replacing primary distribution transformers with ST can lead to more flexible handling of the distribution feeders, while replacing secondary distribution transformers can allow decoupling of distribution network. This paper reviews different power converter solutions for the ST focusing on modularity, control and communication needs, to meet high reliability requirements. Five topologies for the ST are considered and compared.

I. INTRODUCTION

Many interesting ideas have been proposed to redesign the electrical grid considering high penetration of renewable-energy and the consequent stringent constraints in terms of reliability and stability. All of them are characterized by the need of:

- 1) Upgrading the distribution network to make it active, allowing bidirectional power flow
- 2) Accounting storage systems and their interaction with other energy infrastructures to balance production and consumption
- 3) Embedding communication systems in the distribution network to make it smart and intelligent

Additionally it is foreseen that the electric mobility, whose batteries re-charging could pose a challenge to the distribution grid, can offer an opportunity in term of mobile energy storage to face the challenges associated with increased penetration of stochastic energy sources, such as wind and solar.

The ST can also help to overcome several issues associated with distribution network, which are difficult to deal with conventional off-load and on-load tap changer transformer, realizing the goal of smart, efficient and reliable distribution network. Some of the attributes of smart transformers are summarized below:

- Reduction in grid losses: The flow of active and reactive current in the grid causes resistive losses. The ST can supply the load reactive power locally. With less reactive power circulation in the grid, the transmission efficiency improves.
- Improved power quality: The presence of non linear load in the distribution network distorts voltage waveform

and results into voltage harmonics. Transformer saturation, could also add-up to the problem. In addition, balancing the distribution loads is impossible in practice and introduces voltage unbalance. The presence of wind energy generator/PVs (tower shadow/cloud passing) and large intermittent loads in a low voltage grid introduces voltage fluctuations. The low voltage side of ST is fully regulated and provides sinusoidal waveforms under non-linear loads. There are no core saturation effects in the ST as the high frequency transformer is isolated from the AC stages by the DC-links. In addition, harmonics generated by the non-linear loads are not propagated to rest of the system. Due to the presence of DC links, primary and secondary sides of the ST are completely decoupled and the load imbalance is not transmitted to grid. The fast control due to the use of power electronics converters allows fast voltage control to compensate power production variations that otherwise would result in flickers. ST can help in resolving flicker problems by making use of the stored energy in DC link capacitors or, if not sufficient, energy storage systems can be employed.

- Supply reliability: The ST can increase the service continuity by supplying loads during distribution outages or faults, by means of energy storage systems (EV batteries, short time flywheels, etc.) disregarding the disturbances from the distribution system.

The ST has to have some intelligence to meet the requirement of future power systems. A possible idea of ST, based on power electronics and communication technology is depicted in Fig. 1. The interaction of the ST with the distribution system is depicted in Fig. 2. Several projects focusing on designing a solid-state transformer, mainly for traction application [1], for interfacing different transmission systems [2] and for replacing primary distribution transformers [3] have been reported.

One of the main requirements of the secondary distribution transformer is the reliability that can be increased by selecting a fault tolerant design and by using redundancy. A modular approach can reduce the manufacturing cost and increase the availability by reducing the mean time to repair [1].

The aim of this paper is to compare different power elec-

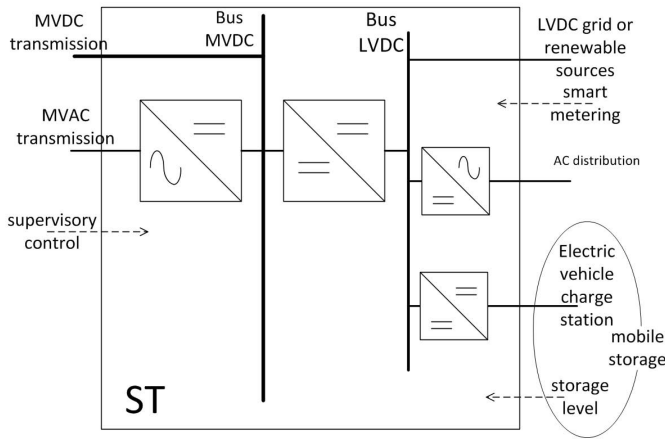

Fig. 1. Smart Transformer concept.

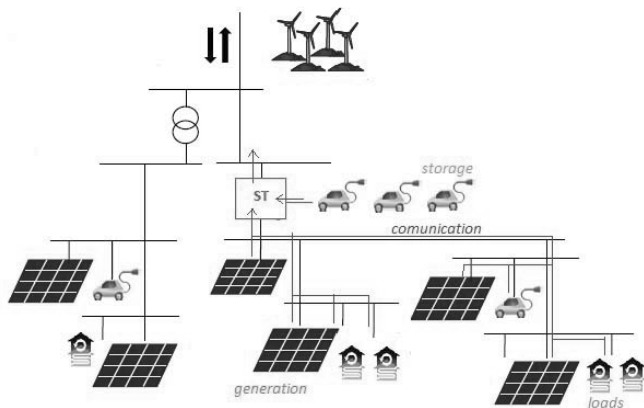

Fig. 2. The role of the Smart Transformer in the distribution grid.

tronics solutions for the ST in view of modularity, hardware, control and communication requirements. The paper is organized as follows: Section II describes the possible modular architectures for the ST, Section III review different power converter cells for ST, section IV studies the modular connection of cell, section V describes control and communication and finally section VI compares different cases considered in this study.

II. ST ARCHITECTURE

In the choice of the architecture of an ST, the system level goals shall be taken into account. In distribution system the main problem is the cumulative impact of distributed generation (solar and wind) and high power domestic loads. It is expected that the ST should:

- Protect the power system from load disturbances and vice versa by isolating source and load harmonics, transients and voltage sags
- Enhance the power quality by symmetrizing the loads to the mains with identical phase currents even for unbalanced loads, providing unity power factor with sinusoidal currents under non-linear loads

- Coordinate fault re-closing over sub-grids zones when connecting to other STs
- Accept direct connection to future MVDC power transmission, low voltage DC grid, storage systems and renewable energy systems

Some of the previous features depend on the ST architecture namely on the number of stages [4] and on the output type as it is explained in the following.

A. One-state or two-stage

Converter architecture consisting in only one stage performing direct AC/AC conversion [5], even inexpensive and reliable due to the reduced component number, it does not allow any interaction with DC grid, DC transmission, local storage and local renewable sources. In addition, with this configuration the disturbances on one side may also affect the other side as happens with traditional transformers. The approach using two stages with AC/DC conversion in the MV-side, and DC/AC conversion in the LV-side, results in elevated losses as it is difficult to obtain zero voltage switching (ZVS) [5].

B. Three-stages

The configuration shown in Fig. 3 with DC-links in both sides and performing three stages of conversion (AC/DC in the MV-side, isolated DC/DC conversion and finally AC/DC in the LV-side) is the most preferred architecture of ST for distribution systems. This architecture allows all the previously mentioned features and is the one adopted by the main projects developing a ST for distribution namely the UNIFLEX [3], EPRI [6], GE [7], and FREEDM [2]. One degree of freedom is given by the use of a three phase converter, see Fig. 3a, or using three single phase converters, Fig. 3b, just like a three phase transformer can be constructed using a three phase core or using three single phase transformers. The use of the single phase converters bears the problem related to the power pulsation at twice the grid frequency. Notwithstanding, this approach allows increased modularity and eases N+1 redundancy.

A combined approach can also be used as shown in Fig. 4 with only independent phases in the MV-side. From the review of ST architecture solutions it emerges that the three-stage topology, of which core is an isolated DC/DC converter, is the most feasible and it will be used as main architecture in the following.

III. POWER CONVERTERS CELLS FOR ST

Once chosen the ST architecture, the next step is choosing which should be the basic brick of the ST, the power converter cell. The goals are achieving isolation for the different voltage level with reduced core size and minimal losses. For this aim power converters should commute at high frequency and to reduce losses soft switching techniques are needed. The high frequency waveforms produce elevated eddy current losses, approximately proportional to the squared frequency, and hysteresis losses, approximately proportional to the frequency, in the core material. Therefore, only core materials producing

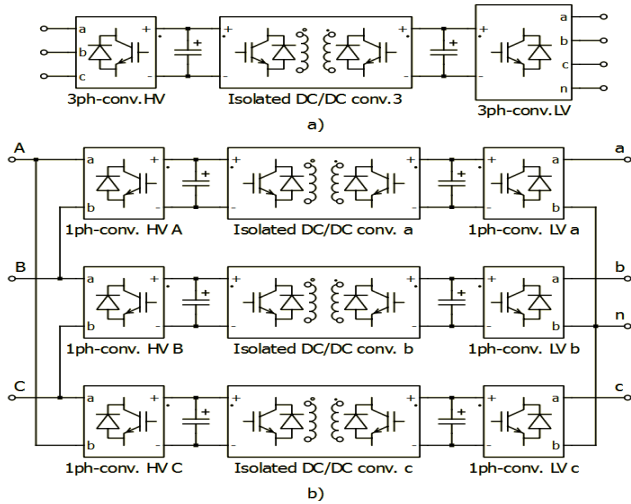

Fig. 3. Different approaches to construct the three phase ST by using , a) three phase and, b) single phase converters.

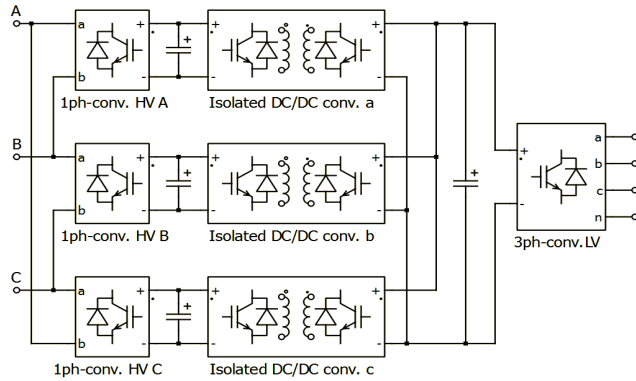

Fig. 4. Combined approach to construct the three phase ST by using three phase and single phase converters.

very low losses, such as amorphous (metglas, vitrovac) or nanocrystalline (finemet, vitroperm) are admissible for the ST applications [2].

A. Single-phase dual active bridge

The dual active bridge (DAB), see Fig. 5 [8] is the keystone of the isolated DC-DC converter for ST applications. The unidirectional version of the DAB has diodes instead of power switches in the LV-side [8]. The simplest control for the DAB consists in each converter producing square wave voltages and varying the phase shift between them. Considering the first harmonic only, this can be assimilated to two sinusoidal voltage sources connected to an inductor, which represents the transformer leakage inductance. The zero voltage switching occurs naturally for the full power range only when the ratio of DC-voltages is unity, for the other cases advanced modulation scheme guarantees soft-switching for the MV-side [8]. The inequalities in the power devices characteristics (on resistance, voltage drop, turn on and turn off durations)

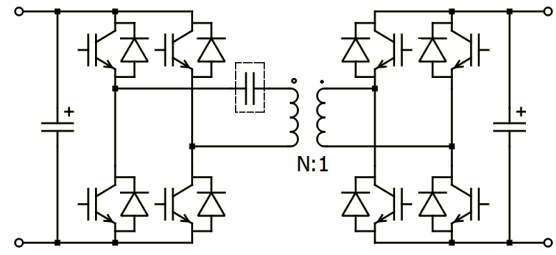

Fig. 5. Dual active bridge: single phase case, a), its model, b), series capacitor for SR-DAB is shown dashed.

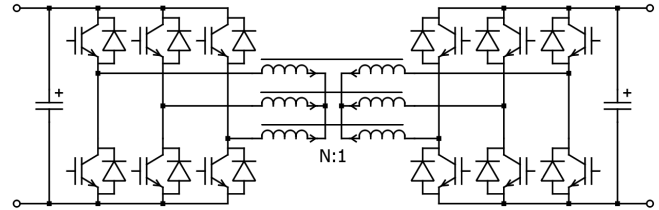

Fig. 6. Three phase dual active bridge.

due to manufacturing tolerances may result in a net DC bias current that saturate the transformer. To prevent this dangerous situation air gap cores [9] can be used at the expense of additional losses or the DC bias current can be canceled, by means of an auxiliary small converter, after measuring the flux with a magnetic transducer [10].

B. Three-phase dual active bridge

The three phase DAB, see Fig. 6, results in lower device stress, better transformer utilization and lower filter requirements. However, the three phase transformer requiring symmetrical leakage inductances [8] results more complex to manufacture and additional power devices are necessary.

C. Series resonant DAB

If a capacitor is inserted in series with transformer, shown dashed in Fig. 5a, the series resonant DAB (SR-DAB) is obtained. This configuration is inherently protected against the transformer saturation and allows reduced RMS transformer currents and switching losses. As disadvantages the control is more complex and the required capacitor is subject to large current variations [11].

D. Other DAB configurations using half bridges or NPC

To reduce the number of power devices, half bridges can be used. To achieve larger voltages the high side bridge can make use of the NPC configuration which is also useful for reducing switching losses [11].

IV. MODULAR CONNECTION OF CELLS

Reliability is the first concern, in fact in case of failure, apart from the revenue loss, multiple complains by users can be expected. A modular approach can make the ST design robust and fault-tolerant [1]. The overall system should be able

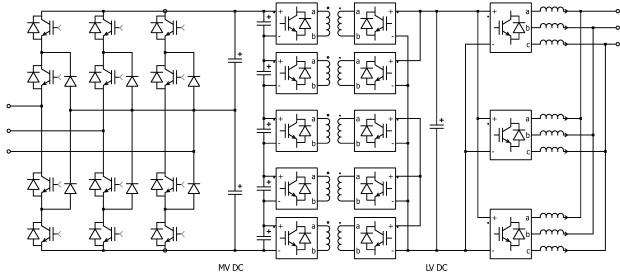

Fig. 7. SST with available MVDC-link as Case 3

to work even with faulty modules. This feature could also be harnessed to increase efficiency by disconnecting modules, and so canceling their losses, during partial loading conditions.

A. Modular connection to share voltage in the MV-side.

Two options are possible: using a single medium voltage power converter, like NPC see Fig. 7, or connecting cells such as H-bridges or half bridges in series, see Fig. 8. In case of MVDC-link is made available, the future connection with MVDC transmission can be feasible.

B. Modular connection to share current in the LV-side.

The LV-side allows using simple two level converters: H-bridges or three phase converters. Parallel power converters may be necessary due to the limited capability for current handling of the most adopted power modules. Three options are possible and they will be reviewed in the following.

1) *Independent DC-links or common DC-links.*: All the LV-sides of the isolated DC-DC converters can be connected together to a common DC-link as shown in Fig. 7. This scheme allows easier balancing of the power flow between the different phases in MV-side. In addition, interleaving the isolated DC-DC converters may help to reduce the ripple in the DC-link capacitor. The parallel converters sharing the common DC-link need CM chokes for reduction of the circulating currents. Moreover, the DC-link capacitor becomes a critical component as all the power flows circulate through it. Conversely, Fig. 9 uses separated DC-links at the output of the isolated DC-DC converters. To ease the power flow balance between the different phases of the MV-side the magnetic coupling of the isolated DC-DC converters is shared between the different phases, see Fig. 10. On the other hand, power flow in separated DC-links allows disconnection for repairs of only the faulty modules and so increasing availability.

2) *Single phase and three phase inverters.*: Single phase converters and three phase converters can be used. Single phase converters results in higher modularity as all the LV-side power converters have similar rating and characteristics. It must be reckoned that there will be single phase loads along with three phase loads (typically from motors) connected to the ST for distribution.

3) *Magnetic parallel connection*: The proposal stated in [12] increases the ST modularity by substituting the three-phase inverter for three H-bridges in the three phase dual

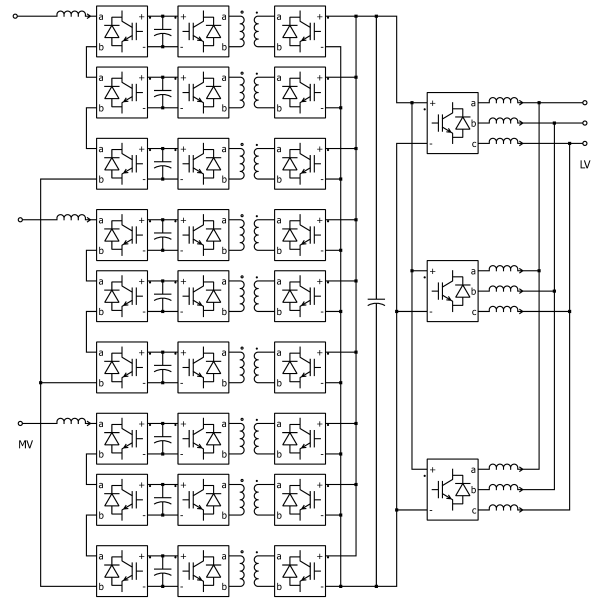

Fig. 8. SST with LV-side converters sharing a common DC-link as case 4

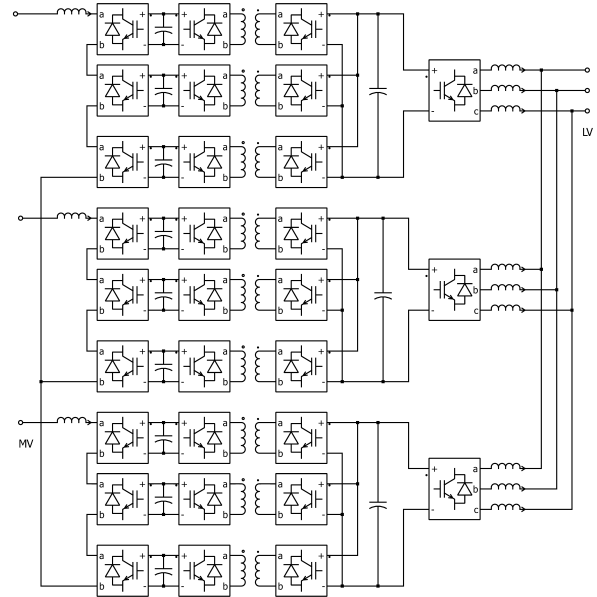

Fig. 9. SST with LV-side converters with independent DC-links as case 5

active bridge. H-bridges and three phase inverters are used for series and parallel connection in the ac MV-side and LV-side respectively.

V. CONTROL AND COMMUNICATION OF MODULAR STRUCTURES

The modular structure of the ST pose the following challenges: circulating currents, DC-link balancing and active-reactive power control. Several modulation strategies have been proposed for modular converters. The control can be

TABLE I

PROFINET	16 bytes-650s	36 bytes-650s	100 bytes-1250s
EtherCAT	16 bytes-250s	36 bytes-400s	100 bytes-1250s

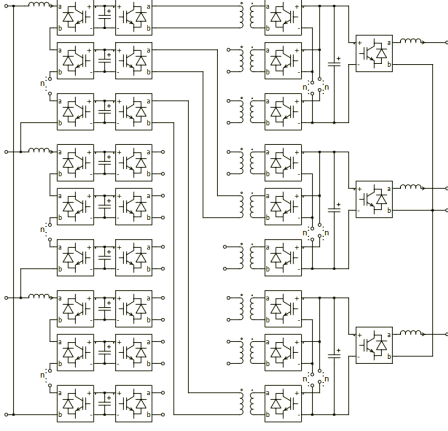

Fig. 10. SST with magnetic coupling between different phases

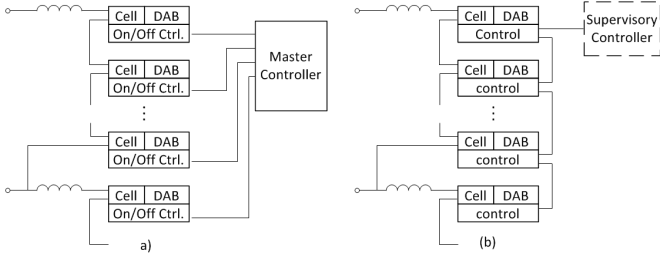

Fig. 11. Different control strategies for modular structures: centralized control, a), decentralized control, b).

centralized, decentralized or a hybrid solution can be adopted. In the centralized control a master controller calculates the on-off state of the switches 11a. This structure requires a high bandwidth for communication to transmit the time critical control signals. In the decentralized control each module is equipped with its own sensors, controller and modulator, in this way each module can operate independently like is shown in 11b. The design of such a decentralized control is more cumbersome. The hybrid control method is a combination between the centralized and decentralized method where the overall system control loop, such as active-reactive power control, is done by a master controller and the sub-modules are dealing with the local control such as modulation, DC-link balancing.

By having a large number of modules in such a transformer, the communication in-between the modules and the master controller becomes an important issue. In the centralized control a solution is to send the modulation signals separately to each module. However, due to the high number of modules this solution requires a high number of wires which makes

it very inefficient. Another solution is to use industrial communication protocols, such as CAN, PROFINET, EtherCat, etc., to transmit the on-off states or the reference voltages [13]. Real time communication is an important requirement because long communication delays affect the modulation, especially in the centralized control structure. Anyway, a precise synchronization between the modules has to be also ensured. CAN bus was successfully used to control multilevel inverters [14], however its maximum baud rate of 1Mbit/s makes it inferior compared to PROFINET or EtherCat (100Mbit/s-1Gbit/s). In Table I, the results of a study made in [15] is presented where a comparison between the data transfers of EtherCat and PROFINET is presented for a slave device chain of 100 modules where each slave has a payload of 16-36-100bytes (1.6-3.6-10kbit data transfer in total). Based on Table I it was concluded in [15] that the EtherCat uses less overhead per slave device especially in case when low amount of data is exchanged in-between the master and the slaves. EtherCat communication technology is suitable to control modular converter as it was similarly done in [16]. The time delay introduced by the communication in case of Ethercat it can be estimated with:

$$Com_{delay} = \frac{PL}{EC_{bw}}Oh + Sl_{Nr}EC_{Maxdelay} \quad (1)$$

where PL is the payload per device in bits, EC_{bw} is the bandwidth of the EtherCat, Oh is the overhead for the communication, Sl_{Nr} is the number of slave modules and $EC_{Maxdelay}$ is the maximum forwarding delay per device. Considering a case when 10 modules are placed in a leg the delay caused by communication, based on (1), would be $6\mu s$ where $Pl = 10bytes$, $EC_{bw} = 100Mbit/s$, $Oh = 10\%$, $Sl_{Nr} = 10$, $EC_{Maxdelay} = 0.5\mu s$. At this communication speed a new reference value can be easily sent for each modulation period, considering a switching frequency of 10kHz.

A strong feature of the EtherCat protocol is the accurate synchronization between the slave devices using its distributed clock, which gives the possibility to use distributed modulation strategies like phase shifted carrier PWM. Beside the high speed, when the communication protocol is chosen it has also to be considered the requirement for high voltage isolation, which can be solved by moving the communication from copper wires to optical wires. EtherCat supports communication redundancy, which can be made in order to avoid the faults like broken communication cable similarly as it was done in [16].

VI. COMPARISON

SiC IGBTs withstanding 12 kV have been reported in [17] albeit not readily available. As soon as they are in commercial

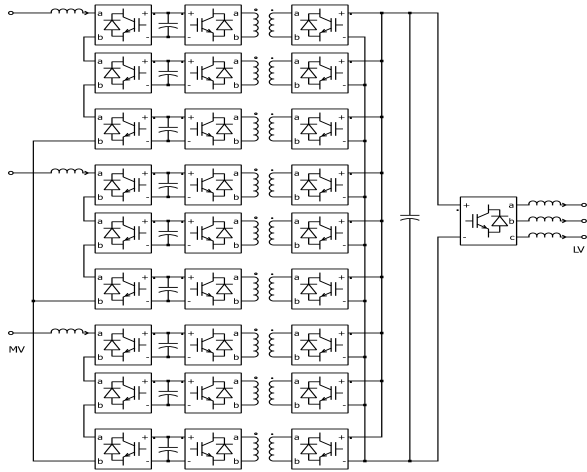

Fig. 13. Case 2: Topology

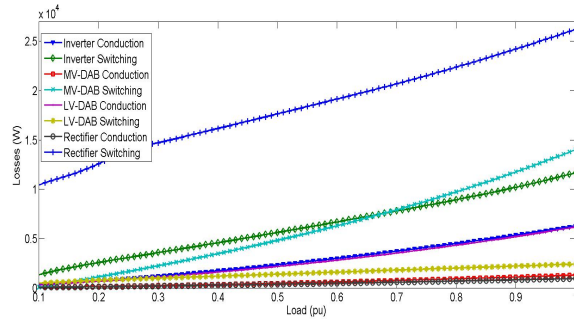

Fig. 14. Semiconductor Losses: Case 1

production it is foreseeable that they will play an important role in ST development [18]. The wide band gap devices allows higher switching frequency with lower losses than Si power devices at the expense of higher cost [19]. For this study commercial available Si devices have been considered to study the current potential. This is important, considering the steady improvement in efficiency at reasonable cost of Si devices in recent past [19]. In this section five topologies were compared, Table II describes the five cases considered and also refers to the corresponding figures.

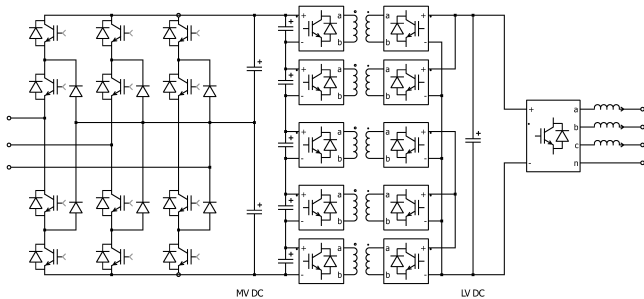

Fig. 12. Case 1: Topology

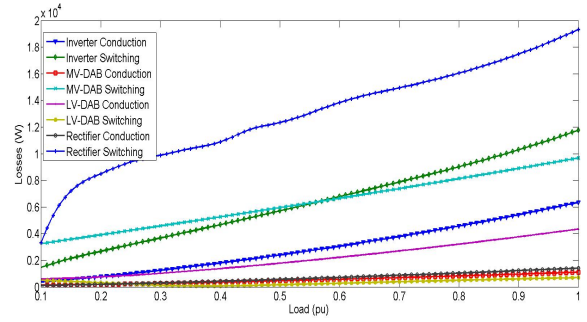

Fig. 15. Semiconductor Losses: Case 2

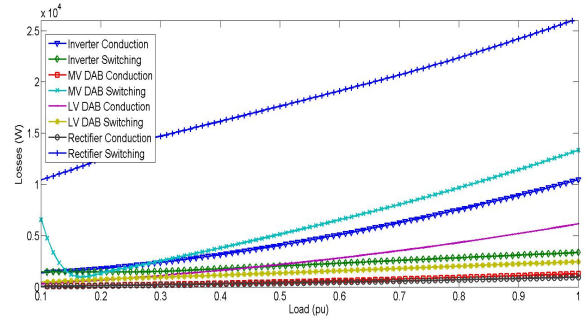

Fig. 16. Semiconductor Losses: Case 3

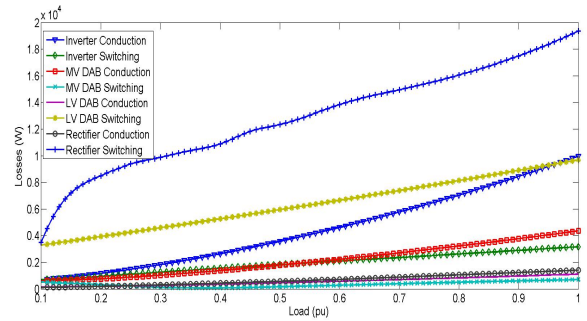

Fig. 17. Semiconductor Losses: Case 4

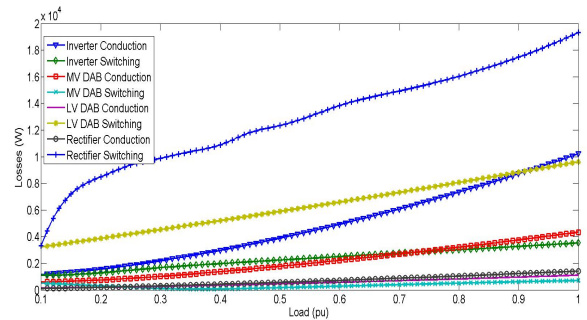

Fig. 18. Semiconductor Losses: Case 5

For all the cases the rated power is $S_{nom} = 1$ MVA and the rated frequency is $f_{nom} = 50$ Hz. The medium side voltage (ph-ph rms) is 11 kV and the low side voltage is 400 V.

TABLE II
PARAMETERS OF THE DIFFERENT SIMULATION CASES

Case	MV-side converter	MV f_{sw} Device rating	MVDC-link voltage	Isolation Stages	DAB f_{sw} Device rating MV and LV side	LVDC-link voltage	No. of LV-side converter	LV f_{sw} Device rating	No. of LVDC links	Topology
1	NPC	3 kHz 6.5 KV, 250 A	17.88 kV	5 DABs	2 kHz 6.5 KV, 250 A 1200V, 450 A	650 V	1	6 kHz 1200 V, 2400 A	1	Fig. 12
2	CHB	1 kHz 6.5 KV, 250 A	10.32 kV	9 DABs	1.1 kHz 6.5 KV, 250 A 1200V, 300 A	700 V	1	6 kHz 1200 V, 2400 A	1	Fig. 13
3	NPC	3 kHz 6.5 KV, 250 A	17.88 kV	5 DABs	2 kHz 6.5 KV, 250 A 1200V, 450 A	650 V	3	2 kHz 1200 V, 800 A	1	Fig. 7
4	CHB	1 kHz 6.5 KV, 250 A	10.32 kV	9 DABs	1.1 kHz 6.5 KV, 250 A 1200V, 300 A	700 V	3	2 kHz 1200 V, 800 A	1	Fig. 8
5	CHB	1 kHz 6.5 KV, 250 A	10.32 kV	9 DABs	1.1 kHz 6.5 KV, 250 A 1200V, 300 A	700 V	3	2 kHz 1200 V, 800 A	3	Fig. 9

TABLE III
COMPARISON BETWEEN DIFFERENT CASES

Case	Modularity	Efficiency	Reliability	Cost	DC connectivity
1	-	-	++	++	MV and LV
2	+	+	+	+	LV
3	+	-	++	++	MV and LV
4	++	++	+	+	LV
5	++	++	+	+	LV

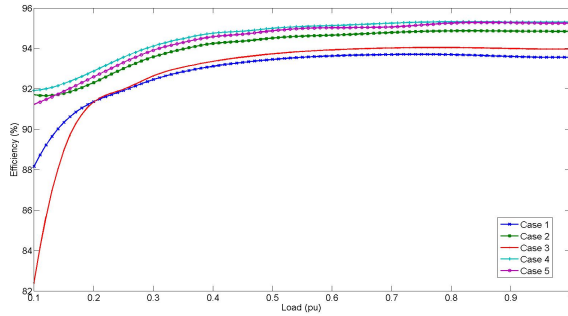

Fig. 19. Efficiency comparison

The NPC-converter has three levels and DC-link voltage was selected as 17.88 kV (15 % over the reverse diode voltage [20]). The 6.5 kV IGBTs has been selected for MV side NPC converter and two IGBTs are connected in series [21] to withstand the voltage. In all cases, the current rating of the 6.5 kV IGBTs is 250 A (FZ250R65KE3) [22], which gives enough margin for current handling. As the maximum current is 75 A the selected device has plenty of margin. The DABs consist single phase H-bridges using interleaved phase shift modulation. The number of DABs needed to accommodate the MVDC-level by using 6.5 kV IGBT is five with NPC rectifier (Case 1 and 3). The H bridge on LV side of DAB uses 1200 V, 450A IGBTs (SEMiX703GB126HDs) [23]. The transformer ratio is selected to achieve unity DC voltage gain to facilitate soft-switching for most of the load range.

Three cascaded H-bridges were used to achieve the selected DC-link voltage (again 15 % over the reverse diode voltage [20]). The same 6.5 kV IGBTs as previously described [22] were selected for the cascaded H-bridges. In all cases, converters were connected to the grid through an inductor to achieve a current THD less than 5%. Three interleaved DAB bridges are used for each phase to accommodate MVDC link voltage. For fair comparison the equivalent switching frequency in all the converters is kept same. Single inverter on LV side is used in case 1 and 2, and 1200 V, 2400 A IGBTs (FZ2400R12HE4-B9) [22] were considered for simulation studies. Three inverters in parallel with interleaved operation is used with separate or common DC-links in case 2, 4 and 5. With interleaved operation the device can be switched at a lower frequency (one third as three inverters are used) for a given THD requirement. The current sharing is realized by conventional master slave control and hence 1200 V, 800 (CM800DY-24S) [24] switches are used for interleaved inverters. For this study only the semiconductor losses were considered and the passive elements, including DAB transformers, were assumed ideal. All the models were simulated with PLECS and the semiconductor losses are plotted in Figs. 14-18. The efficiency for the different configurations is shown in Fig. 19.

In all cases, MV side converter uses high voltage IGBTs (6.5 kV) which are hard switched. thus, Maximum loss occurs in the rectifier switching. The silicon area of the device is large, so the conduction loss is reasonable. The NPC-converter has three levels and DC-link voltage was selected as 17.88

kV. By using two series connected IGBTs, individual voltage across each of the devices is restricted to 4.47 kV. on the other hand, the voltage stress across IGBTs in CHB is 3.44 kV. Therefore, even though the equivalent switching frequency is same the switching loss in NPC rectifier is higher. The effective DC voltage gain of the DAB is chosen close to unity and hence soft switching can be achieved over larger operating range and reasonable efficiency may be achieved at low load conditions. The switching loss with interleaved inverters (LV side converters) is lower compared to single inverter cases. Whereas, conduction loss with interleaved operation is higher compared to single inverter cases due to the selection of devices, with different silicon areas. However, the overall losses in interleaved operation are lower than those of the single inverter cases. The cases 4 and 5 can give higher efficiency compared to other cases due to the presence of interleaved structure at both MV and LV side. The difference between common and separate DC link has implications on capacitor selection and circulating current (thus, common mode choke selection), but little effect in efficiency as shown in simulation results.

VII. CONCLUSION

Many topology combinations are possible for the ST in the distribution system. The ST presents many attractive features, however, the achieved efficiency using current generation IGBTs is still limited. For the case of Si devices, simulation results show that modular converters result in higher efficiency. Considering steady improvement in Si devices, using design optimization techniques and advance modular structures and their control to achieve better mission efficiency; can make ST a feasible option.

REFERENCES

- [1] D. Dujic, F. Kieferndorf, F. Canales, and U. Drogenik, "Power electronic traction transformer technology," in *Power Electronics and Motion Control Conference (IPEMC), 2012 7th International*, vol. 1, 2012, pp. 636–642.
- [2] J. Wang, A. Huang, W. Sung, Y. Liu, and B. J. Baliga, "Smart grid technologies," *Industrial Electronics Magazine, IEEE*, vol. 3, no. 2, pp. 16–23, 2009.
- [3] S. Bifaretti, P. Zanchetta, A. Watson, L. Tarisciotti, and J. Clare, "Advanced power electronic conversion and control system for universal and flexible power management," *Smart Grid, IEEE Transactions on*, vol. 2, no. 2, pp. 231–243, 2011.
- [4] L. Heinemann and G. Mauthe, "The universal power electronics based distribution transformer, an unified approach," in *Power Electronics Specialists Conference, 2001. PESC. 2001 IEEE 32nd Annual*, vol. 2, 2001, pp. 504–509 vol.2.
- [5] X. She, R. Burgos, G. Wang, F. Wang, and A. Huang, "Review of solid state transformer in the distribution system: From components to field application," in *Energy Conversion Congress and Exposition (ECCE), 2012 IEEE*, 2012, pp. 4077–4084.
- [6] J.-S. Lai, A. Maitra, A. Mansoor, and F. Goodman, "Multilevel intelligent universal transformer for medium voltage applications," in *Industry Applications Conference, 2005. Fourtieth IAS Annual Meeting. Conference Record of the 2005*, vol. 3, 2005, pp. 1893–1899 Vol. 3.
- [7] D. Grider, M. Das, A. Agarwal, J. Palmour, S. Leslie, J. Ostop, R. Raju, M. Schutten, and A. Hefner, "10 kv/120 a sic dmosfet half h-bridge power modules for 1 mva solid state power substation," in *Electric Ship Technologies Symposium (ESTS), 2011 IEEE*, 2011, pp. 131–134.
- [8] R. De Doncker, D. Divan, and M. Kheraluwala, "A three-phase soft-switched high power density dc/dc converter for high power applications," in *Industry Applications Society Annual Meeting, 1988., Conference Record of the 1988 IEEE*, 1988, pp. 796–805 vol.1.
- [9] H. Akagi and R. Kitada, "Control and design of a modular multilevel cascade btb system using bidirectional isolated dc/dc converters," *Power Electronics, IEEE Transactions on*, vol. 26, no. 9, pp. 2457–2464, 2011.
- [10] G. Ortiz, L. Fassler, J. Kolar, and O. Apeldoorn, "Application of the magnetic ear for flux balancing of a 160kw/20khz dc-dc converter transformer," pp. 2118–2124, 2013.
- [11] G. Ortiz, D. Bortis, J. W. Kolar, and O. Apeldoorn, "Soft-switching techniques for medium-voltage isolated bidirectional dc/dc converters in solid state transformers," in *IECON 2012 - 38th Annual Conference on IEEE Industrial Electronics Society*, 2012, pp. 5233–5240.
- [12] G. B. P. K. J. Popczyk and R. Strzelecki, "Power electronic systems as a crucial part of smart grid infrastructure a survey,," *Bulletin of the Polish Academy of Sciences Technical Sciences*, vol. 59, no. 4, 2011.
- [13] S.-Y. Lee, M.-H. Woo, J.-K. Kim, and S.-P. Ryu, "A novel method to improve output voltage quality of grid-connected cascaded h-bridge multilevel converter with phase-shifted pwm and serial bus communication," in *Energy Conversion Congress and Exposition (ECCE), 2012 IEEE*, 2012, pp. 4513–4518.
- [14] Y.-M. Park, J.-Y. Yoo, and S.-B. Lee, "Practical implementation of pwm synchronization and phase-shift method for cascaded h-bridge multilevel inverters based on a standard serial communication protocol," *Industry Applications, IEEE Transactions on*, vol. 44, no. 2, pp. 634–643, 2008.
- [15] G. Prytz, "A performance analysis of ethercat and profinet irt," in *Emerging Technologies and Factory Automation, 2008. ETFA 2008. IEEE International Conference on*, 2008, pp. 408–415.
- [16] R. Teodorescu, E.-P. Eni, L. Mathe, and P. Rodriguez, "Modular multilevel converter control strategy with fault tolerance," in *International Conference on Renewable Energies and Power Quality (ICREPQ13)*, 2013.
- [17] S. Madhusoodhanan, K. Hatua, S. Bhattacharya, S. Leslie, S.-H. Ryu, M. Das, A. Agarwal, and D. Grider, "Comparison study of 12kv n-type sic igbt with 10kv sic mosfet and 6.5kv si igbt based on 3l-npc vsc applications," in *Energy Conversion Congress and Exposition (ECCE), 2012 IEEE*, 2012, pp. 310–317.
- [18] J. Wang, G. Wang, S. Bhattacharya, and A. Huang, "Comparison of 10-kv sic power devices in solid-state transformer," in *Energy Conversion Congress and Exposition (ECCE), 2010 IEEE*, 2010, pp. 3284–3289.
- [19] N. Kaminski, "State of the art and the future of wide band-gap devices," in *Power Electronics and Applications, 2009. EPE '09. 13th European Conference on*, 2009, pp. 1–9.
- [20] V. Kaura and V. Blasko, "Operation of a voltage source converter at increased utility voltage," in *Power Electronics Specialists Conference, 1995. PESC '95 Record., 26th Annual IEEE*, vol. 1, 1995, pp. 523–528 vol.1.
- [21] R. Withanage, N. Shammass, and S. Tennakoon, "Series connection of insulated gate bipolar transistors (igbts)," in *Power Electronics and Applications, 2005 European Conference on*, 2005, pp. 10 pp.–P.10.
- [22] "Datasheet information on power semiconductors." Infineon Technologies AG., [Online]. Available: <http://www.infineon.com>.
- [23] "Catalogue 2013/2014," Semikron, [Online]. Available: <http://www.semikron.com>.
- [24] Powerex, [Online]. Available: <http://www.pwr.com>.