



**Preferred test conditions for determining hearing thresholds for standardization / ISO/TC 43/WG1 "Threshold of Hearing", convened by Henrik Møller**

Møller, Henrik

*Published in:*  
International Journal of Audiology

*Publication date:*  
1996

[Link to publication from Aalborg University](#)

*Citation for published version (APA):*

Møller, H. (1996). Preferred test conditions for determining hearing thresholds for standardization / ISO/TC 43/WG1 "Threshold of Hearing", convened by Henrik Møller. *International Journal of Audiology*, 25(1), 45-51.

**General rights**

Copyright and moral rights for the publications made accessible in the public portal are retained by the authors and/or other copyright owners and it is a condition of accessing publications that users recognise and abide by the legal requirements associated with these rights.

- Users may download and print one copy of any publication from the public portal for the purpose of private study or research.
- You may not further distribute the material or use it for any profit-making activity or commercial gain
- You may freely distribute the URL identifying the publication in the public portal -

**Take down policy**

If you believe that this document breaches copyright please contact us at [vbn@aub.aau.dk](mailto:vbn@aub.aau.dk) providing details, and we will remove access to the work immediately and investigate your claim.

# Preferred Test Conditions for Determining Hearing Thresholds for Standardization

By ISO/TC 43/WG 1 Threshold of Hearing

## Introduction

The International Organization for Standardization (ISO), Technical Committee 43 'Acoustics', Working Group 1 'Threshold of Hearing' is responsible for the production of standards that describe human hearing thresholds for use in the calibration of audiometric equipment.

For free-field and diffuse-field listening conditions, the threshold values refer to sound pressure levels measured at the position of the subject but without the subject. For earphone listening, the threshold values are *equivalent threshold sound pressure levels*, which means sound pressure levels measured in an acoustic coupler, an artificial ear or an ear simulator, when the earphone is supplied with the voltage corresponding to the threshold. Similarly, for bone vibrators, the values are *equivalent threshold force levels* measured as force levels delivered to a mechanical coupler. In any case, values for calibration are given as *reference* (equivalent) thresholds, which means median, modal or mean values of (equivalent) thresholds for specified groups of subjects.

Until recently, calibration values for audiometry have been found in a number of standards. The basic standard ISO 389 [1], which gives reference equivalent threshold sound pressure levels (RETSPLs) for supra-aural earphones in the frequency range 125 Hz to 8 kHz, has been the basis for calibration of audiometers for many years. Calibration values for other transducers and sound fields, and for other signals have been found in other standards (ISO 389/DAM 1 [2] for insert earphones, ISO 7566 [3] for bone vibrators, ISO 8798 [4] for masking noise, and ISO 226 [5] for free-field and diffuse-field presentation).

Developments in audiometry have led to the need for additional information, which relates to new types of signals and new types of earphones. Along with this development it has been agreed that all of the standards should be brought together under the ISO 389 number and a common heading, which has been chosen as:

**ISO 389: Acoustics—Reference zero for the calibration of audiometric equipment.**

It has been planned that the ISO 389 series should include the following parts:

**Part 1 (?): Reference equivalent threshold sound pressure levels for pure tones and supra-aural earphones** (planned revision of present ISO 389. Title to be revised, as the revision will cover circum-aural earphones as well).

**Part 2 (1994): Reference equivalent threshold sound pressure levels for pure tones and insert earphones** (previously ISO 389/DAM 1).

**Part 3 (1994): Reference equivalent threshold force levels for pure tones and bone vibrators** (previously ISO 7566).

**Part 4 (1994): Reference levels for narrow-band masking noise** (previously ISO 8798).

**Part 5 (?): Reference equivalent threshold sound pressure levels for pure tones in the frequency range 8 kHz to 16 kHz.**

**Part 6 (?): Reference equivalent threshold sound pressure levels for acoustic test signals of short duration.**

**Part 7 (1996?): Reference threshold of hearing under free-field and diffuse-field listening conditions** (revision of thresholds from ISO 226).

It will be noted that Parts 5 and 6 have not yet been issued, and reference thresholds remain to be produced for these standards. Furthermore, some of the values of the present ISO 389 have been questioned from time to time, and Working Group 1 (WG 1) has decided to re-examine these, and if needed revise them, before issuing Part 1. The preparation of Parts 1, 5 and 6 is among the present work items of WG 1.

WG 1 bases its work on data from independent laboratories throughout the world. Unfortunately, problems have existed in the past in trying to relate the data from experiments carried out by different workers in different parts of the world, all of which

have had the same objective, but lacked a common set of criteria for subject selection, methods of test, in reporting of data etc.

In order to collate the data that are being produced, or will be produced in the future, and to encourage other workers to participate in these activities, WG 1 has produced a set of *Preferred Test Conditions* for measuring thresholds for use in standardization. The test conditions are aimed at making the collation of future work easier, which in turn should lead to a more rapid production of relevant standards. The use of preferred test conditions [6] was previously tried successfully in connection with collection of data for ISO 389-7, as reported by Brinkmann et al. [7].

The test conditions below are set out in the form of general requirements that apply to all forms of threshold measurements, and specific requirements that apply to the individual documents in question (at present Parts 1, 5 and 6).

The qualification criteria for subjects as specified in the general requirements deserve a few comments. Previously, it has been customary to select subjects with normal hearing, specified by a certain maximum hearing threshold level (according to ISO 8253-1 [8]) for the frequency range 125 Hz–8 kHz. This procedure might lead to an over-selection of the subjects, and the procedure becomes especially questionable when considering reference thresholds for Part 1, in which case the selection criteria would use the values under examination. Therefore, WG 1 has decided that the qualification should only relate to the issue of the subjects being otologically normal (see Clause 1.3). In order to facilitate a subsequent reworking of data, such as examination of the distribution of data and a possible exclusion of single subjects, it was decided that all data should be reported on each individual subject. Thus subjects should not be excluded on the basis of an audiogram (but the audiogram should be reported).

WG 1 would welcome contributions from researchers particularly in the form set out in the following *Preferred Test Conditions*. Contributions should be sent to the Convener at the address below.

## General requirements

### 1. Test subjects

- 1.1. At least 25 subjects shall participate, both males and females, preferably represented in equal numbers.
- 1.2. The subjects shall be in the age range 18 to 25 years inclusive.

1.3. The subjects shall be otologically normal, i.e. be in a normal state of health, be free from all signs or symptoms of ear disease and from obstructing wax in the ear canals, and have no history of undue exposure to noise, exposure to potentially ototoxic drugs or familial hearing loss. An example of a questionnaire serving to examine the history is given in Annex A.

1.4 It is recommended that tympanometry be performed at the beginning of each test session. Hearing threshold measurements shall be performed only if a middle ear pressure in the range  $\pm 50$  daPa has been obtained.

1.5. Monaural hearing threshold levels shall be determined according to ISO 8253-1.

### 2. Test procedure

Bracketing or ascending method according to ISO 8253-1 shall be used. Each subject shall have at least one training session with two or three selected test signals.

### 3. Calibration

Calibration of test equipment shall be performed at regular intervals to ensure that levels are within those specified in the prevailing data. The uncertainty of sound pressure level measurements shall not exceed 0.5 dB.

### 4. Maximum ambient noise levels

4.1. The acoustic environment where the test subjects are located during testing shall fulfil the requirements in Clause 11.1 of ISO 8253-1 for measurement of hearing levels down to  $-10$  dB with a maximum uncertainty of  $+2$  dB due to ambient noise. The requirements for 8 kHz shall be applied also for the 1/3-octave bands from 10 kHz–16 kHz.

4.2. For typical current supra-aural earphones (such as Telephonics TDH 39 with MX 41/AR cushion and Beyer DT 48) with sound attenuation as given in Table 3 of ISO 8253-1, the requirement of Clause 4.1 means that noise levels shall be at least 10 dB below the levels given in Table 2 of ISO 8253-1.

4.3. If the sound attenuation provided by the actual earphone differs from the values in Table 3 of ISO 8253-1, maximum permissible noise levels shall be modified accordingly. For information, sound attenuation is given below for Sennheiser HDA 200 and Koss HV/1A Plus earphones (as measured

Frequency in Hz		63	125	250	500	1000	2000	4000	8000
Attenuation in dB	HDA 200	16.7	14.3	15.9	22.5	28.6	32.0	45.7	43.8
mean values	HV/1A Plus	0.1	0.6	0.8	1.5	0.8	-2.3	9.3	3.7

according to ISO 4869-1 at the Physikalisch Technische Bundesanstalt, Germany).

### 5. Force of application

It should be noted that different types of earphones require different values of force of application to the ear and to the coupler or artificial ear. Some examples are: Koss HV/1 A Plus or equivalent:  $3.5\text{ N} \pm 0.5\text{ N}$ . Telephonics TDH 39 and TDH 49/50, Beyer DT 48:  $4.5\text{ N} \pm 0.5\text{ N}$ . Sennheiser HDA 200:  $10.0\text{ N} \pm 1.0\text{ N}$ .

The values refer to the force exerted by the headband when the opposing faces of the ear-cushions are separated by 145 mm. The earphone shall be applied to the coupler or artificial ear with the nominal static force of the same value, not including the weight of the earphone itself.

### 6. Audiometric equipment

The audiometric equipment which is used for control of stimulus gating and stimulus level and for execution of the test procedure shall fulfil the relevant requirements according to IEC 645-1 [9], IEC 645-3 [10] (only for short duration signals), and IEC 645-4 [11] (only for extended high-frequency signals). Special care has to be taken that no sound coinciding with the tone and attenuator switching can be detected by a test subject.

### 7. Reporting of data

7.1. In general, data shall be reported for each individual subject, including: (a) results for the actual test stimuli, (b) monaural hearing thresholds as determined according to Clause 1.5, (c) other relevant information obtained according to Clauses 1.2, 1.3 and 1.4, such as age and sex of subject, and the results of the tympanometry.

7.2. In addition, median values, modal values, mean values and standard deviations of the results may be given for the total group and for subgroups, such as male and female subjects, or different age ranges, e.g. 18–21 years and 22–25 years.

7.3. Earphones and coupler, artificial ear or ear

simulator shall be described as detailed as possible, for the earphones including manufacturer, type, version, cushion, etc. Details shall be given of the fitting of the earphone on test subjects and to coupler, artificial ear or ear simulator, including the applied force.

7.4. A calibrated frequency response curve of the earphones as measured with the coupler, artificial ear or ear simulator shall be provided. For short duration signals (see Clause 12), also the acoustic waveforms shall be given.

7.5. Any other relevant information shall be reported, such as audiometric equipment used, attenuator step size, test procedure, etc.

### Specific requirements, 125 Hz to 8 kHz range (for future ISO 389-1)

#### 8. Acoustic test signals

8.1. Pure tones of the following audiometric frequencies in kHz shall be used:

0.125 0.25 0.5 0.75 1 1.5 2 3 4 6 8

As optional frequencies, 1/3 octave frequencies according to ISO 266 [12] may be used.

8.2. The maximum permissible deviation from nominal frequency shall be 0.1%.

8.3. Each tone shall be presented monaurally with a duration of 1–2 s and the tone switching shall meet the requirements in Clause 7.6 of IEC 645-1.

8.4. At any frequency, the dynamic range of test tone levels shall be at least  $\pm 30\text{ dB}$  relative to the expected average equivalent threshold sound pressure level.

8.5. Results shall be given as equivalent threshold sound pressure levels in a stated acoustic coupler, artificial ear or ear simulator.

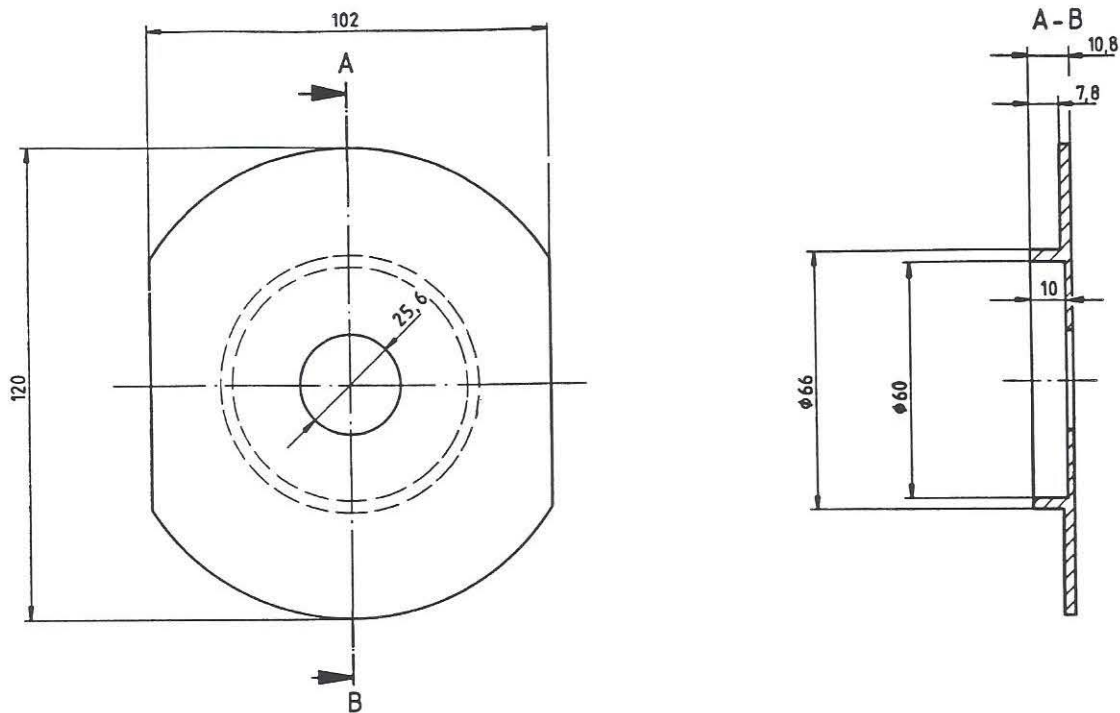

Fig. 1. Type 1 adapter for use with IEC-318 ear simulator (all dimensions in mm).

### 9. Transducers

9.1. Stimuli may be presented by means of supra-aural earphones fulfilling the specifications in Clause 4.2 in the present ISO 389. Other types of earphones may also be used if reproducible calibration can be obtained. The circum-aural earphone Sennheiser HDA 200 is an example of such a transducer.

9.2. Calibration of supra-aural earphones shall be performed on an artificial ear according to IEC 318 [13].

9.3. Calibration of circum-aural earphones shall be performed on an artificial ear according to IEC 318 with a Type 1 flat plate adapter and conical ring as specified in IEC/Second CD 1671 [14], and as shown in Figures 1 and 3 (adapter and conical ring manufactured by Brüel and Kjær as DB 0843 and YJ 0304, respectively).

### Specific requirements, 8 kHz to 16 kHz range (for future ISO 389-5)

#### 10. Acoustic test signals

10.1. Pure tones of the following preferred frequencies in kHz, according to ISO 266:

8 9 10 11.2 12.5 14 16

The order of test frequencies shall be randomized.

10.2. The maximum permissible deviation from nominal frequency shall be 0.1%.

10.3. Each tone shall be presented monaurally with a duration of 1–2 s and the tone switching shall meet the requirements in Clause 7.6 of IEC 645-1.

10.4. At any frequency up to 14 kHz, the dynamic range of test tone levels shall be at least  $\pm 30$  dB relative to the expected average equivalent threshold sound pressure level. At 16 kHz the corresponding range should be at least  $\pm 40$  dB.

10.5. Results shall be given as equivalent threshold sound pressure levels in a stated acoustic coupler, artificial ear or ear simulator.

### 11. Transducers

11.1. Preferably, either Sennheiser HDA 200 or Koss HV/1A Plus earphones shall be used. Other types of earphones may also be used if reproducible calibration can be obtained.

11.2. The Sennheiser HDA 200 shall be calibrated as described in Clause 9.3.

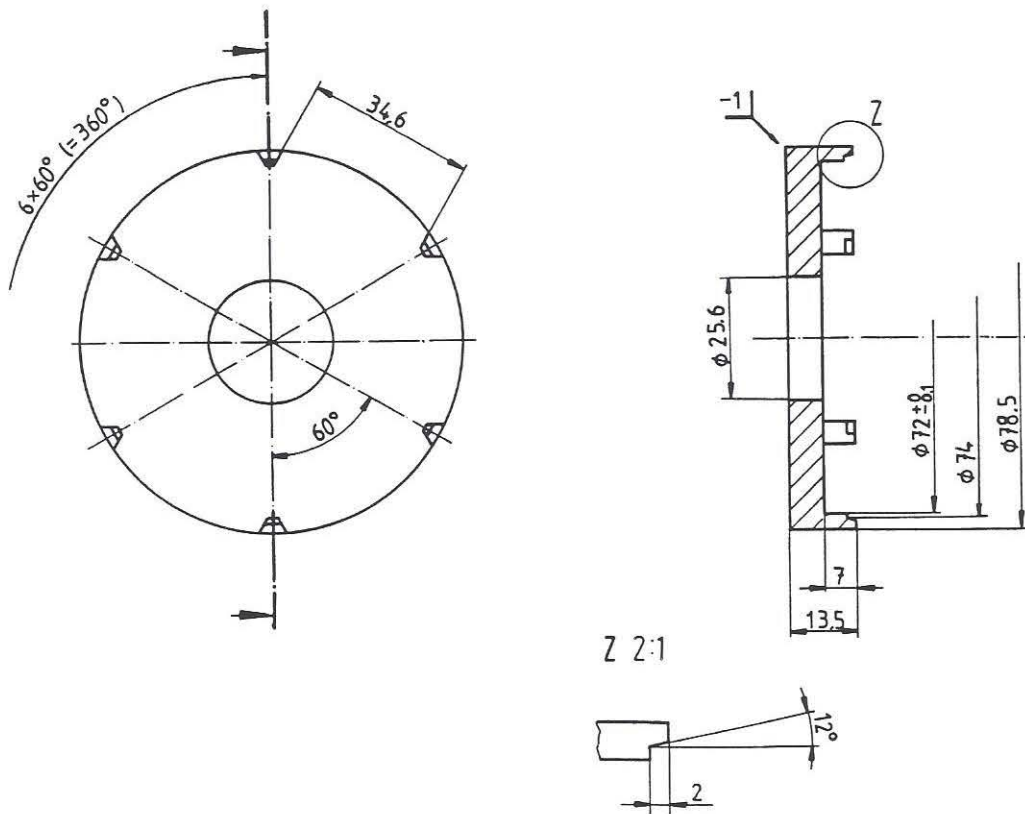

Fig. 2. Type 2 adapter for use with IEC-318 ear simulator (all dimensions in mm).

11.3. The Koss HV/1 A Plus or equivalent shall be calibrated with an ear simulator according to IEC 318 with a Type 2 adapter as specified in IEC/Second CD 1671, and as shown in Figures 2 and 4. Alternatively, a rubber type CHF 10 coupler may be used.

11.4. Experimenter supervised fitting of the earphones shall be used, followed by adjustment by the test subject to maximum loudness of an 8 kHz test tone.

### Specific requirements, short duration signals (for future ISO 389-6)

#### 12. Acoustic test signals

12.1. Broadband clicks as well as brief tones shall be used (1) as single stimuli and (2) as bursts of stimuli with a repetition rate of 20 per second. Each burst shall have a duration of 1–2 s and envelope rise and fall times as specified in Clause 7.6 of IEC 645-1. Stimulation shall be monaural.

12.2. Broadband clicks shall have an electric waveform according to Clause 4.1 of IEC 645-3. The waveform consists of a rectangular pulse (single monophasic square wave) having the following specifications: Duration:  $100 \mu\text{s} \pm 10 \mu\text{s}$ . Rise and fall times:  $< 25 \mu\text{s}$ . The click polarity as verified acoustically shall be rarefaction for single clicks and alternating for bursts of clicks (see Clause 12.1).

*Note:* For this verification to be reliable, the polarity of the measurement system has to be known. Be aware that commercial microphones, preamplifiers and measuring amplifiers may give phase shifts.

12.3. Brief tones shall have an electric waveform according to Clause 4.2 of IEC 645-3. This has linear rise and fall times of 1.6 periods of the modulated frequency and a duration of three periods. Each tone shall start in the same phase from a zero crossing. The modulated frequencies shall comprise at least 500 Hz and 1, 2, 4, and 8 kHz.

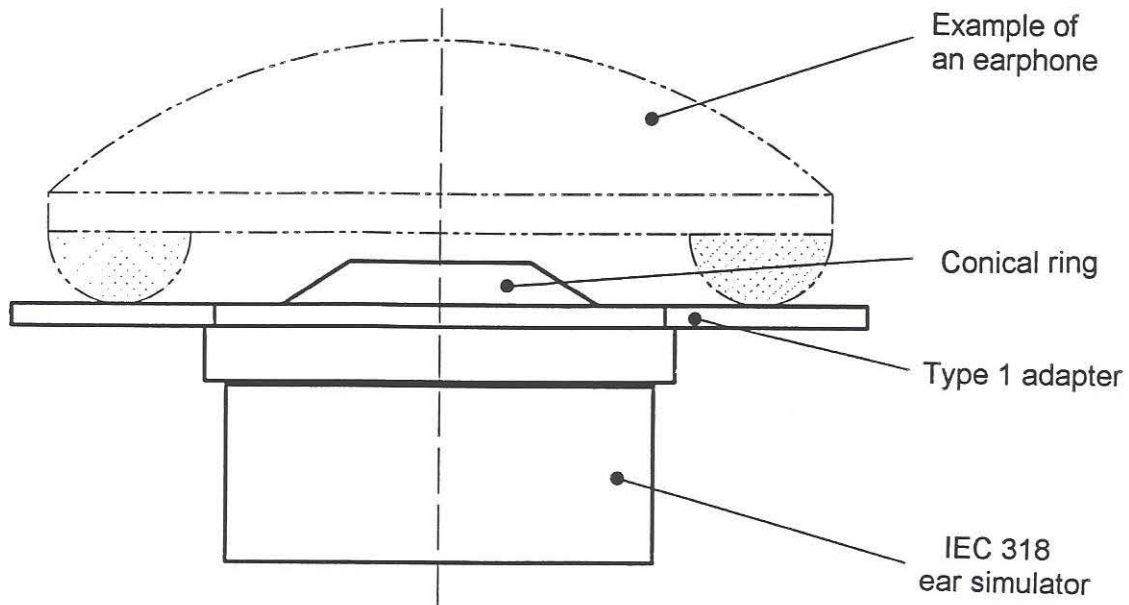

Fig. 3. Position of Type 1 adapter on the IEC-318 ear simulator.

12.4. At the frequencies where measurements are made for brief tones according to Clause 12.3, measurements shall also be made with longer tones (1–2 s), using the same equipment (earphone, coupler, etc.) and the same test procedure. These measurements may be the same as those carried out to fulfil Clause 1.5.

12.5. Results shall be given as equivalent threshold peak-to-peak equivalent sound pressure levels (peSPL) in a stated acoustic coupler, artificial ear or ear simulator as specified in Clause 3.10 of IEC 645-3, except for longer tones according to Clause 12.4, for which normal (r.m.s.) equivalent threshold sound pressure levels shall be given.

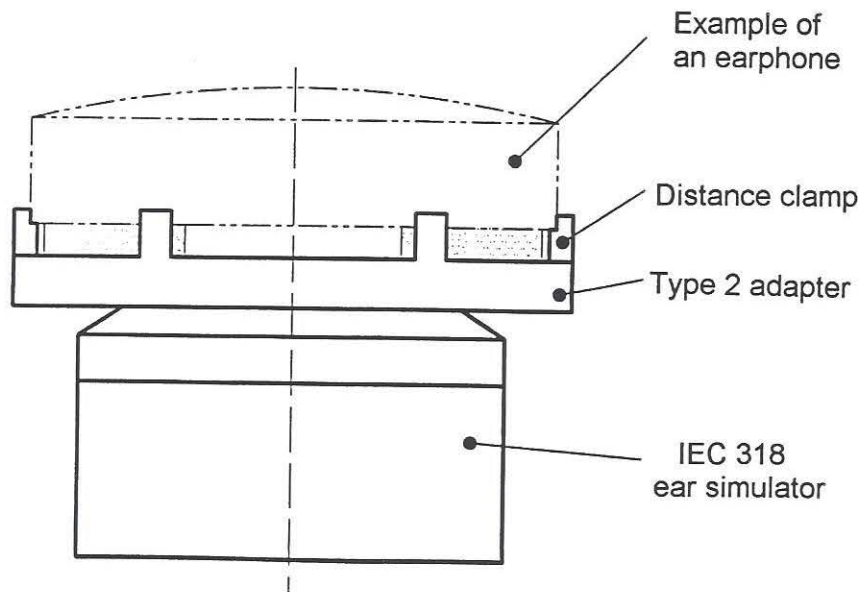

Fig. 4. Position of Type 2 adapter on the IEC-318 ear simulator.

### 13. Transducers

Stimuli shall be presented by means of either supra-aural earphones fulfilling the specifications in Clause 4.2 of the present ISO 389 or insert earphones as defined in ISO 389-2. Other types of earphones may be used if reproducible calibration can be obtained. Calibration shall be performed on either an artificial ear according to IEC 318 for supra-aural earphones or an ear simulator according to IEC 711 [15] for insert earphones.

#### *Address of convener:*

Henrik Møller  
Acoustics Laboratory  
Aalborg University  
Fredrik Bajers Vej 7B  
DK-9220 Aalborg Ø  
Denmark

Telephone: +45 9815 1244

Telefax: +45 9815 2144

e-mail: hm@kom.auc.dk

### References

- [1] ISO 389 (1991): Acoustics—Standard reference zero for the calibration of pure-tone air conduction audiometers.
- [2] ISO 389/DAM 1 (1991): Acoustics—Standard reference zero for the calibration of pure-tone air conduction audiometers. Amendment 1.
- [3] ISO 7566 (1987): Acoustics—Standard reference zero for the calibration of pure-tone bone conduction audiometers.
- [4] ISO 8798 (1987): Acoustics—Reference levels for narrow-band masking noise.
- [5] ISO 226 (1987): Acoustics—Normal equal-loudness contours.
- [6] ISO/TC 43/WG 1 N 122 (1988): Preferred test conditions for the determination of the minimum audible field and the normal equal-loudness level contours (revision of ISO 226).
- [7] Brinkmann K, Vorländer M, Fedtke T. Re-determination of the threshold of hearing under free-field and diffuse-field listening conditions. *Acustica* 1994; 80: 453–62.
- [8] ISO 8253-1 (1989): Acoustics—Audiometric test methods—Part 1: Basic pure tone air and bone conduction threshold audiometry.
- [9] IEC 645-1 (1992): Audiometers—Part 1: Pure-tone audiometers.
- [10] IEC 645-3 (1994): Audiometers—Part 3: Auditory test signals of short duration for audiometric and neuro-otological purposes.
- [11] IEC 645-4 (1994): Audiometers—Part 4: Equipment for extended high-frequency audiometry.
- [12] ISO 266 (1975): Acoustics—Preferred frequencies for measurements.
- [13] IEC 318 (1970): An IEC artificial ear, of the wide band type, for the calibration of earphones used in audiometry.
- [14] IEC/Second CD 1671 (in preparation): IEC 318 ear simulator adapters for the calibration of audiometric earphones in the extended high frequency range.
- [15] IEC 711 (1981): Occluded-ear simulator for the measurement of earphones coupled to the ear by ear inserts.

## ANNEX A

### Questionnaire for hearing tests

1. Name ..... Date of birth .....
2. Have you ever had trouble with your hearing (for example, infections, ear noises, drainage, etc.?)  
 yes  no If yes, please detail: .....
3. Have you ever had an operation in your ear?  yes  no If yes, please detail .....
4. Have you ever taken drugs, tablets or been given injections that affected your hearing?  yes  no
5. Have you ever worked for a long time in a place that was very noisy, i.e., where it was difficult to communicate?  
 yes  no If yes, please detail: .....
6. Did you wear any hearing protector at that time?  yes  no
7. Did you attend pop/rock concerts or discotheques?  (almost) never  sometimes  often
8. Do you play any musical instrument?  yes  no If yes, please specify: .....
9. Do you listen to Walkman/Freestyle?  (almost) never  sometimes  (almost) daily
10. Have you been exposed to any loud sounds from e.g. motorbikes, chain-saws, gunfire, fire-crackers, explosions?  yes  no If yes, what kind and how often? .....
11. Does/did anyone in your immediate family have a hearing disorder?  yes  no  
If yes, please specify: .....
12. Have you ever had a hearing test before?  yes  no If yes, when and where? .....

I agree with the storage of my data and their use in connection with the threshold measurements.

Date: .....

Signature: .....