



Aalborg Universitet

AALBORG UNIVERSITY
DENMARK

Next-Generation Shipboard DC Power System

Introduction Smart Grid and dc Microgrid Technologies into Maritime Electrical Networks

Jin, Zheming; Sulligoi, Giorgio; Cuzner, Rob; Meng, Lexuan; Quintero, Juan Carlos Vasquez; Guerrero, Josep M.

Published in:
I E E E Electrification Magazine

DOI (link to publication from Publisher):
[10.1109/MELE.2016.2544203](https://doi.org/10.1109/MELE.2016.2544203)

Publication date:
2016

Document Version
Early version, also known as pre-print

[Link to publication from Aalborg University](#)

Citation for published version (APA):
Jin, Z., Sulligoi, G., Cuzner, R., Meng, L., Quintero, J. C. V., & Guerrero, J. M. (2016). Next-Generation Shipboard DC Power System: Introduction Smart Grid and dc Microgrid Technologies into Maritime Electrical Networks. *I E E E Electrification Magazine*, 4(2), 45-57. <https://doi.org/10.1109/MELE.2016.2544203>

General rights

Copyright and moral rights for the publications made accessible in the public portal are retained by the authors and/or other copyright owners and it is a condition of accessing publications that users recognise and abide by the legal requirements associated with these rights.

- ? Users may download and print one copy of any publication from the public portal for the purpose of private study or research.
- ? You may not further distribute the material or use it for any profit-making activity or commercial gain
- ? You may freely distribute the URL identifying the publication in the public portal ?

Take down policy

If you believe that this document breaches copyright please contact us at vbn@aub.aau.dk providing details, and we will remove access to the work immediately and investigate your claim.

Next-Generation Shipboard DC Power System:

Introduction Smart Grid and dc Microgrid Technologies into Maritime Electrical Networks

Zheming Jin¹, Giorgio Sulligoi², Rob Cuzner³, Lexuan Meng¹, Juan C. Vasquez¹ and Josep M. Guerrero¹

¹Department of Energy Technology, Aalborg University, Denmark

²Department of Engineering and Architecture, University of Trieste, Italy

³Department of Electrical Engineering, University of Wisconsin-Milwaukee, USA
{zhe, lme, juq, joz}@et.aau.dk, giorgio.sulligoi@di3.units.it, cuzner@uwm.edu

In recent years, more and more evidence suggests that the global energy system is on the verge of a drastic revolution. The evolutionary development in power electronic technologies, the emerging high-performance energy storage devices, as well as the ever increasing penetration of renewable energy sources (RES) are commonly recognized as the major driven force of the revolution, the outburst of customer electronics and new kinds of household electronics is also powering this change. In this context, dc power distribution technologies have made a comeback and keep gaining a commendable increase in research interests and industrial applications. In addition, the concept of flexible and smart distribution has also been proposed, which tends to exploit distributed generation and pack the distributed RESs and local electrical loads as an independent and self-sustainable entity, namely microgrid. At present, the research of dc microgrid has investigated and developed a series of advanced methods in control, management and objective-oriented optimization, which would found the technical interface enabling the future applications in multiple industrial areas, such as smart buildings, electric vehicles, aerospace/aircraft power systems, as well as maritime power systems.

Maritime power system could be traced back to the 1880s, starting with the earliest record of a dc based onboard power system on the *SS Columbia*, where Edison's dc lighting system was firstly installed. In the last century, maritime power system has been greatly developed along with the increasing demand of onboard electrical loads. During such a development, shipboard power transformed from Edison's dc power system into Tesla's ac power system, as the usage of electricity extended from the initial lighting into almost each aspect aboard a vessel where it was necessary to build upon the advances in the ac distribution infrastructure. In the recent years, the regulation of emission from governments is ever increasingly stricter, the fuel-efficiency requirement from the customers are also rising correspondingly. It results in the current trends towards more efficient ships, the most representative concept is the all-electric ship (AES), which exploits the electrical propulsion system instead of conventional mechanical propulsion system. One of the significant features of AES is the concept of integrated power system (IPS) which minimizes the number of generators in ship by incorporating intelligent methods for meeting load demands through multiple paths and dynamically matches generational capability to loading needs. In broad terms, the shipboard IPS can be regarded as a large-scaled onboard microgrid with specific requirements. In recent studies, current research trend of IPS is turning to dc power distribution system, thus, has resulted in advanced research outcomes in dc microgrid field, especially its advanced control, management and optimization methods, all of which can be substituted to a wide body of AES research.

DC power architecture

Queen Elizabeth II, the world's first cruise vessel with electric propulsion system, is a high-profile example of existing ac shipboard power system. The power architecture of its shipboard power system is as shown in Fig.1. The vessel was built in 1968, originally steam powered, and converted from steam to diesel-

electric propulsion in the 1987. The vessel was refitted with nine diesel generator sets rated 10.5MW at 10kV. The electrical power plant is connected with the vessel's main bus, driving the two major 44-MW electric propulsion systems. The auxiliary loads and the hotel service loads are powered through transformers and power electronic converters. The conversion to diesel-electric power system was expected to improve the fuel efficiency up to 35% at the vessel's service speed of 28.5kn and save £12 million a year in fuel costs. However, along with the deepening of the study, researchers and engineers have noticed the inadequacies of AC power architecture that can be summarized as follows:

- Generator sets have to work in fixed speed, and thus limit the further improvement in fuel efficiency;
- AC power architecture introduces unwanted reactive power flow and power quality problems (e.g. three phase imbalances and harmonic currents);
- The bulky conventional transformers occupy too much valuable space and weight onboard;
- Potential risk of systemic disintegration when supporting emerging pulsed electrical loads.

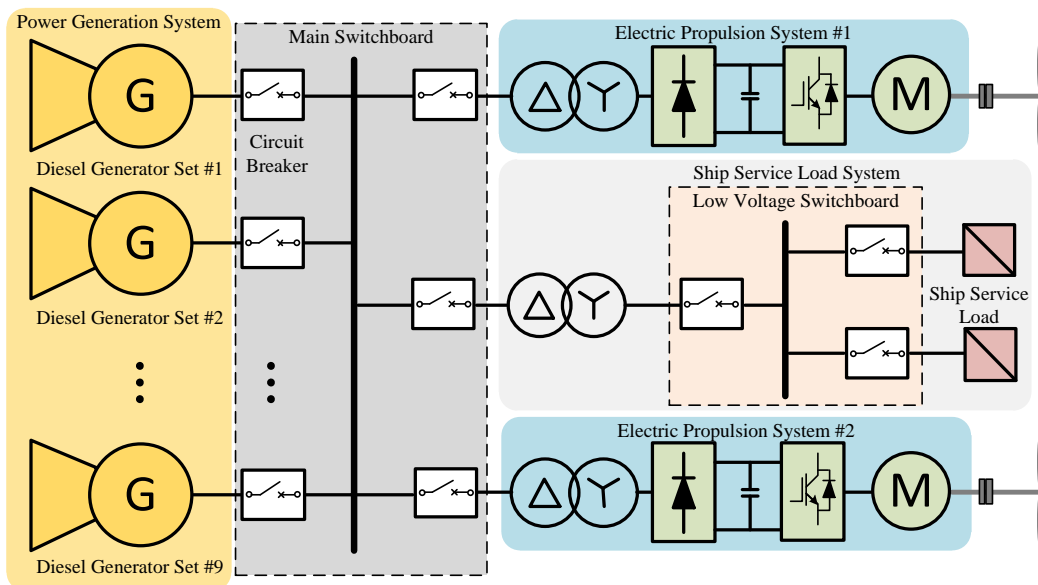

Fig.1 Diesel-Electric Shipboard Power System of the *Queen Elizabeth II*

These problems are also plaguing the researcher and engineers of terrestrial power distribution systems, which results in the current trends of returning to dc based power distribution system. Edison's dc power system has once again led the second industrial revolution and brought a new era of light as well as electrification to the mankind. However, it has been overshadowed after losing the famous "Battle of the Currents" for more than a century due to its inherent inability of changing voltage levels at that time without the additional of multiple motor-generator sets--thus making the system uneconomical to operate compared with the ac power system (which had at its disposal the simple transformer for changing voltage levels). Thanks to the rapid development of modern power electronic technologies, high-frequency dc-dc converter has already qualified for taking on the role of transformers in dc systems. It, therefore, may allow Edison's invention to change the world once more. Just as Edison once strived to prove, the dc power system has several major advantages over ac power system and even some new advantages, such as:

- Replacing bulky ferromagnetic transformer by compact power electronic converters;
- Easier parallel connection or disconnection for dc power sources;
- Elimination of harmonic and imbalance problems;
- Elimination of synchronization problems;
- Elimination of reactive power flow;

Additionally, considering the specific need of shipboard power systems, dc based IPS could bring a broad range of advantages, for both commercial and mission-oriented ships. Generally, the dc power architecture will eliminate the bulky low-frequency transformers and reduce the rating of switchgear, thus reducing the occupied space and overall weight of the whole system, which may result in extra cargo space. The commercial sector focuses on the 15% fuel saving due to allowing variable speed diesel generators, whereas the military application are interested in support for advance electrical equipment and weapons, which characteristic in high-power pulsed loads. For these vessels meeting these objectives requires highly secured power supply (mainly warships), and a dc power architecture could also provide better survivability and limitation of fault current, as well as reconfiguration capability. Besides that, integration of advanced high-speed high-efficiency diesel generation (i.e. gas turbine generation) could also be easily achieved within the dc power architecture, which could effectively improve the fuel efficiency of the system. Due to the higher power levels required in AES application, the only available design option for dc based IPS is the medium-voltage dc (MVDC) solution with a DC bus voltage above 1kV.

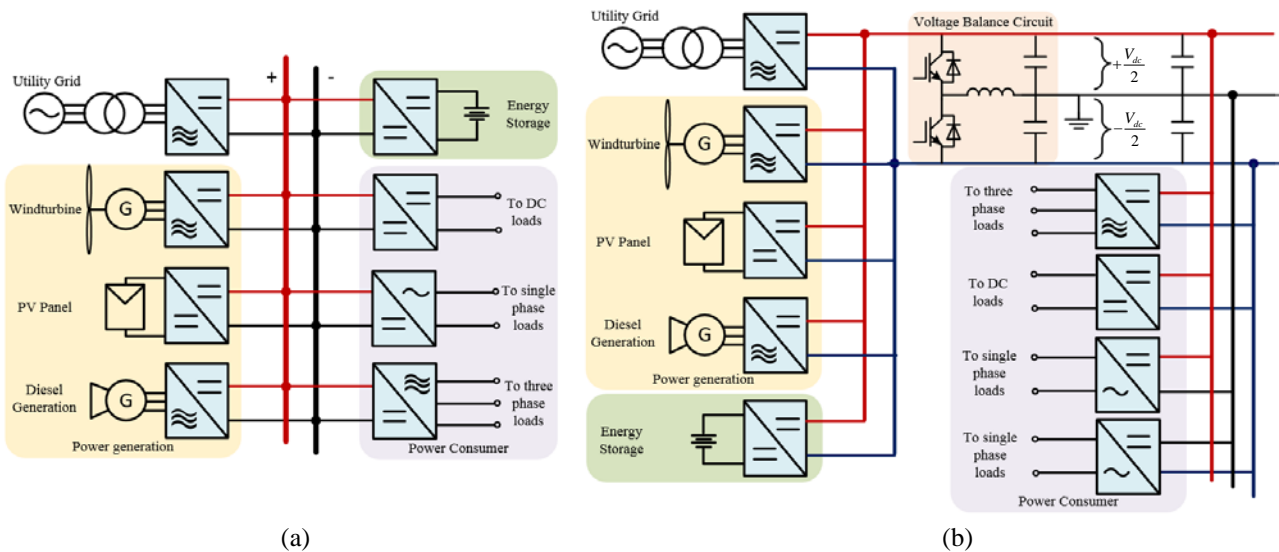

Fig.2 Typical power architecture of single bus DC microgrids (a)common architecture. (b)bipolar architecture.



Fig.3 Ring-bus based DC microgrid

The typical power architecture of terrestrial dc microgrids is shown in Fig.2(a), where the renewable energy sources (RESs), energy-storage systems (ESSs) and local electrical loads are “packaged” together with the dc bus in order to enable islanding operation that makes the system fully resistant to major blackouts in the main grid. The elimination of reactive power and synchronization problems make the whole system much simpler to design, control and coordinate. Moreover, with a well-selected nominal bus voltage, the overall efficiency will be generally higher than its ac counterpart. The three-wire bipolar-type dc microgrid power architecture is shown in Fig.2(b), the architecture evolves from the Edison’s three-wire dc power distribution system, which is initially designed to save conductors. Comparing with the typical architecture, the positive bus and negative bus can each other up, which result in the inherent redundancy and higher

reliability. Moreover, it allows using neutral bus with low rated current if the loads on positive bus and negative bus are roughly equal.

Fig.3 shows ring-bus based dc microgrid power architecture proposed for critical load with higher security requirement (e.g. datacenter). The ring-bus allows energy flows along either shortest path or sub-optimal path, i.e. wherever single fault occurs in the system it can be isolated by switching off the nearest circuit breakers and other parts are able to work as normal. This feature guarantees the system survival from single-point-failure. In addition, the ring-bus would allow the critical load to obtain energy from multiple nodes by applying either conventional multiple contact point switch or multi-terminal converters. Accordingly, the critical load is highly secured to achieve uninterrupted operation. A similar architecture can apply to the maritime power system but the inner part of the system will be divided into electrical zones corresponding to the feeds and it will typically be laid out with generational sources on the two sides, designated as port and starboard and with a simple cross-connect in the forward and aft parts of the system as shown in Fig.4(a). Such a system is commonly referred to as DC Zonal Electrical System or DC ZEDs. Fig.4(b) shows the layout of equipment within an electrical zone. Note that a large number of the loads within the zone are fed from both sides of ship in order to enhance survivability. As opposed to the terrestrial power system, the maritime power system is inevitably restricted by the cabin structure of the vessel or off-shore platform so size and weight of the overall system is important. In order to minimize dc cabling size MVDC voltage levels of greater than 6kV are proposed for future combatants. For architectures like the Fig.4(a), the switches around the ring bus are there to isolate faults that may occur on the buses that distribute power to the zones. There are two approaches: “Breaker-based” and “Breaker-less”. With “Breaker-based” architectures these switches must be actively controlled Solid State Circuit Breakers (SSCBs) combined with fast acting no load isolating mechanical switches. Such systems have a potential high quality of power during fault events, i.e. minimal power interruption, but the SSCB at these levels is a developmental item that still carries with it considerable risk. Intercommunications between the adjacent SSCBs is necessary in order to isolate the fault because the DC ZEDS must be able to provide the same current from any direction.

With “Breaker-less” architectures, the power converters that interface generational sources to the port and starboard buses play the primary role of driving current through to a fault on the bus to zero. The switches are all no load switches. In order to be “Breaker-less”, the architecture of Fig.4(a) cannot have cross-tie switches between to buses (i.e. where battery interfacing converters are) because when a fault occurs on a bus system operations requires that critical loads within the zones autonomously shift their power sources to the healthy opposite bus. This is accomplished by diode auctioneering of power sources fed from both sides of the ship into the loads. Inter-communications between the switches and converters is necessary in order determine where to isolate the fault. Once a switch isolates a fault, the power converters on the effective bus are reenergized and all but the faulted part of the system is restored to operation. Communications is considerably more complex with the “Breaker-less” system but the risks of implementation and system cost will be much lower when compared to “Breaker-based”. The system of Fig.4(c) is an alternative architecture that utilizes SSCBs of different current rating levels on two buses and may be able to isolate faults using SSCB but with minimal inter-communications. If generators are distributed between buses this architecture provides an opportunity for operation with a high power quality bus on the inside, dedicated to feeding the low voltage systems within the zones under normal conditions and a lower quality bus on the outside that is dedicated to high power loads and pulsed loads. These two buses can operate independently of each other if the SSCBs have reverse current blocking capability. The architecture offers an opportunity for efficiency improvement in the ship by allowing the output bus to operate at a lower voltage than the inner bus when it is not necessary to operate at full propulsion speed.

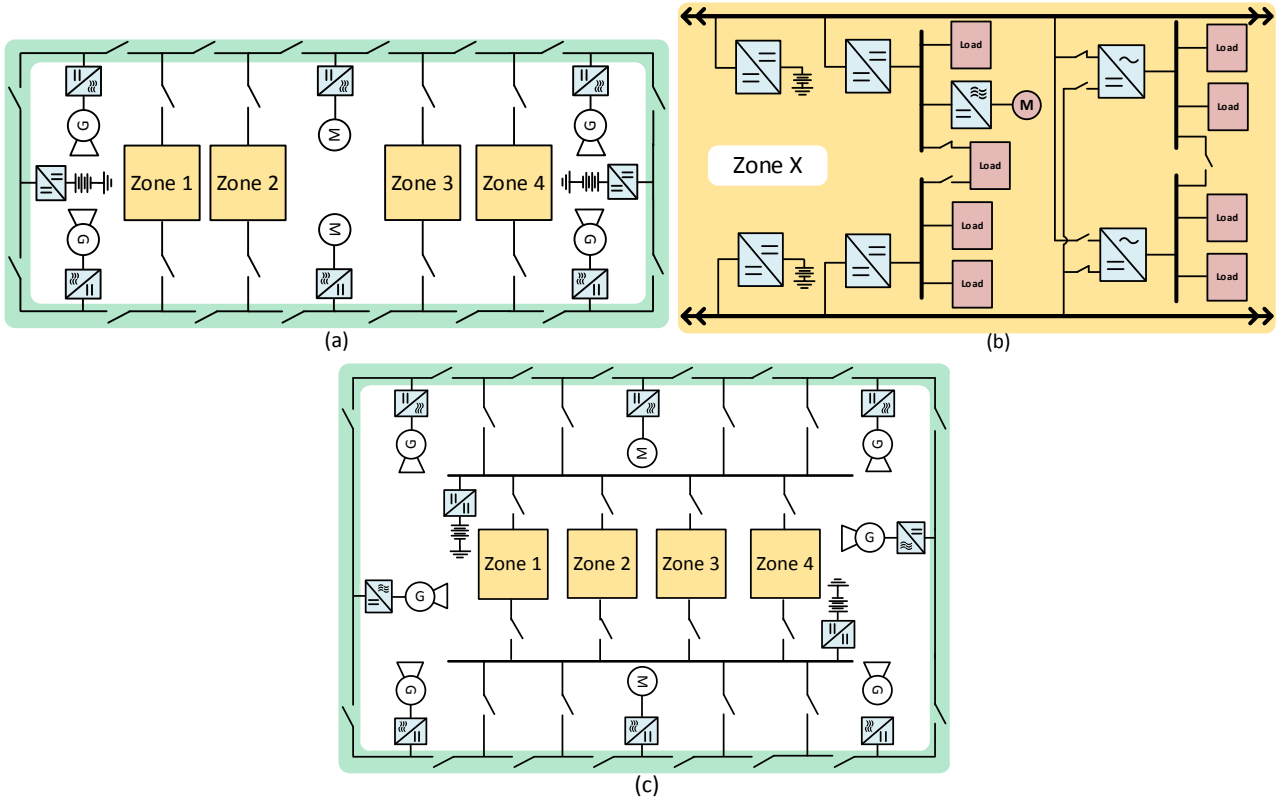

Fig.4 Typical power architectures of ZEDS based dc power distribution systems. (a) DC ZEDS (b) zonal load center (c) dual-ring-bus DC ZEDS

These different power architectures are all feasible choices for the design of onboard dc power system, however, tradeoff always exists between reliability and complexity. Complicated power architectures require much more sophisticated control and coordination strategies, which needs to be carefully evaluated during early-stage design. Generally, the crucial guideline for power architecture design and selection should be on the basis of the reliability and redundancy requirement along with the shipboard mission requirements.

Onboard distributed ESSs: the enabling technology of employing smart grid technologies

Due to the soaring prices of fossil fuels as well as the practical need to integrate intermittent renewables into future energy system, the energy storage technology is one of the hottest research directions in the last decade. With the presence of highly intermittent energy sources and loads, ESSs are necessarily needed in order to guarantee reliability, security, stability and desirable power quality, especially under islanding operation. However, the role of ESSs was seldom concerned in traditional power system. In recent studies, the importance of ESSs in microgrids, especially in islanding ones, is being gradually elevating due to its potential to introduce a range of benefits. ESSs can be directly controlled as the master unit in the microgrid and it, therefore, ensure the uninterrupted operation of the entire system. In addition, the charge-discharge cycle of ESS can be optimally scheduled according to variable energy price, consumption prediction and weather forecast, aiming at achieving economic objectives.

In case of maritime applications, onboard ESSs are taking on a pivotal role in the IPS of next-generation AES. For U.S. Navy surface combatants the main reasons for ESS are twofold: (1) to enhance survivability; (2) To enable high energy pulsed loads. Congressional funding for research and development on AES is motivated by the advent of and need for high impact electric weaponry. Without ESS, the shipboard generators would need to be significantly oversized in order to support the high energy pulsed nature of electric weapons. Even with ESS, the growth of auxiliary loads and the capacity needed to support electric propulsion necessitates a capability to utilize reserve capacity of online generators and ESS in order to “deliver the right amount of power to the right place in the ship at the right time”—which is enabled by IPS.

As for the commercial sector, the fuel economy is the major concern. Considering the fact that diesel generation is still the major power source of all maritime applications, its efficiency characteristic in fixed-speed operation is as shown in Fig.5. In general, engineers will intentionally design and make the diesel generator sets work in their high-efficiency area and modulate the number (K in Fig.5) of running engines in order to achieve optimal load matching. However, instantaneous fluctuations in demand side (e.g. dynamic positioning) will break the balance between power generation and power consumption, and thus reducing the fuel efficiency. The presence of the ESSs can inject bi-directional controllable power flow into the system to achieve load conditioning, such a fact enables modifying fuel efficiency with the help of onboard ESSs. In this way, it is possible for diesel generator sets to work constantly with its modified fuel efficiency.

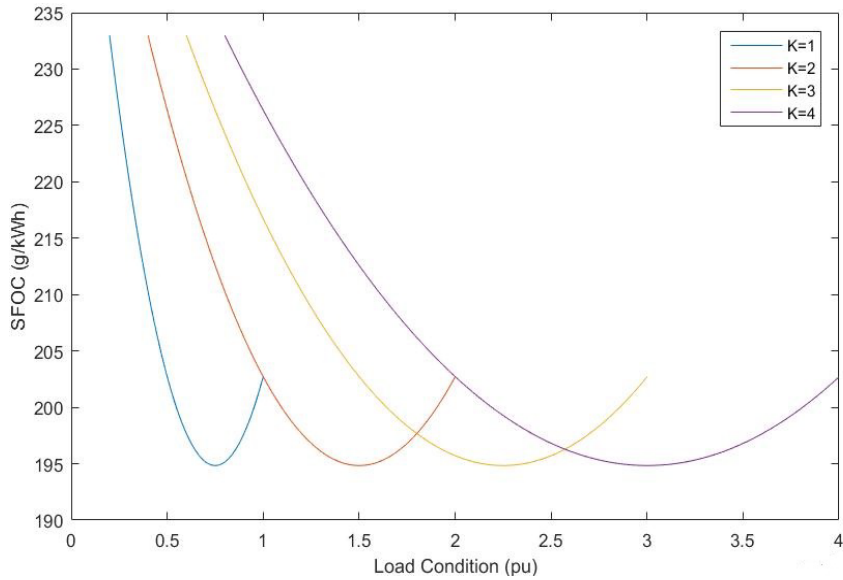

Fig.5 Schematic diagram of fuel efficiency characteristic for diesel generation (in fixed speed)

Along with the development of energy storage devices, there has already appeared a range of commercially available storage device options for stationary or mobile terrestrial applications, a comparison of their instantaneous power density and energy density is shown in Fig.6. Heretofore, batteries, especially lithium-ion batteries, have already become available choice for electric vehicles and hybrid electric vehicles. Electrical double-layer capacitors (EDLCs or informally super capacitors) have been applied for peak power shaving. Flywheels have found application in improving the low-voltage ride through ability for wind farms. Besides that, there are several references involving Na-S battery and superconducting magnetic energy storage (SEMS), even though they have extreme temperature requirements.

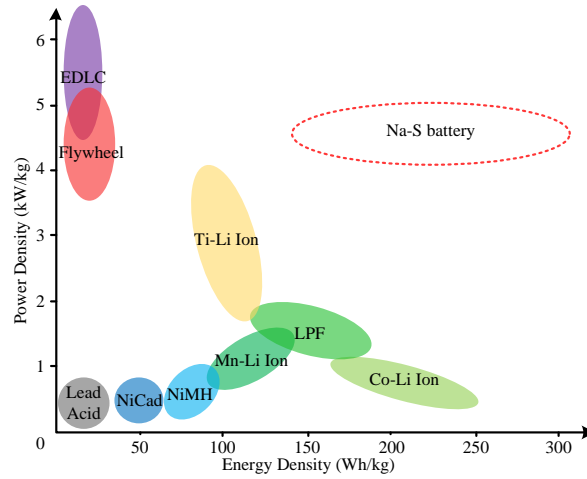

Fig.6 Power density and energy density of different energy storage devices

Since IPS for AES is a large-scaled system with complex loads, one potential solution will be distributed ESSs, which is based on a cluster of large or small ESSs using different kinds of energy storage devices. At present, the most promising dominant energy storage devices for maritime applications are battery, EDLC and flywheel. With proper allocation and configuration, the onboard ESSs will be able to enable multiple functions such as power backup, peak power shaving and braking energy recovery.

From the perspective of control and decision-making, the integration of ESS also introduces a new dimension into control and management of shipboard power system, where efficiency and emission of the onboard generation could be actively optimized. By cooperative control of onboard ESSs and generators under the complex load conditions, the optimization toward lowest fuel consumption and/or least emission, as well as the need to service highly dynamic load demands and pulsed energy requirements, can be achieved simultaneously. Currently, a new trend of installing PV panels and wind turbines onboard a vessel to reduce the cost of sailing is drawing attention from industrials. Such an optimization between ESS and generational sources would be more effective and necessary with the integration of onboard RESs in the near future.

Control and coordination of microgrid based power system

Hierarchical control: the interface to future smart power system

Despite the benefits offered by dc based IPS, it is still a challenging task to achieve voltage regulation in vessel's highly dynamic load condition (especially in dynamic positioning operation) and real-time optimization of fuel economy at the same time. According to IEEE Std 1709-2010, the shipboard dc power system needs to fulfill the following control objectives:

- 1) *Power system stability:* Able to maintain autonomous equilibrium in normal conditions and regain a state of operating equilibrium after being subjected to a physical disturbance.
- 2) *Power quality:* Able to maintain or restore the common dc buses at their nominal voltage with acceptable voltage tolerance.
- 3) *Power management:* Able to optimize systemic efficiency by intentional scheduling or intervention without affecting maximization of power supply to demand side.

In terrestrial applications, dc microgrids are also facing similar challenges, according to IEEE Std 1547 series standards, microgrids should be able to operate both in grid-connected and islanded modes. Power flows are also expected to be managed at the same time. With the active research and development in recent years, a series of advanced control and coordination techniques have been investigated for dc microgrid, one of the most representative ones is hierarchical control scheme, which is an adoption of ISA-95 grid operation

standard in microgrid control. Generally, in order to effectively achieve different control functions, hierarchical control scheme is proposed with following typically defined levels:

- 1) Level 0 (inner control loops): The fundamental control loops to regulate the output voltage and/or current within each power electronic converters connected to the microgrid.
- 2) Level 1 (primary control): The control methods to emulate the physical behaviors that make the system stable and more damped power sharing.
- 3) Level 2 (secondary control): The control methods to ensure the major variables of the system are within the required values.
- 4) Level 3 (initial tertiary control): The control methods to manage and control the power flow among the upper layer grid and/or other microgrids.
- 5) Upper levels (extended tertiary control): The control and decision-making methods to achieve extra targets (practical economic benefits, etc.).

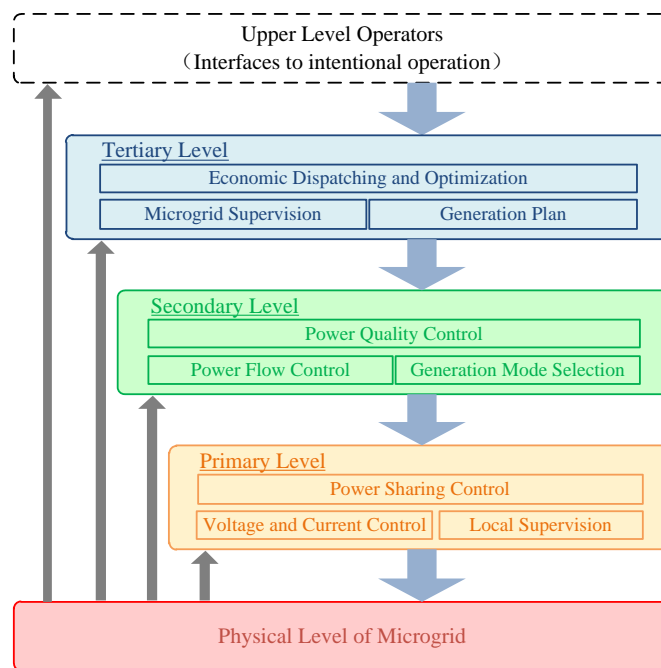

Fig.7 Different control levels in hierarchical control

Fig.7 shows a typical scheme of hierarchical control. At present, mature power electronic converters are designed precisely to ensure that they remain stable and controllable under worst working condition, it therefore allows concentrating on the system-level control like the primary, secondary and tertiary control of the microgrid. Generally, the primary control performs the local control of output voltage and current of the power electronic interfaces following the setting points of the upper control levels. The secondary control that appears above the primary control deals with the voltage or frequency restoration and the management of power quality. Additionally, the secondary control is also in charge of the power exchange with the external grids in the same layer (e.g. other microgrids). The tertiary control is conventionally issued with the task of managing the power exchange with the microgrid and its upper layer grid. In recent studies, there is a trend to integrate the upper control levels which is initially issued to achieve extra targets with in the tertiary control. To this end, the tertiary control is to introduce intelligence to the microgrid and optimize the microgrid operation based on specific interest --normally efficiency and economics.

Fig.8 shows a typical control architecture applying hierarchical control in a generalized dc microgrid. Droop control can be installed as the primary control method for active power sharing purpose. In recent studies, either output power or output current could be selected as the feedback signal in the droop control.

The droop coefficient can be regarded as a virtual internal resistance, in this case, the droop control consists with the physical connection of dc sources and it therefore simplified the design of the parallel converter systems in the dc microgrid. A small voltage deviation will be introduced by droop based primary control, thus, secondary control is introduced to compensate the voltage deviation. In most cases, straightforward PI controller can be employed to meet the need of tracking nominal voltage reference. However, adaptive droop control that uses adaptively changing droop coefficients instead of fixed droop coefficients has also been introduced to some high requirement systems using decentralized coordination. It differs from primary and secondary control, in that the tertiary control is providing optimization functions, thus, not only the controller itself but also decision making methods have been proposed to achieve specific optimization objectives.

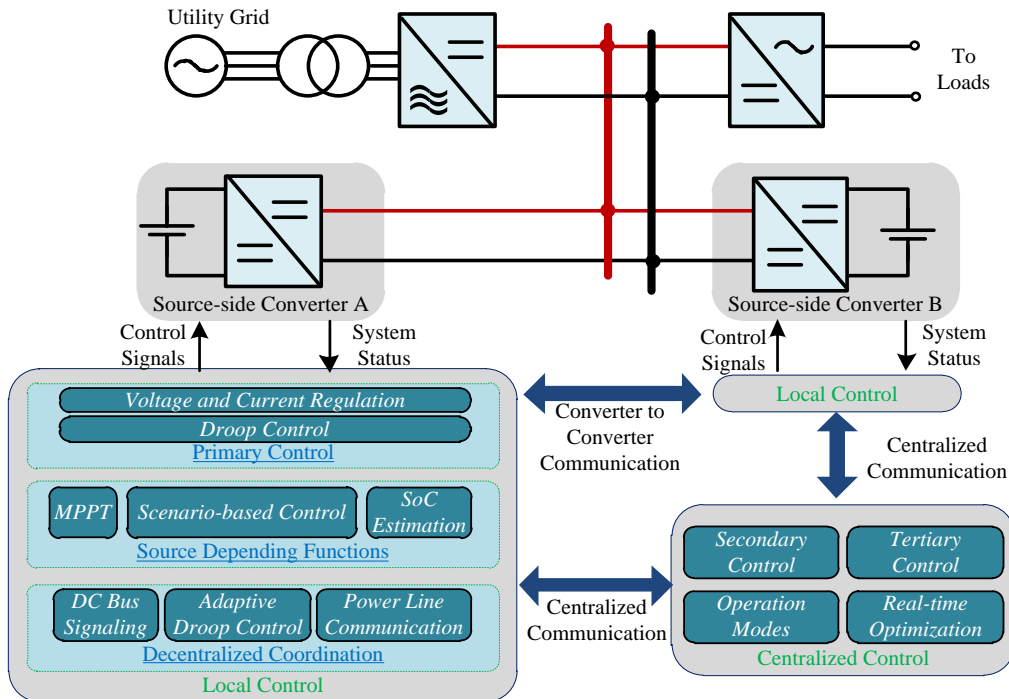

Fig.8 Hierarchical control in practical dc microgrid

Centralized, decentralized or distributed coordination: scenario based choices

For large scale dc microgrids, hierarchical control is often a preferred choice since it offers decoupled behavior between different control layers. However, hierarchical control is achieved by simultaneously using local control of the power electronic interfaces as well as the coordinated control of all these components. The secondary and tertiary control levels are relying on the cooperation of several or all local controllers, for this reason, the coordination in microgrid will also impact on system stability, reliability and performance. According to their different communication modes, coordination methods could be divided into three categories: centralized, decentralized and distributed. Fig.9 shows the different operation principles of these three kinds of coordination methods.

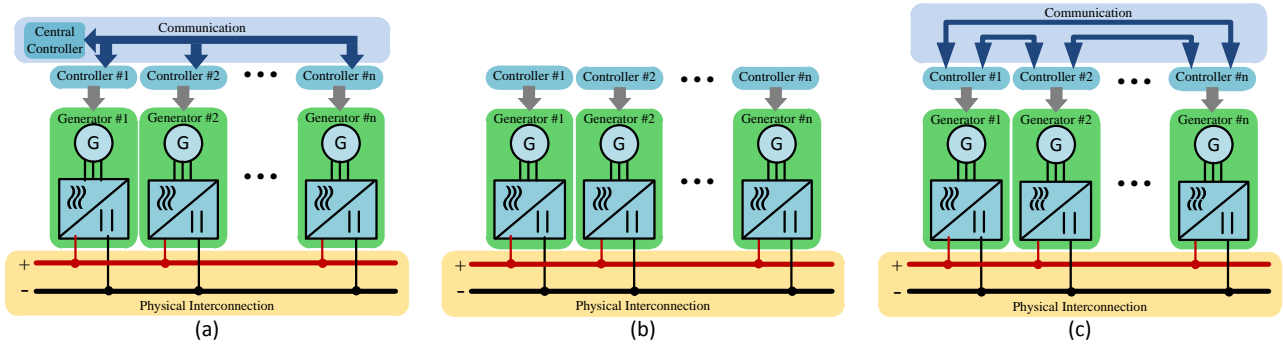

Fig.9 Operating principles of different coordination methods

Centralized coordination control can be implemented in dc microgrids by employing a central controller and a communication network as shown in Fig.9(a). In small scale dc microgrids, each unit can be directly regulated by the central controller via high bandwidth communication using master/slave method. It should be noted that centralized control provides the best foundation for the advanced control functionalities as well as system-level optimization since all relevant data can be collected and processed within a single controller. However, the cost and difficulty to implement centralized control would increase nonlinearly along with the increasing number of accessed components. Moreover, the most obvious drawback is that the control architecture has to face the potential failure of the central controller and/or key communication links, which may block the transmission of the commands and result in a systemic failure. In addition, the emerging issue of cyber-attack is also needed to be considered, especially for some mission-oriented application

Decentralized coordination control is achieved exclusively by the local controllers, as shown in Fig.9(b). The obvious advantage of decentralized coordination is its independency from the communication and central controller, so that this architecture offers higher flexibility and exemption from single point failure. In recent studies, decentralized coordination can be achieved by several methods, such as dc bus signal (DBS) method and power line signal (PLS). These methods are exploiting the information-carrying potential of global variables (i.e. dc bus voltage) in order to achieving coordinated operation. Meanwhile, master/slave control and multi-mode control strategies are commonly used to coordinate the energy sources in order to achieve comparable performance. However, decentralized coordination methods have their own drawbacks, the most important one is the lack of global information awareness, which will result in inherent performance limitation, especially when performing optimization. In addition, the major methods of decentralized coordination based on the response to specific global variables, the accuracy of measurement thus impacts effectiveness of the entire system.

Comparing with the centralized coordination control and decentralized coordination control, distributed coordination is proposed as a compromise, where central controller does not exist but local controllers are able to communicate between each other. The most important distributed coordination method is multi-agent system (MAS) in which each local controller could be regarded as an intelligent agent and all agents compose MAS together. By applying consensus algorithm it could achieve information awareness comparable to that of centralized control and offer possibility to apply wider functionalities than decentralized control. Meanwhile, it keeps comparable reliability with decentralized control. MAS are also considered as an effective way to achieve global optimization objectives, e.g. overall efficiency improvement. However, it requires a complex interaction network among the local controllers and its main limitation is complexity of analytical performance analysis, especially in non-ideal environments, e.g. communication time delays and measurement errors.

Smart grid technologies, the key to smart onboard power system

The common trend of future power systems is moving towards higher intelligence and efficiency. As one of major objectives of future smart grid, intelligent management (e.g. supervisory energy management) and smart protection (e.g. adaptive reconfiguration) concepts, have been introduced to the microgrid as an extension of the conventional hierarchical control architecture. These concepts can also be introduced to IPS in order to achieve efficient and reliable shipboard power system for future smart AES, and therefore contribute to the further improvement of fuel efficiency, limitation of greenhouse gas emission and fault-tolerant ability of the shipboard power system.

Smart coordinated management for lower cost and less emission

In normal conditions, the voyage or mission of a vessel can be divided into several operating scenarios, such as docking, acceleration, deceleration, cruise, etc. These scenarios will not transfer in random order, i.e. the vessel will not dock after acceleration directly. Based on this important fact, pre-planned onboard energy management and its optimization would be applicable to coordinate the onboard generation and ESSs for optimal fuel efficiency. In recent years, International Maritime Organization is making effort in promoting ship energy efficiency management plan (SEEMP) to encourage emission limitation, and it may be required for each vessel in the near future. To design a SEEMP, it is possible to employ advanced offline optimization algorithms to improve the fuel saving effect with reasonable assumptions (i.e. the fuel efficiency is only affected by engine speed and load). However, the practical operation of vessel may have to face innumerable contingencies (e.g. unexpected travel distance due to wind and wave), which make the offline pre-designed SEEMP result in sub-optimal fuel-efficiency. In order to maximize fuel efficiency and/or minimize emission, a potential method is to combine scenario-based multi-mode control and real-time optimization, in which real-time optimizing could be done with the constraints given by tertiary level of hierarchical control (i.e. energy management level) according to detail system status (i.e. overall state of charge information from ESSs and operation mode).

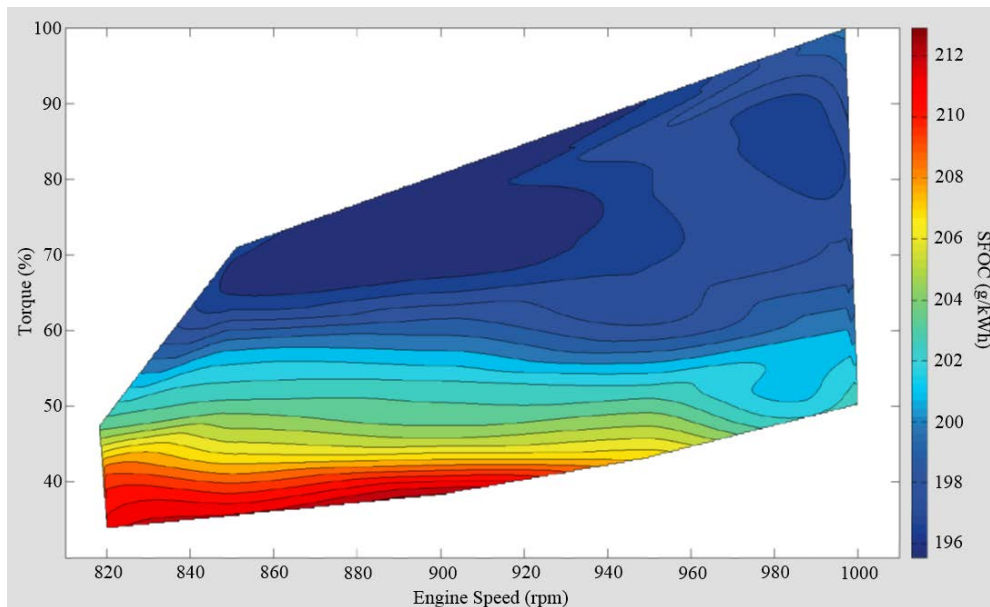

Fig.10 SFOC of typical diesel engine at various speed and torque

In order to implement SEEMP, joint management in both generation side and demand side is required. From the perspective of generation, dc distribution system allows each prime mover operates in variable-speed mode independently without limitation of synchronization. Fig.10 shows an experimental result of the specific fuel oil consumption (SFOC) in g/kWh under the full operating range of a typical shipboard diesel

generator. It indicates that the fuel consumption is a non-linear function to the engine speed and load condition, and it has a high-efficiency area. Generally, the generation-side management tends to keep the onboard generators either working in its high-efficiency area or working in idle speed. In this way, the SFOC should be maintained at its lowest point. However, the onboard generation is not standalone and it always depends on the power demand.

The traditional demand-side management method in power systems is based on load shedding methods. However, the onboard loads are usually mission-oriented and the major energy consumer will be the electric propulsion system in future AES. Thus, the conventional load shedding will result in unwanted performance degradation in mission-oriented function or propulsion system, which makes it unsuitable for such a coordinated management. With the help of ESSs, the dynamic active power balance can be achieved by properly and bi-directionally managing the power flow between ESSs and dc bus. Thus, an equivalent demand-side management can be achieved in this way, which allows highly flexible operation of the other onboard electrical equipment. At the same time, the major optimization objectives such as maximum fuel-efficiency and support of emerging pulsed mission-oriented equipment, can be also achieved.

The role of ESSs in the SEEMP would be extremely important due to its precious bidirectional characteristic. The presence of ESSs breaks the conventional dependency between generation side and demand side, thus significantly improving the maneuverability of SEEMP. In addition, it is noteworthy that the electric propulsion could also act as generation while doing regenerative braking. Traditional method is not able to deal with such kind of bi-directional loads and the excess energy have to be dissipated on dumping resistors in order to keep the stability of the power system. With the help of ESSs, this part of energy can be partly or fully stored, thus, it help reduce the overall cost. One step further, ESSs are also able to take the role of primary energy resource during short-term voyage (e.g. in-port moving) or emergency conditions (i.e. auxiliary generation), which may significantly reduce the environmental impact and enhance the reliability.

Smart protection and reconfiguration for fault-tolerant and highly reliable system

The protection of dc power system, especially those with complex DC ZEDS configuration, is a challenging task requiring the development of SSCBs suitable for MVDC and complex coordination between power converters and protective functions. Moreover, comparing with conventional transformers, instantaneous over-current capability of power electronic converters must be limited in order to avoid equipment damage whereas conventional transformers inherently carry reserve inertia to sudden electrical transient events. As a result, adequate shipboard IPS, which delivers power through power electronic converters, usually leads to overdesign of power electronic equipment. This is a problem given space constraints. Also, considering DC ZEDS, since zones are normally interconnected, there may be scenarios where a single failure may spread and upgrade into regional failure or systemic crash if the protective architecture is not designed to address the potential for such scenarios. Hence, effective fault protection and fault-point isolation are considered as the major challenges for ensuring the safety of MVDC IPS.

A considerable research and development effort has been made to enable the protective function by using power electronic converters. However, there are still several challenging points such as communication delays and measurement failures. In recent studies, measurement failures can be overcome by using outlier data detection and reconstruction algorithms. Expert system concepts have also been introduced into dc microgrid in order to achieve prognosis of fault section and guide the effective protective activities when it occurs.

The reconfiguration capability is one of the most promising advantages of MVDC IPS for future AES, especially for naval applications. However, the non-linear multi-connectivity and high-dimensionality of the

onboard power system make it difficult to achieve fast and efficient reconfiguration. Returning to the DC ZEDS discussion related to Fig.4, several advanced concepts have been introduced to address the protection dilemma. An essential approach is the self-healing reconstruction method, which firstly sub-divides the power system into several zonal microgrids and then reconstructs from microgrids when fault is cleared. The sectionalizing aims at the minimization of the isolated area and maintaining the power supply to healthy zones at the same time. Further, the sectionalized zonal microgrids will attempt to connect with each other and form networked microgrids, which can improve the operation and the reliability. In this way, the power system will recover from the fault in several steps and isolate the fault location at the same time. Fig.11 shows the process of sectionalization and reconfiguration based self-healing when 3 faults occurred in different positions.

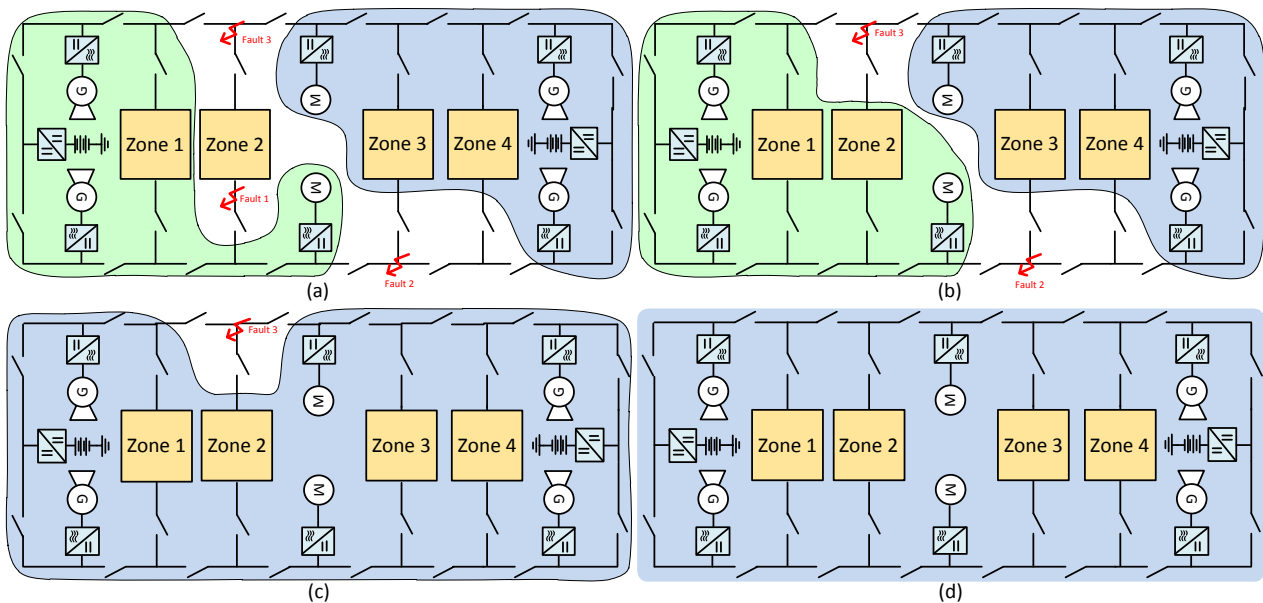

Fig.11 The process of sectionalization and reconfiguration based self-healing method. (a) faults occur; (b) fault 1 clear; (c) fault 2 clear; (d) fault 3 clear.

Conclusion

The article examined dc microgrid based maritime onboard power system and outlined the need as well as the potential benefit of employing both smart grid technologies and MVDC IPS for future AES to enhance the controllability and efficiency of the shipboard power system. A series of technical outcomes from the research of terrestrial dc microgrid have been introduced, such as dc power architecture, application of ESS, hierarchical control, different kinds of coordination methods are briefly reviewed. Combined with the specific need of maritime applications, objective-oriented coordinated management method, as well as protection and reconfiguration in MVDC IPS are also introduced.

In the last decade, there have already been several prototypes of ships in low-voltage dc level, while for MVDC IPS there are still technological challenges and de-risking studies to be performed yet. However, it is foreseeable that the advanced technologies from terrestrial dc microgrid are potentially applicable in MVDC IPS of future AES, and thus, such a combination will contribute to the implement of high-performance MVDC IPS for both commercial and mission-oriented vessels in the near future.

Biographies

Zheming Jin (zhe@et.aau.dk) received his Bachelor and Master degree from Beijing Jiaotong University, China in 2013 and 2015 respectively. He is currently working toward his Ph.D. degree in Department of Energy Technology at Aalborg University, Denmark. His current research interests include dc distribution systems, dc microgrid based power system for mobile applications, and power and energy management of mobile microgrids.

Giorgio Sulligoi (gsulligoi@units.it) earned his M.S. degree (with honors) in electrical engineering from the University of Trieste, Italy, in 2001 and his Ph.D. degree in electrical engineering from the University of Padua, Italy, in 2005. In 2005, he joined MAI Control Systems, Milan, an Italian firm operating in the field of power stations and alternator voltage control systems. He joined the University of Trieste in 2007 as an assistant professor, where he is currently an associate professor as well as the founder and director of the grid-connected & marine Electric Power Generation and Control laboratory at the Department of Engineering and Architecture. His research interests include shipboard power systems, all-electric ships, generator modeling, and voltage control.

Rob Cuzner (cuzner@uwm.edu) is an Assistant Professor at University of Wisconsin-Milwaukee. He was previously a Staff Systems Engineer at DRS Power and Control Technologies where he worked for 20 years on the development of power conversion equipment for Navy Shipboard Integrated Power Systems, electric propulsion and shipboard compatible variable speed drives.

Lexuan Meng (lem@et.aau.dk) received his B.S. degree in electrical engineering and his M.S. degree from the Nanjing University of Aeronautics and Astronautics, Nanjing, China, in 2009 and 2012, respectively. He is currently working as postdoc in power electronic systems at Department of Energy Technology, Aalborg University, Denmark, as a member of the Denmark Microgrids Research Programme. His research interests include the energy management system, secondary and tertiary control for microgrids concerning power-quality regulation, and optimization issues, as well as the applications of distributed control and communication algorithms.

Juan C. Vasquez (juq@et.aau.dk) earned his B.S. degree in electronics engineering from the Autonomous University of Manizales, Colombia, in 2004. In 2009, he received his Ph.D. degree in automatic control, robotics, and computer vision from the Technical University of Catalonia, Barcelona, Spain. In 2011, he joined the Department of Energy Technology, Aalborg University, Denmark, where he works as an associate professor and is coleader of the Microgrid Research Program.

Josep M. Guerrero (joz@et.aau.dk) earned his B.S. degree in telecommunications engineering, his M.S. degree in electronics engineering, and his Ph.D. degree in power electronics from the Technical University of Catalonia, Barcelona, in 1997, 2000, and 2003, respectively. Since 2011, he has been a full professor with the Department of Energy Technology, Aalborg University, Denmark, where he is responsible for the Microgrid Research Program. In 2014 and 2015, he was recognized by Thomson Reuters as a highly cited researcher, and, in 2015, he was elevated as an IEEE Fellow for his contributions in distributed power systems and microgrids.

For Future Reading

Guerrero, J.M.; Vasquez, J.C.; Matas, J.; de Vicuña, L.G.; Castilla, M., "Hierarchical Control of Droop-Controlled AC and DC Microgrids—A General Approach Toward Standardization," in *Industrial Electronics, IEEE Transactions on* , vol.58, no.1, pp.158-172, Jan. 2011

Sulligoi, G.; Tassarolo, A.; Benucci, V.; Trapani, A.M.; Baret, M.; Luise, F., "Shipboard Power Generation: Design and Development of a Medium-Voltage dc Generation System," in *Industry Applications Magazine, IEEE* , vol.19, no.4, pp.47-55, July-Aug. 2013

Cupelli, M.; Ponci, F.; Sulligoi, G.; Vicenzutti, A.; Edrington, C.S.; El-mezyani, T.; Monti, A., "Power Flow Control and Network Stability in an All-Electric Ship," in *Proceedings of the IEEE* , vol.103, no.12, pp.2355-2380, Dec. 2015

Cuzner, R.M.; Esmaili, D.A., "Fault tolerant shipboard MVDC architectures," in *Electrical Systems for Aircraft, Railway, Ship Propulsion and Road Vehicles (ESARS), 2015 International Conference on* , vol., no., pp.1-6, 3-5 March 2015

Hansen, Jan Fredrik, John O. Lindtjørn, Klaus Vanska, and OY ABB. "Onboard DC Grid for enhanced DP operation in ships." In *Dynamic Positioning Conference*, vol. 2011. 2011

McCoy, T.J., "Integrated Power Systems—An Outline of Requirements and Functionalities for Ships," in *Proceedings of the IEEE* , vol.103, no.12, pp.2276-2284, Dec. 2015