



**AALBORG UNIVERSITY**  
DENMARK

**Aalborg Universitet**

## **Robust Droop Control of Grid-Connected Inverters**

Elkayam, Moria; Kuperman, Alon; Guerrero, Josep M.

*Published in:*

Proceedings of International Conference on the Science of Electrical Engineering (ICSEE), 2016

*DOI (link to publication from Publisher):*

[10.1109/ICSEE.2016.7806075](https://doi.org/10.1109/ICSEE.2016.7806075)

*Publication date:*

2016

*Document Version*

Early version, also known as pre-print

[Link to publication from Aalborg University](#)

*Citation for published version (APA):*

Elkayam, M., Kuperman, A., & Guerrero, J. M. (2016). Robust Droop Control of Grid-Connected Inverters. In *Proceedings of International Conference on the Science of Electrical Engineering (ICSEE), 2016* IEEE Press. <https://doi.org/10.1109/ICSEE.2016.7806075>

### **General rights**

Copyright and moral rights for the publications made accessible in the public portal are retained by the authors and/or other copyright owners and it is a condition of accessing publications that users recognise and abide by the legal requirements associated with these rights.

- ? Users may download and print one copy of any publication from the public portal for the purpose of private study or research.
- ? You may not further distribute the material or use it for any profit-making activity or commercial gain
- ? You may freely distribute the URL identifying the publication in the public portal ?

### **Take down policy**

If you believe that this document breaches copyright please contact us at [vbn@aub.aau.dk](mailto:vbn@aub.aau.dk) providing details, and we will remove access to the work immediately and investigate your claim.

# Robust Droop Control of Grid-Connected Inverters

M. Elkayam, A. Kuperman

Dept. of Electrical Engineering and  
Electronics, Ariel University, Ariel  
40700, Israel

A. Belenky

Dept. of Electrical and Computer  
Engineering, Ben Gurion University,  
Beer-Sheva 8410501, Israel

Josep M. Guerrero

Dept. of Energy Technology,  
Aalborg University, Aalborg 9220,  
Denmark [joz@et.aau.dk](mailto:joz@et.aau.dk)

**Abstract** – The use of distributed generation in microgrid systems is becoming a popular way to provide a reliable source of electricity to critical loads. Droop control techniques are used in power systems for the synchronization of grid-connected inverters by local measurements of active and reactive powers. Despite the benefits of distributed generation, the drawback is that large grid-side impedance steps can cause a system to become unstable. A robust control method based on disturbance observer is proposed in this paper. When the proposed robust controller is utilized, closed loop performance remains nearly nominal throughout the whole operation range. Simulation results confirm theoretical issues.

**Keywords** – Droop control, disturbance observer, robust control.

## I. INTRODUCTION

Droop control techniques are widely used in power systems for the synchronization of inverters connected to the grid. This method requires active and reactive power to be measured in order to droop the frequency and voltage accordingly such that the inverter mimics the behavior of a synchronous generator [1]-[5]. However, droop control still has drawback of high dependency on the power line impedances, i.e. the grid impedance and the inverter output impedance. In previous researches, the magnitude of the inverter output impedance is assumed to be smaller than the magnitude of the grid impedance [6]-[8]. However, increasing the inverter side inductance will increase size and cost.

In order to consider the changes in the grid side inductance, robust control approach is proposed in this paper, independent of the system topology thus suitable for any grid-connected inverter system. The method is based on two-degrees-of-freedom control structure [9] and consists of two loops as follows: the inner loop estimates lumped uncertainty and disturbance causing by the inductance changes, causing the system to deviate from nominal plant and cancels it, making the outer loop “see” the nominal plant and regulate it using nominal controller [10], [12]. In order to estimate lumped uncertainty and disturbance, disturbance observer (DOB) approach utilizes appropriately filtered inverse plant model [13], [14].

## II. CONVENTIONAL DROOP CONTROL METHOD

### A. System structure

The grid-connected inverter considered in this paper is shown in Fig. 1, where  $V$  and  $V_0$  are the peak values of the inverter voltage and the grid voltage, respectively,  $\delta$  is the

phase angle of the inverter voltage, and  $i$  is the current which flows from the inverter to the grid through the inductor  $L$ .  $R$  represents a virtual resistance. Moreover, the phase angle of the grid is assumed to be zero.

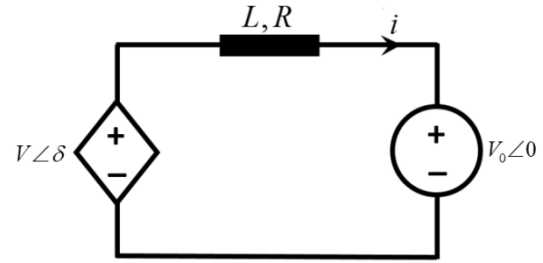

Fig. 1: Circuit diagram of the grid-connected inverter

The inverter voltage and the current defined by the functions

$$v(t) = V \sin(\omega t + \delta) \quad (1)$$

$$i(t) = I \sin(\omega t + \varphi), \quad (2)$$

where  $\varphi$  is the phase angle of the current and  $\omega$  is the inverter frequency in rad/s. Following [11], the virtual active and reactive powers are given by

$$P^* = \frac{V}{Z} [V \cos \theta - V_0 \cos(\delta + \theta)] \quad (3)$$

$$Q^* = \frac{V}{Z} [V \sin \theta - V_0 \sin(\delta + \theta)], \quad (4)$$

where  $Z \angle \theta = R + jX$ , and  $X = \omega L$ .

The transformation  $T(\theta)$  used to define the virtual active and reactive powers

$$\begin{bmatrix} P \\ Q \end{bmatrix} = T(\theta) \begin{bmatrix} P^* \\ Q^* \end{bmatrix} = \begin{bmatrix} \sin \theta & -\cos \theta \\ \cos \theta & \sin \theta \end{bmatrix} \begin{bmatrix} P^* \\ Q^* \end{bmatrix} = \frac{1}{Z} \begin{bmatrix} X & -R \\ R & X \end{bmatrix} \begin{bmatrix} P^* \\ Q^* \end{bmatrix}. \quad (5)$$

Finally, the transformed virtual powers

$$P = \frac{VV_0 \sin \delta}{Z} \quad (6)$$

$$Q = \frac{VV_0 \cos \delta - V_0^2}{Z}. \quad (7)$$

It can be seen that  $P$  and  $Q$  depend simultaneously on the inverter's phase angle, and the difference between the inverter voltage and the grid voltage.

Usually, the angle  $\delta$  and the voltage difference between  $V_0$  and  $V$  are very small, so the active and reactive power can be deduced as follows

$$P = \frac{1}{s} \cdot \frac{V_0^2}{Z} \omega \quad (8)$$

$$\tilde{Q} = \frac{V_0}{Z} \tilde{V}. \quad (9)$$

Then, the conventional droop control is given by

$$\omega = \omega_0 - k_p(P - P_0) \quad (10)$$

$$V = V_0 - k_q(Q - Q_0), \quad (11)$$

where  $\omega_0$  and  $V_0$  are the base frequency and voltage respectively,  $P_0$  and  $Q_0$  are the temporary set points for the real and reactive power, and  $P$  and  $Q$  are the measured averaged real and reactive power values through a notch filter (NF), set to double grid frequency ( $2\omega_0$ ). The use of NF instead of the commonly used low-pass filter with cutoff frequency of  $0.2\omega_0$  (one decade below the double grid frequency), achieves ten times fastest dynamic response of the system because the filter frequency bounds the controller operation frequency to be at least one decade below.

### B. Problem formulation

From (8) and (9), the plant models of the active and reactive powers are

$$P_p(s) = \frac{\tilde{P}}{\tilde{\omega}} = \frac{1}{s} \cdot \frac{V_0^2}{Z} \quad (12)$$

$$P_q(s) = \frac{\tilde{Q}}{\tilde{V}} = \frac{V_0}{Z}. \quad (13)$$

Droop controllers may then be selected as shown in [15]

$$C(s) = \frac{\omega_c}{s} P(s)^{-1}, \quad (14)$$

where  $\omega_c$  is the desired crossover frequency, leading to the “ideal” loop gain  $\omega_c/s$ . However, attaining “ideal” loop gain is a nontrivial challenge since both  $P$  and  $Q$  plants depend heavily on the effect of the power line impedance, particularly the unknown grid side impedance value. Since the plant affected by the line impedance changes, i.e

$$Z_{\min} < Z < Z_{\max}, \quad (15)$$

it can be seen from (14) the influence on the controller stability as well. Hence, the performance of the whole system with controller designed to nominal mode is not guaranteed, because the system doesn't remain nominal. In order to overcome this drawback, some proposals were done by neglecting the grid side impedance by much higher inverter side impedance, which beside the obvious loss of size and cost, also slow down the dynamic response of the system.

## III. DOB BASED CONTROL

In order to consider the changes in the power line impedance, disturbance observer (DOB) based robust control approach is proposed in this paper.

### A. Basic concept of DOB

The DOB is known as an estimator which estimates the

unknown inputs with known information of the control system. The controller consists of two main loops operating as follows: inner (fast) loop estimates lumped uncertainty and disturbance,  $\zeta(s)$ , causing the system to deviate from nominal plant,  $P_N(s)$ , and cancels it, while outer (slow) loop forces the closed loop system to follow desired dynamics (Fig. 2).

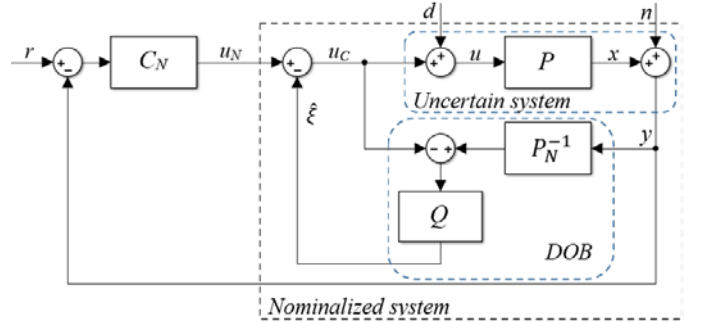

Fig. 2: DOB-based two-degrees-of-freedom feedback control system

Conventionally, the disturbance observer based on the inverse of the system transfer function is called Q-filter approach. The Q-filter is added to make the inverse of the system transfer function proper and filter the measurement noise in high frequencies. The DOB filter transfer function is

$$Q(s) = \frac{1}{\omega_Q^{-1}s + 1} \quad (16)$$

with

$$\omega_Q \gg \omega_c; f_Q \gg f_c. \quad (17)$$

### B. Proposed droop control

According to (14), we can easily design any controller based on the nominal model.

$$C_N(s) = \frac{\omega_c}{s} P_N(s)^{-1} \quad (18)$$

where the nominal plant of the active and reactive power deduced from (12) and (13)

$$P_{P-N}(s) = \frac{1}{s} \cdot \frac{V_0^2}{Z_{nom}} \quad (19)$$

$$P_{Q-N}(s) = \frac{V_0}{Z_{nom}}. \quad (20)$$

Hence, the DOB can reject the input and output disturbances and compensate uncertainties of the plant while the controller still designed by traditional droop control method.

## IV. SIMULATION RESULTS

The circuit diagram of the grid-connected inverter shown in Fig. 1 was used to simulate the effect of the proposed control method. Simulation results are shown in Figs. 3-6. The simulation is repeated with a number of different inductance

values to study the effect of this parameter on the conventional (Figs. 3 and 5) and proposed (Figs. 4 and 6) systems. It can be seen that when utilizing the proposed controller, closed loop performance does remain nearly nominal even at operation extremes. Moreover, the system with DOB controller has relatively fast response settling time with respect to the conventional droop controlled system. All system parameters are given in Table 1.

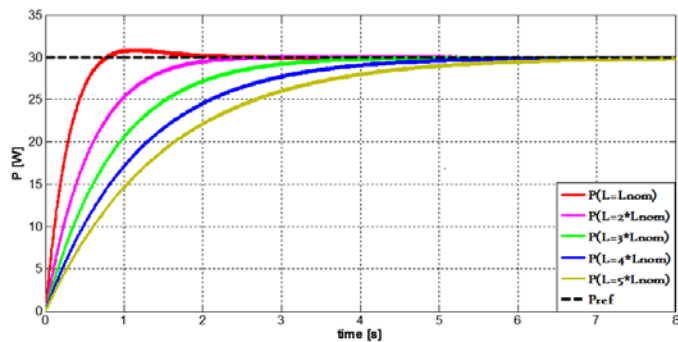

Fig. 3: Dynamic response of the active power with conventional droop control

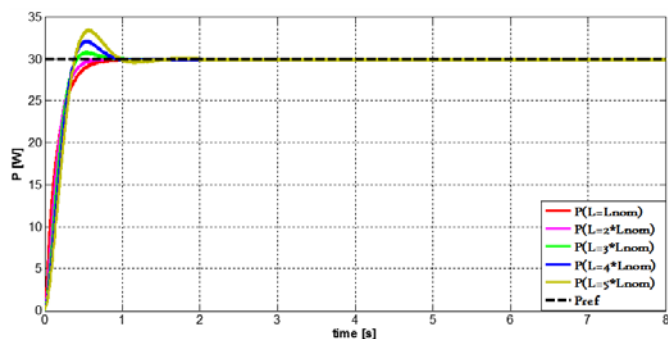

Fig. 4: Dynamic response of the active power with proposed droop control

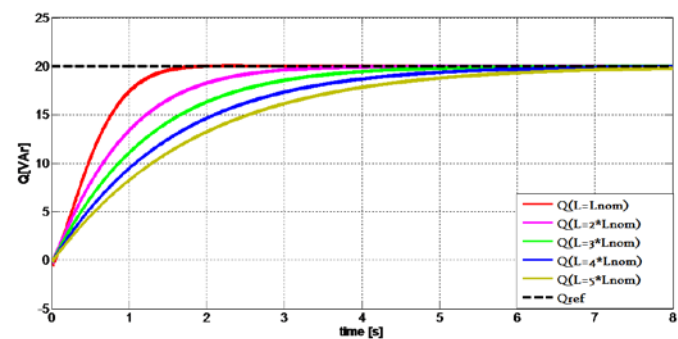

Fig. 5: Dynamic response of the reactive power with conventional droop control

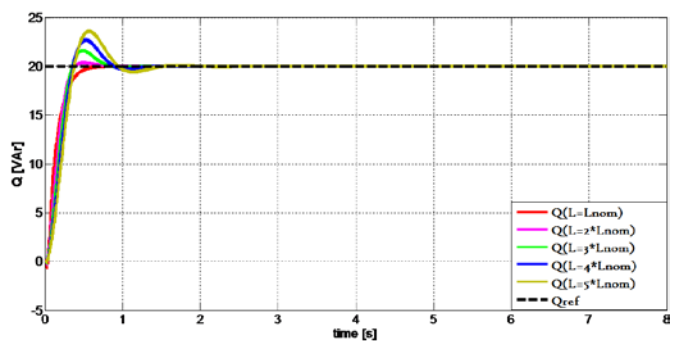

Fig. 6: Dynamic response of the reactive power with proposed droop control

Parameters	Value
$P^*$ [W]	30
$Q^*$ [VAr]	20
$V_0$ [V]	$230\sqrt{2}$
$f_0$ [Hz]	50
$f_k$ [Hz]	10
$f_c$ [Hz]	1
$R$ [ $\Omega$ ]	0.1
$L$ [ $\mu H$ ]	650
$Z_{nom}$ [ $\Omega$ ]	0.2

Table 1: System parameters

## V. CONCLUSIONS

A robust disturbance observer based control approach is presented in this paper, aimed to cancel the effect of changes in the grid side impedance values. Simulation results have shown that typical droop controller, designed according to nominal operating point, fails to maintain nominal performance throughout the whole operation range. Utilizing the proposed controller, closed loop performance does remain nearly nominal even at operation extremes. Moreover, it was demonstrated that the system with DOB controller has relatively fast response settling time.

## REFERENCES

- [1] J. M. Guerrero, J. C. Vasquez, J. Matas, L. G. de Vicuña, and M. Castilla, "Hierarchical Control of Droop-Controlled AC and DC Microgrids — A General Approach Toward Standardization," *IEEE Trans. on Industrial Electronics*, vol. 58, no. 1, pp. 156–172, (2011).
- [2] M. B. Delghavi and A. Yazdani, "An Adaptive Feedforward Compensation for Stability Enhancement in Droop-Controlled Inverter-Based Microgrids," *IEEE Trans. on Power Delivery*, vol. 26, no. 3, pp. 1764–1773, (2011).
- [3] K. D. Brabandere, B. Bolsens, J. van den Keybus, A. Woyte, J. Driesen, and R. Belmans, "A Voltage and Frequency Droop Control Method for Parallel Inverters," *IEEE Trans. on Power Electronics*, vol. 22, no. 4, pp. 1107–1115, (2007).
- [4] J. Kim, J. M. Guerrero, P. Rodriguez, R. Teodorescu, K. Nam, "Mode Adaptive Droop Control With Virtual Output Impedances for an Inverter-Based Flexible AC Microgrid," *IEEE Trans. Ind. Electron.*, vol. 26, no. 3, pp. 689–701, (Mar. 2011).

- [5] J. C. Vasquez, J. M. Guerrero, A. Luna, P. Rodríguez, and R. Teodorescu, "Adaptive Droop Control Applied to Voltage-Source Inverters Operating in Grid-Connected and Islanded Modes," *IEEE Trans. Ind. Electron.*, vol. 56, no. 10, pp. 4088-4096, (Oct. 2009).
- [6] S. M. Sharkh and M. Abu-Sara, "Digital current control of utility connected two-level and three-level PWM voltage source inverters," *European Power Electronic Journal*, vol. 14 No. 4, 2004, pp. 13-18.
- [7] M. A. Abusara and S. M. Sharkh, "Design and Control of a Three-Phase Grid Connected Interleaved Inverter," *IEEE Trans. Power Electron.*, vol. 28, no. 2, pp. 748-764, (Feb. 2013).
- [8] M. Liserre, R. Theodorescu, and F. Blaabjerg, "Stability of photovoltaic and wind turbine grid-connected inverters for a large set of grid impedance values," *IEEE Trans. Power Electron.*, vol. 21, no. 1, pp. 263-272, (Jan. 2006).
- [9] T. Umeno and Y. Hori, "Robust speed control of dc servomotors using modern two-degrees-of-freedom controller design," *IEEE Trans. Ind. Electron.*, vol. 38, no. 5, pp. 363 - 368, (May 1991).
- [10] M. Sitbon, S. Schacham, and A. Kuperman, "Disturbance observerbased voltage regulation of current-mode-boost-converter-interfaced photovoltaic generator," *IEEE Trans. Ind. Electron.*, vol. 62, no. 9, pp. 5776-5785, (Sep. 2015).
- [11] Karimi-Ghartemani, M., "Universal integrated synchronization and control for single-phase DC/AC converters," *Power Electronics, IEEE Transactions on*, vol.30, no.3, pp.1544,1557, (March 2015).
- [12] A. Kuperman, Y. Horen and S. Tapuchi, "Input-output nominalization of linear plants with slow varying uncertainties," *COMPEL – Int. J. Comp. Math. Electr. Electron. Eng.*, vol. 29, vol. 1, pp. 72-89, (2010).
- [13] K. Ohnishi, K. Ohnishi and K. Miyachi, "Torque-speed regulation of dc motor based on load torque estimation," in *Proc. IEEJ IPEC-TOKYO*, vol. 2, pp. 1209 - 1216, (1983).
- [14] K. Ohnishi, M. Shibata and T. Murakami, "Motion control for advanced mechatronics," *IEEE/ASME Trans. Mechatron.*, vol. 1, no. 1, pp. 56 - 67, (Mar. 1996).
- [15] A. Kuperman, "Proportional-resonant current controllers design based on desired transient performance," *IEEE Trans. Power Electron.*, vol. 30, no. 10, pp. 5341 - 5345, (Oct. 2015).