

Xplory Jungle

HENRIETTE BIRCH HANSEN
YUSSEF ABDUL-KARIM
PRODUCT REPORT

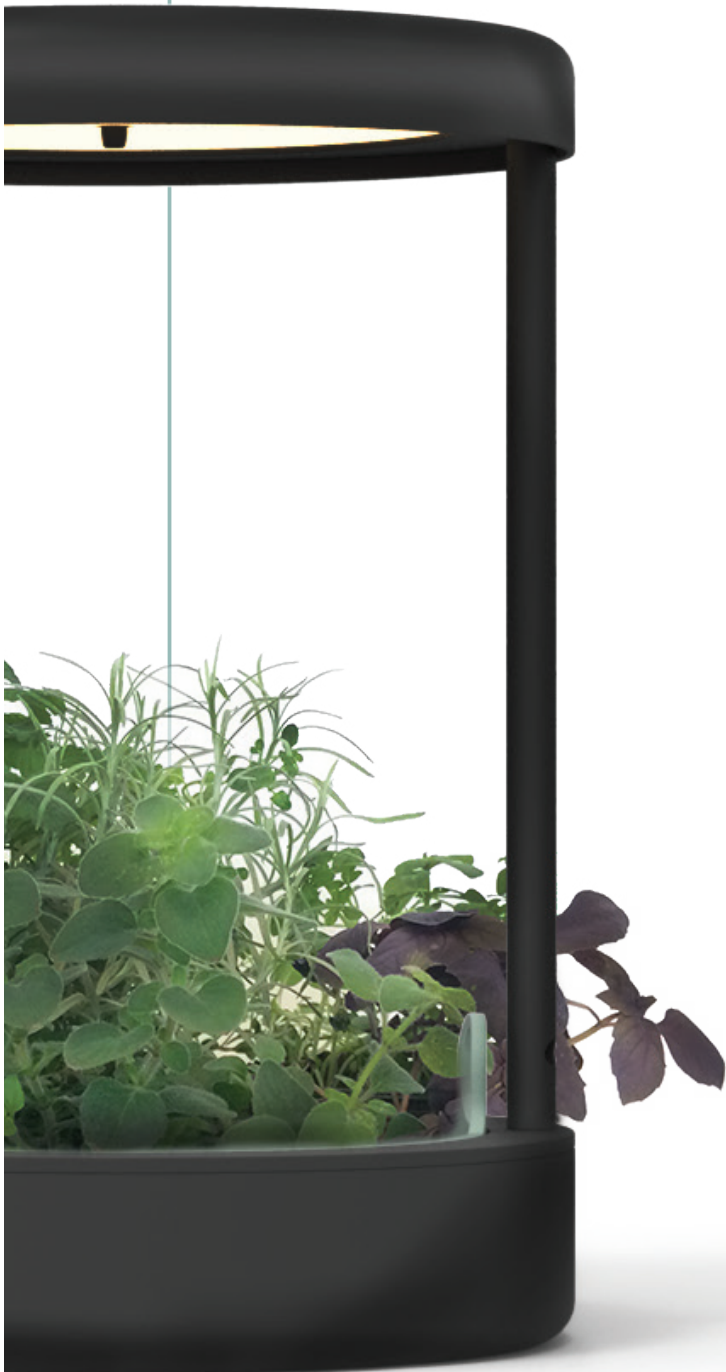

Aalborg University
Industrial Design
Master Thesis
MSc04-ID4
June 2017

Introduction

Xplory a Hydroponic System

This report will take you through the experience and features in Xplory Jungle. Xplory is a hydroponic cultivation system meaning it can grow herbs and leafy vegetables indoor all year around without any soil. The hydroponic technology is used to make family cultivation convenient and independent of seasonal and contextual limitations.

Target Audience

Xplory is developed to meet Danish families, with children in the age of 3-11 year old, needs and desires. Studies about the target audience show there is a great interest in food cultivation. The core motivation factor for the families when it comes to food cultivation is to pass a set of values to their children.

The set of values the parents aspires to pass on is the basic knowledge and skill set to be able to cultivate food. To motivate the family to achieve their cultivation ambitions Xplory is designed to be playful and learning full in use. The overall mission has been to create enjoyable family time while cultivating greens.

Mission

“ Give families enjoyable time together through the experience of growing greens.

Technology Perception

It is interesting to look at hydroponic food cultivation due to the paradigm shift we are facing when it comes to large-scale food cultivation. Even though consumer food moves toward a hydroponic-based production set up the average consumer knows very little about the technology.

This project has therefore been an opportunity to give the families a chance to learn about hydroponic based food cultivation. The focus has been to make hydroponic tangible and more recognizable.

Vision

“ Make tech growing more nature-like.

Project Realization & Collaboration

In order to realize this project Plantui has provided insights and knowledge. Plantui is a Finnish company who sells and produces hydroponic indoor gardens to consumers. Through the development of their portfolio, Plantui has gained great insights about the hydroponic systems and plant variations. Plantui has been seen as a stakeholder and can potential help get Xplory to market.

Xplory Jungle and the World Seed Selection offers another value proposition than Plantui's existing products. Xplory focuses more on making hydroponic cultivation playful, learning full and be family friendly rather than providing a high yield of freshly produced greens. The rest of this report will show you Xplory.

Contents

- 2** Introduction: The Hydroponic Experience
- 4** Creating Family Time With Xplory
- 6** The Xplory Jungle System
- 8** Grow a Jungle & Setup Guide
- 10** Take Care of Your Jungle
- 12** Growth Light & Settings
- 14** Explore & Learn About Plant Cultivation
- 16** Market Potential & Target Price
- 18** Project Cost & Investment
- 20** Business setup
- 22** Assembly & Dimensions

The Design Team



HENRIETTE BIRCH HANSEN



YUSSEF ABDUL-KARIM

Enjoy Xplory with the entire family

Everything you need, to have a joyful cultivation experience

In a busy daily life, it can be hard to find time to connect as a family. Xplory Jungle gives the family the opportunity to put away Ipads and Iphones and create their own small jungle right in the living room.

Designed for families

Xplory Jungle is designed for families and can be used by the little ones as well as adults. Xplory is designed to be durable and fun regardless to age and cultivation skills.

Learn about cultivation in a playful way

Xplory Jungle is made to give the family an enjoyable time together while cultivating greens.

The Xploration Book can help guide and expand the families knowledge about plant cultivation, and continental greens.

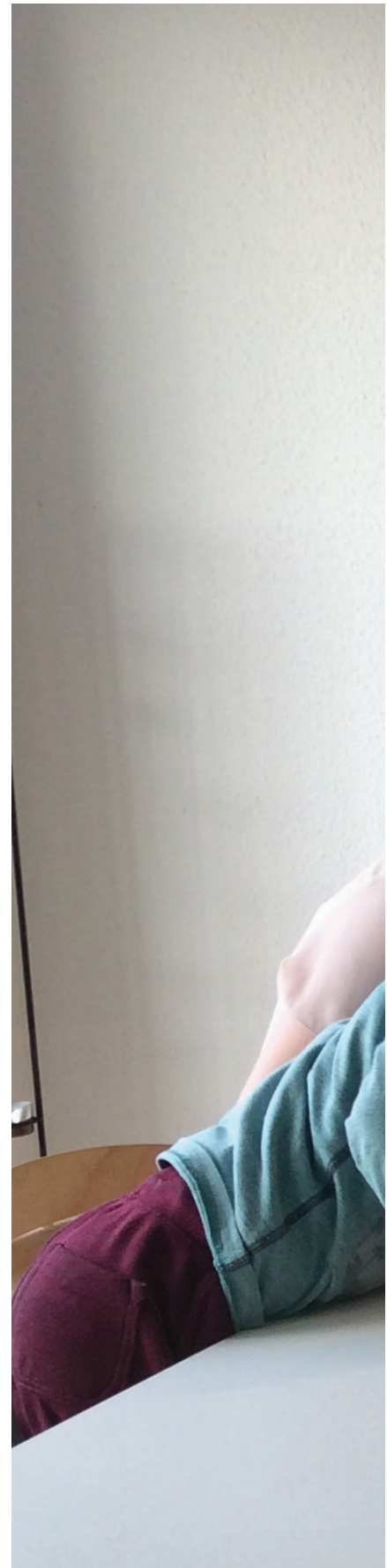



Experience the Xplory system

Everything you need to start your journey

To get the full Xplory experience you need to purchase the Xplory Device and a supplementary seed package, from the World Seed Selection. You can choose between four different destinations which all can be cultivated in your Xplory Device. Get ready to go on a sensory journey around the world.

All you need is..

Xplory Jungle

- 1 Xplory Growth Device
- 1 Xplory Growth Tray
- 1 Xplory Growth Lamp
- 1 Xplory Water Pump
- 1 Setup guide

World Seed Selection

- 1 World Seed Mat
- 5 Unknown Seeds Variants
- 2 Packages of Nutrients
- 1 Nutrient Spoon
- 1 Xploration Book



Southern Europe



pe

Middle East



Scandinavia



South-East Asia



*Where do you
want to go?*

Visit Southern Europe

Spanish, Italian, French?

The Southern Europe seed mat is designed to give you the experience of being in Southern Europe. Remember that time you sat at an Italian restaurant and ate pizza and your senses was evoked with the fresh smell of basil and oregano? The Southern Europe seed mat will take you back or even let you explore new countries.

World Seed Mats

The design of the World Seed Mats gives you an easy and convenient cultivation start. Each seed mat contains five plant variations. The World Seed Mats layout are developed to give a beautiful and wild vegetative pattern. All you have to do is place it in Xplory Device and get started. You can see the setup guide to the right.



Southern Europe seed mat plant combination Red Basil, Curry Plant, Basil Piccoline, Oregano Hot & Spicy and Thyme.

1. Place the seed mat

Take the World Seed Mat and place it in the Xplory Growth Tray. The seeds are incorporated in the mat, ensuring the appropriate distribution of seeds.

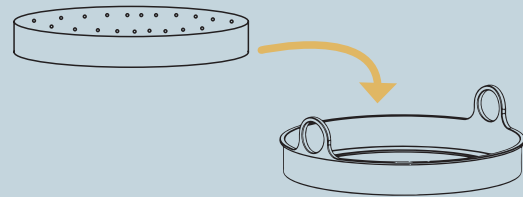

2. Add water & nutrients

Setting up Xplory for the first time it needs 1,5 liter of water mixed with two spoons of nutrients. Shake or stir the mixture and pour it in the water pond. In average watering needs to be done once every week to keep the plants healthy.

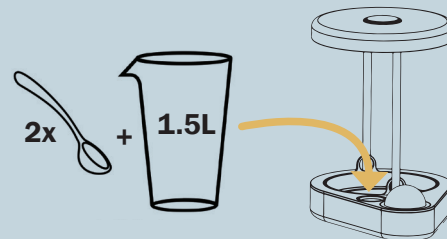

3. Turn it on

To turn on Xplory, plug it into the power outlet and press the on/off button. Xplory will be turned on for 16 hours followed by 8 hours of sleep. The lights turn off to give the plants rest and time to metabolize.

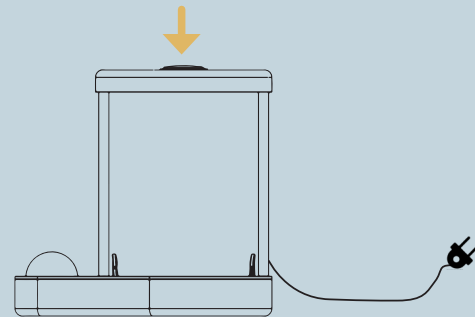

4. Soak it

The World Seed Mat needs to be soaked in water to get the seeds to germinate. Use the pump to soak the mat in water. Using the pump for the first time, it needs to be activated five times before it works.

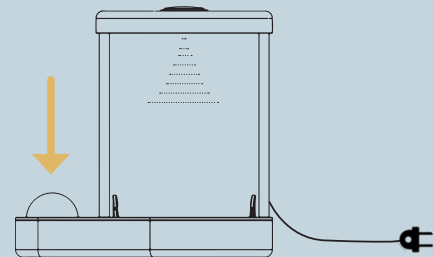

5. Now all you have to do is wait

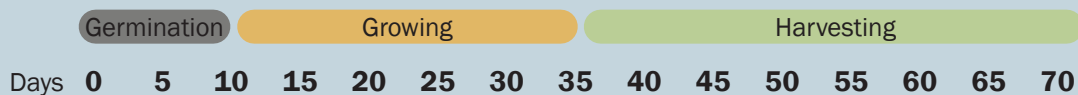

Take care of your Xplory Jungle

You can easily make it rain in Xplory

Xplory has made watering fun, through its Pump & Rain system. All you have to do is pump a few times and Xplory will start to rain on the plants. The Pump & Rain system helps the little ones to learn about ecosystems and plant cultivation in a playful way. Pump away and enjoy the misty rain on your plants.



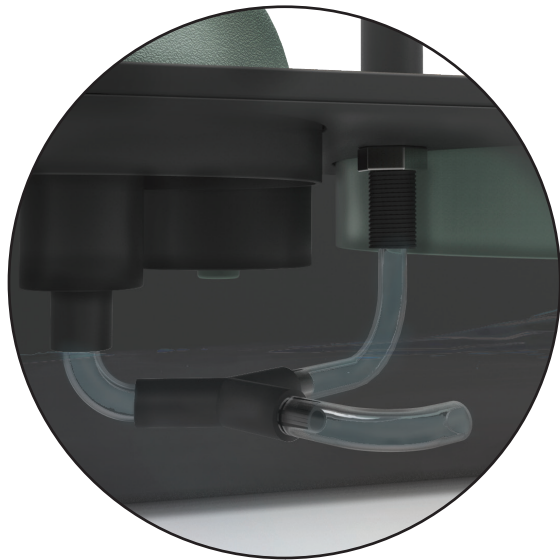

1. Water nozzle

2. Water tube

3. Pump activator

4. Pump & valves

5. Water reservoir

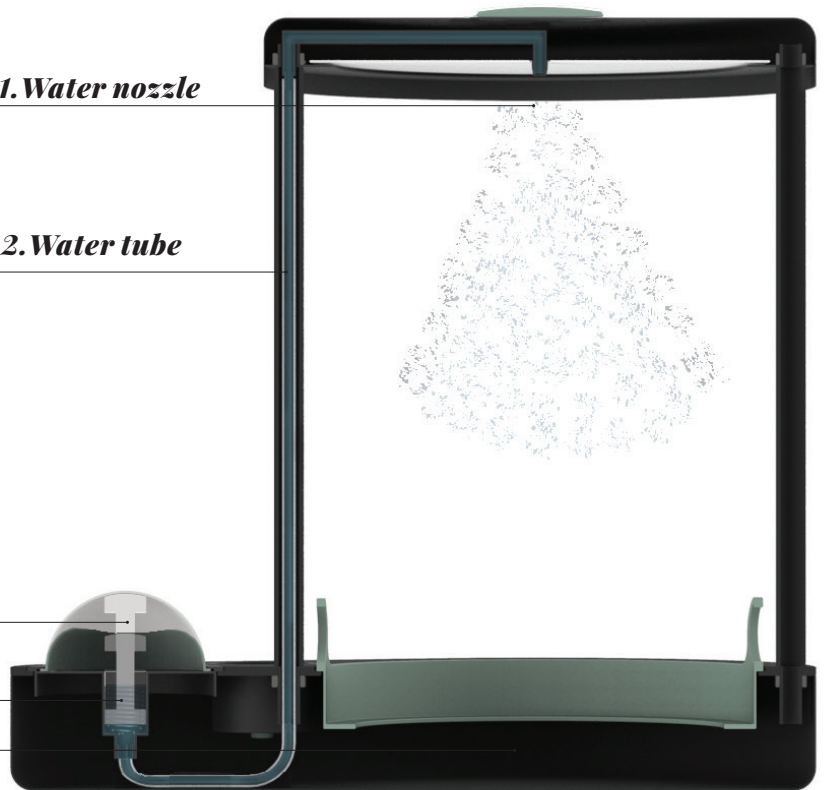

1 The nozzle splits the water into a delicate mist that rains down on the plants. The water keeps the seed mat moist.

2 The water tubes transport water from the reservoir up to the nozzle. The tube and nozzle ensures a watertight system.

3 The rain activates when adding pressure to the ball pump. The ball pump has a spring ensuring the ball handle to get back in position after activation.

4 The pump has two opposing backflow valves to ensure correct water flow direction. Activating the pump generates pressure. This pressure sucks water from the reservoir into the tube.

5 The water reservoirs design allows the plants roots to be in contact with water. The reservoir contains 1,5 liter of water when fully filled. The reservoir needs refill every week or every other week depending on the plants growth stage.

Watering

Xplory's water pond indicates when it is time for watering. The floater in the pond will sink according to the water levels. When filled it will float to the top.

To water Xplory all you need is a bottle or water can. Mix water and nutrient in the water can and pour it into the pond.



Did you know plants needs to sleep?

Plants need to sleep, just like humans. The plants metabolize and recover when the light is turned off. Xplory Jungle is designed to have a 16/8 ratio, meaning the lights are on for 16 hours each day and turned off for 8 hours.

Light settings

Xplory uses Plantui's developed and patented growth light settings, with a few alterations. Plantui's current products are adjusting the height of the lights according to the plant's growth phase.

In the process of developing Xplory's light settings, testing has been conducted. The test shows plant growth can be maintained with a fixated light height. The light is 300 mm above the plant tray at all times in Xplory.

The Xplory light system consists of three light stations. Each light station consists of three LED's one red, one green and one blue.

Xplory Jungle light settings are:

- Red 100 μmol
- Blue 150 μmol
- Green 60 μmol

Germination

Mainly heat and water are needed in the germination phase. The heat comes from the room temperature, being between 20-26°C degrees. The growth light is on during the germination to ensure the perfect sprout conditions from the moment the first leafs are developed.

Growing

The light plays a big role in order to achieve photosynthesis. When the seedlings start to sprout the leafs absorb energy from the growth light, which ensures the process of photosynthesis

Harvesting

In the harvesting stage, the main purpose of the growth lights is to maintain a healthy plant. Furthermore, the plants will keep growing if harvested regularly, the light will ensure this process.

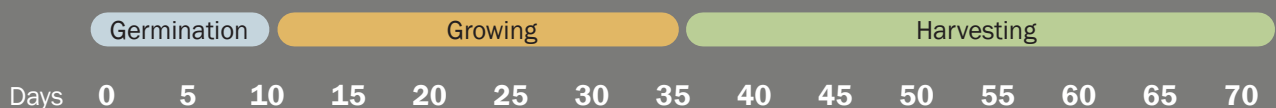

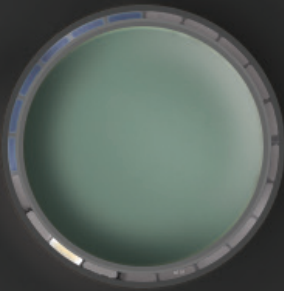

Xplory Jungle is featured with a button, giving you the ability to interact with the plant's sleep cycle. A LED circle-displays indicates the 16/8 ratio by illuminating the current state in the cycle. The system is set up to automatically follow the cycle when turned on.

As a part of the learning experience, about plant cultivation, the light illuminates more intense, when closing in on the 16-hour mark, informing you, that it is time for the plants to sleep. The cycle can be controlled manually by pushing the button, during this you have the possibility to control the cycle.



Explore & Learn

Xploration Book

When you pick out one of the packages from the World Seed Selection, you get a small information book. The book will guide and help you to get the best experience with your Xplory as possible. Below a short overview of the Xploration books content can be viewed.

Contents

- *Get started & take care of your plants*
- *Learn more about your plants*
- *Explore and sense your plants*
- *Identify – what have you cultivated*
- *Harvest and cooking tricks*



Learn about plants

In the Xploration Book, you will find basic cultivation information and fun facts about plants.

This section in the book will help to refresh your knowledge about plants and at the same time teach the family the basics of food cultivation.

Light

Photosynthesis process happens and makes the plants grow.

Nutrients

Plants do not eat food instead, they need nutrients to grow big and healthy. The nutrients are absorbed through the roots.

Water

All living things needs water to exist, the same goes for plants. Remember to water your plants to keep them healthy.

Sleep

Plants needs to sleep just like humans to recover and metabolize.

CO₂

To generate photosynthesis plants need CO₂. They get it from the air in your house. The plants exhale oxygen, which actually improves the climate in your home.

Heat

The plants germinates and thrive in temperature between 20-26°C degrees.

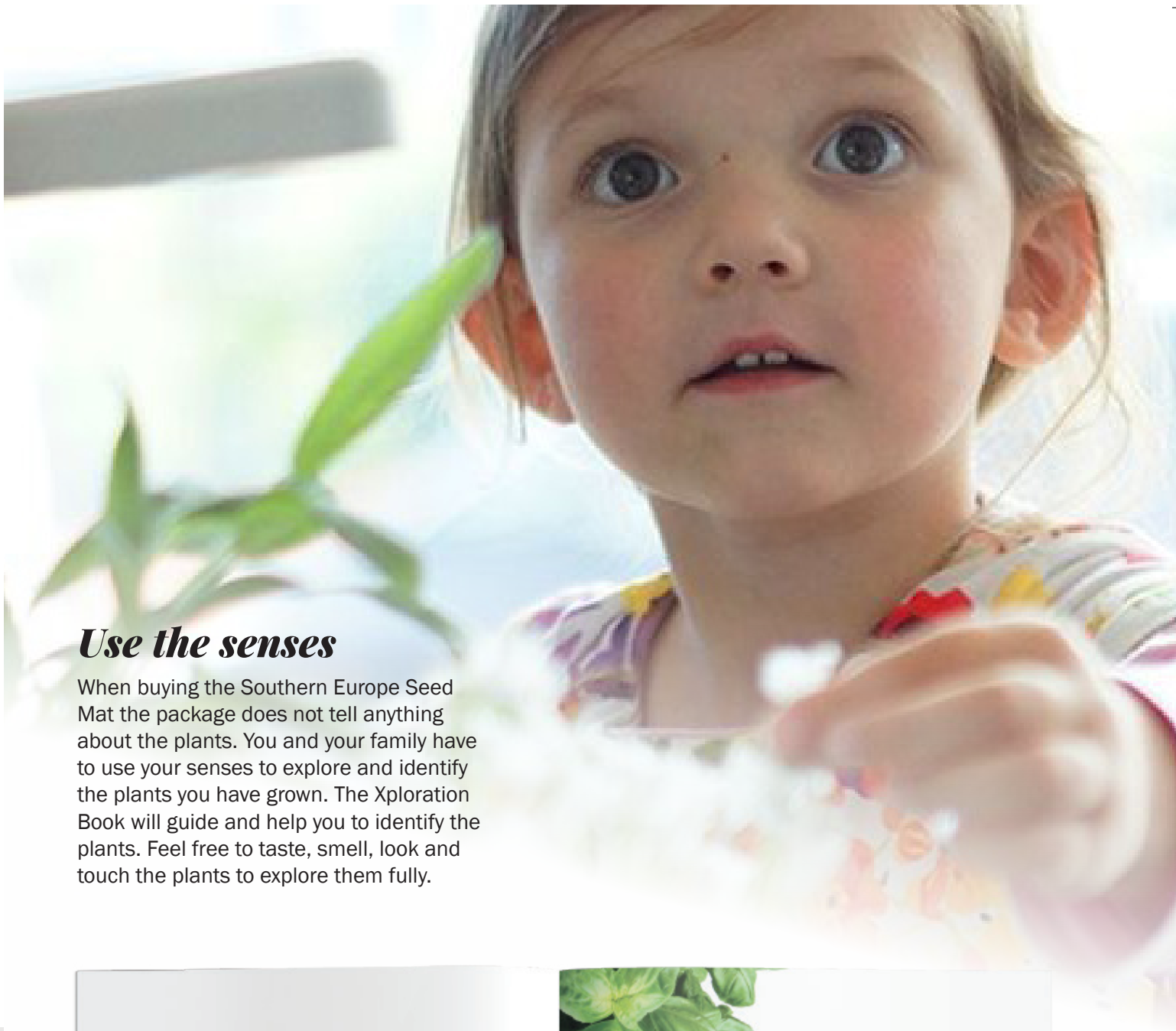

Use the senses

When buying the Southern Europe Seed Mat the package does not tell anything about the plants. You and your family have to use your senses to explore and identify the plants you have grown. The Xploration Book will guide and help you to identify the plants. Feel free to taste, smell, look and touch the plants to explore them fully.

Germination:
The seed starts to sprout, and takes the journey from seed to leafy plant...

Days 0 5 10 15 20 25 30 35 40 45 50 55 60 65 70

Germination Growing Harvesting

Now it is growing!
Can you identify the leaves?

The image shows an open book with two pages. The left page is titled 'Germination:' and features a diagram of a seed sprouting over a 70-day period. The diagram is divided into three phases: Germination (Days 0-10), Growing (Days 10-50), and Harvesting (Days 50-70). The right page is titled 'Now it is growing!' and 'Can you identify the leaves?'. It shows a cluster of green basil leaves at the top left. Below the text are five small green squares, each with a different leaf shape underneath: a simple leaf, a four-lobed leaf, a long serrated leaf, a trifoliate leaf, and a fern-like leaf.

Target Audience

FAMILY HVIID

MOTHER	CAMILLA, 38
FATHER	JOHAN, 38
SON	OLIVER, 6
SON	LUCAS, 4
DAUGHTER	ASTRID, 1
<hr/>	
CALLS THEM SELF	URBANITE'S
LIVES IN	APARTMENT
OUTDOOR SPACE	NON
LOCATION	DENMARK
<hr/>	
DISPOSABLE MONTHLY INCOME	53700 EUR IN AVERAGE
<hr/>	
WILLING TO PAY FOR PRODUCT	60-80 EUR DEPENDING ON OFFERING
<hr/>	
CULTIVATION TYPE	BEGINNER

Only tried to cultivate a few tomatoes in living room window. It did not go well, nobody knows why.



Family Motivators

Child friendly
Easy to maintain
Playful
Everyone can be a part of it
Benefits the children's and parents learning and health

Product questions

How does it work?
Can our children do it?
How much time will it take?
Is it healthy?
How much does it cost?
Can it fit into our home?

Expected Sales

It is estimated that there are around 800000 families with children in Denmark. It is roughly estimated that a direct marketing campaign will successfully reach out to 0.6 percent of these within the first introduction year. These 5000 families are estimated to buy in on at least two World Seed Selections.

It is expected to see a gradual increase the following years. These estimations are based on the Danish market, and not all of the 18 countries Plantui are operating in, thereby leaving a great business potential.

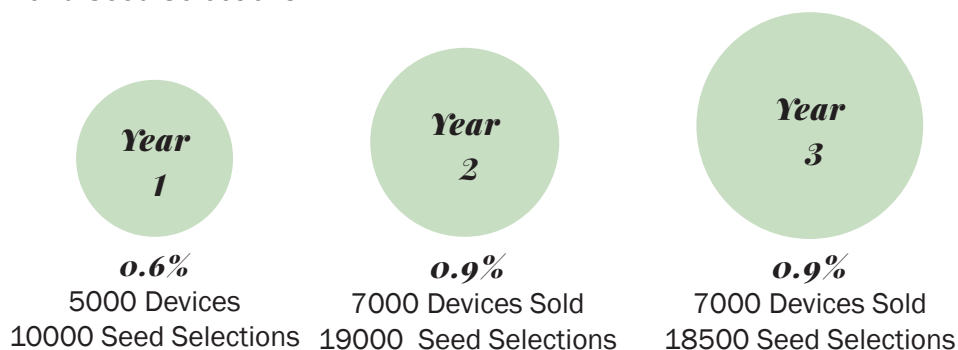

Target Price & Sales

Xplory Jungle
Target price incl. VAT
100 EUR



World Seed Selection
Target price incl. VAT
25 EUR



Sales Channels

Plantui is currently represented in 18 countries all over the world. And working towards entering the American market during 2017, adding a new market of great potential. It is expected that Xplory

will be sold through the Plantui's established sales channel, which in Denmark are big stores such as Coop.dk and Bahne.



Further Development

Introduction

The following pages gives an overview of the further product development and the relating costs. The objective of the following pages is to ensure Xplory and the World Seed Selection mats can maintain a healthy business for Plantui.

Project Road-map

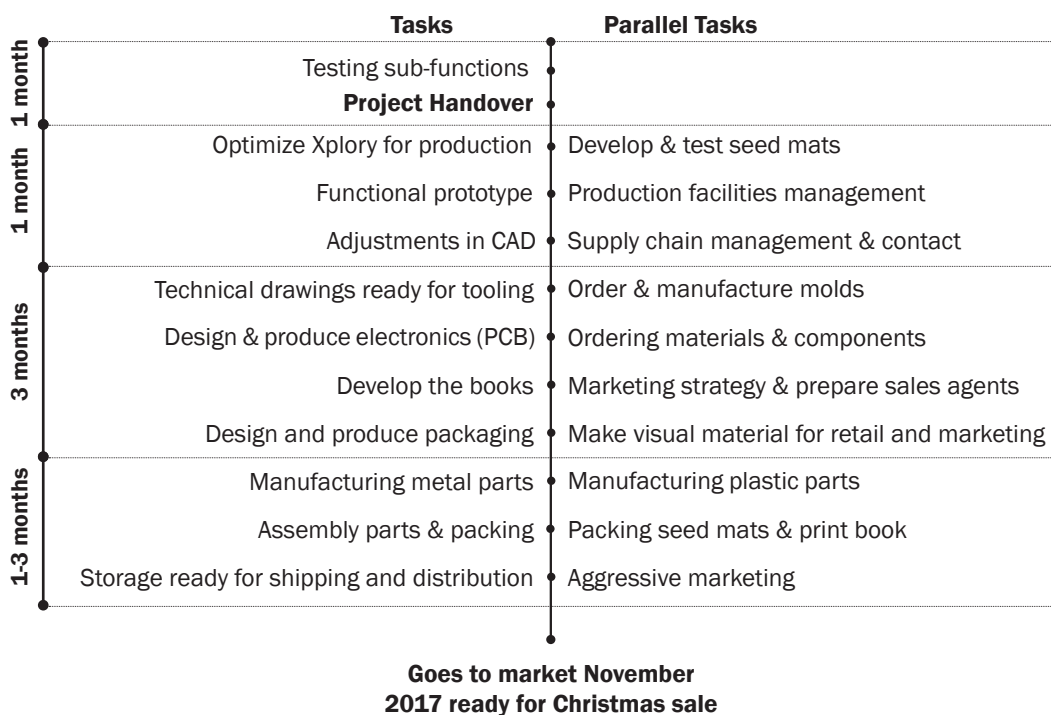

Investment

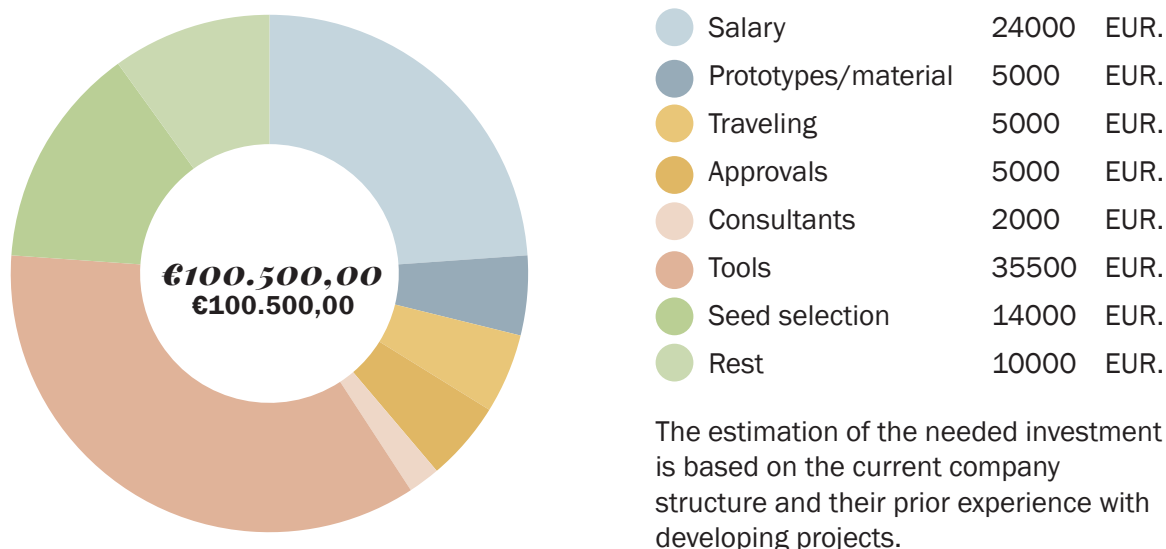

Price Estimation

At the current stage in the development, the production price of the Xplory Device is estimated to be 36 EUR (Worksheet 55). Market survey based on the target audience shows a target price at 100 EUR is acceptable. This rough estimation shows

that this will result in a low contribution of 25% on the devices. However, the low contribution on the Xplory Jungle Device will be counterbalanced by the high contribution of 70% on the World Seed Selection.

XPLORY JUNGLE				WORLD SEED SELECTION			
Price (retail incl. VAT)		100	EUR.	Price (retail incl. VAT)		25	EUR.
Vat	25 %	20	EUR.	Vat	25 %	5	EUR.
Sales price (retail excl. VAT)		80	EUR.	Sales price (retail excl. VAT)		20	EUR.
Contribution, retail store	50%	32	EUR.	Contribution, retail store	50%	10	EUR.
Sales price, PLANTUI		48	EUR.	Sales price, PLANTUI		10	EUR.
Contribution, PLANTUI	25%	12	EUR.	Contribution, PLANTUI	70%	7	EUR.
Production cost	75%	36	EUR.	Production cost	30%	3	EUR.

Break-even analysis

The break-even analysis below shows the estimated break-even point will occur 24 months after the project launch, resulting in an ROI of 589%, (591.707 EUR.). As illustrated in the graph

below, the main profit will be made on the World Seed Selection, resulted in the low operating cost, giving a high operating profit.

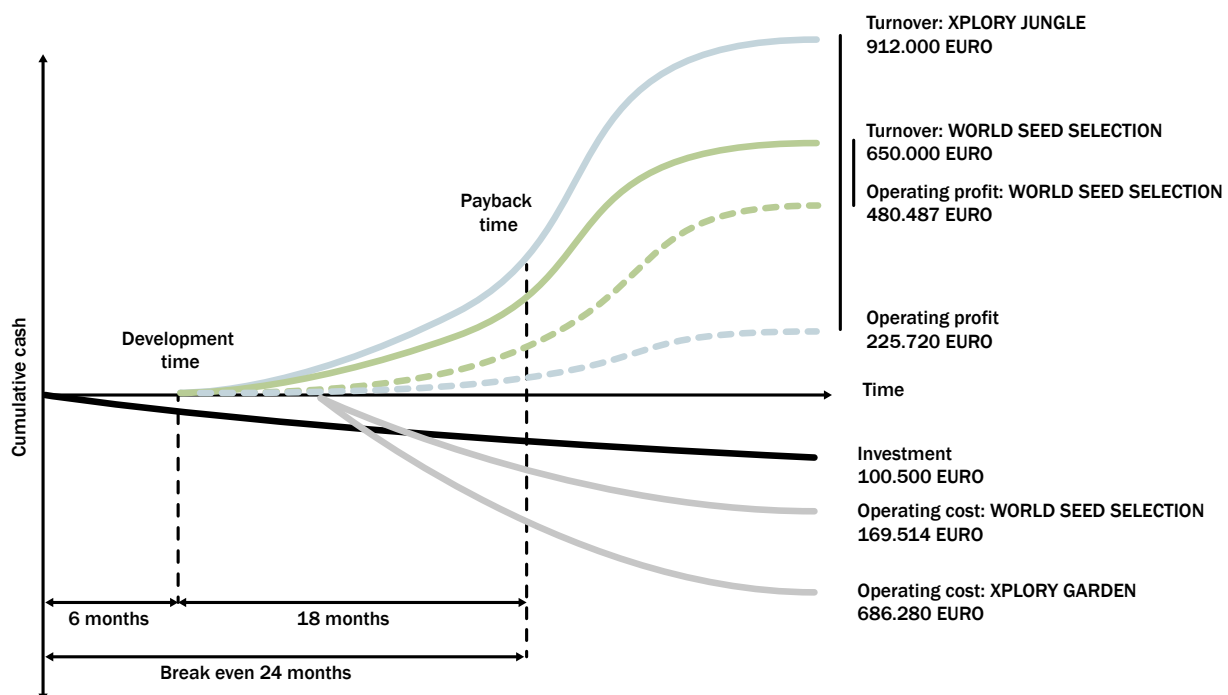

Business Model Influence

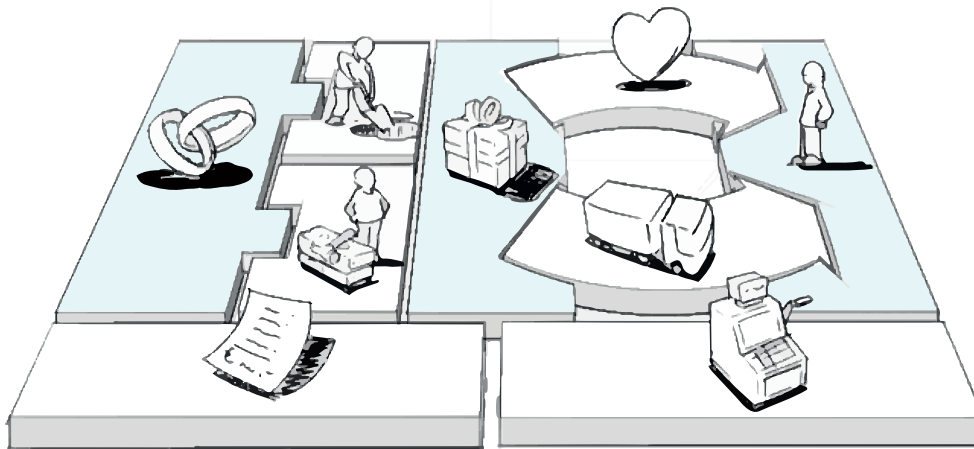

Supply chain

The implementation of the Xplory Jungle will have a minimal influence on Plantui's current business model. The majority of the components used in Xplory Jungle are well known by Plantui and their current supply chain. The pump system and related parts have to be obtained from a new supplier.

Value proposition

Xplory Jungle is designed with families in mind. In comparison with the current portfolio, the focus is on learning and passing on a set of values, instead of achieving a high yield. Even though it is a different value offering, it still goes hand in hand with their current slogan 'Everyone deserves a garden'.

Customer segment

Xplory Jungle is primarily targeting families with children but is also aesthetically addressing the trend-conscious consumer. The investigation of the target audience also showed an interest from the B2G market. Schools, kindergartens, and rehabilitation centers are interested in purchasing Xplory.

Key numbers sum up



Target Price



Investment



Breakeven time



Return of Investment

Scaling Potential

The Xplory Jungle and the World Seed Selection has great potential to evolve and in order to generate sales and keep the customers interested. The World Seed Selection portfolio can be expanded to let the customers explore even more destinations. Xplory is designed for families but already now schools, kindergartens, and students from universities has shown great interest in Xplory.

*The possibilities are endless
expand the World Seed Selection*



Assembly

This section gives an overview of the materials and assembly methods used in Xplory. Xplory Jungle still needs more iterations to be ready for production, but the following is a proposal for a potential construction.

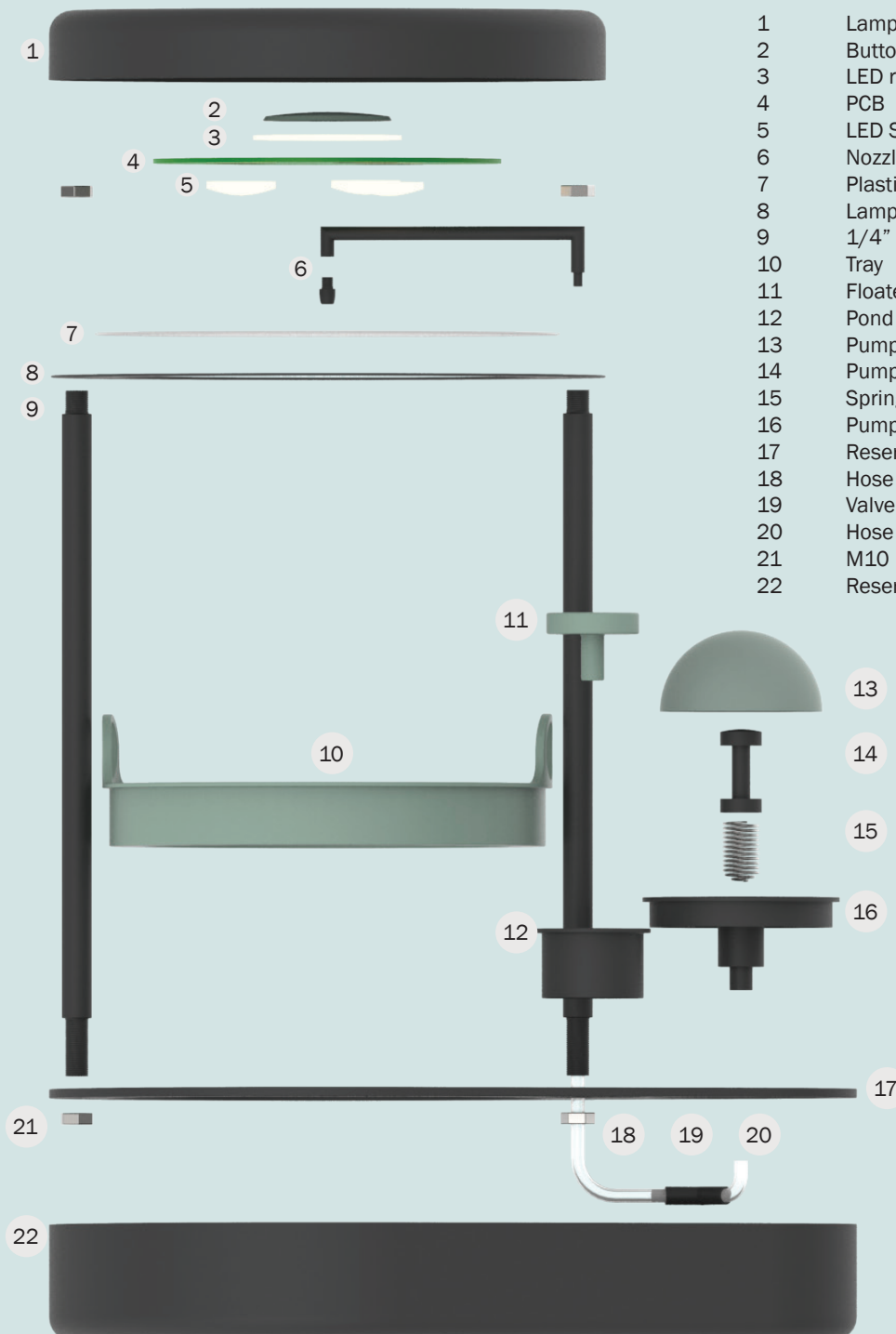

No.	Name	Material	Qty.
1	Lamp top	AISI-316	1
2	Button	ABS	1
3	LED ring	STD	1
4	PCB	STD	1
5	LED Spreader	STD	3
6	Nozzle	ABS	1
7	Plastic screen	PET	1
8	Lamp bottom	AISI-316	1
9	1/4" tubes	AISI-316	2
10	Tray	ABS	1
11	Floater	ABS	1
12	Pond	ABS	1
13	Pump top	N. RUBBER	1
14	Pump activator	ABS	1
15	Spring	SPRING STEEL	1
16	Pump base	ABS	1
17	Reservoir top	AISI-316	1
18	Hose - long	PVC	1
19	Valve	ABS	1
20	Hose - short	PVC	2
21	M10 bolt	AISI-316	4
22	Reservoir	AISI-316	1

Dimensions

Drawing is not in scale - please see the folder with Technical Drawings for more information.

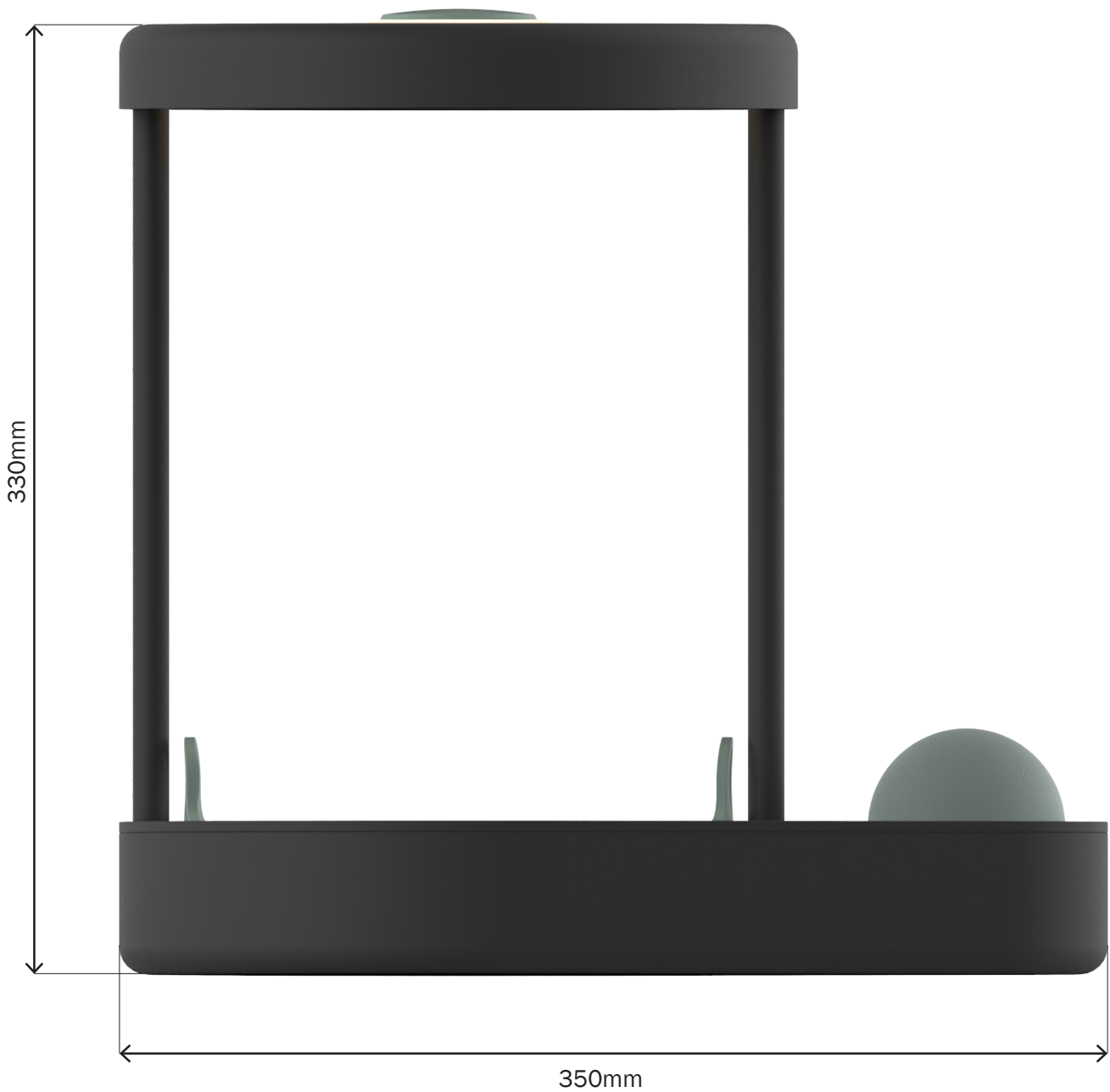



Plantui

Xplory Jungle

HENRIETTE BIRCH HANSEN

YUSSEF ABDUL-KARIM

PROCESS REPORT



**Aalborg University
Industrial Design
Master Thesis
MSc04-ID4
June 2017**

Titlepage

Title Xplory Jungle
Field of study Industrial Design
Project module Master's thesis
Theme Tech based cultivation

Project period 01.02.17-18.05.17
Project team MA4-ID4
Supervisor Christian Tollestrup
Technical supervisor Erik Appel

Pages 72 incl. Formalities
Keystrokes 142.939
Worksheets 55 Worksheets
Editions 6

Acknowledgement

This project could not be done without the families who volunteered to be a part of the various user studies and tests.

Plantui who provided insight, guidance and products for tests and experiments.

Supervisors who has guided us, asked critical question and last but not least pushed us to reflect and improve the project continuously.

Thank you all!

Abstract

Denne rapport undersøger om hydroponisk dyrkning kan implementeres i de danske børnefamiliers hverdag, som et redskab til at bringe familien tættere sammen. Dette projekt er bygget på en bruger baseret tilgang, til at udvikle et hydroponisk system, som opfylder familiernes behov og ønsker.

Den indledende research har vist at forbruger generelt er skeptiske overfor hydroponisk dyrket mad og er usikre på om kvaliteten er god. Derfor undersøger denne rapport hvilke parametre, som kan ændres i det hydroponiske system, for at gøre teknologi baseret dyrkning mere naturligt.

En kombination af research, idegenerering og test af koncepter har verificeret at familierne

ønsker et hydroponisk system som børn såvel som voksne må interagere med. Systemet skal facilitere læring og indsigt i dyrknings processen og fokuserer på planterne frem for teknologien.

Udfaldet af disse undersøgelser er et system bestående af Xplory Jungle og World Seed Selection.

Xplory Jungle er et hydroponisk dyrknings device som sørger for at familierne kan opleve plantedyrkning helt tæt på. World Seed Selections er en række frøpakker, som muliggøre at familierne kan opdage og opleve en bred variation af planter.

Xplorysystemet imødekommer til dels familiernes behov og ønsker, dog er der delelement af løsningen, som på nuværende stadie mangler yderligere tests for at kunne verificere hvorvidt Xplory lever op til alle familiens krav.

Reading guide

This project is documented in two reports. Additionally, an appendix with worksheets and technical drawings are attached.

Process report: Reveals the process behind developing the project and the corresponding product. As far as possible, the report is chronological build. The process report has five phases as stated in the table of content. Each phase will start with an introduction. To track when the project changes viewpoint or new criteria's are identified a box with an '!' is shown.

Product report: The product report presents the product's features, use scenarios, aesthetics experience, manufacturing aspects and the business potential.

Appendix: The appendix consists of supplementary worksheets displaying the team's project process. References to the worksheets will be shown as 'Worksheet #'.

Table of content

Titlepage	2	Ideation	36
Table of content	3	Ideation	38
Project Staging	4	Identity Development	40
		Workshop with 4th Grade	42
		Workshop with Parents	44
Pre-phase	6	Defining the Concept	46
Project Background	8	Concept Development	48
Project Direction	10	Proof of Concept	50
Framing	12	Detailing	52
Target Audience	14	Development Strategy	54
Detouring	16	Project Cost	55
User Study	18	Functions & Means	56
Personas	20	Form Variation	58
Design Brief	22	Plant Support System	60
		Watering System	62
		Light System	64
		Materials and Manufacturing	66
		Evaluation	67
Research	24	Project Closing	68
Coping Principles	26	Concluding Remark	68
Motivators	28	Process Reflection	69
Playful Learning	29	List of References	70
Hydroponic Cultivation	30	List of Illustrations	71
Hydroponic System	32		
System Architecture	33		
Value Creation	34		
Criteria formation	35		



HENRIETTE BIRCH HANSEN

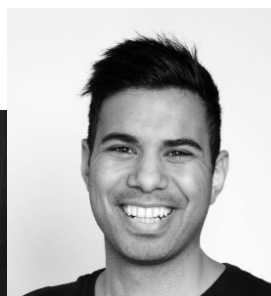

YUSSEF ABDUL-KARIM

Project Staging

Team Identity

Sprout is the name of the design team behind this project. The name is inspired by the teams shared passion of connecting user needs and values with opportunities and thereby creating ideas which can sprout into new value adding products.

Creating a team identity helps to get a shared viewpoint on the project and strengthens the team's identity. Having a team identity helps to define and align the team's project objectives and overall purpose.

sprout

Team Learning Objectives

The curriculum for the Master Thesis has set the scene for the learning objectives. Despite this, the team still has to define the project approach and objectives, to get closer to having the skill-set to support the professional design profile the team members each seeks.

To align within the team a spider web with shared project objectives and understanding here off are made. The spider web below shows what the team aspires to focus on throughout the project.

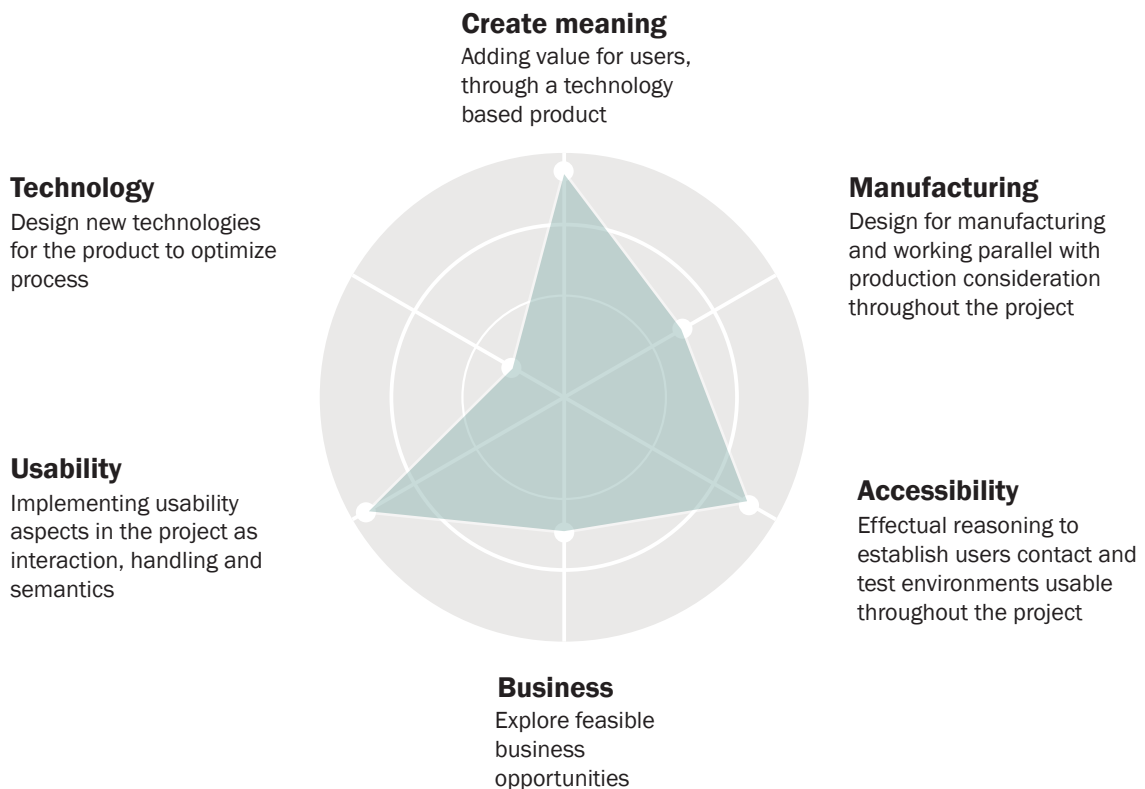

Approach

The project started as an opportunity to implement an existing technology in a product. Depending on the project approach, it could end in a technology push project. A technology push project is not desirable and what the team wanted to explore. Therefore Roberto Verganti's framework of creating meaning in a product is applied (Verganti 2003). Focusing on satisfying the operative needs of the customer as well as adding a layer to the solution that stimulates the user affective and sociocultural needs (Verganti 2003).

To achieve the above principles from Design thinking are applied focusing on identifying user needs and values furthermore to empathize on their struggles and desires (Laursen 2014). The project are user centered focusing on ideating and testing multiple principles until finding the prober one.

Throughout the process an various of methods and approach are applied.. In each section an overview, description and reflection on the methods and approaches are described.

Project Milestones

The project is carried out over a period of 16 weeks, where the team with guidance from supervisors has been self-organized in terms of detail planning, methodology approach and conducting project-promoting activities. To ensure progress in the project, there have from the studies side been arranged two mandatory status seminars (Status 1-2), where the project is presented to supervisors and fellow students. To ensure even further improvement of the

project's development, there has been arranged three additional internal status seminars (Status A, B, C) by the students, which makes it possible to test the project communication continuously and receiving feedback on both the project findings as well as presentation strategies. Below an overview of the main milestones is marked in the timeline starting from project start until hand-in of the reports.

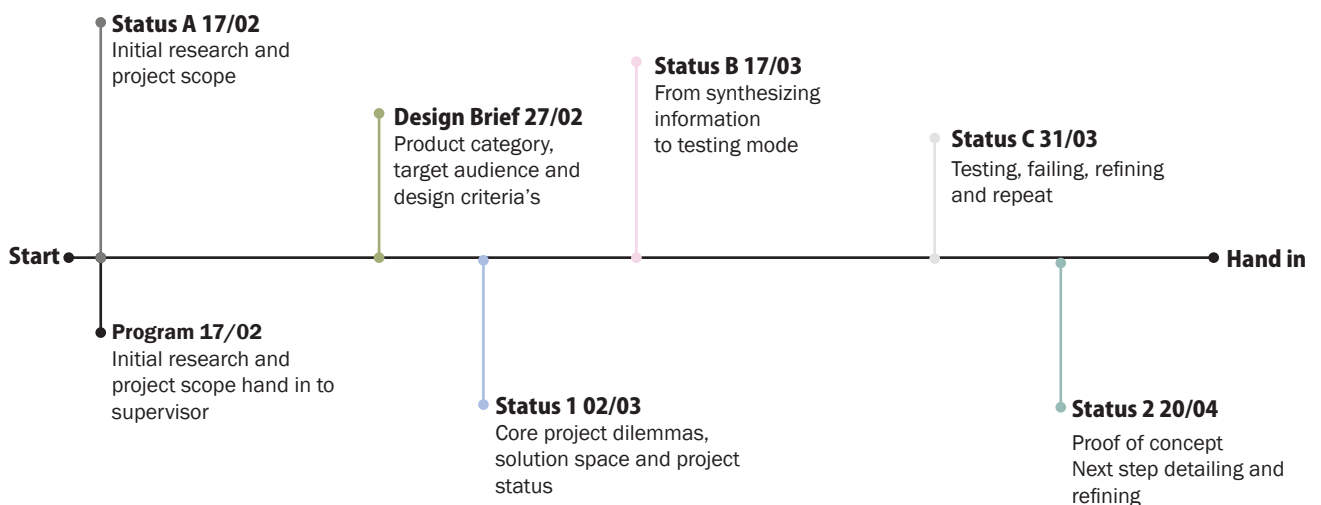

Pre-phase

Introduce, Describe, Choose

The following sections present the background for this project and the theme for the rest of this report. Furthermore, this section gives an overview of the process of defining the project direction. The outcome of the pre-phase is the initial project statement.



ill.0:Basil



Project Background

Project Introduction

In the process of choosing a topic for this project, the team became interested in studying technology-based food cultivation. The team gained insight about this topic from one of the team members, who prior to this project had been an intern in the company Plantui. The team was presented with the opportunity to collaborate with Plantui Oy.

Company Recap

Plantui produces and sells hydroponic indoor gardens to consumers around Europe and Asia. The indoor garden can grow leafy greens and herbs all year around due to the hydroponic technology. Plantui launched their first Plantui 6 Smart Garden in 2014 in Denmark and were one of the first on market in this product category. In 2017, Plantui's portfolio consists of the Plantui 6 Smart Garden, Plantui 3 Smart Garden (illustration 1) a wide range of seed plant capsules and accessories. Plantui faces six competitors who more or less sells similar offerings to the same markets as they do, view Worksheet 2 for more information.



III.1: Plantui 3 and Plantui 6 Smart Garden

Plantui Collaboration

Plantui is interested in seeing what could come out of a collaboration with the team and therefore they did not pre-define a project. Initially, the team approached the task as a design consultancy firm and tried to analyze Plantui to see how and with what they could enter a new market, see Worksheet 3 and 4 for company analysis. The task would hereby consist of expanding Plantui's product portfolio and thereby either enter a new market or expand the current market share.

The team changes the approach and choose to see Plantui as a potential stakeholder. Meaning the team are focusing on exploring the project thematic instead of focusing on doing what is best for Plantui's future portfolio. This decision is made to let the team explore the topic, without being locked by the company's point of view.

The Hydroponic Technology

This section gives an overview of the hydroponic technology, where it is applied and how consumers perceive it. In illustration 2 an overview of a hydroponic setup is showed.

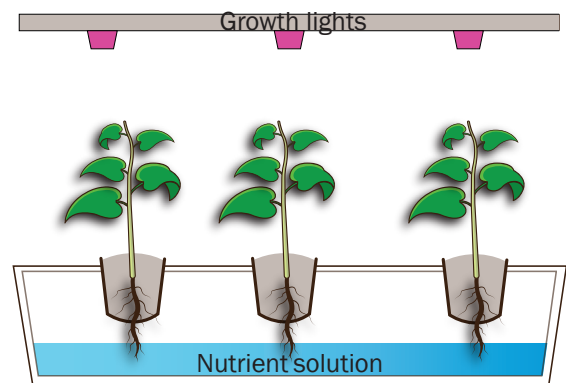

III.2: Hydroponic cultivation system

Hydroponics is a method for cultivating plants by placing the roots in a liquid nutrient solution instead of soil. Meaning that the plants grow without any soil at all. The ratio between nutrients, water, and the plants needed intake are highly controlled to give the optimal conditions for plant growth. In most hydroponic systems, artificial LED lamps are integrated to give the optimal light spectrum for the photosynthesis (Cuffari 2016).

The main benefits of using a hydroponic system for food cultivation is less water consumption, faster plant growth, higher yield compared to space occupation and plants with a higher vitamin yield (Cuffari 2016).

Area of Application

Hydroponic cultivation is mainly applied in industrialized agriculture for large-scale farming (Gorwponics 2016). Never the less, hydroponics systems are rapidly emerging the consumer market and every month new concepts are presented on platforms like Kickstarter.

Research shows that industrialized agriculture worldwide is adapting to using hydroponic technology for growing crops, fruits and vegetables (Gorwponics 2016).

INDUSTRIALIZED
AGRICULTURE

Consumer's products focus on adding a supplement of greens to the household. Garden Media states that the hydroponic indoor garden stores made \$1 billion in 2015, and the market has increased 8,2% the last five years (Garden Media 2016).

CONSUMER
GARDEN

Technology Perception

Dickson Despommir, specialist in hydroponic farming, argues that hydroponic technology has come to stay because of the great potential of moving food production back to cities. Furthermore, he argues that hydroponic technology will enable a high enough yield to produce enough food for the increasing world population. Among others, he describes hydroponics as clean technology because it has less impact on the environment compared to conventional agriculture (Despommire 2011).

The team made an investigation of consumer's knowledge about hydroponic systems. Team Sprout interviewed randomly picked respondents and asked them if they had heard about hydroponic systems. The answer was "no not really" from all respondents (Worksheet 5). To gain insight into consumer's perception the team showed a group of respondents the Plantui 6 Smart Garden. The recurrent responses are displayed to the right.

"Weird light color, it doesn't look natural."

"Where is the water?"

"Where do the vitamins come from?"

"Is it healthy?"

"Where is the soil - it can't grow without soil?"

"How does it work?"

"It looks like a spaceship not a product for growing healthy food"

The Hydroponic Paradox

The initial research unfolded a paradox, on one hand, industrialized agriculture is moving towards a hydroponic cultivation setup, meaning that food purchased from supermarkets are or will be hydroponically produced. On the other hand, consumers associate hydroponic food production as an artificial/unnatural process and have a skeptic view of the health and quality of the plants produced in the systems.

Paradoxically most of these hydroponic skeptics have eaten hydroponic produced food, or they will eat it in a near future.

The paradox makes some interesting points, which creates the foundation for the first project statement.

!

Initial Project Statement

This report will investigate the process of making hydroponic growing systems less alienated for consumers.

!

Initial Project Criteria

*-Transparent hydroponic cultivation system
-Give insights into what the technology offers*

Project Direction

Trend Spotting

To understand the facets of hydroponic based food cultivation a perspertation to the most relevant megatrends is made. The objective is to identify and define trends, which support the yet to come product, but furthermore, gives a frame of reference to understand the nuances in a potential solution space. Below three mega trends with sub-trends are shortly described.

Approach

The approach applied to identify trends and apply them in the project is as following:

1. Identify multiple trends (Worksheet 6)
2. Define and categorize
3. Perspectives on the project
4. Generate project directions
5. Choose one direction

Perspertation

Trend experts describe the three mega trends mentioned as a paradigm shift in social values due to the financial crisis. Consumers seek to a greater extent transparency, authenticity and elements, which create bonds between individuals. Urban gardening is a symptom on this and is still becoming a more central part in people's life (Mikkelsen 2016).

Working with the trends helped to define potential project directions as showed on the next page. Throughout the project, these trends will be kept in mind as a reference frame.

TREND #1 URBAN FARMING

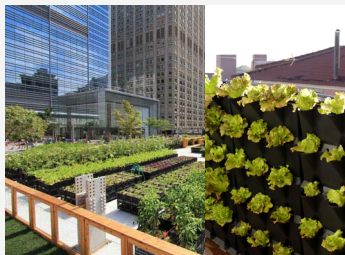

III.3: Urban Farming

DESCRIPTION

Urban farming and gardening take place in the cities around the world. Different scales exists depending on location and the farmer's skills and expectations. Urban farms and gardens often work as communities where experience and knowledge are shared amongst the farmers.

LIFESTYLE TRENDS

Balcony gardens
Føtex 'Plantepotter'
Plants in interior Design
Chili growers

TREND #2 BACK TO NATURE



III.4: Back to Nature

DESCRIPTION

A tendency of urbanites is trying to connect with nature. Some people go all the way and live off-grid, where others buy a cabin or allotment in the countryside. For the less determined urbanite's trips to a farm on 'Økodagene' or watching an episode of 'Bonderøven is enough'.

LIFESTYLE TRENDS

Bringing nature indoors
Styling based on natural materials
Outdoor activities
Digital Detox
'Økodagene'

TREND #3 SUSTAINABLE FOOD



III.5: Sustainable Food

DESCRIPTION

Throughout the last years, consumers have made a stand when it comes to food. Consumers buy more organic or ecologic produced foods. Terms like 'By Local' are all around and more people are concerned about food waste and packaging waste.

LIFESTYLE TRENDS

'Stop Food Waste' campaigns
Flexitarian, Vegans, Vegetarians
"After hours" restaurant food
Packaging free supermarkets
Local farms markets
'Årstiderne' food boxes

Potential Project Directions

The objective of this investigations is to identify and specify potential target audiences to work with. In the process of defining the project scope, trends and potential project directions are examined simultaneously. The table below gives an overview of potential project direction identified by team Sprout. Furthermore, a description of the identified opportunities

and the team's initial insights. In the process of choosing one direction, the team mapped pros and cons and chose to work with number 3. Teach children about plant cultivation. This initiated a project frame and the first product criteria's. Next step is to investigate the target audience and get an idea of the solution space.

TARGET AUDIENCE	OPPORTUNITY	INSIGHTS
1.SUPERMARKETS	Supermarket farming: Enabling the supermarkets to grow greens in the store, thereby give the customers insight in the growing process, and be a first mover within the field.	-In-store farming -Focusing on the trend of sustainable food, -If the customers demands it supermarket will follow
2.RESTAURANTS	Creating a product aiming towards giving the chefs a possibility of growing their own vegetables directly in the restaurant - unique selling point for the restaurant.	Growing interest in cultivating vegetables among restaurants. Increase in demand from chefs – needs a suitable hydroponic system for the restaurant
3.TEACH KIDS (SCHOOL/HOME)	Creating a product that aspired to give children a first-hand experience and knowledge about the cultivation process.	- Plantui has investigated this, and the kids showed great interest. (Worksheet 7) - Føtex made successful cultivation kit - Parents want to show their kids where food comes from
4.OFFICES	Optimize how companies can integrate plants in their surroundings and work with the indoor air quality and work settings.	- Focus on plant in buildings is at its highest. - People think more clearly and there are other benefits related to having plants around you. - “Third place” offices
5.CONSUMER	Home growing device that allows the user to have a first handed experience with growing greens, and potentially become self-sufficient.	- Føtex ‘Plantepotter’ success - Growing interest in buying local and organic food. - Growing interest in bringing nature back into the home and urban gardening
6.THIRD WORLD “SAVE THE WORLD”	Solar driven device that would help people in third world countries cultivate greens and thereby be self-sufficient.	- World hunger. - We are becoming more and more people, by 2050, we will be 9 bill. people, (and lack around 60% of food compared to today?) (Despommire 2011)



Project Frame 1

Give families a first-hand experience in hydroponically growing greens and expand their knowledge about the food they eat.



Initial Project Criterias

- Give families knowledge about hydroponics
- Give first-hand experience with food cultivation
- Usable for both children and adults
- Be applicable in or near the family home

Framing

Empathizing, Sensemaking, Defining

The objective of the framing phase is to define and gain insights about the target audience. Furthermore, this phase will investigate what the users need from a solution, and propose how to achieve it in a design brief. The output of the framing phase is a clear understanding of the target audience, a frame from which the project is viewed pushing forward and the first design criteria's.

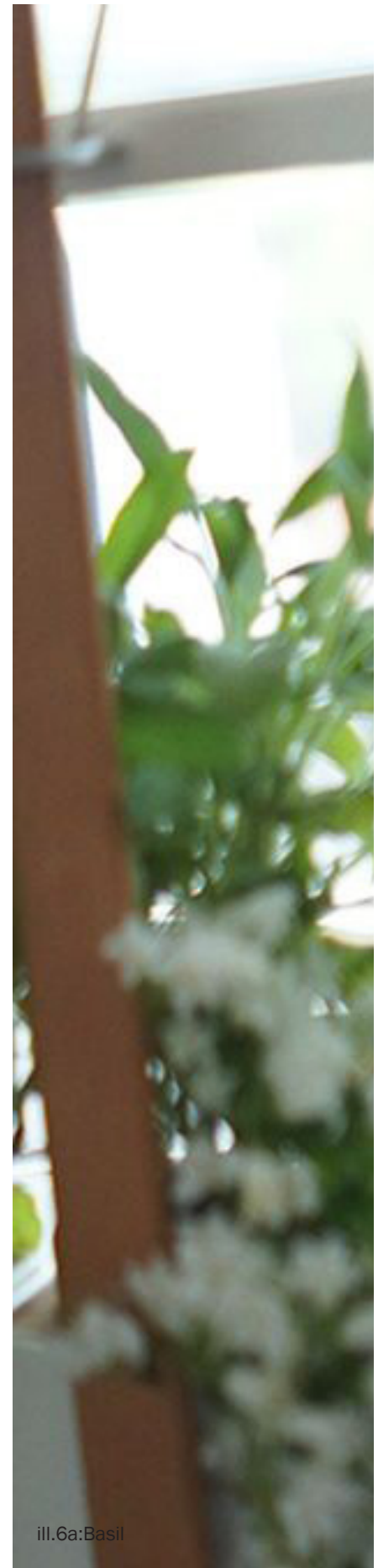

ill.6a:Basil



Target Audience

Background & Objective

The decision of working with Danish families with children as a target audience helps to set boundaries for the project. The target audience needs to be specified further. To narrow the target audience down and get a general understanding of the users, research about the families are conducted.

The research focuses on uncovering family types and constellations, families daily life. Furthermore, the research uncovers the families core everyday dilemmas and values.

The information in this section is based on a large study called 'Den Digtale Familie' conducted by Envision a Danish advertising and consumer insight agency in 2016 (Envision 2016). The Envision study data comes from Envisions own investigations in form of qualitative interviews with 27 families. Additionally, the research is supplemented with statistics done by 'Danmarks Statistik' (Envision 2016).

The Family in 2017

Denmark has 789000 families with children distributed in 37 different family constellations. Even though there is a diversity in the family composition, 55% (434000) of the families are based on the industrial family setup, consisting of a mother, a father and one or more children.

The number of single parents is still increasing. Today there are 149000 single mothers. Likewise, today's number of single dads in Denmark are 33.000 (Envision 2016).

Even though the family constellation has a broad span, there are some general characteristics patterns in most of the Danish families. The Envision study unfolds the core family values and how they are perceived.

Family Values

In the process of identifying family values, the Envision study helped to identify and understand valuable aspects in the family life. The value identification is only based on the parent's

viewpoint and therefore lags the children's perspective on the topic. Below is a description of the top six elements, the family values.

FAMILY TIME

Quality time is when the family are together and doing activities.

CREATE MEMORIES

Families want to create memories through vacations, trips, games, outdoor activities or just playing a board game.

LEARN ABOUT EACH OTHER

Good time spent with the child is when the parent learn new things about the child

TEACH CHILDREN SKILLS

Parents want to teach the children skills as cooking, using tools, painting, gardening etc. to pass on needed life skills

FOOD COOKING & DINNER

Children and parents enjoy gathering around dinner and cooking. Parents believe this is the time of the day, they are most connected with the children.

INDIVIDUAL TIME

To have alone time either, with their partner or to do personal hobbies and activities.

Time the Eternal Dilemma

The study highlights the families problems with having “enough” spare time to family activities. Furthermore, the study proposes that families are in need of tools or offerings, which can release time from existing activities. Even though the families feel like they need more time, statistics shows that an average adult Dane has eight hours of spare time every single day. This is the equal amount of spare time Danes had 45 years ago (Belingske 2015).

The Idea of “Quality-time”

To accommodate not having enough time most families implement quality time.

Parents use the phrase ‘quality time’ to describe the time, parents take out from their schedule to focus 100% on the family. The study indicates that quality time has become the parent’s strategy to compensate for time not spend with the children. Never the less all 27 of the case families from the study describe quality time as being present in the family (Envision 2016).

Childrens View on Family Time

The Envision study only looks at quality time from the parent’s point of view. This section will highlight how children perceive quality time. Pia Christensen, a senior researcher at the Danish State Department of Public Health, has written an article based on two surveys, diving into how children define “family/quality time”. The surveys are based on children in Northern England (70 children) and Copenhagen (respondents unknown), in the age of 10-11

The article clarifies that children’s understanding of quality time is broader and more nuanced than the one often highlighted by the parents.

One of the main takeaways from the article is that the time, the children appreciate the most, is the daily life in the family, time consisting of daily routines without special events. Being in the family and taking part in the normal daily routines together, that is “family time”.

Both the Danish and English children think dinner is a central part of the quality time. In many of the families, dinner is the only time the family are united and spending together. The Danish survey showed a strong relation between the Danish term ‘hygge’ and quality time. The children experiences ‘hygge’ as a time where everyone was together even though parallel activities are allowed. Rebecca one of the respondent from the research states:

*“Sometimes I do stuff **with** my family, it’s not often we do stuff **as** a family.”*

- Rebecca.8 years old

The Time Dilemma

Reflection upon the insights from the Envision study it shows that the family desperate seeks products and offerings that can eliminate time-consuming task and generate ‘free-time’.

A concluding remark is that the families, children as well as parents, enjoys spending time together. The parents have higher expectation to quality timer where children often experience quality time as just being together with the rest of the family.

!

Project Frame 2

Give families valuable time together, where they learn new things about each other and are present in the moment.

!

Initial Project Criterias

- Give families valuable time together
- Let family members learn about each other
- The solution should not fell like a time taker
- Easy to implement in the busy daily life

Detouring

Fail Fast, Succeed Faster

Being distracted by the many problems and dilemmas presented in the Envision study the team became too focused on the time aspects. The technology based food cultivation suddenly seemed irrelevant in relation to the target audience. Therefore the team took a detour into an entirely different project direction.

The focus shifted from technology based cultivation to improve family quality time. The project is at this point focusing on innovating on an existing situation the family encounters daily, to see if a new product could help to generate a more valuable family time in the busy life.

A brainstorm is conducted and summed up to four potential directions, where family time can be enhanced; cleaning, food, bathroom and learning as shown in illustration 6-8. The four directions are investigated through a rapid market research, to identify who else is trying to offer products in the four categories.

Based on the four thematics and the market research, an ideation is made to open up and investigate the solution space, see illustration 6-9. To see more of the process view Worksheet 11.

CLEANING & PLAY

Vacuuming, dish washing, dusting etc.



Ideation combining play and cleaning

a. Build a helper



b. Playful cleaning



c. Point table



- a. build a cleaning robot yourself
- b. cleaning cards to make it like a game
- c. point board to see who cleans the best

III.6: Market research and ideation - Cleaning and Play

BATHROOM & PLAY

Toothbrush, bath, toilet visit, cut nails etc.



Ideation combining play and bathroom

d. Playful hand-washing



e1. Teach to brush

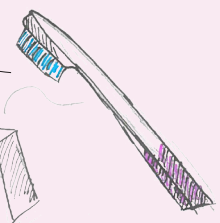

e2. Playfull interaction



- d. guides you to wash your hands better
- e1. Interactive toothbrush guides the child
- e2. Small box who evaluates the tooth brushing

III.7: Market research and ideation - Bathroom and Play

FOOD & PLAY

Cooking, cultivation food, eating etc.



Ideation combining play and cooking



- f. shows interactive food grower
- g. personal tamagotchi plant grower
- h. shows a pot which talks about the food

III.8: Market research and ideation - Cooking and Play

Output

After making the market research and the ideation on the four directions in illustration 6-9, the team evaluated the concepts. In the process of evaluating the concepts, a reflection on the approach and how the project ended in this 'new' direction were made.

It became clear that the Envision study research has lead the team away from the main objective of this report, investigating technology based food cultivation. The team has to decide on either to proceed down this path or go back to the original project objectives. The team decided to get back on track and focus on technology-based food cultivation with Danish families as a target audience.

LEARNING & PLAY

Educational play, outdoor, programming etc.



Ideation combining play and learning

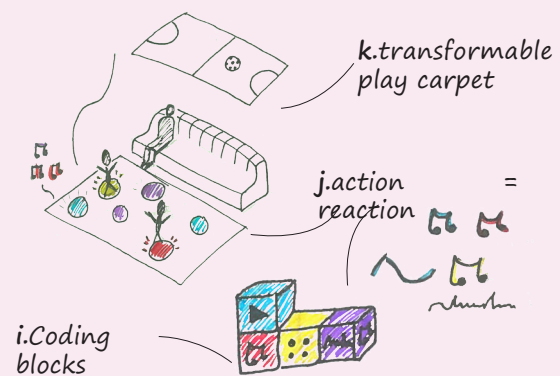

- i. shows coding building blocks
- j. shows coding building blocks with sound
- k. shows interactive play carpet like Twister

III.9: Market research and ideation - Learning and Play

Valuable Insights

The detour help to get a new understanding of the project frame. One of the elements worth considering is to add elements of learning and play into a cultivation system. This can maybe help to get a new perspective on how technology based food cultivation can be. Next step is to investigate if the frame makes sense in relation to the target audience needs and expectation. To do this an investigation of the users are conducted.



Project Frame 3

Give families a valuable and playful time together while learning about the cultivation process in a hydroponic system.

User Study

Background & Objective

Focusing fully on technology-based food cultivation again makes it crucial to push the project forward and get a specific and clear direction on the project. To do this a series of user studies are conducted. Each user study has an individual objective but the common denominator for all of the studies is to identify which direction the project should move towards. Innodoors framework for conducting a structured interview are applied (Cankaya et al. 2010).

Approach

1 Quantitative user study conducted as an online questionnaire targeting parents, shared on Facebook.

The questionnaire uncovers

1. Demographics
2. Food and grocery shopping habits
3. Food cultivation habits and experience
4. Exchange of contact information

2 Email interviews with 10 respondents who answered the questionnaire.

The email interviews investigates

1. Family values and activities
2. Cultivation experience and expectations

3 Qualitative interviews with four randomly picked families in Leos Legeland

The interviews investigates

1. Family values and activities
2. Cultivation experience and expectations

Working Hypothesis

There are two main working hypothesis the user studies aspires to undercover.

1.If parents are interested in teaching the children about food and food origin, they will like to cultivate food together in the family home.

2.There are some people who prioritize cultivation food in a larger scale they probably will not buy an indoor garden.

1 Quantitative Survey

In the following section the main insights, which has pushed the project forward, is displayed. To see the full questionnaire view Worksheet 12.

The questionnaire is carried out as an online survey shared on social media, targeting parents who have children living at home. The questionnaires main objective is to understand if the Danish families are interested in food cultivation within Danish families. The survey was actively filled out over a period of five days. In total 134 parents answered the survey.

Key Findings

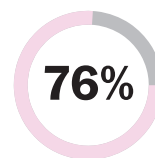

Have tried to cultivate food

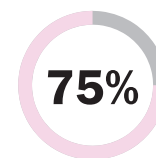

Want to grow more greens by themselves

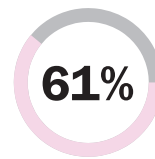

Cultivate food because they want to teach the children about it

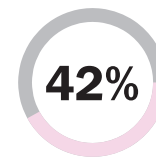

Lives in apartments, half of these do not have any outdoor space available

III.10: Key numbers from survey

The respondents are asked, why they cultivate food, the answers and percentage can be viewed in the pie chart in illustration 11.

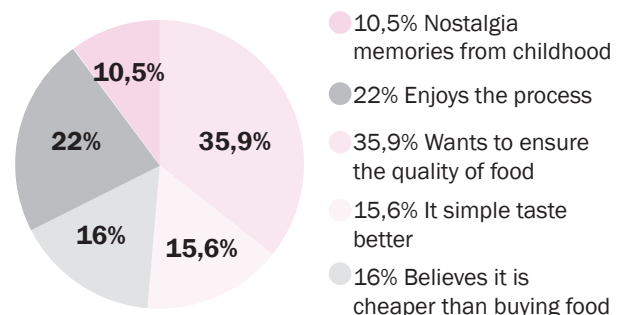

III.11: Pie chart from survey

2 Email Interviews

The interview template is sent to 29 parents. They all are respondents from the survey who agreed to receive follow-up questions per mail. 10 of the 29 responded. Full interview template and answers can be viewed in Worksheet 13.

Errors

The answers in the email interviews have to be viewed critically. Due to the format of the interviews, it is not possible to read tone, body language or get an elaboration on the answers. The main findings from the email interviews are stated below. The answers are viewed critically and used as an indicator of what needs to be elaborated in the qualitative interviews later on.

Key Findings

FAMILY VALUES AND PERCEPTION OF QUALITY TIME

- All of the respondents has the same answer: that family value is when everyone is together
- The respondents with children between 0-4 had similar statements like: "It does not matter what we do as long as we are together."
- Respondents with children from 5-14 states: "Valuable family time is when we do something special together." It could be PlayStation, bicycle, vacation, trips. They identified products that helps to facilitate the family time.

PRODUCTS AND ACTIVITIES BRINGS FAMILY TOGETHER

- Board games
- Trängia
- Sandbox
- Toys
- Play station
- Television
- Swimming
- Gardening
- Trips (museums etc.)
- Bicycling
- Being out in nature
- Vacations

Output

The products and activities the families believes bring them together are interesting to investigate further to understand the mechanism in these things which bringing the family together.

3 Qualitative Interviews

The qualitative interviews in Leos Legeland focus are to elaborate the questions from the email interviews and to get a more nuanced dialog about family values and cultivation desires. Full interview template and answers can be viewed in Worksheet 14.

Errors

Leos Legeland is the only place who did not mind the interviews. The context for the interviews was a bit hectic, which affected the interviews. Never the less new viewpoints and greater insight are achieved.

Key Findings

EXPECTATION AND PERCEPTION FOOD CULTIVATION

- All of the respondents associate food cultivation as an outdoor activity and states they would prefer it being outdoors.
- 50% of the respondents enjoys the process of cultivating food. But think it is time consuming.
- The other half like the produce of greens to the household more than the process itself.

VALUE IN FOOD CULTIVATION

- Show the children where food comes from and how it is produced.
- Gives a feeling of self-accomplishment.
- Nice to tell others about the achievements.
- Quality stamp when it is cultivated at home.
- The children enjoys it and love to see things grow

Output

There is a great interest in food cultivation in general. It is interesting to see that cultivation stimulates families, mentally, physically but also gives a feeling of self-achievement. The studies are used as a baseline for the rest of the project.



Initial Project Criterias

- A product should engage the whole family
- Accommodate a variation in cultivation experience
- A family activity more than a food producer

Personas

Background & Objective

The personas help to align the teams understanding of targeted audience needs, motivations, behaviors, and struggles in relation to food cultivation. The personas are used as a tool to portraying the many different

family constellations and summing it up to two stereotypical families (Schneider et al. 2012). The information in the personas is based on the Envision study and the team’s user studies.

“The most valuable thing for us is to have energy and time to be together. It doesn’t matter what we do, as long as it’s together we do it.”



III.12: Family Jensen

FAMILY JENSEN

MOTHER NANNA, 34
 SON STORM, 10
 SON VIKTOR, 8

LIVES IN APARTMENT
 OUTDOOR SPACE NON
 LOCATION DENMARK

CULTIVATION TYPE BEGINNER

Only tried to cultivate a few tomatoes in living room window. It did not go well, nobody knows why.

FAMILY BEHAVIOR

The family has few rules and do not really plan. They take one day at a time and rarely stress. The family have many individual interests and activities, which they use a lot of time on. They try to meet around activities they all find fun, such as playing PlayStation or outdoor activities like biking, but often forget to spend time together.

FAMILY GOALS

To be connected as a family
 Creating shared memories
 Learn thing about each other
 Have independent children

PRODUCT QUESTIONS

How does it work?
 Is it healthy?
 How much does it cost?

FAMILY MOTIVATORS

Activity based
 Everyone can be a part of it
 Benefits the children’s and parents learning and health



“ Spending focused time together is important to us. It is important to prioritize time for each other in a busy daily life.

III.13: Family Hvid

FAMILY HVIID

MOTHER CAMILLA, 38
 FATHER JOHAN, 38
 SON OLIVER, 6
 SON LUCAS, 4
 DAUGHTER ASTRID, 1

LIVES IN FAMILY HOME
 OUTDOOR SPACE LARGE GARDEN
 LOCATION DENMARK

CULTIVATION TYPE EXPERIENCED

Grows small amount of greens in outdoor plant boxes. Been doing it for three years and are ready to add new greens they never tried before.

FAMILY BEHAVIOR

The family want to spend much time together, but work and daily activities can often come in the way. They plan their daily life, to ensure efficient usage of time, and try to do most things together regardless if it is playing or house chores.

FAMILY MOTIVATORS

Child friendly
 Easy to maintain
 Fun
 Everyone can be a part of it
 Benefits the children's health
 Teach the children new things

FAMILY GOALS

To be connected as a family
 Grow closer together
 Learn new thing about each other
 Teach our children about a healthy life

PRODUCT QUESTIONS

How does it work?
 Can our kids do it?
 How much time will it take?
 Is it healthy?
 How much does it cost?
 Can it fit into our home?

Output

Personalizing the target audience helped to align the teams understand the users. The persona's sums up the various insights about the users to two general families. The most interesting part of the personas is the nuances in how they think, get motivated and how they act towards a new product.

The personas will be used throughout the design process as a tool to evaluate concepts later on. Furthermore, the making the persona's helped to reflect on what the target audience really value.

The information about the users and the initial research a summed up into the first design brief.

Design Brief

Introduction

The objective of the design brief is to align the team members and get a clear understand of the project scope. The design brief objective is to move the project forward and aligning the team's perception of the project direction. The design brief is based on the framework from the book 'Creating the perfect design brief' (Phillips 2004)

What - The Product



The product is an indoor cultivation system for producing eatable plants.



The system uses hydroponic technology to give the plants optimal growth conditions all year around.



The product helps the user to gain insights and learn about the food cultivation, through a transparent cultivation process.

Who - The Target Audience



Danish Families with one or more children
The children age are 3-11 years old.



They mainly lived in apartments with little too none outdoor space.



Common denominator: Wanting to teach children about food.
Do not know anything about hydroponic food cultivation and are skeptic about it.

Why make a hydroponic system?

There is a growing interest from consumers in food quality and food cultivation. Research done prior to this design briefs indicates that parents especially uses energy on providing the best food for their children (Worksheet 15). Furthermore, the parents empathize on the importance of showing and teaching the children how food originates. Therefore, it is interesting to investigate how a product can provide knowledge to children and parents about technology based food cultivation and at the same time get high-quality food.

In order to accommodate the contextual and time limits the families face, the food cultivation will be hydroponically based the benefits will be elaborated on page 31.

Consumers are skeptic about hydroponic technology and its effect on the quality of the food. The team needs to overcome this obstacle in order to make a successful project. From these reflections and the research about the target audience, the project vision and mission are generated.

Vision



“**Make tech growing more nature-like.**”



Mission

“**Give families enjoyable time together through the experience of growing greens.**”

III.14: Visualization of vision

Project Success Criterias

1. The target audience want to use the cultivation system
2. The cultivation system can be operated by adults as well as children
3. All family members can interact with the cultivation system at the same time
4. Developed a cultivation system where the plants can grow
5. Users have learned new things about cultivation and/ or plants

Intial Design Criterias Sum Up

- The product should invite all family members to interact with the product at the same time
- The product should give the family a feeling of being connected while using it
- The product should be suitable in use for children as well as adults
- The product should feel like a family product more than a food producer
- The product should give insight and knowledge about the cultivation process
- The solution should involve and stimulate the senses throughout the growth process
- The product should be applicable in the family home
- The product should be easy to implement and use in the busy daily life

Category Review

The design criterias helps to identify the product category, the yet to be designed cultivation system, should fit into. Illustration 15 shows the teams reflection of where the product should be located.

The conclusion is the product should feel like a playful family gardening product. Still, it should be inspired by the existing hydroponics systems ease of use and technology.



Ill.15: Product category reflections

Project Road-map

The team are aligned in relation to the project direction. New research questions emerges from the design brief. The next step is to define the research questions and start a rapid research phase to uncover the most critical questions.

Research Questions

How to meet the criterias? Are there exiting coping strategies or mechanism that can be copied?

How to make a product which is interesting for a vwde age span?

What is important when it comes to hydroponic cultivation and how should this be applied in the new product?

Research

Investigating, Understanding, Synthesizing

The Design Brief from page 22-21 defined new research questions. This phase will present and describe the approach and research findings. The research phase is divided into two themes.

- 1. Learn more about families*
- 2. Learn more about cultivation*

The output from this phase is a synthesis of how the findings will be applied and understood moving forward in the project.

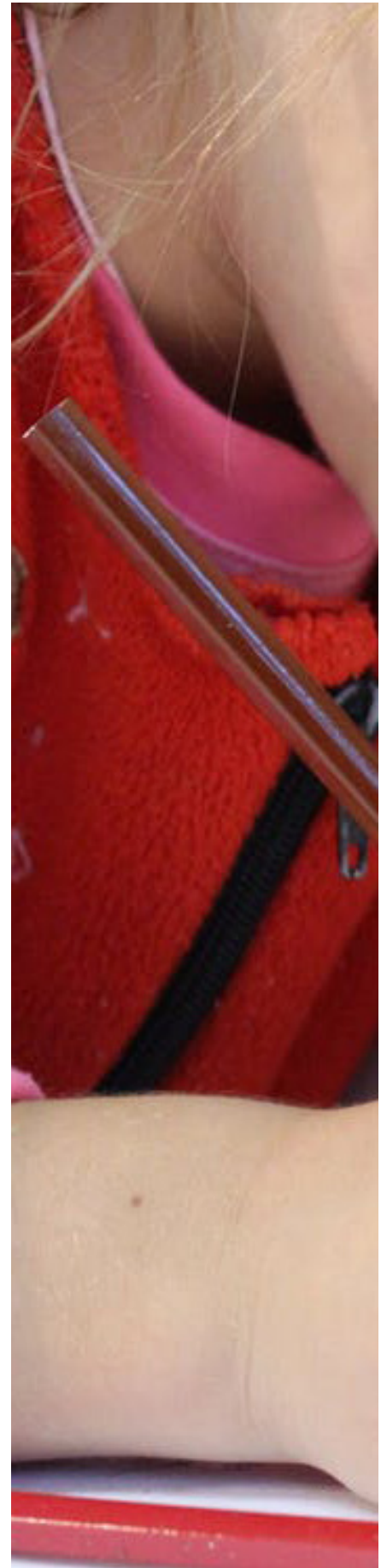



ill.16a:Kids

Coping Principles

Identification of existing principals

The first part of the research phase focus on identifying principles and mechanism which can fulfill the criterias to the right
 Insights from the user studies and a brainstorm mapped out products that, in one way or another, fulfill one or more of the criterias. The four principles are mapped and analyzed to understand the core principles.



Project Criterias

1. The product should invite all family members to interact with the product at the same time
2. The product should give the family a feeling of being connected while using it
3. The product should be suitable in use for children as well as adults

Principle 1 Centerpiece

The principle of a centerpiece interaction is that the players gather around the object, as for an example a board game. The board game manifests a set of rule for the player to follow. In many games, it is up to the participants to decide if and how much, they follow the rules. The participants can also decide to do other stuff like talk and laugh while playing. Board games can join people in different age groups with different interested and level of knowledge.

Core interaction principle

1. Interaction between individual and board
2. Interaction between multiple individuals and board
3. Interaction between individual regardless to the board

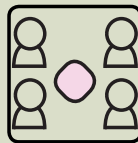

III.16: Family interaction with board game

Products using the principle:

- Board games
- Gaming consoles
- Trångia

Principle 2 Process

Interacting with or observing a process can be done by either one or several users. There is a common goal, which is getting to a specific point, either cooking food or building a specific object. Within the process, there are several touch-points to interact around and with, but more importantly, the users are together about making the result, in this case, a meal.

Core interaction principle

1. Interaction between individual and process
2. One process multiple parallel activities
3. Same goal different task and approach

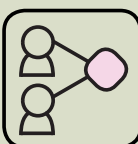

III.17: Cooking process

Products using the principle:

- Cooking food
- Taking care of pets
- Building LEGO
- DIY projects

Principle 3 Creative space

A physical predefined frame that facilitates play. The sandbox itself works as an arena where sand is the medium played with. Other tools like buckets etc. can be a part of the play but the sand is in focus. The play is mainly limited to be within the sandbox, but the creativity released within is undefined. The interaction created can either be directly or indirectly or parallel play.

Core interaction principle

1. Parallel play
2. Focus on playing together
3. Focus on play with the sandbox

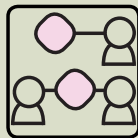

III.18: Children playing in sandbox

Products using the principle:

- Board games
- Gaming consols
- Tranjia

Principle 4 Community

Each person has their own product/game that they take care of and spends time, effort and money on to maintain, pimp and improve. The activity itself is primarily done individually, but the sense of community comes in when people interact together, about the product/game. It can also come in a more indirect way when the player's talks and share experience, knowledge, and inputs with each other.

Core interaction principle

1. Play or interact alone
2. Share insights with others in community

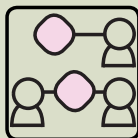

III.19: Pokemon Go

Products using the principle:

- Pokemon Go
- Biking teams
- Tamagotchi

Output

The principles identified can all for fill the criterias depending on how it is applied in the cultivation system. The principles are ranked as following from 1-4. Where 1 is the principle the team believes will fulfill the criterias bes:

1. Centerpiece
2. Process
3. Creative space
4. Community

It is possible that the team are wrong. Therefore the four principles presented here will form the basis of ideation and later testing of concepts. This approach will give an indication of which interaction principle the cultivation system has to mimic to fulfill the criterias.

Next step is to identify elements which will stimulate the family desire to cultivate greens in the new cultivation system.

Motivators

How to Maintain the Fascination?

The objective is to understand which elements the new cultivation system can use to keep the users interested in the product.

The user studies revealed that the target audience likes different aspects of the cultivation (Worksheet 13). The cultivation process can roughly be divided into seven phases as showed to the right.

This section will look at two strategies to keep the fascination or motivation. Some of these elements can be added to the cultivation system to amplify the existing peaks.

Cultivation Peaks

1. Before cultivation choosing plants
2. So the seeds
3. Germination first leaves are visible
4. Follow the plant while it grows
5. Take care of the plants
6. Harvest
7. Eat or produce food from the crops

Approach 1 Gamification

Gamification is built on the idea of adding game mechanisms into non-game activities or processes; to enforce the engaging, influencing and motivation, of the user. Hereby creating an addictive experience that motivates users to take specific actions, and to return more frequently. Gamification can be divided into two categories, game mechanics, which are the basic game actions, and game dynamics, which are the motivating and compelling desires (Huotari et al. 2012)

GAME MECHANICS

Points
Levels
Challenges
Virtual goods and spaces
Leaderboards
Gifts and charity

GAME DYNAMICS

Rewards
Status
Achievement
Self-expression
Competition
Altruism

Approach 2 Narrative Composition

The narrative composition model (illustration 20) is often used in movies and books, to keep the reader fascinated and intrigued, throughout the story (Pape et al. 2013). Many movies use the composition to slowly build up the story and the tension. It is an effective way of telling a story so the readers/users attention is captured from start till finish. The composition model is divided into seven parts, each taking their part of the story.

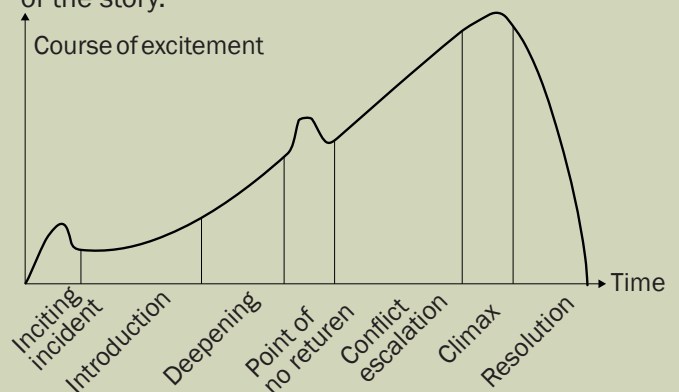

III.20: Narrative Composition Model

Output

The gamification activities address and satisfy basic human desires, creating the addictive experiences that motivate users to take specific actions and to return more frequently (Pape et al. 2013).

Research about the narrative composition model clarified some similarities between the model and

the cultivation process. A potential of enforcing these elements, in the cultivation process, and adding the missing tension elements could be interesting to investigate in the ideation, and thereafter in a test environment.

Playful Learning

Childres Cognitive Development

The diversity in age and gender in the target audience makes tricky to make a solution involving everyone. Three of the criterias discusses the sensory stimulation, learning about cultivation and the need for a solution usable for the whole family. These criterias forms the basis for an investigation about children’s cognitive learning development. To understand the cognitive learning development, research made by Jean Piaget leading theoretician within the field are examined (Whitebread et al. 2009). Below a short sum up of the key findings.

! **Project Criterias**

1. The product should give insight and knowledge about the cultivation process
2. The solution should involve and stimulate the senses throughout the growth process
3. The product should be suitable in use for children as well as adults

Four Phases of Cognitive Development



**SENSORIMOTOR
0-2 YEARS**

The child creates an understanding of the world by coordinating sensory experiences with physical actions.

Play with something



**PREOPERATIONAL
2-7 YEARS**

The child represents the world with images and words. The words and images reflect increased symbolic thinking.

Play with something and as something



**CONCRETE OPERATIONAL
7-11 YEARS**

The child can now reason logically about concrete events and classify objects into different sets of rules.

Play as something and around something



**FORMAL OPERATIONAL
11 - ADULTHOOD**

The child reasons in more abstract, idealistic and logical ways.

Play around something

III.21: Four Phases of Cognitive Development in images and words

How Do We Learn?

A dive into the child’s cognitive development confirmed the great diversity existing in their way of playing and learning.

Diving further into the subject showed the importance of learning through play. Children experiment with the world, learn the rules and learn to interact through play (Whitebread et al. 2009).

Learning through play often happens in a relation with an associative learning process. Associative learning means that the child learns

an association between two stimuli, or a behavior and stimuli. This is perceived as the ability to connect and understand the relation between an action and its reaction. This research generates new criterias for the cultivation system.

! **Project Criterias**

- Action and its reaction should be clear
- Playful approach to cultivation
- Stimulate the four phases of learning

Hydroponic Cultivation

Introduction and Objective

This section gives an overview of the elements needed to cultivate plants in a hydroponic system. The insights will form criterias for the solution to ensure the development of a functional cultivation system

Hydroponic Sum Up

To sum up shortly, a hydroponic system is soil less as shown in illustration 22. Instead, the plant grows from an alternative growth medium. The roots are placed in a liquid nutrients solution. Artificial growth lights are added to the system in order to generate photosynthesis and whereby plant growth (Cuffari 2016).

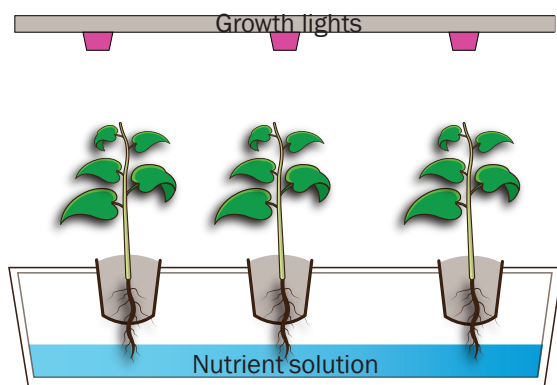

III.22: A basic hydroponic system setup

Hydroponic vs. Conventional Cultivation

Hydroponic cultivation differentiates itself from conventional cultivation in more than on way. The main different lays in the growth medium, as stated earlier hydroponic produced plants grows from an alternative growth medium.

Furthermore, the hydroponic systems normally are highly controlled to ensure the optimal growth conditions. Meaning water consumption, nutrient solvent and light settings and even CO2 insufflation are controlled and optimized for cultivating plants in a time and resource efficient manner (Cuffari 2016).

In conventional system precautions for soil based infections are need, offend the solution is pesticides and/or fertilizers to ensure 'healthy'

and strong plants. None of this is needed in a hydroponic system. The only danger for the hydroponic systems is poorly controlled environment or insect and parasite infections (Cuffari 2016).

Advantages and Disadvantages

Hydroponic system has a line of advantages which making it desirable for agriculture and consumers to apply the technology. Some of the key advantages stated in the literature is:

- Higher yield
- Up to four times higher vitamin levels
- Up to 90% less water consumption
- Controlled environment lowers risk
- Not seasonal dependent
- Saves space
- Faster growth
- No soil bacteria
- Easy to harvest

Hydroponic critics argues that hydroponics has a negative impact on the environment, due to the growth lights and the material consumption to make the systems (Despommire 2011).

Even though there are some critics, an increasing interest and implementation of hydroponics in agriculture are rapidly happening worldwide (Despommire 2011).

Basic Knowledge

Making this project different response on the hydroponic technology has been outspoken. The general perception of hydroponic cultivations is that the food produced is poor quality compared to conventionally cultivated food (Worksheet 5).

Consumers perception of hydroponic food is misguided because many of us have forgotten or never learned the basics knowledge about plants biochemistry and development. Therefore the next pages give a short description of what a plant really needs to develop.

Photosynthesis

For the plants to grow they need energy. The plants get energy from the process of photosynthesis. The plant converts light energy into chemical energy. To generate the chemical energy the plant uses light, CO₂, water and nutrients conventionally contained from the soil. Illustration 23 shows a simplified process of photosynthesis. The plant absorbs water and nutrients with the roots. CO₂ and light are absorbed in the leaves. The light is absorbed in the leaf by the reaction centers. These centers contain green chlorophyll pigments, which also makes the leaf green. In order for the photosynthesis to be possible the top of the leaf needs to be covered by the light beam. In the photosynthesis, many other reactions happen but these are the basics to consider when designing a hydroponic system (BBC 2011).

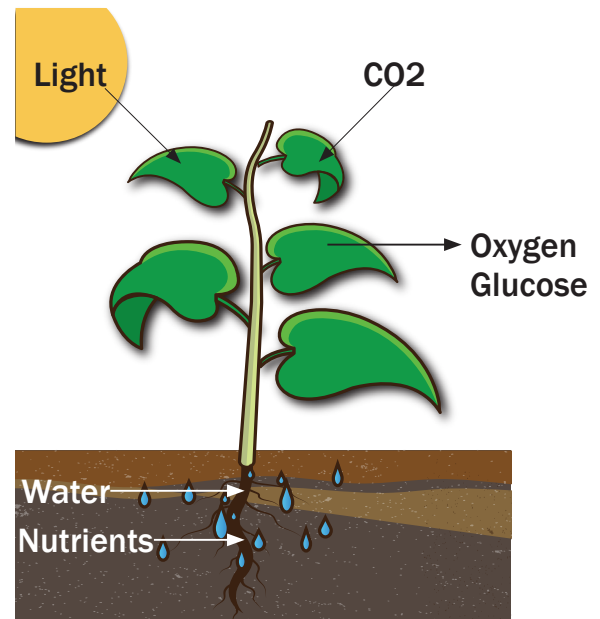

Ill.23: The basics of photosynthesis in a single plant

Plant Growth and Stages

In the plants lifetime it goes through several stages. To create appropriate growth condition it is necessary to understand the different needs the plant has in each stage. The needs can be viewed in illustration 24.

Output

The research helped to understand the basics about plant cultivation regardless of the cultivation system. Next step is to get an understanding of the requirements for a functional hydroponic system.

	Germination	Seedling	Vegetative	Growth	Reproductive
Needs	Seed needs: Water Oxygen H Heat 20-32 °C	Seedling needs: Water Oxygen for roots Light Nutrients Carbondioxide	Plant needs: Water Oxygen for roots Light Nutrients Carbondioxide Stable conditions	Plant needs: Water Oxygen for roots Light Nutrients Carbondioxide Harvesting/ trimming	Plant needs: Water Oxygen for roots Light Nutrients Carbondioxide
Actions	Make Roots Plant shoot sprouts Has tiny leafs	Roots grows bigger Leafs absorbs light Starts to grow	Develops rapidly the: Stem Branch Leafs Roots	Plant grow bigger Can be harvested	Plant produce seeds

Ill.24: The five vegetative stages in plant growth

Hydroponic System

Introduction

This section describes the elements of a functional hydroponic system. The objective is to investigate if there are any parameters in the hydroponic system, which are fixed and can not be changed or alternated without significant impact on the system performance.

System Set Up and Dimensions

Plant growth in a hydroponic system is limited by the design and construction of the system. To deal with this issue this project will focus on plants with similar morphology (growth principles). The rest of the report will focus on leafy vegetables and herbs, which both uses an aerial shoot system, meaning the stem and leaf grows above the soil.

Light

Light is one of the most important factors to generate plant growth. Optimal growth conditions in a hydroponic system requires the right spectrum and photon stream in the lights (Worksheet 19).

Philips Lighting has conducted tests on LED grow lights in order to find the optimal conditions for greenhouse cultivation. The main factors affecting the photosynthesis and the morphology of the plant is

- Light intensity
- Total light over time
- Day length period
- Light quality spectrum
- Light direction
- Light distribution
- Distance between light and plant (Echtel 2016).

Metabolize

Like humans, plants need rest to metabolize. If the plant does not get any rest, the leaf will develop rapidly and have poor nutrient values. To overcome this, the growth light should be turned off some hours through the day. Studies show a 16/8 ratio is preferable, meaning lights on for 16 hours per day and off 8 hours (Echtel 2016).

Water

Water is a crucial factor in plant growths. Elisa Majara Plantui's agriculture expert states: "In smaller gardens, I have never seen any problem with water conditions, except if there has been a bacterial infection from an external source. But in industrialized setting, there are requirements for the water quality to ensure good growth and reduce failure." (Worksheet 18). Based on this statement, the water control will be excluded from the project scope

Water Consumption

Leafy vegetables and herbs approximately consume two liters of water per six plants in one week when they are in the growth stage (Worksheet 18). The water consumption needs to be re-calculated or tested if a different setup than Plantui's is used.

Nutrients

Cultivation in a hydroponic system requires a liquid solution of nutrients to ensure the best nourishment for the plants. Normal practice is to consult with a manufacturer of nutrients to get the optimal nutrient composition and mixing ratio. Designing the nutrient solution is not in the scope of this project.

Growth Medium

A soil-less system requires an alternative growth medium. On the market a wide range of materials are available. The requirements for a growth medium is as following:

- Contain seed
- Support stem
- Aeration of roots
- PH neutral
- Moisture Retentive
- Size and shape adjustable to fit system

The four most common growth mediums are shown in illustration 25.



Ill.25: Growth mediums for hydroponic systems

System Architecture

Product Breakdown

Plantui has provided the team with four Plantui 6 Smart Gardens and seed capsules, which are used for testing and understanding the hydroponic technology. To gain greater insight into the system an analysis of the key features, composition and technology are made (Worksheet 47). In illustration 26 a short recap of Plantui's product architecture is shown.



Rockwool seed capsules



Nutrients and spoon

Overall product architecture



III.26: Plantui 6 Smart Garden product architecture and features

Needs to be tested

Some of Plantui's competitors use other principles for the hydroponic system design. This makes the team wonder if any of these configurations are applicable in the new cultivation system. Following questions has to be answered in order to obtain the optimal design:

1. Does the growth light has to be red, blue and green?
2. Is it necessary to adjust the height of the growth lights
3. Is it preferable to use another growth medium?
4. Is it needed to have an ebb and flow system?

Out of Project Scope

- Adding CO₂ to the system
- Designing nutrients
- Adding heat to the system
- Controlling water quality



Cultivation Criterias

1. The growth light should be optimized in order to make the photosynthesis process efficient
2. The system should have a 16/8 hours sleep ratio
3. The system design and dimension should fit to cultivate leafy vegetables and herbs
4. The system should indicate when it needs water refill
5. The water should circulate to oxygenate the water
6. The distance between light and plant has to be appropriate in order for the plant to grow
7. The roots should be able to absorb nutrients and water

Value Creation

What Are We Making?

Throughout the previous phases, data and insights have been collected and processed. These insights form the foundations for the project. To make the information tangible and align the team a workshop is conducted. The objective is to get a shared understanding of where the project is moving towards. Erik Lerdahl's pyramid for a Vision-based approach to design (illustration 27) is used as a platform for conducting the workshop (Lerdahl 2001).

The focus of the workshop is to generate a shared understanding of the value mission and materialize it. The interaction vision has been created in order to guide the team through decisions in relation to the overall product interaction.

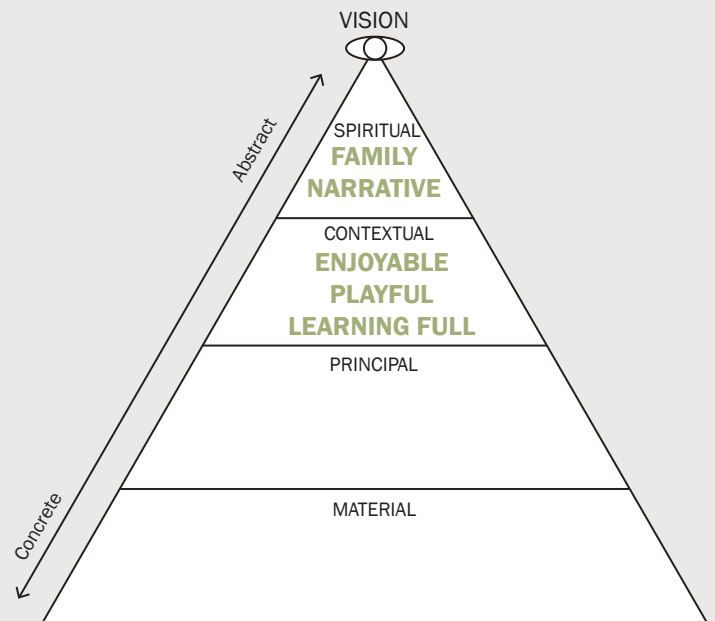

III.27: Erik Lerdahls Pyramid for a Vision-based approach to Design (Lerdahl 2001)

Value Mission

“It’s not about being self-sufficient - but to provide a set of values to your kids

- Sarah mother, two kids age 5 & 9

UNITY



Like having a family dinner where everyone talks and focus on each other

LEARNING



Like teaching your child to bike. Child and parent feel proud

ENJOYABLE



Like playing a board game with the family where everybody can participate

III.28: Value mission illustrated to gain shared understanding

Interaction Vision

Should make you feel like an experienced cultivator

PLAYFUL



In a simple way which activates the inner child

TRANSPARENT



Like a recipe, you know the process and where you will end

EASY



Feel like you always new how to do it

III.29: Interaction vision illustrated to gain shared understanding

Criteria formation

Aligning criterias

The Pleasure Model by Patrick Jordan is used to systematically generate product criterias (Jordan 2000). The Pleasure Model is used to get a holistic understanding of the target audience needs towards a cultivation system. The teams understanding of the target audience needs is formulated as sentences focusing on user characteristics and product benefits.

The sentences and the relation between user insights can be viewed in Worksheet 22. The Pleasure Model helped to define the criterias and the product properties which the users will find pleasurable to use. See the design criterias below. Next step is to generate concepts based on the criterias.

Target Audience Criteria Sum Up

- The product should invite all family members to interact with the product at the same time
- The product should give the family a feeling of being connected while using it
- The product should be suitable to use for children as well as adults
- The product should feel more like a family product than a food producer
- The product should give insight and knowledge about the cultivation process
- The solution should involve and stimulate the senses throughout the growth process
- The product should be applicable in the family home
- The product should be easy to implement and use in the busy daily life

Keep the Interest Criteria Sum Up

- Guide the family through the use and the different stages
- Using the product the family should feel like they learn new things
- User action with features should create a clear reaction

Interaction Criteria Sum Up

- Be easy to use
- Handling the product should be playful

Cultivation and Plant Criterias Sum Up

- The light should be applied in such way so the photosynthesis process run efficiently
- The system should have a 16/8 hours sleep ratio
- The system design and dimension should fit to cultivate leafy vegetables and herbs
- The system should indicate when it needs water refill
- The water should circulate to oxygenate the water
- The distance between light and plant has to be appropriate in order for the plant to grow
- The roots should be able to absorb nutrients and water
- All plants should be edible

Ideation

Ideate, Prototype, Test, Repeat

This phase gives an overview of activities made to generate a concept. Throughout this phase, the process of diverging and converging to generate ideas and explore the solution space is showed.

The phase is a mixture of developing concepts and testing them in order to get closer to a concept that will form the basis for the rest of the project. Finally a sum up of one concept which will be further developed and the criterias it needs to fulfill to meet the users needs.

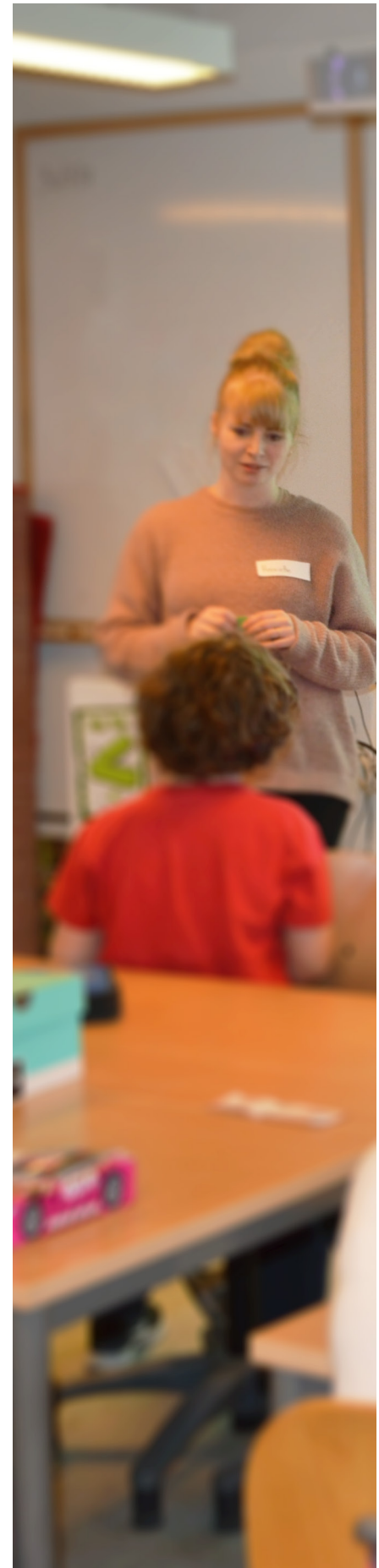



Ideation

Sketching On Criterias

The objective is to generate as many ideas as possible based on the mechanisms identified on page 26-27, the mission statement and criterias from page 34-35. The approach behind this ideation is summed up to the right.

1 & 2 Ideation - Generating Concepts

The first step in the ideation is to generate multiple ideas based on the value mission and the criterias. The output from this approach is multiple fragmented solution principles. The solution principles are combined and categorized into four themes as shown in illustration 30-33.

Approach

The approach applied to generate ideas and synthesize them into five concepts is as following:

1. Ideate on value mission + criterias
2. Synthesize to four concept categories
3. Ideate and explore the four categories
4. Act it out and deselect
5. Evaluate

Mimic Nature Clearly

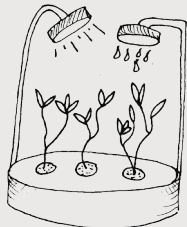

a. Mimics sun and rain



b. Enclosed ecosystem



c. Hillside farming



d. Shaped as cloud and sun

III.30: Concept a,b,c and d builds on the principles of mimicking the outdoor ecosystem

Fully Integrated System



a. Plantui look alike

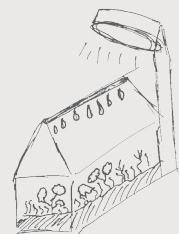

b. hydroponic greenhouse



c. Portable plant in stand

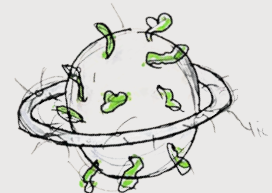

d. Plants grows out of a planet

III.31: a,b,c and d show concept where light and water are integrated in the product

Cultivation Game

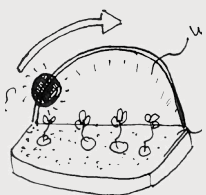

a. A farming game



b. monitor the plants and play with them on iPad



c. Board game with plants as bricks

III.32: a,b and c uses elements of gamification is added to the cultivation

Playful Cultivation

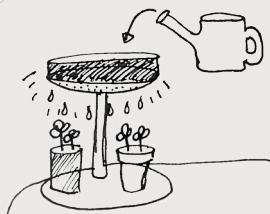

a. Fun watering



b. bouncy garden

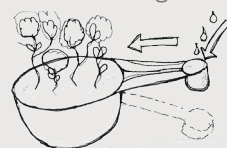

c. Tilts when it needs water

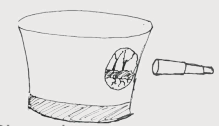

d. Binoculars to see water levels

III.33: a,b,c and d uses playful elements to make cultivation more fun

3-5 Ideate and Explore

The sketches in illustration 30-33 are undetailed making it hard to evaluate if they meet the criterias for the product. The team re-strategies by moving from 2D sketching to mockups. The mockups are based on four principles from the ideation round.

Building the mockups helped to further develop the concepts. Act it out is used to gain a better understanding of how the users will interact with the concepts. The five concepts and insights are presented below in illustration 34-38.

Concept 1

Concept 1 has a centered growth platform. The lamp is movable and moves around the growth platform. Mimics the sun and outdoor cycle.

Core principles

- Mimics sun cycle
- Mimics abstractly
- Can rain
- Round plant surface
- Automated
- Low interaction



III.34: Concept 1 Theme Mimic Nature

Concept 2

Concept 2 is a portable cultivation system for a single plant. Everything the plant needs is integrated.

Core principles

- Portable
- Contain one plant
- Round plant surface
- Automated



III.35: Concept 2 Theme Personal Cultivation Toy

Concept 3

Concept 3 is a small indoor farm where the plants layout is structured. The light and water system looks like a sun and a cloud to mimic nature.

Core principles

- Mimics nature
- Caricatures nature
- Can rain
- Structured plant system
- Manual
- High interaction



III.36: Concept 3 Theme Mimic Nature Clearly

Concept 4

Concept 4 is a small Zen garden where the plants grow wildly in a hill landscape like the plants would do outdoors.

Core principles

- Wild hill plant surface
- Automated
- Low interaction



III.37: Concept 4 Fully integrated system

Concept 5

Concept 5 is a sculpture garden focusing in the two plant pots. The plant pots can be moved in the vertical direction. The user has to move the light them self

Core principles

- Contain two plants
- Manual
- High interaction



III.38: Concept 4 Cultivation Game

Output

The act-it-out session gives a shared understanding of the concepts and helps to develop the concepts further. Some of the similarities and differences in the concepts are clarified. It can be concluded that the concepts need to be further differentiated in order to test which direction the project should move toward.

Concept 3 did not give the desired interaction in the act it out session. Never the less concept 3 unfolded a new project layer. It could be interesting to see if the idea of a Zen or sensory garden would add value to the new cultivation system. Next step is to explore and develop the concepts further.

Identity Development

Story creation

A deeper exploration and understanding of the four concepts are made through storytelling, using Dave Seah's framework (Seah 2015). The objective is to give each concept an identity and create a supplementary universe around it. A combination of verbal, written and illustrative

mediums are used to create the story around the four concepts. The stories for each concept are defined through a mood board, text and sketches as shown below in illustration 39-46.

Little Farmer



III.39: Little Farmer mood board

My Planty



III.40: My Planty mood board

Story

Little farmer gives the child some of the responsibility of the daily cooking session. He acts as a little farmer controlling his farm and ensuring the cultivation by moving the sun and watering the plants, squeezing the cloud and making it rain.

Story

My Planty is enforcing the child's confidence by allowing them to have control of the plant, and ensuring that it gets the sun and water that it needs. My Planty is a small transportable device allowing the kid to have it around in all situations.

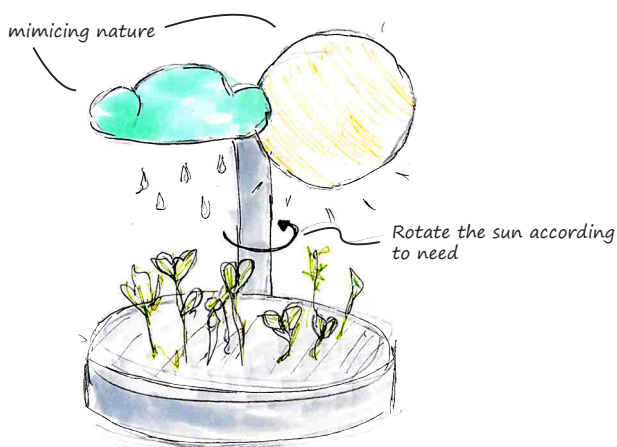

III.41: Little Farmer mimics nature and invites the children to interact

Portable plant grower with water and nutrients

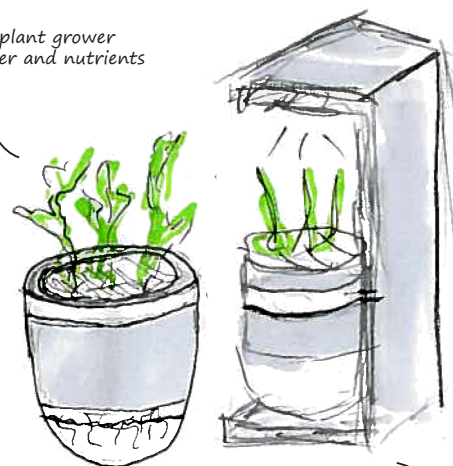

III.42: My Planty a portable plant with growth station
Growth station, giving the needed light.

Output and Reflection

Storytelling and sketches helped to give the team a shared understanding of the four concepts. Even though there are a shared understanding, the concepts still need to be evaluated and tested. Preferably the testing will be done with families to see what children as well as parent

think. The storytelling can be used to have a discussion with the target audience and to examine if the team has interpreted the users needs correctly. The testing should happen as soon as possible to push the project forward.

Xplory garden

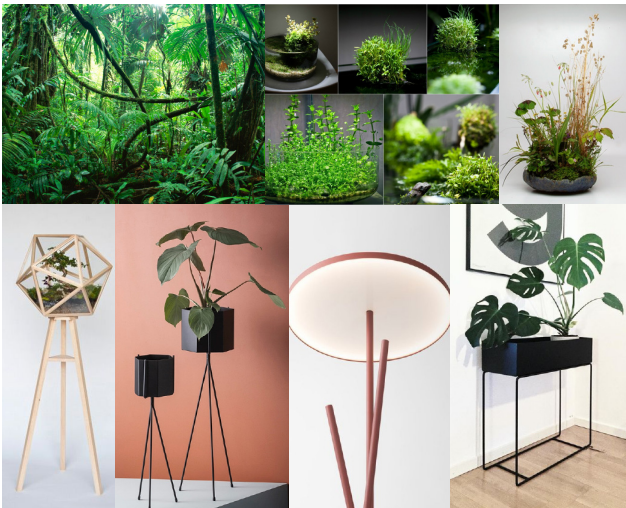

III.43: Xplory Garden mood board

Tikko



III.44: Tikko mood board

Story

Xplory is the adventures cultivation forest allowing the family to explore different continents through plants. The family ensures all the plant gets water and sun by moving the elements around according to where they are needed.

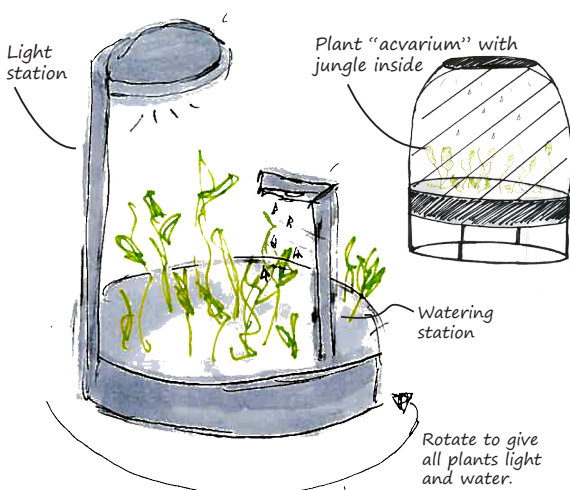

III.45: Xplory Garden mimics nature and grows a wild forest

Story

Tikko is a natural balancing tree, showing growing process of the plant in a transparent way. The user controls the "sun", and has the task of moving the sun between the two plants, and moving the plant according to its germination, which thereby becomes an interaction element.

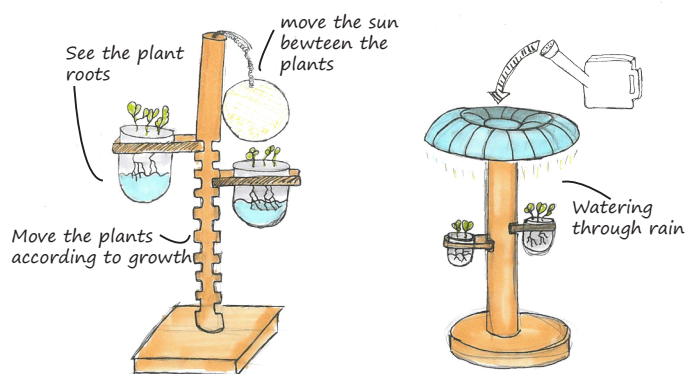

III.46: Tikko makes it like a game to take care of the plants

Workshop with 4th Grade

Introduction

It was not possible to set up a test environment with families with such short notice. However, an opportunity presented itself. One of the fellow students knows a fourth-grade teacher who is interested in a collaboration. The plan is to have a workshop with a fourth-grade class to understand how the children perceive the four concepts. Another positive outcome of the collaboration is that the team can gain more insights about children in the age span of 8-10. The main findings are presented on the following pages, to see full documentation view Worksheet 28.

Objective

The aim is to test the four concepts and gain insight about the children's knowledge about food cultivation, and if possible to identify new needs or aspects that the team has not considered yet.

Approach

- 1 Presentation:** Giving a small introduction about hydroponic cultivation and getting a general understanding of the children's level of knowledge within the area.
- 2 Explore & Play:** The class are divided into four teams. Each team uses 10 minutes with each concept prototype to explore and interact, while the design team observes their interaction.
- 3 Develop & Play:** The four teams of children has to develop the concept prototypes. The children co-develop with each other and can add or remove elements to the prototypes. Afterwards each team presented the alterations and the reasoning behind.
- 4 Data processing & Evaluation:** Back at the University, the data is processed and the workshops insights are evaluated and reflected upon.

Prototypes

At the workshop four concept mockups are brought for the children to interact with, see illustration 47-50. The four mockups are a materialization of the stories and features described and sketched on page 40-41.



III.47: Xplory Jungle



III.48: My Planty portable



III.49: Little Farmer water



III.50: Tikko game

1. Creating a Baseline

Questions asked in plenum starting the presentation:

Have you ever tried to cultivate your own food?

- All of the children had at some point tried to grow plants at home.
- They mentioned, leafy greens, herbs, tomatoes and fruit trees
- Some cultivate outdoors but a few of the children has tried to grow food indoors in a tray/plate
- There were no doubt about that the children loved to grow foods!

What do you like most about growing your own food?

Noah: "I like to grow my own food because I know its healthier and there are vitamins and no bad stuff like pesticides in it"

Christina: " I just like to see it grow"

Franz Alessandro: "I like to experiment - I once tried to remove the sunlight for a day and it died"

Moses: "I like see it grow and to make videos and follow the process of the plants growing."



III.51: Testing Xplory Jungle with children

XPLORY

“It’s a jungle” was the first reaction to Xplory. They were interested in the wilderness in the cage. All of the group members were playing with it at the same time, from all sides. There were a bit of hesitation to touch the plants through the wire. The watering was of great interest, but it had to be more controlled, to ensure the amount used. They liked that all of the plants were different and they could taste it and explore it.



III.52: Testing My Planty with children

MY PLANTY

The children were unsure on how to start using My Planty. They asked a lot of questions before trying to open it. When first overcoming the insecurity, it was easy for them to figure out the structure of the product. They knew it needed light due to the presentation and started immediately to play. All of the children were very curious about the egg shape. They did not understand how to add water and nutrients to the plant, My Planty was mainly used by 1-2 children at a time, creating an isolated interaction.



III.53: Testing Little Farmer with children

LITTLE FARMER

It was very easy for the children to understand what the different elements in Little Farmer were. Before the workshop even started they already knew that the yellow ball was the sun and the cloud was the system for watering. The children sat around the mockup and played with it all together or in parallel. They enjoyed having all the different elements so clearly and easy to interact with.



III.54: Testing Tikko with children

TIKKO

Tikko divided the children, making them interact on each side, and not around it, thereby creating two groups. The children understood that the plants could be moved but they didn’t understand why. The light or the sun, as they called it, was moved around as expected, which they enjoyed doing. The interest was quickly lost due to the simplicity of interaction, and cultivation.

Output

The main takeaways from the workshop are the children needs guidance in order to give the plants the right amount of water, nutrients, and light. The children in the age of 8-10 are very hands on. They want to touch and learn through

their hands, words and visual elements. They are not afraid of failing they are just exploring everything with great interest. They are excited all the way through regardless to if they fail or succeed.

Workshop with Parents

Objective and Approach

To gain an understanding of the parent's thoughts about the four concepts, a small workshop is conducted. The aim of the workshop is to clarify how the parents interpret the interaction with the concepts, and in which context or situation they could image the products.

The workshop is conducted as an interview. Act it out with mockups, with one parent at a time, is used to guide them through the interaction with the concepts. Two fathers from two different families are interviewed, both with children under the age of three.



III.55: Testing Xplory Jungle with a parent

XPLORY

The parents liked the idea of visiting different corners of the world through plants and having a living room sculpture that evolves. They felt that the concept was aiming at older children (above 4), but that the parents would like to interact with it. It gave a nice insight in diversity, and that plants are different.



III.56: Testing My Planty with a parent

MY PLANTY

Nostalgic, reminds them of a Tamagotchi, it seems very individual based, and thereby addressed to older children. The parents liked the idea of taking plants, which are normally very static and making them dynamic and playful.



III.57: Testing Little Farmer with a parent

LITTLE FARMER

Experience orientated, a funny way of mimicking nature, in a very childish manner. In general, the parents liked it as being a cultivation toy to their children. Something the kids could take care of. The simplification is interesting for younger children, creating a culinary landscape in the kitchen.

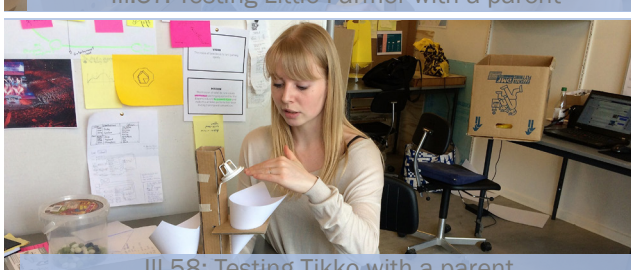

III.58: Testing Tikko with a parent

TIKKO

Very sculpture, not that child-friendly, Is more seen as a lamp than cultivation medium. The small variety and yield may result in loss of interest. It is more up to the parent to create the good story around the product, the product itself does not invite to that much interaction.

Output

The parents liked the idea of giving their children, and themselves, a better insight and understanding of cultivation. They wanted a product targeting both the children and themselves, and thereby having something they can learn around, instead of only hearing about cultivation. They especially liked the dynamic wilderness created in the Xplory concept, instead

of the structured lines created in the Little farmer. The dynamic created an association to the wilderness of nature not controlling how it grows, and not making it to sterile and thereby making it more acceptable to fail. The test with the fathers and children has made it possible to evaluate the four concepts.

Concept Evaluation

The concept evaluation is based on the criterias on page 35. Depending on how each concept is further developed the team believes they all can meet the criterias from the 'Cultivation and Plant' criteria section and the 'Keep the Interest' and 'Interaction' criteria section. Based on the insights from the test with the fourth grade the team finds this likely.

- ✓ Meets the criteria
- ✗ Do not meet the criteria
- ⊛ Has not been verified

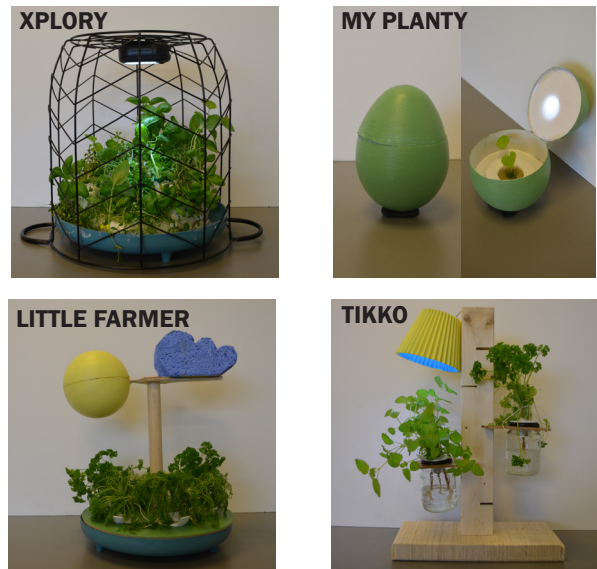

Ill.59: The four concepts

Criteria from page 35	Xplory	My Planty	Little Farmer	Tikko
1 Invites all family members to interact with the product at the same time	✓	✗	✓	✗
2 Gives the family a feeling of being connected while using it	⊛	✗	⊛	⊛
3 Be suitable in use for children as well as adults	✓	✓	✓	✓
4 Feel like a family product more than a food producer	✓	✗	✓	✓
5 Give insight and knowledge about the cultivation process	✓	⊛	✓	✓
6 Involve and stimulate the senses throughout the growth process	✓	✗	✓	✓
7 Be applicable in the family home	✓	✓	✓	✓
8 Easy to implement and use in the busy daily life	⊛	⊛	⊛	⊛

Output

Criteria 2 and 8 are not verified by the users at this point. My Planty and Tikko both has elements which do not live up to the target audience criterias. Xplory and Little Farmer lived up to most of the criterias. Based on this

it is decided combine elements from Xplory and Little Farmer into one concept. Next step is to define which parts to use in the concept and to investigate the concept further.

Defining the Concept

From Two To One Concept

Xplory and Little Farmer are combined into one concept. From Xplory the seed concept and the wild vegetation growth surface is used. From Little Farmer, the high level of interaction with water and light is used in the new concept. The balance is to investigate how directly the concept should mimic the nature in regards to the plants, the sun, and rain.



III.60: Xplory and Little Farmer

Illustration 61 shows the principle structure of the combined concept. Furthermore, the seed concept is developed as a part of the overall offering.

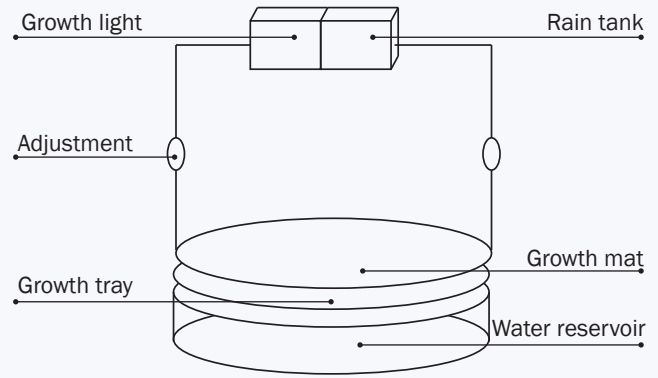

III.61: Principle structure for combined concept

Concept Mapping

	UNPACK AND SETUP	PLACE SEEDS	ADD WATER AND NUTRIENTS	TURN IT ON
USER				
PLANTS			<ul style="list-style-type: none"> Seeds starts to absorb water - germination has started 	<ul style="list-style-type: none"> Seeds germinates
THE PRODUCT		<ul style="list-style-type: none"> Contains the seeds in the best possible way 	<ul style="list-style-type: none"> The system shows it is full with water The product has a system to pour water into 	<ul style="list-style-type: none"> Turns on LED growth lights Start the first 16/8 day night ratio
HANDOUT		<ul style="list-style-type: none"> Tells the story of the mat seeds and their needs Guides the user to place the seeds correctly 	<ul style="list-style-type: none"> Tells why water and nutrients are important 	<ul style="list-style-type: none"> Tells the story about germination Tells about the 16/8 hour ratio
WORTH CONSIDERING	<ul style="list-style-type: none"> Are the product fully assembled or should this be a part of the experience? Should the product be placed in a specific room? 	<ul style="list-style-type: none"> Are the seeds integrated when buying the product or do the user have to choose seeds? How automated should the product be when it comes to watering and light settings? 	<ul style="list-style-type: none"> Do the user need to adjust any settings after the germination phase? How does the product get power? 	<ul style="list-style-type: none"> Should the products feed forward show the users when to take care of the plants/system? Is it necessary to have a feedback system to guide the users and tell if they did the task correctly?

Seed Concept

The users want to feel like they are cultivating a wild landscape or jungle as shown in illustration 62. To emphasize on this the user will buy a seed package with a selection of unknown seeds. The user buys a continent or an exploration of the continent more than a specific plant. The user has to explore and identify the plants.

The concept mapping section below investigates the relation between user interaction, product actions, and the plants. Furthermore, the section called 'handout' is used to understand what is outside the product offering.



- Scandinavia
- South America
- Asia
- South Europe

III.62: The plant and seed experience concept

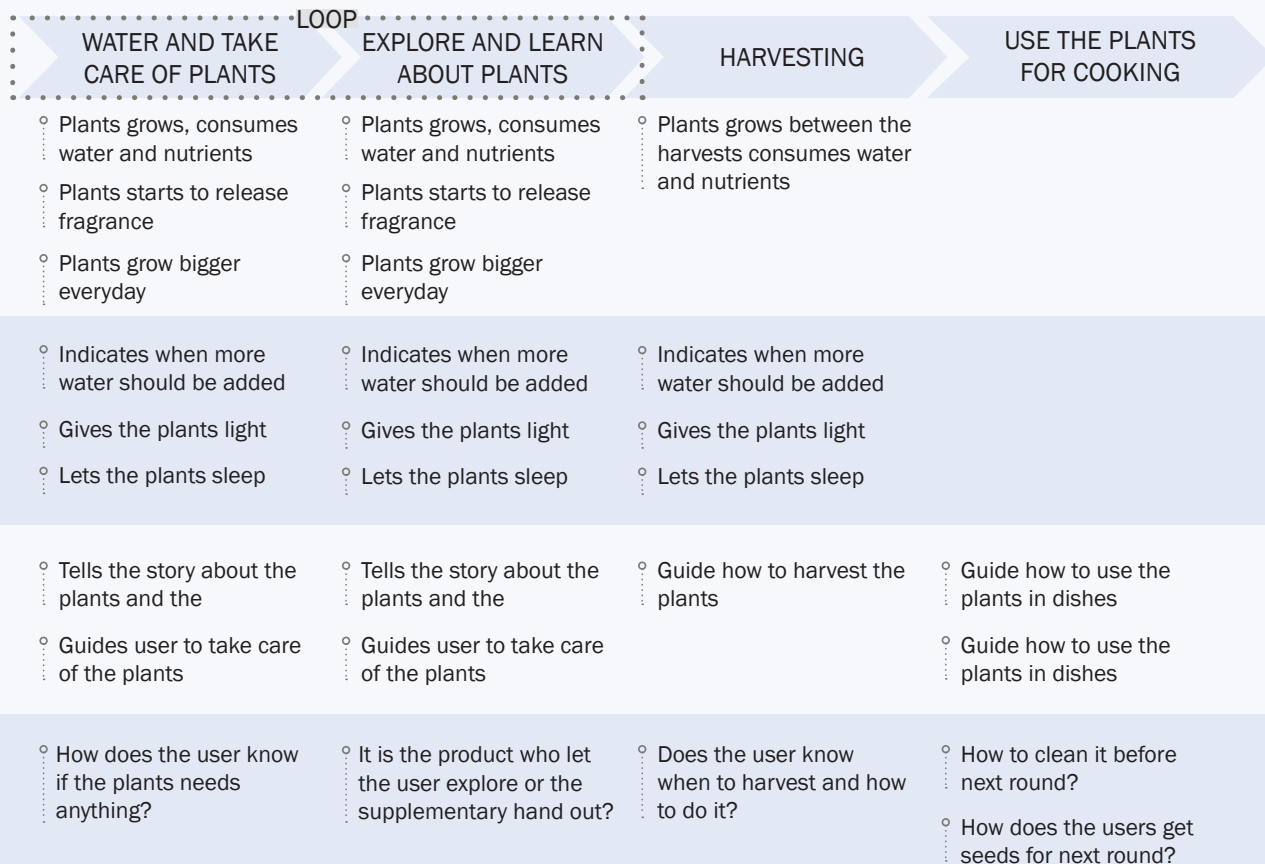

Concept Development

Background and Objective

The concept mapping helped to gain an understanding of which elements the product should facilitate but also insights into the elements there is a part of the storytelling or service around the product. Several aspects of the concept still need to be developed. The following spread gives an overview of the process and main takeaways of developing the concept.

1 Parameters to Test

The first element to test is how caricatured the mimicking of nature should be. The design team thought the children from 8-10 years old would love a very directly translation of nature into the product. This could not be more wrong. The parameter of nature mimicking needs testing with the target audience. A slider with the teams understanding of what caricatured means can be viewed in illustration 63.

Approach

The concept developing approach is as following:

1. Define product parameters
2. Develop variations of concept
3. Sum up two concept variations
4. Test concepts with users

It is challenging to determine if the product visual expression should target children or adults. To test this a slider based on the teams understanding of products, which targets either children or adults is made, see illustration 64. The two sliders are used to align the team and to generate two variations of the same concept.

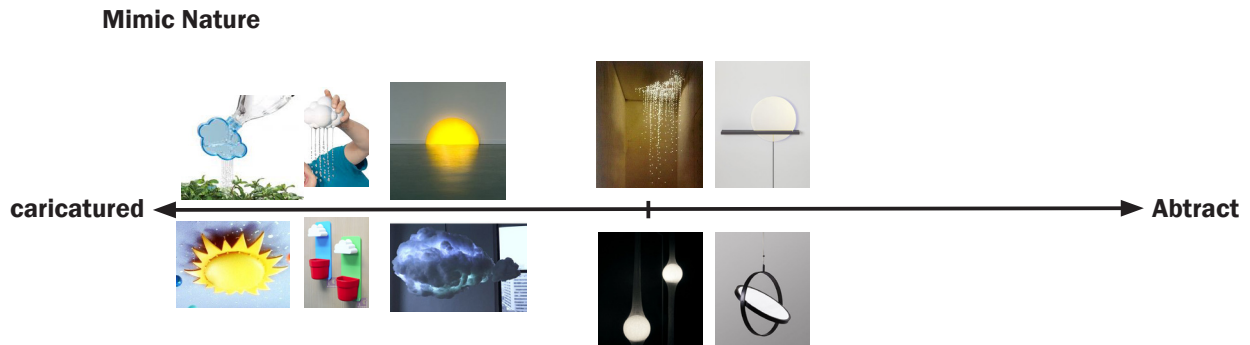

III.63: Parameters for how caricatured or abstract the mimic of nature should be

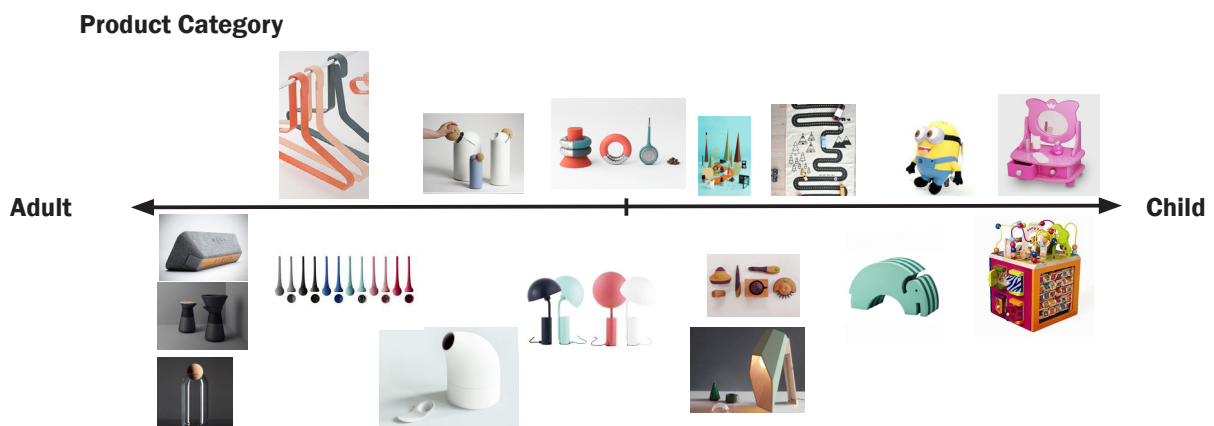

III.64: Parameters to examine if the concept should be a product for children or adults

2 Concept Variations

Another central part is to investigate how automated or manual the concept should be. In order to investigate this two concept variation are made. The concept variations are presented in illustration 65 and 66.

Sensi “We grow it together”
Aeropress Manual



III.65: Sensi a manual system with high interaction

Sensi Features

- User controls watering
- User control height of light
- User control light settings
- Interface icons
- Feedback Action Reaction - Tactile
- Feed forward icons infographics
- User has to add seeds them self

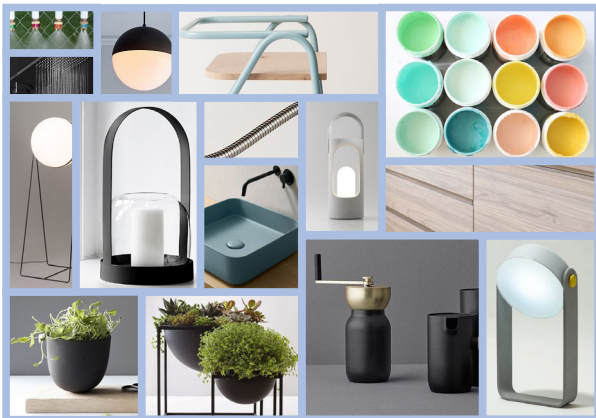

III.67: Sensi style board

Growi “I grow it for you”
Nespresso Automatic



III.66: Growi automated system with growth settings

Growi Features

- Product controls watering
- User control height of light
- Product control light settings
- Interface buttons and light
- Feedback light - Visual
- Feed forward light
- Seeds comes in prepackaged systems



III.68: Growi style board

Output

The two concepts do not vary as much as anticipated. To push the project forward, testing with these two variations has to do. One approach to accommodate this is by making mockups which are more distinct. The

supplementary material, such as style boards and the parameters in illustration 63-64 can help to initiate a discussion with users. Testing the concepts need to take place in the family home to see how the family interacts.

Proof of Concept

Background & Objective

Narrowing down to one concept makes it necessary to test if the target audience wants the concept. The previous spread explained the process of developing two variations of the same concept. This section will give a run through of the tests and the outputs from the tests. The objective is to verify what the users seek from a cultivation system. The test will help to identify if the team interpretation of user needs are translated correctly into design criterias.

Approach

The two concept-variation are tested with three families in their home.

The families are shortly presented with the minimum knowledge needed to understand the mockups. This is done to keep their perception as pure as possible.

The families interact with the product while they are asked questions about what they think.

After the interaction test, the team and family discuss the style boards, the parameters and value sliders (Worksheet 31).

The tests end with a discussion and sharing of ideas to further develop the concept.

Aspired to Test

- The families perception of the two concepts
- How the concept invites to interaction
- Interaction in general
- Semantics can they read the use
- Unidentified needs and wishes
- Style and product category
- What are they willing to pay
- Other insights the team has not considered

Test Families

Test 1 Regine 24, Lucca 2



Want it to be a lifestyle product fit into the interior
Prefer Sensi
Should be child friendly
Loves the seed concept like going back on a vacation
Would pay 300-600 DKK for the product

Test 2 Line 27, Nohr 4, Aya 2



Want it to fit into the home
Prefer Sensi
Loves the idea of creating a jungle
Would pay around 600 DKK for the product

Test 3 Susanne 40, Signe 10



Want it to fit into the interior
Prefer Sensi
Do not know what the product should cost

Concept 1 Sensi

It look like it invites the family to use it.

The pump is good because my daughter loves to water our existing plants.

I would move the light up and down on the outside of the metal stand.

I think it looks nicer than the other one.

The manual concept is not a problem I do not mind if I have to water every day.

Concept 2 Growi

It will maybe be easy because it does everything for you.

It is easy to move the light and understand how to do it.

My daughter would like to push the buttons (but this is also bad because she will push it all the time).

To closed looks like you cannot touch it.

It looks more like a furniture I do not like that.

The automated is boring but nice if we are busy.

Looks like something you are allowed to touch and interact with.

Experimental and learning elements is really good. It look like it invites the family to use it

The physical interaction with the water attracts the kids.

It looks more inviting/welcoming than Growi

Flexible in where to place it, kitchen, living room, hallway, etc.

It feels like a nice kitchen machine.

Expected success (the cultivation is not allowed to fail).

Production of food is focus when looking at this product.

Is more something for the parents to control and the kids to watch not to play with.

It is very open an easy to get near the plants

Interaction points fun for children mom and daughter agrees

It can be placed on a table or in window
They do not mind to water it once every day

Looks like you can touch it and play with it

To closed looks like you cannot touch it.

Automated is boring but nice if we are busy.

Signe do not like the automated at all there is nothing fun.

Signe want to have more interaction with the product.

Output

Valuable insights about the user's needs towards the cultivation system are gained. In general, the families liked Sensi more than Growi. The three test families liked the concept for the seeds, this will be a part of the final solution. The criterias identified through the test are showed to the right.



User Criterias

- Price between 300-600DKK
- High interaction especially with water
- Look like an interior product (style board)
- Mimic nature in an indirect way
- Be playful and invite the children to use

Detailing

Define, Develop, Test, Specify

This phase will show the process behind developing the Xplory concept. The focus is on understanding the sub-elements in the concepts and define which parts the development phase will focus on. This phase combines theory with experiments to develop and verify if the solutions work.

Furthermore, this phase discusses the manufacturing, materials and budget aspects of the product development.

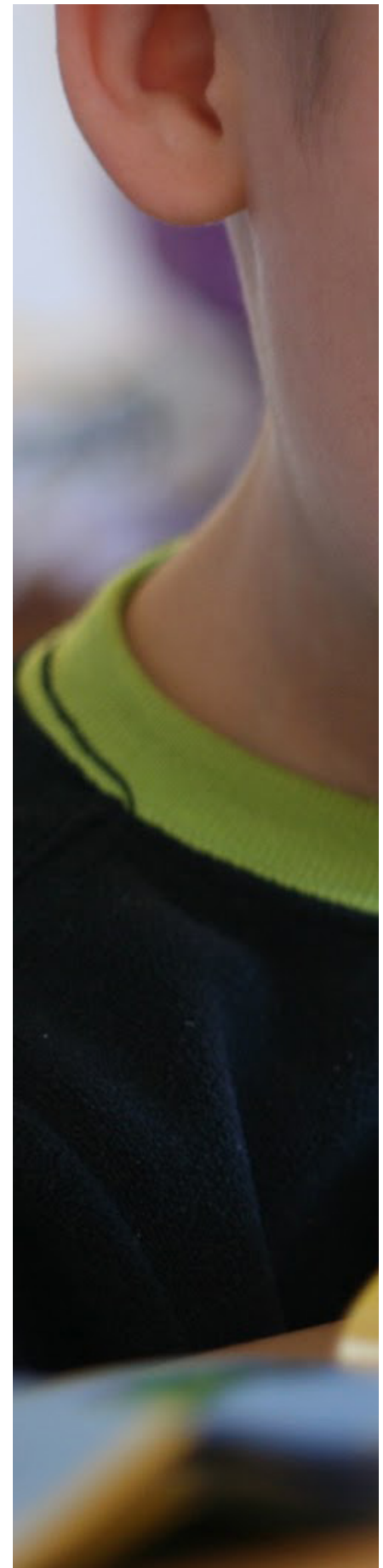



ill.72a:Boy reading

Development Strategy

Background & Objective

The user testing verified the potential of selling the Xplory cultivation system. In order for the product to go to market, the team has to make a development strategy. There are two possibilities, the first one is for the team to make a startup and go to market themselves. Another possibility is to collaborate with Plantui and use their existing knowledge, supply chain, capital and sales channels.

In the process of evaluating which approach to use a SWOT analysis of the two options is made, they can be seen below. The objective is to understand the pros and cons by choosing either of them.

Sprout startup

Strengths Knowledge about customers	Weaknesses No to low initial capital Low startup budget No brand awareness Non-existing supply chain No manufacturing facilities No distribution channels
Opportunities No limits due to existing brand	Threats Existing patents Low profit No brand awareness Hard time finding investors Bigger market players

Development roadmap

In dialog with CTO Kari Vuorinen at Plantui the team became aware of multipliable aspects of developing a product like Xplory.

The discussion with Kari helped to get a realistic overview of the project size and time frame. Furthermore, Kari gave an overview of the expenses and prices on components and manufacturing aspects. All of the insights from Plantui is useful in order to estimate the production cost for Xplory and thereby evaluate if the target price can be met. The next page recaps the early production cost estimations.

Sprout and Plantui partner up

Strengths Technology know-how Brand recognition Existing investors Established supply chain Existing distribution channels Industry network Existing patents	Weaknesses No knowledge about target audience Potential lower profit
Opportunities Short development process New customer segment Quick profit Brand awareness Broader portfolio	Threats Differentiation too little for the product portfolio Low profit Competitors

Output

There will be many obstacles if team Sprout has to go to market by them self. Two major factors are the lack of capital and suppliers.

The SWOT analysis above makes it clear that Plantui has patents, know-how, production setups, supply chain, and sales channels. Which is everything team Sprout lags. Therefore it is decided that Plantui and Sprout will partner up to get the product to market.

Project Cost

Target Price

Throughout this project, the users had set a target price they maximum are willing to pay for the product which is 600 DKK, converted to approximately 80 EUR. To make a realistic business case the project cost and the production cost needs to be realistic compared to the target price.

Production cost

The customers price limitations makes it necessary to understand how much the production price maximum can be per unit to ensure that the stakeholders still earn money on the sales.

The production price includes:

- Materials + processing
- Standard components
- Assembly
- Packaging
- Salary for production employees

From the insights Plantui gave an estimation of the production price maximum is calculated. This is shown in the table below.

Price (retail incl. VAT)	80	EUR.
Vat (25 %)	16	EUR.
Sales price (retail excl. VAT)	64	EUR.
Contribution, retail store	40% 25,6	EUR.
Sales price, PLANTUI	38,4	EUR.
Contribution, PLANTUI	25% 9,6	EUR.
Production cost	75% 28,8	EUR.

The calculation shows that the production cost maximum should be 28 EUR (240 DKK), This means the detailing and development of the concept are limited if the product should meet the target price of 80 EUR.

Development Budget

The production price is known but to make a realistic project budget the development cost has to be included in order to have a healthy business. CTO Kari Vuorinen at Plantui assessment of a project of this size is 30,000 -100,000 EUR for a fully developed product.

How much can we sell?

Plantui believes a product like Xplory can easily sell 10,000 pieces the first year if the market is ready, A pessimistic estimate would be that only 3000 pieces are sold the first year. The 3000 is compared with Plantui's worst selling product. With these numbers, it is possible to make a development budget as well as investigation of how big an investment is needed to further develop a product like Xplory.

Development Approach

The estimations of the production price per unit and the expected volume gives an indication of what the development and production cost should be to maintain a healthy business. These insight will be actively used in the development phase when making the form, choosing components, materials, manufacturing and processing methods. Furthermore, in the process of designing components and the construction of the product, reflection about assembly steps will be conducted to identify early on if the structure can be made differently to cut cost in assembly,

Output

The project team needs to work towards meeting the production price per unit on 28 EUR to hit the target price. There has to be made critical decision about features, material and manufacturing possibility to ensure the product meets the price limitations.

Next step

The Xplory concept needs to be developed further in relation to finding mechanism which can be applied to achieve all the functional features. Furthermore, the form and construction should be defined to push the development forward.

Functions & Means

Background & Objective

The production estimations from the previous page and the basic structure of Xplory forms the foundation for developing Xplory further. This section gives an overview of the main functions and the corresponding sub-functions in Xplory. Next step is to define the sub-functions and investigate how to design them to meet the design criteria's. Eskild Tjalves framework of developing products are applied to unfold the solution space and investigate potential solution principles for the sub-functions (Tjalve 1976).

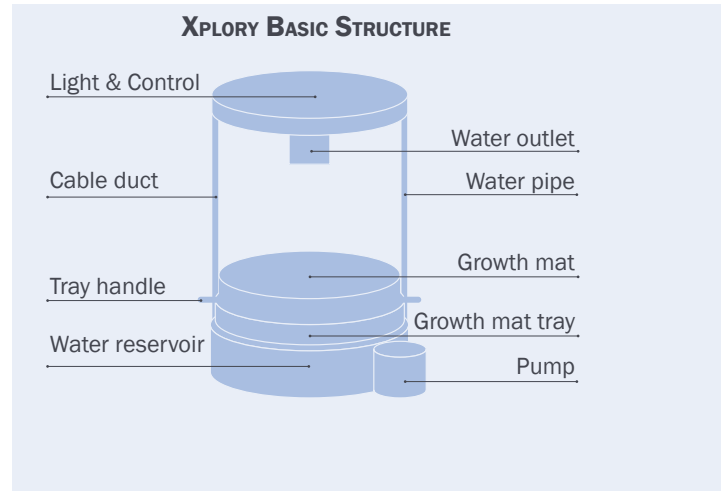

Plant tray

Growth medium

Sleep

Power

Growth light



A. Fixated B. Removable



A. Massive B. Granulate



A. Automated B. Manual



A. Batteries B. Power plug

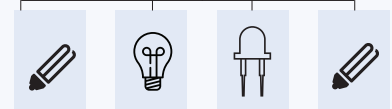

A. HPS B. Incandescent bulbs C. LED D. Fluorescent lights

A ✓
 + No water splashing
 + Watch roots
 - Cleaning

B ✗
 + Watch roots
 + Cleaning
 - Water splashing

A ✓
 + Easy to control
 + Pre added seeds

B ✗
 - Hard to control
 - Add seeds yourself

A ✓
 + Works always
 - Extra electronics

B ✓
 + Less electronics
 - User can forget it

A ✗
 + Transportable
 + No wire mesh
 - Change batteries
 - Construction
 - Run out of power

B ✓
 + Standard component
 + Always power
 - Not transportable
 - Wire mess

A ✗
 + Vegetative growth
 - Expensive
 - Short-lived

B ✗
 + Cheap
 - Needs sunlight still
 - Large

C ✓
 + Small
 + Spectrum adjustable
 + Flexible in design
 + No heat emission
 - Price

D
 + Germination
 + Cheap
 - Large

- ✓ Accepted
- ✗ Discarded

Plant support



Support plant growth and development

Sleep ratio



Create conditions for plants restitution and photosynthesis

Growth Light



Ensure plant growth regardless to position in the home

Watering



Keep the plants watered

XPLORY MAIN FUNCTIONS

Pump

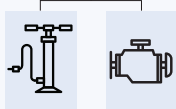

A.Manual B.Automated

Water hose

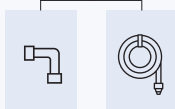

A.Embedded B.Plastic tube

Water distributor

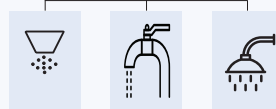

A.Nozzle B.Faucet C.Sieve

Pump Activation



A.Horizontal B.Squeeze C.Vertical D.Rotational

SUB-FUNCTIONS

MEANS

- A** ✓
 - + Cheap
 - Forget to water
- B** ✗
 - + Don't forget to water
 - Expensive

- A** ✗
 - +Less assembly
 - Complex construction
 - Open system
- B** ✓
 - + Prevents leakage
 - + Replaceable
 - + Closed system

- A** ✓
 - +Feeling of rain
 - +Easy to control
 - +Standard component
 - +Moisturizes mat
- B** ✗
 - Destroys plants
 - To much water
- C** ✗
 - To much water
 - Hard to control

- A** ✗
 - Not intuitive
- B** ✗
 - + Intuitive
- C** ✓
 - + Intuitive
- D** ✗
 - Not intuitive

Output

The function-mean-tree gives an overview of the applicable means for realizing the sub-functions. The basic structure of Xplory remains the same. Xplory's total form needs to be investigated in order to determine how the functions should be connected.

Furthermore, all of the components still needs to be specified and developed the following page will show the development process.

Form Variation

Background & Objective

At this point, the product architecture and the interconnection between functions are roughly defined. Next step is to investigate the form of the product and clarify the interconnection between functions. The main objective is to find a form which enables the functions to be ergonomic and aesthetic for the user. Furthermore, the form should be producible and fit for assembly.

Approach

Tjalve's framework for investigating form variations are applied to explore different solutions to connect the functionalities (Tjalve 1976). The first step is to diverge and investigate multiple form variations. The aim is to examine if there are one form category more suitable to meet the design criteria's than others. The investigation consists of the following steps:

1. Ideation based on style boards (Diverging)
2. Choosing form principles (Converge)
3. Inspiration trip (Diverging)
4. Mock-ups in Solid Works (Converge)
5. Refining (Converge)

1. Ideation

The first step to developing the form is to ideate on different form principles. The style board from page 49 illustration 67 helps to give the team a shared understanding of the target audiences desires towards the expression and aesthetics of Xplory. This ideation focus on opening up and investigating different form principles.

The output can roughly be divided into three principles

1. Structural
2. Organic and soft
3. Geometric controlled.

The principles can be viewed in illustration 72-74.



III.72: Structural principle: a. structural pole in the middle, b. grid formation

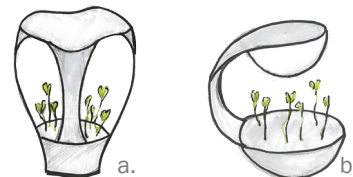

III.73: Organic principle: a. organic frame encloses the plants, b. organic expression

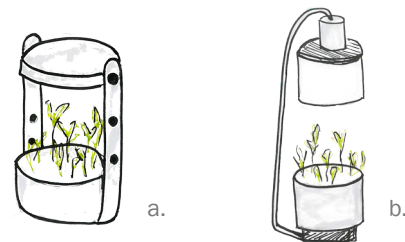

III.74: Geometric principle: a. geometric simple shapes, b. geometric with structural element

2. Form Principle

The team decided to use the form principles of geometric controlled and structural.

The form principles are defined by geometric expression with rounded edges, with a structural link between top and bottom. All functional surfaces are vertical. Massive top and bottom structural elements to create a stable structure that still seems inviting and light.

3 Inspiration trip

After working with the form for some time, new inspiration was needed. The struggle is to get the composition of the different functions and functional surfaces to fit together and complement the overall form instead of working against it. The inspiration trip to Sinnerup and Imerco is to see how other products works with making an integrated form when dealing with various functions.

4. Mockup in Solid Works

The form and the composition of Xplory are still challenging the team. A new approach to working with the form is to mock it up in 3D in Solid Works to get a realistic relation between proportions and dimensions. The hand sketches have not been detailed enough to evaluate these elements. In Solid Works, several iterations are made.



Ill.75: a,b,c and d form variations made in Solid Works

Iteration d. in illustration 75 is selected to develop further because it solves the functional issues in a more elegant way than the other iterations. Before developing the form further, a mock-up in scale 1:1 is made out of cardboard, in order to identify if the proportion and dimensions are as anticipated. The 1:1 mock up proportion and dimensions were as expected.

The interaction, on the other hand, was not as playful as anticipated. Furthermore, the integration of the pump is problematic from a production point of view. The mock-up clarified that a central function was missing. The concept lacked an indicator and a place to fill in water when the reservoir is empty.

5. Refining

A new iteration of integrating the pump and adding a system for indication water need and filling the reservoir are made. Furthermore, the criteria of making Xplory more playful are worked with simultaneously. Illustration 76 show the form iterations and how the team works with integrating the functional elements.

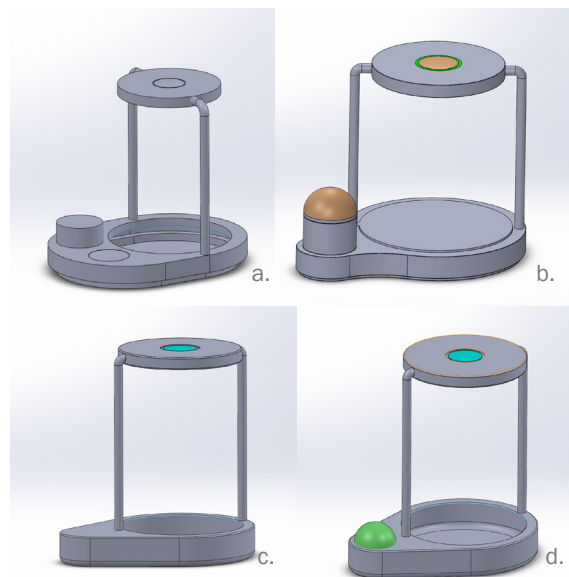

Ill.76: a,b,c and d form variations of the same form concept made in Solid Works

Output

The 3D modeling helps to identify the proportions and to get an idea of how and where the functional surfaces meet. Some of the forms from the hand sketches did not work when they were mocked up in Solid Works. Therefore the rest of the form iteration are made in 3D to push the development forward.

Defining the form helps to set the frame for the rest of the development. The next pages go through the development and specification of the features and functional elements.

Note: The development of the form and functional elements happens simultaneously through out the detailing phase.

Plant Support System

Background & Objective

This section will give an overview of the development of the seed system and plant support system. The design of the plant support system will affect the dimensions of Xplory and the dimension between components. This section gives insight into the reasoning process of designing the plant support system. The objective is to specify the growth medium, the growth tray and how the jungle feeling can be achieved.

Jungle Experience

Creating the jungle experience is one of the intangible parts of designing Xplory. The jungle experience was early in the development expected to be achievable through the trays geometry, by creating a variation in the landscape, see Worksheet 53. A rapid test showed that the jungle experience is achievable by combining the plant variations in the right way. Therefore the plant combination possibilities are investigated.

In order to understand how the vegetation should be designed the team went to a store selling herbs and leafy vegetables. The plants are set up on a tray to create the jungle experience. Illustration 77 shows one of the combinations.



Ill.77: Plant combination of curry, red basil, basil, oregano, lemon balm and thyme

Plant selection

To create the jungle experience and meet the design criteria a specification of how to choose plants are made.

1. Should be fast-medium growers
2. Leafy greens and herbs
3. Edible plants
4. Five plants variations in each seed mat
5. Plant should grow in cluster
6. No visible spacing between the plants

If the seed mats designed after the specifications it will be possible to cultivate the plants in the same system simultaneously and create the jungle experience.

Growth medium size

Specifying the size of the growth mat is done based on two parameters:

1. Needed height of the growth medium to support the stem and roots to stand upright and
2. The desired amount of plants.

To accommodate the five plants, the plant mat is 185 mm in diameter and there has to be a 25 mm edge to ensure that the plants do not get too far away from the light and do not hang out of the product. Furthermore, the plant mat has to be minimum 25 mm in height to support the stem.

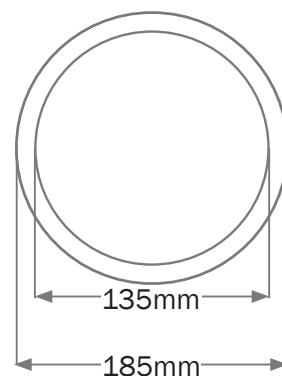

Ill.78: Seed mat diameter for the mat and the seed area

Growth Medium Material

Earlier on a decision of using a massive material for the growth medium are made. There are a few options to choose from to make a suitable decision a matrix with the relevant parameters and potential materials are made.

	Rockwool	Coco Peat
Price per square meter	52 DKK	77 DKK
Moisture retentive	✓	✓
Aeration of roots	✓	✓
Size adjustable	✓	✓
Will not degrade over time	✓	✗
PH balanced	✓	✓
Renewable	✗	✓

✓ Yes ✗ No

Based on the matrix Rockwool is selected for the growth medium. Plantui already uses Rockwool and therefore has a supplier and knowledge about using the material as a growth medium.

Plant tray

The plant trays main function is to contain the seed mat and to let the users lift the seed mat to view the roots. To achieve this there are some general requirements for the tray.

Requirements

- 1 Contain the seed mat
- 2 Support the seed mat
- 3 Fit into reservoir
- 4 Provide visibility to the roots when lifted
- 5 Be removable

In the development process, multiple iterations are made for how to place the tray in the water reservoir. The output from this is a system where the tray is placed in an insert made in the reservoirs top plate, see illustration 79 and 80.

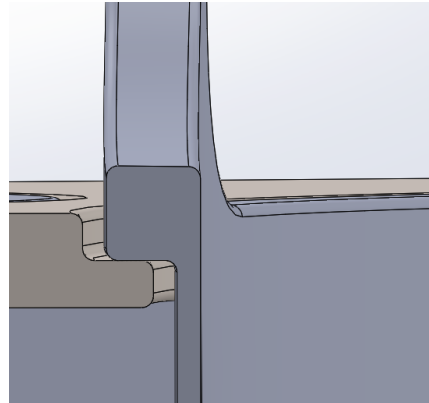

III.79: Zoom on tray inserted in the reservoir

To meet requirement 1, 2 and 3 the tray is round to ensure the mat is supported. An edge is made to support the mat from the sides and from the bottom, see illustration 80.

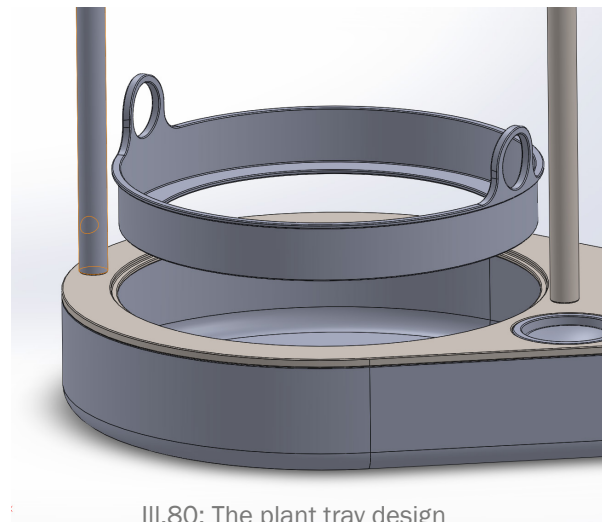

III.80: The plant tray design

To meet requirement 4 and 5 the tray is removable. Furthermore, two handles have been added to invite and enable the user to lift the tray to see the roots.

Output

The tray system meets all of the requirements but still needs to be tested and further developed to optimize it for production. The seed mat specification will ensure a working cultivation system and give the jungle experience if constructed as specified.

Watering System

Background & Objective

The system for watering is one of the key functions to make Xplory work. The function-mean-tree on page 56-57 unfolds the sub-functions which need to be developed. The development, key tests, and specification for the watering system are showcased on the following spread.

Water Reservoir

The main objective of the water reservoir is to contain water to nurture the roots and to contain excess water from the manual watering system. There are three requirements for the reservoir.

Requirements

- 6 Contain minimum 1,5 liter of water
- 7 Contain the plant tray and mat
- 8 100% water tight at all times

Using the 3D drawing of Xplory it is possible to retract the volume of the water reservoir. Without any of the other components, the water reservoirs volume is 2,8 liter. To ensure that the reservoir can contain 1,5 liter the volume of the other components taking space in the reservoir has to be withdrawn from the 2,8 liter. The calculations in Worksheet 51 shows that there are 1,8 liters in the reservoir and therefore it fulfills requirement 6.

To achieve requirement 7 the development of the plant tray and reservoir has been done simultaneously. The plant tray is designed to rest on the edge of the top plate as shown on the previews page in illustration 79 and 80.

Requirement 8 can not be tested before there are made a prototype. Developing the reservoir and constructing it considerations of how to join the base with the sides are made. The solution is that the base and the sides are made in one piece by deep drawing it to assure a 100% water tight joint.

Filling the Reservoir

- 9 Watering hole minimum 40 mm in diameter
- 10 Indicate the water levels

The user needs some kind of indication of if the reservoir is emptied. On page 38 illustration 33, the first principles of the water indication system were identified. In the process of making the indication system, a floater system was developed see illustration 82. The floater follows the water levels and through this principle, the users can read if the system needs water. The floater is a low-key and cheap solution which fulfills requirement 10.

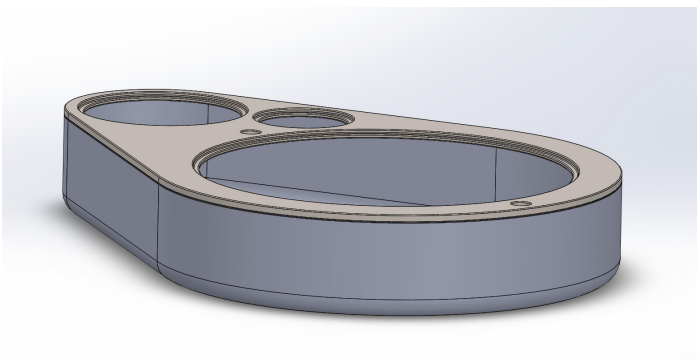

III.81: Water reservoir with top plate

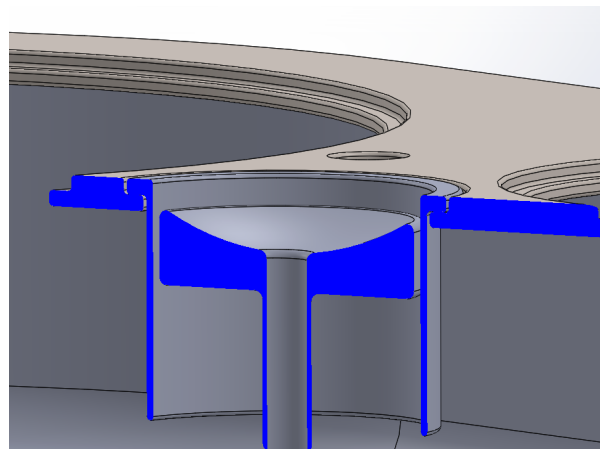

III.82: Floater in the watering pond indicates when the system needs water

Manual Pump System

The users really want the manual watering system and enjoyed the idea of pumping and thereby making it rain on the plants. Therefore a watering system needs to be developed. The requirements for the watering system are:

Requirements

- 11 Move water from reservoir to nozzle
- 12 Be activated by a vertical functional pump
- 13 Activated by the force of the hand
- 14 Oxygenate the water
- 15 Water should look like misty rain

To develop the pump system, simple displacements pumps were researched about and disassembled, see Worksheet 43. This gives an understanding of the different pumping and activation mechanism. Illustration 83 shows the water flow system the pump should deliver. In order to make a pump which can meet requirement 11 a functional model is made and tested.

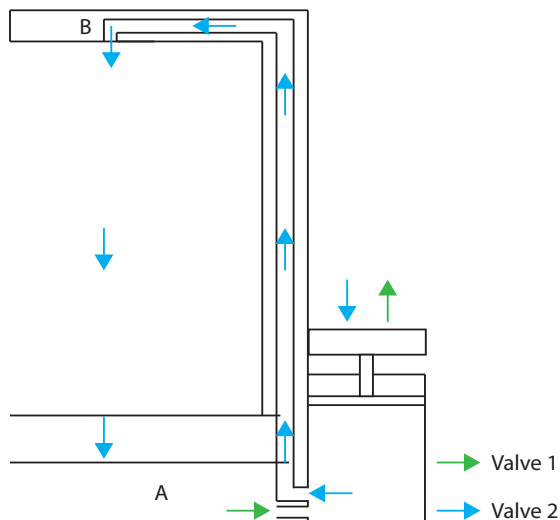

III.83: Pump system working principle

Test Setup

The displacement pump is made from a syringe, two one-directional valves, two tubes and a nozzle as shown in illustration 84.



III.84: Testing Xplory's pump system

Building a displacement pump in the approximated dimensions as what is needed in Xplory clarifies that the water can be transported from the reservoir to the nozzle using a syringe piston containing 10 ml of water. The same principle is used in Xplory.

Pump Handle

The pump is activated by the user activating the pump by pushing it down. In the process of constructing the round ball handle, a problem occurred. The shape makes it hard to understand if the pump is activated or not, see illustration 85.

A soap dispenser uses this principle. To learn more about this two soap dispensers are disassembled to see how they work. The pump needs a spring to push the handle back in the starting position.

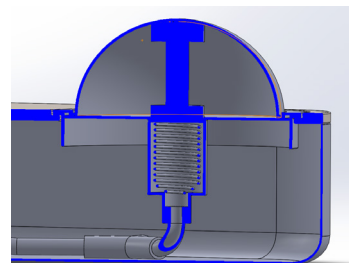

III.85: Pump activation system

Output

Developing the water system some of the elements is tested and others still need testing. The pump system works but the ball handle needs further testing to see how much pressure the user needs to apply to activate the pump. Furthermore to see if the user understands the intended semantic.

Light System

Background & Objective

The light system consists of three main categories. The growth light, the day and night mode and the power unit. This section gives an overview of how these elements has been specified

Requirements Light LED

16 Generate plant growth

Research revealed that the target audience is not concerned with how long time it takes for a plant to grow. Therefore it is interesting to investigate if Plantui's optimized growth light is the only option to make the plants grow. It would be beneficial to use cheaper LED's to keep the production price down.

Furthermore, it is interesting to examine if the light has to be adjusted in height throughout the growth cycle or if the light can be fixated in the same position an still get the plant to grow,

The user research also verified that users are skeptic about growth light when it is purple. Therefor it is interesting to see if the plants will germinate without the purple light or any other helping aids.

Test Setup

To test the growth light a small experiment is conducted with the markets cheapest growth system from IKEA named Bittergurka and with the Plantui 6 as shown in illustration 86.



Ill.86: Test setup to the left IKEA'S product to the right Plantui's product

IKEA Light spec

Light height 300mm
No sleep mode
No water pump
No ebb flow system
Red and white LED

Plantui Light spec

Light height 300mm
Sleep mode
Water pump
Ebb flow system
Red, green blue LED

Test output



Ill.87: Plants development after five days IKEA to the left Plantui to the right



Ill.88: Plants development after 16 days IKEA to the left Plantui to the right

Germination happened simultaneously after two days. After a few days, the plants developed a bit differentially. The plants in the IKEA system has a more compact morphology and develops bigger leaves. In Plantui there are fewer leaves but the plants develop and get bigger. The Ikea grows bigger plants faster but they look more unhealthy compared to the plants in Plantui. The plants in IKEA's system do not get sleep and thereby do not have the conditions for metabolizing.



Criteria

Sleep mode is needed

17 300 mm distance between plant and light

18 Need three LED stations with light spreader

19 Light spectrum as Plantui phase 3 Worksheet 47

Sleep mode

As stated earlier in the report the plants need to “sleep” preferably in a ratio 8 hours sleep 16 hours light. Therefore the systems need a sleep mode. The sleep system consists of and button for user control. A light interface to give the user feed forward and feedback about the cycle. Furthermore, the growth light will give feed forward and feedback.

In the process of defining the system, two elements are designed both the flow chart and light interface needs further development an testing to ensure the user understand the feed forward and feedback system.

1. Flowchart over events (Worksheet 47)
2. Light feed forward and feedback.

Requirements

- 20 Light off 8 hours per 24 hours
- 21 Lights on 16 hours per 24 hours
- 22 Indicate if the light are on or off

PCB and Control

The system needs a circuit board (PCB) to control the electronic components hereunder the lights on/off automation and the light interface. The PCB has to be designed in a way which makes it possible to have the switch, light diodes and the controller for the Sleep and Day mode system. Furthermore, the PCB should contain the LED diodes for the growth light.

The PCB should be connected to the power unit. In collaboration with Igor Syrytsin Engineer in electronics and wireless communication, the circuit board is verified if it can work. The design of the circuit board requires multiple processes to manufacture it which potentially can make it more expensive.

Specifying Power unit

Xplory needs a power unit to provide power for the growth light and the interface. The power cord runs trough one of the tubes and is fixated in the PCB.

Requirements

- 23 Fit into the power tube
- 24 Deliver power to LED's and Light interface
- 25 Transformer from 230 volt to 12 volt

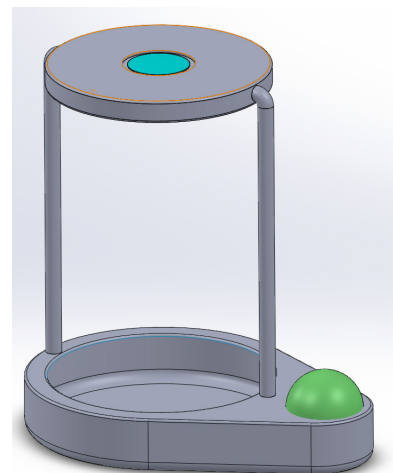

III.89: Power pipe to ensure the power cord to be fixated and safe in use

Output

Testing the lights are based on exiting products. By using the specifications from this spread the plants will grow. The interface for feed forward and feedback still needs developing and testing in order to ensure the semantics of the interface is understandable.

Materials and Manufacturing

Background & Objective

This page gives an overview of the material and manufacturing considerations for the components in Xplory. The objective is to map out the components, materials, and understand how they should be manufactured.

Component Group 1 Metal

Component	Material	Process
Lamp screen top	AISI-316	Deep drawing
Lamp screen bottom	AISI-316	Water milling
Reservoir	AISI-316	Deep drawing
Reservoir top	AISI-316	Water milling

Material Description Metal

AISI-316 also known as austenitic stainless steel is chosen to the metal parts. Austenitic steel with the right alloy is corrosion resistant and can handle to be underwater.

The material is good for cold processing and therefor it is good to deep draw. Austenitic stainless steel is fit for welding and it does not form martensite in the heat effected zones. Milling and cutting are not as good in this material but is manageable Pedersen 1999).

Component Group 2 Plastic

Component	Material	Process
Tray	ABS	Injection molding
Floater	ABS	Injection molding
Cylinder	ABS	Injection molding
Pump base	ABS	Injection molding
Pump top	ABS	Injection molding
Button	ABS	Injection molding

Material Description Plastic

ABS is used for the plastic components because of its stiffness and strengths, which is especially important in the tray. ABS can come in a wide range of colors. Furthermore, ABS is easy to machine and fabricate (Jensen et al. 2000). Plantui already uses ABS and has the material and manufacturing contact in their supply chain (Worksheet 47).

Corrosion and Surface Treatment

To prevent corrosion different techniques can be applied. For Xplory all of the surfaces will be painted and heat cured to enforce the paint. Xplory may need to be galvanized before painting it to prevent corrosion this has to be examined.

Component Group 3 Standard Components

Component	Supplier
Metal pipes	www.jemogfix.dk
Bolts and nuts	www.boltdepot.com
Plastic tube	www.petmountain.com
Nozzle	www.alibaba.com
Valves	www.alibaba.com
Spring	www.fjedre.dk
LED	www.lumileds.com
Light ring	www.lumileds.com
(PCB) not standard component	outsourced

Discussion

The information about the materials is based on research on products with similar requirements for materials. The materials used here will most likely meet the functional needs.

In order to make Xplory cheaper, it can be beatifically to investigate further if there are cheaper materials which can withstand to contain water and nutrients without degrading over time. Another option is to decide how fast it is acceptable for the product to degrade in order to find material which is cheaper.

Evaluation

As shown on the table Xplory 19 of the 25 requirements for the functional aspect. The remaining six requirements Xplory does not fulfill still needs testing or verification.

The criterias originally from page 35 and 51 focus on interaction, experience and the value proposition in Xplory. Some of the criterias have been possible to verify and some are still in the process of verifying.

✓ Meets the Requirement

Ⓣ Needs testing

Target Audience	
A	The product should invite all family members to interact with the product at the same time Ⓣ
B	The product should give the family a feeling of being connected while using it Ⓣ
C	The product should be suitable in use for children as well as adults Ⓣ
D	The product should give insight and knowledge about the cultivation process ✓
E	The solution should involve and stimulate the senses throughout the growth process ✓
F	The product should be applicable in the family home ✓
G	The product should be easy to implement and use in the busy daily life ✓
H	Cost Maximum 600 DKK ✗
Keep the Interest	
I	The family should feel like they learn new things Ⓣ
J	User interaction with features should create a clear reaction ✓
Interaction	
L	Guide the family through the use Ⓣ
M	Be easy to use Ⓣ
N	Handling the product should be playful Ⓣ

Product Evaluation

Plant Tray	
1	Contain the seed mat ✓
2	Support the seed mat Ⓣ
3	Fit into reservoir ✓
4	Provide visibility to the roots when lifted ✓
5	Be removable ✓
Water Reservoir	
6	Contain minimum 1,5 liter of water ✓
7	Contain the plant tray and mat ✓
8	100% water tight at all times Ⓣ
Water Pond	
9	Watering hole minimum 40 mm diameter ✓
10	Indicate the water levels ✓
Pump	
11	Move water from reservoir to nozzle ✓
12	Be activated by a vertical functional pump ✓
13	Activated by the force of the hand Ⓣ
14	Oxygenate the water Ⓣ
15	Water should look like misty rain ✓
Growth Light	
16	Generate plant growth ✓
17	300 mm between plant and light ✓
18	Three LED stations with light spreader ✓
19	Light spectrum as Plantui ✓
Sleep Mode	
20	Light off 8 hours per 24 hours ✓
21	Lights on 16 hours per 24 hours ✓
22	Indicate if the light are on or off Ⓣ
Power Unit	
23	Fit into the power tube ✓
24	Deliver power to LED's and Light interface Ⓣ
25	Transformer from 230 volt to 12 volt Ⓣ

Project Closing

Concluding Remark

Through the development process, the project focus has been to design a hydroponic cultivation system for Danish families. The product focuses on giving the families an enjoyable time together while cultivating greens. The families live a busy and to times stressful life, full of multiple activities, therefore the solution has to take the families need and wishes into consideration. The design process has led to Xplory Jungle, a hydroponic cultivation system enabling the families to learn about food cultivation in a playful way.

Xplory is designed to let the family interact and use the sense to explore plant cultivation. A seed concept is developed, as a supplement to Xplory. The concept consists of four continental based seed selections, which are unknown by the user. A part of the experience is for the families to identify the plants by using their senses.

The research in this report shows that the families have a hard time recalling basic knowledge about cultivation. As part of the experience, a Xploration Book is included in the Seed selection. The book creates a universe around the seed, informing and guiding the family through the cultivation experience.

The families lack of cultivation knowledge and lack of understanding for what the plants' needs, developed a need for a system which mimics conventional cultivation as they know it. Meaning, that a clarification of how to water, add light and nurture the plants was needed. This is incorporated in Xplory as a Rain and Pumps system where the user needs to activate a pump which creates a misty rain on the leafs. The lights are fixated and configured to follow a day/night cycle. Furthermore, the seed mat system is developed to mimic the wild and compact vegetation seen in nature. The concept proposal meets the functional requirements of a functional hydroponic cultivation system, this has been verified through testing and feedback from Plantui.

Plantui were involved in the project to get a

better understanding of the business potential. Plantui is imagined as the producer and vendor of Xplory. Xplory still needs further development and testing to lower the production price and verify the remaining untested criterias, before being ready to hit the market.

Process Reflection

In the first phases of this project, five project success criterias was defined. This part of the report will evaluate and reflect upon if the Xplory concept proposal meets the success criterias.

1.The target audience want to use the cultivation system.

Through interviews and user tests, it has been verified that families, adults as well as children have a great interest in Xplory. Through a statement based verification, it is clear that the families want to use Xplory. The families statements do not verify if the families want to buy or use Xplory over a longer period of time.

2.The cultivation system can be operated by adults as well as children.

To verify this criteria a 100 % a functional prototype of Xplory has to be made and tested with the families. Throughout the design process, sub-element and functions have been tested with either adults or children. The test of sub-element gives an indication of Xplory will work but in order to meet the success criteria, the sub-functions has to be tested by prototyping Xplory.

3.All family members can interact with the cultivation system at the same time.

Xplory meets this criteria. Testing mockups with the families, showed it was possible for all family members to interact at the same time. A reflective comment on this is the families can interact at the same time but most likely they will interact more fragmented in a shorter period at a time.

4. Developed a cultivation system where the plants can grow.

Tests have been conducted to verify if the plants can grow in the Xplory device. The test shows that the Xplory configurations will ensure plant growth. It is still needed to test the growth in the Xplory prototype to see if the fragmented test done throughout the project has any errors which have not been identified.

5. Users have learned new things about cultivation and/ or plants

The families interviewed states they have learned new things about cultivation or plants while testing mockups and early concepts. This verifies that the Xplory system will enable the families to learn new things about cultivation or plants.

The five success criterias has been accommodated. Some of them have been verified better and more thoroughly than others. Nevertheless the tests indicate that Xplory meets the success criterias. Further work will develop Xplory and test the elements which still lags verification.

Process Reflection

The decision of working with families as a target audience, was among others things, made on an assumption of it would be easy to establish a test environment. This could not have been more wrong. It was a challenge to establish a test environment because the families live a busy life and had a hard time to see what they could bring into the project. Even though this was an obstacle test families were eventually found. The family test environments established was of varying quality.

Some of the test conducted with families ended up being statement based, mainly because of two things, firstly the families were shy and afraid of giving wrong answers. Secondly, the material presented in the tests reflected highly the level

of feedback and discussion with the users. The first tests conducted without any materialization of the project ended in being statement based. Reflecting back on this, it would have been beneficial to materialize the project much earlier to faster be able to see if the user needs were translated correctly into product features.

There is no doubt about the project pushed forward every time the team build models or was in contact with users. It helped to learn and gain insights rapidly but more importantly, it gave a foundation for discussion and the possibility of testing if the project was moving in the right direction.

Planning and Structure

There have been very few planning guidelines from the studies in this project. Making it crucial to create project milestones and deadlines to keep the project on track. To ensure the project was pushing forward the project period was divided into phases with several milestones. The problem with the planning was the team had underestimated the workload for a two person team. Ending up in deadlines being pushed. The general planning and structure for this project could have been better. In retrospect, it would make sense to make a master plan again but be much better to time log every task to ensure the deadlines are meet. Another problem has been to delimitate the scope of the project and keep focusing on the most crucial parts.

It has been a challenging project working in a new team with half the workforce as there normally has been throughout the studies. Furthermore, it has been challenging to have a more opportunity based approach opposite to the problem-based approach which has been taught through the last four and a half years. At the same time, it has been a great learning experience to have made a project where both team members have been out of their comfort zone and gained new skills within the field of design.

List of References

1. BBC. Photosynthesis. [bbc.co.uk Web site. http://www.bbc.co.uk/schools/gcsebitesize/science/add_aqa_pre_2011/plants/plants1.shtml](http://www.bbc.co.uk/schools/gcsebitesize/science/add_aqa_pre_2011/plants/plants1.shtml). Updated 2011. Accessed 02.02.2017.
2. Seah Dave. Storytelling by design davidseah.com Web site. (<http://davidseah.com/category/inspiration/>). Updated 2006. Accessed 02.02.2012.
3. Verganti R. 2003 Design as brokering of languages: Innovation strategies in italian firms. *Design Management Journal* page 34-42. doi: 10.1111/j.1948-7169.2003.tb00050.x.
4. Jensen Bjarne, Johansen Jens, Karbæk Kjeld, Rasmussen Allan, Rasmussen Tomy. *Plast teknologi. Erhversskolernes Forlag; 2000.*
5. Lefteri Chris. 2015 *Makeing it manufacturing techniques for product design* 2nd Edition ed. London United Kingdom: Laurence King Publishing
6. Pedersen Borris, Rasmussen Mogens. 1999 *Materialelære for metalindustiren.* 4.Edition ed. Erhversskolernes Forlag
7. Ostrynski N. *Pressede Børnefamilier vil selv.* . October 17 2015. Available from: <https://www.b.dk/nationalt/pressede-boernefamilier-vil-selv>. Accessed 02.02.2017.
8. Lassen HA, Cankaya A, Bolvig Poulsen S, Wandahl S, Sørensen H. 2010 *InnoDoors slutbrugerens værdier.* 1.Edition ed. Aalborg Universitet: Projekt InnoDoors ved Center for Industriel Produktion
9. Stickdorn M, Schneider J. 2011 *This is service design thinking.* Hoboken, NJ: Wiley
10. Laursen L.N Tollestrup C. 2014 *Taxonomy for design thinking: Providing clarity*
11. Whitebread D, Coltman P, Jameson H, Lander R. 2009 *What exactly are children learning when they learn through play? Educational & Child Psychology;* page 40-52.
12. Huotari K, Hamari J. 2012 *Defining gamification - A service marketing perspective.*
13. Tjalve E. 1976 *Systematisk udformning af industriprodukter.* Akademisk Forlag
14. LED: The new fast-track to growth: Recipe development and practical applications in horticulture - part 1: Global examples LED recipes and development. ; 2016.
15. Mikkelsen N. 2016 *Urban farming- en trend slår rødder.*
16. Despommier D. 2011 *The vertical farm.*
17. Jakobsen 2016 PE. *Trends der findes mange typer af tendenser - fører læserne fra forvirring til overblik.*
18. Garden Media Group. *GTR garden trend report grow 365.* GTR Group. 2016
19. Growponics *Hydroponic greenhouse factories* <http://www.growponics.co.uk/> Web site. <http://www.growponics.co.uk/>. Updated 2016. Accessed 09.02.2017.
20. Cuffari Benedette 2017 *What is hydroponics?* www.azocleantech.com Web site. <http://www.azocleantech.com/article.aspx?ArticleID=586>. Updated 2016. Accessed 23.02.2017.
21. Envision. 2017 *Den digitale børnefamilie* envision.dk Web site. <http://digifamilie.envision.dk/indledning/>. Accessed 03.02.2017.
22. Osterwalder A. 2010 *Business model generation A handbook for visionaries, game changers, and challengers.* First ed. US: John Wiley & Sons Inc
23. Osterwalder A, 2015 *Value proposition design.* Frankfurt am Main Campus-Verl
24. Lerdahl E. 2001 *Staging for creative collaboration in design teams.* Fakultet for ingeniørvitenskap og teknologi.
25. Phillips PL. 2012 *Creating the perfect design brief : How to manage design for strategic advantage.* New York: Allworth Press

List of illustrations

ill.0: <https://goo.gl/czpyF9>
ill.1: <https://goo.gl/msytB5>
ill.2: Own illustration
ill.3: <https://goo.gl/bofrNe>
ill.3: <https://goo.gl/bWzi4w>
ill.4: <https://goo.gl/YzgpHl>
ill.4: <https://goo.gl/1PA71d>
ill.5: <https://goo.gl/OMs8S1>
ill.6: <https://goo.gl/vxm5e3>
ill.7: <https://goo.gl/Oerwhq>
ill.7: <https://goo.gl/g6twCD>
ill.7: <https://goo.gl/rdisTU>
ill.7: <https://goo.gl/aDGyOJ>
ill.8: <https://goo.gl/WrNBEu>
ill.8: <https://goo.gl/OvQdQO>
ill.8: <https://goo.gl/sylAfK>
ill.8: <https://goo.gl/IDPuld>
ill.9: <https://goo.gl/EQXrjO>
ill.9: <https://goo.gl/i3CVNo>
ill.10: <https://goo.gl/dhIXHB>
ill.10: <https://goo.gl/oYhZPd>
ill.10: <https://goo.gl/BhmPLD>
ill.11: Own illustration
ill.12: Own illustration
ill.13: <https://goo.gl/DpeqZZ>
ill.14: <https://goo.gl/cKlmcV>
ill.15: <https://goo.gl/MFTma4>
ill.15: <https://goo.gl/Bt3jB7>
ill.16: <https://goo.gl/huKlr3>
ill.16: <https://goo.gl/1i6qVh>
ill.16: <https://goo.gl/TZIDEC>
ill.16: <https://goo.gl/AOK6Le>
ill.16: <https://goo.gl/UI2Anh>
ill.16: <https://goo.gl/FWUGQT>
ill.16: <https://goo.gl/hbVt2z>
ill.16: <https://goo.gl/t3UsJe>
ill.17: <https://goo.gl/7pyln2>
ill.18: <https://goo.gl/Tb8hZX>
ill.20: <https://goo.gl/2On1eZ>
ill.21: <https://goo.gl/jmUaaa>
ill.22: Own illustration
ill.23: Own illustration
ill.24: <https://goo.gl/yTx1J5>
ill.24: <https://goo.gl/RyBdc8>
ill.24: <https://goo.gl/4wJyc1>
ill.24: <https://goo.gl/QHCc5y>
ill.25: Own illustration
ill.26: Own illustration
ill.27: Own illustration
ill.28: <https://goo.gl/tDi5Nu>
ill.28: <https://goo.gl/ZaeAqo>
ill.28: <https://goo.gl/MgwfUE>
ill.28: <https://goo.gl/MHmNZ1>
ill.28: <https://goo.gl/Kmk9mF>
ill.29: <https://goo.gl/Z8CZUE>
ill.29: <https://goo.gl/1f1d4M>
ill.30: Own illustration
ill.31: <https://goo.gl/7QFAe7>
ill.31: <https://goo.gl/JqNuYD>
ill.31: <https://goo.gl/dLbHTX>
ill.32: <https://goo.gl/tsKogc>
ill.32: <https://goo.gl/jyFrAZ>
ill.32: <https://goo.gl/zvRkmd>
ill.33-66: Own illustration
ill.67: <https://goo.gl/Kcs45q>
ill.67: <https://goo.gl/XbMjwp>
ill.67: <https://goo.gl/Lvg5c7>
ill.67: <https://goo.gl/pJq5LW>
ill.67: <https://goo.gl/R8XmPh>
ill.67: <https://goo.gl/cTN8ki>
ill.67: <https://goo.gl/zMgqg5>
ill.68: <https://goo.gl/EYrqmr>
ill.68: <https://goo.gl/tNhJfE>
ill.68: <https://goo.gl/JUwyV>
ill.68: <https://goo.gl/me2igL>
ill.68: <https://goo.gl/Xq1Sfs>
ill.68: <https://goo.gl/04NhXt>
ill.68: <https://goo.gl/YwDppy>
ill.68: <https://goo.gl/i5WwVR>
ill.68: <https://goo.gl/8YeXR7>
ill.68: <https://goo.gl/h6w1RC>
ill.68: <https://goo.gl/Vf4x5W>
ill.68: <https://goo.gl/2TYpQE>
ill.68: <https://goo.gl/VOEnL>
ill.68: <https://goo.gl/LxkxIW>
ill.68: <https://goo.gl/fqfWyc>
ill.69: <https://goo.gl/7ZKRR>
ill.70: <https://goo.gl/PjYHhN>
ill.71: <https://goo.gl/72MOPR>
ill.71: <https://goo.gl/iXR1tD>
ill.71: <https://goo.gl/TtdqKO>
ill.71: <https://goo.gl/vC5heu>
ill.71: <https://goo.gl/9pScXo>
ill.71: <https://goo.gl/hZn03u>
ill.71: <https://goo.gl/vg91YK>
ill.71: <https://goo.gl/6BQ8qw>
ill.71: <https://goo.gl/TeFQJN>
ill.71: <https://goo.gl/uM5Sge>
ill.72: <https://goo.gl/17FXUx>
ill.73-94: Own illustration

Worksheets

WS: 1 - Spiderweb
WS: 2 - Plantui's current Competitors
WS: 3 - Plantui SWOT
WS: 4 - Plantui Business Model Canvas
WS: 5 - Peoples comments: hydroponic growing
WS: 6 - Trend identification and description
WS: 7 - Grindsted Privat Skole
WS: 8 - Dansk Supermarked - Martin Rosenlund
WS: 9 - Potential Target Audience
WS: 10 - Envision study Insights and reflection
WS: 11 - Problems and opportunities
WS: 12 - Questionnaire
WS: 13 - Questionnaire follow up
WS: 15 - Interview: Leos Legeland
WS: 16 - Core paradox
WS: 17 - Hydroponics and cultivation
WS: 18 - Interview with Elisa Plantui
WS: 19 - Interview with CTO Kari Plantui
WS: 20 - Vision based approach to design
WS: 22 - P. Jordan - Four pleasures
WS: 22 - Mock-up round 1
WS: 23 - Storytelling and act it out
WS: 24 - User feedback on mock-ups - Lasse
WS: 25 - User feedback on mock-ups - Silas
WS: 26 - Contact to school and Workshop
WS: 27 - Mock-ups round 2
WS: 28 - Workshop at school
WS: 29 - Parameter for concept variations
WS: 30 - Developing two concept variations
WS: 31 - Value sliders
WS: 32 - Mock ups for testing
WS: 33 - Concept evaluation - Regine
WS: 34 - Concept evaluation - Line
WS: 35 - Concept evaluation - Susanne
WS: 37 - Inside concept outside of concept
WS: 38 - Growth medium
WS: 39 - Height adjustment
WS: 40 - Light
WS: 41 - Size and dimension
WS: 42 - Watering system
WS: 43 - Water pump Tjalve
WS: 44 - Form iteration 1 problem break down
WS: 45 - Plantui feedback
WS: 46 - Project cost and investment
WS: 47 - PCB control and light - Disassembly
WS: 48 - Developing the pump
WS: 49 - Testing growth conditions
WS: 50 - Plant Growth system
WS: 51 - Dimensioning of the reservoir
WS: 52 - Waterin indicator
WS: 53 - Making a jungle
WS: 54 - Plantui mold prices
WS: 55 - Production and material costs

sprout

