



**AALBORG UNIVERSITY**  
DENMARK

**Aalborg Universitet**

## **Assessment of electricity distribution grid control utilizing information access over non-ideal communication networks**

Kristensen, Thomas le Fevre

*DOI (link to publication from Publisher):*  
[10.5278/vbn.phd.tech.00027](https://doi.org/10.5278/vbn.phd.tech.00027)

*Publication date:*  
2017

*Document Version*  
Publisher's PDF, also known as Version of record

[Link to publication from Aalborg University](#)

*Citation for published version (APA):*  
Kristensen, T. L. F. (2017). *Assessment of electricity distribution grid control utilizing information access over non-ideal communication networks*. Aalborg Universitetsforlag. <https://doi.org/10.5278/vbn.phd.tech.00027>

### **General rights**

Copyright and moral rights for the publications made accessible in the public portal are retained by the authors and/or other copyright owners and it is a condition of accessing publications that users recognise and abide by the legal requirements associated with these rights.

- Users may download and print one copy of any publication from the public portal for the purpose of private study or research.
- You may not further distribute the material or use it for any profit-making activity or commercial gain
- You may freely distribute the URL identifying the publication in the public portal -

### **Take down policy**

If you believe that this document breaches copyright please contact us at [vbn@aub.aau.dk](mailto:vbn@aub.aau.dk) providing details, and we will remove access to the work immediately and investigate your claim.



**ASSESSMENT OF ELECTRICITY  
DISTRIBUTION GRID CONTROL UTILIZING  
INFORMATION ACCESSOVER NON-IDEAL  
COMMUNICATION NETWORKS**

**BY  
THOMAS LE FEVRE KRISTENSEN**

DISSERTATION SUBMITTED 2017



**AALBORG UNIVERSITY**  
DENMARK



---

---

**Assessment of electricity  
distribution grid control  
utilizing information access  
over non-ideal  
communication networks**

---

---

Ph.D. Dissertation  
Thomas le Fevre Kristensen

Dissertation submitted month 5, 2017

Dissertation submitted: May, 2017

PhD supervisors: Assoc. Prof. Rasmus Løvenstein Olsen  
Aalborg University  
Prof. Hans-Peter Schwefel  
Aalborg University

PhD committee: Associate Professor Tatiana K. Madsen (chairman)  
Aalborg University  
Network Arcitect, PhD Morten Tranberg Hansen  
Kamstrup A/S  
Senior Researcher Felicita Di Giandomenico  
Dependable Computing Lab at ISTI

PhD Series: Technical Faculty of IT and Design, Aalborg University

Department: Department of Electronic Systems

ISSN (online): 2446-1628  
ISBN (online): 978-87-7112-985-4

Published by:  
Aalborg University Press  
Skjernvej 4A, 2nd floor  
DK – 9220 Aalborg Ø  
Phone: +45 99407140  
aauf@forlag.aau.dk  
forlag.aau.dk

© Copyright: Thomas le Fevre Kristensen

Printed in Denmark by Rosendahls, 2017

# Abstract

Among private households the popularity of photo voltaic panels and small wind turbines is increasing. This introduction of power production into the distribution grids cannot be accommodated by the current power grid control systems. In order to ensure proper power quality, future distribution grid controllers will require up-to-date information about the power grid and its state. Since this information is distributed over the entire power grid, a communication network is needed to provide it to the controllers. In this dissertation we focus on how these communication networks and their imperfections impact the performance of the smart grid control system, and how the impact can be minimized.

To investigate this impact, several evaluation frameworks were developed, ranging from simulation frameworks to real-time experimental test setups. These frameworks were used to evaluate distribution grid energy balancing and voltage control use cases under different communication network scenarios.

Once the impact of imperfect communication network conditions on smart grid system performance is established, an information quality metric is proposed as a way to link communication network performance to overall control system performance as not to remove the need to evaluate the overall system performance for communication network analysis. Such an information quality metric is introduced as the probability of having incorrect information at the moment of control actuation due to communication network delay. This metric is then evaluated against the overall system performance to gain an understanding of how this metric can be used as an intermediate link between communication network studies and control studies.





# Resumé

Populariteten af solceller og hustandsvindmøller i private hjem er stigende. Denne introduktion af strømproduktion i distributionselnettet er ikke mulig i større grad med de nuværende elnetskontrol løsninger. For at sikre strøm-kvaliteten under denne øget produktion fra private, kræver fremtidige elnet-skotrollerer updateret information om elnettets tilstand. Da denne infor-mation er fordelt ud over hele elnettet, skal denne sendes over et kommu-nikationsnetværk til disse kontrollerer. I denne afhandling fokuseres der på, hvordan disse kommunikationsnetværk og deres fejl påvirker et fremtidigt elnets ydelse, samt hvordan denne påvirkning kan mindskes.

For at undersøge denne påvirkning er flere evalueringstværktøjer udviklet, fra simuleringsværktøjer til reel implementation i testeopstillinger. Disse evalueringstværktøjer er brugt til at evaluere energibalanceringskontrol samt spændingskontrol i fremtidens elnet under forskellige kommunikationssce-narier. Når disse kommunikationsscenariers påvirkning af elnettets ydeevne er fastlagt, introduceres en enhed for informationskvalitet, hvis formål det er at fungere som et bindeled imellem kvaliteten af kommunikationsnetvær-ke og den samlede elnets ydeevne.

Denne informationskvalitetsenhed er introduceret som sandsynligheden for at have forkert information i det øjeblik kontrolleren udfører sin kontrol grundet kommunikationsforsinkelser. Informationskvalitetsenheden bliver sammenholdt med den overordnede systemydeevne for bedre at forstå, hvor-dan den kan blive brugt som bindeled mellem kommunikationsnetværksstudier og kontrolstudier.



# Contents

<b>Abstract</b>	<b>iii</b>
<b>Resumé</b>	<b>v</b>
<b>Preface</b>	<b>xiii</b>
<b>Acknowledgemnets</b>	<b>xv</b>
<b>I Introduction</b>	<b>1</b>
<b>1 Introduction</b>	<b>3</b>
1 Smart Energy Distribution Grids . . . . .	3
2 Problem Statement . . . . .	5
3 Contribution to Collaborative Projects . . . . .	6
4 Dissertation Overview . . . . .	6
References . . . . .	7
<b>2 Problem Background</b>	<b>9</b>
1 Smart Grid Communication Technologies . . . . .	9
2 Information Quality Metrics . . . . .	10
3 Networked Control Systems . . . . .	10
3.1 Networked Energy Balancing Systems . . . . .	11
3.2 Networked Distribution Grid Voltage Control Systems .	12
4 Evaluation methodologies . . . . .	12
References . . . . .	13
<b>3 Evaluation Methodologies</b>	<b>17</b>
1 Simulation Frameworks . . . . .	17
2 Experimental Set-up . . . . .	19
3 Summary and Conclusions . . . . .	21
References . . . . .	22

<b>4</b>	<b>Communication Networks in Smart Grids Energy Balancing Controllers</b>	<b>23</b>
1	Communication in Smart Grid Energy Balancing . . . . .	23
2	Communication network based controller adaptation . . . . .	25
3	Summary and Conclusions . . . . .	27
	References . . . . .	27
<b>5</b>	<b>Information Quality Estimation for Event-driven Controllers</b>	<b>29</b>
1	Mismatch Probability in Event Driven Control Systems . . . . .	29
	1.1 Modelling Information Age . . . . .	30
	1.2 Modelling Information Dynamics . . . . .	33
2	Simulation Verification . . . . .	35
3	Summary and Conclusions . . . . .	37
	References . . . . .	39
<b>6</b>	<b>Mismatch Probability in Voltage Control</b>	<b>41</b>
1	Voltage Control Scenario . . . . .	41
2	Control performance Optimization with Multiple Assets . . . . .	42
3	Event Driven mmPr Impact on Control Performance . . . . .	44
4	Summary and Conclusions . . . . .	46
	References . . . . .	46
<b>7</b>	<b>Conclusion and Outlook</b>	<b>47</b>
<b>II</b>	<b>Papers</b>	<b>49</b>
<b>A</b>	<b>Utilizing Network QoS for Dependability of Adaptive Smart Grid Control</b>	<b>51</b>
1	Introduction . . . . .	52
2	State of the art . . . . .	54
3	System architecture and use case . . . . .	54
	3.1 System architecture and assumptions . . . . .	55
	3.2 Adaptive communication network functionality . . . . .	56
4	Example Smart Grid Control Scenario . . . . .	56
	4.1 Regulation of thermostatic loads . . . . .	57
	4.2 Communication network . . . . .	60
	4.3 QoS-based Adaptive Control . . . . .	61
5	Simulation methodology . . . . .	63
6	Evaluation of the network aware control system . . . . .	64
	6.1 Performance metric definition . . . . .	64
	6.2 Base scenario . . . . .	65
	6.3 Evaluation of the communication network influence and proposed solution . . . . .	66

## Contents

7	Conclusion and future work . . . . .	67
	References . . . . .	68
<b>B</b>	<b>Smart Grid Control and Communication: the SmartC2net Real-Time HIL Approach</b>	<b>71</b>
1	Introduction . . . . .	72
2	Use Cases . . . . .	74
3	Control Architecture . . . . .	75
3.1	Hierarchical Control Structure . . . . .	75
3.2	Control Functionalities and Requirements . . . . .	76
3.3	Controllers . . . . .	76
4	Real-Time HIL Setup . . . . .	78
5	Experimental Results . . . . .	81
5.1	Distribution Grid . . . . .	81
5.2	Simulation Results . . . . .	81
5.3	Discussion of Simulation Results . . . . .	84
	References . . . . .	86
<b>C</b>	<b>On-line Configuration of Network Emulator for Intelligent Energy System Testbed Applications</b>	<b>87</b>
1	Introduction . . . . .	88
2	Related Works . . . . .	89
3	Smart Energy Systems Laboratory . . . . .	89
3.1	Communication Layer . . . . .	89
3.2	Control Layers . . . . .	91
3.3	Power System Assets . . . . .	91
3.4	Online Configuration of Network Emulator Overview . . . . .	92
4	System Model . . . . .	92
4.1	Visualization Interface . . . . .	93
4.2	Kaunet Configuration . . . . .	94
4.3	Network Sockets . . . . .	95
4.4	Network Emulation Configuration . . . . .	96
5	Conclusion . . . . .	96
	References . . . . .	97
<b>D</b>	<b>Analysis of Information Quality in event triggered Smart Grid Control</b>	<b>99</b>
1	Abstract . . . . .	100
2	Introduction . . . . .	100
3	Scenario description . . . . .	101
4	Mismatch probability modelling . . . . .	104
4.1	Information modelling . . . . .	105
5	Analysis of parameter impact on mmPr . . . . .	106

6	Conclusion . . . . .	109
	References . . . . .	111
<b>E</b>	<b>Information-Quality based LV-Grid-Monitoring Framework and its Application to Power-Quality Control</b>	<b>113</b>
1	Introduction . . . . .	114
2	Related Work . . . . .	115
3	Power Quality Control Scenario . . . . .	115
	3.1 Voltage control approach . . . . .	116
	3.2 Baseline Data Access . . . . .	117
	3.3 Network modelling . . . . .	119
4	Adaptive Monitoring Framework . . . . .	119
	4.1 Adaptivity Concept . . . . .	119
	4.2 Task Management Approach . . . . .	120
	4.3 Information Quality Estimation . . . . .	122
5	Simulation Framework and Evaluation Results . . . . .	124
6	Conclusion and Future Work . . . . .	126
	References . . . . .	127
<b>F</b>	<b>Distribution Grid Energy Balancing over Heterogeneous Communication Networks</b>	<b>129</b>
1	Introduction . . . . .	130
2	Energy Balancing in Medium and Low voltage grids . . . . .	132
3	Control architecture . . . . .	134
4	Evaluation Methodology and Evaluation Scenario . . . . .	136
5	Evaluation Results . . . . .	139
	5.1 MV grid reference tracking . . . . .	139
	5.2 Testbed analysis of LV tracking capability . . . . .	140
	5.3 Sensitivity to high communication delays and losses . . . . .	141
6	Conclusion and Outlook . . . . .	143
	References . . . . .	145
<b>G</b>	<b>Information Access for Event-Driven Smart Grid Controllers</b>	<b>151</b>
1	Introduction and background . . . . .	152
2	System Architecture and Case Study . . . . .	154
	2.1 System Architecture . . . . .	154
	2.2 Generalized event-driven controller . . . . .	156
	2.3 Evaluation scenario and default parameters . . . . .	156
	2.4 Reference grid behaviour without voltage control . . . . .	157
3	Information access schemes and their evaluation . . . . .	158
	3.1 Information access schemes . . . . .	158
	3.2 Information quality metrics and their calculation . . . . .	161
	3.3 Application to LV grid scenario . . . . .	164

## Contents

4	Voltage Control with ideal information access . . . . .	167
4.1	Controller implementation . . . . .	168
4.2	Simulation Results . . . . .	168
5	Simulation analysis of controlled system with non-ideal information access . . . . .	170
5.1	Impact of communication delays on reactive strategy . .	170
5.2	Impact of communication delays and update rate on periodic strategy . . . . .	173
6	Conclusion and future work . . . . .	177
7	Acknowledgement . . . . .	179
	References . . . . .	180

## Contents



# Preface

This dissertation is in the format of a collection of papers in partial fulfillment of a Ph.D. study at the Wireless Communication Networks section, Department of Electronic systems at Aalborg University, Denmark. The Ph.D. study was done from July 2013 to May 2017 under the supervision of Associate Professor Rasums Løvenstein Olsen and Professor Hans-Peter Schwefel and was supported by the European Community's Seventh Framework Programme (FP7/2007-2013) under grant agreement n<sup>o</sup> 318023 for the SmartC<sup>2</sup>Net project.

This dissertation is written in two parts, the first part consists of chapters 1-7 giving the background, motivation, and an overview of the dissertation contributions as well as making concluding remarks. The second part includes the details of the contributions in the form of seven published papers. The attached papers have been reformatted to fit the format of this dissertation, but is otherwise left unedited since publication. For this reason, notation may vary from paper to paper.

Thomas le Fevre Kristensen  
Aalborg University, May 31, 2017

## Preface

# Acknowledgements

This dissertation was made possible not only by my own efforts, but also by the numerous people supporting me throughout the past four years. Most importantly, my supervisors Rasmus Løvenstein Olsen and Hans-Peter Schwefel who have done a wonderful job of guiding me and ensuring the quality of my work.

In addition to my supervisors, I would like to show my gratitude to my colleagues at the Wireless Communication Networks section for making my stay at Aalborg University enjoyable. Especially I would like to extend great gratitude to my office mates Jacob Theilgaard Madsen and Lars Møller Mikkelsen for the great times we have had through the many years we have now known each other.

All members of the SmartC<sup>2</sup>Net research project also deserve my appreciation for helping lift my work to heights impossible to achieve alone. Especially, I would like to thank my close colleagues with who I developed the experimental test setup at Aalborg University, most notably Florin Iov who coordinated the work and lead the test setup to be an enormous success.

Lastly I would like to thank my family and friends who have supported me through the years. Particularly, my wife Helene le Fevre Kristensen has shown great love and support, even when I was working late nights or weekends. I would like to thank her for taking fantastic care of our son Christian when my studies kept me from home.

Thomas le Fevre Kristensen  
Aalborg University, May 31, 2017

## Acknowledgements

## **Part I**

# **Introduction**



# Chapter 1

## Introduction

This dissertation deals with communication challenges arising in the attempt to incorporate renewable energy sources into the power grid. Specifically, it deals with the communication challenges in distributed control in low voltage (LV) distribution grids. The concept of smart grids is introduced in the following section. This introduction focuses on the smart grid issues addressed in this dissertation, though many additional issues could be considered in smart grid development.

### 1 Smart Energy Distribution Grids

The classical power grid is split into two parts; transmission grid and distribution grid. Transmission grids are used to transmit power over long distances from large power plants to different regions. The distribution grid distributes the power from the transmission grid to the consumers. With the addition of renewable energy sources, energy production has moved away from the large power plants and into distribution grids, and in recent years moved all the way to the LV distribution grids in the form of Photo Voltaic (PV) panels, windturbines, etc. at a household level. This change in grid structure causes new challenges to ensure proper grid stability. Without production in the LV distribution grid, the transformer (controlled by the secondary substation controller) can, based on the amount of power it is putting into the grid, estimate the power quality in the entire LV distribution grid and thereby determine how much power to inject into the grid. This is possible because the voltage will always be lower further away from the transformer given that the system operates as originally designed. When adding production into LV distribution grids, voltage values can no longer be accurately estimated by only knowing the amount of power the substation injects into the grid, because voltages rises at the points energy sources are connected,

when they are producing. Since the production of these producers depends on outside influences (e.g. the weather), they cannot simply be included in the voltage estimation model. Therefore, controllers must collect measurements from around the grid to determine set-points, which results in proper power quality. This kind of controller ensures that the power at the consumer has the correct voltage within the grid codes.

The power grid also faces additional problems with the introduction of renewable energy sources. These energy sources tend to be based on the weather (PV panels, windturbines, etc.), which means power cannot be produced when needed, but only when the weather permits it. This introduces the need for energy balancing controllers, which is a controller balancing the power produced with the power consumed. This balancing would preferably be achieved through flexible consumers. A flexible consumer could for example be a refrigerator where additional power can be consumed by lowering the temperature in the refrigerator, and less power can be consumed by allowing higher temperatures before the refrigerator starts cooling again, as explored in [A]. This control approach is preferred because balancing using producers means if too much power is produced, a renewable energy source must be turned off effectively wasting the energy it could have produced. If not enough energy is produced, weather based energy sources cannot be turned up, and the additional production must be covered by other energy sources, possibly using fossil fuels. Entities offering actuation possibilities to a controller like controllable consumers/producers will collectively be referred to as *controllable assets* in this dissertation. For the controller to determine which assets should change behavior, the controller must collect information from all assets about their state to determine which assets are capable of resolving the issue.

The collection of information in the smart grid requires communication infrastructure not currently present in most distribution grids. This dissertation investigates the feasibility of using existing 3rd party communication infrastructure to support LV grid control. An overview of this approach is shown in Figure 1.1.

When a controller depends on information distributed throughout the smart grid, information outdated by communication network delays will impact the overall system performance. How imperfect communication network conditions effects control system performance will be addressed in this dissertation. However, if the quality of the information used for control actuation can be determined, this could be used as an *intermediate link* to determine proper network configuration without having to evaluate the entire control system. Firstly though, the term *information quality* has to be defined before its usefulness as such an *intermediate link* between communication networks and control system performance can be determined. This will be discussed in further details later in Chapter 5.



## 2. Problem Statement

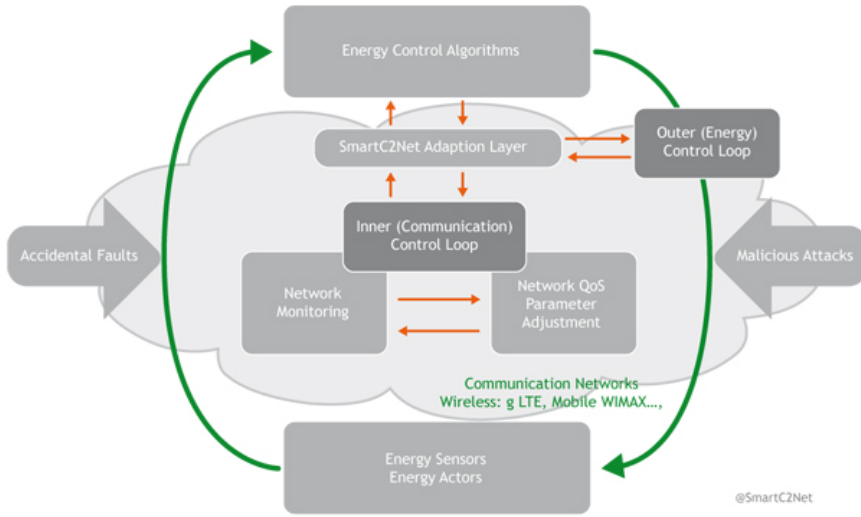

Fig. 1.1: Smart Grid system architecture [1].

## 2 Problem Statement

Reliable control of the smart grid is a vital part of the future power grid. If a controller does not maintain proper power quality, it could disrupt the supply of power. In today's power grid, the power grid control relies on local measurements, and this problem, therefore, has no communication network challenges. In the smart grid, the control is based on measurements from distributed information sources. Furthermore, the control of distributed flexible power consumers is part of the smart grid. Ensuring reliable control in the smart grid is, therefore, not only a control problem, but also a communication network problem.

In today's power grid, a communication link between controllers and controllable assets is not established. Therefore, a communication infrastructure must be implemented before the smart grid can be realized. Implementing a new reliable high speed connection, like fiber optics, to all consumers in the power grid would be very expensive, and is not feasible. Reusing an existing communication infrastructure, which must be shared with the current users, can result in poor communication network performance.

**It is hypothesized that poor network performance causes grid control performance degradation, and that using information quality metrics can be beneficial as an intermediate link between communication network Quality of Service metrics and control performance.**

This problem statement leads to several questions used to guide the stud-

ies performed in this dissertation:

1. **How can smart grid functionalities be evaluated under imperfect network conditions?**
2. **What impact do imperfect communication networks have on smart grid control performance?**
3. **How can information quality metrics be modelled in smart grid scenarios?**
4. **Can information quality metrics be a useful link between smart grid control performance and communication network conditions?**

### **3 Contribution to Collaborative Projects**

This research in this dissertation was conducted as part of the SmartC<sup>2</sup>Net project [1]. SmartC<sup>2</sup>Net was a European research project with a consortium consisting of two universities, two research partners, and three industrial partners. The goal of the project was to investigate the feasibility and development of smart control of energy distribution grids over heterogeneous communication networks. This was done as a wide interdisciplinary study combining the fields of control and automation, energy technologies, and communication networks. The project aimed to construct several experimental set-ups, and use these to test four different use cases: Automated meter reading and customer energy management systems, Electrical Vehicle charging in low voltage grids, External generation site, and Voltage control in medium voltage grids [2]. This dissertation contributed to the development of the experimental set-up at Aalborg University, and the external generation site use case. This dissertation looks into the complete development and implementation of the communication network infrastructure of the DCDG test bed. Contributions was also made to the assesment of the impact of imperfect communication networks on grid control performance, as well as how to lessen this impact from a communication network aspect.

### **4 Dissertation Overview**

This dissertation looks into the impact of imperfect communication networks by conducting both simulations and experimental tests using frameworks described in chapter 3 based on Papers [B] and [C]. The impact of imperfect communication network conditions on energy balancing controllers is discussed in chapter 4. Energy balancing control is evaluated using the developed evaluation frameworks based on Papers [A] and [F] and determines

how communication networks impact smart grid functionalities. In chapter 5, an information quality metric is developed. This metric models network performance as well as information dynamics mathematically based on Paper [D]. The validity of this information quality metric is verified in Paper [G] by relating it to a voltage control use case as outlined in chapter 6. Finally, chapter 7 draws conclusions from the dissertation and discusses future research opportunities.

## References

- [1] S. Consortium, "Fp7 smart control of energy distribution grids over heterogeneous communication networks project," 2013, <http://smartc2net.eu/>.
- [2] —, "Smartc2net deliverable d1.1: Smartc2net use cases, preliminary architecture and business drivers," 2013, <http://smartc2net.eu/>.

## References

# Chapter 2

## Problem Background

This chapter will present and discuss the relevant background for the dissertation. This is split into three sections. First, the smart grid communication technologies section discusses communication technologies relevant for the scenarios considered in this dissertation. This will also detail how communication technologies are modeled. The information quality metrics section details the background for the choice of information quality metric, and the evaluation methodologies section discusses different approaches to evaluating smart grid functionalities. Finally, the networked control systems section details the background for the work on the inter-operability of control systems and communication networks. This last section is further split into the two main control systems considered in this dissertation; energy balancing and voltage control.

### 1 Smart Grid Communication Technologies

The article, [10] provides an overview of the different technologies available for smart grid communication, and lists the relevant standards, from these it was intended to model several, and evaluate the different control scenarios under each modeled technology. In the SmartC<sup>2</sup>Net project, several communication technologies were implemented and tested to obtain measurement data on the performance of each technology [7]. In this dissertation, we limit the the scope to a single communication network technology, and instead focus on parametric studies of communication network parameters to gain a broader understanding of the impact of the communication network. Power line communication(PLC) was chosen as this technology since its infrastructure follows the power lines the smart grid aims to control and because the infrastructure would be owned by the power company using it. These traits make the technology an attractive choice for smart grid communication, but

the technology also provides very poor performance, which makes it an interesting study case when considering the impact of communication networks on control performance.

The viability of using PLC is investigated in [1] through simulation. Two different topologies for the smart grid communication are proposed and then simulated. The paper sets requirements that the communication should adhere to, and investigates their capability to meet these requirements using PLC. The results show that PLC can fulfill the stated requirements in only a limited set of scenarios, and hence more relaxed communication requirements need to be deployed, or a different communication solution must be used. This shows that communication network performance can cause problems for system performance, if not taken into account.

## 2 Information Quality Metrics

Information quality can be defined in many different ways, [3] defines it as the probability of an information consumer having incorrect information from an information source at the specific time of information consumption. [3] denotes this metric, Mismatch Probability (mmPr), and defines it for three different information access strategies; Reactive, Proactive Periodical, and Proactive Event driven. The paper considers information of discrete states and models it using Markov Models. Modeling information dynamics using Markov models simplifies the mathematics of the mmPr models significantly, therefore, this approach is continued through the mmPr models developed in chapter 5. This is done even though the information considered is continuous in nature, making fitting it to a Markov model non-trivial as a discretization level has to be determined which cannot be so large that important information dynamics are lost, but also not so small that two neighbouring states represents an insignificant difference in control performance if mismatching.

In this dissertation, the mmPr models are developed further to fit event driven control scenarios similarly to how it is done for periodical update scenarios in [6]. mmPr in periodical control scenarios are also investigated in [16].

## 3 Networked Control Systems

Networked control systems are systems where a controller is connected to sensors and actuators through a communication network with significant impact on system performance. The significance of the communication network in a control system can have multiple causes like, very fast control actions

or a poorly performing communication network technology. For the distribution grid control scenarios considered here, the large physical distances between entities, and the high availability requirements of the power grid are the main reasons communication networks are considered when evaluating smart grid functionalities.

The networked control problem can be tackled from several angles: [11] investigates in numerous articles how heterogeneous networks can be taken into account when designing control systems. Similarly [22] shows how control loop intervals can be changed dynamically depending on communication network quality. Paper [A] develops a middleware solution for adapting control set-points to counter poor network performance. However, this solution is limited to a specific controller type. This dissertation focuses on two types of networked control systems; energy balancing and Voltage control.

#### 3.1 Networked Energy Balancing Systems

Energy balancing systems attempt to balance produced power with consumed power at any given time. The need for energy balancing controllers arises from the increasing part of power production coming from non-controllable sources like wind or the sun. These controllers are often operated fairly slowly compared to communication network delays, at control periods on the time scale of seconds to minutes. However, as shown in [6], there can be a significant gain in controller performance from using information obtained just before a new control cycle rather than utilizing the entire control period for communication updates.

Energy balancing has been investigated in simulation models in [8] [9]. These papers were also part of the SmartC<sup>2</sup>Net project, and, therefore, use the same control architecture and the same controllers as is used in this dissertation. However, here we evaluate the control system using the Hardware-In-the-Loop(HIL) testbed which provides a much finer granularity power grid model and also includes the communication protocol realizations in physical entities. Similarly, simulations studies were used to analyze the impact of imperfect communication on other control use-cases. [15] considers the scenario of a wind-farm controller, [19] simulates the usage of electric vehicles in a vehicle-to-grid scenario, and [2] investigate the impact of communication outages on Demand Management schemes. Many different controller designs has been studied e.g. in [5] and [13], however with the focus on controller design and therefore often assuming perfect network conditions.

### 3.2 Networked Distribution Grid Voltage Control Systems

Voltage controllers ensure the voltages are kept within the grid code specifications at all times. This is currently achieved measuring the voltage level at the secondary substation, and modeling the distribution grid under the assumption that the voltage decreases with the distance from the substation. With the secondary substation being the only power injection spot in the grid, this assumption holds true. However, when introducing household PV panels into the distribution grid, this is no longer the case. Further more, the power output of PV panels can change significantly in a matter of seconds if a cloud passes in front of the sun making the voltage fluctuate significantly more than current controllers are designed to handle. For this reason, smart grid voltage controllers cannot rely solely on measurements from the secondary substation, but must also include information from around the grid. Distribution grid voltage control is, therefore, transitioning into a networked control system.

Most control strategies are based on periodical control [20] since the goal of controllers often is to follow some provided reference. However, in the case of voltage control, the goal is to simply keep the voltages within specified grid codes [21]. This means that as long as the grid codes are fulfilled, the controller does not need to perform any control actions, and indeed should not since utilizing asset flexibility comes at some cost. Event driven control has been investigated previously [23]. However, modelling mmPr on an event driven control scenario has not previously been attempted, and the event driven voltage control scenario provides a study case for such mmPr models developed in this dissertation.

## 4 Evaluation methodologies

Evaluating smart grid functionalities is a complex task. This complexity arises from the fact that smart grids are comprised of several different disciplines including: Economics, law, control, energy, and communication disciplines. Including several disciplines into a single evaluation framework makes these evaluation methodologies especially complex. [4] attempts to encompass all these disciplines into a single simulation framework based on the framework developed in [A]. Though this framework proved a strong tool for several studies [15], [17], [14].

An overview of several other simulation frameworks is given in [18], which also discusses the advantages and disadvantages of the HIL approach also used in this dissertation. In general having real power grid hardware included in the simulation increases the confidence of the produced results as compared to pure simulation studies. Having actual power grid components included does in most cases mean simulations have to run in real



time, whereas pure simulation studies can normally be performed significantly faster. For these reasons, both of these approaches will be used in this dissertation.

The next step after experimental laboratory tests is field testing. Though this can be done, and indeed it is [12], this is very expensive way to evaluate smart grid functionalities as it requires much more developed implementations. Additionally, the risks involved with these tests are significantly higher since failures would affect real households. For these reasons, this way of evaluation is not considered further in this dissertation.

## References

- [1] F. Aalamifar, H. Hassanein, and G. Takahara, "Viability of powerline communication for the smart grid," in *Communications (QBSC), 2012 26th Biennial Symposium on*, 2012, pp. 19–23.
- [2] S. Bessler, M. S. Kemal, N. Silva, R. Olsen, F. Iov, D. Drenjanac, and H. Schwefel, "Grid-aware demand management in electricity distribution grids," *Sustainable Energy, Grids and Networks*, 2017, under review.
- [3] M. Bøgsted, R. L. Olsen, and H.-P. Schwefel, "Probabilistic models for access strategies to dynamic information elements," *Performance Evaluation*, vol. 67, no. 1, pp. 43 – 60, 2010. [Online]. Available: <http://www.sciencedirect.com/science/article/pii/S0166531609001175>
- [4] E. Consortium, "Efficient distribution of green energy(edge)," 2015, <http://kom.aau.dk/project/edge/>.
- [5] S. J. Crocker and J. L. Mathieu, "Adaptive state estimation and control of thermostatic loads for real-time energy balancing," in *2016 American Control Conference (ACC)*, July 2016, pp. 3557–3563.
- [6] M. Findrik, J. Groenbaek, and R. L. Olsen, "Scheduling data access in smart grid networks utilizing context information," in *2014 IEEE International Conference on Smart Grid Communications (SmartGridComm)*, Nov 2014, pp. 302–307.
- [7] M. Findrik, "Network-aware adaptation framework and its applications to smart grid controllers," Ph.D. dissertation, 2016.
- [8] M. Findrik, R. Pedersen, E. Hasenleithner, C. Sloth, and H.-P. Schwefel, "Test-bed assessment of communication technologies for a power-balancing controller," in *Energy Conference (ENERGYCON), 2016 IEEE International*. United States: IEEE, 2016.
- [9] M. Findrik, R. Pedersen, C. Sloth, and H.-P. Schwefel, "Evaluation of communication network state estimators for adaptive power-balancing," in *5th D-A-CH+ Energy Informatics Conference 2016*, F. Kupzog and W. Elmenreich, Eds. Springer, 2017.
- [10] V. Gungor, D. Sahin, T. Kocak, S. Ergut, C. Buccella, C. Cecati, and G. Hancke, "Smart grid technologies: Communication technologies and standards," *Industrial Informatics, IEEE Transactions on*, vol. 7, no. 4, pp. 529–539, 2011.

## References

- [11] W. P. M. H. Heemels, A. R. Teel, N. van de Wouw, and D. Nešić, "Networked control systems with communication constraints: Tradeoffs between transmission intervals and delays," in *2009 European Control Conference (ECC)*, Aug 2009, pp. 4296–4301.
- [12] J. M. Jørgensen, S. H. Sørensen, K. Behnke, and P. B. Eriksen, "Ecogrid eu x2014; a prototype for european smart grids," in *2011 IEEE Power and Energy Society General Meeting*, July 2011, pp. 1–7.
- [13] A. Lucas and S. Chondrogiannis, "Smart grid energy storage controller for frequency regulation and peak shaving, using a vanadium redox flow battery," *International Journal of Electrical Power & Energy Systems*, vol. 80, pp. 26 – 36, 2016. [Online]. Available: <http://www.sciencedirect.com/science/article/pii/S0142061516000375>
- [14] J. T. Madsen, J. d. J. Barradas-Berglind, T. K. Madsen, and H. P. Schwefel, "On the impact of information access delays on remote control of a wind turbine," in *2015 IEEE Eindhoven PowerTech*, June 2015, pp. 1–6.
- [15] J. Madsen, M. Findrik, T. Madsen, and H.-P. Schwefel, "Optimizing data access for wind farm control over hierarchical communication networks," *International Journal of Distributed Sensor Networks*, vol. 12, no. 5, 2016.
- [16] J. Madsen, "On the impact of communication and information access on wind-farm control and demand management in smart grid scenarios," Ph.D. dissertation, 2016, PhD supervisor: Professor Hans-Peter Schwefel, Aalborg University, Denmark Assistant PhD supervisor: Associate Professor Tatiana Kozlova Madsen, Aalborg University, Denmark.
- [17] J. T. Madsen, M. Findrik, D. Drenjanac, and H.-P. Schwefel, *Investigating Wind Farm Control Over Different Communication Network Technologies*. Cham: Springer International Publishing, 2015, pp. 129–140. [Online]. Available: [http://dx.doi.org/10.1007/978-3-319-25876-8\\_11](http://dx.doi.org/10.1007/978-3-319-25876-8_11)
- [18] K. Mets, J. A. Ojea, and C. Develder, "Combining power and communication network simulation for cost-effective smart grid analysis," *IEEE Communications Surveys Tutorials*, vol. 16, no. 3, pp. 1771–1796, Third 2014.
- [19] H. S. V. S. K. Nunna, S. Battula, S. Doolla, and D. Srinivasan, "Energy management in smart distribution systems with vehicle-to-grid integrated microgrids," *IEEE Transactions on Smart Grid*, vol. PP, no. 99, pp. 1–1, 2017.
- [20] R. Pedersen, M. Findrik, C. Sloth, and H.-P. Schwefel, "Network condition based adaptive control and its application to power balancing in electrical grids," *Sustainable Energy, Grids and Networks*, 2017, submitted.
- [21] N. G. E. T. plc, *The grid code Issue 5*, 21st ed. National Grid Electricity Transmission plc, March 2017.
- [22] M. Pohjola, "Adaptive control speed based on network quality of service," in *Control and Automation, 2009. MED '09. 17th Mediterranean Conference on*, 2009, pp. 784–789.
- [23] J. H. Sandee, W. P. M. H. Heemels, and P. P. J. van den Bosch, "Event-driven control as an opportunity in the multidisciplinary development of embedded

## References

controllers," in *Proceedings of the 2005, American Control Conference, 2005.*, June 2005, pp. 1776–1781 vol. 3.

## References

# Chapter 3

## Evaluation Methodologies

This chapter aims to answer Question 1 from the problem statement in section 2 which asks: How can smart grid system performance be evaluated under imperfect network conditions? Ways of evaluating smart grid system performance are vital to determine how the smart grid is affected by imperfect communication network conditions. In this dissertation, several different evaluation methodologies were developed each with its own separate contribution to this dissertation. There are two main types of evaluation methodologies developed: simulation frameworks and experimental setup, each of which is described in the sections below. Both types are used in this dissertation as there is a trade-off between execution time and evaluation precision.

### 1 Simulation Frameworks

This section contributes to the development of three simulation frameworks. First an inter-disciplinary smart grid simulation framework developed in collaboration with the dissertation [9]. Second, contributions were made to incorporate communication network simulations into the DiSC simulation framework [11]. Lastly, a simulation framework was developed to validate and evaluate mathematical information quality models. The following section will introduce an experimental setup based on the HIL approach. [10] provides an overview of evaluation methodologies, and also details the accuracy advantages of the HIL approach as opposed to pure simulation tools.

An inter-disciplinary simulation framework was developed for Paper [A]. This framework had the strong advantage of linking a network simulation tool (OMNeT++) to a simulation tool commonly used for control simulations (MATLAB). This tool makes complex network simulations easier to implement than simply using MATLAB, while also making control simulations

more convenient as MATLAB is widely used for control system simulation studies. Joining the two simulation tools into a single framework caused complex timing issues due to the fact that both tools must agree on the current simulation time for simulations to run properly. Agreeing on simulation time is in this case not trivial since one simulator is event driven resulting in varying simulation time increments, whereas the other was periodical with fixed time increments. Furthermore, the flow of simulation time depends not on real-time, but on the computational power of the platform on which it is simulated. Since OMNeT++ is an event based simulation tool, simulating stochastic communication delays, it was assigned the task of keeping track of the simulation time. By making the simplifying assumption that controllers are periodical, and that assets only react when set-points are received from the controller, OMNeT++ was programmed to determine when MATLAB simulations were needed during simulation time, and would simply invoke MATLAB functionalities at these points in time essentially removing the periodical nature of the MATLAB simulator. This eliminated the need for MATLAB to be aware of timings, and only perform simulation tasks when invoked. The development of this tool has since [A] continued through the EDGE research project [2], where it made large contributions to [9]. Complete framework implementation details can be found in [8].

The DiSC simulation framework [11] was developed to simulate smart grid use cases similar to the ones considered in this dissertation, and included asset models for several power grid entities, as well as a model for power grid simulation. For this reason, this tool was used in several studies performed in this dissertation. The DiSC tool is a MATLAB based simulation tool designed to combine power grid and control simulations, and even provides simple communication network simulation capabilities. The fact that communication networks simulations were included meant that the simulator was already designed to be aware that information at a source may not be the same at the destination. This made implementation of more complex communication network simulations significantly easier. This dissertation provides this addition for the DiSC tool, allowing simulation studies which provided the basis for [E] as well as [G]. Communication networks were modelled using stochastic models assuming independent and identically distributed samples. Though this could be expanded to use more complex communication network models, the communication networks simulatable with this simulator will not be as complex as with the previous simulator where communication network simulations were done using a dedicated simulation tool. However, having communication network simulations integrated into the same software saves a lot of communication and synchronization overhead, allowing a significant reduction in execution time.

Chapter 5 deals with the mathematical development of information quality models. Simulation studies were conducted to validate these models.

## 2. Experimental Set-up

However, this validation of mathematical models requires significantly different simulations than simulating power grid functionalities. This sparked the development of a third framework implementing information quality models as well as information dynamics models. Information access strategies were implemented and used to determine empirical values for the information quality metric to be compared with the values predicted by the mathematical models.

## 2 Experimental Set-up

A large experimental set-up was developed for the purpose of testing smart grid functionalities. This test set-up was done as a collaboration between several people as is evident from Paper [B], where this dissertation contributes the development of the network communication network infrastructure needed for the test set-up. This experimental test set-up was developed to be able to gain higher confidence in produced results when compared to the simulation frameworks. This test setup is significantly closer to a real world smart grid implementation than what would be possible in a simulation framework, due to the increased simulation granularity of the grid simulation, and the fact that network communication were done using an actual network stack with actual protocol realizations. Figure 3.1 shows the conceptual setup of the experimental setup. The setup consists of four main parts: The Real-time Digital Simulator [12], the experimental electrical grid, the controllers, and the ICT layer. The Real-time Digital Simulator is a simulation platform

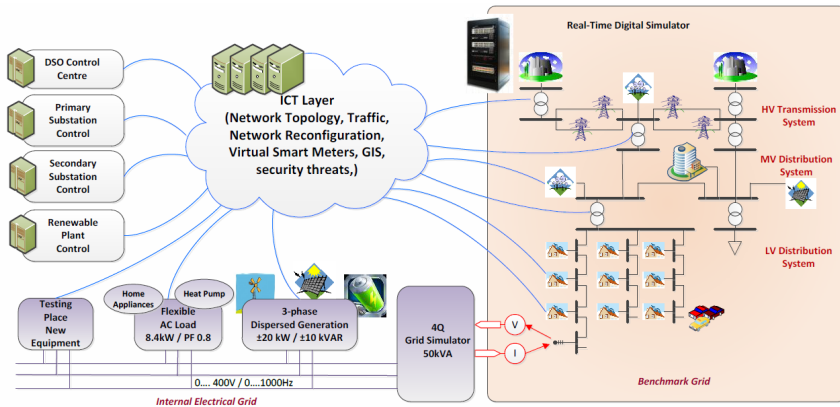

Fig. 3.1: Conceptual overview of the experimental test setup [4].

capable of simulating large power grids in real time. It is responsible for keeping track of the flow of power in the entire simulated power grid, as well as running the models for all consumers and producers in the power

grid. The internal electrical grid consists of real power grid components connected to a small power grid. The power in this grid is controlled based on set points from the Real-time Digital Simulator to emulate the experimental electrical grid as being part of the power grid simulated inside the simulator. Similarly, the power grid components can take set-points from controllers, and impose different loads on the experimental power grid giving inputs to the Real-time Digital Simulator. The controllers are software packages also developed in [3]. These packages are placed on individual PC's and are able to take measurements from the Real-time Digital Simulator, determine set-points, and distribute them to asset models inside the Real-time Digital Simulator. The ICT layer enables all the communication between the three other parts. Since the ICT layer were developed as part of this dissertation, additional details are provided here.

The center of the ICT layer is a single server controlling information flow in the experimental test setup. This network server is connected to a switch providing every component in the test setup a virtual network connecting them directly to the server. This setup means all communication network traffic in the test setup is routed through this server. This allows the server to apply traffic shapers, which enables the emulation of different communication network technologies through proper modelling. This modelling was done based on communication network quality of service measurements provided by [5].

The test setup requires test control information to be exchanged between different components of the test setup. Since it is not desired to apply communication network emulation on this traffic, the traffic shaper has to be configured quite carefully to ensure it does not artificially drop packets which were vital to the proper execution of tests. The network server will, therefore, provide DHCP functionality to the components in the test setup enabling it to keep track of which component has which IP address, as well as ensure that components do not change IP address. This is helpful to identify each component, however, a single component can send both traffic on which network characteristics should be emulated and traffic which should not. Therefore, the traffic shaper cannot filter traffic based on IP addresses alone, and must use transport layer identifiers as well. This careful packet filtering sparked the development of a more automated system developed in [C].

This automated system implements a database on a separate PC containing all IP addresses and transport layer port numbers used for communication during testing. It also contained the communication network models to be used by the traffic shaper. A communication protocol between the database and the network server was defined, and a user interface was designed to ease the use of the network emulation. This solution hides the



### 3. Summary and Conclusions

complex details of the network setup, and enables researchers not from the communication networks field to operate the network setup and run tests within their own field under imperfect network conditions. Finally, the ICT layer includes storage handling for the results generated by tests. This was achieved through a network attached storage. This service would store network traces from the communication network emulation, as well as having an open interface to allow control and power engineers to store results centralizing all results on in a single place.

This testbed provided results used to show the impact of communication networks on control performance in Paper [F], but was also the basis of numerous other publications otherwise unrelated to this dissertation (e.g. [6], [1], [7]).

## 3 Summary and Conclusions

Three different simulation frameworks were presented, each with its own unique contribution to the research conducted in this dissertation. The first allowed for the simulation of very complex communication scenarios in conjunction with accurate control simulations. The second allowed simpler communication scenarios, however, with the added benefit of using power grid and control models without modifications and with the added benefit of faster execution times. The final simulation framework took a mathematical approach to simulating communication networks allowing simulation of information quality metrics confirming their validity. Finally an experimental test setup was designed to obtain results closer to real world smart grid functionality implementation than was possible with the simulation frameworks, at the cost of the slow execution time of a testbed running in real time. This test setup included extensive communication network emulation implementations to allow easy configuration. All these evaluation methodologies will be used through out this dissertation to validate hypotheses through the remaining chapters. Through this chapter we can now answer Question 1 from Section 2. Evaluating smart grid functionalities can be done in several different ways as a trade-off between the level of detail and the evaluation execution time. Experimental tests can show a very high level of detail which helps gain higher confidence in the results, at the cost of not only expensive equipment and development time, but also very slow execution times since tests are running in real time. Evaluation through simulation can be implemented significantly faster, and will also be able to simulate a control system significantly faster than real-time. However, even between simulation frameworks a similar effect occurs where higher complexity results in slower execution time.

## References

- [1] S. Bessler, M. S. Kemal, N. Silva, R. Olsen, F. Iov, D. Drenjanac, and H. Schwefel, "Grid-aware demand management in electricity distribution grids," *Sustainable Energy, Grids and Networks*, 2017, under review.
- [2] E. Consortium, "Efficient distribution of green energy(edge)," 2015, <http://kom.aau.dk/project/edge/>.
- [3] S. Consortium, "Supply/demand control algorithms," 2015, <http://smarc2net.eu/public-deliverables/>.
- [4] —, "Testbed use case and framework specification," 2015, <http://smarc2net.eu/public-deliverables/>.
- [5] M. Findrik, "Network-aware adaptation framework and its applications to smart grid controllers," Ph.D. dissertation, 2016.
- [6] M. S. Kemal, R. Pedersen, F. Iov, and R. Olsen, "Disc-opal: A simulation framework for real-time assessment of distribution grids," in *Workshop on Modeling and Simulation of Cyber-Physical Energy Systems*, 2017.
- [7] M. S. Kemal, L. Petersen, F. Iov, and R. Olsen, "A real time open access platform towards proof of concept for smart grid applications," *Journal Of Communication, Navigation, Sensing and Services (CONASENSE)*, 2017.
- [8] T. I. F. Kristensen and J. T. Madsen, "Simulating network adapted market controller in a smart grid scenario," Master's thesis, Aalborg University, 2013, <http://kom.aau.dk/group/13gr1020/>.
- [9] J. Madsen, "On the impact of communication and information access on wind-farm control and demand management in smart grid scenarios," Ph.D. dissertation, 2016, PhD supervisor: Professor Hans-Peter Schwefel, Aalborg University, Denmark Assistant PhD supervisor: Associate Professor Tatiana Kozlova Madsen, Aalborg University, Denmark.
- [10] K. Mets, J. A. Ojea, and C. Develder, "Combining power and communication network simulation for cost-effective smart grid analysis," *IEEE Communications Surveys Tutorials*, vol. 16, no. 3, pp. 1771–1796, Third 2014.
- [11] R. Pedersen, C. Sloth, G. B. Andresen, and R. Wisniewski, "Disc: A simulation framework for distribution system voltage control," in *2015 European Control Conference (ECC)*, July 2015, pp. 1056–1063.
- [12] O.-R. Technologies, "Opal-rt," 2017, <http://www.opal-rt.com/>.

## Chapter 4

# Communication Networks in Smart Grids Energy Balancing Controllers

In order to investigate Question 2 of the problem statement in section 2, this chapter studies the impact of imperfect communication networks in smart grid energy balancing controllers. This is done to investigate which problems an imperfect communication network causes in a control system so efforts can be directed to areas of study where improvements are most useful. This chapter also investigates how specific energy balancing controller can be adapted to take communication network performance into account to improve the overall control system performance.

### 1 Communication in Smart Grid Energy Balancing

This section will firstly give a short overview of the use case defined in [1] used for this study case. The main focus of the use case is to show the feasibility of controlling flexible power producers and consumers over an imperfect communication network. It also aims to show how assets in LV grids can be aggregated through a LV grid controller(LVGC), and provide flexibility to a higher hierarchical controller in the grid. This use case aims to firstly control the voltages in the LV grid, and secondly, optimize grid losses and energy costs. The voltage control part of this use case relevant for this dissertation is described in chapter 6, whereas loss optimization will be described in this section in the form of energy balancing control over heterogenous communication networks.

The use case is evaluated against a benchmark grid developed in [2]. The

benchmark grid is developed based on topology and consumption data from the power grid of a small danish town. To develop a grid where smart grid functionalities can be tested and properly evaluated, the benchmark grid should be a weak grid with high penetration of Photo-voltaic panels resulting in fluctuating voltages with a higher risk of voltage problems. The particular danish power grid on which the benchmark grid is based was chosen as it has many of these features. With the increasing popularity of photo-voltaic panels in residential areas, and the weak grid design, it is expected that current grid control design will not be sufficient in the future. The topology of the benchmark grid and an overview of the control structure is shown in Figure 4.1.

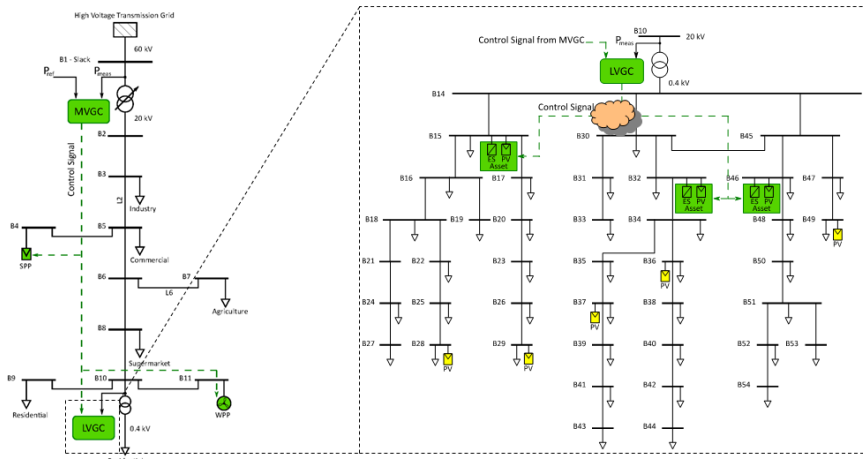

Fig. 4.1: Hierarchical control architecture visualized within the benchmark grid

As the control is imposed on the benchmark grid, flexible assets also have to be added to the grid. Three such assets are placed in the grid, with each asset consisting of a controllable photo-voltaic panel and a flexible storage unit. The assets are based on models also developed in [2].

Having a high speed reliable communication network connecting the power grid would be very expensive to implement as in most areas no such infrastructure is currently implemented. For this reason, this dissertation investigates the usage of already existing communication infrastructures. This could be the already existing cellular technologies used in mobile communication, existing DSL connections, or even utilizing the power lines as communication medium in Power Line Communication (PLC). The attached paper [F] investigates the impact of communication networks on energy balancing control performance. In the paper, energy balancing controllers are put into the benchmark grid, and tested in the HIL experimental setup with periodical in-

## 2. Communication network based controller adaptation

formation updates from assets to the controller. For the communication network both losses and delays are modelled based on measurements of a PLC network setup from [4]. Losses are modelled as independent random packet drops, whereas delays are modelled by replaying the delay measurements at obtained in [4]. In [F] it is shown that the energy balancing controller developed in [3] have a very high resilience to the poor network conditions of PLC. The paper then moves on to gain a deeper understanding of the impact of communication parameters on control performance by sweeping communication network parameters to understand the limits of the controllers resilience to network conditions. For this analysis, the DiSC simulation tool is used in favor of the HIL experimental setup due to its significantly faster evaluation time making it feasible to sweep a larger parameter space as well as make repeated simulations to investigate statistical significance. This study shows delays should be more than six times the control period before a significant decrease in control performance can be observed. With the slow control period of the energy balancing controller of one minute, in networks under normal operating conditions, delays should rarely be a hinderance for proper control performance when considering such slow controllers. Similarly, the study concluded packet losses should exceed 60% before the control performance started to degrade significantly. Though 60% packet losses is rarely experienced on communication networks under normal operating conditions, [4] shows how packet losses in this range is experienced in heavily loaded communication networks.

## 2 Communication network based controller adaptation

This section goes through the specific energy balancing control example described in detail in Paper [A]. Through this example we gain insights into the complexities that arises from evaluating both the disciplines of communication networks and control theory together, and why this is necessary. It is also shown how communication network conditions can be taken into account and improve overall system performance in highly lossy networks.

The goal of this scenario is to reduce power consumption during peak hours by utilizing a fleet of controllable refrigerators, which the controller can turn on or off. By sending energy turning refrigerators on before peak consumption hours, energy in the form of "coldness" can be stored in the refrigerators allowing them to be turned off during peak hours, and lessen the peak strain on the power grid. The controller is provided a power reference to follow, which should be designed, by a higher hierarchical controller, to increase shortly before the peak hours letting the controller know to start

storing energy in the refrigerators. By putting the controller into the secondary substation, it can measure the total power grid consumption using a co-located sensor on which communication network performance has insignificant impact. This power measure is then compared to the provided reference to determine if refrigerators should be turned on or off. If the controller determines that 20% of the refrigerators currently turned off need to be turned on, it will broadcast a value of 0,2 to every refrigerator, which will probabilistically choose to turn on with a 20% probability. Similarly, if 20% of refrigerators currently on should be turned off, the controller would broadcast a value of  $-0,2$ . To calculate the control signal, the controller must have an estimate of the number of refrigerators in the on/off state. Therefore, each refrigerator will return its current state every time a control signal is received.

The controller is assumed connected to the refrigerators using a PLC network, and thus the control signal, and the refrigerator state responses are subject to heavy packet losses [5]. As this study precedes the study done in the previous section, the network model is in this case not based on the measurements from [4]. Instead, delays are modelled by limiting the data rate to 3kBps, and randomly dropping packets with a 70% probability. Due to the probabilistic nature of the control signal, the packet loss probability can be taken into account before broadcasting the signal. To do this, the packet loss probability of the network must be known. Similarly, the estimate of refrigerator states can take the packet loss probability into account. Knowing the total number of refrigerators, and assuming packet losses are equally likely in both upstream and downstream directions, the number of received responses can be used to make an online estimation of the packet loss probability:

$$\frac{\hat{N}_{received}}{N} = (1 - P_l)(1 - P_l) \Rightarrow P_l = 1 - \sqrt{\frac{\hat{N}_{received}}{N}}. \quad (4.1)$$

Using this estimate, the control signal can be improved by determining set points based on the estimated number of refrigerators receiving the signal instead of the total number of refrigerators. Similarly, the refrigerator state estimation can be improved by scaling the number of refrigerators in a particular state with the packet loss probability. To determine the validity of this claim, the system is simulated using interdisciplinary simulation framework introduced in Chapter 3 and detailed in paper [A]. This study showed that only taking the packet loss probability into account when determining the control signal decreased control system performance, where as only accounting for packet losses in the refrigerator state estimation showed some improvement in system performance, and adjusting both control signal and state estimation resulted in a significantly improved system performance.

This study shows the complexity of mixing the field of control theory with the communication network field, since optimizing a single estimate

can worsen system performance while still helps to improve performance if done in conjunction with other optimizations. Paper [A] also shows how communication networks can impact control system performance, and how this can be shown using complex inter-disciplinary simulation frameworks.

## 3 Summary and Conclusions

A power grid was modelled based on measurements of a danish distribution grid. To be able to test envisioned control strategies, flexible assets were modelled and added to the grid. This grid model was implemented in the HIL experimental setup, as well as the DiSC simulation tool, and used to test the performance of an energy balancing controller under different communication network conditions. Results showed the energy balancing controller was quite resistant to communication network imperfections. It can from this study be concluded that energy balancing controllers can be designed to function in most communication network under normal operation, and for these controllers future communication network studies should focus on communication networks working outside normal operation i.e. heavily loaded or under malicious attacks. This chapter also showed how an energy balancing controller in a high packet loss scenario can be adapted to account for the packets lost, and gain a significant increase in system performance. This dissertation now switches focus, and considers a voltage controller in the same control architecture as was presented in the first section of this chapter.

## References

- [1] S. Consortium, "Smartc2net revised architecture & use cases," 2014, <http://smartc2net.eu/public-deliverables/>.
- [2] —, "Control framework and models," 2015, <http://smartc2net.eu/public-deliverables/>.
- [3] —, "Supply/demand control algorithms," 2015, <http://smartc2net.eu/public-deliverables/>.
- [4] M. Findrik, R. Pedersen, E. Hasenleithner, C. Sloth, and H.-P. Schwefel, "Test-bed assessment of communication technologies for a power-balancing controller," in *Energy Conference (ENERGYCON), 2016 IEEE International*. United States: IEEE, 2016.
- [5] M. Korke, N. Hosseinzadeh, and T. Moazzeni, "Performance evaluation of a narrowband power line communication for smart grid with noise reduction technique," *IEEE Transactions on Consumer Electronics*, vol. 57, no. 4, pp. 1598–1606, November 2011.

## References



## Chapter 5

# Information Quality Estimation for Event-driven Controllers

This chapter investigates information quality and how it can be defined using the probability of information mismatch ( $mmPr$ ), with the aim of answering question 3 of the problem statement in section 2. The primary goal of a communication network, is to transport information from sender to receiver. Classically, when analyzing its ability to do so, metrics like communication delays and packet losses are usually used. However, which values of these are tolerable is entirely dependent on the information being sent and its usage. Therefore, the notion of information quality is introduced as  $mmPr$ . We define  $mmPr$  as the probability of information being inaccurate at some critical point in time where it is used for actuation. This probability, though dependent on classical metrics, also depends on the information dynamics (how often the information changes at the sender) and the strategy with which the information is accessed. The development of the  $mmPr$  models is described in detail in [D].

### 1 Mismatch Probability in Event Driven Control Systems

This dissertation considers  $mmPr$  in event driven control systems. Event driven controllers are characterized by only performing control actions if an event occurs where the control system is outside its bounds. The more unstable the system becomes, the lower the advantage of event driven control,

and classical periodical control is often chosen. This means the event driven controller may lie dormant for the vast majority of the time, changing the requirements for how the information is accessed. As an example, periodical controllers are often used with periodical information updates for obvious reasons, whereas using periodical updates for event driven controllers may result in the vast majority of updates never being used since the controller is inactive. To better understand these differences in information access strategies, three different strategies are investigated. These information access strategies deal with the timings of when updates are transmitted, and how long they are cached at the receiver. Therefore, this is also an obvious place to include communication delays and model the combined age of the information at the moment of actuation. In addition to information age, the mmPr is dependent on the rate with which the information changes at the source, or in general the information dynamics explored in detail in section 1.2. Collectively this gives the mathematical calculation of mmPr:

$$Pr(mm) = \int_0^{\infty} Pr(mm|t)f_{infoAge}(t)dt, \quad (5.1)$$

where  $Pr(mm|t)$  is the probability of an information mismatch given an information age  $t$  or the information dynamics, and  $f_{infoAge}(t)$  is the probability density function of the information age.

## 1.1 Modelling Information Age

To model information age, it is important to know the pattern with which the information is accessed, and how to define the critical point in time where the information is used for actuation. In the previous mmPr models, [1] information is sent from source to destination and then actuated upon, whereas control systems are characterized by a controller collecting information, calculating set-points, and distributing these to actuators. For this reason, old models cannot be directly used, and new models are developed for different information access strategies. In this section three information access strategies are considered: reactive information access, proactive periodical information access, and proactive event driven information access. In addition to being evaluated as part of the mmPr calculations, the three access strategies are compared on two metrics, firstly, the mismatching time, which is the time period in which a change in information would lead to an information mismatch, and secondly, the response time, which is the time from the control triggering event occurs, until the controller determined set-points have been distributed to the relevant assets. When modelling information age, we assume a communication delay for transmitting the information upstream given by the distribution  $f_u$ , and a communication delay for transmitting downstream distributed as  $f_d$ .

### Reactive Information Access

In the Reactive information access strategy, the controller will ask assets for information whenever it is needed. As illustrated on Figure 5.1, this strategy keeps the mismatching time very low, at the cost of longer response times. In addition to this, the reactive information access strategy has a more complex impact on the communication networks. In contrast to proactive strategies, the reactive access strategy only transmits information when it is needed, resulting in no unnecessary packets being transmitted. However, in scenarios with multiple assets, when an event occurs, the controller would send a burst of packets asking all assets for updated information making all assets respond at approximately the same time. Though bursty traffic patterns can have great impact on communication network performance, it is not considered further in this dissertation but rather left for future study.

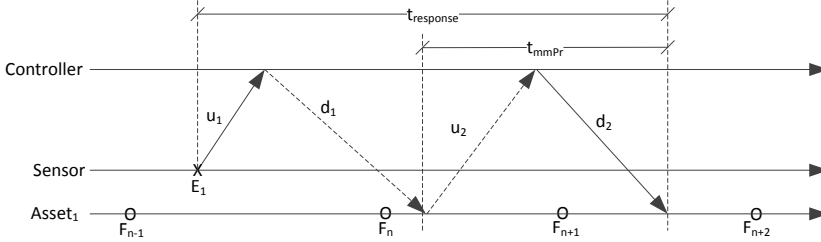

**Fig. 5.1:** Message sequence diagram showing the information flow when a sensor detects a control triggering event using the reactive approach to access flexibility information.

Mathematically, this strategy is modelled as a convolution of the distribution of each information delay contribution. We also model the response time which similarly is a convolution of the distributions of the different contributions:

$$f_{mmPr,rea} = (f_u * f_d)(t) \quad (5.2)$$

$$f_{infoAge,rea} = (f_u * f_u * f_d * f_d)(t) \quad (5.3)$$

The information age at the time of set-point implementation is given by the communication delay of the transmission of the information and the communication delay of the set-point transmission. Since both of these transmissions are necessary for system functionality, this is the lowest information age one could expect from the system. However, this comes at the cost of the response time being defined by two transmissions in each direction.

### Proactive Periodical Information Access

Periodical information updates are the standard in classical control systems, both because they are simple to implement and because they fit well with the

periodical behavior of classical control systems. However, for event driven controllers, periodical information updates will transmit a lot of unused packets as shown in Figure 5.2. This means there is a trade-off between wasting network resources, and keeping the mismatching time low, as information will have to be cached at the controller between updates. Proactive strategies, however, have a very low response time since there is no time spent waiting for the information.

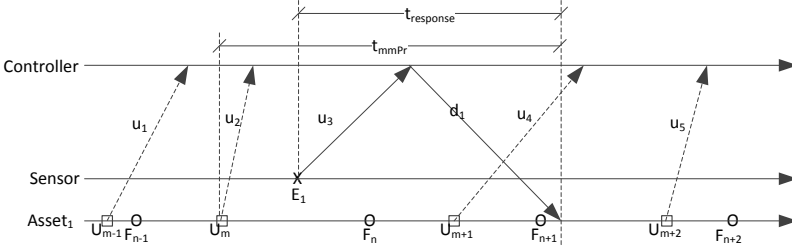

Fig. 5.2: Message sequence diagram showing information flow when flexibility information is accessed periodically independent of control events.

This strategy is, similarly to the reactive strategy, modelled by a convolution of the different delay contributions. However, the caching of the information at controller complicates things a bit. Assuming the period is Poisson distributed with a constant rate of  $\tau$  simplifies calculations greatly, which is why Poisson distributed periods are assumed though it would in practice often be deterministic. Selecting a proper value for  $\tau$  will only be considered shortly in section 2. Making this assumption, the information transmission delay can be combined with the caching time  $f_w$ , giving the following information models:

$$f_{mmPr,per} = (f_d * f_w)(t) \quad (5.4)$$

$$f_w = \exp(-\tau \int_0^t F_u(v) dv) \tau F_u(t) \quad (5.5)$$

$$f_{infoAge,per} = (f_u * f_d)(t) \quad (5.6)$$

Though the distribution  $f_w$  is not immediately intuitive[D], it is clear that it consists of a transmission delay and some caching time, showing the mismatching time is indeed increased compared to the reactive strategy. In contrast, the response time has effectively been sliced in half compared to the reactive strategy.

### Proactive Event Driven Information Access

The Proactive event driven information access strategy transmits information updates whenever the information changes at the asset. This strategy has the

## 1. Mismatch Probability in Event Driven Control Systems

advantages of a proactive strategy with the fast response time, though also having a high mismatching time as illustrated on Figure 5.3. However, due to the dependence on updates when the information changes, the cached values are updated very shortly after the information is changed. This means that the increased mismatching time may not be as significant, the effect of which is shown later during evaluation. Modelling the proactive event driven in-

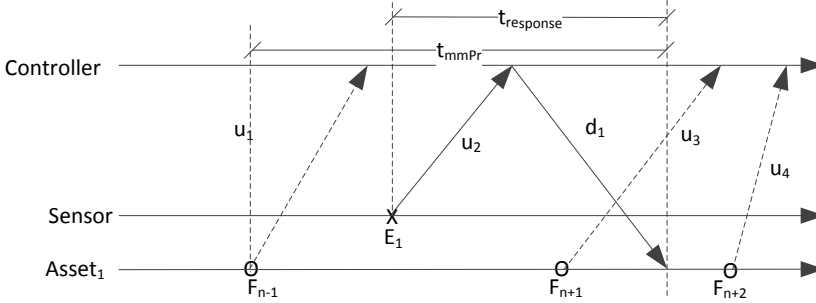

**Fig. 5.3:** Message sequence diagram showing information flow when flexibility information is accessed using the proactive event driven process.

formation access strategy becomes mathematically complex due to the direct dependence between information changes and update times. This dependence increased the mathematical complexity to the point where no feasible model for the information age in this strategy was found, and only the response time is modelled:

$$f_{infoAge,ev} = (f_u * f_d)(t) \quad (5.7)$$

The response time is unsurprisingly the same as for the proactive periodical information access strategy. Similarly, the information age would also consist of a communication delay, a caching period, and a second communication delay, only with this strategy it is known that the information changed at the asset just before transmission, whereas the value may have been cached for a while at the asset in the periodical strategy. Since no mathematical model for this strategy exists, this strategy is left out in some of the further studies performed in [G]. However, this strategy will be compared to the other two through simulation studies later in this chapter.

## 1.2 Modelling Information Dynamics

In this section, we investigate different ways of modelling information dynamics, and how these can be mapped into  $Pr(mm|t)$  in order to integrate it into the mmPr estimation. [2] models assets as continuous MATLAB algorithms showing the dynamics of different asset types (PV panels, Wind

turbines, etc.). The continuous nature of these models makes them unsuited for mmPr calculations since information mismatches are not trivial to define in continuous measurement space since a tiny variation in the measurement would lead to a theoretical mismatch. Instead, it was attempted to map these models into discretized models in [3]. Here, the models were sampled, and the dynamics mapped into continuous time Markov chains. We consider flexibility information used by the controller to determine set-points, here, it is assumed that having more flexibility available than expected should not hinder proper set-point implementation at the asset. This means that only when the information changes to a lower flexibility state in the Markov chain can it cause decreased control performance. Therefore, an information mismatch is defined as the available flexibility being lower at the time of set-point implementation than it was when uploaded from the asset. Markov chains provide some nice properties when modelling probabilistic stateful systems as they can be represented by a generator matrix  $\mathbf{Q}$ , from which stationary probabilities  $\pi$  can be derived, and from there  $Pr(mm|t)$ :  $\pi$

$$\pi\mathbf{Q} = \mathbf{0} \quad (5.8)$$

$$\sum_i \pi_i = 1 \quad (5.9)$$

$$Pr(mm|t) = \sum_{i=1}^M \left( \pi_i \sum_{j=1}^{i-1} p_{ij}(t) \right) \quad (5.10)$$

Discretizing begs the question, which discretization level to choose. Since the mmPr measure is purely a mathematical construct, this level can in theory be chosen arbitrarily, however, in practice this choice does have ramifications. Picking a coarse granularity means splitting a continuous signal into only a few states possibly losing finer dynamics of the information significant to control performance. On the other hand, choosing a fine granularity increases the dimensions of the generator matrix  $\mathbf{Q}$  increasing the computational complexity at a rate of  $O(n^3)$ . Additionally, the mmPr value is increased with the granularity, as a system with few states has a greater propability to be in a matching state due to pure chance. When introducing model estimation giving the models some uncertainty, the chosen granularity can be used to increase the mmPr making values in regions with low mmPr easier to distinguish at the cost of making regions with high mmPr values harder to distinguish. We also note that when discretizing a continuous signal into a Markov chain, the chain becomes a birth/death chain for sufficiently high granularity giving the model additional mathematical features, however, none of the models used for this dissertation takes advantage of any birth/death chain characteristics. Granularity determination is studied in further details in [4]. Ideally, mmPr estimation would be used in systems with already dis-

cretized information dynamics e.g like the on/off state of heat pumps though continuous information sources are more common in smart grid applications.

## 2 Simulation Verification

To determine the validity of the developed mmPr models, a simulation study is done. For simplicity, exponentially distributed symmetric network delays are assumed, additionally, the Markovian information model is assumed to be a birth/death chain with equal transition rates for all transitions (i.e.  $\lambda_{ij} = \lambda$  where  $j = i + 1$  for  $i < M$  and  $j = i - 1$  for  $i > 1$ ). For all details on the simulation study see [D]. Figure 5.4 shows the densities of the mismatching times for each information access strategy. Since no model was found for the proactive event driven strategy, the distribution of this is estimated based on simulations, and fitted with a standard MATLAB tool which is the reason this model has density mass below zero, though this would not make sense in practice. Figure 5.4 shows the reactive strategy to have the lowest mismatching time density as expected from the modelling, with the proactive event driven strategy having density mass at significantly higher time values than both the reactive and the proactive periodical strategies. As expected, Figure 5.5 shows the two proactive strategies having identical response times, with the reactive strategy having significantly higher response times.

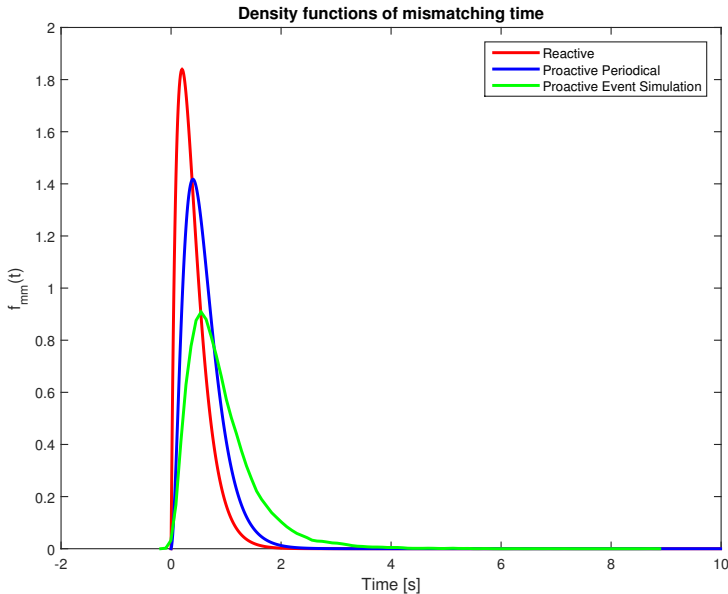

**Fig. 5.4:** Density functions of mismatching time showing how the reactive scheme provides the smallest mismatching time of the three.

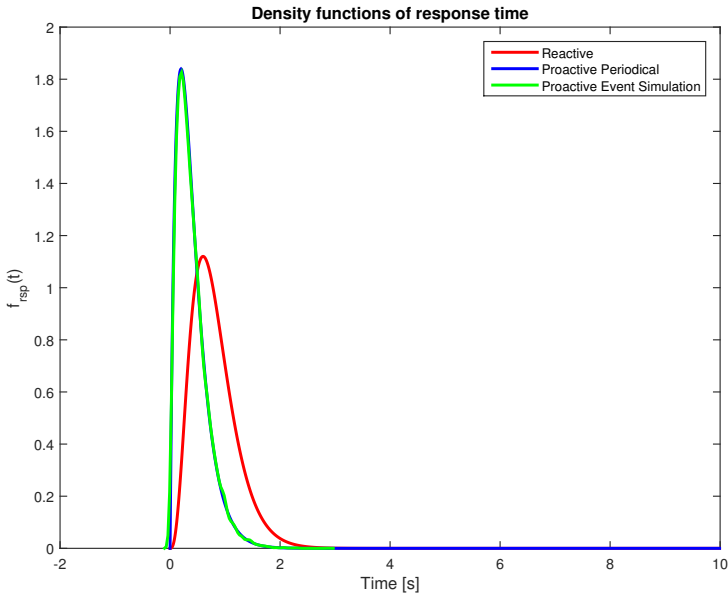

Fig. 5.5: Density functions of response time showing the reactive scheme providing higher response times than the two other schemes.

Simply considering these two figures, the significantly increased mismatching time of the proactive event driven strategy would suggest this strategy gives a higher mmPr than the other strategies. However, considering the mmPr with varying communication delays produces Figure 5.6. Here, it is shown that for low delays, the reactive strategy performs better than the proactive periodical strategy. For sufficiently high delays, this shifts, and the proactive periodical strategy performs better than the reactive strategy. From the simulations, the proactive event driven strategy surprisingly follows the best performing of either of the other strategies for all values of communication delays. This shows how the complex dependencies in the proactive event driven strategy works to lessen the importance of mismatching times, to the point where this strategy seems to have the best qualities of both of the other strategies.

Along with the proactive event driven strategy, the other strategies were also simulated to determine the validity of the models. The comparisons between these simulations and the analytical models are shown in Figures 5.7 and 5.8. These comparisons did not fit within the scope of [D] and are, for this reason, shown here.

Further studies have been conducted into the network resources consumed by each strategy and the effects of varying the update period of the proactive periodical strategy. These studies are detailed in [D], in this section we simply note that by choosing a high update rate, the mmPr value can



### 3. Summary and Conclusions

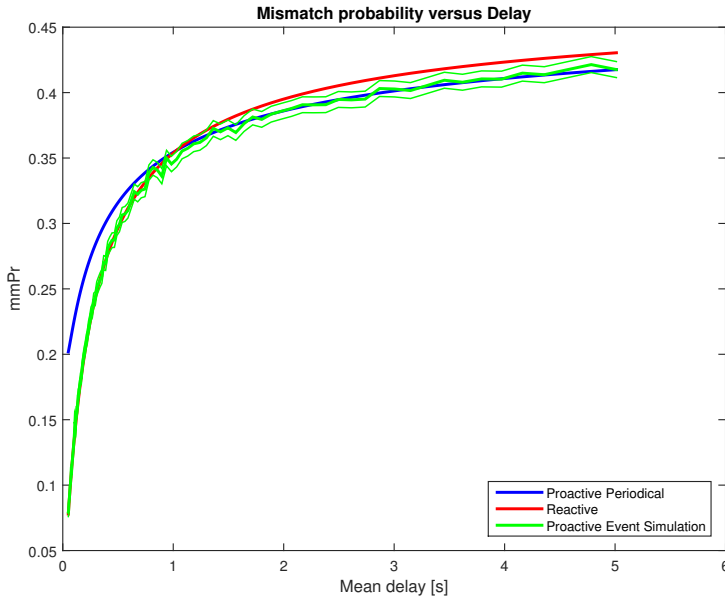

Fig. 5.6: Mismatch probability versus Delay. Shown with 95% confidence intervals in dashed lines for the simulated results.

be picked arbitrarily low as long as network congestion is not considered. Conclusively, Figure 5.9 shows the relationship between mmPr and response times for the three information access strategies with varying update period for the proactive periodical strategy.

### 3 Summary and Conclusions

In this chapter, mmPr was considered for three different information access strategies; Reactive, Proactive periodical, and proactive event driven for the scenario of event driven controllers. Of these three, the mathematics of the proactive event driven model proved too complex for a feasible model to be developed, whereas, models were developed and verified for the two remaining information access strategies.

Looking at the mmPr values generated by the two developed models, no access strategy can be considered better than the other since the optimal choice depends on the parameters of the system (e.g. Figure 5.6 shows the reactive access strategy being superior for low delay values but not for high delay values.). However, simulation studies showed that the proactive event driven access scheme performed similarly to the best of the other strategies for all delay values.

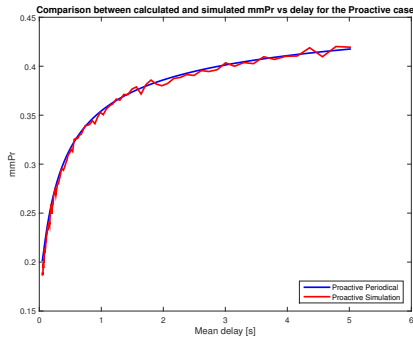

Fig. 5.7: Comparison between simulated and analytical mmPr for the proactive periodical strategy.

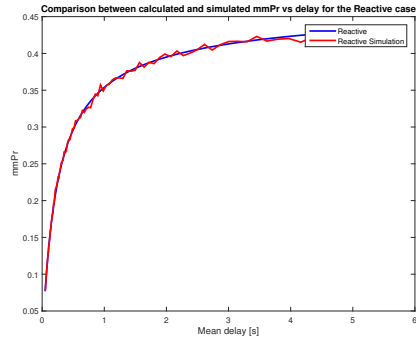

Fig. 5.8: Comparison between simulated and analytical mmPr for the reactive strategy.

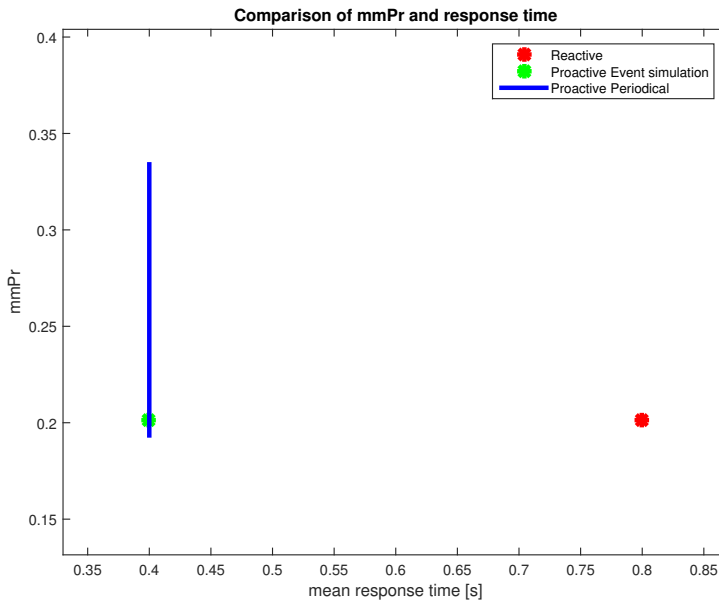

Fig. 5.9: Mismatch probability versus response time.

Due to the fact that no feasible model was found for the proactive event driven information access strategy, this strategy will not be considered further in this dissertation. The Reactive and the Proactive periodical strategies will however be linked to control performance in the following chapter.

## References

- [1] M. Bøgsted, R. L. Olsen, and H.-P. Schwefel, "Probabilistic models for access strategies to dynamic information elements," *Performance Evaluation*, vol. 67, no. 1, pp. 43 – 60, 2010. [Online]. Available: <http://www.sciencedirect.com/science/article/pii/S0166531609001175>
- [2] S. Consortium, "Control framework and models," 2015, <http://smarc2net.eu/public-deliverables/>.
- [3] —, "Final results from laboratory tests," 2015, <http://smarc2net.eu/public-deliverables/>.
- [4] R. L. Olsen, J. G. Rasmussen, H.-P. Schwefel, and J. T. Madsen, "On the use of information quality in stochastic networked control systems," *Elsevier Journal of Computer Networks*, 2017.

## References

## Chapter 6

# Mismatch Probability in Voltage Control

This chapter will dwell deeper into the link between the mmPr metric defined in chapter 5 and overall system performance in order to attempt an answer to question 4 of the problem statement in section 2. To do so a control scenario must be defined on which to make the analysis. Papers [A] and [F] and Chapter 4 used energy balancing controllers which follows a reference as closely as possible. However, since the defined mmPr models focuses on event-driven controllers, reference tracking controllers are not suitable for the analyses performed in this chapter. For this reason an event-driven voltage control scenario is defined.

### 1 Voltage Control Scenario

The voltage control scenario is based on the same power grid model as the energy balancing scenario considered in Paper [F] shown in Figure 6.1.

The voltage controller is triggered by voltage events measured at a sensor or smart meter which sends a message to the controller that voltage has crossed a threshold. Two such thresholds exist, one if the voltage comes close to its upper bound, and one for its lower bound. These bounds are defined by the grid codes enforced in the particular grid, and thresholds should be designed so the controller can get the voltage levels into normal operating range before the bounds are broken. Upon event triggering, the controller starts to calculate and distribute setpoints periodically to the controllable assets in the grid. This chapter covers two separate studies, Section 2 Paper [E] look into how information access can be adapted to optimize control performance both for the event-driven phase of the controller and in the periodical

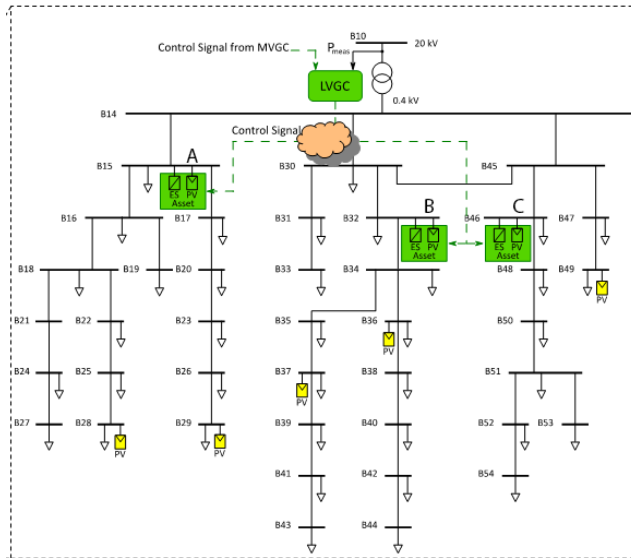

**Fig. 6.1:** Control and communication architecture visualized on top of an example low voltage grid with three controllable assets. The evaluation results in later sections focus on the three busses marked with A, B and C.

control phase following the event. Paper [G] goes deeper into the link between the event-driven phase and mmPr. For these reasons, two slightly different controllers are used as to better put emphasis on the relevant control periods. Both controllers only calculate set-points based on information local to the asset for which set-points are determined. This removes the need for a single centralized controller, however, more advanced controllers utilizing distributed information are envisioned for future smart grid voltage control [1]. The simple controllers considered here are only considered as to not focus on controller design, but rather information access impact.

## 2 Control performance Optimization with Multiple Assets

This section investigates how the mmPr models developed in Paper [D] can be used to adapt information access strategies to optimize voltage control performance when considering multiple controllable assets. The controller used in this section follows the algorithm shown below, and was designed to show both the event driven phase and the periodical phase:

Paper [D] considers two ways of optimizing information access; one for

## 2. Control performance Optimization with Multiple Assets

```

read  $V_{measured,i}, i \in BUS;$ 
if  $V_{measured} > 1.05$  then
   $err = V_{measured} - 1.05;$ 
   $P_{max\ bus\ i} = P_{injected\_i} + K_p * err + K_i * \int_{t_{V_m > 1.05}}^{t_{V_m < 1.05}} err(\tau) d\tau$ 
  for  $b \in X$  do
     $P_{max\ bus\ b} = P_{injected\_b} + K_p * err + K_i * \int_{t_{V_m > 1.05}}^{t_{V_m < 1.05}} err(\tau) d\tau$ 
  end
end

```

**Algorithm 1:** PI control algorithm for stabilizing the voltage at the bus  $i$  utilizing PVs at the bus  $i$  and the upstream buses  $b \in X$

the event driven phase, and one for the periodical phase. Information access optimization for the periodical phase is based on mmPr models developed by [2], and determines the time assets should transmit their updates to optimally balance out the probability of the message arriving too late to be used for control actions with the probability of information being accessed so early that its value is outdated before being used by the controller. The specifics of this optimization scheme is described in detail in Paper [D] but will not be covered here as periodical mmPr models are not a contribution of this dissertation.

For the event driven phase, only the mmPr models for the reactive information access scheme was considered. This model was used to determine how long the controller should wait for responses from assets. If the controller has received responses from all assets except one, the missing packet may have been lost in the network and requires retransmission. In this case, it may be better for the controller to continue without the missing packet as to not risk the already received information becomes outdated. Since continuing without a missing packet would result in a definite information mismatch for that particular asset, this optimization is done based on the average mmPr of the assets rather than the combined mmPr for the assets. This means the reactive mmPr model from Chapter 5 is extended to  $N$  assets by conditioning on the number of responses that are received and averaging over all assets.

$$mmPr_{rea,N} = \sum_{n=0}^N \frac{n \cdot mmPr_{rea,1} + (N - n)1}{N} \cdot Pr(n \text{ responses arrive}) \quad (6.1)$$

Paper [D] shows how these optimization significantly decreases the impact of communication delays on control performance. Especially, it is shown that the impact of increasing delays are much smaller when using the proposed optimizations as doubling the delay causes a 30% decrease in control performance without optimization, but only a slightly decreased control

performance with the optimization. This study shows the real world applications of the mmPr metric, however, specifics on which of the two optimization schemes made which impact was not clear. The following section removes the optimization of the periodical control phase to make further studies into the impact of event driven mmPr models on control performance.

### 3 Event Driven mmPr Impact on Control Performance

To further study the impact of the event driven control phase, Paper [G] implements a simple Droop controller. This controller only controls reactive power implemented as follows:

$$uRef_Q(t) = G_D * (1 - |V_i(t)|/V_{base}) \quad (6.2)$$

with  $V_i(t)$  being the measured voltage at time  $t$  and  $V_{base}$  the nominal voltage, which for the Danish grid in low voltage is 400V. The droop gain,  $G_D$ , for the asset is set to 200.000 for this control scenario. This very high droop gain results in control actions being very aggressive making the periodical control phase as short as possible to highlight the impact of event driven mmPr on control performance. For this controller, control performance is defined as the number of voltage violations occurring during each simulation simulating 12 hours of power grid operation.

To perform this study, the DiSC tool is used to simulate the behavior of the distribution grid. Simulations are performed with reactive and periodical information access strategies. Based on these simulations, Paper [G] discretized voltage measurements from the assets and fits them to a Markov model to enable mmPr estimations. It is then shown how a classical communication network metric like information age would be identical for each asset, whereas the mmPr metric show how the information dynamics can cause differences in the asset information quality. Figure 6.2 shows how distinguishing between busses can be very important for control performance, as it turns out that even without control, Bus C rarely experiences any voltage violations, whereas Bus A requires a lot of controller attention.

A positive correlation is also shown between mmPr models and control performance, especially for the periodic information access strategy as shown in Figure 6.3. This similar qualitative behavior of mmPr and control performance metrics, means mmPr could be used to identify delay ranges and update period intervals expected to impact voltage control performance.

From the results obtained in [G], though a strong link was found between mmPr and control performance, the mathematical models did not properly



### 3. Event Driven mmPr Impact on Control Performance

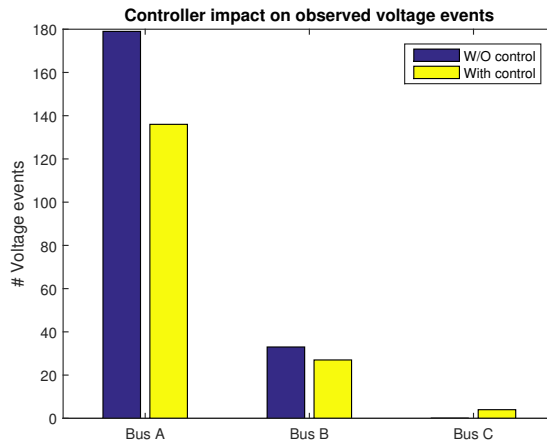

**Fig. 6.2:** Voltage bound violations on buses with controllable assets; voltage control uses ideal information access and ideal setpoint communication.

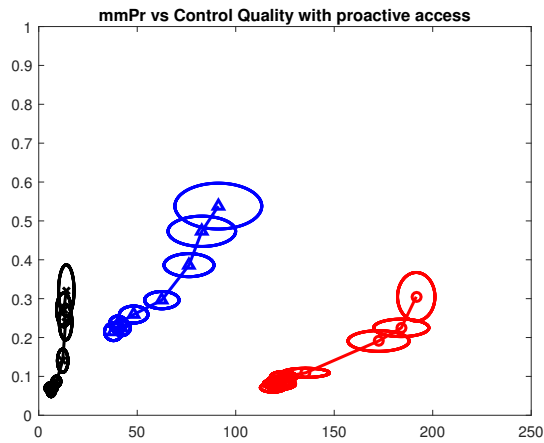

**Fig. 6.3:** mmPr vs system performance for the voltage controller with periodic information access.

match the simulated values hinting that further research is needed on improving information modelling procedures.

## 4 Summary and Conclusions

This chapter introduced a voltage control scenario to be used to evaluate the mmPr models developed in [D]. In this scenario, mmPr models were used to increase control performance by determining optimal timings for information interaction. This was done both for the controllers periodical and event driven phases. The event driven phase was then moved further into focus by changing the controller to a more aggressive one to shorten the periodical phase. In this setting, the link between mmPr and control performance was studied, and the two share the same qualitative behavior making the mmPr metric superior to information age for determining relevant ranges for network parameters where control performance improvements can be expected. From this chapter it can be concluded that mmPr can be a useful link between smart grid control performance and communication network conditions, though it can also be concluded that current information modelling procedures are insufficient to accurately model mmPr.

## References

- [1] A. Bidram and A. Davoudi, "Hierarchical structure of microgrids control system," *IEEE Transactions on Smart Grid*, vol. 3, no. 4, pp. 1963–1976, Dec 2012.
- [2] M. Findrik, J. Groenbaek, and R. L. Olsen, "Scheduling data access in smart grid networks utilizing context information," in *2014 IEEE International Conference on Smart Grid Communications (SmartGridComm)*, Nov 2014, pp. 302–307.

## Chapter 7

# Conclusion and Outlook

This dissertation mainly aimed to investigate the hypothesis: **It is hypothesized that poor network performance causes grid control performance degradation, and that using information quality metrics can be beneficial as an intermediate link between communication network Quality of Service metrics and control performance.** To perform this investigation, grid control performance needed to be evaluated which sparked the development of several evaluation frameworks in chapter 3. These frameworks were used to evaluate the first part of the hypothesis dealing with grid control performance degradation caused by imperfect communication networks. This part of the hypothesis was confirmed first in chapter 4 with an energy balancing controller. However, this controller did show a very strong resilience to communication network imperfections hinting that the communication network challenges for energy balancing controllers does not lie within normal network operation, but rather in scenarios with heavy network load, or for operation during malicious communication activities.

The grid control performance degradation caused by imperfect communication network conditions was also shown in the voltage control scenarios investigated in chapter 6.

The second part of the hypothesis deals with the use of information quality metrics to link communication network performance to control performance. To determine this link, the information quality metric mmPr was introduced. The already established idea of mmPr was extended to not only consider the gathering of information, but also the actuation based upon the information. Further more, it was extended to fit the communication patterns of event driven controllers. Chapter 5 considers three different information access strategies for modelling mmPr. Though the chapter shows mmPr models for the Reactive and Proactive periodical information access strategies, a mathematical model for the Proactive event driven strategy was not found.

Further studies into the development of a suitable model for the proactive event driven access strategy are left for future work. Further research into more accurate mmPr models can also be useful, for example by including packet losses into the modelling. For actual implementation, online estimation of information models would be very useful, since every bus in a complete power grid would not be feasible to do manually.

Linking the developed mmPr models to control performance was attempted in Chapter 6, where the mmPr concept was proven to be a beneficial information quality metric to link communication network performance to control performance. Though a beneficial link was established, simulation studies also revealed the information dynamics modelling approach to be insufficient for accurate mmPr modelling. Further studies into the information dynamics modelling are left for future research. Chapter 6 shows how the mmPr models can be used to identify communication network parameter ranges in which improvements will have a significant impact on control performance. Further studies into how such improvements can be implemented in a networked control system are still missing.

**Part II**

**Papers**



# Paper A

## Utilizing Network QoS for Dependability of Adaptive Smart Grid Control

Jacob Theilgaard Madsen, Thomas le Fevre Kristensen, Rasmus  
L. Olsen Hans-Peter Schwefel, Luminita C. Totu

The paper has been published in the  
*Energy Conference (ENERGYCON), 2014 IEEE International* pp. 859-866, 2014.

© 2014 IEEE

*The layout has been revised.*

## Abstract

*A smart grid is a complex system consisting of a wide range of electric grid components, entities controlling power distribution, generation and consumption, and a communication network supporting data exchange. This paper focuses on the influence of imperfect network conditions on smart grid controllers, and how this can be counteracted by utilizing Quality of Service (QoS) information from the communication network. Such an interface between grid controller and network QoS is particularly relevant for smart grid scenarios that use third party communication network infrastructure, where modification of networking and lower layer protocols are impossible. This paper defines a middleware solution for adaptation of smart grid control, which uses network QoS information and interacts with the smart grid controller to increase dependability. In order to verify the methodology, an example scenario of a low voltage grid controller is simulated under imperfect network conditions.*

## 1 Introduction

Energy production in today's power grid is mainly done using non-renewable energy sources [1], it is, however, desired to rely more and more on several types of renewable energy sources in the future. Private wind turbines and solar panels are gaining popularity at low voltage levels, meaning that energy production is changing from a more centralized system, to a highly distributed system, as well as part of the energy production moving from the high voltage(HV) and medium voltage(MV) layers to the low voltage(LV) layer. To enable the power grid to handle future requirements of a highly dynamic energy production and consumption at this level, it must be possible for the distribution grid to have better control of grid assets.

To facilitate this added control intelligence in smart grid systems, a communication infrastructure must be in place as well as functionality to allow grid asset control, which for the LV grid is not yet implemented. Since the assets are highly distributed, dependable communication is required to allow proper grid operation, however, this is not without challenges since several trade-off's have to be made, [2].

Because dependable communication infrastructures tend to be expensive, either a suitable compromise between dependability and price must be found or the dependability of economically feasible communication infrastructures must be increased. Therefore, low complexity solutions to control grid assets over existing (or low cost deployment communication networks), but imperfect communication networks are required. This paper illustrates the example of asset control in distribution grids with poor communication network performance.



## 1. Introduction

The control scenario in this paper is based on a smart grid communication scenario that uses an open and heterogeneous communication infrastructure [3]. This open communication infrastructure may be a third party public communication network, where the IP stack must be used, and access to lower communication network layers is restricted. The solution proposed in this paper will, therefore, only contain communication network adaptations on layers above the transport layer. A consequence of the use of a public heterogeneous communication network is that QoS will change dynamically over time. This paper presents a solution which adapts a smart grid controller to counteract poor communication network performance, and gain improved controller performance. The conceptual approach of adapting control to network QoS is illustrated in Figure A.1; the figure shows the control loop of grid assets in the outer circle. The required communication infrastructure is monitored and information on the network performance is used to adapt the control approach via middleware functionality. The latter corresponds to the upward red arrow in the figure; the downward direction, adjusting network QoS to control demands, is treated in [3] but beyond the scope of this paper.

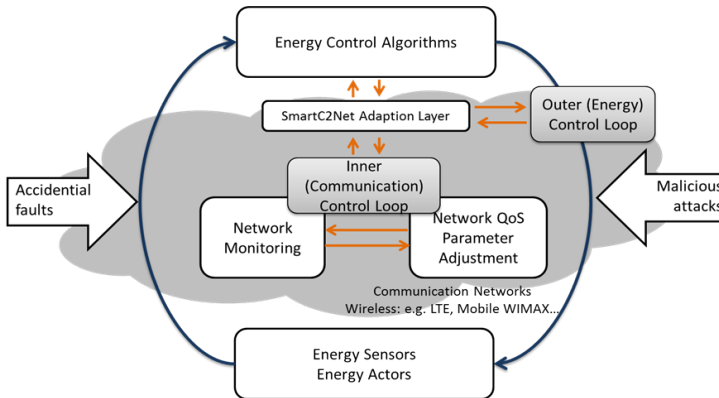

Fig. A.1: Conceptual dual loop for dependable smart grid operation, [3].

The proposed solution will be implemented for a given LV grid controller controlling a population of refrigerators. The adapted controller will then be simulated to illustrate the effectiveness of the adaptation method.

The rest of the paper is structured as follows; first an overview of the existing state-of-the-art is provided. Then, in section 3, an overview of the system architecture and generalized protocol stack is given. Section 4 describes the example control solution as well as the proposal for extension, which realizes the adaptation of the control system to the communication network properties. Section 6 describes the simulation approach and the evaluation results from the simulation experiments, demonstrating the benefits of the proposed

adaptation scheme.

## 2 State of the art

Reference [4] gives an overview of the different technologies available for smart grid communication, and lists the relevant standards. In Ref. [5] the viability of using power line communication (PLC) is investigated through simulation. Two different topologies for the smart grid communication are proposed and then simulated. This paper sets certain requirements that the communication should adhere to, and investigates if it is possible to meet these requirements using PLC. The results show that PLC can fulfill the stated requirements in only a limited set of scenarios, and hence more relaxed communication requirements need to be deployed, or a different communication solution must be used. The poor performance of PLC is also shown in Ref. [6], where it is shown that under certain conditions, bit error rates in the order of  $10^{-2}$  can be expected.

Adapting a control algorithm to the communication network QoS has been discussed in different papers, but it is scenario dependent which adaptation scheme is the most suited for the task. Adaptation should preferably be done without an extensive restructuring of the control algorithm. According to Ref. [7], it is possible to adapt the control algorithm without major changes. The idea is to modify the control loop time while leaving the parameters of the control algorithm unchanged. While this algorithm is not optimal, it can improve the overall performance if the increased control loop time leads to lower communication network traffic, thus ensuring all data in the communication network reaches its destinations before the next sample time. Furthermore, Ref. [7] shows that a control algorithm with variable control loop time will still be stable under certain conditions. A different method for adapting the control algorithm to the communication network state is presented in Ref. [8]. The distributed control algorithm is changed dynamically depending on the QoS of the communication network as estimated by the distributed controllers. This approach changes the control loop time, which either leads suboptimal control, or recalibration of control parameters. Ref. [9] proposes to adapt the network to the controller by choosing the optimal throughput to allocate to based on different power cost functions.

## 3 System architecture and use case

In this section we introduce the system architecture and the example case on which we focus our work. Furthermore, we describe the embedding in the communication stack that allow the transparent adaptation of the controller to changing communication network properties.

### 3.1 System architecture and assumptions

The adaptation approach in this paper focuses on the low-voltage grid controller, whose embedding in a hierarchical overall smart grid control architecture is shown in Figure A.2 [10]. From higher level, the LV grid controller receives set points used as a reference for optimal power consumption. Due to the restricted number of assets in the LV grid, this consumption may not always be achievable, and so, power may flow in and out via the transformer station as needed, but following at best effort the level of a reference signal from the medium voltage (MV) grid controller. However, the in- and out-flux of power between the grid domains should be kept at a minimum for a reliable operation (the more predictable a LV grid domain is to the MV controller, the less effort it is to maintain this, and chances for energy waste is reduced). Toward the MV grid controller, the LV controller thus offers a flexibility service in terms of following set points given by the MV controller. In this paper we focus on the LV grid controller and assume that the set points from the MV grid controller are given.

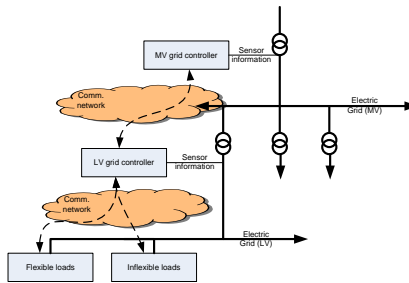

Fig. A.2: Hierarchical Smart Grid control architecture [10].

To achieve the goal of balancing production and consumption, the LV grid controller is envisioned to be able to interact with the assets connected to the LV grid. We distinguish between two different types of assets:

- Flexible loads: These assets may be controlled fully by the LV grid controller.
- Inflexible loads: These assets cannot be controlled, but rather show a stochastic behaviour.

We refer to Ref. [11] for more information on these types of assets. As shown, the LV grid controller needs to interact via a communication network with the assets. In the next section we propose some addition to the communication network protocol stack to improve the controller performance under imperfect network conditions.

### 3.2 Adaptive communication network functionality

We describe a middleware solution that performs adaptation of the control signal and is performed based on the QoS of the used communication network (Downstream Adaptation). Using this middleware, the controller can focus on the originally targeted control operation while the adaptation to changing network performance is taken care of by the middleware. Further, we also propose similar middleware adaptation for access to measured sensor data (Upstream Adaptation). To be able to perform this adaptation based on communication QoS, packet loss estimates must be provided by the network monitoring functions. These QoS estimations can be used to adapt the control signals. The proposed middleware will be placed on the controller side of the communication network for both downstream and upstream adaptation. An overview of the solution and how it interacts with a control system can be seen in Figure A.3.

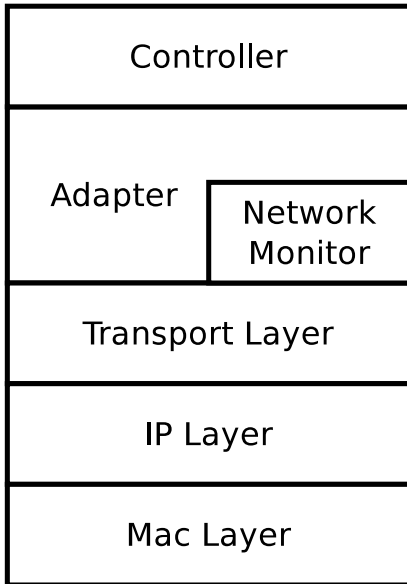

Figure A.3 also illustrates where the adapter and the communication network monitor is placed in the communication network stack. As seen on the figure, the communication network monitor is placed partly between the transport layer and the adaptation layer. This allows the communication network monitoring to be done using passive network monitoring.

Fig. A.3: Illustration showing how the proposed solution is placed in the communication network stack.

## 4 Example Smart Grid Control Scenario

In this section we describe an example LV grid controller scenario that will be controlling the assets as previously described. The scenario considers the

#### 4. Example Smart Grid Control Scenario

control of power consumption of thermostatic loads in a LV grid scenario.

##### 4.1 Regulation of thermostatic loads

A block diagram of the control scenario is shown in Fig. A.4, for which the core design without the communication network, has previously been published in [12]. This structure contains three main elements:

- A number  $N$  of refrigerator units  $F_i$  each equipped with a modified thermostat controller  $K_i$ ,  $i \in \{1...N\}$ , and each with the power consumption  $y_i$ .
- The cumulated inflexible power consumption  $w$  that acts as a predictable disturbance.
- The main controller consisting of the supervisor control, estimation and dispatch blocks.

The objective of the controller in this scenario is to reduce the peaks in the overall power consumption by effectively utilizing the characteristics and restrictions of the grid assets and coordinating the power intake of the asset groups. For the case study we look at thermal energy storage in terms of refrigerators. These refrigerators will by the objective of the control thus be timely coordinated to increase power consumption, and thereby store "coldness", before power peaks caused by the inflexible loads and then coordinated to safely turn off during that peak, and thereby use the previously stored "coldness". For refrigerators, the challenges are that these are restricted in terms of operating temperatures, which from time to time disallow operation of them as desired.

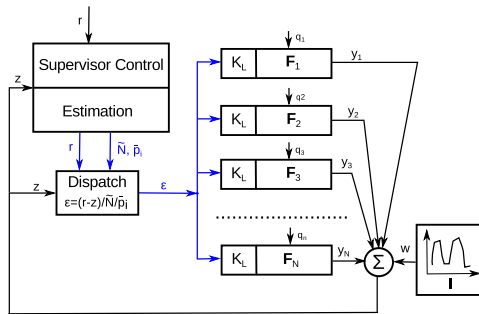

Fig. A.4: Control of thermostatic loads [12].

The operation of the control algorithm can be sketched as follows:

```

for each minute do
  Estimate Refrigerators States,  $\tilde{N}^{off}, \tilde{N}^{on}$ ;
  Obtain Power Consumptions,  $z, \bar{p}$ ;
  Compare to reference signal,  $r$ ;
  Calculate Control signal,  $\epsilon$ ;
  Dispatch signal to refrigerators;
  for Each Refrigerator do
    React to received signal,  $\epsilon$ ;
  end
end

```

$\tilde{N}^{on}$ , and  $\tilde{N}^{off}$  are the estimated number of refrigerators that are in the *on* or *off* state.  $z$  and  $\bar{p}$  is the measured power consumption of the LV grid, and the average power consumption of a refrigerator respectively.  $\bar{p}$  is assumed known by the controller, but in practicality would be provided by each refrigerator when registering, and then averaged.

The LV grid controller then coordinates with the MV grid controller, and calculates a power consumption reference  $r$  for a given time horizon, e.g. a day. In this paper we delimit ourselves from deriving the reference signal  $r$ , and the used reference is therefore generated artificially based on the used behaviour of the inflexible loads in the considered LV grid. The exact behaviour of the reference signal is not in focus in this paper, as we want to analyze the concept of adaptations based on imperfect communication networks and not include MV grid control behaviour.

$$\tilde{\epsilon}_k = \begin{cases} \frac{(r_k - z_k)}{\tilde{N}_k^{off} \cdot \bar{p}}, & \text{for } r_k > z_k \\ \frac{(r_k - z_k)}{\tilde{N}_k^{on} \cdot \bar{p}}, & \text{for } r_k < z_k \end{cases} \quad (\text{A.1})$$

$$\epsilon_k = \begin{cases} \tilde{\epsilon}_k, & \text{for } -1 \leq \tilde{\epsilon}_k \leq 1 \\ \text{sign}(\tilde{\epsilon}_k), & \text{otherwise} \end{cases} \quad (\text{A.2})$$

The control signal,  $\epsilon$ , is calculated according to Equation (A.1) and (A.2) and sent to the refrigerators. The control signal indicates the fraction of refrigerators in the right state that should change their state; if  $\epsilon < 0$  then a fraction of  $\epsilon$  refrigerators should switch to the *ON* state, if  $\epsilon > 0$  in the reverse direction. For example, an  $\epsilon$  value of 0.2 indicates a request of the supervisor center for 20% of the refrigerators currently in the *off* state to switch to the *on* state, which as being executed gives an overall increase in power consumption, but at the same time adds to the thermal energy storage in the form of "coldness". Similarly, an  $\epsilon$  value of  $-0.2$  indicates a request of

#### 4. Example Smart Grid Control Scenario

the the supervisor center for 20% of the refrigerators currently in the *on* state to switch to the *off* state, which translates into an overall power consumption decrease, and a loss of "coldness".

The change of state at the  $i$ 'th refrigerator leads to a power consumption,  $y_i$ , in which the total consumption of the refrigerators,  $z$ , are simply the sum of all these. Since there are many other loads on the electrical grid, noises and disturbances,  $w$  (from inflexible loads in this specific scenario), is added to the measured load signal. The controller would need to estimate the controllable load of the refrigerators  $y$ , and thus the average power consumption of a single refrigerator,  $\bar{p}$ , is multiplied by the estimate of how many refrigerators are *on* or how many are *off*. All this happens at discrete points in time, notated by the index  $k$  for the  $k$ 'th step of the control.

In order to ensure that refrigerator temperature (and other potential constraints) are not broken at the individual unit, the actual power consumption decision is taken by the local refrigerator controller  $K_i$ . Every refrigerator in the group receives the same message, in case of perfect communication, and the dispatch is carried out by a local randomization in the following way. If the refrigerator unit is capable, given its local conditions, to safely turn *on* or *off* respectively, it will do so with a  $|\epsilon|$  probability.

In this way, a simple control signal is dispatched to the assets which also respects local constraints of the assets.

#### **Assumptions of the control for thermostatic loads**

The control approach in [12] is based on several assumptions and we briefly review these here. First, the refrigerators have similar, although not identical parameters, and the average parameter values are known by the controller. This resembles a situation where the LV controller has been preconfigured, e.g. via registration of grid assets, such that a set of flexible assets are able to be controlled.

Secondly, the group of refrigerators together with the inflexible consumption are within the same electrical LV grid domain, making it possible to measure the cumulated power consumption  $z$ , for example as illustrated in Figure A.2 at a MV/LV transformer station. Furthermore, it is assumed that the states  $\tilde{N}_k^{off}$  and  $\tilde{N}_k^{on}$  can be estimated accurately by the controller.

The communication in [12] is considered to be done over an ideal link, i.e. the assumption is that all refrigerators receive the control signal and in due time for the control operation.

#### **Modifications of the controller**

In order to fit the controller to the scenario, it has been modified in certain areas.

- The first one regards a change of the  $\epsilon$  calculation. In the original controller described in [12], the control signal  $\epsilon$  is modified such that the controller performs a more aggressive control when the power consumed is above the reference. This aggression has been removed such that the controller attempts to reach the reference exactly, instead of trying to be just below it. The reference signal  $r$  has been lowered accordingly.
- $\tilde{N}^{off}$  and  $\tilde{N}^{on}$  are estimated via feedback from the refrigerators to the controller. After receiving the control command, all refrigerators reply with their (potentially updated) binary state. This feedback was not included in the original controller in Ref [12].

Since the controller has been modified, and a new performance metric is used, the controller can no longer be considered optimal as defined in [12]. This means that control adaptations can cause increased control performance by pure luck. For this reason the controller is recalibrated by changing the  $\epsilon$  calculations to:

$$\epsilon_k = \begin{cases} \frac{(r_k - z_k)}{\tilde{N}_k^{off} \cdot \bar{p}} \cdot C, & \text{for } r_k > z_k \\ \frac{(r_k - z_k)}{\tilde{N}_k^{on} \cdot \bar{p}} \cdot C, & \text{for } r_k < z_k. \end{cases} \quad (\text{A.3})$$

Where  $C$  is a constant. The value of  $C$  is found by simulating the controller under perfect network conditions using different values for  $C$ , and thereby determining its optimal value. This simple recalibration is done as controller design is out of scope of this paper, however, in a practical implementation, a recalculation of control parameters should be done instead.

## 4.2 Communication network

In this scenario we use narrowband PLC for communication between the LV grid controller and each refrigerator. Because we have 60 seconds to dispatch the control signal  $\epsilon$ , communication delays in the ranges of few seconds only have minor impact. However, packet losses are a focus which impact differently for UDP and TCP based protocols, especially for high packet loss communication technologies like PLC.

The parameters of the network scenario that is used in Section 6 for evaluation are listed in Table A.1. We assume a broadcast network with a star topology, for which we can broadcast or multicast the  $\epsilon$  value directly to the assets, and each asset unicast their state back to the controller.

A high packet loss probability of 70% was chosen to illustrate the impact of imperfect network conditions on the controller. The controller was simulated with different values of packet loss, but proved highly resistant to packet losses due to the fact that it was designed with stochastic deviations



#### 4. Example Smart Grid Control Scenario

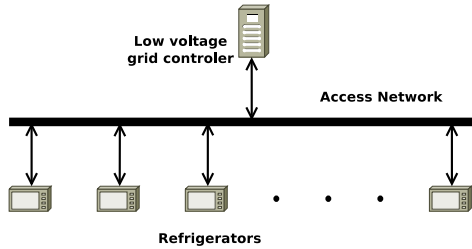

Fig. A.5: Overview of the considered communication network.

Parameter	Value
PLC Packet loss	70[%]
PLC throughput	3000 $[\frac{b}{s}]$
Refrigerators	100
Control interval	60 [s]
Simulation Time	15 [days]
Correction Factor	1,2
Avg. refrigerator power consumption	100 [W]
Refrigerator temperature range	2-5 [°C]
Min. refrigerator on/off time	5 [min]

Table A.1: Parameters used for the simulations.

in mind. As delays does not have a significant impact on the controller in this scenario, the value for the throughput was chosen sufficiently high to support the scenario. Ref. [6] showed that PLC can have BER's as high as  $10^{-2}$ , which for the packet sizes in our scenario translate into 92% packet loss probability. In practice, the impact of bit errors can be reduced by deploying error correcting codes.

### 4.3 QoS-based Adaptive Control

The performance decrease is mainly caused by dropped packets on the communication network. One method to counteract this is to use a reliable transport protocol such as TCP. This does, however, come at the cost of increased delay and overhead, especially compared to UDP, since the control algorithm allows for the use of multi casting. Furthermore TCP becomes very slow in scenarios with high packet loss rates due to its congestion control, or it may even drop connections entirely and then has to perform connection re-establishment. If the overall packet-loss probability can be measured or estimated, the hypothesis is that the control signal can be modified to take into account the loss of recipients by counter adjusting the control signal to the amount of refrigerators expected to receive the signal. The fraction of

refrigerators that should change their state then needs to take into account the predicted message loss to achieve the level of control expected by the controller.

In the considered control system, the control parameter  $\epsilon$  is a measure of the amount of refrigerators which should change state and is calculated based on the amount of available refrigerators in the system,  $N$ . The effective number of reached devices will be smaller than  $N$ , as some refrigerators will not receive the control signal. These become an inflexible unit in practice. To counteract the effect of the packet loss, a new control parameter  $\epsilon'$  is defined, as shown in eq.(A.4). This is calculated from the reduced value of number of nodes that receive the downstream adaptation request,  $N \cdot (1 - P_l)$

$$\epsilon \cdot N = \epsilon' \cdot N \cdot (1 - P_l) \Rightarrow \epsilon' = \frac{\epsilon}{1 - P_l}. \quad (\text{A.4})$$

In this way,  $\epsilon$  is being scaled according to the expected loss of recipients, however, requiring that the packet loss is known.

When a refrigerator receives a control signal from the supervisor center, it will respond with its state information. In scenarios of packet loss, the correct reception of this response message at the controller requires that both the broadcast message and the response message are successfully transmitted. Assuming independent packet loss with probability  $p_l$  in both directions, an estimator of packet loss is obtained from the the number of received response messages as follows:

$$\frac{\hat{N}_{received}}{N} = (1 - P_l)(1 - P_l) \Rightarrow P_l = 1 - \sqrt{\frac{\hat{N}_{received}}{N}}. \quad (\text{A.5})$$

The controller uses the amount of refrigerators in a certain state when calculating epsilon, however the measured number of refrigerators in this state and the actual number might not be the same due to packet loss. Thus the  $\tilde{N}_k^{on}$  or  $\tilde{N}_k^{off}$  should be modified to account for packet loss. This leads to a new calculation of  $\epsilon$ , being:

$$\epsilon_k = \begin{cases} \frac{(r_k - z_k)}{\tilde{N}_k^{off} \cdot \frac{N}{\hat{N}_{received}} \cdot \bar{p}}, & \text{for } r_k > z_k \\ \frac{(r_k - z_k)}{\tilde{N}_k^{on} \cdot \frac{N}{\hat{N}_{received}} \cdot \bar{p}}, & \text{for } r_k < z_k. \end{cases} \quad (\text{A.6})$$

This means that there are two kinds of adaptation of the controller, one which scales  $\epsilon$  with the estimated packet loss, and one which corrects the counted amount of *on* or *off* state refrigerators based on estimation of missing responses. Later we refer to these two types of adaptations to a) upstream adaptation and b) downstream adaptation, representing the direction of in-

## 5. Simulation methodology

formation flow, respectively. Using both adaptations the  $\epsilon$  formula becomes:

$$\epsilon'_k = \begin{cases} \frac{(r_k - z_k)}{\bar{N}_k^{off} \cdot \frac{N}{\bar{N}_{received}} \cdot \bar{p}} \cdot \frac{1}{1 - P_l}, & \text{for } r_k > z_k \\ \frac{(r_k - z_k)}{\bar{N}_k^{on} \cdot \frac{N}{\bar{N}_{received}} \cdot \bar{p}} \cdot \frac{1}{1 - P_l}, & \text{for } r_k < z_k. \end{cases} \quad (\text{A.7})$$

## 5 Simulation methodology

In order to evaluate the adaptation approach described in section 3.2 an example scenario has been implemented in a simulation framework. A framework for combined simulation of the control method and of the network behavior is developed for that purpose. We used MATLAB and OMNeT++ in our work, but conceptually, the procedure would be similar using other tools, it would probably require extensive changes to the framework. MATLAB is used to simulate the LV grid controller, and will therefore be considered the control simulator for the purpose of this paper.

Since the two tools, MATLAB and OMNeT++, are working with different time concepts, we need to ensure that the two tools interoperate properly in order to produce useful results. Coupling the operation between MATLAB and OMNeT++ is nothing new, as for example illustrated in Ref. [13] where it is used to model indoor wireless networks, and for that reason we will not go into detail regarding this coupling. Figure A.6 shows the workflow of the two simulators for a single control loop.

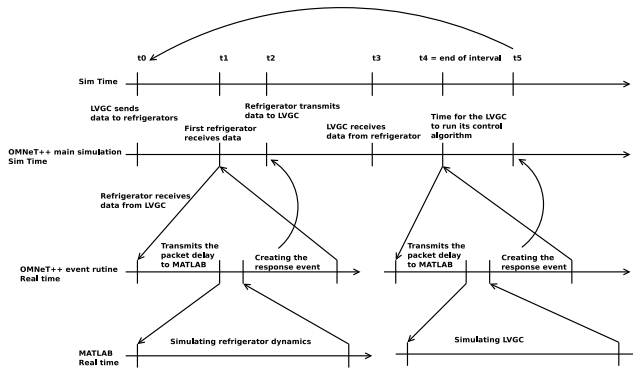

Fig. A.6: Message sequence diagram of an low voltage grid controller (LVGC) communicating with a single refrigerator.

OMNeT++ is handling the time of the simulation, and sends messages to MATLAB at the points where system dynamics and control actions need to be processed. To simulate the transport over the communication network, OMNeT++ requires information from MATLAB regarding the amount of data to

send, but it does not require actual packet content, this content must therefore be handled internally in MATLAB. Once a packet reaches the destination in the OMNeT++ simulation, the simulation time is paused and MATLAB is given information on the specific receiver entity of the packet. The execution flow now moves into MATLAB, which performs the required processing and returns control to OMNeT++ when done. The simulation time in OMNeT++ is then updated with an added processing delay. The control program can be triggered from OMNeT++ by communication network events such as the arrival of a packet, or by clock events, as is the case of the main control loop.

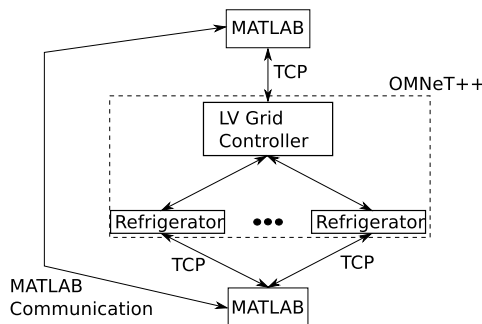

Fig. A.7: Interfaces between OMNeT++ and MATLAB.

It was chosen to have OMNeT++ initiate and handle the communication with MATLAB, and not the other way around, because it also handles simulation time. This means that OMNeT++ must know the time it takes for each control part to be processed. This process is illustrated in Fig. A.6. The structure of the communication between MATLAB and OMNeT++ is shown on Figure A.7.

## 6 Evaluation of the network aware control system

In this section we provide an overview of the results we obtained and discuss them in relation to the framework we setup.

### 6.1 Performance metric definition

The key performance metric of the control algorithm is defined as the error between the total consumed power and the power reference. This error to some degree reflects the effort, that the MV grid controller has to do in terms of extra effort of providing or distributing excess power over time. The parameter is calculated as

$$Err_p(k) = |r_k - z_k| \quad (\text{A.8})$$

## 6. Evaluation of the network aware control system

Summing up over time, and averaging, gives an indication of the energy demand for the particular LV grid domain over a time period.

$$Err_e(K) = \frac{1}{K} \sum_{k=0}^K |r_k - z_k| \quad (\text{A.9})$$

### 6.2 Base scenario

In the base case scenario, we make a simulation run of the control simulation without any influence of the communication network.

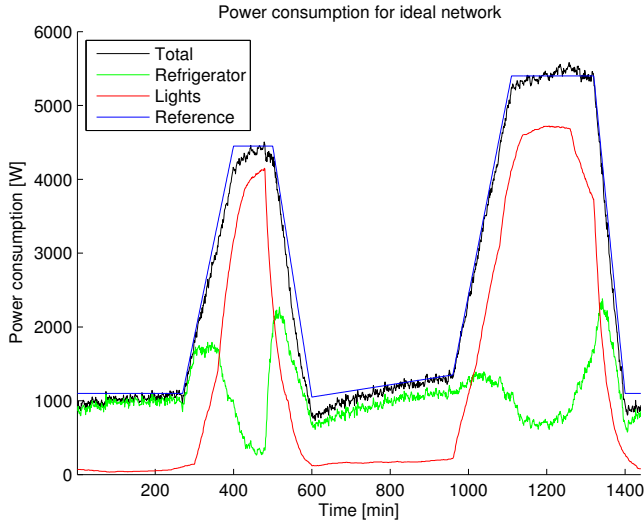

Fig. A.8: Base case simulation of the controller under ideal network conditions.

Figure A.8 illustrates clearly the role of the controller, namely to store energy in the refrigerators as before a power peak arises. It is seen by the initial rise of power consumption by the refrigerators, which during the peak load period is reduced. After the peak load period the refrigerator power consumption increases significantly to recover from the energy drain in the thermal energy ‘bank’. The cycle repeats itself for the late afternoon peak, however, not without violating the setpoint for which the controller was supposed to keep. This is a result of the stochastic elements. Any deviation from the reference relates to cases where power must be either taken from or input to the LV grid with the interaction of the MV grid controller.

Investigating the control scenario with lossy and delayed communication is now used to analyze 1) the impact of imperfect communication networks on top of the control system, and 2) how well this can be remedied by our

proposed solution of manipulating the control and feedback signaling without the knowledge of the controller to make up for packet losses.

### 6.3 Evaluation of the communication network influence and proposed solution

Five different simulations have been done, one with perfect communication network conditions, which will serve as the best achievable performance (lowest error), and the four combinations of with and without upstream and downstream adaptation. Where the one without any adaptation will show how the controller performs under imperfect communication network conditions, and the rest will show the effect of the adaptations. 15 days have been simulated for each simulation and the error is calculated for each minute. The average error was then calculated for each minute of the day. Due to significant fluctuations in this plot it was difficult to see any differences between the schemes. To show the trends in the error it was chosen to make a moving average of the error with a window size of 50 minutes, which can be seen in Figure A.9.

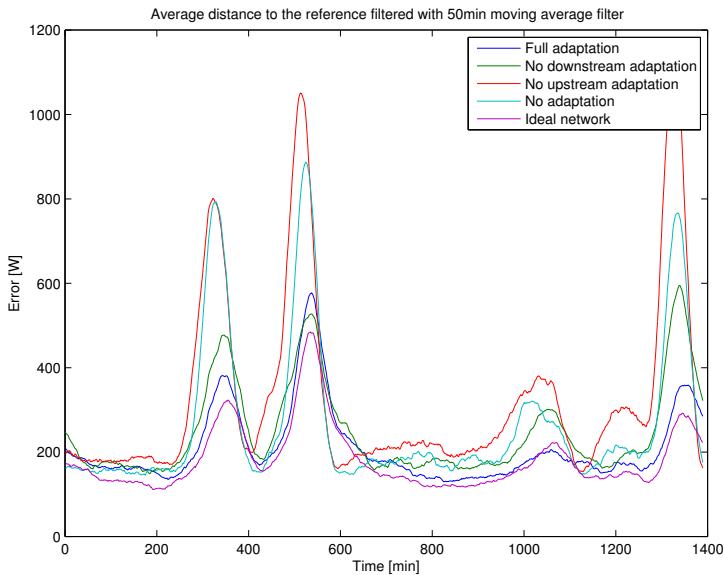

Fig. A.9: Moving average of the error with a window size of 50 minutes.

The results in Figure A.9 shows first a substantial impact due to the communication network imperfections (teal curve) and secondly that the proposed adaptations (blue curve) are effective. The error in terms of energy losses, becomes worse with the communication network degradation and if

## 7. Conclusion and future work

nothing is done, this may have impact on the overall strategy of which the MV controller needs to take if multiple LV grids should be considered within one MV control domain.

The average error over an entire day has been calculated for each scheme, by taking the average error for each day, and afterwards averaging this over the 15 simulated days. The standard deviations of the error have been calculated likewise.

<b>Adaptation</b>	<b>Mean error</b>	<b>95 % Confidence interval</b>
Ideal network	184,01	171,88 - 196,14
No adaptation	263,28	249,19 - 277,36
No upstream adaptation	324,19	314,91 - 334,12
No downstream adaptation	249,75	234,91 - 264,59
Full adaptation	211,42	200,91 - 221,92

**Table A.2:** Performance of the different schemes.

It is seen in Table A.2, that the imperfect communication network conditions have impact on the controller performance. It is also seen that only adapting for downstream imperfections will cause the controller to be over aggressive, and an increased error is experienced. It can also be seen that only adapting for downstream imperfections reduces the performance significantly. If we consider the calculation of  $\epsilon$  as shown in equation (A.7), we see that if there is no modification of the received responses (no upstream adaptation),  $\epsilon$  will increase, making the controller more aggressive. Furthermore if  $\epsilon$  is adapted based on the packet loss it becomes even larger, thus even more aggressive. This leads to the controller becoming overly aggressive leading to poor performance. The performance can be increased significantly by adapting for upstream imperfections, and even more by adapting for both upstream and downstream imperfections, leading to a total improvement of around 20 %.

## 7 Conclusion and future work

We introduce an approach to take measured communication network performance into account via parameter adaptation in middleware functions and show the effectiveness in simulation experiments. We also show that including communication network considerations when designing systems, like smart grids, where faults can be very expensive, is important. We propose a solution for this inclusion, where control signals are adapted according to communication network QoS measurements, and evaluate this in a LV smart grid control scenario using simulations. This can in principle be realized via a middleware solution as sketched here; however the detailed design

in order to allow the middleware to act transparently to the control algorithm is not given in this paper.

We show that by adapting the controller to current communication network QoS estimations, the controller performance can be increased significantly (as seen when using full adaptation). It can, however, also be concluded that adapting the controller to the communication network can in some cases decrease control performance, if the controller becomes over aggressive (as seen when only considering downstream adaptations).

This paper shows how packet loss probabilities can be effectively included to increase control performance, however, further explorations into the inclusion of other QoS parameters such as latency and throughput can prove useful.

## Acknowledgment

The authors would like to thank Tatiana Kozlova Madsen for help with the development of a suitable simulation platform and Kartheepan Balachandran for help with data processing and useful discussions. The research leading to these results has received funding from the European Community's Seventh Framework Programme (FP7/2007-2013) under grant agreement N°318023 for the SmartC<sup>2</sup>Net Project and from the Danish Research Council for the project EDGE. Further information regarding SmartC<sup>2</sup>Net is available at [www.SmartC2Net.eu](http://www.SmartC2Net.eu).

The Telecommunications Research Center Vienna (FTW) is supported by the Austrian Government and by the City of Vienna within the competence center program COMET.

## References

- [1] E. styrelsen, "Energistatistik 2010," 2010, ISBN: 978-87-7844-908-5.
- [2] Y. Yan, Y. Qian, H. Sharif, and D. Tipper, "A survey on smart grid communication infrastructures: Motivations, requirements and challenges," *Communications Surveys Tutorials, IEEE*, vol. 15, no. 1, pp. 5–20, 2013.
- [3] S. Consortium, "Fp7 smart control of energy distribution grids over heterogeneous communication networks project," 2013, <http://smarc2net.eu/>.
- [4] V. Gungor, D. Sahin, T. Kocak, S. Ergut, C. Buccella, C. Cecati, and G. Hancke, "Smart grid technologies: Communication technologies and standards," *Industrial Informatics, IEEE Transactions on*, vol. 7, no. 4, pp. 529–539, 2011.



## References

- [5] F. Aalamifar, H. Hassanein, and G. Takahara, "Viability of powerline communication for the smart grid," in *Communications (QBSC), 2012 26th Biennial Symposium on*, 2012, pp. 19–23.
- [6] M. Korke, N. Hosseinzadeh, and T. Moazzeni, "Performance evaluation of a narrowband power line communication for smart grid with noise reduction technique," *Consumer Electronics, IEEE Transactions on*, vol. 57, no. 4, pp. 1598–1606, 2011.
- [7] J. Colandairaj, G. Irwin, and W. G. Scanlon, "Wireless networked control systems with qos-based sampling," *Control Theory Applications, IET*, vol. 1, no. 1, pp. 430–438, 2007.
- [8] M. Pohjola, "Adaptive control speed based on network quality of service," in *Control and Automation, 2009. MED '09. 17th Mediterranean Conference on*, 2009, pp. 784–789.
- [9] D. Niyato, P. Wang, Z. Han, and E. Hossain, "Impact of packet loss on power demand estimation and power supply cost in smart grid," in *Wireless Communications and Networking Conference (WCNC), 2011 IEEE*, March 2011, pp. 2024–2029.
- [10] S. Consortium, "Smartc2net deliverable d1.1: Smartc2net use cases, preliminary architecture and business drivers," 2013, <http://smarc2net.eu/>.
- [11] M. Petersen, K. Edlund, L. Hansen, J. Bendtsen, and J. Stoustrup, "A taxonomy for modeling flexibility and a computationally efficient algorithm for dispatch in smart grids," in *American Control Conference (ACC), 2013*, June 2013, pp. 1150–1156.
- [12] L. Totu, J. Leth, and R. Wisniewski, "Control for large scale demand response of thermostatic loads," *American Control Conference*, June 2013.
- [13] Z. Zhang, Z. Lu, Q. Chen, X. Yan, and L.-R. Zheng, "Cosmo: Co-simulation with matlab and omnet++ for indoor wireless networks," in *Global Telecommunications Conference (GLOBECOM 2010), 2010 IEEE*, 2010, pp. 1–6.

## References

# Paper B

## Smart Grid Control and Communication: the SmartC2net Real-Time HIL Approach

Catalin-Iosif Ciontea, Rasmus Pedersen, Thomas le Fevre  
Kristensen, Christoffer Eg Sloth, Rasmus Løvenstein Olsen,  
Florin Iov

The paper has been published in the  
*PowerTech, 2015 IEEE Eindhoven* pp. 1-6.

© 2015 IEEE

*The layout has been revised.*

## Abstract

*The expected growth in distributed generation will significantly affect the operation and control of today's distribution grids. Being confronted with fast fluctuating power from distributed generations, the assurance of a reliable service (grid stability, avoidance of energy losses) and the quality of the power may become costly. In this light, Smart Grids may provide an answer towards a more active and efficient electrical network. The EU project SmartC2Net aims to enable smart grid operations over imperfect, heterogeneous general purpose networks, which poses a significant challenge to the reliability due to the stochastic behaviour found in such networks. Therefore, key concepts are presented in this paper targeting the support of proper smart grid control in these network environments and its Real-Time Hardware-In-the Loop (HIL) verification. An overview on the required Information and Communication Technology (ICT) architecture and its functionality is provided and a description of a relevant use case that deals with voltage control on medium and low voltage networks along its evaluation approach on an experimental test bed is detailed.*

## 1 Introduction

Campaigns from Europe's national governments promoting green energy have led to an increased penetration of distributed Photovoltaic (PV) systems in households, especially in Germany and Southern Europe. Installation of small household wind turbines, newly supported in Denmark for example, will further increase the amount of fluctuating power in distribution grids. All these dispersed generation units can introduce power quality issues as well as bottlenecks and congestion. For example, some of the Danish Distribution System Operators (DSOs) have encountered problems with voltage profiles in feeders with high penetration of household PV installations. By adding more fluctuating power from small wind turbines, the present problems, i.e. poor voltage and power quality, will worsen, eventually triggering the disconnection of loads or entire parts of the distribution grid. In some cases power quality issues might be solved by curtailment of power. However, this can result in energy systems devoid from clean and renewable energy sources. Typically, DSOs monitor the Medium Voltage (MV) feeders and maintain admissible voltage levels in these feeders by means of On-Load Tap-Changers (OLTC) installed in primary substations (High Voltage to Medium Voltage). Thus, voltage on a substation's MV side is shifted upwards or downwards in small steps according to measurements at critical points. However, this control is not able to run smoothly and very often as required by the intermittent fluctuating renewable sources. Capacitor banks, also installed in primary substations, may contribute with an additional reactive power injection, hence boosting the voltage in MV feeders. However, fast

## 1. Introduction

transients are introduced into the grid when switching the capacitor banks on and off. Moreover, there are limitations regarding the number and the frequency of this switching imposed by technical requirements. Notwithstanding, all these control capabilities are not designed to cope with fluctuating renewable energy. The situation is more critical in secondary substations (MV to LV) where all the small dispersed generation units at household level are actually being installed. The DSOs are currently not automatically controlling the voltage profiles in these Low Voltage (LV) grids. In some cases they might only have some limited information regarding the load of these substations. Currently, renewable energy systems like small wind turbines and solar PVs are capable of providing smooth control of reactive power. However, this capability is not used in a coordinated manner by DSOs. The SmartC2Net project strives to activate these capabilities and to provide DSOs with more and better control options for heterogeneous communication networks. To ensure a reliable operation of the electrical grid with high penetration of renewable in MV/LV side while using heterogeneous networks, the SmartC2Net employs a concept of two interacting control loops [1] and [2]. As shown by Figure 1, the inner communication control loop deals with the intricacies of managing networks and their related protocols. It is thus in charge of handling the smart grid control messages, which are issued by the outer energy control loop. The energy control algorithms of this outer loop work on input data collected from the grid's energy sensors and send their results back to the appropriate actors via the respective communication networks. The interaction of loops, energy as well as ICT control, is a critical part of the project as it enables their coordinated operation to achieve the desired adaptability and robustness of the Smart Grid even in the presence of faults in communication network and cyber-attacks [1], [3] and [4].

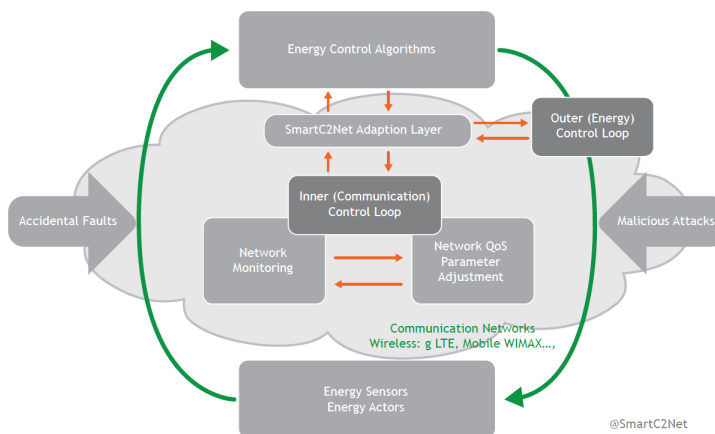

Fig. B.1: SmartC2Net Concept of Interacting Energy and ICT Control Loop [1].

The outer energy control loop performs monitoring and control tasks for the numerous distributed components of the grid. It therefore needs a means for communication enabling the reception of sensor data from field devices, as well as the transmission of control signals. Due to the different locations of grid devices, varying communication infrastructures are in place for delivering data with given protocols. As reliability is of paramount importance, the overall system needs to maintain a high level of service quality in cases of poor network performance, partial or even complete failures and cyber-attacks. In order to demonstrate and evaluate the developed ICT platform's capabilities to operate safely under challenging conditions, several real-world use cases are in focus of the SmartC2Net project [1]- [2]. Communication infrastructure solutions and middleware have become of interest in supporting such smart grids [2]. Here SmartC2Net project takes into account a unique and tight interaction between the two loops and a close link to evaluation in a Real- Time realistic setup described in this paper.

## 2 Use Cases

The following four use cases are considered in the SmartC2net project [5]:

- Medium Voltage Control (MVC): focusing on medium voltage control under cyber-attacks.
- External Generation Sites (EGS): focusing on meeting demand and responses at medium and low voltage grids in different communication network conditions and technologies.
- Electrical Vehicle Charging (EV): focused around scheduling and planning the charging process of electrical vehicles in low voltage grids and at charging stations attached to the medium voltage grid.
- Customer Energy Management Systems (CEMS) and Automated Meter Reading (AMR): focusing on the integration of devices on customer sites.

The project's second use case, External Generation Site, is concerned with decentralized energy storage and generation, aspects of Smart Grids that experience a steady rise in deployment and thus importance [5]. Despite being primarily tasked with the control of low voltage grid entities, this use case also incorporates interfaces to mid and high voltage grid parts like secondary and primary substations. The reasoning behind this can be found in the benefits substation controllers might extract from an ability to communicate with

### 3. Control Architecture

external generation sites. Examples of such profitable information exchanges are the ability to pass the flexibility aggregated on the low voltage level on to MVC, as well as the optimization of energy costs, losses and low voltage profiles. Such functionalities depend on reliable information flows between the respective devices and are therefore enabled by resilient ICT infrastructures [3]- [6].

## 3 Control Architecture

This section presents the architecture of the control system, and puts an emphasis on the choices taken to improve the resilience of the control system towards communication faults. The described control system only includes the low and medium voltage levels, however the complete architecture targeted in SmartC2net project can be found in [6].

### 3.1 Hierarchical Control Structure

A typical distribution grid operated by a DSO comprises of hundreds of primary substations and thousands of secondary substations each of these having hundreds of consumers. Thus, measures must be taken when designing the control system to get a manageable and controllable system. It is decided to adopt a hierarchical control structure for the targeted smart grid control applications. Figure 2 shows this control structure mainly consisting of two layers: Medium Voltage Level and Low Voltage Level. On each layer there is an associated controller and a collection of assets.

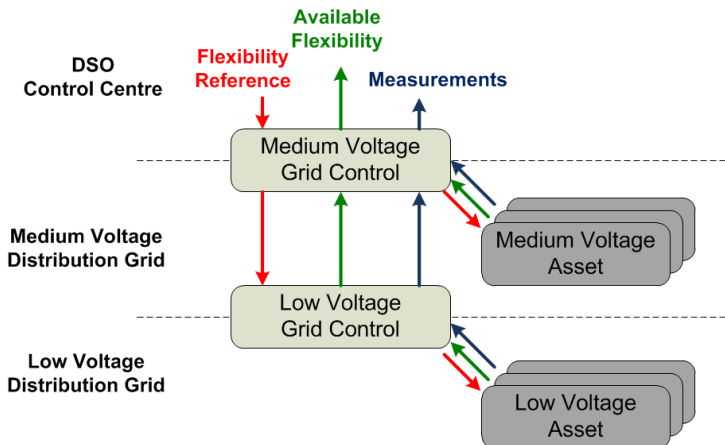

Fig. B.2: Hierarchical structure of the control system.

In terms of interfaces, the Medium Voltage Grid Controller (MVGC) receives a power set point from a higher hierarchical layer that is not in scope of the present work described in this paper, and sends back measurements of grid variables and available flexibility. The MVGC then controls its assets according to the received set-point. It is worth to notice that the Low Voltage Grid Controller (LVGC) in this setup also acts as a flexible asset for the MVGC. Similarly, the LVGC controls its assets according to the set-point received from the MVGC, and sends back information on e.g. flexibility to the MVGC.

### **3.2 Control Functionalities and Requirements**

The considered control system has two overall functionalities namely i) Tracking of power reference and ii) Voltage control.

The two functionalities are decoupled to allow different actors to operate them, as both functionalities may be relevant for DSO, while tracking of power reference may be relevant for an aggregation unit [7].

Finally, the control system must obey the physical constraints on e.g. cables in the grid in addition to regulatory constraints on the voltage magnitudes, which are specified in terms of 10 minutes mean values on each bus bar of the system [8].

### **3.3 Controllers**

This section gives an overall description of the low and medium voltage controllers.

#### **Low Voltage Grid Controller**

The low voltage grid controller manages the usage of assets in the low voltage grid. These assets comprise batteries, PVs, EVs, and flexible households. Thus, the flexibility of the majority of these assets is stochastic. Furthermore, the communication between assets and controller is subject to delay and packet loss. To handle the variability in the number of available assets, the control system varies the set-points to the available assets such that the same dynamic behaviour is obtained irrespectively of the number of assets available, if this is possible within the constraints of the system. To handle the delay imposed by the communication, which may cause instability, the control system adapts its gains according to the delay, by decreasing the gain when the delay is increased. The cost of this is reduced bandwidth of the control system.



### Medium Voltage Grid Controller

In this section an overview of the control system for energy balancing and loss minimization in the medium voltage grid is given. The controlled system consists of the electrical grid, flexible assets, e.g. wind and solar photovoltaics, and non-flexible loads. The control system structure is depicted in Figure 3.

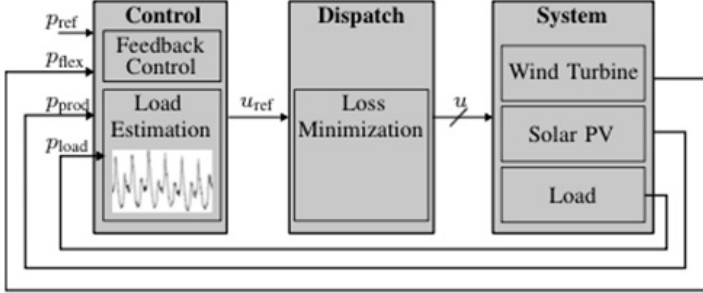

Fig. B.3: Control system structure.

It is seen from Figure 3 that this controller implements the functionalities energy balancing to follow the set-point  $P_{ref}$  and loss minimization via a particular dispatch strategy. Note that the method is not limited to this particular set of assets, i.e., other assets may easily be added to the system. Based on estimation of inflexible load and the power reference signal  $p_{ref}$ , the feedback controller calculates a reference  $u_{ref}$ , which is dispatched to the flexible production units. Further, the medium voltage grid controller sees the low voltage grid controller as a flexible asset.

To estimate the non-flexible loads a linear model based on harmonic oscillators is used in combination with a Kalman filter. The result of applying this approach to 14 days of real residential consumption data is depicted in Figure 4.

The control signal,  $u_{ref}$ , produced by the control system detailed above, can be passed through a dispatch algorithm. The objective of the dispatch algorithm is to minimize active power loss while respecting asset constraints. By applying assumptions of no voltage issues, availability of voltage measurements, and estimation of active and reactive power at inflexible busses, the loss minimization problem can be shown to be convex. Thereby, it can be solved globally with known methods.

The voltage control functionality is based on safety verification techniques. It is said that a system is safe if it does not violate any constraints, and apply the barrier certificate method for proving the safety of this system [9]. This approach is illustrated through the simulation example shown in Figure 5

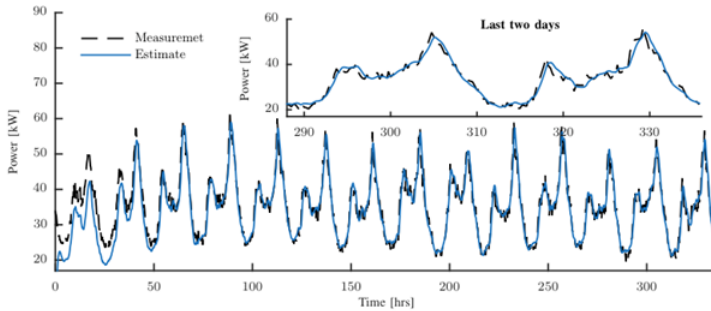

**Fig. B.4:** Performance of proposed estimation method throughout a 14-day period, evaluated on real consumption data.

where the system clearly violates the voltage constraints if no curtailment algorithm is applied. This method not only guarantees that the constraints are not violated, but also at what voltage level it should be applied. It should be noted that this functionality can be applied on both a medium voltage and low voltage level.

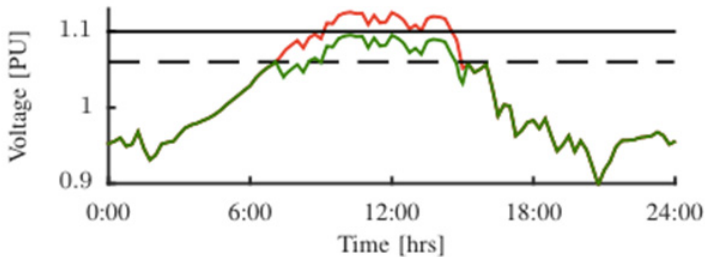

**Fig. B.5:** Voltage magnitude at the most critical bus, without any curtailment (red), and with curtailment (green). Curtailment is initiated when the voltage crosses the black dashed line.

## 4 Real-Time HIL Setup

The second Use Case EGS in SmartC2net project as well as the control strategy presented above is supported by a Real-Time HIL setup that is developed at Aalborg University, Denmark [10].

The system comprise of several key elements as:

- **Real-Time Power System Emulator.** This system comprises of two elements namely the Real-Time Digital Simulator and the Power Linear Amplifier. The Real-Time Digital Simulator based on Opal-RT is implementing a large scale energy network including systems using the

#### 4. Real-Time HIL Setup

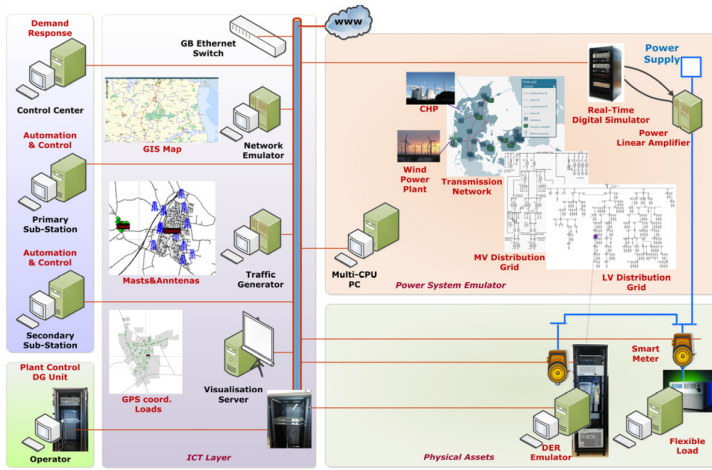

Fig. B.6: Architecture of Real-Time HIL setup [10].

multidomain physics approach. This means that not only the electrical network and system is captured but also other systems such as thermal, mechanical, etc. The main goal for this Real-Time simulator is to capture the electrical system from the transmission level (TSO) down to low voltage distribution grids (DSO) as well as the district heating networks. Other energy systems such as gas networks and transportation systems can also be represented. The Opal-RT is able to simulate up to 20000 three-phase buses in RMS and 600 nodes EMT. Implementation of all models is based on MATLAB/Simulink. The 3-phase voltages measured in a given point in the distribution network are applied to the 50 kVA AC/DC fully regenerative Power Linear Amplifier that is supplying the physical components i.e. Dispersed Energy Resource, Flexible Load as they are part of the larger system. The three phase currents are fed in back to the Real-Time Digital Simulator.

- Dispersed Energy Resource.** A fully regenerative four quadrant power converter is emulating the dispersed generation unit. It has  $\pm 20\text{kW}/\pm 10\text{kVAR}$  capability and it is used to mimic characteristics of a small wind turbine, a PV systems or energy storage. Implementation of models as well as controls is done using MATLAB/Simulink on a dSpace 1103 system. This emulator is controllable remotely via the internal high-speed communication network.
- Flexible Load.** A 4.5 kW Controllable AC/DC Load is used to mimic

the behaviour of loads in a typical household. Implementation of models as well as controls is done using MATLAB/Simulink. This system is receiving set-points from hierarchical control structure.

- **Internal High-Speed Communication Network.** It is the ICT backbone for the setup and aims to emulate different technologies and topologies for the communication networks. A dedicated server is used to mimic the characteristics of different communication networks such as 3G, LTE, xDSL etc, for which all traffic between controllers and assets are routed through. A dedicated server is used for generating stochastic or trace-based background traffic patterns to emulate realistic cross traffic. This traffic is based on traffic models and traces of real network traffic. The network configuration includes mapping GIS data to communication network as well as Offline and Online network reconfiguration is done from a Visualization server. It is the purpose of the SmartC2Net project to develop an ICT platform that manipulates with the data access strategies in between entities (controllers and assets) to overcome potential issues in the network affecting the end to end QoS.
- **Control Layers.** A dedicated platform for demand response is used to host functionalities related to aggregation and control of large scale flexible loads in distribution networks. A dedicated industrial controller (Medium Voltage Grid Controller) is used to host typical control functions in primary substations in medium voltage grids. It is also offering the possibility to implement and verify new control and operational strategies for components in medium voltage networks such as voltage control, loss minimization, etc. This industrial controller is getting information from the downstream assets placed in medium and low voltage networks as highlighted in the next sections of this paper. A dedicated industrial controller (Low Voltage Grid Controller) is used to host new control functionalities in secondary substations. This platform offers the possibility to implement and verify new control and operational strategies for flexible assets in low voltage networks such as voltage control along the low voltage feeders, aggregation of data from smart meters, etc. Another industrial controller is hosting typical control functionalities implemented in renewable based generation plants such as wind or PV. Implementation of controls in all platforms is done using MATLAB/Simulink.
- **Smart Meters.** Different smart meter technologies are providing power and energy consumption from the physical assets to the upper hierar-

chical control levels.

New components/actors can be easily added to this system.

# 5 Experimental Results

## 5.1 Distribution Grid

A realistic medium voltage distribution grid with seven busses; two load busses, two production busses, and one bus managed by a local low voltage grid controller (LVGC) is considered to demonstrate the control strategy presented in Section III. The two non-controllable loads are aggregated residential loads and the two production units are a wind power plant (WPP) and a solar power plant (SPP). Realistic wind and irradiation profiles based on measured data are used for the system. The LVGC is managing a 41 bus residential grid with seven PV systems (yellow boxes), and three flexible assets (green boxes). The flexible assets are capable of both producing and consuming active and reactive power. This setup is depicted in Figure 7 and Figure 8. The medium voltage grid controller (MVGC) receives measurements from the non-controllable loads as provided by Smart Meters, and information on current state and flexibility from the three assets (the MVGC sees the LVGC as a flexible asset). Based on an active power reference received from the upper layer and the aforementioned information, the MVGC distributes reference signals to the assets. The LVGC receives the reference signal from the MVGC and based on flexibility information on the low voltage level, distributes references signals to the three fully controllable assets.

All data traffic is routed through the network emulator and traffic generator servers. Packet loss and communication delays are obtained from real GPRS measurements and mapped on GIS data.

## 5.2 Simulation Results

The active power reference signal received by the MVGC has arbitrarily been chosen to illustrate the hierarchical control systems ability to follow a power reference. During six hours the reference is set to zero, which means that there is no import or export from the high voltage grid and the entire MV/LV grid runs based on its own generation facilities.

The MVGC and LVGC's tracking ability is shown in Figure 9. The oscillations when a step in the reference is applied are caused by the communication delays present between the low voltage grid assets and LVGC. At 10:00 in the morning, the LVGC gains are adapted to handle the communication delays.

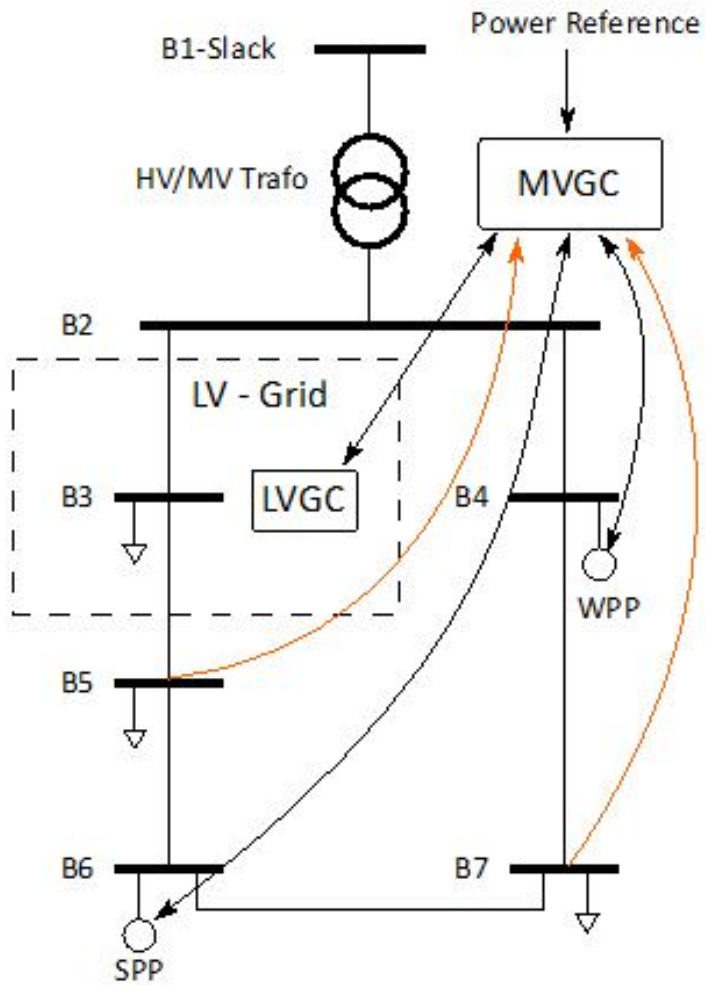

Fig. B.7: Layout of Medium Voltage Grid.

## 5. Experimental Results

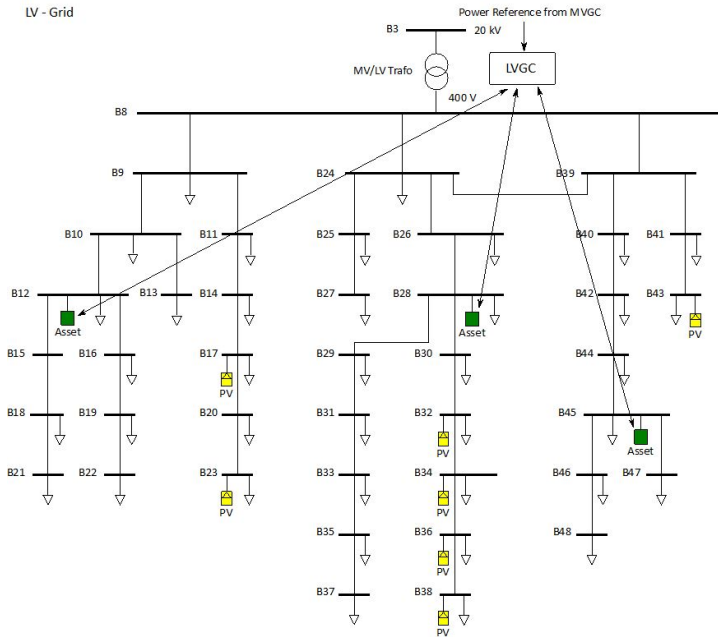

Fig. B.8: Structure of Low Voltage Grid.

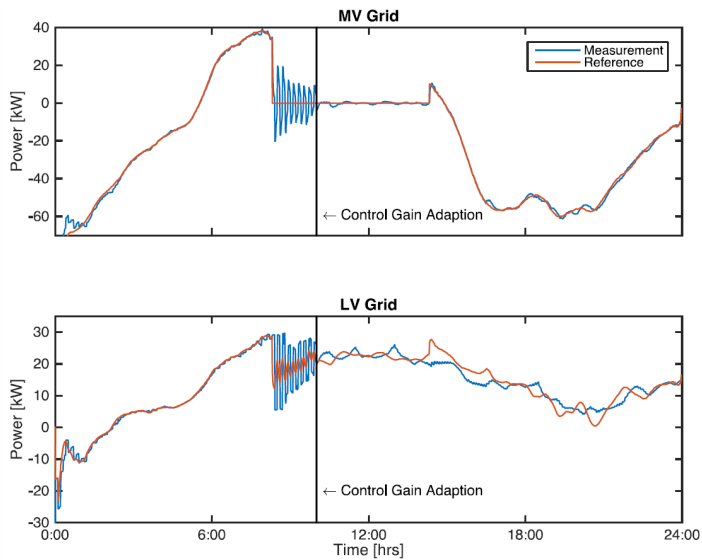
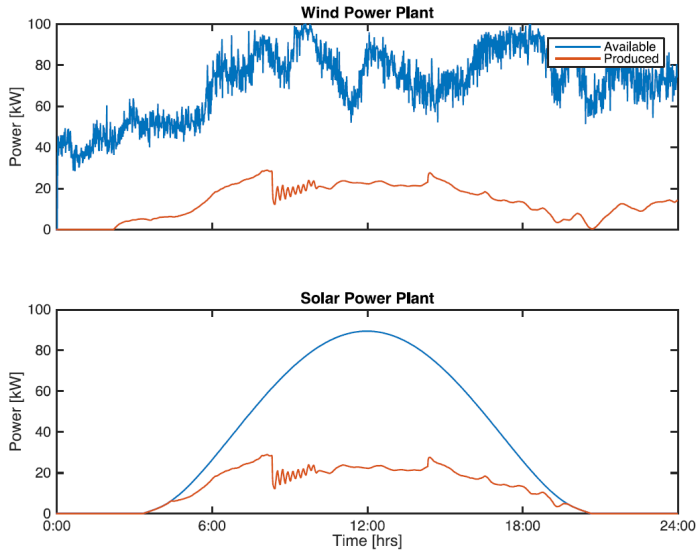

Fig. B.9: Tracking capability of the medium voltage grid controller (Top), and low voltage grid controller (bottom). Positive values indicate export and negative import of power.

The active power production of the SPP and WPP is illustrated in Figure 10 for the entire considered day.



**Fig. B.10:** Production profiles of the wind power plant (Top), and the solar power plant (bottom).

Further, the active power injection/consumption of the low voltage grid assets is illustrated in Figure 11.

### 5.3 Discussion of Simulation Results

A number of interesting outcomes can be highlighted from the simulation results shown above. First, it is possible for both the MVGC and the LVGC to follow the references received closely up until the step in reference, which indicates that via the hierarchical control structure it is possible for a distribution grid to offer services to upper hierarchical control layers. Secondly, when the step in reference occurs the measured power begins to oscillate heavily. This is caused by delay and loss in information between the LVGC and assets. However, when the control gains in the LVGC are adapted to handle the delay and loss, the oscillations settle and the system again follows the reference closely. The adaption in gain eliminates the oscillations but also decreases the reference following capability of the LVGC; which is expected as the bandwidth of the controller is decreased. This clearly illustrates the trade-off between robustness and performance in control. Moreover, the link between the communication network monitoring and the control algorithms is obvious, as the monitoring framework can deliver information of communication network state, to the controllers.



## 5. Experimental Results

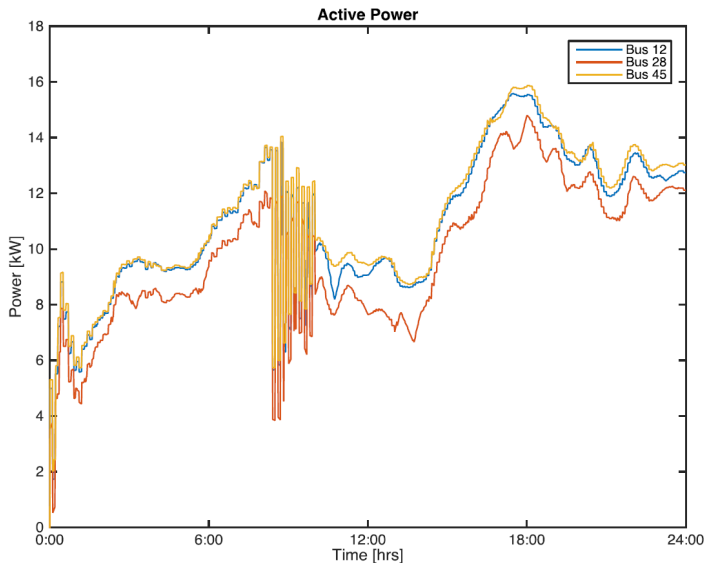

**Fig. B.11:** Power production from low voltage grid assets.

In this paper some of the key concepts of the EU FP7 project SmartC2Net are presented targeting the support of advanced smart grid controls when taking into account the communication networks. An overview on the required ICT architecture and its functionality is provided and a brief description of the External Generation Site use case including control architectures is given. A key element in any smart grid applications is the evaluation and assessment of the developed solution accounting for real-time behaviour of the three main domains involved namely electrical grid, control layers and communication infrastructure. This paper is proposing a Real-Time HIL approach where all these elements are captured in a test bed. By doing this new Smart Grid control algorithms can be easily evaluated in a realistic manner and thus provide valuable information regarding boundaries of current communication technologies for specific control functionalities. Thus, the time-to-market can easily be reduced for advanced large scale Smart Grid controls.

## Acknowledgment

The authors acknowledge the financial support from the European Community's Seventh Framework Programme (FP7/20072013) under grant agreement no. 318023.

## References

- [1] S. Consortium, "Fp7 smart control of energy distribution grids over heterogeneous communication networks project," 2013, <http://smarc2net.eu/>.
- [2] R. L. Olsen, F. Iov, C. Hägerling, and C. Wietfeld, "Smart control of energy distribution grids over heterogeneous communication networks," in *2014 4th International Conference on Wireless Communications, Vehicular Technology, Information Theory and Aerospace Electronic Systems (VITAE)*, May 2014, pp. 1–5.
- [3] S. Consortium, "Grid and network monitoring architecture and components, fault management approach," 2013, <http://smarc2net.eu/public-deliverables/>.
- [4] —, "Preliminary smarc2net communication architecture and interfaces," 2013, <http://smarc2net.eu/public-deliverables/>.
- [5] —, "Smarc2net deliverable d1.1: Smarc2net use cases, preliminary architecture and business drivers," 2013, <http://smarc2net.eu/>.
- [6] —, "Control framework and models," 2015, <http://smarc2net.eu/public-deliverables/>.
- [7] E. D. S. O. for Smart Grids, *Flexibility: The role of DSOs in tomorrow's electricity market*, 2014.
- [8] EN50160:2010, *Voltage characteristics of electricity supplied by public electricity networks*.
- [9] S. Prajna, A. Jadbabaie, and G. J. Pappas, "A framework for worst-case and stochastic safety verification using barrier certificates," *IEEE Transactions on Automatic Control*, vol. 52, no. 8, pp. 1415–1428, Aug 2007.
- [10] F. Iov, *Smart Energy Systems Lab*, [www.smart-energy-systems-lab.et.aau.dk](http://www.smart-energy-systems-lab.et.aau.dk).

# Paper C

## On-line Configuration of Network Emulator for Intelligent Energy System Testbed Applications

Mohammed Kemal, Thomas le Fevre Kristensen, Rasmus  
Løvenstein Olsen, Christos Apostolopoulos

The paper has been published in the  
*AFRICON 2015, Addis Ababa, 2015*, pp. 1-4.

© 2015 IEEE

*The layout has been revised.*

## Abstract

*Intelligent energy networks (or Smart Grids) provide efficient solutions for a grid integrated with near-real-time communication technologies between various grid assets in power generation, transmission and distribution systems. The design of a communication network associated with intelligent power system involves detailed analysis of its communication requirements, a proposal of the appropriate protocol architecture, the choice of appropriate communication technologies for each case study, and a means to support heterogeneous communication technology management system. This paper discusses a mechanism for on-line configuration and monitoring of heterogeneous communication technologies implemented at smart energy system testbed of Aalborg university. It proposes a model with three main components, a network emulator used to emulate the communication scenarios using KauNet, graphical user interface for visualizing, configuring and monitoring of the emulated scenarios and a network socket linking the graphic server and network emulation server on-line. Specifically, our focus area is to build a model that gives us ability to look at some of the challenges on implementing inter-operable and resilient Smart Grid networks and how the current state of the art communication technologies are employed for smart control of energy distribution grids.*

## 1 Introduction

In our current world with intelligent energy systems, coupling major energy generation sectors with renewable and non-renewable sources is considered as a key to promote clean energy and improve efficiency and costs. Various researches are being done for a cost-effective solution incorporating existing and future communication networks of both energy and telecommunication providers, enabling exchange of data among end-users, power generating facilities and operators, and offering open service platform for implementation of the advanced grid monitoring and control functionalities [1].

However, there is limited availability of smart energy installations or real-time systems to test the standards being developed, address the resulting issues and to justify worth of using the technology. Hence smart energy system testbed is built at Aalborg University as part of SmartC2Net EU project with the goal to develop, implement, and validate robust solutions that enable smart grid operation on top of heterogeneous communication infrastructures [2].

By taking use of the testbed, the main focus for this work is a mechanism that enables detailed analysis of communication QoS requirements, choice of appropriate communication technologies for specific use cases and integrating heterogeneous communication technologies for intelligent energy network emulation.

## 2 Related Works

In relation to designing heterogeneous communication network for smart grid implementation, [3] is focused on proposing a heterogeneous communication paradigm for smart grids based on power line communications and wireless networks. The proposal is related to the framework of the ITU (International Telecommunication Union) ubiquitous sensor network architecture using the ITU next-generation network model. The article argues that this architecture allows for better management of the QoS in the smart grid and should facilitate interoperability with other technologies.

[4] discusses some of the challenges and opportunities of communications research in the areas of smart grid and smart metering. In particular, focus is given on some of the key communications challenges for realizing inter-operable and future proof smart grid/metering networks, smart grid security and privacy, and how some of the existing networking technologies can be applied to energy management.

As for standards regarding QoS parameters, [5] states the communication delivery times for different applications in smart grids. It has described a standard defining communication delivery times of information to be exchanged within and external to substation integrated protection, control, and data acquisition systems [5]. Our paper here differs from other literature's because it proposes a method for on-line configuration of heterogeneous communication technologies for a test-bed implementation using KauNet.

## 3 Smart Energy Systems Laboratory

Smart energy system setup shown at Figure C.1 is a testbed built with the vision to capture key components and domains from energy markets down to individual smart assets in a real-time hardware in the loop framework and facilitate a platform to design, build and test the proposed new technologies [2].

It is of great aid for analysis of adaptive network and grid monitoring, strategies to control communication network configurations and QoS parameters, and extended information models and adaptive information management procedures. It is built to support three key sectors in intelligent power systems, the communication layer, control layer, and power system assets [6].

### 3.1 Communication Layer

The communication layer has traffic generator, network emulator and visualization server (shown at Figure C.1). The traffic generator is built with capabilities to support platforms such as Scapy and TCPRelay. The network

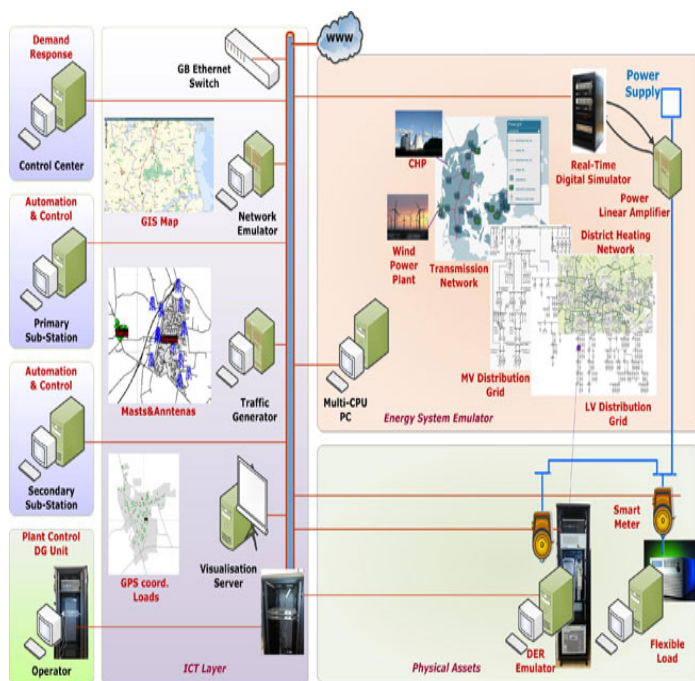

Fig. C.1: Overview architecture for Smart Energy Systems Laboratory Setup [2]

emulator is built to support state of the art network emulation and simulation tools like Dummynet, Kaunet, OMNeT++ and NS-3. For the system proposed here, KauNet is used to emulate and model the communication infrastructure.

#### **Kaunet Overview**

KauNet is an add-on to the well-known Dummynet network emulation software. KauNet extends Dummynet by providing deterministic emulation capabilities [7]. Hence, It enables a higher control of the emulated network. The major reason why KauNet is used for modeling the emulation system is because it provides capability to perform network modeling with large degree of control and repeatability. It allows deterministic placement of packet losses as well as more precise control over bandwidth and delay changes.

Patterns are used to provide advanced control of per-packet, or per-millisecond, control over the emulated network model. To create patterns, we can use three types of input mechanisms, by using input data from analytical expressions, from practical experimental tests and from simulated tests. For example, experimental test results for GPRS, LTE and ADSL communication technologies are built by using this model.

Currently, the following five types of patterns are supported by the model proposed here:

- packet loss patterns
- bit-error patterns
- bandwidth change patterns
- delay change patterns
- packet reordering patterns

### **3.2 Control Layers**

The model implemented in the control layer has components to model and analyze, demand response platform(DR), automation and control for primary and secondary sub-station, medium voltage grid controller, low voltage grid controller and power control for distributed generation unit. Implementation of models as well as controls is done using MATLAB/ SIMULINK [6]. This system is receiving set-points from hierarchical control structure.

### **3.3 Power System Assets**

The power system simulator is using real time energy system emulator where it consists of two elements namely the Real-Time Digital Simulator and Power

Linear Amplifier. The assets supported by the emulator are a generic dispersed energy resource with wind, PV and battery connected through Smart Meter, a flexible load where a 4.5 kW controllable AC/DC load is used to mimic the behavior of loads in a typical household.

### **3.4 Online Configuration of Network Emulator Overview**

The system is modeled with ability to visualize the whole communication system on-line where a graphic server is used to monitor and configure the telecommunication infrastructure modeled using the network emulator. It will help the emulation platform monitor the condition/impact of communication technologies used on our testbed. This model can be used to study the following three scenarios in detail.

#### **Homogeneous communication environment**

– One communication technology is used for the whole system. To give an example, all smart meters, data aggregators and controllers are connected using Ethernet technology. Such scenarios may be obtained in new and completely projected installations.

#### **Heterogeneous communication environment**

– The components on the power grid share a mix of different communication technologies. An example can be given where multiple smart meters via GPRS, other smart meters are utilizing LTE, Aggregators communicating using ADSL. This environment may be a case when a single communication technology cannot be deployed.

#### **Multiple communication-interface environment**

Each component may have the ability to use more than one communication technology using multiple interface. To give an example, a scenario can be considered where smart meter can choose between LTE and ADSL depending on the condition of the communication link.

## **4 System Model**

On-line configuration model implemented at smart energy systems testbed is depicted by Figure C.2. It incorporates the graphic server used as the graphical user interface in order to visualize, monitor and configure the emulated scenarios. The emulation server is set to emulate the communication infrastructure using KauNet on a pattern generated from real experimental tests.



## 4. System Model

The two systems are connected using UDP network sockets implemented on both the graphic server and the network emulation server.

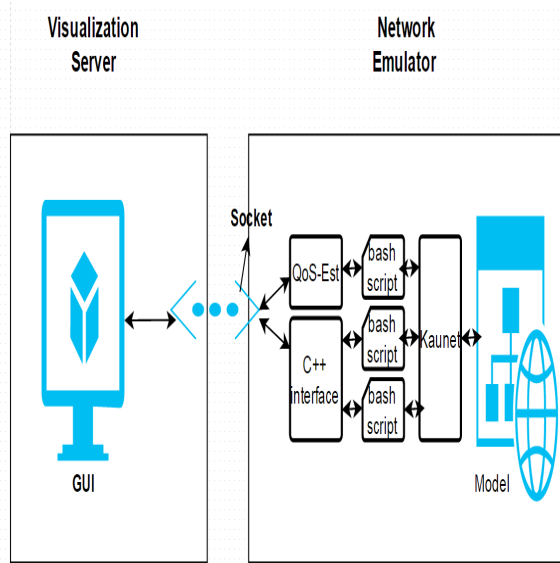

Fig. C.2: System Model for On-line Configuration of the Network Emulator

### 4.1 Visualization Interface

The Google Maps API which allows geometrical shapes (such as circles, rectangles, polylines, and pop up windows) to be overlaid on the standard maps provided by Google is used for the UI (User Interface) in order to visualize and configure the assets, voltage controllers and the connection between them. Even though this API is implemented in JavaScript, a wrapper that allows this to be accessed in Java is used for more robust data transfer and calculations. An example of the UI implemented can be seen in Figure C.3.

Assets are drawn as rectangles of varying colors where voltage controllers are drawn as standard circles. Colors indicate QoS levels for connections used by the particular asset. Each asset is colored with respect to its average quality based on the connections that it is consisted of (shown by the polylines connected).

From the UI it is also possible to send data back to the network emulator. Specifically, by clicking on a polyline we can change the current connection of an asset (e.g. from LTE to GPRS). In this way it is easy to re-configure the technologies that the assets use in the case where low quality connections exist.

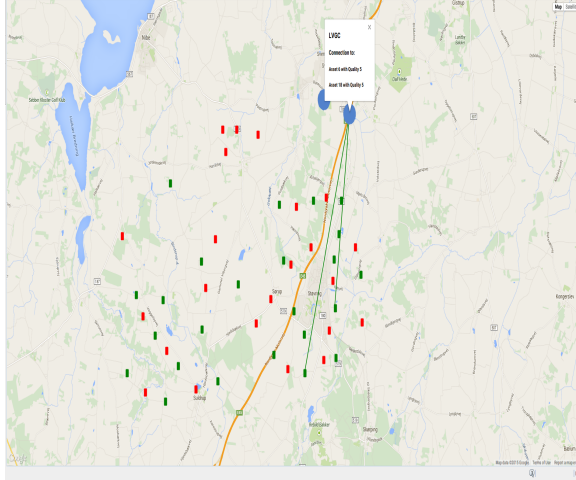

Fig. C.3: Screen Shot the Visualiation Interface Showing Assets and Communication Links

## Database

The way the data for visualization is retrieved is from a local database which is stored on the graphics server. It is formatted in a text file and its structure can be seen in table 1:

Table C.1: Entry of Database that is consisted of an asset with two connections

1,	56.909777,	9.913101,	3,	green,	5,	green,
----	------------	-----------	----	--------	----	--------

An entry is sorted in the following order: ID, latitude, longitude, connections. Each connection is defined by its ID following the color denoting the QoS level.

## 4.2 Kaunet Configuration

### Network Emulation

Network emulation is commonly used to evaluate and examine the behavior and performance of applications and transport layer protocols [8]. Its advantageous over simulations in that we can use wide range of real implementations of protocols and applications while testing the scenarios.

Figure C.4 is a schematic model description of the processing performed by KauNet queues. Pipes made of the three types of queues are used to generate introduce traffic delays, packet losses and changing other parameters. To elaborate more on the three types of queues and how they are used to change the parameters:

## 4. System Model

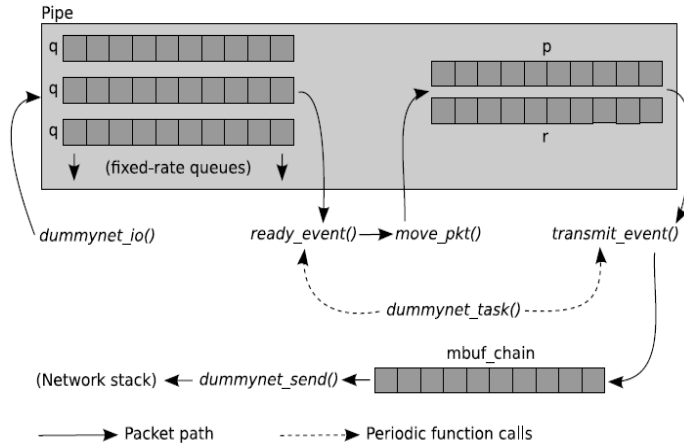

Fig. C.4: KauNet Pipe Used for Modeling QoS Parameters by Network Emulator [8]

The queues denoted by **q** are reception queues, or bandwidth queues. Packets coming from the network are put on wait for some time span, a delay equal to the transmission time for the emulated communication link. When the arriving traffic rate is higher than the bandwidth on the emulated communication link, the queues will add up introducing queuing delay on top of transmission time delay. During the occasion of overflowing, the queuing scheme used will determine on how the packets are dropped. The size of **q** is configurable according to the scenarios used and has a default value of 100.

The second type of queue as shown by the schematics **p** is a delay line queue where packets are made to wait for a period specified by the emulated delay pattern file to that corresponding packet.

The third type of queue is reordering queue **r**. It is used by KauNet as per the information set on the pattern file. It has a simple mechanism where it holds the packets selected for reordering before it is put in the delay line queue. Packets not chosen for reordering bypass this queue completely.

### 4.3 Network Sockets

The connection between the Network emulator and the graphics server is implemented with a UDP socket. This is mainly due to the need of a continuous stream of data in order to retrieve information and update the graphics server in real time, since the network patterns can change dramatically over time.

For this, we are proposing C++ interface configuring scripts using a fea-

ture of Bash that allows a programmer to send and retrieve data from a device socket that we can build. This is especially handy because we have a service running on our system that is listening for data on a port, and a shell script that handles setting the parameters for KauNet pipes.

#### 4.4 Network Emulation Configuration

To understand the process, let us go through steps taken to set up the whole system. During Initialization phase, the original structure of the network is located in the graphics server. Therefore, all the information regarding the assets is sent to the network emulator via the C++ interface used by calling the corresponding bash scripts used to set up the network emulator. The network emulator and the graphics server need to use the same identification code. The most important information that is sent is the ID and link configurations of each asset, which will be used for adjusting the emulated communication technologies.

The next phase is sending network parameter Information from the network emulator to the graphics server. The medium that converts the emulations into the graphics server's format is the QoS estimator(see Figure C.2).

After getting information regarding quality of each link, through the UI, connections can be configured in case when one technology does not provide the required QoS parameters. As seen in Figure C.3, this change can be made by clicking on a connection and choosing the desired technology. The network emulator is then notified and creates a new network emulation which will be visualized by the GUI.

### 5 Conclusion

This article provides a general but complete view of how on-line configuration of network emulation can be modeled and implemented for intelligent power system setups. In essence, smart energy testbeds are built to support and incorporate different layers on the current smart grid systems. This proposal has shown heterogeneous communication infrastructures can be supported by using network emulation tools, in our case KauNet. On-line monitoring and configuration platform is also proposed by using visualization server and configuration interfaces to facilitate exchange of status details on the fly.

The major advantage of this set up is, effect of communication QoS parameters on multiple control layer applications can be tested on-line. Furthermore, a number of power system assets can be connected and studied. This will be very useful for making detailed analysis of its communication requirements, proposal and tests of appropriate protocol architecture and the

choice of appropriate communication technologies for different case studies.

## Acknowledgment

The authors would like to thank European Community's Seventh Framework Programme (FP7/20072013) under grant agreement no. 318023 for financial support.

## References

- [1] S. Consortium, "Sustainable and robust networking for smart electricity distribution," 2014, <http://sunseed-fp7.eu/>.
- [2] F. Iov, *Smart Energy Systems Lab*, [www.smart-energy-systems-lab.et.aau.dk](http://www.smart-energy-systems-lab.et.aau.dk).
- [3] A. Zaballos, A. Vallejo, and J. M. Selga, "Heterogeneous communication architecture for the smart grid," *IEEE Network*, vol. 25, no. 5, pp. 30–37, September 2011.
- [4] Z. Fan, P. Kulkarni, S. Gormus, C. Efthymiou, G. Kalogridis, M. Sooriyabandara, Z. Zhu, S. Lambotharan, and W. H. Chin, "Smart grid communications: Overview of research challenges, solutions, and standardization activities," *IEEE Communications Surveys Tutorials*, vol. 15, no. 1, pp. 21–38, First 2013.
- [5] "Ieee standard communication delivery time performance requirements for electric power substation automation," *IEEE Std 1646-2004*, pp. 1–24, 2005.
- [6] C. I. Ciontea, R. Pedersen, T. L. F. Kristensen, C. E. Sloth, R. L. Olsen, and F. Iov, "Smart grid control and communication: The smartc2net real-time hil approach," in *2015 IEEE Eindhoven PowerTech*, June 2015, pp. 1–6.
- [7] J. Garcia, E. Conchon, T. Pérennou, and A. Brunstrom, "Kaunet: improving reproducibility for wireless and mobile research," in *Proceedings of the 1st international workshop on System evaluation for mobile platforms*, ser. MobiEval '07. New York, NY, USA: ACM, 2007, pp. 21–26. [Online]. Available: <http://doi.acm.org/10.1145/1247721.1247726>
- [8] J. Garcia, P. Hurtig, A. Brunstrom, and T. Hal, *KauNet 2.0: Design and Usage*, <https://www.cs.kau.se/cs/research/kaunet/documentation/KauNet-2.0-documentation.pdf>.

## References

# Paper D

## Analysis of Information Quality in event triggered Smart Grid Control

Thomas le Fevre Kristensen, Rasmus L. Olsen, Jakob G.  
Rasmussen

The paper has been published in the  
*2015 IEEE 81st Vehicular Technology Conference (VTC Spring), Glasgow, 2015,*  
*pp. 1-5.*

© 2015 IEEE

*The layout has been revised.*

## 1 Abstract

The integration of renewable energy sources into the power grid requires added control intelligence which imposes new communication requirements onto the future power grid. Since large scale implementation of new communication infrastructure is infeasible, we consider methods of increasing dependability of existing networks. We develop models for network delays and information dynamics, and use these to model information quality for three given information access schemes in an event triggered control scenario. We analyse the impact of model parameters, and show how optimal choice of information access scheme depends on network conditions as well as trade-offs between information quality, network resources and control reactivity.

## 2 Introduction

Today energy is mainly produced using non-renewable energy sources [1]. However, it is desired to rely more and more on several types of renewable energy sources. Wind turbines and solar panels are gaining popularity in households, meaning that energy production is changing from a more centralized system to a highly distributed system. In addition, the energy production is moving from high voltage(HV) and medium voltage(MV) power grids to the low voltage(LV) power grid. To enable the power grid to handle the requirements of the highly dynamic energy production from renewable energy sources at the low voltage level, it must be possible for the distribution grid to have better control of grid assets.

To facilitate added control intelligence in smart grid systems, a communication infrastructure must be in place as well as functionality to allow grid asset control, which for the LV grid is non-existing. Since the assets are highly distributed, dependable communication is required to allow proper grid operation, however, this is not without challenges since several trade-offs must be made [2].

Since large scale implementation of new communication infrastructure is not economically feasible, existing communication infrastructures are considered. However, existing communication infrastructures must be wide spread enough to cover the entire power grid, and have to be shared with the current users. This causes heterogeneous network behaviour, which must be considered when designing a system that must provide high dependability like power grid systems.

This problem can be tackled from several angles: [3] investigates in numerous articles how heterogeneous networks can be taken into account when designing control systems. Similarly [4] shows how control loop intervals can be changed dynamically depending on communication network quality. In



### 3. Scenario description

this paper we investigate the problem from a network perspective by attempting to increase dependability of the communication network in a smart grid low voltage control scenario. [5] develops a middleware solution for adapting control set-points to counter poor network performance. However, this solution is limited to a specific controller type. In this paper we propose a middleware solution that can be generalized to a wider set of controllers by extending the work of [6] and adapt information access strategies based on the probability of the controller using incorrect information. The impact of the mismatch probability (mmPr) on communication network buffers is investigated for different access strategies in a context management system in [7].

In this paper we present models for the mmPr in three different information access schemes in a smart grid low voltage control scenario, based on developed information and network Quality of Service models. We evaluate the models and conclude on the trade-offs put forth by the different access schemes.

We start by defining the considered control scenario in section 3, where we also define communication patterns for the different information access schemes. In section 4 we present the used information and network models, as well as the developed mmPr models. The resulting model dynamics are shown and discussed in section 5, and finally we draw conclusions in section 6.

## 3 Scenario description

We are considering an event driven voltage controller controlling several assets in a low voltage power grid. The controller is event driven, meaning that the assets runs on their own until a voltage has exceeded its threshold as illustrated in Figure D.1. Here, two voltage bands are illustrated, a hard limit defined by the grid codes and a soft threshold defined by the controller to ensure the hard limit is never reached. When the voltage threshold is exceeded at a point in the grid, the controller must handle the problem locally (see Figure D.2). The voltage is measured at sensors in the assets and an event will be detected by the assets physically close to the point of the event.

The group of assets handling the event and the group of assets detecting is not necessarily the same, but can, for simplicity, be assumed to be. This means that for a single event only the small group of assets is affected and all other can be disregarded. Group sizes will be in the order of 5-10 assets, compared to the 100-200 assets in a typical low voltage grid. When an event happens, the following must happen:

1. The controller must become aware of the event.

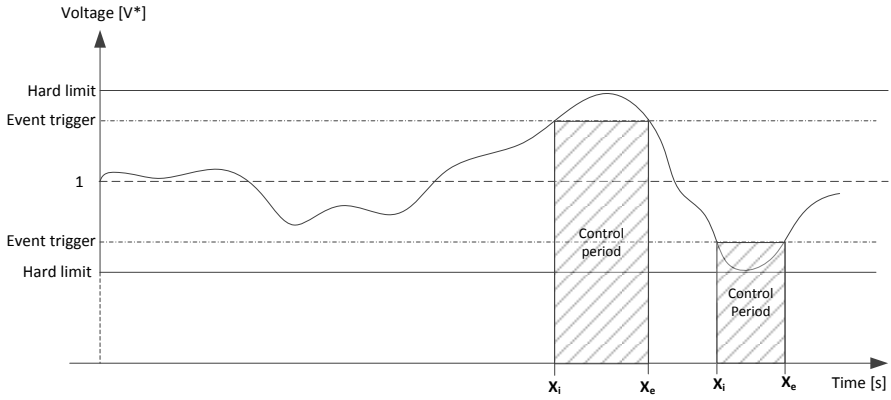

Fig. D.1: Definition of the events in the grid that triggers a (series of) control action.

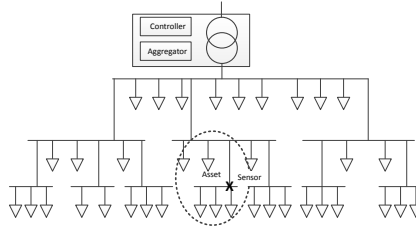

Fig. D.2: An example of an electrical low voltage grid.

2. The controller will calculate set points based on the assets' flexibility.
3. The control set points must be distributed to the assets.

In this scenario we consider the response time ( $t_{\text{response}}$ ), the time from a voltage event happens, until new set points has been distributed, and the mismatching time ( $t_{\text{mmPr}}$ ), the time from flexibility information is read at the asset, until the set points has been distributed. To calculate new set points when an event is detected, the controller must have information about the available flexibility of the assets. The controller does not necessarily need flexibility information from all affected assets and will only ask the relevant assets for information before determining new set points for the assets. This information flow is illustrated on Figure D.3; here the total response time of the controller is shown ( $t_{\text{response}}$ ), as well as the time in which a change in flexibility information could lead to the controller determining new set points based on outdated information ( $t_{\text{mmPr}}$ ). This scheme for accessing flexibility information will be denoted the reactive scheme. For the message sequence diagrams the following notation is used:  $u_i$  is the delay experienced

### 3. Scenario description

by the  $i$ 'th message sent to the controller;  $d_i$  is the delay experienced by the  $i$ 'th message sent from the controller;  $F_i$  denotes the time at which the  $i$ 'th flexibility information change occurs; and  $U_i$  is the time at which the  $i$ 'th flexibility information is sent from the asset.

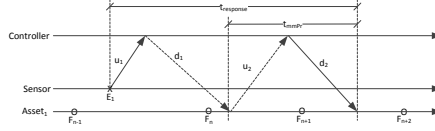

**Fig. D.3:** Message sequence diagram showing the information flow when a voltage threshold is exceeded using the reactive approach to access flexibility information.

Alternatively the flexibility information could be accessed by an information access scheme independent on voltage events. Figure D.4 shows this for flexibility updates sent to the controller using a periodic scheme. For mathematical simplicity these flexibility updates will be sent according to a Poisson process. As seen on Figure D.4, this scheme will decrease the controller's response time, but increase the time where changes in the flexibility can lead to information mismatch. This access scheme will be denoted the proactive periodical scheme.

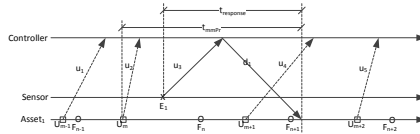

**Fig. D.4:** Message sequence diagram showing information flow when flexibility information is accessed periodically independent of voltage events.

Additionally we consider a proactive scheme where flexibility information is sent from the asset using an event driven process, i.e. the asset sends flexibility information whenever it changes. This access scheme is shown in Figure D.5.

In addition to the different information mismatch times and response times, the three schemes uses different network resources. With an average rate of voltage events of  $\lambda_V$ , an average rate of flexibility events  $\lambda_F$  and an average rate of updates for the periodical scheme of  $\tau$ , the traffic from each scheme can be described as the average number of packets sent per time interval:

$$R_{\text{rea}} = 4 \cdot \lambda_V \quad (\text{D.1})$$

$$R_{\text{per}} = \tau + 2 \cdot \lambda_V \quad (\text{D.2})$$

$$R_{\text{ev}} = \lambda_F + 2 \cdot \lambda_V \quad (\text{D.3})$$

From these it is seen that if voltage events are very common compared to the others, the reactive scheme will cause higher network loads, whereas if  $\tau$  or  $\lambda_F$  are significantly higher than  $\lambda_V$ , the reactive scheme will be more efficient with respect to network resources. Ultimately this will come down to a trade-off between network resources and control performance. Control performance is, however, delimited from this paper.

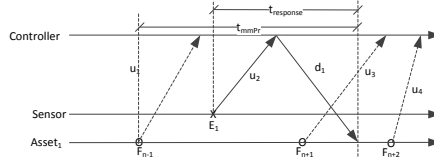

**Fig. D.5:** Message sequence diagram showing information flow when flexibility information is accessed using the proactive event driven process.

## 4 Mismatch probability modelling

In this paper we investigate how to determine optimal information access schemes using mmPr as a scalar performance metric. The mmPr will be modelled mathematically for the reactive and proactive periodical schemes, whereas simulations will be used to evaluate the proactive event driven scheme. Simulations are used for this since dependability between the information upload times and flexibility events results in high mathematical complexity for this model. For the models insignificant processing delays compared to the network delays are assumed, but processing delays can be incorporated into the network delays by convolution. It is also assumed that the assets and the sensors are on the same network and, therefore, share the same independent network delay distributions. It is also assumed that updates happens with time intervals according to a Poisson process for the periodical scheme. Since access schemes can be chosen individually for each asset, only a single asset will be considered for the the mmPr models. In addition to the mmPr, we also consider the response time of the controller given by its density function  $f_{\text{resp}}$ . Although a mathematical model for the mmPr in the proactive event driven scheme was not found, the response time distribution for this scheme was determined.

Generally we define the mmPr as:

$$Pr(mm) = \int_0^{\infty} Pr(mm|t) f_{mmPr}(t) dt \quad (\text{D.4})$$

where,  $Pr(mm|t)$  is the probability that the offered flexibility has decreased

#### 4. Mismatch probability modelling

during the time  $t$  and  $f_{\text{mmPr}}(t)$  is the probability density function of the mismatching time.

To construct the mismatching time density we consider two density functions:  $f_u(t)$  is the distribution of network delay for the upload of flexibility information and voltage events, and can be chosen as any appropriate distribution;  $f_d(t)$  is the distribution of network delay for the download of set points, and can also be chosen as any appropriate distribution. Using these and an update rate of  $\tau$  for the periodical scheme,  $f_{\text{mmPr}}$  and  $f_{\text{resp}}$  can be constructed for the different access schemes:

$$f_{\text{mmPr,rea}} = (f_u * f_d)(t) \quad (\text{D.5})$$

$$f_{\text{resp,rea}} = (f_u * f_u * f_d * f_d)(t) \quad (\text{D.6})$$

$$f_{\text{mmPr,per}} = (f_d * f_w)(t) \quad (\text{D.7})$$

$$f_{\text{resp,per}} = (f_u * f_d)(t) \quad (\text{D.8})$$

$$f_{\text{resp,ev}} = (f_u * f_d)(t) \quad (\text{D.9})$$

Here,

$$f_w = \exp\left(-\tau \int_0^t F_u(v) dv\right) \tau F_u(t) \quad (\text{D.10})$$

### 4.1 Information modelling

To be able to define  $Pr(mm|t)$ , a suitable model for the flexibility information must be defined. We model the flexibility information using a Markov birth/death chain with the states representing the amount of flexibility offered by the asset, shown on Figure D.6. In this model, we define an information mismatch as the system being in a state offering less flexibility when the set points have been distributed than it did when the information was read (i.e.  $i > j$  for  $S(t) = S_i$  and  $S(t + \Delta T) = S_j$  for some  $\Delta T > 0$ ).

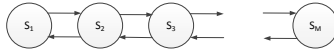

Fig. D.6: Markov chain model of flexibility.

We define the Markov chain using the generator matrix  $\mathbf{Q}$  (as shown in Equation D.11 for a Markov chain of  $M$  states), and calculate the stationary probabilities  $\mathbf{f}$  from the constraints shown in equation D.12 and D.13. We also define  $p_{ij}(t)$  as the probability of being in state  $j$  at time  $t$  given that the system where in state  $i$  at time 0. This can be calculated from the generator matrix as shown in equation D.14

$$\mathbf{Q} = \begin{bmatrix} -\lambda_{12} & \lambda_{12} & 0 & \cdots & 0 \\ \lambda_{21} & -(\lambda_{21} + \lambda_{23}) & \lambda_{23} & 0 & \vdots \\ 0 & \lambda_{32} & -(\lambda_{32} + \lambda_{34}) & \lambda_{34} & \vdots \\ \vdots & \vdots & \ddots & \ddots & \vdots \\ 0 & 0 & \cdots & \lambda_{M(M-1)} & -\lambda_{M(M-1)} \end{bmatrix} \quad (\text{D.11})$$

$$\mathbf{1}\mathbf{Q} = \mathbf{0} \quad (\text{D.12})$$

$$\sum_i \mathbf{1}_i = 1 \quad (\text{D.13})$$

$$p_{ij}(t) = \left[ e^{t\mathbf{Q}} \right]_{ij} \quad (\text{D.14})$$

Using this model, the probability of information mismatch for a given time horizon can be calculated as shown in equation D.15.

$$Pr(mm|t) = \sum_{i=1}^M \left( \mathbf{1}_i \sum_{j=1}^{i-1} p_{ij}(t) \right) \quad (\text{D.15})$$

The complete mmPr model can now be written out for each access scheme.

$$Pr(mm_{\text{Rea}}) = \int_0^\infty \sum_{i=1}^M \left( \mathbf{1}_i \sum_{j=1}^{i-1} p_{ij}(t) \right) (f_u * f_d)(t) dt \quad (\text{D.16})$$

$$Pr(mm_{\text{Per}}) = \int_0^\infty \sum_{i=1}^M \left( \mathbf{1}_i \sum_{j=1}^{i-1} p_{ij}(t) \right) (f_d * f_w)(t) dt \quad (\text{D.17})$$

## 5 Analysis of parameter impact on mmPr

To obtain the results shown in this section, we assume exponentially distributed network delays. For each result shown, a single parameter is varied within the given range, and all other parameters kept constant at a default value. These parameter values are shown in table D.1. The Markov chain used in this evaluation is assumed to have equal rates of state change everywhere (i.e.  $\lambda_{ij} = \lambda$  where  $j = i + 1$  for  $i < M$  and  $j = i - 1$  for  $i > 1$ ).

Figures D.7 and D.8 show the time distributions of mismatching time and response times respectively. Here it is seen that while the reactive scheme provides the shortest mismatching times, it comes at the price of increased response times. The two proactive schemes provides identical response times, though the event based scheme provides higher mismatching times than the periodical. Given this high mismatching time, it is expected that the event

## 5. Analysis of parameter impact on mmPr

Parameter	Value	Unit
Simulation iterations	25000	[.]
Default mean delay	0.2	[s]
Mean delay range	[0.05,5]	[s]
rate of flexibility change, $\lambda$	1	[s <sup>-1</sup> ]
number of flexibility states	20	[.]
Default rate of periodic update, $\tau$	4	[s <sup>-1</sup> ]
Rate of periodic update range, $\tau$	[1,20]	[s <sup>-1</sup> ]
Rate of voltage events	0.33333	[s <sup>-1</sup> ]

**Table D.1:** Parameters used to obtain the results shown in this section.

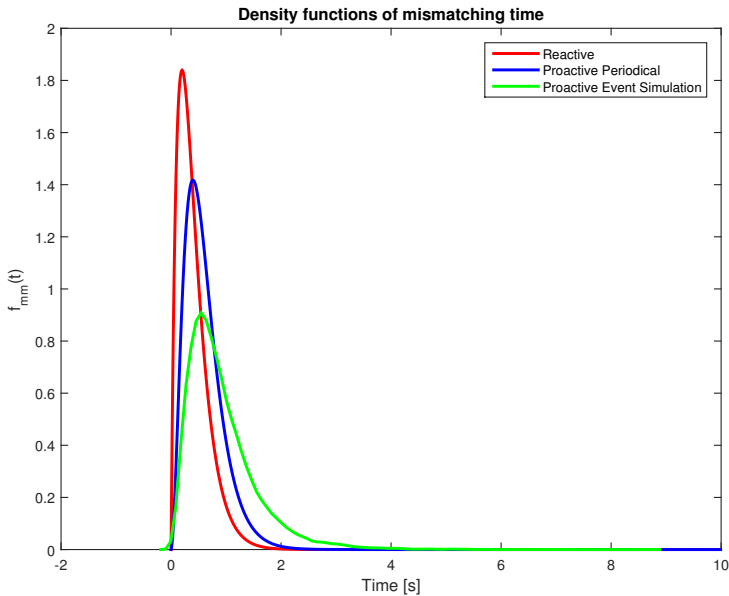
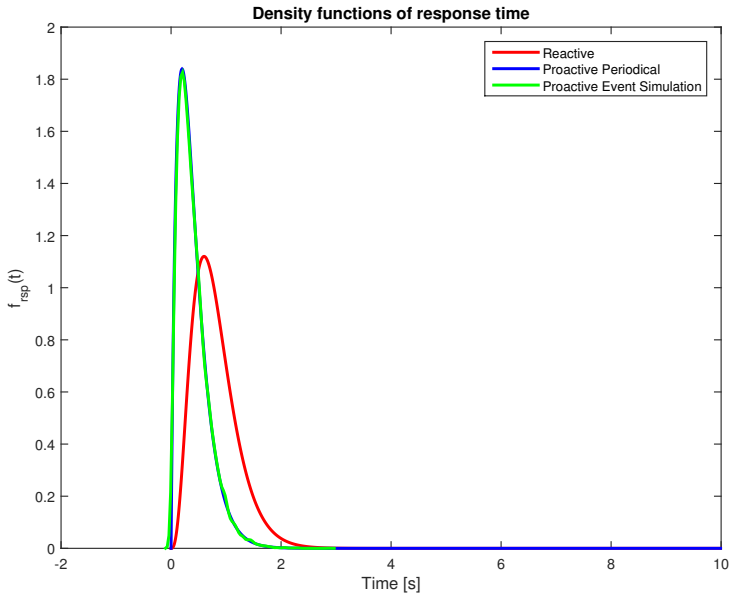

**Fig. D.7:** Density functions of mismatching time showing how the reactive scheme provides the smallest mismatching time of the three.

based scheme provides the highest mmPr, and the reactive scheme the smallest.

Figure D.9 shows the change in mmPr when the mean delay of the network is increased. Here it is seen, in contrast to the time densities, that the periodical scheme provides the highest mmPr for low network delays, but equal to the event driven scheme for higher delays. The event driven scheme, provides equal mmPr than the reactive scheme for small delays, but performs better for high delays.

By varying the update rate of the periodical scheme, Figure D.10 is pro-



**Fig. D.8:** Density functions of response time showing the reactive scheme providing higher response times than the two other schemes.

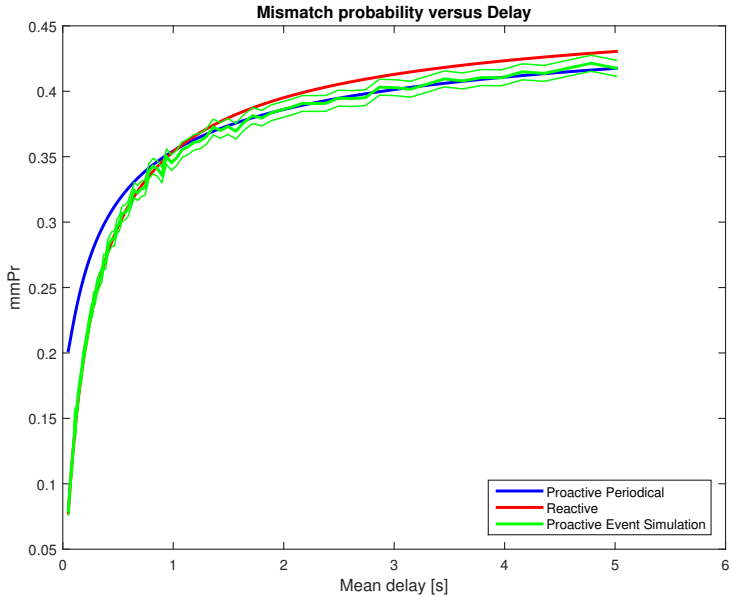

**Fig. D.9:** Mismatch probability versus Delay. Shown with 95% confidence intervals in dashed lines for the simulated results.



## 6. Conclusion

duced. It is seen that at an update rate of 16 times the flexibility change rate, the periodic scheme starts to out perform the other schemes.

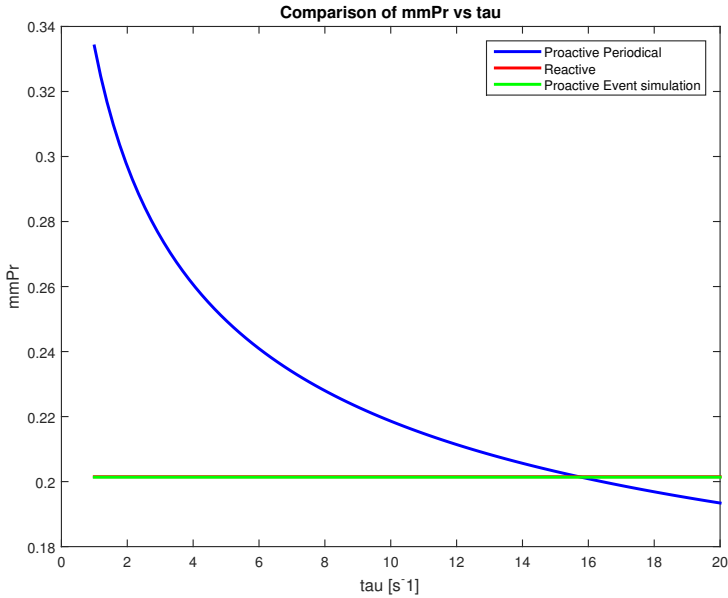

Fig. D.10: Mismatch probability versus periodical update rate.

The trade off between mmPr and response time is shown in Figure D.11, where it is seen that the periodical scheme can provide both low mmPr and low response time; however, as seen on Figure D.12 it comes at the cost of large amounts of network traffic generation. Here it is also seen how low mmPr and low network traffic generation can be achieved using the reactive scheme. However, the impact of the increased response time on control performance is yet to be seen.

## 6 Conclusion

In this paper we consider communication network optimization of a low voltage grid controller in a smart grid setting. We define models for information dynamics and communication network delays, and present models for mmPr evaluation of communication networks. These models are developed so they can be generalized to any controller using similar communication patterns during operation. We consider three different information access schemes as optimization parameter for the communication network, reactive, proactive with periodic updates and proactive with event driven updates. The three access schemes were evaluated partly analytically and partly through simu-

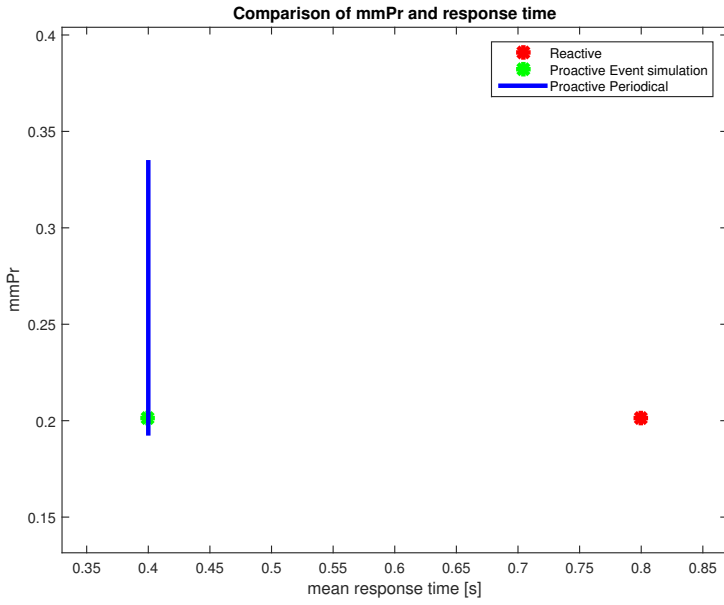

Fig. D.11: Mismatch probability versus response time.

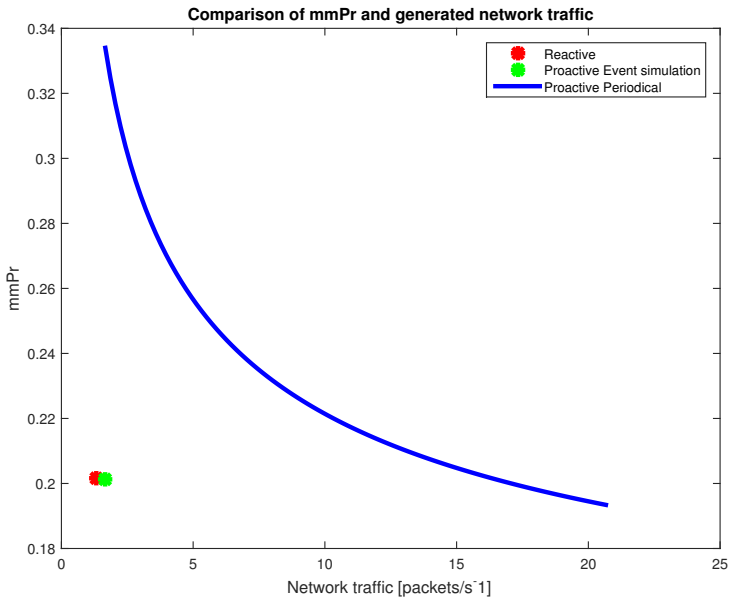

Fig. D.12: Mismatch probability versus generated network traffic in packets.

lations. Through this evaluation we show how information access optimality

is a trade-off between response time, mmPr and used network resources. We show how network resources can be spent to achieve low response time and mmPr using the periodical scheme, how low mmPr and low network traffic generation can be achieved at the cost of response time through the reactive scheme, and finally how the event based scheme can provide a trade-off between all three.

In this paper we show how mmPr can be modelled and how different access schemes influence it. However, several topics remains for future studies like: Development of a feasible model for the event driven approach; determination of exact trade-offs using realistic information and delay models; determination of the influence of mmPr on actual control performance; and evaluation in a testbed implementation.

## Acknowledgment

The research leading to these results has received funding from the European Communitys Seventh Framework Programme (FP7/20072013) under grant agreement No318023 for the SmartC2Net Project

## References

- [1] E. styrelsen, "Energistatistik 2010," 2010, iISBN: 978-87-7844-908-5.
- [2] Y. Yan, Y. Qian, H. Sharif, and D. Tipper, "A survey on smart grid communication infrastructures: Motivations, requirements and challenges," *Communications Surveys Tutorials, IEEE*, vol. 15, no. 1, pp. 5–20, 2013.
- [3] W. P. M. H. Heemels, A. R. Teel, N. van de Wouw, and D. Nešić, "Networked control systems with communication constraints: Tradeoffs between transmission intervals and delays," in *2009 European Control Conference (ECC)*, Aug 2009, pp. 4296–4301.
- [4] M. Pohjola, "Adaptive control speed based on network quality of service," in *Control and Automation, 2009. MED '09. 17th Mediterranean Conference on*, 2009, pp. 784–789.
- [5] J. Madsen, T. le Fevre Kristensen, R. Olsen, H.-P. Schwefel, and L. Totu, "Utilizing network qos for dependability of adaptive smart grid control," in *Energy Conference (ENERGYCON), 2014 IEEE International*, May 2014, pp. 859–866.
- [6] M. Bøgsted, R. L. Olsen, and H.-P. Schwefel, "Probabilistic models for access strategies to dynamic information elements," *Performance*

## References

*Evaluation*, vol. 67, no. 1, pp. 43 – 60, 2010. [Online]. Available: <http://www.sciencedirect.com/science/article/pii/S0166531609001175>

- [7] A. Shawky, R. Olsen, J. Pedersen, and H. Schwefel, "Network aware dynamic context subscription management," 2013, a continuation of the MMPr work done at Aalborg University, accepted for publication.

# Paper E

## Information-Quality based LV-Grid-Monitoring Framework and its Application to Power-Quality Control

Mislav Findrik, Thomas le Fevre Kristensen, Thomas  
Hinterhofer, Rasmus L. Olsen, Hans-Peter Schwefel

The paper has been published in the  
*Ad-hoc, Mobile, and Wireless Networks: 14th International Conference,  
ADHOC-NOW 2015, Athens, Greece, June 29 – July 1, 2015, Proceedings*

© 2015

*The layout has been revised.*

The integration of unpredictable renewable energy sources into the low voltage (LV) power grid results in new challenges when it comes to ensuring

power quality in the electrical grid. Addressing this problem requires control of not only the secondary substation but also control of flexible assets inside the LV grid. In this paper we investigate how the flexibility information of such assets can be accessed by the controller using heterogeneous off-the-shelf communication networks. To achieve this we develop an adaptive monitoring framework, through which the controller can subscribe to the assets' flexibility information through an API. We define an information quality metric making the monitoring framework able to adapt information access strategies to ensure the information is made available to the controller with the highest possible information quality. To evaluate the monitoring framework, an event-driven voltage controller is simulated in an LV grid. This controller utilizes the flexibility of photovoltaic (PV) panels to get the voltages into acceptable ranges when the limit is exceeded. This is done by controlling the grid periodically during the time interval that starts when a voltage limit is exceeded and ends when an acceptable voltage level is reestablished. We show how the volatile behaviour of the PV panels causes overvoltages in a baseline scenario. We then show the controller's ability to keep the voltages within their limits. Lastly, we show how control performance can be increased by optimizing information access strategies.

## 1 Introduction

The current electrical grid is facing increased penetration of renewable energy resources. In particular, in the low voltage (LV) grid photovoltaic (PV) panels are being widely installed on rooftops of the end customers, and electric vehicles are expected to be strongly present. Thus, the end customers are transforming from passive consumers to active "prosumers" that can locally generate and feed the power into the grid. The volatile nature of PVs may lead to over-voltage problems that can occur very rapidly in time [1]. Overcoming this challenge requires control of LV grid assets in order to maintain the voltage profiles [2, 3]. Reference [4] outlines the evolution steps of the low voltage grid controlling approaches, starting from "local control" and gradually moving towards "advanced control" that utilizes active management and control via communication infrastructures with limited bandwidth and availability.

We present a monitoring architecture that facilitates operations of control approaches on top of heterogeneous off-the-shelf communication infrastructure with varying network properties. The existing off-the-shelf communication infrastructures are an economically feasible solution for last-mile coverage of LV grids. However, such network infrastructures may be shared (e.g. cellular networks) and are not highly dependable in providing sufficient quality-of-service (QoS). In order to tackle these problems we present a monitoring

## 2. Related Work

framework acting as an adaptive communication middleware. The framework features the ability to adapt to network QoS conditions and configure information access to demands of the control approach.

The paper is organized as follows: Section II covers the related work; in Section III the LV grid controller scenario is presented together with a description of the baseline data access scenario; in addition, assumptions on the communication network are presented. In Section IV the adaptive monitoring framework is defined and optimization approaches for information access are presented. Section V describes the simulation framework and shows the evaluation results of a monitoring framework. Finally, in Section VI conclusions are made and future research directions are outlined.

## 2 Related Work

Recently, in the domain of Network Control Systems a new control strategy called periodic event-triggered control (PETC) was proposed [5]. PETC is suited for applications where communication resources are scarce, hence we applied the basic principle of PETC (i.e. control triggered by an event) to a voltage control scenario. For the developed controller we analysed how different information access strategies are influencing performance of the controller and how information access can be adapted based on quality metric for sensor information called mismatch probability (mmPr) [6]. MmPr covers the aspect of real-time access, impact of access delays and access strategies on information accuracy in a distributed system and it was used to optimize access to location information for communication network optimization in References [7, 8]. In this paper, we applied information access scheduling techniques for PETC controllers in details described in References [9, 10], and analysed benefits of such scheduling on the voltage controller.

## 3 Power Quality Control Scenario

The scenario of this paper assumes a centralized low voltage grid controller (LVGC) located in a secondary (medium voltage to LV) substation. When more distributed power sources penetrate into the LV grid, voltage control becomes more challenging. In particular, the voltage rise is the major issue in LV grids with high share of PVs due to active power injection and small X/R ratios [11]. The purpose of our reference controller is to keep the voltage levels within defined range by regulating grid-interfaced PV inverters upon over-voltage occurrence. As mentioned in Reference [1], the advantage of having a centralized intelligent voltage control mechanism opposed to a local one at each PV lies in its ability to do fair and optimal decisions by orchestrating all resources in LV grid.

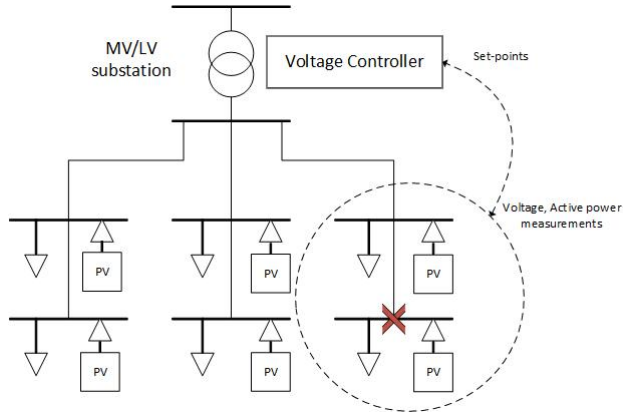

Fig. E.1: An example of a LV grid with PVs and overvoltage violation at the last bus

The controller relies on real-time measurements of voltages at the grid connection points (i.e. electrical buses) and information about active power injected from PVs. This section provides a detailed overview of the voltage control algorithm, describes a baseline communication pattern in which measurements are sent by the assets, and it presents assumptions on the communication network used in this paper. Note that the development of a voltage controller is not the purpose of the paper; instead the paper will use the described controller as the example of a controller that utilizes several assets distributed across the LV grid for solving the over-voltage problem, and for which information access is provided by the adaptive monitoring framework.

### 3.1 Voltage control approach

The basic principle of the voltage controller is to be active only in the case the measured bus voltages are above a pre-defined upper voltage threshold. The limit in our studies shall be set to 5% of the nominal voltage ( $1.05p_u$ ). Upon sensing the voltage violation the controller will be triggered to start running in the periodic time steps  $T_s$ . Due to radial topologies of LV grids PVs located upstream the feeder are contributing to voltage rise at Bus  $i$ . Therefore, to handle the over-voltage event at Bus  $i$ , the controller is designed not only to control injected power of PVs at Bus  $i$ , but also PVs located upstream the feeder of Bus  $i$ . The subset of upstream buses to which the control is spanning is denoted with  $X$  and cardinality of  $X$  with  $N$ . After each time step, the LVGC distributes set-points containing the maximal active power to PV inverters located at the bus where the voltage event has occurred and the upstream buses (see Figure E.1).



### 3. Power Quality Control Scenario

LVGC calculates PV set-points based on the difference between the nominal and the measured voltage at Bus  $i$  (when there is an over-voltage event at Bus  $i$ ), as well as the measured active power injection of PV at Bus  $i$  and PVs of the buses in Set  $X$ . Subsequently upon the arrival, the PV inverters use these set-points for limiting the maximal power injection. The detailed voltage control algorithm is given by Algorithm 2; where  $K_p, K_i$  denote proportional and integral gains, respectively, and  $t_{V_m}$  the time when voltage was above or below the threshold.

```

read  $V_{measured,i}, i \in BUS;$ 
if  $V_{measured} > 1.05$  then
   $err = V_{measured} - 1.05;$ 
   $P_{max \text{ bus } i} = P_{injected\_i} + K_p * err + K_i * \int_{t_{V_m} > 1.05}^{t_{V_m} < 1.05} err(\tau) d\tau$ 
  for  $b \in X$  do
     $P_{max \text{ bus } b} = P_{injected\_b} + K_p * err + K_i * \int_{t_{V_m} > 1.05}^{t_{V_m} < 1.05} err(\tau) d\tau$ 
  end
end

```

**Algorithm 2:** PI control algorithm for stabilizing the voltage at the bus  $i$  utilizing PVs at the bus  $i$  and the upstream buses  $b \in X$

The PV model used for evaluation purposes is adopted from the simulation framework in reference [12] (details are described in Section IV), where active power output in normal operation is given by:

$$p = \begin{cases} p_{rated}, & \text{if } \mu A I_{solar} \geq p_{rated} \\ \mu A I_{solar}, & \text{otherwise} \end{cases}$$

where  $\mu$  is the efficiency of the solar cells,  $A$  the area they cover, and  $I_{solar}$  the solar irradiance.

### 3.2 Baseline Data Access

The described controller is located in the secondary substation and needs to receive updates from the assets in the grid. A baseline data access is defined for each grid asset: the assets send their update messages to the LVGC according to a Poisson process where the parameter MTBU (Mean Time Between Updates) describes the mean time between updates. The Poisson updates are chosen since their arrival before the controller execution are random, thus yielding the average result as if fixed updates would be randomly scheduled in time. An update contains values of the local voltage and active power injection for each asset. In the evaluation section later, all assets will use the same MTBU parameters. The baseline data access is illustrated

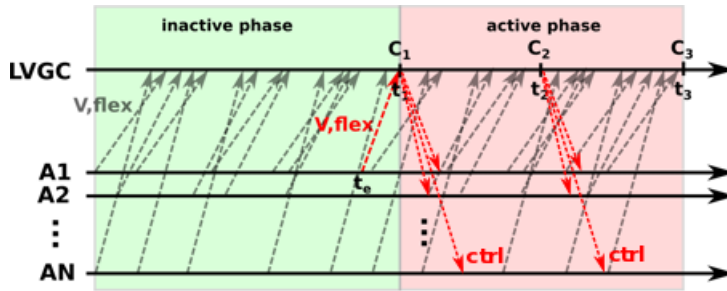

Fig. E.2: Baseline data access with Poisson interval updates

in Figure E.2. The figure also shows two phases. In the inactive phase, the controller receives updates from the assets but does not communicate new set-points. Only when triggered by an out-of band value of a voltage sensor (received at time  $t_1$  at the controller in Figure E.2), the controller transits to the active phase in which it communicates set-points to the assets.

### 3.3 Network modelling

We assume a reliable communication network, e.g. utilizing retransmissions to compensate for losses. Therefore, the network is abstracted via a stochastic process characterizing the message delays. For the evaluations in this paper, we use independent Poisson processes for the communication between the assets and the controller. A Poisson process is chosen, as a light tailed distribution (fast decaying tail) of transmission delays resulting from assumption that number of retransmissions follows a geometric distribution. The latter is true when the errors are independent of the size of the transmitting packet (see reference [13] for the details). The upstream delay  $U$  effecting the messages from the assets to LVGC is characterized by a rate  $\lambda_U$ , while downstream delay from LVGC to the assets is characterized by a rate  $\lambda_D$ . For the purpose of reducing number of parameters for the evaluation analysis, later on we assume that upstream and downstream delays have the same rate, e.g they are symmetric. Furthermore, in the evaluation, message re-ordering effects are neglected, since delay values are chosen such that  $MTBU > 1/\lambda_U$ , thus yielding a low probability of a message  $i - 1$  arriving before the message  $i$ . Also, it is assumed that network traffic generated by the controller and the sensors is negligible compared to other cross-traffic in the network, hence it will not have an impact on the delay distributions.

## 4 Adaptive Monitoring Framework

The main contribution of this paper is to show the benefits of using dynamic data access compared to the static baseline scenario. Consequently, this section contains a detailed specification of the adaptive monitoring framework.

### 4.1 Adaptivity Concept

This section describes architecture of the monitoring framework, together with the developed approach for adaptive data access. As already mentioned in the introduction section, we are using a grid control approach that is only active in case voltage levels exceed given boundaries. This approach of only being active if voltages are out-of-band assures minimal communication requirements (i.e. bandwidth), as no communication and control is needed under normal stable grid conditions. Furthermore, it allows the asset to produce/inject independently of the current power grid status in case voltage levels are stable. In case of a violation of a soft voltage threshold, the considered approach switches to periodic control until the voltages return to acceptable levels. As a consequence, we will investigate two different phases of the monitoring and control:

- inactive phase
- active phase

Figure E.3 depicts our dynamic data access approach, where no monitoring data transfers are happening prior to the active phase (i.e. prior to the reception of the voltage violation event at time  $t_e$ ). As a result, the input data for the first control step of the active phase needs to be acquired as a reaction to the voltage violation event. In this phase, we call it the *starting phase*, the controller can request its input data dynamically (e.g. subscription to the neighbouring controllable assets of the voltage event location) from the adaptive monitoring framework. After a configurable timeout (waiting time  $t_{wait}$ ), the voltage controller will do its first computation step  $C_1$  regardless of the complete reception of all asset flexibilities. In case some asset information is not available after  $t_{wait}$ , the controller cannot use it for control and the asset is considered to be a normal non-controllable load or producer. As a result, no set-point will be sent to this asset. For simplicity, the control messages are not depicted in Figure E.3. Arrows from the LVGC to the assets represent the request of data.

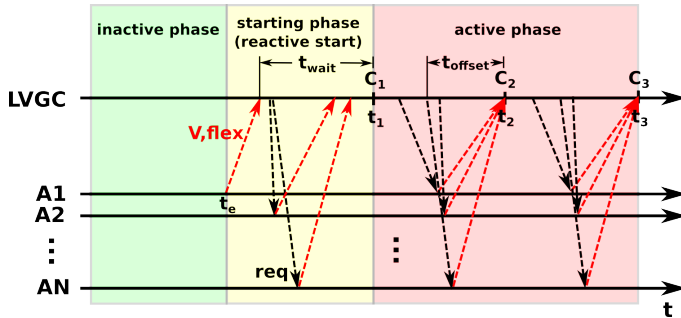

Fig. E.3: Reactive start approach

During the active phase, we investigate an approach that uses scheduling of updates as introduced in [9] in order to be synchronised with the voltage controller steps  $C_j$ . As a consequence, the resulting data quality is high as the delay between the measurements and the control step is minimised.

## 4.2 Task Management Approach

The *task manager* is the main component of the monitoring framework and is responsible for configuring, controlling and coordinating the adaptivity concept mentioned in the last section. The basic approach for the management of the full set of controller monitoring tasks is depicted in Figure E.4. It is based on a tight interlinking with the *Quality Estimator* and the *Network QoS*

#### 4. Adaptive Monitoring Framework

*Manager*, which are also sub-components of the monitoring framework: (1) The task manager can request a data quality estimation for a specific variable  $var_{id}$  and a set of access configurations  $cfg_{id1}, cfg_{id2}, \dots$ . A configuration  $cfg$  defines a specific access configuration (push, pull, event-based, scheduled, etc.). For this paper, we are focusing on the (scheduled) pull (i.e. request-reply) access technique. (2) After receiving a new estimation request, the quality estimator requests the communication network QoS options from the according monitoring source defined by  $var_{id}$ . (3) This request is answered with a set of QoS options  $QoS_1, QoS_2, \dots$  from the given source address. The set can be empty if there is no connectivity at all or it can contain multiple QoS objects if the connection can handle different priorities or because of the existence of multiple routes/technologies. A QoS object consists out of a delay distribution and a loss probability. For simplicity reasons, we consider only one QoS option per asset for the studies in this paper. (4) In case there is connectivity, the data quality estimation is acknowledged by returning a unique estimation id  $est_{id}$ , otherwise a NACK is returned. (5) Based on the available QoS options, the quality estimator can now compute the data qualities to be expected for the set of requested access configurations. The results of the data quality estimation is finally reported to the task manager by using the `updEstimation()` function. (6) The task manager will then decide for one access configuration, and the decision is sent to the quality estimator.

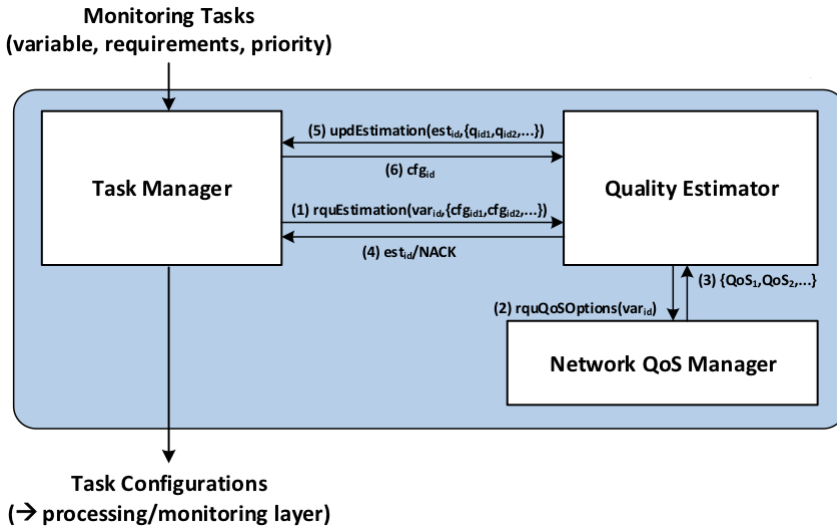

Fig. E.4: Monitoring Framework components

### 4.3 Information Quality Estimation

In this section we present the algorithms for quality estimation running inside of **Quality Estimation** component of the monitoring framework. The algorithms are used for optimizing the information access to the grid measurements (e.g. voltages and PV power outputs) for the controller described in Section II. The information access is optimized separately for the two phases of the grid state; namely, for the first one in which there is no overvoltage and controller is inactive and the second one in which overvoltage has occurred and controller is running in equidistant periodic time steps  $T_s$ .

In this paper we measure information quality using the mismatch probability (mmPr) metric. Let  $S(t)$  is the state of an asset and  $S'(t)$  be the state of the asset known by the controller.  $S'(t)$  is updated through the communication network making it a step function that only changes when updates arrive, whereas  $S(t)$  can be continuous. We then define the mmPr for the time instance at which the controller runs( $t_c$ ) as:

$$Pr(S(t_c) \leq S'(t_c)) \quad (E.1)$$

This quality metric is used because if the asset has less active power available than the controller thinks, the controller may determine set-points for the asset which are not implementable.

The mmPr depends on two factors: (1) the time from the information is read locally at the asset until the controller set-points have been distributed, which can be caused by network delays or caches. (2) the dynamics of the information, i.e. how quickly the information changes to a mismatching value. As stated previously network delays are modelled using Poisson processes. The dynamics of the available power of the PV inverters, considered in the control scenario, is modelled in continuous time through control theory. However, for the purpose of estimating information quality, this model is mapped into a Markov process for its mathematical benefits. This mapping is done by sampling the PV model, discretizing the samples, and fitting the transitions to a Markov process defined by its generator matrix  $Q$ .

#### Information access Optimization in Inactive Phase

In the starting phase, flexibility information will be sent using a reactive information access strategy. In this case, the mmPr for a single asset can be calculated as [10]:

$$Pr(mm) = \int_0^{\infty} Pr(mm|t) f_{mmPr}(t) dt \quad (E.2)$$

where  $Pr(mm|t)$  is the probability of the information changing to a mismatching value during the time  $t$ , and  $f_{mmPr}(t)$  is the density function of the total

#### 4. Adaptive Monitoring Framework

experienced delay. The total experienced network delay is here defined as the time from the information was read at the sensor until the controller has distributed set-points based on the information, and is, thereby, dependent on the information access strategy.

$Pr(mm|t)$  is computed from the Markov process describing the flexibility information. Since we consider the flexibility of assets, too much flexibility will have no negative consequences for the system, and the information is only considered to be mismatching if the flexibility of the asset is in a lower state when it is utilized than it was when the information was read. For a general Markov process defined by the generator matrix  $\mathbf{Q}$  this means [10]:

$$Pr(mm|t) = \sum_{i=1}^M \left( \mathfrak{B}_i \sum_{j=1}^{i-1} p_{ij}(t) \right) \quad (\text{E.3})$$

where  $\mathfrak{B}$  is the stationary probabilities of the Markov Chain,  $p_{ij}(t)$  is the probability of being in state  $j$  at time  $t$  given the state  $i$  at time 0, and can be calculated from standard transient Markov chain calculations [10].

$f_{mmPr}(t)$  is for the reactive information access strategy calculated in [10] as:

$$f_{mmPr,rea} = (f_u * f_d)(t) \quad (\text{E.4})$$

where  $f_u$  and  $f_d$  is the density function of the network delay in the upstream and downstream respectively. In this paper we consider several assets providing flexibility information. Therefore, the controller must either wait for all answers to arrive, or determine a proper time to wait before it runs using the information available. We optimize this time by minimizing the mmPr averaged over all relevant assets. However, since we now consider the controller running at the latest after a predetermined waiting time, the stochastic upstream network delay is replaced by the deterministic waiting time. Using this and the reciprocal of the network downstream delay  $\lambda_d$  we get:

$$f_{mmPr,rea} = f_d(t - t_{wait}) \quad , t > t_{wait} \quad (\text{E.5})$$

Using this, the mmPr,  $mmPr_{rec}$ , can be calculated for a single asset assuming the response was received before the waiting period was over. If the response was not received before the end of the waiting period, there is no old information to be used resulting in a certain information mismatch. Using this and the distribution of the upstream delay  $F_u(t)$  we can calculate the mmPr for a single asset as:

$$mmPr_{1Asset} = mmPr_{rec} F_u(t_{wait}) + 1 \cdot (1 - F_u(t_{wait})) \quad (\text{E.6})$$

This mmPr notion can be extended to N assets by conditioning on the number

of responses that is received and averaging over all assets.

$$mmPr_{tot} = \sum_{n=0}^N \frac{n \cdot mmPr_{1Asset} + (N-n)1}{N} \cdot Pr(n \text{ responses arrive}) \quad (E.7)$$

### Information access Optimization in Active Phase

Instead of getting pushed updates from the assets in Poisson intervals, the task manager utilizes pull access (e.g. request-response communication pattern) to retrieve the information from each controlled asset in the active phase. The goal of the task manager is to find  $T_{offset}$  value such that  $mmPr$  metric is minimized and asset information arrives before the controller executions  $C_i$  (see Figure E.3).  $T_{offset}$  is a function of upstream and downstream delays ( $\lambda_U$  and  $\lambda_D$ ) as well as information dynamics ( $\mathbf{Q}$  matrix). In recent paper [9] we derived analytical formulas for deriving  $mmPr$  curve for different data access strategies. Here, we recall the formula for case of pull data access:

$$mmPr_{pull} = \int_0^{T_o} \int_0^{T_o-t} \sum_{i=1}^S \pi_i Q_{i,i} [exp(Qs)]_{i,i} ds \int_0^{T_o-t} \lambda_U exp(-\lambda_U x) dx \\ \lambda_D exp(-\lambda_D t) dt + (1 - \int_0^{T_o} (\frac{\lambda_D \lambda_U}{\lambda_U - \lambda_D} exp(-\lambda_D x) + \frac{\lambda_D \lambda_U}{\lambda_D - \lambda_U} exp(-\lambda_U x) dx)) * \\ \int_0^{T_o} \int_0^{T_o+T_s-t} \sum_{i=1}^S \pi_i Q_{i,i} [exp(Qs)]_{i,i} ds \lambda_D exp(\lambda_D t) dt$$

From the equation above,  $T_{offset}$  is derived at the point where  $mmPr_{pull}$  is minimal. Due to its length, the closed-form solution is omitted from the paper.

## 5 Simulation Framework and Evaluation Results

In order to evaluate the monitoring framework we implemented a prototype of the publisher layer inside of DiSC simulation framework [12]. DiSC is MATLAB based open-source simulation framework that contains implementation of PV panels, as well as the data of real solar irradiation and household consumption collected in Denmark. Moreover, it allows verification of different control approaches. Utilizing DiSC framework we constructed a LV grid with 7 buses, each having 15 household loads connected together with PVs with total rated power of 7kW. DiSC tool was configured to generate data for all assets and to calculate voltages each second, which is the highest precision offered by the DiSC models. The voltage profile during a summer day was generated for all buses and shown in Figure E.5.

In normal operating conditions with no PVs in LV grid, the feeder voltage decreases as the distance from the substation increases. However, with PV installations at all buses the most far bus becomes the most sensitive one where overvoltage occurs first. Since simulating the whole monitoring stack takes significant amount of time our analysis is further focused on observing



## 5. Simulation Framework and Evaluation Results

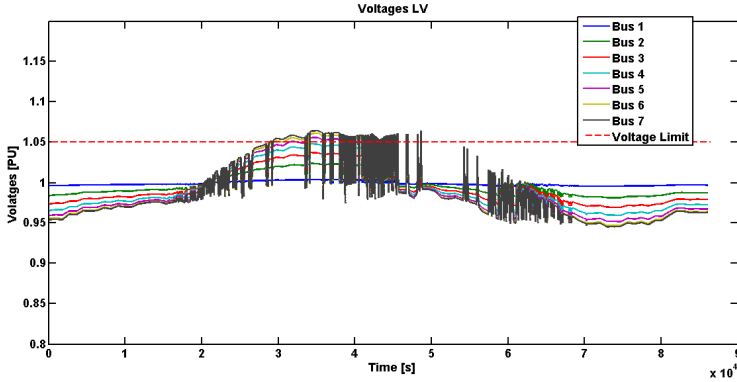

Fig. E.5: Voltage profile for all buses during 400 seconds (24 hours)

Fixed configuration parameters	Value
The controller period $T_S$ (active phase)	10sec
$K_p$ (Proportional gain of the controller)	3000
$K_i$ (Integral gain of the controller)	1000
$N$ (# of buses upstream used for over-voltage control)	1
# of Markov states in the information model	20
MTBU for baseline access (inactive and active phase)	10sec
Variable configuration parameters	Values
$T_w$	[4 6 7]sec
$T_{offset}$	[3.6 4.4 6.1]sec
Symmetrical mean delays $\frac{1}{\lambda_U} = \frac{1}{\lambda_D}$	[1 2 3]sec

the controller performance in a time interval from  $2.6 * 10^4s$  until  $4.5 * 10^4s$ , since in that time interval, overvoltage events are occurring at Bus 7. Furthermore, to compare the monitoring framework solution against the baseline data access a suitable performance index has to be defined. For this purpose we define Overvoltage Surface (OS) index. The index is calculated by multiplying time in which the bus suffered overvoltage with the voltage value subtracted by critical threshold 1.05pu (i.e integral of voltage curve going above 1.05pu). Note, that during zero delay conditions and infinite rate updates the controller would have OS index value 0 since overvoltage would never happen; worse QoS network conditions or different data access strategies would yield higher index value. The simulation configuration parameters for the controller, the baseline data access and the monitoring framework are given in Table E.1.

The baseline data access is compared against the monitoring framework adaptive over three different mean delay values, namely 1, 2 and 3 seconds in both directions. Adaptive parameters  $T_w$  and  $T_{offset}$  are calculated for corresponding delays using equations given in previous section, which are

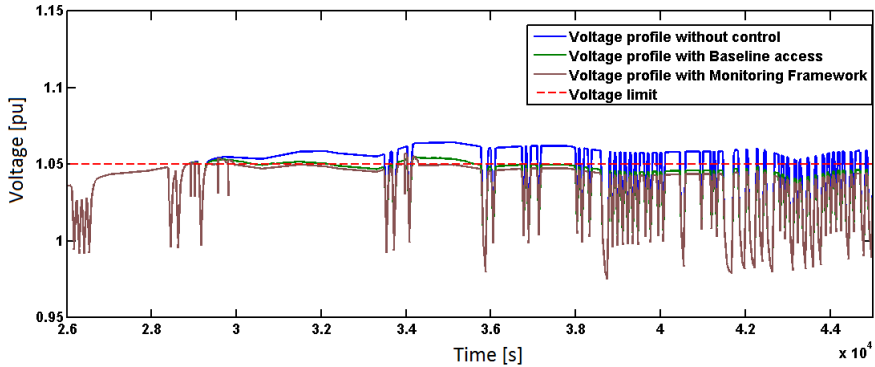

Fig. E.6: Voltage profile at Bus 7 for the reference control scenario with 1sec symmetric delays

Table E.2: Comparison of data access schemes based on OS index

Simulation Scenario		OS index
Without control (worst case)		11 494
Symmetric delays 1s	Baseline Data Access	2700,8
	The monitoring framework	1308,5
Symmetric delays 2s	Baseline Data Access	3644,0
	The monitoring framework	1352,1
Symmetric delays 3s	Baseline Data Access	5219,1
	The monitoring framework	1382,4

configured before the simulation runs. The comparison of voltage profiles when using the monitoring framework opposed to the baseline data access is shown in Figure E.6. For further analysis OS indexes are calculated from voltage profiles obtained for different delays and presented in Table E.2.

The results show that control, even with the poor data quality resulting from the baseline access scenario, is effective in reducing the OS index (hence reducing the overvoltage effect) by more than half for all network delays compared to the case without control. Moreover, the baseline scenario is significantly affected by the network delays, the increase from 1s to 3s causes the OS index to almost double. Using the optimized information access via the monitoring framework, the OS index is reduced for all network delays in comparison to the baseline data access. Hence, its sensitivity to changing network delays is significantly reduced.

## 6 Conclusion and Future Work

In this paper a novel monitoring framework for Smart Grid controllers with adaptive information access is presented. We provided a detailed descrip-

tion of the monitoring framework components and described the algorithms within components as well as their interaction. Furthermore, a sample controller for regulating voltage profiles in LV grid was specified and the benefits from the adaptivity provided by the monitoring framework are evaluated via the simulation with respect to the baseline data access. It is shown that control performance with the monitoring solution is significantly improved. The future work shall focus on extensive test-bed evaluation of the framework with different type of Smart Grid controllers running over heterogeneous access networks (power-line communication, cellular networks, xDSL and WiFi).

## Acknowledgments

This work is part of SmartC2Net research project, supported by the FP7 framework programme under grant No318023. FTW is also supported by the Austrian Government and City of Vienna within the competence center COMET.

## References

- [1] B. Ran, E. Negeri, N. Baken, and F. Campfens, "Last-mile communication time requirements of the smart grid," in *Sustainable Internet and ICT for Sustainability (SustainIT)*, 2013, Oct 2013, pp. 1–6.
- [2] J. Groenbaek, S. Bessler, and C. Schneider, "Controlling ev charging and pv generation in a low voltage grid," in *Electricity Distribution (CIRED 2013)*, 22nd Int. Conference and Exhibition on, June 2013, pp. 1–4.
- [3] F. Kupzog, R. Schwalbe, W. Prügler, B. Bletterie, S. Kadam, A. Abart, and M. Radauer, "Maximising low voltage grid hosting capacity for pv and electric mobility by distributed voltage control," *Elektrotechnik und Informationstechnik*, vol. 131, no. 6, pp. 188–192, 2014. [Online]. Available: <http://dx.doi.org/10.1007/s00502-014-0213-1>
- [4] A. Einfalt, F. Kupzog, H. Brunner, and A. Lugmaier, "Control strategies for smart low voltage grids," in *Integration of Renewables into the Distribution Grid, CIRED 2012 Workshop*, May 2012, pp. 1–4.
- [5] W. Heemels, M. Donkers, and A. Teel, "Periodic event-triggered control for linear systems," *Automatic Control, IEEE Transactions on*, vol. 58, no. 4, pp. 847–861, April 2013.
- [6] M. Bogsted, R. L. Olsen, and H.-P. Schwefel, "Probabilistic models for access strategies to dynamic information elements," *Performance*

## References

- Evaluation*, vol. 67, no. 1, pp. 43 – 60, 2010. [Online]. Available: <http://www.sciencedirect.com/science/article/pii/S0166531609001175>
- [7] J. Nielsen, R. Olsen, T. Madsen, and H. Schwefel, "On the impact of information delay on location-based relaying: A markov modeling approach," in *Wireless Communications and Networking Conference (WCNC), 2012 IEEE*, April 2012, pp. 3045–3050.
- [8] J. Nielsen, R. Olsen, T. Madsen, B. Uguen, and H.-P. Schwefel, "Location quality aware policy optimization for location based relay selection in mobile networks," *Wireless Networks*, 2015.
- [9] M. Findrik, J. Groenbaek, and R. Olsen, "Scheduling data access in smart grid networks utilizing context information," in *Smart Grid Communications (SmartGridComm), 2014 IEEE Int. Conference on*, Nov 2014, pp. 302–307.
- [10] T. Le Fevre Kristensen, R. Olsen, and J. Rasmussen, "Analysis of information quality in event triggered smart grid control," in *Vehicular Technology Conference (VTC Spring), 2015 IEEE 81st*, May 2015, pp. 1–5.
- [11] M. Juamperez, G. Yang, and S. Kjar, "Voltage regulation in lv grids by coordinated volt-var control strategies," *Journal of Modern Power Systems and Clean Energy*, vol. 2, no. 4, pp. 319–328, 2014. [Online]. Available: <http://dx.doi.org/10.1007/s40565-014-0072-0>
- [12] R. Pedersen, C. Sloth, G. B. Andresen, and R. Wisniewski, "Disc: A simulation framework for distribution system voltage control," in *2015 European Control Conference (ECC)*, July 2015, pp. 1056–1063.
- [13] D. Bertsekas and R. Gallager, *Data Networks (2Nd Ed.)*. Upper Saddle River, NJ, USA: Prentice-Hall, Inc., 1992.

# Paper F

## Distribution Grid Energy Balancing over Heterogeneous Communication Networks

Thomas le Fevre Kristensen, Rasmus Løvenstein Olsen, Florin  
Iov, Hans-Peter Schwefel

The paper has been submitted to in the  
*IEEE Transactions on Smart Grid*

© 2017 IEEE

*The layout has been revised.*

## Abstract

*Distribution system operators may control active power of selected consumers and generators in order to achieve a desired grid behavior. This paper considers a control strategy for this use-case, called energy balancing, and investigates its performance for a realistic grid scenario using a hardware-in-the loop testbed. In the deployed control architecture, the controllers are placed on the substations and interact with the grid-assets via non-ideal communication networks. Via communication network emulation and via the use of simulation models, the impact of imperfect communication on the grid behavior is investigated.*

## 1 Introduction

With the expected increase in decentralized energy resources, primarily from wind and photovoltaics (PV), electrical grids are exposed to new load and production scenarios that they were not originally designed for. Furthermore, new high consumer demands from Electrical Vehicle (EV) mobility and heat pumps challenge existing distribution grid infrastructures additionally. As a result, there is an increased interest in technologies to improve the operation of the grids. These mainly entail local energy storage, active control of energy fed into the electrical grid, flexible demand control (entailing both end-user managed demand response and autonomic demand control) for house-holds and EVs as well as flexible power production and consumption in Medium Voltage (MV) grids.

The focus of this paper is on the impact of non-ideal communication networks on automation and control approaches required for such future distribution grids, which enable Distribution System Operators (DSOs) to utilize the flexibility of the aforementioned grid assets in order for the distribution grid to follow a desired total power reference. We call this control use-case in this paper subsequently 'energy balancing'. The coordination of control actions happens hierarchically starting from a central entity, Medium Voltage Grid Controller (MVGC), which takes inputs and measurements from the medium voltage grid to calculate new setpoint references for the medium voltage grid assets. At the next level in the hierarchical control approach is the Low Voltage Grid Controller (LVGC). This takes a reference setpoint from the medium voltage grid controller as input along with measurements of the low voltage grid state in order to operate the assets within the particular distribution grid. A single medium voltage controller may thereby interact with several low voltage grid controllers in addition to other medium voltage assets.

All these control operations are relying on the ability to communicate measurements and setpoints between the controllers and the assets. Due to

# 1. Introduction

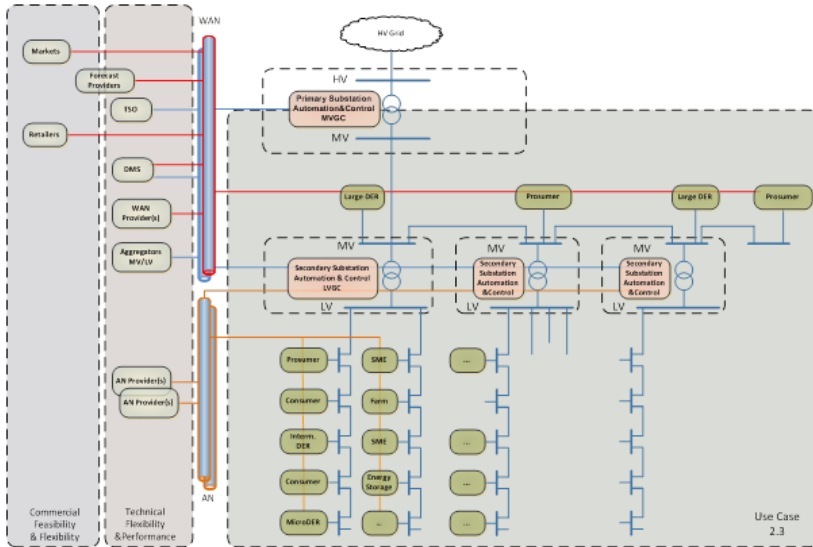

Fig. F.1: Deployment context for energy balancing.

the heavy investments otherwise required by the DSO in deploying their own communication network, we study in this paper the possibility to re-use existing, third party, general purpose networks, which share the distribution grid communication with other data traffic types and thereby show a stochastic delay behaviour and possible packet losses.

The goal of energy balancing is enabling LV and MV grids to follow a power reference via the control of distribution system assets. Such control can reduce grid (over-)load situations and reduce losses. Further it is an enabler of future services such as partially autonomous micro-grid operation. The performance of the energy balancing solution however needs to be evaluated in the context of realistic grid scenarios. This paper therefore describes the implementation of an existing energy balancing controller [1] in a hardware-in-the-loop (HIL) testbed and subsequently investigates the performance of the energy balancing controller for a realistic grid scenario. The testbed allows to analyze scenarios of ideal communication (with negligible delay and no loss) and subsequently compare to non-ideal communication scenarios at a very high technological readiness level due to its model accuracy and resolution. Furthermore, the paper assesses the performance bounds at which non-ideal communication network behavior significantly affects control performance. The paper therefore contributes to an understanding of the requirements on the communication networks in order to support energy balancing in smart distribution grids.

Energy balancing has been investigated in simulation models in [1, 2].

This paper uses the same control architecture and the same controllers, however the HIL testbed provides a much more detailed and fine-granular grid model and includes the actual communication protocol realizations in physical entities. Simulations were so far also the main instrument to analyze the impact of imperfect communication on other control use-cases: [3] considers the scenario of a wind-farm controller, [4] simulates the usage of electric vehicles in a vehicle-to-grid scenario, and [5] investigate the impact of communication outages on Demand Management schemes. Several different controller designs have been studied, e.g. in [6] and [7], however with the focus on controller design and therefore often assuming perfect communication network conditions. Finally, different smart grid evaluation tools exist; [8] provides an overview of many of these, and also details the accuracy advantages of the HIL approach as opposed to pure simulation tools.

Section II introduces the energy balancing use-case and its key performance indicators (KPIs). Section III introduces the control architecture and describes the used controller from [1]. Section IV describes the testbed realization, the emulation tools used within the testbed and the supporting simulations setup. Section V presents the results from the testbed analysis on the effectiveness of energy balancing both in an MV and LV grid and subsequently presents a detailed analysis using the combination of the testbed and simulation tools of the impact of the communication network performance for communication to LV assets.

## 2 Energy Balancing in Medium and Low voltage grids

The use case which is in scope here is illustrated in Figure F.1. The figure illustrates in the center several secondary substations which connect to the LV grids in the bottom that contain variety of consumers of different types and also smaller electricity generators. The secondary substations connects these LV grids to a MV grid which in turn is connected by a primary substation to the HV grid on top. The MV grid contains larger DERs and larger consumers. The primary substation can interact via a Wide Area Network (WAN) with assets in the Medium Voltage Grid and with other stakeholders and external systems, shown in the upper left part of the figure. The secondary substations are themselves assets in the MV grid and therefore are also reachable by the WAN. Furthermore, the secondary substations will interact with some of the LV grid assets via another communication network, here called Access Network (AN). The latter may be of heterogeneous type and the potential non-ideal properties of this network will shape a large part of the analysis later in this paper.

Considering that renewable energy resources are introduced in the LV



## 2. Energy Balancing in Medium and Low voltage grids

and MV grid, new problems arise and are challenging the grid operation. The new types of energy resources challenge in particular the voltage profiles across the low voltage feeders, due to production of power that is not coordinated to the local demand. Operating a grid without any control also implies possible high loss of energy due to non-optimal or un-coordinated operations of the renewable energy resources. Further, the existence of certain load characteristics as well as the option of not producing maximum power at the renewable energy resources offers some flexibility which may be helpful to support grids at higher levels.

Therefore it is desirable that the the low voltage and medium voltage grid would be able to: 1) maintain a specific voltage profile along the feeders, 2) keep grid losses at a bare minimum; 3) keep infrastructure and operation costs of the energy distribution grids as low as possible and 4) aggregate the flexibility of the assets such this flexibility can be used effectively to support the grid operation elsewhere in the grid. In order to achieve this, we consider the introduction of a networked control system that is able to control the assets in the electrical grid. The focus in this paper is thereby the reference tracking capability, i.e. the ability of the MV or LV grid to follow a setpoint. Other control objectives include voltage variations and voltage dips/swells, see [G] for a more detailed analysis of the latter.

We thereby assume that there are several flexible assets in the distribution grid, which shall be able to receive and follow an admissible setpoint for active power from upper hierarchical controller(s). Note that in contrast to Demand Management and Demand Response schemes [5], there is no energy price and market involved in the control loop in this paper; the scenario of this paper for instance results, if the DSO directly interacts with some of the flexible assets itself, e.g. via specific contracts with the asset owners in order to support the reliable and efficient operation of the distribution grid. All flexible assets in the MV/LV grids shall be able to send information about current active power production to upper hierarchical controller(s).

The resulting hierarchical control architecture and the used controllers are described in more detail the next section.

As the focus of this paper is the energy balancing functionality and its sensitivity to non-ideal communication network behavior, we here introduce the rationale for three KPIs which later drive the evaluation:

1. Reference tracking error: Indications on the grid's ability to follow a set reference using flexibility from the assets in the grid.
2. Access network packet loss limit - An application layer packet loss probability below this boundary shall not lead to a significant increase in tracking error.
3. Access network delay limit -An application layer packet delay that is

lower than this boundary shall not lead to a significant increase of the tracking error.

These KPIs are quantitatively investigated later in Section 5.

### 3 Control architecture

The energy balancing use-case considers a MV and LV grid with a variety of assets, of which some are controllable and some are not. In order to realize the energy balancing functionality, we investigate a two-level control hierarchy, illustrated in Figure F.2. The Medium Voltage Grid Controller (MVGC) is placed on the primary substation and can access the local substation measurements and furthermore interacts with the subset of controllable assets in the MV grid. Among these assets is a Low Voltage Grid Controller (LVGC), which is placed on the secondary substation and controls a subset of assets in an underlying LV grid. The MVGC and the LVGC are both energy balancing controllers, with the main function to ensure the total consumption of its underlying power grid follows a reference given by the controller on the voltage level higher than itself. For the LVGC, this reference is given by the MVGC, while the MVGC receives its reference from the Distribution Management System (DMS); the process on how this MVGC reference is obtained is outside the scope of this paper. The functionalities provided by both the MVGC and LVGC are:

1. Active power control: the controller shall be able to control active power on the higher-level side of its substation. The active power control shall be made using the reference from the higher layer, the current measured active power at the substation, the measured active power from a subset of controllable assets in the corresponding part of the grid, and the total available power from the controllable assets in the grid. The output of the active power control shall be a reference signal (power value in kW) for all controllable assets connected to the outgoing feeders.
2. Active power dispatch: the controller shall be able to distribute the reference signal from active power control to controllable assets in the feeder as individual setpoints for active power. The individual setpoints for active power shall take into account actual power production and availability from the flexible assets. These individual setpoints contain active power values in [kW].
3. Aggregation of available active power: The controller shall be able to aggregate the available active power and communicate it to the higher level.

### 3. Control architecture

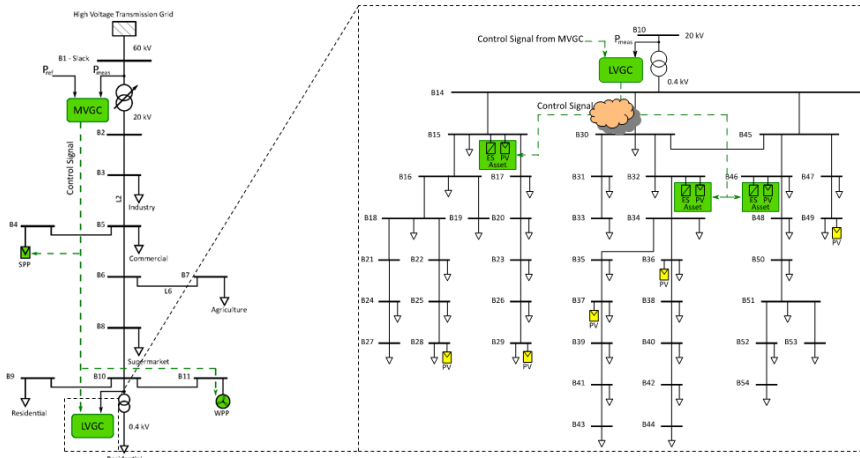

**Fig. F.2:** Hierarchical control architecture visualized within a Danish example grid that is used later in the analysis

Both controllers operate periodically, with control periods in the order of several minutes; the scenario later uses as base case a control period of 1 minute for the MVGC and 15 minutes for the LVGC. The control algorithms are described in [9] and are summarized here in the following.

**MVGC algorithm** The energy balancing algorithm in the MVGC consists of both feedback and feedforward controls, in addition to a dispatch algorithm. The feedforward is based on a prediction of future power consumption, which is calculated by a Kalman estimator with a periodic model [9]. The data based on which the model was developed is available in the developed MATLAB toolbox DiSC [10]. To follow the power reference, the controller dispatches set-points to the available controllable assets. The dispatch is computed by solving a simple convex optimization problem, which ensures that the control algorithm can be executed on a MVGC with limited computational resources. Details on the controller design can be found in [9].

**LVGC algorithm** The LVGC applies a PI controller followed by a fairness dispatch strategy identical to the power sharing strategy in [11]. Variants of this controller for microgrid scenarios are described and analyzed in [12].

The considered controllers are controlling assets distributed throughout the power grid, and communication is therefore essential for proper control functionality. As input for the controllers to determine set-points for the assets, all controllable assets within the relevant part of the grid send the information about currently produced active power and available power to the

controller. As the controllers are assumed to be physically co-located with the corresponding substation, the total power consumed by the grid can be measured and accessed locally in addition. The state of the assets will, however, have to be communicated via a communication network to the controllers periodically. We here assumed that this communication is done with the same period as the controller is operating. The controllers will similarly calculate set-points periodically and communicate them to the relevant assets. This communication will be done via an IP protocol stack, so that the communication can take advantage of the already well established ISP networks. The use of IP technology furthermore allows to use different heterogeneous lower-layer technologies. In order to avoid the additional delay and overhead from reliable transport layer protocols, the communication on top of the IP layer uses the UDP (User Datagram Protocol) and the assumption is that both asset status and setpoint messages are using unicast and a single IP packet is sufficient to carry the necessary message content.

We will in this work focus on the analysis of different communication technologies as well as variation of end-to-end network delay and packet loss probability as main impacting factor on the reference tracking capability of the controllers.

## 4 Evaluation Methodology and Evaluation Scenario

To evaluate the energy balancing control performance over heterogeneous communication networks, the system is implemented in an experimental test setup shown in Figure F.3. The experimental setup is divided into three parts; the power grid simulation, the network emulation, and the controllers.

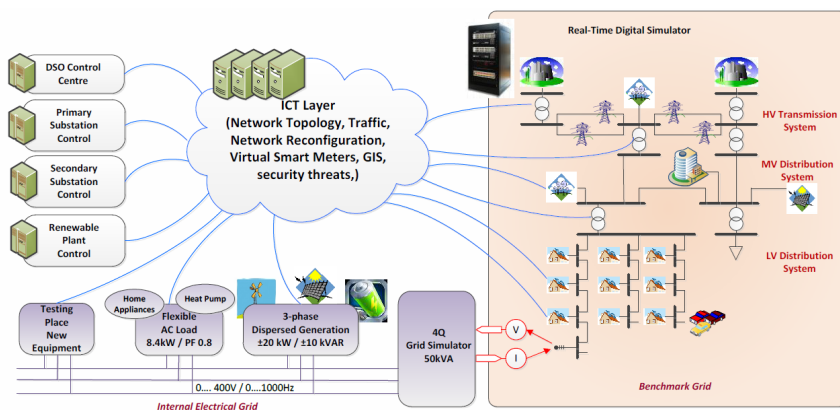

Fig. F.3: Conceptual overview of the experimental test setup.

The electrical grid is simulated in a real-time digital simulator. This simu-

#### 4. Evaluation Methodology and Evaluation Scenario

lator executes a model for the electrical grid, as well as models for each asset in the low and medium voltage grid. Even though this is done in real time, the simulator is capable of simulating the power grid at a 10ms resolution. The controllers are placed in separate PCs to ensure any communication between controllers are also transmitted on the communication network allowing it to go through the communication network emulator imposing delays and losses [13]. Periodically, the state of the assets in the low and medium voltage grid is sent to the controllers, which then compute new set points according to their given reference signals. The two controllers, LVGC and MVGC, are located on separate PCs and will receive the asset states as well as the total grid consumption from the grid simulator via the network emulator. The calculated set points will be sent via the communication network emulator to the individual assets in the electrical grid.

The reference scenario that is used for the analysis is shown in Figure F.2. It consists of an MV grid with 10 20KV buses containing one secondary substation, 5 large inflexible loads in addition to a controllable large Solar Power Plant (SPP) and a large Wind Power Plant (WPP). The WPP model is obtained by scaling the power rating of a single wind turbine. The wind turbine is modelled as a first order system with a variable gain from wind speed to electrical power. Phenomena such as wind shear and tower shadow are neglected in the wind model, in addition to fast fluctuations in the wind speed, see Sect 9.1.1 of [14]. The SPP model is obtained by scaling the power rating of a single photovoltaic system, see Sect 9.1.2 of [14]. For simplicity, it is assumed that a received setpoints from the MVGC will curtail the generation of the SPP and WPP and hence lead to a generated power which is the minimum of the received set-point and of the available power according to the model described before.

The analysis in the next section will consider one LV grid, enlarged in the right part of Figure 4.1. The LV grid contains 48 buses connecting residential households. Three controllable assets are part of this LV grid; these are visualized in Figure F.2 as a combination of Photovoltaics and storage and highlighted in green in the figure. Regarding the asset models, the low-voltage grid assets are implemented in the testbed and in subsequent simulations by models which are described in [1] and are shortly summarized in the following: The assets offering flexibility are seen as ideal, meaning that they follow the set-points that are communicated by the LVGC, as long as the setpoint is within the fixed constraints given defining the maximum and minimum value of active power output. The assets are kept simple as focus is to assess the impact of the interplay between LV and MV grid and the impact of the communication network behavior. The non-flexible assets are modeled by real consumption profiles of Danish households and by PV generation models which are both described in [10].

The communication between controller and assets uses UDP sockets and

Cross-Traffic Level	none	5 kb/s	6kb/s	7 kb/s
Min delay (ms)	109	128	809	1222
Mean delay (ms)	118	160	1509	1788
Max delay (ms)	183	559	2030	2495
Packet loss rate	0	0	74%	91 %

**Table F.1:** Properties of narrow-band PLC for periodic communication with different cross-traffic levels, measured in a lab testbed [1]

the asset status and setpoint messages are contained within a single UDP message with payload sizes 94 Bytes and 54 Bytes, respectively. Network emulation is integrated in the data path between the physical entities (controller PC's and the real time grid simulator), where packets are being routed through the network emulator device to be exposed to delays and packet losses according to specifications, where after data packets are expedited to its actual target. Due to the network routing configuration, communication delays and packet losses can be imposed without changing the communication setup in the grid simulator and controllers. Imposing these network characteristics is done based on measured network delay and loss traces from narrow-band Powerline Communication (PLC) from a lab testbed, in which UDP communication over the different communication network technologies has been measured with different cross-traffic conditions. The key characteristics of these measurements are summarized in Table F.1, see [1] for further details.

Due to the fact that the experimental setup is running in real-time, only a limited amount of tests can be conducted within a reasonable amount of time. Therefore, a simulation study is performed as well to support the experimental results, which allows for the analysis of statistical significance of results based on independent replications and confidence intervals for the mean estimators. These simulations are done using the DiSC tool [10]. This simulation framework will run the same models as the experimental setup, however, the grid emulation is executed based on simplified models from [10] at a lower time resolution of 1 minute.

The tests will be assessed based on the system's ability to balance the energy consumption targeting a given reference. This reference tracking ability is quantified as the root-mean-square error between the reference and the consumed active power.

$$Q_{ctrl} = \sqrt{\left(\frac{\sum_i (P_{ref,i} - P_{meas,i})^2}{N}\right)}$$

In order to quantify the behavior of the energy balancing controller when

the asset communication is subject to delays and losses, we use the ratio between the tracking error as resulting from the current communication scenario and normalize it with the tracking error that is achieved in the same scenario but with ideal communication. For most controller designs, the ratio is expected to be larger than 1, showing the degradation of controller performance in comparison to the ideal communication case.

## 5 Evaluation Results

As the main objective of the controller is to enable reference tracking we provide the MV grid a reference signal to track, and observe the resulting ability of the controller to follow this reference.

### 5.1 MV grid reference tracking

The behavior of the MV grid is illustrated in Figure F.4, where the medium voltage grid controller is asked by the higher-layer grid functions to follow a step-function during the day. Based on this target reference and based on the actual consumption and generation in the MV grid, the MVGC calculates new set points for the MV assets, including also setpoints for energy balancing for the LV grid, which is analyzed in later figures. The MVGC calculates new setpoints with a period of 1 minute. For Figure F.4, the MVGC communicates with the MV assets via an Ethernet communication network in the HIL testbed, which leads to message delays in the microsecond range and does not cause any message losses; therefore this Ethernet case is subsequently used as a good approximation to the ideal communication scenario.

For this close to ideal network performance, numerically, the tracking error sums to 214kW with a standard deviation of 61.5kW as listed in Table F.2. This tracking error is also impacted by the time period between approximately 16:30 and 19:00hrs in Figure F.4, where the assets in the MV Grid do not provide enough generation capability so that the desired reference value cannot be achieved.

Figure F.5 shows the actual asset behavior for a PV plant and and Wind Power Plant in the MV grid. The blue lines show the maximum power that the plants can potentially produce at the certain time instance as resulting from the solar irradiation and wind speed. The lower lines in the figures show the actual production that results due to the received set-points from the MVGC using close to ideal Ethernet communication. Only minor deviations are observed between the two different communication scenarios and these are a consequence of variability of the asset behavior.

As the focus of the analysis of the impact of imperfect communication networks on control performance is put on the communication between LVGC

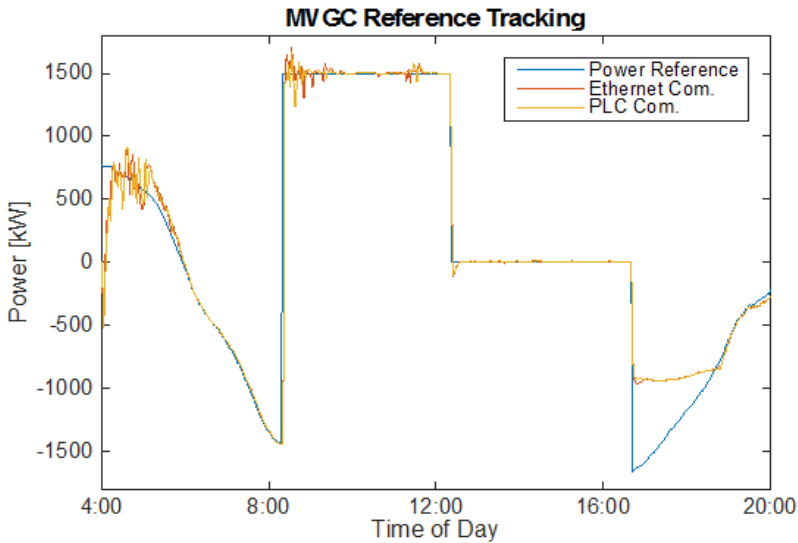

**Fig. F.4:** MVGC reference tracking capability when using an Ethernet communication network which has close to ideal properties (negligible delay, no message losses).

and LV grid assets in this paper, here we only report one experiment, in which the Ethernet communication between MVGC and MV assets is impacted by emulated delays and loss patterns. Despite PLC not being in the candidate set of relevant technologies for MV communication, we used traces from a real narrow-band PLC link without cross-traffic (see first column of Table F.1) in order to check for the impact of such delays: The resulting curves are shown in Figure F.4 and F.5; the figures together with the summary of the quantitative values of the tracking error in Table F.2 show that the tracking error in the MV grid is not negatively affected by the PLC delays in this case; the actual observed value even reduces slightly to 210kW but this is not a statistically significant change, so only caused by stochastic variability of the asset models in the HIL testbed.

## 5.2 Testbed analysis of LV tracking capability

The MVGC also computes setpoints to the connected LV grid, which the LVGC via its asset in the LV grid attempts to follow. For that purpose, the LVGC executes a control loop every 15 minutes. The resulting reference signal received by the LVGC is shown in Figure F.6, which shows in the upper figure the case with near ideal communication between the controller and the asset. Numerically here the tracking error adds up to 8.31kW with a standard deviation of 0.82kW, however, even at the dip at around 17:00 to 19:00 hrs, the



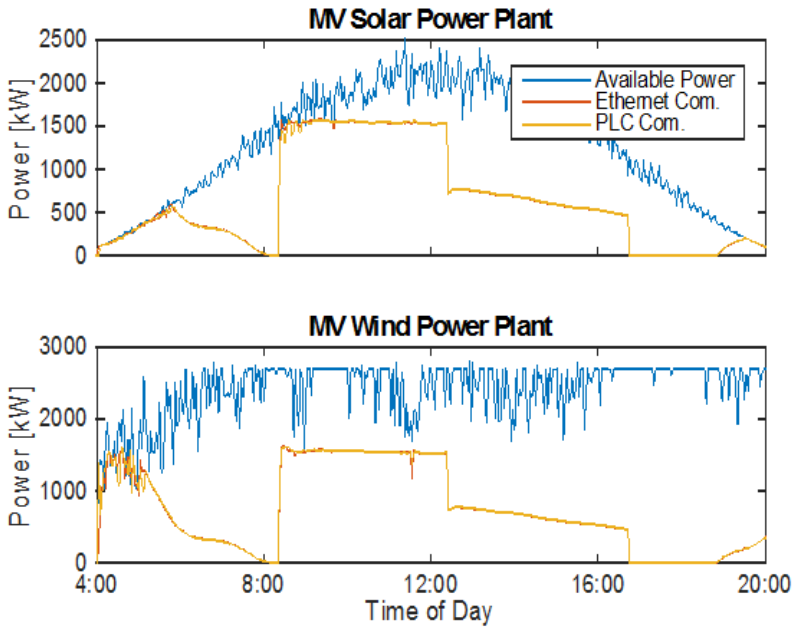
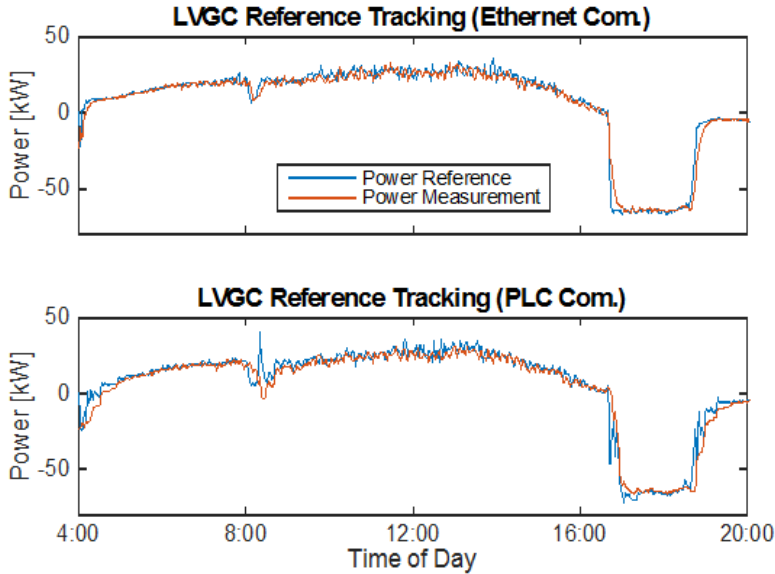

Fig. F.5: Asset set point tracking and potential power production for the PV and wind turbine in the MV grid.

LV grid controller follows reasonable well. When applying communication delays (PLC delay without cross-traffic) some deviations can be observed, effecting the resulting mean tracking error which becomes 8.40kW (with a standard deviation of 1.05kW), so a slight decrease in tracking performance results leading, however with still negligible relative impact, leading to just a 1% degradation compared to the near-ideal case. The discussed results for the overall metrics are summarized in Table F.2.

### 5.3 Sensitivity to high communication delays and losses

The results so far compared narrow-band PLC communication with near ideal Ethernet communication. The PLC links were thereby assumed to be lowly loaded, so the resulting delays were not yet significantly influencing system performance under energy balancing. The performance of PLC links, as well as other communication links, however will be influenced by increasing cross traffic. Reference [1] reports delay and loss results from testbed measurements of different communication technologies when subject to heavy cross-traffic load; Table F.1 summarizes the PLC behavior in these measurements. These measured delay and loss traces can be used in the HIL testbed, however, in order to investigate statistical significance, multiple in-



**Fig. F.6:** Reference tracking capability of the LV grid controller with and without PLC communication in between.

dependent replications need to be executed, and the effort in the testbed will become high, as the testbed needs to be executed in real-time. Therefore, we now move to simulation experiments using a Matlab based simulation framework for the same grid setting with similar asset models [10]. In order to speed up the evaluation, the simulation of the grid model is executed at 1 minute intervals and we subsequently investigate the impact of long message delays and substantial packet loss of the communication between LVGC and LV assets on grid behavior, when subject to energy balancing control. Such large delays may for instance result from narrow-band IoT communication technologies [15], where furthermore duty cycle limitations for the un-licensed band transmissions add to delays. Other scenarios may include cases of malicious attacks on the communication network, for instance a DoS flooding attack as analyzed in [16].

In order to obtain insights into the behavior and reduce the stochastic variability, we start by investigating deterministic delays and assume a deterministic control period of 1 minute. Figure F.7 shows the normalized (with respect to the system when control is executed over ideal networks) tracking error caused by such delays, and as it is seen it actually takes some significant amount of time before the controller is severely impacted, and in this case only after between 6 and 7 minutes, or 6 and 7 control cycles (as the controller operates with one minute control cycle). For delay values of 7 minutes

## 6. Conclusion and Outlook

Energy Balancing	Balancing	MVGC Tracking Error		LVGC Tracking Error	
		Mean	Std. Dev.	Mean	Std. Dev.
Ideal	communication	214 kW	61.5 kW	8.31 kW	0.82 kW
PLC	communication without cross-traffic	210 kW	64.3 kW	8.40 kW	1.05 kW

**Table F.2:** Comparison of tracking ability of energy balancing using different communication networks

and higher, the reference tracking performance degrades by 10-20%. Increasing the delays even further, the energy balancing performance in this case is not significantly affected further.

In the case of increased packet losses (where one packet corresponds to one message from controller to asset or vice versa), we look at a scenario where no re-transmission protocols are deployed (as e.g. when using UDP over IP). The results shown in Figure F.8 indicate quite significant robustness of the reference tracking performance for packet loss probabilities up to 60%. Only from around 70 % packet losses, the controller's impact on the reference tracking is significantly degraded, leading to again degradations between 10% and 20%. In order to illustrate that such high packet loss rates may be observable in high cross-traffic scenarios, the star markers visualize the resulting packet loss rates for PLC with high cross-traffic from Table F.1.

## 6 Conclusion and Outlook

The increasing share of distributed generation in electricity grids creates challenges for the reliable operation of the grids while at the same time providing new opportunities for enhanced observability and control. The communication infrastructure that is used for the interaction with assets, in particular in the LV grid, may be shared and therefore subject to variable communication performance as measured by packet delays and packet loss probabilities. This paper analyzed a use-case targeting referencing tracking of the distribution grid with a 2-level hierarchy of controllers. The system performance of this controller hierarchy is investigated by a Hardware in the Loop testbed that uses real-time grid emulation and enables the emulation of different measured or artificially generated communication network delay and packet loss traces. The testbed results show the effectiveness of the energy balancing

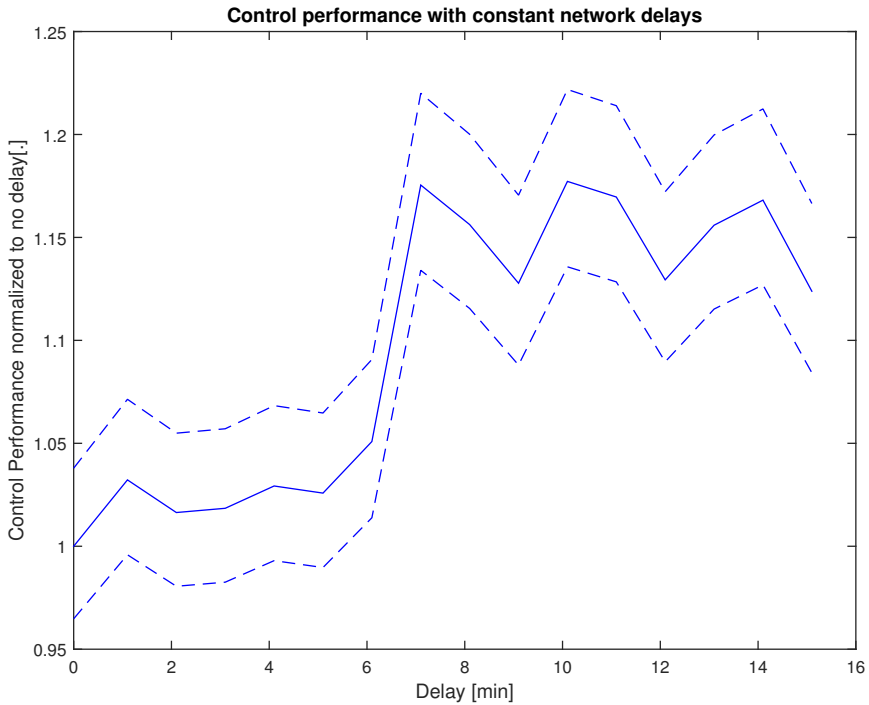
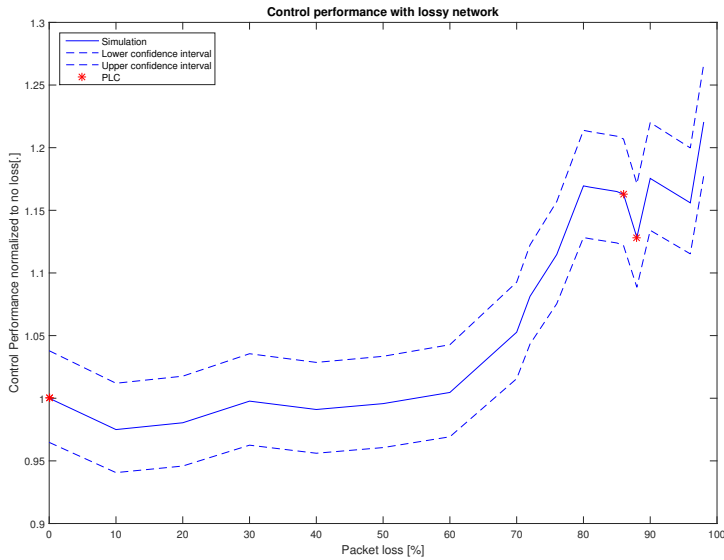

**Fig. E7:** Impact of delay in LV grid controller information feedback system on the tracking error capability

controllers over a close-to-ideal network and they also show that a narrow-band PLC communication network that is in good conditions only marginally impacts the tracking performance. The statistical analysis of simulation results shows that only large delays in the order of multiple control cycles, or packet losses of more than 70% have a significant impact on energy balancing performance.

Future steps involve the extension of the testbed analysis to implementations of recently developed approaches for enhanced robustness of controllers. The latter include the online estimation of communication network performance [2, 17] and the subsequent adaptation of controller gains [12]. Furthermore, the investigations of the testbed can be extended to address the impact of the actual interaction patterns between assets and controller as done in simulations so far in [G] [3].

## References



**Fig. F.8:** Impact of packet losses in LV grid controller information feedback system on the relative tracking error.

## Acknowledgment

This work was co-financed by the SmartC2Net research project, supported by the European FP7 framework programme under grant No318023. The authors would like to thank the consortium partners for the fruitful discussions. In particular, the authors would like to thank Mislav Findrik, formerly Forschungszentrum Telekommunikation Wien, for providing the communication technology measurements, and Rasmus Pedersen and Christoffer Sloth, Aalborg University, for developing and providing the energy balancing controllers.

## References

- [1] M. Findrik, R. Pedersen, E. Hasenleithner, C. Sloth, and H.-P. Schwefel, "Test-bed assessment of communication technologies for a power-balancing controller," in *Energy Conference (ENERGYCON), 2016 IEEE International*. United States: IEEE, 2016.
- [2] M. Findrik, R. Pedersen, C. Sloth, and H.-P. Schwefel, "Evaluation of communication network state estimators for adaptive power-balancing,"

## References

- in *5th D-A-CH+ Energy Informatics Conference 2016*, F. Kupzog and W. Elmenreich, Eds. Springer, 2017.
- [3] J. Madsen, M. Findrik, T. Madsen, and H.-P. Schwefel, "Optimizing data access for wind farm control over hierarchical communication networks," *International Journal of Distributed Sensor Networks*, vol. 12, no. 5, 2016.
- [4] H. S. V. S. K. Nunna, S. Battula, S. Doolla, and D. Srinivasan, "Energy management in smart distribution systems with vehicle-to-grid integrated microgrids," *IEEE Transactions on Smart Grid*, vol. PP, no. 99, pp. 1–1, 2017.
- [5] T. B. ADDED, "Sc2net demand management paper," *Under Review*, 2017.
- [6] S. J. Crocker and J. L. Mathieu, "Adaptive state estimation and control of thermostatic loads for real-time energy balancing," in *2016 American Control Conference (ACC)*, July 2016, pp. 3557–3563.
- [7] A. Lucas and S. Chondrogiannis, "Smart grid energy storage controller for frequency regulation and peak shaving, using a vanadium redox flow battery," *International Journal of Electrical Power & Energy Systems*, vol. 80, pp. 26 – 36, 2016. [Online]. Available: <http://www.sciencedirect.com/science/article/pii/S0142061516000375>
- [8] K. Mets, J. A. Ojea, and C. Develder, "Combining power and communication network simulation for cost-effective smart grid analysis," *IEEE Communications Surveys Tutorials*, vol. 16, no. 3, pp. 1771–1796, Third 2014.
- [9] S. Consortium, "Supply/demand control algorithms," 2015, <http://smarc2net.eu/public-deliverables/>.
- [10] R. Pedersen, C. Sloth, G. B. Andresen, and R. Wisniewski, "Disc: A simulation framework for distribution system voltage control," in *2015 European Control Conference (ECC)*, July 2015, pp. 1056–1063.
- [11] F. B. John W. Simpson-Porco, Florian D"orfler, "Synchronization and power sharing for droop-controlled inverters in islanded microgrids," *Automatica*, vol. 49, no. 9, 2013.
- [12] R. Pedersen, M. Findrik, C. Sloth, and H.-P. Schwefel, "Network condition based adaptive control and its application to power balancing in electrical grids," *To appear in Sustainable Energy, Grids and Networks*, 2017.
- [13] C. Ciontea, R. Pedersen, T. le Fevre Kristensen, C. Sloth, R. Olsen, and F. Iov, "Smart grid control and communication: The smarc2net real-time hil approach," in *Power Tech Eindhoven*, June 2015.

## References

- [14] S. Consortium, "Control framework and models," 2015, <http://smarc2net.eu/public-deliverables/>.
- [15] B. Vejlggaard, M. Lauridsen, H. Nguyen, I. Kovács, P. Mogensen, and M. Sørensen, "Coverage and capacity analysis of sigfox, lora, gprs, and nb-iot," in *IEEE 85th Vehicular Technology Conference*, 2017.
- [16] G. Dondossola, F. Garrone, J. Szanto, and G. Fiorenza, "Assessment of power control systems communications through testbed experiments," in *CIREC 2009 - The 20th International Conference and Exhibition on Electricity Distribution - Part 2*, June 2009.
- [17] M. Findrik, T. le Fevre Kristensen, T. Hinterhofer, R. L. Olsen, and H.-P. Schwefel, "Information-quality based lv-grid-monitoring framework and its application to power-quality control," in *Ad-hoc, Mobile, and Wireless Networks*, ser. Lecture Notes in Computer Science, S. Papavassiliou and S. Ruehrup, Eds. Springer International Publishing, 2015, vol. 9143, pp. 317–329. [Online]. Available: [http://dx.doi.org/10.1007/978-3-319-19662-6\\_22](http://dx.doi.org/10.1007/978-3-319-19662-6_22)



**Thomas Kristensen** was born in Silkeborg, Denmark on the August 18th 1988. He graduated from Aalborg University in 2013 with a masters degree in Networks and Distributed systems with his thesis on network adaptations for smart grid controllers. He continued his studies in this field as a PhD candidate at Aalborg University where he specialized in information quality estimation and the role of this in smart grid control systems.

## References



**Rasmus Løvenstein Olsen** Rasmus Løvenstein Olsen is an Associate Professor at Aalborg University working in the Wireless Communication Networks (WCN) group. Rasmus received his master degree from Aalborg University in 2003 and has received his PhD degree on the topic of Context Sensitive Service Discovery and Context Management with focus on access to dynamic information in 2008. Rasmus' current research focus is on the role of communication networks in smart grid and the impact of networks on remote access to dynamic data of the collection as well as the distribution of information. Previously, Rasmus has previous been guest visitor at National Institute of Communication Technology in Yokosuka Research Park in Japan, cooperating with a team of researchers on next generation network technology.



**Florin Iov** (S '98, M '04, SM '06) received the Dipl. Eng. degree in electrical engineering from Brasov University, Romania, in 1993 and a PhD degree from Galati University, Romania in 2003 with a special focus in the modeling, simulation and control of large wind turbines. He was staff member at Galati University, Romania from 1993 to 2001. Dr. Iov was with Institute of Energy Technology, Aalborg University, Denmark between 2001 and 2009 where he was mainly involved in research projects regarding wind turbines and wind power systems. From 2010 to 2012 he held a position as Power System Research Specialist in Vestas Wind Systems working with new ancillary services for augmented wind power plants. Since 2013 Dr. Iov is with Institute of Energy Technology focusing on research within smart grids.



## References

**Hans-Peter Schwefel** Hans-Peter Schwefel is Professor for Communication Networks at Aalborg University, Denmark, and managing director of the startup company GridData ([www.griddata.eu](http://www.griddata.eu)). In parallel to his position at Aalborg University, he has previously been Scientific Director of the Research Center for Telecommunications (Forschungszentrum Telekommunikation Wien - FTW) in Vienna, Austria in 2008-2016. His research focuses on IP-based communication networks and their applications for critical infrastructures with main interest in performance and dependability aspects. Before he joined Aalborg University, he was a project manager at Siemens Information and Communication Mobile, supervising research projects and responsible for the development of technical concepts for next generation mobile networks. He obtained his doctoral degree in the area of IP traffic and performance modeling from the Technical University in Munich, Germany.



## References

# Paper G

## Information Access for Event-Driven Smart Grid Controllers

Thomas le Fevre Kristensen, Rasmus Løvenstein Olsen, Jakob  
Gulddahl Rasmussen, Hans-Peter Schwefel

The paper has been submitted to the  
*Sustainable Energy, Grids and Networks*

© 2017 IEEE

*The layout has been revised.*

## Abstract

*Control of assets in electricity distribution grids is becoming an increasingly interesting solution to address the challenges from the introduction of distributed renewable energy generation. This paper looks at a voltage control scenario in the low voltage (LV) grid, which targets the reduction of over- or under voltages via the adjustment of reactive power of selected low voltage grid assets. The paper designs and evaluates different interaction schemes between the controller and the remote sensors and assets, focusing on a so-called event-driven control activation and addressing stochastic communication network performance. Two different information quality metrics, information age and mismatch probability, are introduced, expressed via stochastic models, and their suitability for optimization of the implementation of the networked control scenario are investigated. The latter is done by a parametric study in simulation models of these information quality metrics and by comparison of their qualitative behaviour to the overall system performance of the controlled system.*

## 1 Introduction and background

Operation of smart grids involves typically control, coordination of renewable energy resources and/or loads, [1], [2]. As soon as control approaches involve the balancing or coordination of multiple, geographically distributed low voltage grid assets, such control has to collect grid status information and send set points to these using a communication network. For cost efficiency it is desirable to be able to execute the required message exchanges on existing communication infrastructures and therefore, due to the use of narrow-band communication technologies or due to the resource sharing with other communication network traffic, stochastic communication delays and message losses often occur hereby leading to reduced information quality at the controller side, see e.g. [3]. The design of control systems on the other hand frequently considers ideal communication networks [4], [5], or deterministic end-to-end delays between controller and assets [6], which idealises the information quality. In this paper we focus on exactly the link between network performance, access mechanisms to information, information quality and its relation to smart grid control.

Smart grid controllers can be designed to operate periodically, see e.g. the case of energy balancing [F], [7], in which medium or low voltage (LV) grids are desired to follow a certain reference behaviour in their total consumption or generation. In contrast to such periodic controllers, this paper considers the scenario of an event-driven controller and uses the application case of voltage control in LV grids. Grid codes [8], [9], demand that operational voltages are in the range of 10% of the nominal voltage range of the

## 1. Introduction and background

grid. An event-driven control solution for voltage control would not change the asset behaviour in periods when these voltage bounds are not crossed. However, when the voltage in parts of the grids gets close to the demanded bounds, typically indicated by a first set of voltage thresholds that are monitored by sensors or smart meters, sensors or smart meters would then notify the controller about the threshold violations and the controller would then be activated and start calculate new set points for controllable assets based on the current state of the grid, which continuous periodically until the voltage is within the set voltage boundaries.

In this paper, we investigate the impact of a non-ideal communication network on different strategies for grid information collection process that supports an event-driven voltage controller. A periodic proactive strategy for grid information collection is compared to a reactive strategy, which only accesses grid related sensor information after the trigger event for the controller has been received. A resulting trade-off between information quality and response time of the controller has already been identified in [D]. This paper is extending the previous analysis by also analysing the resulting system performance using the example of an voltage event-driven triggered droop controller in a coordinated setting.

Any system which requires access to dynamic information over a communication network (or anything that causes delays in the exchange of the information) will potentially suffer from information mismatches, that is, the information when being used is not matching the value at the source due to external events forcing the observed system into new states with application dependent consequences. Traditionally, the age of information is used as an indication of how useful the information is for the consumer e.g. a controller, [10], [11] or [12] for a more generic discussion use of network QoS in relation to smart grids, however, all with their limitations when it comes to quantifying information mismatches. Taking a time stamp at observation time at the sensor, attaching to the information and sending it at some point (either when controller requests it or upon a forced update notification) does not say much about the validity of the information when being used to make a control decision. Our previous research [D], [13], showed that access method, end-to-end delay as well as the dynamic aspect of the information that jointly impacts the probability of mismatches can be modelled in order to quantify the probability of mismatches, the so-called mismatch probability (mmPr). In this work, it has also been illustrated the strength of combining information and network properties to perform trade-off in e.g. QoS setting and protocol configuration (e.g. update rates [13], or caching times, [14]) which otherwise is not doable or normally done by some heuristics. Based on those experiences we consider a similar approach a given control approach

can be used effectively to make decisions on the network and protocol configuration such that network resources can effectively be allocated for the event-driven smart grid controller.

MmPr has previously been used to analyse periodic controllers [15], and energy balancing [3], however in contrast to previous work, this paper focuses on the event-driven controllers that have first been addressed in [D]. A coordinated approach to voltage control has been investigated in [16]. The latter work has however not addressed the impact of the communication network and of the information access strategy.

Section II describes the control architecture and the case study that is used throughout the paper as well as introducing the key KPI for the electrical grid in which control performance and impact of network is measured against. The section also provides initial simulation results for a non-controlled scenario as a base line case. Section III introduces the two schemes for information access at the beginning of the control period, a reactive one and a periodic one; it then introduces the two information quality metrics, information age and mismatch probability and derives mathematical models to calculate these metrics. That section furthermore shows example results for the voltage control case study which demonstrate qualitative differences between the two information quality metrics. Section IV introduces the specific controller and shows simulation results analyzing the voltage quality KPI under ideal information access and ideal setpoint communication, i.e. without any resulting delays. Section V then analyzes the control system under non-ideal information access for the different information access schemes and varying communication network delays. It then compares the results of the KPI analysis with analytic and simulated information quality metric results, deriving conclusions on the usefulness of the different metrics for optimizations of the control system.

## 2 System Architecture and Case Study

Now we introduce the general control approach and communication architecture and in addition the LV grid scenario that is guiding the numerical evaluations and simulation analysis in later sections. The specific voltage controller realization is only used later in Section V and therefore only specified later in that section.

### 2.1 System Architecture

The overall control architecture assumes that there is an computational entity available co-located to the secondary substation which can perform volt-

## 2. System Architecture and Case Study

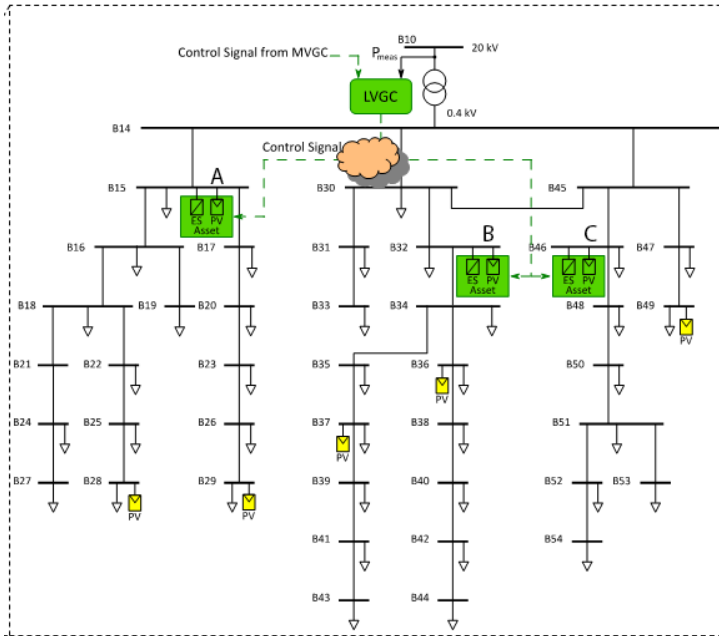

**Fig. G.1:** Control and communication architecture visualized on top of an example low voltage grid with three controllable assets. The evaluation results in later sections focus on the three buses marked with A, B and C.

age control, called Low-Voltage Grid Controller (LVGC). We assume the controller therefore has access locally (via the substation network) to measurements of the total power and voltage at the LV bus-bar of the secondary substation. The controller receives notifications of threshold crossings of voltage values from different sensors in the LV grid, more specifically at Bus A, B and C shown in Figure G.1. Furthermore, the controller can communicate to a subset of controllable assets in the low-voltage grid: these assets send their voltages and power flexibility to the controller, which in turn can decide on set points for reactive and active power. This control architecture is illustrated in Figure G.1 for the example of 3 controllable assets marked by green boxes, also located at Bus A, B and C respectively. We assume uni-directional communication between sensors and controller as well as bi-directional communication is possible between controller and controllable assets but that this is subject to variable delays, later modelled by stochastic processes.

## 2.2 Generalized event-driven controller

Since the main focus of paper is on the interactions between controller and controllable assets and related information quality impacted by the network in between, the analysis in Section III will not need the specific controller realization and parametrisation but rather a description of the interaction patterns between controller and assets and sensors. We therefore focus on event-driven controllers, which for the scenario of voltage control implies the following generalized behaviour:

1. The controller is inactive, i.e. does not send any set points to the controllable assets in the LV grid, if voltage is within boundaries given to the controller. This implies an unconstrained operation of the assets according to their local rules, e.g. maximized generation in case of photovoltaic (PV) and application of only local control of reactive power.
2. As soon as any of the LV grid sensors detects a crossing of a configured upper or lower threshold of voltage values, it notifies the controller via a message, and the controller will become active.
3. The controller will then use its knowledge of the LV grid status, which can be obtained in different ways, see Section III, in order to calculate set points to the controllable assets. It will continue to do so periodically until the voltages at all sensors are back in between another set of voltage bounds, i.e. there is a hysteresis between start/stop boundaries.

## 2.3 Evaluation scenario and default parameters

We consider for our case a low voltage (LV) distribution grid shown in Figure G.1, which is an extrapolation of an actual LV grid in continental North Denmark [17]. This grid contains 42 buses, 37 households some with heatpumps and 8 PV of which 3 are controllable. The households consumption patterns are modelled based on consumption data of the actual LV grid, [17], [18] and [19]. The PV generation is modelled based on time of day, geographical location and whether or not clouds cover the PV. Cloud cover is modelled stochastically, for details see [20]. The three controllable PVs are complemented by battery storage and the behaviour of both active and reactive power generated by these joint PV and storage units is assumed to be controllable via set points from the LVGC. Assets are working with local conditions meaning sun and wind may be different at each asset, but will otherwise be assumed to follow given set points perfectly.

Since the LVGC is event triggered it will only be running if a voltage measurement is outside some given voltage bounds. Existing grid codes require voltages to be in range of  $\pm 10\%$  of the nominal voltages [8]. For the evaluations in this paper we use much narrower bounds at  $1 \pm 0.013$  p.u.



## 2. System Architecture and Case Study

to identify voltage violations whereas the thresholds for activating the controller are at  $1 \pm 0.01$  p.u. for the following two reasons: (1) to allow the controller time to react in advance before the actual grid regulation bounds are reached, (2) to allow more frequent control events in order to achieve statistically significant results without excessively long evaluation periods. For the evaluations in this paper, the three controllable assets also act as sensors for voltage threshold crossings. When the controller has been notified about a relevant threshold crossing, it starts operating periodically with period of 2 minutes.

The parameters of the LV grid, of the asset models, and of the generalized event-driven controller are summarized in the following table:

Parameter	Value
Number of electrical nodes	49
Number of buses	42
LV base voltage	400 [V]
PV max rated power	6 [kW]
PV Efficiency	20%
PV Area	28 [m <sup>2</sup> ]
Energy storage capacity	65 [kWh]
Energy storage rated power output	10 [kW]
Simulation day	A day in June (June 9)
geographical latitude	56,889 [°]

Table G.1: Grid model parameters

Although elements are individual we assume that they share the same property values.

### 2.4 Reference grid behaviour without voltage control

The behaviour of the reference grid has been simulated using the grid model described above. Further control related parameters are shown later in Table G.2. The model is run with a Matlab based simulation framework DiSC [19], without any control, and evaluate grid performance based on the number of simulation samples outside of given voltage violation event thresholds.

Figure G.2 shows the behaviour of the voltage at the three locations where the controllable assets are placed. As the variability due to the presence of photovoltaic generation is most interesting to our analysis, we consider a time period starting at 5 am and lasting for 12 hours. The different buses clearly show different voltage variability within this observation period. The results in this figure should first illustrate the grid behaviour when no control

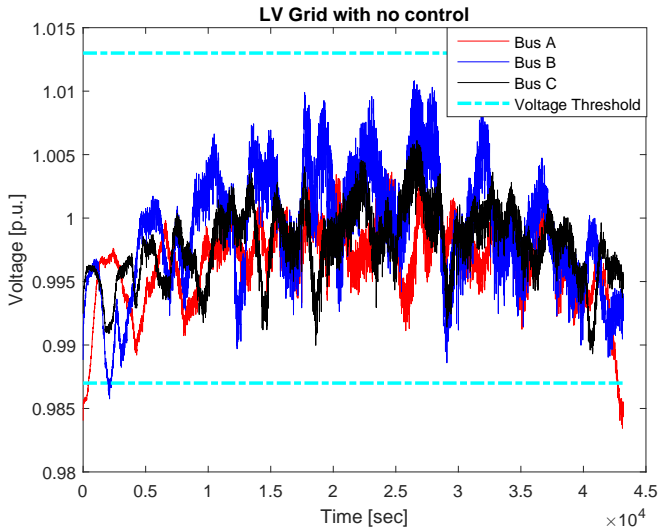

Fig. G.2: Voltages on buses with assets without voltage control.

is applied; secondly, these results are also used in Section III as basis for quantitative analysis.

With voltage violation thresholds of 0.987 and 1.013 for the lower and upper thresholds respectively, the number of voltage events can be counted. The number of voltage events for Bus A is around 180, Bus B around 40 and for Bus C there are no voltage events observed for this run (these can also be seen later in Figure G.11 when we compare number of events when the grid is being controlled).

### 3 Information access schemes and their evaluation

As a prerequisite for control information about the grid first needs to be accessed. In this section we introduce two different schemes that enable the LVGC to have the necessary asset status information from which it calculates set points from. The two access schemes are mathematically analysed using the LV grid that has been described in the previous section.

#### 3.1 Information access schemes

When the LVGC is notified about a voltage threshold crossing by any sensor, it becomes active and has to calculate set points. In order to calculate these set points, the status information (voltage and power) of the controllable assets is required. There are two basic schemes how this information

can be provided to the LVGC, (1) in a reactive manner by requests from the LVGC, or (2) in a proactive manner, where the controllable assets periodically send their status info to the LVGC, independently of the activity periods of the controller. These two schemes have first been introduced in [D] and are described subsequently.

**Reactive access to information**

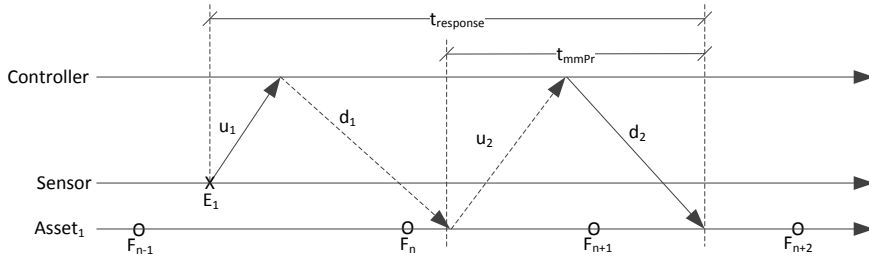
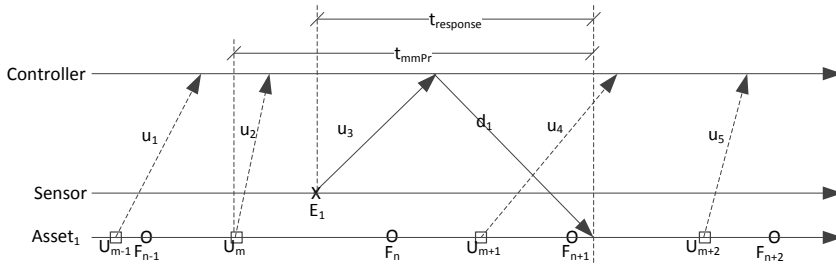

**Fig. G.3:** Message sequence diagram showing the information flow when a voltage threshold is exceeded using the reactive approach to access flexibility information for a single asset.

In the reactive scheme, the controller will ask for information from assets when the voltage event notification have been received by the controller. The message flow in this scheme is shown in Figure G.3 for the case of a single asset: At time  $E_1$ , a sensor node detects a voltage crossing and sends a notification to the LVGC (with upstream delay  $u_1$ ). The controller subsequently requests a status update from the asset, where this request message is subject to a downstream delay of duration  $d_1$ . The asset reads its power and voltage sensors and sends the corresponding values to the LVGC (message with upstream delay  $u_2$ ). The controller uses this status information to calculate a setpoint which it sends to the asset. The setpoint message is shown with a downstream delay  $d_2$ . The time period from the sensor detecting the voltage threshold crossing, until the first setpoint from the controller is executed, here called response time of the event-driven controller, is therefore determined by two bidirectional message exchanges, hence requiring two round-trip time delays.

**Proactive, periodic access to information**

An alternative approach is shown in Figure G.4: The assumption here is that the asset periodically updates the controller with its latest status, visualized by the update moments  $U_{m-1}$  and  $U_m$ . These messages are subject to upstream delays, here  $u_1$  and  $u_2$ . As a consequence of these periodic proactive updates, when any sensor detects a voltage threshold crossing, the LVGC does not need to ask the assets for their status but can instead immediately



**Fig. G.4:** Message sequence diagram showing information flow when flexibility information is accessed periodically independent of voltage events.

calculate the setpoint based on its already present view of the asset status. Therefore, the response of the controller at the start of the event-driven control period reduces significantly, to only one round-trip-time delay (instead of two for the reactive scheme). The cost of this reduced response is however an increased overhead, as all assets always send updates periodically to the controller, even if the controller is not using the information for any setpoint calculation. Details on this overhead analysis can be found in [D].

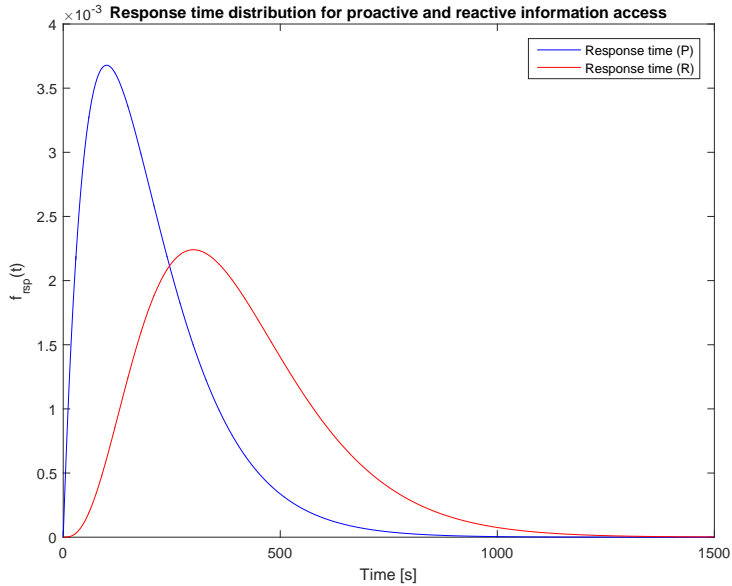

**Fig. G.5:** Numerically computed density functions for response times with all network delays exponentially distributed with a mean of 100s and 120s as the mean time between updates in the proactive scheme.

The probability density function of the response time of the two schemes

is exemplified in Figure G.5: Assumption in this example is that the upstream and downstream delays are identically distributed with an exponential distribution with mean 100s. The figure clearly shows the slower response times of the reactive scheme. We use here a rather large network delay for following reasons: 1) initial analysis shows that only larger delays has an impact worth assessing, 2) the access delays are abstract and hence potentially cover not only communication but caching and other buffer delays in a larger ICT infrastructure supporting such a system and 3) later we use exactly this delay in a parametric study of varying update rate.

### 3.2 Information quality metrics and their calculation

We now introduce two different metrics that allow to quantitatively describe the quality of the input information from the assets that the controller bases its setpoint calculation on. The first one is purely in the time domain and is frequently used for networked control systems:

**Definition:** We define the *information age* of the asset information as the time interval between the moment that the asset reads its status information until it actuates the controller set point that has been calculated based on this asset status.

Note that the age is here defined based on the actuation instant, and not based on the setpoint calculation instant. This is physically meaningful, as only the actuation creates an impact on the physical system, here the reactive or active power of the asset.

The age of the information is shown in the Figures G.3 and G.4 as  $t_{infoAge}$ .

Assuming independent, identically distributed upstream and downstream delays with probability densities  $f_u(t)$  and  $f_d(t)$ , the density of the information age for the reactive scheme for one asset results purely from convolution of these densities:

$$f_{infoAge,rea} = (f_u * f_d)(t). \quad (G.1)$$

For the periodic scheme, the information age also contains a downstream delay. The first part of the information age however, is more complex to calculate, as it also depends on the update period. Assume a periodic update of asset information according to a Poisson process with rate  $\tau$ , the distribution of the time  $w$  between the generation of the last periodic update message and the calculation of the set point by the LVGC can be expressed as the inter-event time of a thinned Poisson process with thinning probability according to the upstream delay distribution (see [13],[D] for the detailed description of

this derivation):

$$f_w(t) = \exp\left(-\tau \int_0^t F_u(v) dv\right) \tau F_u(t), \quad (\text{G.2})$$

where  $F_u$  is the cumulative distribution function of the upstream delay. Subsequently the distribution of the information age results by simple convolution:

$$f_{\text{infoAge,per}} = (f_d * f_w)(t). \quad (\text{G.3})$$

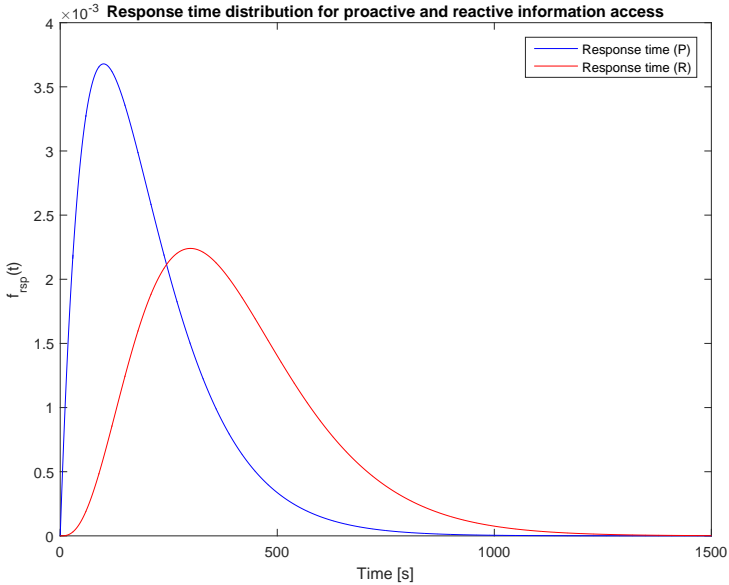

**Fig. G.6:** Density functions for mismatching times with all network delays exponentially distributed with a mean of 100s and 120s as the mean time between updates in the proactive scheme.

Using again an independent identically distributed exponential assumption for the network delays (here with mean 100s), and exponentially distributed updates periods with mean inter-update time of 120 second, Figure G.6 shows the resulting probability density functions of the information ages in the two schemes. Note that the two densities cross multiple times (and not just once as in the case of the response time), so that it is not immediately clear which of the two random variables can be considered ‘worse’. In contrast to that, the moments of the distributions can of course be computed and compared, see later Figure G.7.

The information age is purely depending on the communication network delays, plus in case of the periodic scheme, also on the update period distribution. A difference in the value domain of the measured values, e.g. the

higher variability in some of the buses as observed earlier in Section II, is not influencing the information age as quality metric.

In order to also take into account the behavior of the measurand over time, we use as second metric the so-called mismatch probability, which has first been defined in [13] and applied to different scenarios since then. In the specific case of this paper, we define it as follows:

**Definition:** We define the *mismatch probability* of a specific scalar measurand in the asset information as the probability that the value of the true physical measurand at the time of actuation is significantly lower (or higher) compared to the asset information value that has been used for the setpoint calculation by the LVGC.

Note that the mmPr in this paper is defined with respect to one-sided changes of the measurand. The physical motivation for that is that for many measurands, the use of a wrong value is more harmful, if this value is larger than the assumed one. In the case of undervoltages, which drive the examples in this paper, the more harmful change is actually a deviation to lower values. Therefore, we consider here a mismatch, if the true voltage value at the actuation instant is significantly smaller than the voltage value that has been used by the controller for the setpoint calculation.

The relevant time period for the significant change of the measurand is thereby exactly the time period that is captured by the information age. Therefore, the mismatch probability can be calculated by conditioning on the different possibilities values for the information age:

$$Pr(mm) = \int_0^{\infty} Pr(mm|t)f_{infoAge}(t)dt \quad (G.4)$$

where  $Pr(mm|t)$  is the probability that the information of interest has changed significantly during the time  $t$ , and  $f_{infoAge}(t)$  is the probability density function of the information age as previously introduced.

In order to calculate  $Pr(mm|t)$ , a stochastic model of the measurand is needed. We use a continuous time Markov model in the following, in which a mismatch event is caused if the state of the Markov chain model at actuation instances is smaller than during the moment, when the asset reads its state in order to generate the update message. The Markov chain model is specified by its generator matrix  $\mathbf{Q}$ , from which its steady state probability vector  $\mathbf{f}$  and the transient state probabilities  $p_{ij}(t)$  can be computed as follows:

$$\mathbf{f}\mathbf{Q} = \mathbf{0} \quad (G.5)$$

$$\sum_i \mathbf{f}_i = 1 \quad (G.6)$$

$$p_{ij}(t) = \left[ e^{t\mathbf{Q}} \right]_{ij}, \quad (G.7)$$

where Equation (G.7) uses the matrix exponential function, see e.g. [21]. Using this model, the probability of information mismatch for a given time horizon can be calculated as shown in Equation (G.8).

$$Pr(mm|t) = \sum_{i=1}^M \left( \mathbf{f}_i \sum_{j=1}^{i-1} p_{ij}(t) \right) \quad (G.8)$$

The complete mmPr model can now be written out for each access scheme.

$$Pr(mm_{\text{Rea}}) = \int_0^{\infty} \sum_{i=1}^M \left( \mathbf{f}_i \sum_{j=1}^{i-1} p_{ij}(t) \right) (f_u * f_d)(t) dt \quad (G.9)$$

$$Pr(mm_{\text{Per}}) = \int_0^{\infty} \sum_{i=1}^M \left( \mathbf{f}_i \sum_{j=1}^{i-1} p_{ij}(t) \right) (f_d * f_w)(t) dt \quad (G.10)$$

### 3.3 Application to LV grid scenario

In the following we perform a numerical study of the models developed. We start by analysing the information age, which offers the simplest way of quantifying information quality, and subsequently we focus on mismatch probability, and concludes on the usefulness of these metrics.

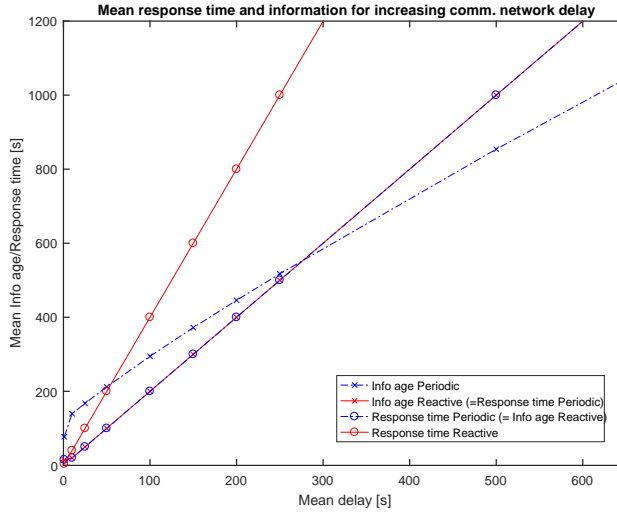

**Fig. G.7:** Mean response time and information age for increasing communication network delays.

Figure G.7 shows the computed numerical results for the mean response times and mean information age for the reactive and periodic cases with vary-



### 3. Information access schemes and their evaluation

ing communication delays. The analysis also takes into account very long network delays, which can result from the use narrow-band communication technologies [3] or from scenarios of frequent transport layer retransmissions due to poor medium conditions or malicious attacks [22]. The update interval for the periodic scheme was thereby set to mean duration of 2 minutes (i.e.  $\tau = 1/120$ ). Obviously, all metrics increase when the mean delay is increasing. The mean response time of both schemes, periodic and reactive, are increasing linearly with the mean delay; the linear growth corresponds to the number of messages needed, 4 for the reactive scheme (notification by the sensor, request for asset information, update message by asset, setpoint communication) while only the first and the last of these ones are needed for the proactive scheme.

The mean information age in the reactive scheme is also growing linearly with the mean network delay, and as two network delays are contributing to it, it is in fact identical to the mean response time of the periodic scheme. The information age of the periodic scheme is not only depending on the network delay, but in addition also the backwards recurrence time to the last received update message is contributing; therefore, even for zero communication network delays at the left end of the figure, the mean information age for the periodic scheme is non-zero. For large network delays, approximately from 300 seconds onwards, the mean information age of the periodic scheme actually becomes smaller than its response times. This is a consequence of the specific independent identically distributed exponential assumptions for the network delays in the scenarios when multiple update messages are simultaneously in transit.

In order to assess the mismatch probability, an information model is required. Here we focus on using a Markov model, for the voltage values in the LV grid from Section II. Hence, we initially fit a continuous time Markov chains to the corresponding voltage traces shown in Section II. In a first step, the voltages are discretised in bins of size 2 Volt with each bin is represented by one state of the Markov chain. Then the empiric transition probabilities are obtained and later translated to transition rates by dividing with the simulation time step. The resulting generator matrix, here for Bus A, is shown in the following:

$$\mathbf{Q}_A = \begin{bmatrix} -0.0073 & 0.0073 & 0 & 0 \\ 0.0006 & -0.0206 & 0.0200 & 0 \\ 0 & 0.0050 & -0.0144 & 0.0094 \\ 0 & 0 & 0.0246 & -0.0246 \end{bmatrix} \quad (\text{G.11})$$

Using these Markov models and the equations from the previous subsections, we are now able to compute numerically and plot the mean values of the metrics *response time*, *information age* and *mismatch probability*.

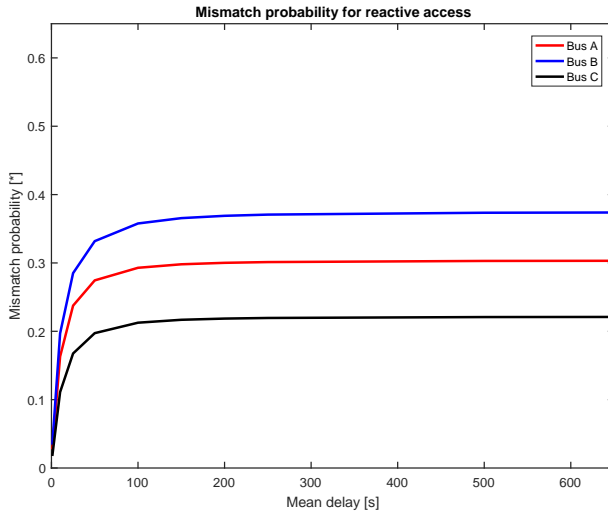

Fig. G.8: Mismatch probability for reactive case for the three buses.

In contrast to response time and information age, the mismatch probability also takes into account the dynamics of the physical measurand, therefore the mismatch probability can be different for different measurement points in the grid. This is clearly visible in Figures G.8 and the subsequent figures, which show the numerically calculated mismatch probabilities for the three different buses, i.e. using different Markov models that are fitted to the corresponding voltage traces from simulations from the LV grid. Figures G.8 shows the reactive case: In contrast to the response time and information age metrics, the mmPr is a concave function and converges for increasing delays to the corresponding steady state probabilities of the relevant states of the Markov chain. The figure shows that there is a strong impact of increasing delays on mmPr in the range up until about 100 seconds. For ideal communication networks, the mismatch probability is 0. This changes for the periodic scheme which is shown in Figure G.9: due to the non-zero update intervals, the mmPr is non-zero even for ideal communication networks. As a consequence, the increase of the communication network delays itself has less impact on mmPr in the given setting compared to the reactive scheme. This however also depends on the other parameter of the periodic access scheme: a decrease of the mean update period will reduce the mmPr at the lower end of the curve (while not affecting the limit value of the mmPr for large values of the delay).

In summary, the numerical results for the mmPr show that this metric has two advantages compared to information age: (1) it allows to identify

#### 4. Voltage Control with ideal information access

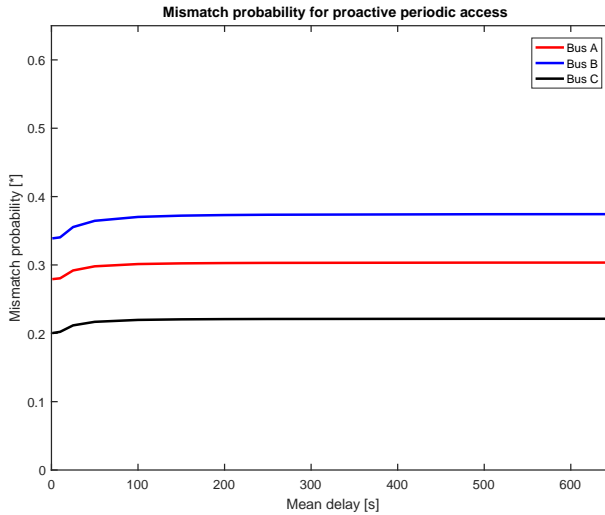

Fig. G.9: Mismatch probability for proactive case for the three buses.

the time-scales on which changes of delays (and, for the periodic scheme, update periods) are relevant in relation to the dynamics of the measured parameter; (2) it can distinguish between different buses. Both advantages will be revisited during the simulations later in Section V.

## 4 Voltage Control with ideal information access

The analysis in Section III focused on information quality metrics, so could be done without specifying the detailed setpoint computations of the controller; all what was needed was the description of the information access schemes and the communication network delays. We now turn our attention to the behaviour of the LV grid, when subject to a controller. The assumption in this section is that the controller can instantaneously access the asset status and also that setpoints are instantaneously communicated to the assets. In this idealized scenario, the information age and mismatch probability (as defined in Section III) are always zero.

This section describes the used controller and provides simulation results for the overall behaviour of the LV grid when subject to this control under ideal information access and ideal setpoint communication. The metric that is used for the evaluation is the number of undervoltage events, so the number of time steps that the actual voltage on a specific bus is below the lower voltage threshold.

## 4.1 Controller implementation

As described in Section II, the controller is started by a voltage threshold crossing events by a sensor or smart meter; the sensor or smart meter will in this case send a message to the controller that voltage has crossed a threshold level,  $v_{Thr}$ . Upon this triggering, the controller starts to calculate and send setpoints periodically to the controllable assets in the grid. The control for each individual asset is a simple Droop control changing only reactive power as follows:

$$u_{Ref_Q}(t) = G_D * (1 - |V_i(t)|/V_{base}) \quad (G.12)$$

with  $V_i(t)$  being the measured voltage at time  $t$  and  $V_{base}$  the nominal voltage, which for the Danish grid in low voltage is 400V. The droop gain,  $G_D$ , for the asset is set to 200.000 for this control scenario. The latter gain has been obtained by manual tuning of the controller for the given reference grid. It is  $V_i(t)$  which is being transported by the network is impaired by the delay and hence, with probability  $mmPr$  falls outside a 2 V range when being used by the controller compared to the real world.

Note that this controller uses local information only to perform control actions, this removes the need for a single centralized controller. However, the controller acts only as example in this paper to illustrate the analyzed issues; more advanced controllers utilizing distributed information are envisioned for future smart grid voltage control [2]. The simple controller considered here is only considered as to not focus on controller design, but rather information access impact.

## 4.2 Simulation Results

We now execute simulations of the LV grid that was introduced in Section II, when running the voltage controller in interaction with the three controllable assets. The analysis is done using the same Matlab based simulation framework DiSC [19], that was already used in Section II. The observed voltage values over time with the voltage controller turned on by voltage crossing events and based on ideal information access and on an ideal communication network are shown in Figure G.10.

The (green) lines in the plot indicate the threshold, which define the voltage crossing events that activate the event-driven controller, see Table G.2 for specific values. Regarding under-voltages, the lower one triggers control start and the upper one triggers stop of the control period. Similarly there are also threshold values above 1 p.u., but since the voltages never reaches values higher than roughly 1.005 p.u. the upper limit never triggers voltage control, and therefore we do not show these here. The threshold values are selected

#### 4. Voltage Control with ideal information access

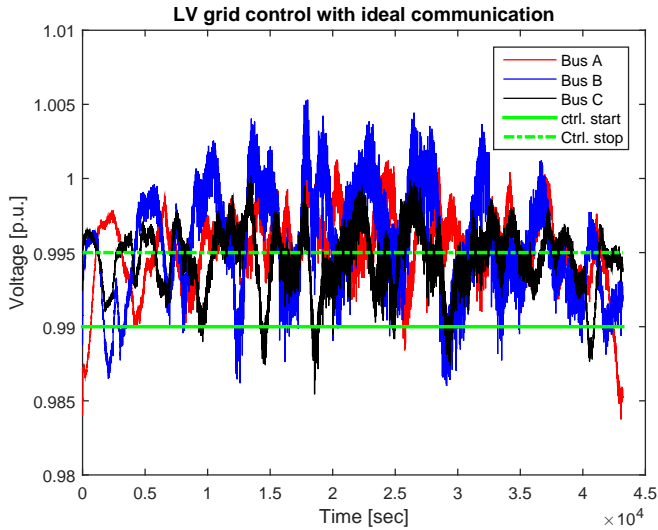

**Fig. G.10:** Voltages on buses with assets with voltage control using ideal information access and ideal communication networks.

quite conservative as already discussed. Further study on the choice of these boundaries potentially involves considering different economic interests is another line of research and not in the scope of this paper.

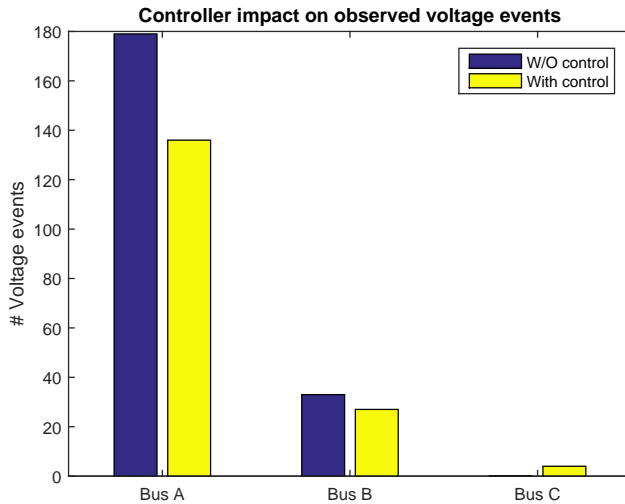

**Fig. G.11:** Voltage bound violations on buses with controllable assets; voltage control uses ideal information access and ideal setpoint communication.

Figure G.11 shows the quantitative comparison of the scenario with voltage control comparing it to the scenario without voltage controller (blue bar/left side bar) that was already illustrated in Section II.. The positive impact of the voltage controller on the voltage quality in Bus A can clearly be seen, while for Bus B and Bus C, a statistically significant improvement cannot be inferred from this single simulation run. A more detailed investigation of statistical significance via confidence intervals obtained from independent replications is part of the next section.

## 5 Simulation analysis of controlled system with non-ideal information access

We now extend the simulation analysis of the previous section to voltage control scenarios with non-ideal information access, specifically including (1) non-zero communication delays for the sensor and asset information (upstream) as well as for the downstream setpoint communication; (2) additional information age caused in the periodic scheme by the caching time of the most recent asset information update at the controller node. These delays will contribute to a degradation of the information quality at the controller as analytically analysed in Section III for the metrics information age and mismatch probability. We will now investigate the same metrics in simulation experiments for the LV grid and compare to the resulting system performance, measured by the number of voltage violations. In order to keep the parameter set low, we thereby use exponentially distributed communication delays with varying expected value as shown in the subsequent table:

### 5.1 Impact of communication delays on reactive strategy

In the first case we study the reactive strategy. Figure G.12 shows the mean estimator and 95% confidence intervals for the numbers of voltage events obtained from 25 independent simulation runs for each (each with different seeds for random number generation). Figure G.12 clearly shows that the amount of voltage events of the three buses is different (as already seen in Section IV) and also the controller shows different sensitivity towards communication delays. As already observed in the scenario of control with ideal information access (reproduced here with confidence intervals at the left end for delay= 0), Bus A in general shows a higher number of voltage events, Bus B an intermediate number, and Bus C a low number of voltage events. Bus A and Bus B show a significant sensitivity to increased communication delays in the range of 0 to approximately 200 seconds for Bus A, and 0 to 600s for Bus B, while Bus C does not show any statistically significant impact of increased communication delays on the mean voltage quality metric; only the

## 5. Simulation analysis of controlled system with non-ideal information access

Parameter	Value
Mean Network Delays	[5; 1200] [s]
Mean update period (periodic scheme)	120 [s]
Number of seeds	25 [-]
Simulation Sampling time interval	5 [s]
Voltage threshold level (for mismatch and control performance)	2 [V]
Control time interval	120 [s]
lower voltage violation event threshold	0.987 [p.u.]
lower start-of-control-period voltage threshold	0.99 [p.u.]
lower end-of-control-period voltage threshold	0.995 [p.u.]

**Table G.2:** Control Simulation Parameters. Upper voltage violation boundaries are not included here as they are not relevant for the specific scenario.

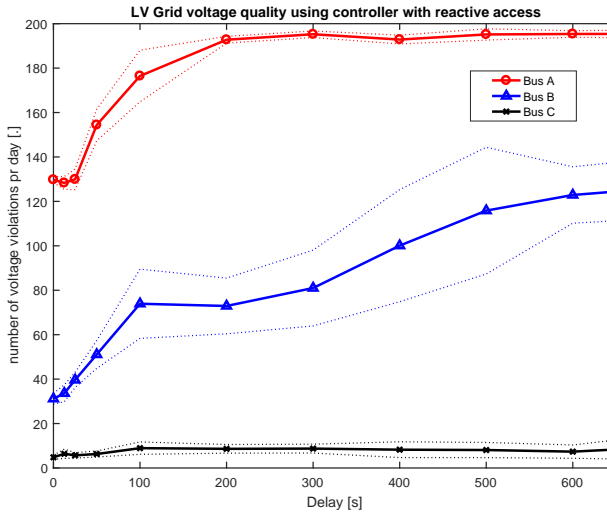
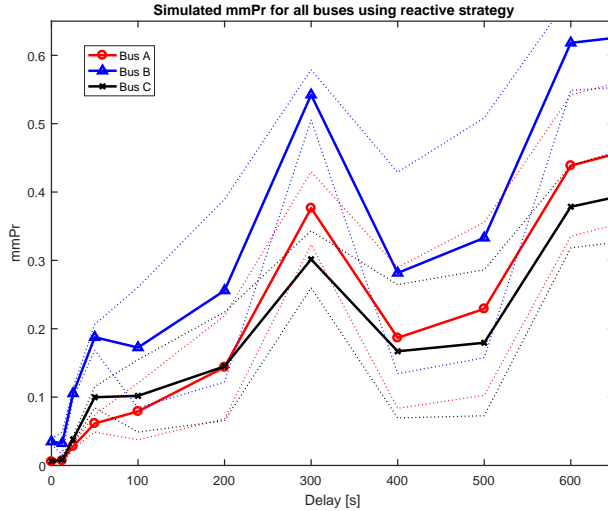

**Fig. G.12:** Simulated Voltage Quality KPI as a function of delay using a reactive access strategy with 95% confidence bands.

confidence interval for the voltage quality metric increases, so an increased variability can be observed.

Regarding information quality, the mean information age in the reactive strategy is always twice the mean network delay, and this strictly linear be-

haviour has already been shown in Figure G.7. The other information quality metric, mismatch probability, however also depends on the time wise evolution of the voltage values at the Smart Meters; as the results in Section III used a Markov model for the evolution of the voltage values, the full grid simulations may behave differently and these results are, therefore, shown in Figure G.13.



**Fig. G.13:** Simulated mismatch probability for the information in the reactive scheme for the individual buses with 95% confidence bands.

The mismatch probability in the reactive scheme is zero for an ideal communication network; the non-zero point on the left for Bus B is an artefact of the discrete time step of the simulations so that any small delay in essence is equivalent to a 5 second delay. The mmPr then raises significantly for all three buses until delays of approximately 50 seconds, hereafter the variability becomes very high, so the confidence intervals are overlapping. The high variability in parts is a consequence of the long response times that result for the reactive scheme for the event driven controller (four times the mean delay, see Section III). For high delays, some of the voltage dips, that cause the controller to become active end already before the controller can become effective, so that way the set points may not be sent out and no contribution to mmPr samples is obtained. We intentionally did not increase the number of repetitions, in order to visualized this increase in variability as opposed to later results for the periodic scheme (which has shorter response times and, therefore, this effect is much less pronounced).

In order to visualize the relation between mismatch probability and volt-



## 5. Simulation analysis of controlled system with non-ideal information access

age quality, we now visualize each simulation outcome for a certain communication network delay from the previous two figures in Figure G.14. The sizes of the ellipsoids visualize the confidence intervals of the simulation estimate of the corresponding parameters. The figure clearly shows the positive correlation between mismatch probability and system performance in terms of number of voltage events for Bus B, while the results for Bus C (due to the insensitivity of the number of voltage events) and of Bus A (due to the large confidence intervals of the mmPr) are less conclusive.

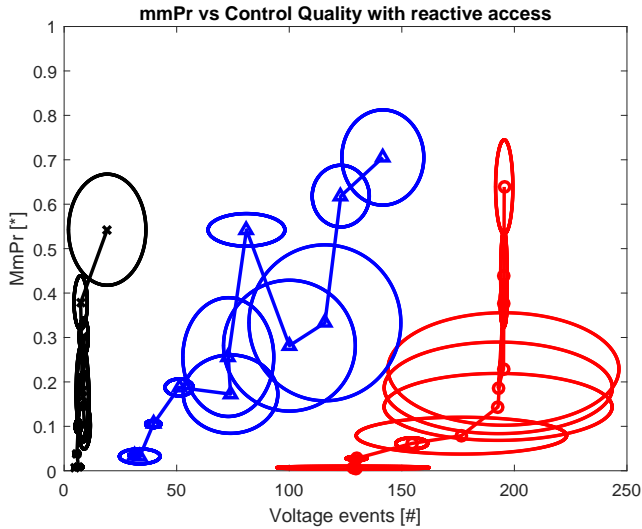
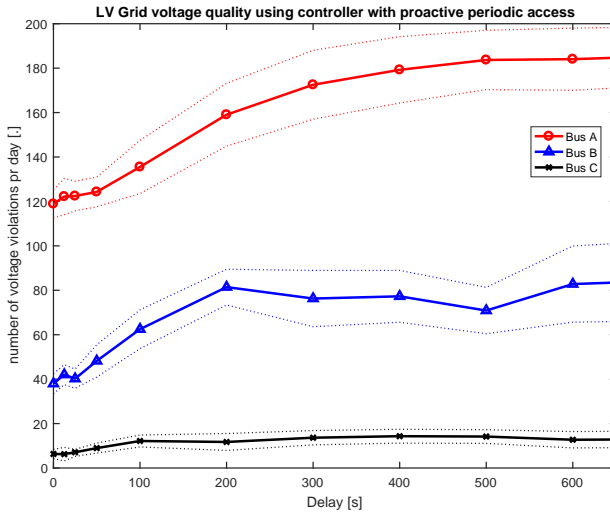

Fig. G.14: Mismatch probability versus voltage events with 95% bounds ellipsoids around simulated results.

## 5.2 Impact of communication delays and update rate on periodic strategy

In this section we focus on the impact of end-to-end network delays on the periodic strategy. These periodic updates are sent by the assets according to a Poisson process with the rate identical to the control rate, i.e. a mean time between update generation of 120 seconds.

Figure G.15 shows the resulting number of voltage events as a function of the communication delay. The left end of the curves shows the scenario of ideal communication networks (with zero delay); due to the discrete time simulation, the point actually reflects a 5 second delays, as smaller values do not show any earlier influence. Note that for the periodic scheme, an ideal communication network does not imply ideal information access, as there is



**Fig. G.15:** Simulated number of voltage events in a voltage control scenario with increasing network delays and periodic asset information update.

still a non-zero information age due to the update interval period, see Section III. Therefore, the left end of Figure G.15 shows slightly worse voltage quality compared to the ideal control in Section V (the seemingly worse result in Section V for Bus A is just a consequence of the statistical fluctuations, as Section V only showed the value from a single simulation run).

The communication network delays have a significant impact on the mean voltage quality for delay ranges of up to approximately 500 seconds for Bus A and approximately 200 seconds for Bus B; for higher delay values no statistically significant degradations of mean voltage quality can be observed any more. Bus C on the other hand only shows some small but still statistically significant impact on voltage quality in the delay ranges below 100s.

Regarding information quality, the mean information age is in this scenario also identical to the one obtained by numeric integration in Section III by the analytic model, and therefore not shown again here. The mmPr metric on the other hand is interesting, as it depends on the evolution of the voltage values. The estimator for the mmPr from the simulations together with 95% confidence intervals is shown in Figure G.15. The mmPr mean estimate is increasing monotonically for increasing network delays, with again different ranges of delays for which this increase is statistically significant for the different buses. For Buses A and B, these ranges of delay values with significant impact on mmPr are actually comparable to the voltage quality analysis, i.e up to approximately 500s for Bus A, a little bit less for Bus B. Only for

## 5. Simulation analysis of controlled system with non-ideal information access

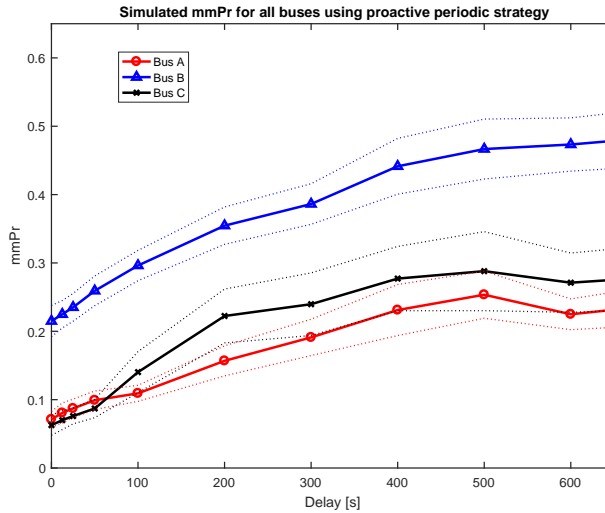
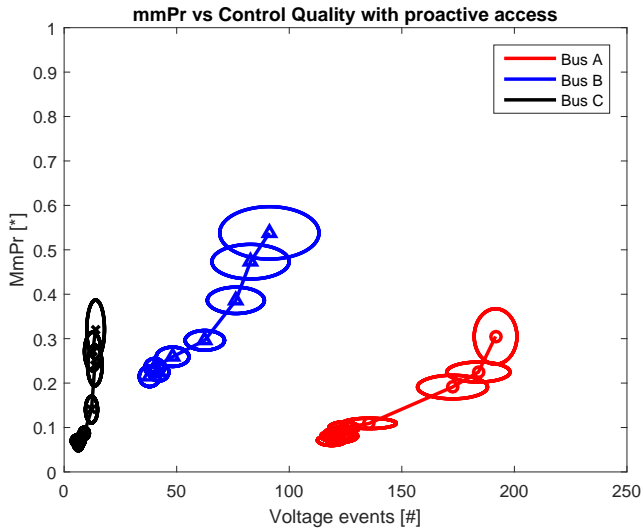

**Fig. G.16:** Simulated mmPr of the voltage controller with periodic asset information updates and increasing communication network delays.

the generally well behaving Bus C, mmPr shows a strong dependence on network delays for clearly longer ranges of network delays as opposed to voltage quality. Notice that in contrast to the reactive scheme, the periodic scheme also has a non-zero mmPr when the network delay is zero; the latter is a consequence of the periodic update generation process.

Note that mmPr is worst for Bus B, while voltage quality in general is worst for Bus C. This is not counter intuitive, as mmPr does not use any specifics of the control thresholds, or of metrics that define voltage quality. It instead puts delays and information age into relation to time variability of the voltage values that are accessed. Therefore the absolute value of mmPr cannot be used across buses to identify the buses with poor voltage quality, but instead the benefit lies in the capability to identify what communication delay ranges can be of interest to spend effort on for improvement, e.g. reducing network delays for asset information from one Bus at the cost of another via prioritization mechanisms in the communication network, when the latter bus is anyway already in the parameter range where mmPr (and hence voltage quality) will not degrade further.

Finally, we again plot the resulting relationship between system performance and mmPr in Figure G.17. The figure shows the clearly positive correlation between these two metrics; however, this positive correlation is only visible in the lower left part of the points for Bus C, as that bus does not show any significant degradation of voltage quality any more for higher commu-



**Fig. G.17:** Simulated mmPr vs system performance for the voltage controller with periodic information access and changing network delays.

nication network delays.

Finally, we also assess in the following the impact of the update interval for the periodic strategy. The simulations in this set of experiments use an exponentially distributed communication network delay with mean 100s.

Figure G.18 shows the number of voltage events as the update interval is changed. Large update intervals may be chosen when there is an interest to reduce communication network traffic; the latter is in particular relevant, since the periodic updates are always sent out, even when the controller is not active. Only Bus B shows some significant degradation for increasing update intervals; the other two buses are pretty unaffected when ignoring the statistical fluctuations. So in the given parameter setting, the update intervals in the shown ranges only shows some slight significant impact for Bus B.

The latter is also confirmed by the resulting mismatch probabilities, which are shown in Figure G.19. Bus B is the one that is in absolute values showing the highest mmPr. All three buses show only a gradual degradation of mmPr, while the mean estimators show increasing variability for larger delays.

The correlation plot in Figure G.20 again shows the clearest picture for Bus B, while the insensitivity of the voltage quality performance for Bus A and Bus C in the chosen parameter range leads to approximately vertical lines.

## 6. Conclusion and future work

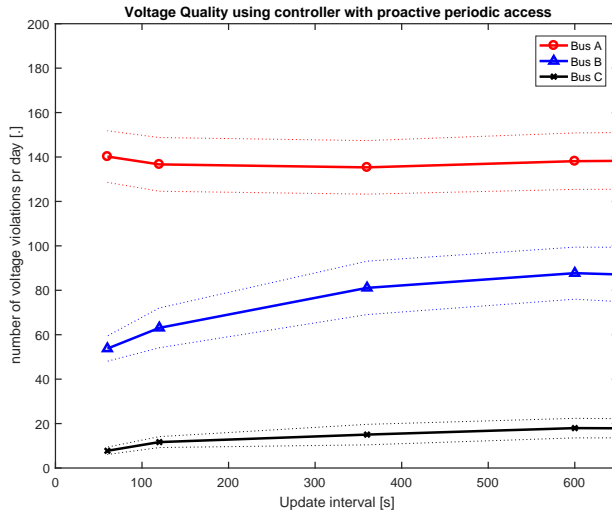

**Fig. G.18:** Simulated voltage quality performance when using a controller with periodic asset information updates and increasing mean time between updates; the seemingly decay of the blue curve on the right side is just an impact of stochastic variability, and must be seen in conjunction with the dotted 95%-confidence intervals.

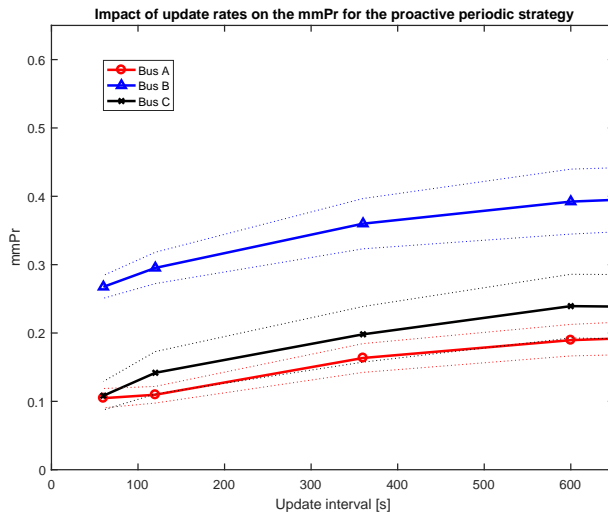

**Fig. G.19:** Simulated mmPr for increasing update intervals of the periodic scheme.

## 6 Conclusion and future work

This paper investigated an event-driven voltage controller for Low-Voltage distribution grids. The impact of this controller on the number of voltage

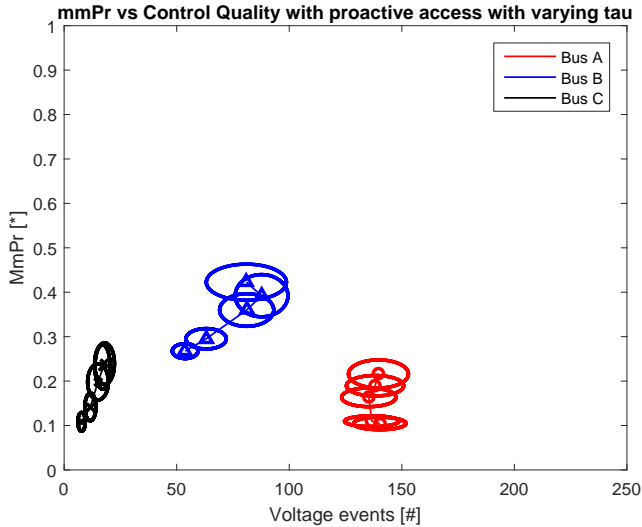

**Fig. G.20:** Simulated mmPr vs Control performance when changing the update interval of the periodic scheme.

events in different buses of a reference grid was evaluated via simulation experiments. For scenarios of non-ideal information access, two access schemes were defined and analyzed: a reactive access of the controller to asset measurements and a periodic scheme, in which assets update the controller regularly irrespective of whether the controller is active. Mathematical models for two information quality metrics, information age and mismatch probability, were derived and numerical results were obtained; in the case of mmPr, the behaviour of voltage measurements was thereby modelled by a Markov model that was fitted to a simulation trace.

The simulation results on mmPr and voltage quality under the corresponding controller show the same qualitative behaviour - therefore mmPr could be used to identify relevant delay ranges and update period interval ranges that are expected to have impact on voltage quality performance. So these metrics can be used to optimize communication network and information access configurations without having to consider the detailed controller realization. Information age on the other hand does not provide this capability as it changes linearly (in case of periodic schemes approximately linear) over the whole range of delay values.

Both information age and mismatch probability can be calculated analytically; for the latter, a Markov model was used in this paper to capture the behaviour of the voltage grid; it was fitted to the voltage trace, when the grid was not exposed to voltage control operations. In comparison to the simu-

## 7. Acknowledgement

lation results, the numerically calculated mmPr metrics, however, showed a sensitivity only to small delay values, and in this form cannot yet be used for decisions on parameter optimizations. More work and analysis regarding better modelling approaches for the grid behaviour, while still remaining computationally tractable for mmPr calculation, need to be invested in the future.

## 7 Acknowledgement

This paper summarizes selected results from the research project ‘Smart Control of Energy Distribution Grids over Heterogeneous Communication Networks – SmartC2Net’, [www.smartc2net.eu](http://www.smartc2net.eu), Grant Agreement number: 318023, which was supported by the European Commission within the 7th Framework Programme.



**Thomas Kristensen** was born in Silkeborg, Denmark on the August 18th 1988. He graduated from Aalborg University in 2013 with a masters degree in Networks and Distributed systems with his thesis on network adaptations for smart grid controllers. He continued his studies in this field as a PhD candidate at Aalborg University where he specialized in information quality estimation and the role of this in smart grid control systems.



**Rasmus Løvenstein Olsen** is an Associate Professor at Aalborg University working in the Wireless Communication Networks (WCN) group. Rasmus received his master degree from Aalborg University in 2003 and has received his PhD degree on the topic of Context Sensitive Service Discovery and Context Management with focus on access to dynamic information in 2008. Rasmus’ current research focus is on the role of communication networks in smart grid and the impact of networks on remote access to dynamic data of the collection as well as the distribution of information. Previously, Rasmus has previous been guest visitor at National Institute of Communication Technology in Yokosuka Research Park in Japan, cooperating with a team of researchers on next generation network technology.



**Jakob Gulddahl Rasmussen** is an Associate Professor at the Department of Mathematical Sciences at Aalborg University working with statistics, in particular spatial statistics. In 2003 Jakob received his master degree with a major in mathematics and a minor in English, and in 2006 he received his PhD degree in spatial statistics focusing on various aspects of temporal and spatio-temporal processes. Jakob has been teaching courses and supervising project in mathematics and statistics to students ranging from first year master students to PhD students in various areas of study, e.g. mathematics, economics, engineering. Jakob has over 20 published papers in international peer reviewed journals and conference proceedings, and he is co-applicant of several successful grants from the Danish Council for Independent Research, Natural Sciences, VKR Centres of Excellence, and the Australian Research Council. Jakob's current research revolves around theory and applications of statistics in various areas, in particular within the areas of (spatial) point processes and stochastic fields and applications of statistics in the area of communication networks.



**Hans-Peter Schwefel** is Professor for Communication Networks at Aalborg University, Denmark, and managing director of the startup company GridData ([www.griddata.eu](http://www.griddata.eu)). In parallel to his position at Aalborg University, he has previously been Scientific Director of the Research Center for Telecommunications (Forschungszentrum Telekommunikation Wien - FTW) in Vienna, Austria in 2008-2016. His research focuses on IP-based communication networks and their applications for critical infrastructures with main interest in performance and dependability aspects. Before he joined Aalborg University, he was a project manager at Siemens Information and Communication Mobile, supervising research projects and responsible for the development of technical concepts for next generation mobile networks. He obtained his doctoral degree in the area of IP traffic and performance modeling from the Technical University in Munich, Germany.

## References

- [1] C. H. Lo and N. Ansari, "Decentralized controls and communications for autonomous distribution networks in smart grid," *IEEE Transactions on Smart Grid*, vol. 4, no. 1, pp. 66–77, March 2013.
- [2] A. Bidram and A. Davoudi, "Hierarchical structure of microgrids control system," *IEEE Transactions on Smart Grid*, vol. 3, no. 4, pp. 1963–1976, Dec 2012.



## References

- [3] M. Findrik, R. Pedersen, E. Hasenleithner, C. Sloth, and H. P. Schwefel, "Test-bed assessment of communication technologies for a power-balancing controller," in *2016 IEEE International Energy Conference (ENERGYCON)*, April 2016, pp. 1–6.
- [4] A. Lucas and S. Chondrogiannis, "Smart grid energy storage controller for frequency regulation and peak shaving, using a vanadium redox flow battery," *International Journal of Electrical Power & Energy Systems*, vol. 80, pp. 26 – 36, 2016. [Online]. Available: <http://www.sciencedirect.com/science/article/pii/S0142061516000375>
- [5] S. J. Crocker and J. L. Mathieu, "Adaptive state estimation and control of thermostatic loads for real-time energy balancing," in *2016 American Control Conference (ACC)*, July 2016, pp. 3557–3563.
- [6] W. P. M. H. Heemels, A. R. Teel, N. van de Wouw, and D. Nešić, "Networked control systems with communication constraints: Tradeoffs between transmission intervals and delays," in *2009 European Control Conference (ECC)*, Aug 2009, pp. 4296–4301.
- [7] R. Pedersen, M. Findrik, C. Sloth, and H.-P. Schwefel, "Network condition based adaptive control and its application to power balancing in electrical grids," *Sustainable Energy, Grids and Networks*, 2017, submitted.
- [8] N. G. E. T. plc, *The grid code Issue 5*, 21st ed. National Grid Electricity Transmission plc, March 2017.
- [9] P. Kumar and A. K. Singh, *Grid Codes: Goals and Challenges*. Singapore: Springer Singapore, 2014, pp. 17–39. [Online]. Available: [http://dx.doi.org/10.1007/978-981-4585-27-9\\_2](http://dx.doi.org/10.1007/978-981-4585-27-9_2)
- [10] K. V. Katsaros, W. K. Chai, N. Wang, G. Pavlou, H. Bontius, and M. Paolone, "Information-centric networking for machine-to-machine data delivery: A case study in smart grid applications," *IEEE Network*, vol. 28, no. 3, pp. 58–64, June 2014.
- [11] K. Moslehi and R. Kumar, "A reliability perspective of the smart grid," *IEEE TRANSACTIONS ON SMART GRID*, vol. 1, no. 1, June 2010.
- [12] T. Sauter and M. Lobashov, "End-to-end communication architecture for smart grids," *IEEE TRANSACTIONS ON INDUSTRIAL ELECTRONICS*, vol. 58, no. 4, Nov. 2011.
- [13] M. Bøgsted, R. L. Olsen, and H.-P. Schwefel, "Probabilistic models for access strategies to dynamic information elements," *Performance Evaluation*, vol. 67, no. 1, pp. 43 – 60, 2010. [Online]. Available: <http://www.sciencedirect.com/science/article/pii/S0166531609001175>

## References

- [14] H.-P. Schwefel, M. B. Hansen, and R. L. Olsen, "Caching strategies for context management systems," *PIMRC07*, 2007.
- [15] J. Madsen, M. Findrik, T. Madsen, and H.-P. Schwefel, "Optimizing data access for wind farm control over hierarchical communication networks," *International Journal of Distributed Sensor Networks*, vol. 12, no. 5, 2016.
- [16] J. Y. Wen, Q. H. Wu, D. R. Turner, S. J. Cheng, and J. Fitch, "Optimal coordinated voltage control for power system voltage stability," *IEEE Transactions on Power Systems*, vol. 19, no. 2, pp. 1115–1122, May 2004.
- [17] R. Pedersen, C. Sloth, and R. Wisniewski, "Active power management in power distribution grids: Disturbance modeling and rejection," in *Control Conference (ECC), 2016 European*, 2016.
- [18] S. Consortium, "Control framework and models," 2015, <http://smarc2net.eu/public-deliverables/>.
- [19] R. Pedersen, C. Sloth, G. B. Andresen, and R. Wisniewski, "Disc: A simulation framework for distribution system voltage control," in *2015 European Control Conference (ECC)*, July 2015, pp. 1056–1063.
- [20] R. Pedersen, "Power management and voltage control using distributed resources," *Aalborg Universitetsforlag, VBN, Ph.D. thesis*, 2016.
- [21] L. Lipsky., *Queueing Theory: A Linear Algebraic Approach*. New York: Springer, 2009.
- [22] R. T. G. Dondossola, "Security of communications in voltage control for grids connecting distributed energy resources: impact analysis and anomalous behaviours," *CIGRE Science and Engineering*, 2015.



ISSN (online): 2446-1628  
ISBN (online): 978-87-7112-985-4

AALBORG UNIVERSITY PRESS