



Step-Up DC-DC converters

A comprehensive review of voltage-boosting techniques, topologies, and applications

Forouzesh, Mojtaba; Siwakoti, Yam P.; Gorji, Saman A.; Blaabjerg, Frede; Lehman, Brad

Published in:

IEEE Transactions on Power Electronics

DOI (link to publication from Publisher):

[10.1109/TPEL.2017.2652318](https://doi.org/10.1109/TPEL.2017.2652318)

Publication date:

2017

Document Version

Publisher's PDF, also known as Version of record

[Link to publication from Aalborg University](#)

Citation for published version (APA):

Forouzesh, M., Siwakoti, Y. P., Gorji, S. A., Blaabjerg, F., & Lehman, B. (2017). Step-Up DC-DC converters: A comprehensive review of voltage-boosting techniques, topologies, and applications. *IEEE Transactions on Power Electronics*, 32(12), 9143-9178. Article 7872494. <https://doi.org/10.1109/TPEL.2017.2652318>

General rights

Copyright and moral rights for the publications made accessible in the public portal are retained by the authors and/or other copyright owners and it is a condition of accessing publications that users recognise and abide by the legal requirements associated with these rights.

- Users may download and print one copy of any publication from the public portal for the purpose of private study or research.
- You may not further distribute the material or use it for any profit-making activity or commercial gain
- You may freely distribute the URL identifying the publication in the public portal -

Take down policy

If you believe that this document breaches copyright please contact us at vbn@aub.aau.dk providing details, and we will remove access to the work immediately and investigate your claim.

Step-Up DC–DC Converters: A Comprehensive Review of Voltage-Boosting Techniques, Topologies, and Applications

Mojtaba Forouzesh, *Student Member, IEEE*, Yam P. Siwakoti, *Member, IEEE*,
Saman A. Gorji, *Student Member, IEEE*, Frede Blaabjerg, *Fellow, IEEE*, and Brad Lehman, *Senior Member, IEEE*

Abstract—DC–DC converters with voltage boost capability are widely used in a large number of power conversion applications, from fraction-of-volt to tens of thousands of volts at power levels from milliwatts to megawatts. The literature has reported on various voltage-boosting techniques, in which fundamental energy storing elements (inductors and capacitors) and/or transformers in conjunction with switch(es) and diode(s) are utilized in the circuit. These techniques include switched capacitor (charge pump), voltage multiplier, switched inductor/voltage lift, magnetic coupling, and multistage-/level, and each has its own merits and demerits depending on application, in terms of cost, complexity, power density, reliability, and efficiency. To meet the growing demand for such applications, new power converter topologies that use the above voltage-boosting techniques, as well as some active and passive components, are continuously being proposed. The permutations and combinations of the various voltage-boosting techniques with additional components in a circuit allow for numerous new topologies and configurations, which are often confusing and difficult to follow. Therefore, to present a clear picture on the general law and framework of the development of next-generation step-up dc–dc converters, this paper aims to comprehensively review and classify various step-up dc–dc converters based on their characteristics and voltage-boosting techniques. In addition, the advantages and disadvantages of these voltage-boosting techniques and associated converters are discussed in detail. Finally, broad applications of dc–dc converters are presented and summarized with comparative study of different voltage-boosting techniques.

Index Terms—Coupled inductors, multilevel converter, multistage converter, pulse width modulated (PWM) boost converter, switched capacitor (SC), switched inductor, switched mode step-up dc–dc converter, transformer, voltage lift (VL), voltage multiplier.

Manuscript received May 24, 2016; revised November 15, 2016; accepted January 7, 2017. Date of publication March 6, 2017; date of current version August 2, 2017. (All papers from Northeastern University, Boston, are handled by Editor-at-Large, Prof. P. T. Krein, in order to avoid conflict of interest.) Recommended for publication by Associate Editor D. J. Perreault.

M. Forouzesh, Y. P. Siwakoti, and F. Blaabjerg are with the Department of Energy Technology, Aalborg University, Aalborg 9220, Denmark (e-mail: m.forouzesh.ir@ieee.org; yas@et.aau.dk; fbl@et.aau.dk).

S. A. Gorji is with the School of Software and Electrical Engineering, Swinburne University of Technology, Hawthorn, VIC 3122, Australia (e-mail: sasgharigorji@swin.edu.au).

B. Lehman is with the Department of Electrical and Computer Engineering, Northeastern University, Boston, MA 02115 USA (e-mail: lehman@ece.neu.edu).

Color versions of one or more of the figures in this paper are available online at <http://ieeexplore.ieee.org>.

Digital Object Identifier 10.1109/TPEL.2017.2652318

I. INTRODUCTION

SWITCHED-MODE step-up dc–dc converters originated with the development of pulse width modulated (PWM) boost converters. Step-up dc–dc topologies convert lower dc voltage levels to higher levels by temporarily storing the input energy and then releasing it into the output at a higher voltage level. Such storage can occur in either magnetic field storage components (single inductor/coupled inductor) or electric field storage components (capacitors) through the use of various active or passive switching elements (power switches and diodes). With the introduction of semiconductor switches in the 1950s, step-up dc–dc converters achieved steady performance advancements and their use accelerated through the 1960s when semiconductor switches became commercially available with allied manufacturing technologies [1]. The rise of the aerospace and telecommunication industries further extended the research boundaries of boost converters, especially in applications where efficiency, power density, and weight were of major concern. Efficiency has steadily improved since the late 1980s owing to the use of power field-effect transistors (FETs), which are able to switch more efficiently at higher frequencies than power bipolar junction transistors while incurring lower switching losses and requiring a less complicated drive circuit. In addition, the FET replaces output rectifying diodes through the use of synchronous rectification, whose “on resistance” is much lower than and further increases the efficiency of the step-up dc–dc converter, which requires a higher number of diodes for voltage boosting [1]–[3].

A PWM boost converter is a fundamental dc–dc voltage step-up circuit with several features that make it suitable for various applications in products ranging from low-power portable devices to high-power stationary applications. The widespread application of PWM boost dc–dc converters has been driven by its low number of elements, which is a major advantage in terms of simplifying modeling, design implementation, and manufacturing. The voltage step-up capability of a PWM boost dc–dc converter is enabled by an inductor at the input side that can operate either with a continuous current—in the so-called continuous conduction mode (CCM)—or including a zero current state in the discontinuous conduction mode (DCM). In general, CCM operation is more prevalent owing to the load dependent voltage gain, high current ripple, and low efficiency

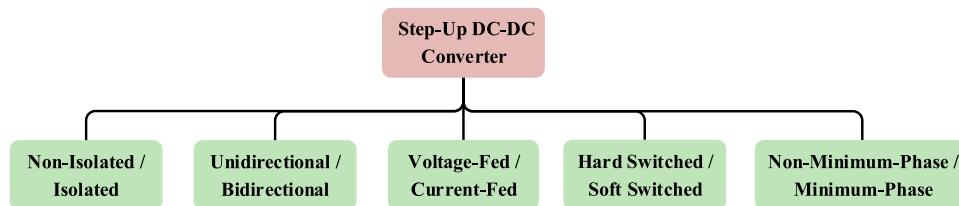

Fig. 1. Categorization of step-up dc–dc converters.

of DCM operation. However, the higher stability characteristics of the boost converter and smaller inductor implementation in the DCM mean that, occasionally, DCM operation of step-up dc–dc converters is preferable [4]–[5]. In addition to the abovementioned features, a PWM boost converter also has several shortcomings: hard switching and severe reverse recovery in the output diode, both of which cause lower efficiency; nonminimum-phase (NMP) characteristics owing to the presence of a right half plane (RHP) zero, which leads to difficult high-bandwidth control design; low voltage gain with moderate duty cycle switching; and low power density, which may lead to inefficient operation in high-voltage/power applications. Some of the shortcomings in conventional boost converters have led researchers to investigate and discover new topologies and operational methods, especially when high input-to-output boost ratio and better dynamics, stability, and reliability, along with higher power density and efficiency, are sought. Furthermore, improvements have been made in improving the power supply rejection ratio and input voltage and current ripples while lowering electromagnetic interference (EMI) and costs [6]–[11].

Within the literature discussed later in the paper, there is a consistent demand for reliable, efficient, small-sized, and lightweight step-up dc–dc converters for various power applications. Some of these demands can be simply achieved by using second-, third-, and fourth-order fundamental PWM dc–dc converters, e.g., boost, SEPIC, Ćuk, and Zeta converters. Furthermore, flyback, forward, push–pull, half-, and full-bridge converters are still popular and are employed for use at various voltage and power levels in which galvanic isolation is required. However, the literature also presents more complicated newer topologies that utilize different voltage-boosting techniques such as using multilevel, interleaved, or cascaded topologies, or using voltage multiplier cells (VMC), perhaps even combined with switched capacitors (SCs) and/or coupled inductors [12]–[309]. Each topology has its own advantages and disadvantages and should be selected based on the application and its requirements, e.g., isolated/nonisolated, unidirectional/bidirectional, voltage-fed/current-fed, hard/soft switched, or with/without minimum-phase characteristics.

The permutations and combinations of various voltage-boosting techniques form an immense number of topologies and configurations. This can be both confusing and difficult to survey and implement for particular applications. In this paper, to provide researchers with a global picture of the array of step-up dc–dc converters proposed in the literature, numerous boosting techniques and topologies are surveyed and categorized. Indeed, a great part of this paper is devoted to demonstrating recent con-

tributions and possibilities in terms of providing step-up voltage gain. The paper provides a “one-stop” information source with various categorizations of voltage-boosting techniques for step-up power conversion applications. These categorizations should assist researchers in understanding the advantages and disadvantages of various voltage-boosting techniques and topologies in terms of their applications. With this intention, a broad topological overview based on the characteristics of step-up dc–dc converters is first presented in Section II. To discuss different voltage-boosting techniques, namely—SC [charge pump (CP)], voltage multiplier, switched inductor/voltage lift (VL), magnetic coupling, and multistage/-level—a comprehensive review based on the respective major circuits is presented in Section III. Finally, an applicational overview of step-up dc–dc converters is presented in Section IV and concluded in Section V.

II. CATEGORIES OF STEP-UP DC–DC CONVERTERS

Fig. 1 illustrates a general categorization of step-up dc–dc converters. In following subsections, the details of each class of converter with respective major circuits are described in the following general form.

A. Nonisolated/Isolated

A basic method for stepping-up a dc voltage is to use a PWM boost converter, which comprises only three components (an inductor, a switch, and a diode). A PWM boost converter is a simple, low cost, and efficient nonisolated step-up converter suitable for many dc applications. Fig. 2(a) illustrates a general view of a nonisolated dc–dc converter along with a PWM boost converter. Analogous to a PWM boost converter, other nonisolated dc–dc structures are usually amenable to relatively low-power levels with reduced cost and size [10], [11]. Owing to their broad applicability and simplicity of implementation and design, much research has been dedicated to the subject of nonisolated dc–dc converters [32]–[224]. These circuits can be used with shared ground between the input and output or with a floated output, and Fig. 2(b) shows a general view of a nonisolated dc–dc converter with floated output along with a three-level boost converter. A shared connection between the input and output of nonisolated dc–dc converters can be used to improve the system performance of applications such as transformerless grid connected PV systems [12], and in addition to special applications in which a common ground between the input source and load is not necessary, the output of nonisolated dc–dc converters can also be floated in a manner similar to that in a three-level boost converter [13]. Furthermore, nonisolated

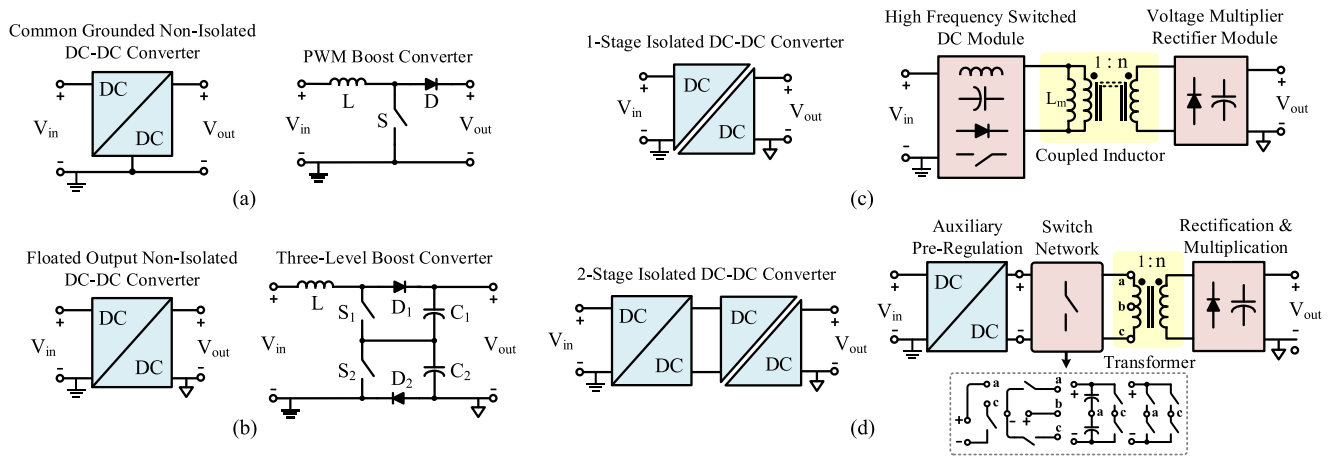

Fig. 2. Different nonisolated and isolated dc–dc converter structures. (a) Common grounded and (b) floated output nonisolated dc–dc converters. (c) Single-stage and (d) two-stage isolated dc–dc converters.

dc–dc converters can be built with or without magnetic coupling. If high-voltage step-up is not considered and efficiency is not a major concern, nonisolated structures without magnetic coupling and comprising only switching devices and passive components can be a useful solution that simplifies converter design by eliminating the need for coupled magnetic design. However, in high-power systems, it is often beneficial to utilize magnetic coupling if high voltage gain is required, and doing so can improve both efficiency and reliability. Both the transformer in its nonisolated form (built-in) and the coupled inductor can be employed in nonisolated dc–dc structures [32]–[224].

Electrical isolation is an important feature for grid-tied dc–dc converters and for some other applications that require reliable power transfer with low noise and reduced EMI. The applicable safety standard indicates the voltage level of electrical isolation between the input and output of a dc–dc converter, which can be achieved by means of either transformer or coupled inductor [225]–[297]. Some sensitive loads such as those used in medical, military, and avionics applications are vulnerable to faults and noise; as safety is also a major concern for these applications, electrical isolation is typically necessary [239]–[241], [247], [248], [263], [281], [282], [288], and [293]. Isolated dc–dc converters can be single- or two-stage structures and can be implemented using either a coupled inductor or transformer. Fig. 2(c) shows schematics of single-stage isolated dc–dc converters and an isolated dc–dc converter with a coupled inductor. In this category, the coupled inductor will store energy in one cycle and then power the load in the other cycles; such converters usually operate at high frequency in order to reduce the size of the magnetic components. The literature reports on several isolated dc–dc converters that employ coupled inductors for various applications [242], [258]–[261], [271], [272], [275], [282], and [283]. In a high-frequency transformer, the voltage of an input dc source is converted to an ac voltage, often a square/quasi-square wave voltage, and then passed through the transformer. The switching concept in isolated dc–dc converters varies by topology, with forward, push–pull, half-, and full-bridge converters being examples of well-known transformer-based isolated dc–

dc structures [225]. Furthermore, there is a family of three-level transformer isolated dc–dc structures [233] that benefits from smaller current ripple and reduced voltage stresses compared with corresponding conventional converters. Flyback converters are a type of isolated buck–boost dc–dc converters that use a coupled inductor instead of an isolation transformer and store energy in the ON state of the switch while transferring it to the load in the OFF state of the switch. As shown in Fig. 2(d), an auxiliary converter can be employed in the first stage of a two-stage isolated dc–dc converter to preregulate the voltage level demanded. This auxiliary circuit, which can be a single dc–dc converter with separate modulation and control [225] or can comprise an impedance (Z -) source network, benefits from integrated modulation and control [226], [229]–[231]. Impedance source networks are an emerging technology in various power conversion applications, in which no additional active switches are required to provide step-up capability [20].

B. Unidirectional/Bidirectional

Most of the fundamental dc–dc converter types are used to transfer unidirectional power flow, in which the input source should only supply the load (in generation) or absorb the energy (in regeneration) [43]–[212], [229]–[277]. Unidirectional converters would be usable for this purpose in on board loads such as sensors, utilities, and safety equipment. A typical layout of such a converter, which is usually implemented via unidirectional semiconductors such as power MOSFETs and diodes, is shown in Fig. 3(a), in which conventional buck and boost converters are also depicted as basic examples of unidirectional dc–dc converters. In converters such as those shown, the power flow is unidirectional because single-quadrant switches are used, i.e., there is no path for the current to be conducted in the reverse direction in the diodes. By contrast, Fig. 3(b) shows the bidirectional structure of a nonisolated dc–dc converter, which can be realized by replacing the one-way direction semiconductors used in unidirectional topologies with current-bidirectional two-quadrant switches [278]. When unidirectional power flow

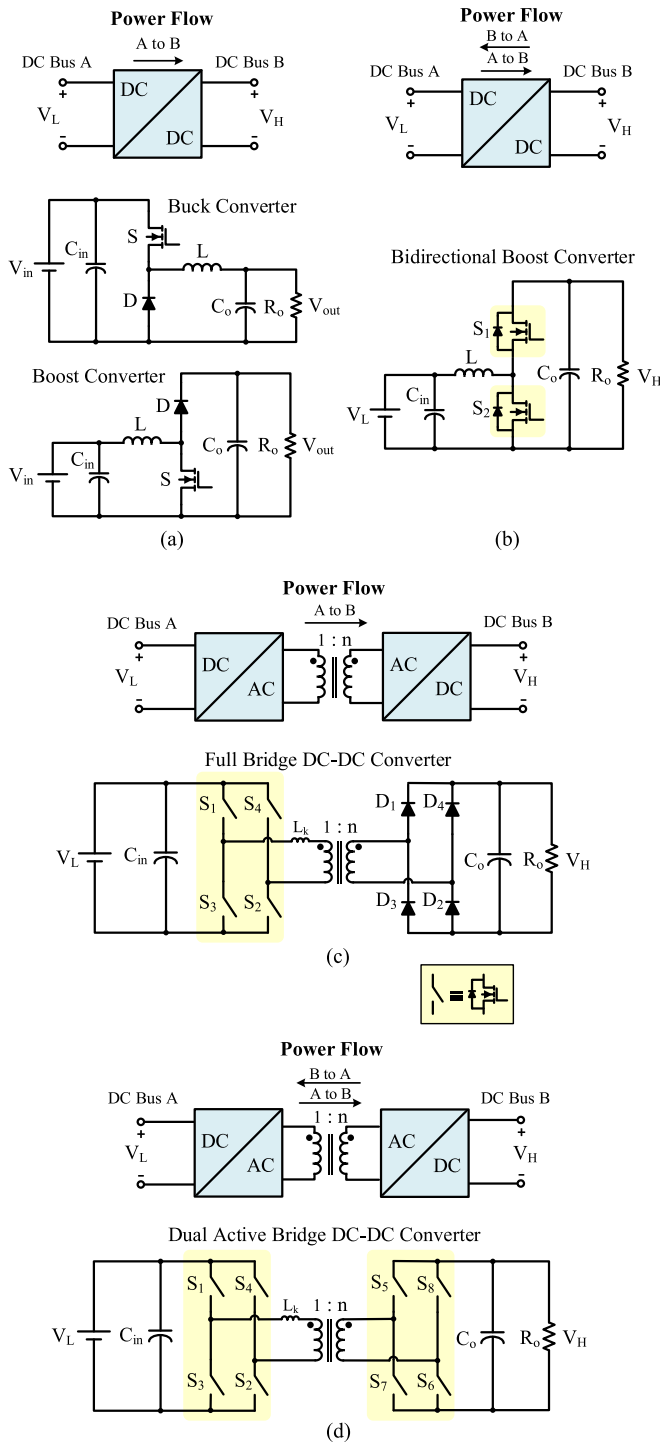

Fig. 3. Unidirectional and bidirectional dc-dc converters. (a) Nonisolated unidirectional and (b) nonisolated bidirectional dc-dc converters, (c) isolated unidirectional, and (d) isolated bidirectional dc-dc converters.

is desired, unidirectional converters are preferred owing to their lower number of controllable switches and correspondingly simpler control implementation.

An interesting design aspect of unidirectional boost converters is that, unlike high-power step-down applications, diodes can sometimes have minimized effects on the circuit's power efficiency. When the output voltage is much higher than the

rectifying diode voltage drop, in many applications, designers may decide to retain a diode instead of replacing it with a synchronous rectifier, even as power increases. On the other hand, buck-derived applications such as in voltage regulator modules have been trending toward lower output voltages that would be dominated by the diode power loss and therefore incorporate synchronous rectification and have topological bidirectional current flow capabilities in their switches. Boost-derived applications differ from buck-derived applications in that, while they may not have large output current, their voltage may be very high, e.g., > 600 V, in which case the diode voltage drop might not be as dominant in the power loss calculation.

As discussed in the previous subsection and as will be addressed in the following sections, isolation transformers may be employed either to augment the boost ability of a dc-dc converter or to provide other requirements (e.g., electrical isolation between the input and the output or meeting special standards for particular systems). Fig. 3(c) shows a schematic of an isolated unidirectional converter along with an example of a unidirectional dc-dc converter. The full-bridge dc-dc converter is a popular topology of this family, particularly when dealing with high-power levels such as in industrial applications. This type of converter comprises a dc-ac stage—a high-frequency isolation transformer—followed by a rectification stage. As an example of its various applications, the output voltage of a full-bridge dc-dc converter may supply an ac-dc inverter through a dc-link capacitor for use in a power supply system, ac motor, etc. [234], [245]–[247], [252]–[255], [264]–[267], [293].

The growing demand for applications with the storage system and bidirectional energy transfer capability will result in the increased use of bidirectional dc-dc converters. These converters are used in renewable energy systems, railway transportation (e.g., train and tramway), automotive transportation (e.g., hybrid electric vehicles (HEV) and vehicle to grid), aerospace applications, elevators and escalators, uninterruptable power supplies, batteries, supercapacitors, smart grid applications, and many other applications [213]–[223], [278]–[297]. Although, in principle, energy storage and bidirectional transfer can be achieved by implementing two unidirectional dc-dc converters—one to transfer power from the input to the output, and another to transfer power in the opposite direction—in practice, as mentioned previously, replacing unidirectional semiconductor elements with bidirectional switches will result in a bidirectional topology. Fig. 3(d) shows a schematic of an isolated bidirectional converter along with a popular example of a bidirectional dc-dc converter, dual active bridge (DAB), which is one of the most promising types of isolated bidirectional dc-dc converter derived from unidirectional full-bridge dc-dc converter topology. DAB converters are useful in high-voltage/power-level applications [280], [287]–[289]. In the DAB topology, energy transfer is controlled by adjusting the phase shift between two ac voltage waveforms across the windings of the isolation transformer, and control strategy is one of the more important subjects of research with regard to such converters [280].

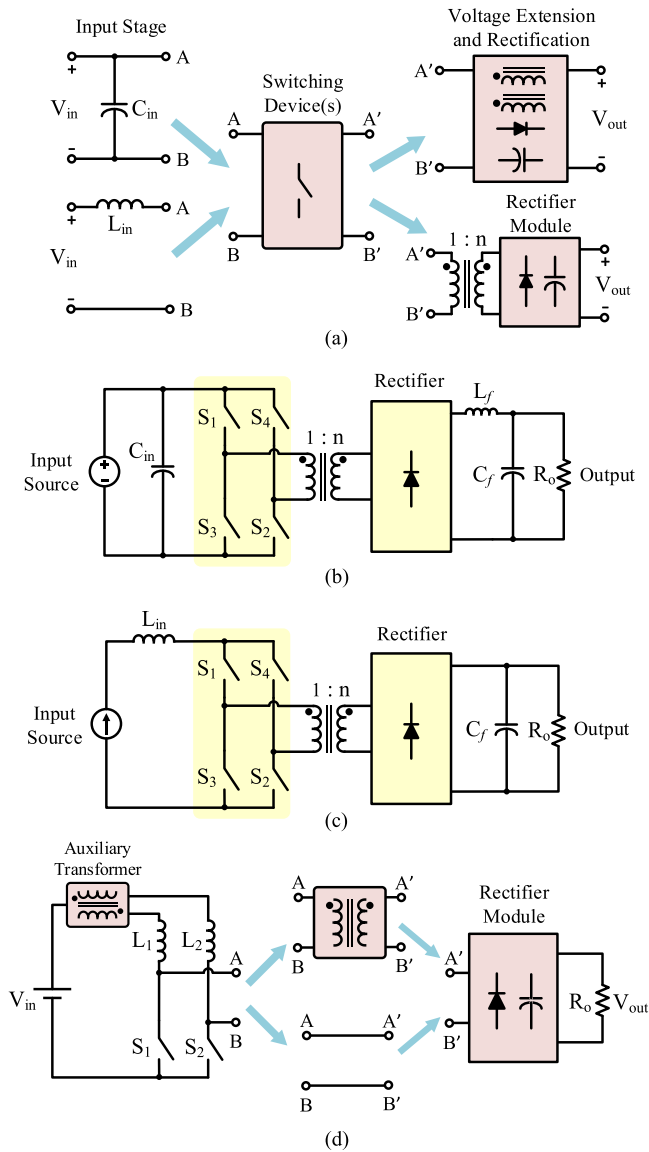

Fig. 4. Voltage- and current-fed dc–dc converter structures. (a) Common structure in isolated and nonisolated forms. (b) Voltage-fed full-bridge dc–dc converter. (c) Current-fed full-bridge dc–dc converter.

C. Voltage-Fed/Current-Fed

Depending on their input circuitry, step-up dc–dc converters can be classified as either voltage- or current-fed converters. Fig. 4(a) shows schematics of both types of dc–dc converters in their isolated and nonisolated forms. The voltage-fed dc–dc converter has a capacitive input filter (C_{in}) and normally can convert input voltage to a lower output voltage (neglecting multiple stages and assuming a turns ratio of unity for magnetic coupling) [54]–[212], [215]–[219], [233]–[263], [284]–[292]. Fig. 4(b) shows the well-known voltage-fed full-bridge converter suitable for high-power applications. It consists of an input capacitor and a low-pass filter at its output. As demonstrated in [234], its magnetic components can be integrated into a single core in order to reduce the size and cost of the converter. All switched-capacitor structures in step-up dc–dc converters, such as multilevel or flying capacitor converters, can be classified as

nonisolated voltage-fed dc–dc converters; such converters usually have fast dynamic response and are suitable for low-power applications [126].

Unlike voltage-fed converters, current-fed dc–dc converters have an input inductor at the input circuit and can normally convert the input voltage to a higher output voltage [138]–[212], [220]–[223], [264]–[277], [293]–[297]. Fig. 4(c) shows an example of the well-known current-fed full-bridge converter, which consists of an input inductor and a capacitive output filter. Because the switching devices at each leg of a voltage-source full-bridge converter are not allowed to turn ON at the same time (a condition known as shoot-through), the switching patterns must include a dead-time between the high- and low-side switches of each leg. On the other hand, as the switching devices of all legs of current source full-bridge dc–dc converter should not turn OFF simultaneously (known as open-circuit), the high- and low-side switches must always include an overlap. Unlike either of these structures, impedance source based dc–dc converters are immune to both shoot through and open circuit [20].

Two-inductor two-switch boost converters are another prominent type of current-fed dc–dc converters [135], [138], [270], [271]. A schematic of this type of converter is shown in Fig. 4(d). These converters can be used in isolated or nonisolated forms and with different rectifier modules. Furthermore, an auxiliary transformer can be integrated at the input to improve performance. Owing to the current balance effect of the auxiliary transformer, no energy is stored in the inductors when there is no overlapping of the conduction times of the two switches [138]. In addition, as demonstrated in [271], all magnetic components can be integrated into a single core to increase power density by reducing size and weight.

Current-fed dc–dc converters are very popular for low-voltage renewable energy applications such as photovoltaics (PVs) and fuel cells (FCs) because their input inductors can provide a continuous input current, typically with low ripple. This feature reduces the negative impacts of high ripple current on low-voltage high-current sources. By contrast, the lack of an input inductor in voltage-fed converters results in considerable ripple current at the input; however, as these converters have no RHP zero, they have faster dynamic response than current-fed converters with input inductors and RHP zero. However, this is not a general rule; Song and Lehman [272] introduced an interesting current-fed dual-bridge dc–dc converter with no RHP zero in its voltage transfer function, in which the voltage gain is similar to that of the voltage-fed topology in [235]. The issues relating to the RHP zero concept and its solutions will be discussed further in the following subsections. Current-fed converters usually can achieve a large range of soft switching and provide high efficiency over a large range of power rating in applications with wide input voltage variation [21], [232], [267]–[269], [278], [279], [294], [297].

D. Hard Switched/Soft Switched

A main drawback of hard-switched converters is their higher switching power loss. In addition, hard-switching converters

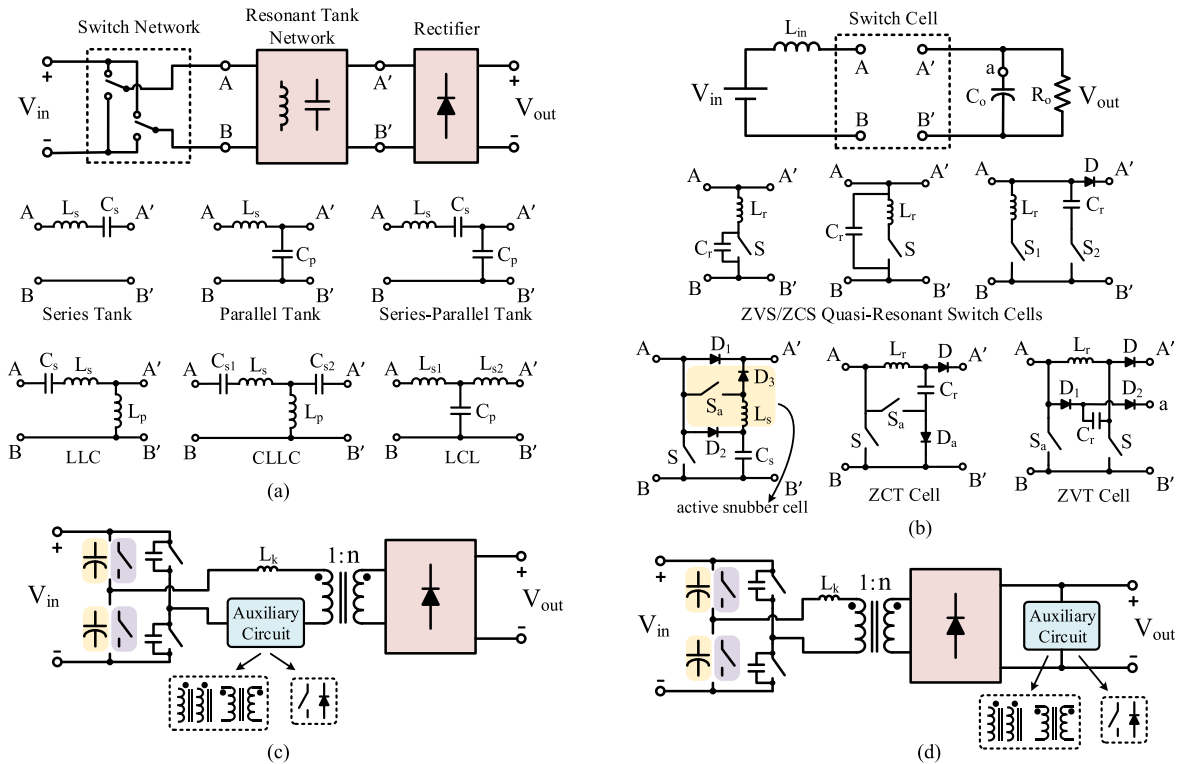

Fig. 5. Different soft switching dc-dc converters. (a) General resonant tank networks. (b) Various soft switching cells and soft switching isolated dc-dc converters with auxiliary circuits at (c) primary side and (d) secondary side.

may suffer from high EMI as a result of high dv/dt and di/dt at switch turn ON and turn OFF [7]. Because switching losses increase as the switching frequency increases, there often is a limit to the maximum switching frequency of such converters. Nevertheless, increasing power density in dc-dc converters means that higher frequency operation must be employed in order to reduce the size of passive magnetic/electric field storage components (i.e., L and C) and reach the ultimate miniaturization goals.

On the other hand, soft-switching converters can reduce the above disadvantages while utilizing stray inductance and capacitance as part of a resonance circuit to achieve zero-voltage switching (ZVS) or zero-current switching (ZCS). As voltage and current during transitions are zero, dc-dc converters can operate at high frequency, which often enables reductions in size and weight [127]–[137], [203]–[212], [218]–[219], [246]–[269], [288]–[292], [295]–[297].

Soft-switching converters can be classified as load resonant with resonant networks, active snubber switch cells, and isolated structures with auxiliary assisted circuits. Load-resonant converters are suitable for high-power applications because they allow reductions in the size/weight of the converter owing to their high-frequency operation without conversion efficiency degradation. Fig. 5(a) shows series, parallel, series-parallel (LCC), LLC, CLLC, and LCL resonant networks that can be used in dc-dc converters [139], [218], [227], [247]–[249], [290], [297]. Proper operation of these converters is quite dependent on the operating point and resonant frequency, making them not suitable for wide range of operating conditions. Another group

of soft-switching converters includes soft switch cell including quasi-resonant, active snubber and ZVS/ZCS, and ZVT/ZCT switch cells that can be implemented in various dc-dc converters to eliminate switching turn ON and turn OFF losses [32]–[37]. Fig. 5(b) illustrates some of these switch cell types implemented in dc-dc converters. Fig. 5(c) and (d) shows possible bridge structures with auxiliary circuits for soft switching at the primary and secondary sides of the isolated transformer, respectively. Auxiliary circuits can consist of an auxiliary transformer/coupled inductor or an active network (AN). Detailed analysis of primary-assisted soft-switching converters can be found in [250]–[253], and further detailed analysis of secondary-side-assisted soft-switching converters can be found in [253]–[256]. In addition to these soft-switching circuits, some non-isolated and isolated dc-dc converters also benefit from implementing a small resonant capacitor in series with one side of the magnetic coupling (i.e., coupled inductor/transformer) in order to achieve quasi-resonant operation. These circuits often have stable soft-switching features throughout their operating points and load variations [130], [203], [204], [207], [210], [266].

E. NMP/Minimum Phase

Systems with RHP zeros are called NMP systems. RHP zeros of a transfer function $n(s)/d(s)$ are all roots of $n(s) = 0$ with real parts greater than zero. Controllers for these NMP systems are more difficult to design because, as the gain increases in a conventional controller, the closed-loop poles will be attracted the RHP. Therefore, obtaining high gain using only output

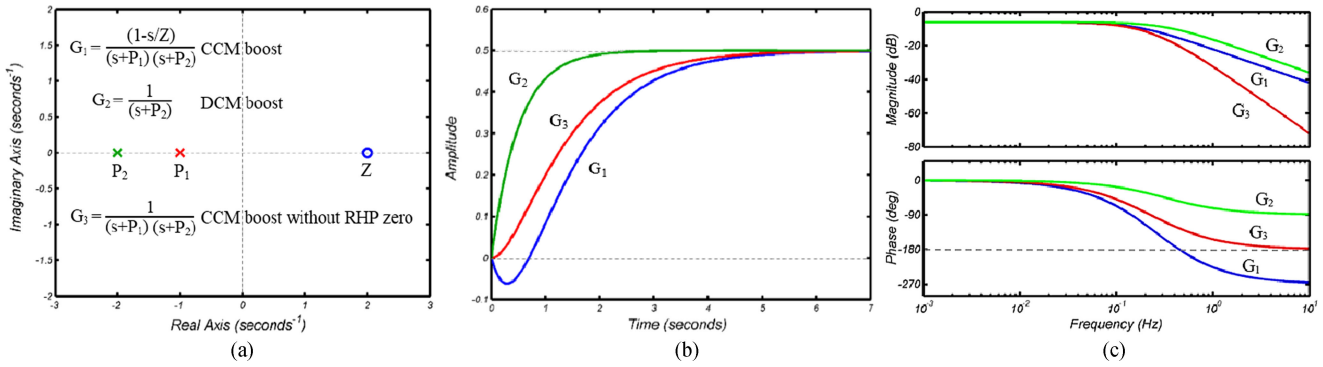

Fig. 6. Typical control to output transfer functions for boost dc–dc converters. (a) Illustration of pole/zero placement. (b) Dynamic response to a step change. (c) Bode plot for $G_1:1-s/Z/(s+P_1)(s+P_2)$, $G_2:1/(s+P_2)$, and $G_3:1/(s+P_1)(s+P_2)$.

voltage controllers in the boost converters may tend to result in destabilization; because of this, it is often difficult to create high-bandwidth controllers and the transient response may not be as fast as desired. The limitation in the maximum gain of the controller becomes more pronounced as the zero moves closer to the imaginary axis. Furthermore, as the poles tend to be destabilized, the phase margin often becomes limited, which makes the system more sensitive to computational or controller delays [22].

An interesting aspect of NMP systems is that their closed-loop transfer functions can maintain the same RHP zeros as their open-loop transfer functions. This symmetry leads to the so-called inverse response to the step input change in which, although the input reference increases, the output may initially decrease before rising to the reference [23]. Conventional dc–dc converters and most of the converters discussed previously in this paper have at least one RHP zero. Boost and buck–boost converters are two fundamental circuits that have an RHP zero in the control to output transfer function operating in the CCM. In both of these topologies, the real part of the RHP zero is roughly proportional to the load resistance and inversely proportional to the voltage gain. This means that in heavy-load (low load resistance) and high-voltage-gain applications, the RHP zero moves toward the imaginary axis, making feedback controllers more difficult to design. Although operating in the DCM can push the RHP zero to high frequencies, the ripple and peak currents in the devices in the DCM is higher than the CCM, and the efficiency is degraded in DCM operation as well [5]. Consequently, obtaining an acceptable stability margin in such converters is a concern for controller designers, and it is more difficult to achieve an adequate phase margin in conventional single-loop feedback systems with a wide bandwidth. This is especially true for high-voltage-gain high-power step-up converters.

To better understand the effects of system poles and zeros on the dynamic response and stability margin of boost converters, Fig. 6 illustrates a typical control to output transfer functions for boost and buck–boost converters operating in CCM (G_1) and DCM (G_2). The figure also demonstrates the behavior of boost converters without RHP zero (G_3). It should be noted that the illustration in Fig. 6 is an approximate demonstration based on different boost-type converters. A boost dc–dc converter oper-

ating in the CCM can be represented using two poles in the left half plane (LHP) and one RHP zero; in DCM operation, as the RHP zero placement is far away from the imaginary axis, the converter essentially functions as a first-order system with one LHP pole [5]. There are some boost-derived converters without RHP zero that can be represented with only two LHP poles. It is seen that G_1 performs NMP characteristics such as initial dip before the step rise and unstable phase margin. By contrast, G_2 and G_3 have no such dynamic or frequency response characteristics. Generally, G_2 has a fast dynamic response and a large stability margin; however, as mentioned earlier, DCM operation is problematic on fundamental boost-based converters. Although it would be possible to design special controllers for NMP and minimum-phase systems, the former is intrinsically more difficult owing to the effects of the RHP zero.

Various techniques can be employed to alleviate the effect of the RHP zero in boost converters. Although reducing the inductor value does not eliminate the RHP zero, it pushes it further from the origin and thus reduces the NMP effect. Furthermore, reducing the switching frequency increases the ripple and peak current in such devices. Often, light load and low voltage gains can help mitigate RHP zero effects. Alternatively, operating in the DCM allows for very stable dynamics without RHP zero problems but does not address CCM operation [189]–[191]. Furthermore, various control techniques have been introduced to overcome the problems caused by the RHP zero [192]–[195]. The compatibility of control techniques must be evaluated in terms of the adopted topology as each control technique has its own merits and drawbacks.

New boost converters with additional active switches are introduced in [196]. The resulting tristate boost converters eliminate the RHP zero in the control to output transfer function and can be used in applications in which fast-response boost action is needed. Fig. 7(b) and (c) shows two different tristate boost converter structures. By implementing an appropriate control technique on the tristate boost converter, the RHP zero can be totally eliminated at the desired operating point [196]. Another type of converter with RHP zero elimination, called the KY converter, is shown in Fig. 7(d). This converter has a nonpulsating output current and dynamic behavior that is fast as a buck converter with synchronous rectification [124]. However, the

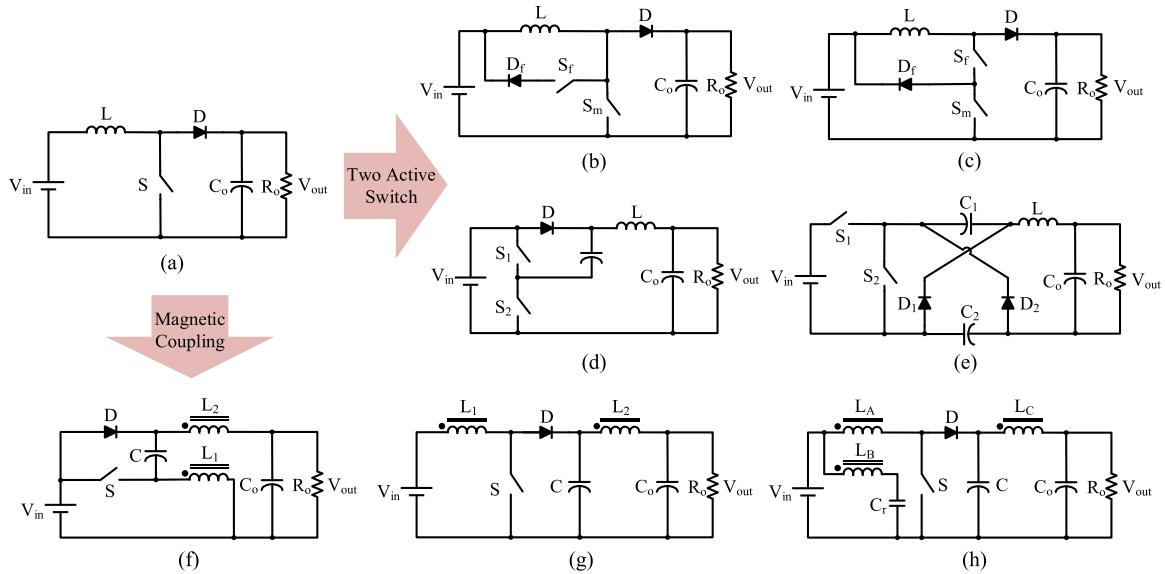

Fig. 7. Various derivations of minimum-phase boost converters. (a) PWM boost converter. (b)–(e) Different minimum-phase boost converters with two active switches. (f)–(h) Different minimum-phase boost converters using magnetic coupling.

voltage gain of KY converters is limited to $(1 + D)$, where D is the duty cycle of the main switch (S_1). For higher voltage gain, high-order-derived KY converters can be exploited but at the expense of additional switches for each stage. A new type of step-up boost converter employing an SC with no RHP zero is shown in Fig. 7(e) [125]. The voltage gain in this converter can be increased without the need for extra switches simply by increasing the SC stages [126].

Another way to eliminate RHP zero is to use magnetic coupling in the circuit of the boost converter. In [197], a two inductor boost converter with coupled inductors is presented [see Fig. 7(f)]. Assuming proper coupled-inductor design, this converter can eliminate the RHP zero. In a critically damped converter with zero coupling, the pair of zeros in the control to output transfer function are in the LHP; by increasing the coupling, one zero remains in the LHP and the other one moves to the RHP. A drawback of this converter type is that its switch is floating, which requires a special gate drive circuit. By using boost converters with output filters, it is possible to achieve magnetic coupling between the input inductor and output filter inductor [198], [199]. Fig. 7(g) shows the configuration of a boost converter with magnetic coupling of the output filter. The transfer function of this converter has two zeros, which by an appropriate selection of the duty ratio and the number of turns on the coupled inductor can be placed in the LHP [200]. Another improved boost converter type with no RHP zero and ripple-free input and output current is shown in Fig. 7(h). In this design, an input (L_A), ripple cancelation (L_B), and output (L_C) inductor are integrated into a single inductor in order to reduce size and weight. As it has additional windings, the efficiency of this converter is slightly degraded relative to that of a PWM boost dc–dc converter [201]. Additional methods for alleviating the NMP characteristics of step-up converters include an interesting two-phase interleaved inverse-coupled-inductor boost converter without RHP zeros, as proposed in [202]. In this method, both

the primary and secondary coupled inductors of one phase are connected inversely to the circuit; the inverse-coupled-inductor connection of both phases enables all inductors to be implemented on a single core.

As a conclusion to this section, a summary of main characteristics of the reviewed dc–dc structures can be found in Table I.

III. DIFFERENT VOLTAGE-BOOSTING TECHNIQUES

Step-up converters are used to implement various voltage boost techniques in dc–dc converters. Fig. 8 shows a broad categorization of the voltage-boosting techniques that can be found in the literature. Five major subsections are included, namely SC (CP), voltage multiplier, switched inductor and VL, magnetic coupling, and converters with multistage/-level structures. In the following section, the general structures of these techniques are first illustrated and then major circuits are shown to illustrate their underlying concepts in detail.

A. Switched Capacitor (Charge Pump)

The SC is a well-known voltage-boosting technique based on a CP circuit that is used in many converters. Voltage-level enhancement in a CP circuit comes solely from capacitive energy transfer and does not involve magnetic energy transfer. Among the many approaches to CP circuit implementation, SC topologies are very popular because of their structural modularity and capability for monolithic integration [54]–[57].

Fig. 9(a) shows a schematic CP circuit, in which two switches are turned ON and OFF in succession. When switch I is turned ON, capacitor C_1 charges to the input voltage level, and when switch II is turned ON, the stored energy in C_1 transfers to capacitor C_2 and the switches are phased alternately (odd-numbered switches (I) in phase 1, even numbered switches (II) in phase 2). This concept is called pumping the energy from one capacitor

TABLE I
SUMMARY OF DIFFERENT DC–DC CONVERTER STRUCTURES

DC–DC Converter Type	Features
Non-Isolated [32]-[224]	<ul style="list-style-type: none"> • Often simple structures with low weight and manufacturing cost. • Suitable for low to medium power levels. • Electrical connection between the input and output.
Isolated [225]-[297]	<ul style="list-style-type: none"> • Reduced noise and EMI problems. • Suitable for high power levels. • Meet most utility grid standards. • Easy implementation of multiple output topologies with positive and/or negative voltages. • Need precise coupled magnetic design for high voltage gain.
Unidirectional [43]-[212], [229]-[277]	<ul style="list-style-type: none"> • One direction power flow. • Simple modulation and control. • Less complex and cost compared to bidirectional.
Bidirectional [213]-[223], [278]-[297]	<ul style="list-style-type: none"> • Straight and reverse power flow. • Suitable for regenerative applications. • Demand complex FET driver and control units.
Voltage-fed [54]-[212], [215]-[219], [233]-[263], [284]-[292]	<ul style="list-style-type: none"> • Large input current ripple (often discontinuous) • Inherent buck characteristics. • Fast dynamic response.
Current-fed [138]-[212], [220]-[223], [264]-[277], [293]-[297]	<ul style="list-style-type: none"> • Continuous input current with small ripple. • Inherent boost characteristics. • Slow dynamic due to the input inductor and RHP zero.
Hard switched [54]-[126], [138]-[188], [215]-[217], [220]-[223], [233]-[245], [270]-[276], [285]-[287]	<ul style="list-style-type: none"> • Large switching loss. • High EMI due to high dv/dt and di/dt at switching transitions. • Limited switching frequency. • Low power density. • Often low efficiency
Soft Switched [127]-[137], [203]-[212], [218]-[219], [246]-[269], [288]-[292], [295]-[297]	<ul style="list-style-type: none"> • Near zero switching loss (ZVS and ZCS). • Partly complex analysis. • High switching frequency. • Improved power density. • High efficiency.
Non-minimum-phase [32]-[123], [127]-[188], [203]-[224], [225]-[297]	<ul style="list-style-type: none"> • Slow dynamic response. • Small stability margins. • Often challenging control designing.
Minimum-phase [124]-[126], [189]-[202]	<ul style="list-style-type: none"> • Fast dynamic response. • Large stability margin. • Easy control designing.

to another; and after several cycles, the output voltage reaches the input voltage level [54].

A two-phase SC voltage doubler (TPVD) is shown in Fig. 9(b). In the first phase, which is also shown in Fig. 9(b), capacitor C_1 is charged to the input voltage. In the second phase, capacitor C_1 is placed in series with the input source, which ideally doubles the output voltage level [68]. For higher voltage gains, the TPVD can be connected in series. Doubler SCs, as shown in Fig. 9(c), are based on the TPVD design, with the output voltage of each stage double its input voltage. A series–parallel connection SC technique is shown in Fig. 9(d). Series–parallel SC use capacitors efficiently, as the capacitors in this topology support the same voltage [69]. Fig. 9 shows a ladder SC, which consists of two sets (or ladders) of capacitors.

By changing the input voltage node in the lower ladder of capacitors, different voltage gains can be obtained from this type of SC. This topology uses switches efficiently, as the switching devices support the same voltage [69]. Fig. 9(f) shows the Dickson SC, which can be used as voltage multiplier. In the Dickson CP, which used diodes instead of active switches, two strings of pulses with a proper phase shift are required to drive switching [68]. The Makowski SC [70], illustrated in Fig. 9(g), can provide high-voltage boosting with low-device requirement. This SC circuit type is also known as a Fibonacci design owing to the fact that its voltage gain characteristic increases according to the Fibonacci number sequence $\{1, 1, 2, 3, 5, 8, 13, \dots\}$. The voltage gain in a Dickson CP, on the other hand, increases linearly with the number of power stages, i.e., the output voltage is theoretically equal to $N \cdot V_{in}$, where N is the number of CP stages. By contrast, the voltage gain in a Makowski CP grows exponentially with the number of switching devices [57]. The conversion Ratio in a Makowski CP is equal to $n = F_{k+1}$; thus, for a CP circuit with k capacitors, the conversion ratio is equal to the $(k+1)$ th Fibonacci number. The Fibonacci numbers can be calculated using $F_j = (\varphi^j - (1 - \varphi)^j) / \sqrt{5}$, where φ is the golden ratio ($\varphi = (1 + \sqrt{5})/2$) [57]. Although, exponential SC topologies (Fibonacci and Doubler) have high step-up capabilities, they perform relatively poorly with respect to switch and capacitor voltage stresses as they involve a wide range of different voltages and most of the switches are not ground referenced, which makes implementation difficult [69].

A critical issue related to SC circuits is their high-current transients, which have a degrading effect on both power density and efficiency. One way to prevent the detrimental effects of current transients in SC circuits is to insert an inductor at the output in order to form a buck converter with the existing switch(es). This technique has the two advantages of providing efficient regulation and eliminating current transients, which together are known as the soft-charging of SC converters. In [133], a methodology for implementing this technique on several reviewed SC circuits was presented, which led to the development of a family of high-performance resonant SC converters.

Fig. 10(a) shows an SC dc–dc converter with common characteristics of SC converters such as low weight and small size. This converter has a prominent feature of a continuous input current waveform [71]. A converter similar to that shown in Fig. 10(a) was presented in [48] using active switches instead of diodes. Another SC dc–dc converter with resonant operation is shown in Fig. 10(b). In this topology, a small resonant inductor is used in the first stage to achieve ZCS. Based on this, the current spike that usually occurs in classical SC converters can be eliminated [132]. A multilevel modular capacitor-clamped dc–dc converter (MMCCC) is shown in Fig. 10(c). This converter uses a modular structure to achieve any required voltage gain, high-power transfer with a simple gate drive, and fault by-passing and bidirectional power management capabilities [216], [217]. A ZCS operation of the MMCCC can be found in [131]. This converter employs the distributed stray inductances of each SC module to provide zero current turn ON and OFF to the devices; as a consequence, voltage and current spikes are reduced, power losses are minimized, and efficiency is increased.

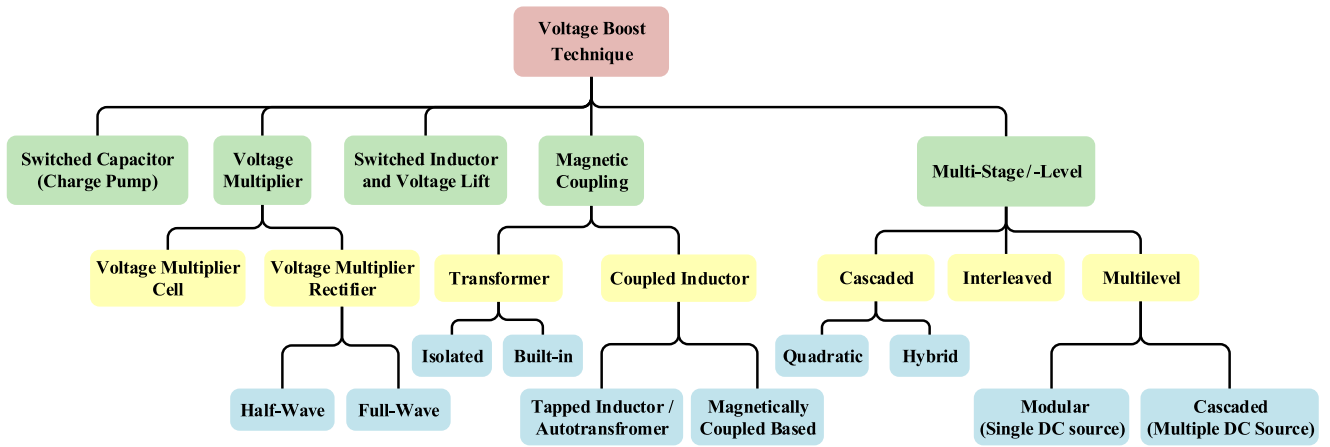

Fig. 8. Broad categorizations of voltage boost techniques used for dc–dc converters.

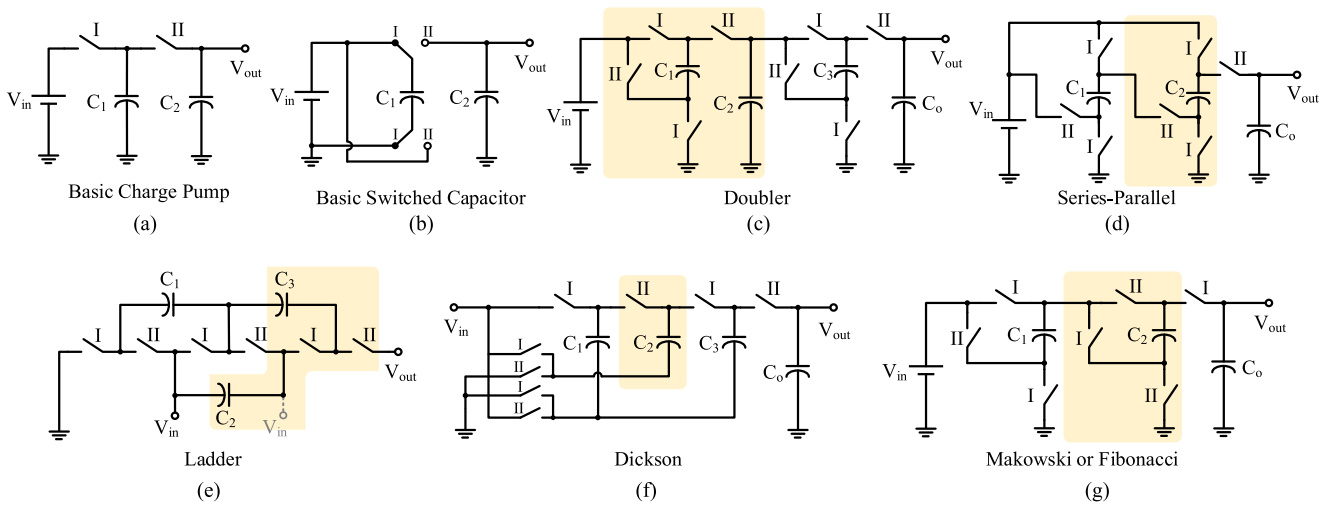

Fig. 9. Basic charge pump and switched capacitor circuits. (a) Basic charge pump. (b) Basic switched capacitor. (c) Doubler. (d) Series–parallel. (e) Ladder. (f) Dickson. (g) Makowski or Fibonacci.

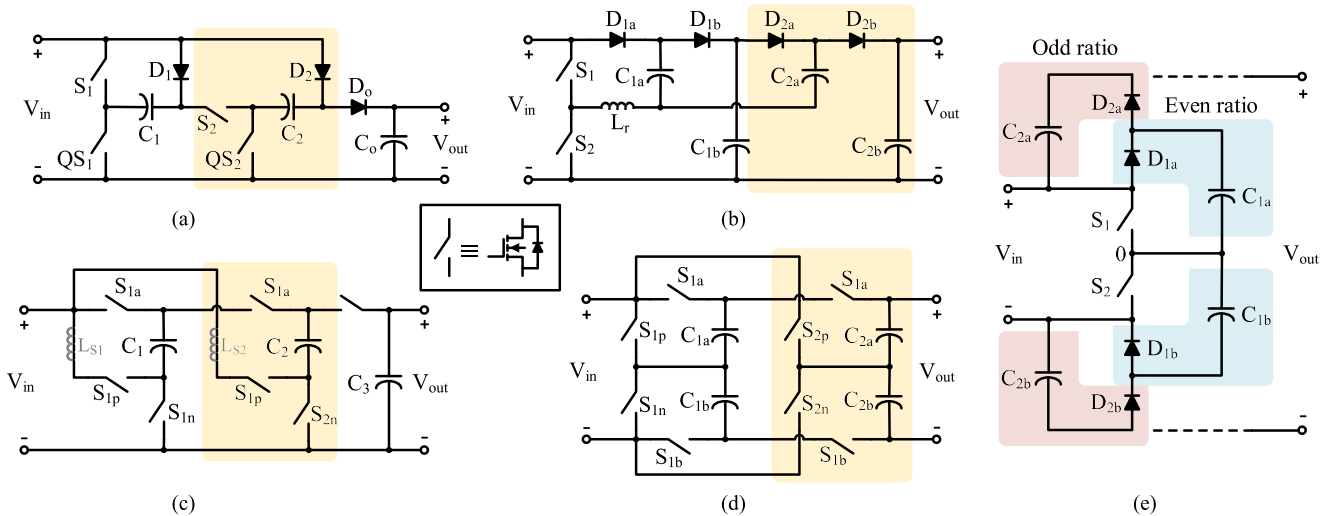

Fig. 10. Various switched capacitor dc–dc converters. (a), (b), and (e) are two switched capacitors with diode-capacitor stages. (c) and (d) are modular switched capacitors.

TABLE II
REQUIRED NUMBER OF DEVICES FOR SWITCHED CAPACITOR CONVERTERS WITH VOLTAGE GAIN 4

SC Converter	No. of Stages	No. of Switches	No. of Floating Capacitors	No. of Grounded Capacitors	No. of Diodes	Features
Converter in Fig. 10(a) [71]	3	6	3	1	4	<ul style="list-style-type: none"> Adjustable voltage conversion ratio. Continuous input current waveform.
Converter in Fig. 10(b) [132]	3	2	3	3	6	<ul style="list-style-type: none"> Zero current switching. Without current spike problem of SC circuits.
Converter in Fig. 10(c) [216]	3	10	3	1	0	<ul style="list-style-type: none"> The MMCCC topology provides autotransformer-like taps. Multiple load or DC source connection capability. On-board fault bypassing capability.
Converter in Fig. 10(d) [66]	2	8	4	0	0	<ul style="list-style-type: none"> Suitable for high voltage gain applications. Low power loss due to low current stress.
Converter in Fig. 10(e) [72]	3	2	6	0	6	<ul style="list-style-type: none"> Based on only two active switches with a simple control. Flexible gain extension for different gain applications.

The above-described SC converters attain only some low order of voltage multiplication. However, basic SC cells or modules are useful in converter structures. Fig. 10(d) shows a symmetrical modular SC dc–dc converter with a distributed total capacitor voltage rating. Owing to the modularity of its structure, this converter is capable of achieving high voltage gain but only requires low capacitance and voltage ratings for the output capacitors [66]. A new SC dc–dc converter with symmetrical diode capacitor cells introduced in [72] uses only two switches. This converter can provide flexible gain extension owing to its cell-based structure, simple switch control, and comparatively low-voltage stress on all devices. Table II shows the number of components required for a fourfold voltage SC converter described here.

B. Voltage Multiplier

Voltage multiplier circuits are efficient, low cost, and simple topologies typically comprising a set of diodes and capacitors to obtain high dc output voltage. From a structural point of view, they can be divided into two major groups: 1) the in-circuit VMC, which can be implemented in the middle of a circuit usually after the main switch, in order to reduce voltage stress; and 2) the voltage multiplier rectifier (VMR), which is placed at the output stage of transformer- and coupled-inductor-based structures in order to rectify ac or pulsating dc voltage while acting as a voltage multiplier.

1) *Voltage Multiplier Cell*: Voltage multiplier circuits are popular for high boost application as they are simple to implement in any circuit [49]. Fig. 11 shows some generic configurations known as VMC that can be found in dc–dc converters. It should be mentioned that some of these cells consist only of diodes and capacitors [see Fig. 11(b)–(d)] and hence are known in the literature as switched/diode capacitor VMCs [50], [51], [162]. Other VMCs have more components, such as an auxiliary switch [see Fig. 11(e)] [237], while some use inductors to increase the voltage-boosting ratio [see Fig. 11(f) and (g)] [50], [51], [73], [162], [163]. Some vertical implementations of the VMC in Fig. 11(c) can also be found in the literature [74], [164], [165].

The performance of the VMCs shown in Fig. 11(b)–(d) is similar and their voltage gain ratios are identical: $(1 + D)/(1 - D)$, where D is the duty ratio of the main switch. By using a small

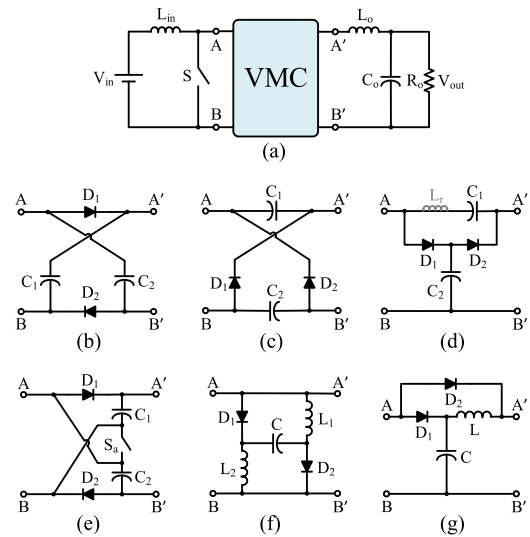

Fig. 11. (a) General topological view of the placement of voltage multiplier cells in step-up converters. (b)–(g) Various voltage multiplier cells.

inductor (normally between 1 and 4 μH) in the VMC in Fig. 11(d), a ZCS condition can be achieved for the main switch and diodes, which significantly reduces the power loss and increases the efficiency of the circuit [162]. All of the converters using VMCs shown in Fig. 11 operate by switching the main switch (S), with the exception of the VMC in Fig. 11(e) [163], in which the boost converter operates only with the switch S_a of the VMC.

The VMC in Fig. 11(f) uses a capacitor and inductors to increase the boost factor of the converters [73]. A horizontal implementation of this VMC was introduced in [75]. The VMC in Fig. 11(g) is typically inserted before the main switch to increase the voltage level of very low voltage sources (under 50 V). This VMC has been used in various ultrastep-up dc–dc converters [50]. To meet very high voltage gain demand, the VMCs in Fig. 11(b)–(d) can be implemented in series [162], [166]. In the VMC in Fig. 11(d), one inductor at the first stage is sufficient to achieve the ZVC condition on the main switch and in all diodes. A hybrid implementation of various voltage multipliers was also presented in [52]. As the proposed circuits use multiple VMCs, they can usually achieve ultravoltage gain

TABLE III
COMPARISON AMONG VARIOUS VOLTAGE MULTIPLIER CELLS

Voltage Multiplier Cell (VMC)	Voltage Gain Ratio (V_{out}/V_{in})	No. of Passive Elements	No. of Semiconductors
VMC in Fig. 11(b)	$\frac{1+D}{1-D}$	2 capacitors	2 diodes
VMC in Fig. 11(c)	$\frac{1+D}{1-D}$	2 capacitors	2 diodes
VMC in Fig. 11(d)	$\frac{1+D}{1-D}$	2 capacitors 1 inductor	2 diodes
VMC in Fig. 11(e)	$\frac{1+D}{1-D}$	1 capacitor	2 diodes 1 switch
VMC in Fig. 11(f)	$\frac{2+D}{1-D}$	2 inductors	2 diodes
VMC in Fig. 11(g)	$\frac{1}{1-D}$	1 capacitors 1 inductor	2 diodes

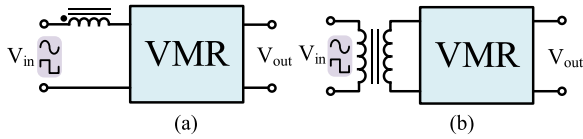

Fig. 12. General topological view of the placement of VMRs (a) at dc pulsating output and (b) at ac output.

with reduced stress on the components [76]. Table III presents a comparison between the voltage gain and component count of the VMCs described in this subsection.

2) *Voltage Multiplier Rectifier*: In the literature, this group is commonly referred to as voltage multipliers, and they consist solely of different configurations of diodes and capacitors. As these circuits can be used at the output stage of a converter with ac or pulsating dc inputs, they are also known as VMRs (see Fig. 12).

a) *Half-wave*: The broad group of half-wave VMRs is shown in Fig. 13. It should be noted that these circuits are not confined to the secondary side of isolated transformers and coupled inductors but can also be used in converters with built-in transformers and coupled inductors. Fig. 13(a) shows a Greinacher voltage doubler rectifier (G-VDR) which is well known and used at the output stage of many transformer-based dc–dc converters [230] and in multistage converters with modular series output [77]. The main drawback of this type of VMR is high-voltage stress on the diodes and output capacitor identical to the high output voltage. Fig. 13(b) shows an improved version of the G-VDR that was recently introduced [258]. The advantage of this VMR is that the voltage stresses of all components are half of the output voltage; this allows for the use of lower voltage rating components than in conventional VMRs, which in turn leads to low-power loss and high efficiency. Fig. 13(c) shows a Greinacher voltage quadrupler rectifier formed by connection of one normal and one inverted G-VDR. The advantage of this VMR is that it can provide a neutral point terminal, which is necessary for half bridge-based transformerless inverters [167].

Another well-known voltage multiplier is the Cockcroft–Walton (CW) voltage multiplier, which is similar to the G-VMR but was invented separately years after and earned its inventors

the 1951 Nobel Prize in Physics [29], [30]. CW-VMRs, as shown in Fig. 13(d), are popular for their simple cascading structures that can provide high-voltage levels [168]. In the generalized CW-VMR shown in Fig. 13(e), the up and down capacitors are used for odd and even multiplication, respectively. Various cascaded CW-VMR structures for very high output voltage applications can be found in the literature [45], [169], [170].

b) *Full-wave*: Full-wave VMRs, another well-known type of independent boosting stage, are commonly employed at the output stage of transformer-based converters. Fig. 14 illustrates some basic and generalized structures for even and odd voltage multiplier groups. The VMR in Fig. 14(a) is a full-bridge voltage doubler rectifier that, owing to its reduced voltage stress on output capacitors (it reduces the output voltage by one-half), is commonly used in various dc–dc converters [78], [210], [231], [246], [264]. The VMR in Fig. 14(b) is a quadrupler voltage rectifier that is considered to be a useful boosting stage in modern dc–dc converters owing to its balanced voltage stress on both capacitors and diodes [262], [274]. Fig. 14(c) shows a multi-stage structure consisting of the VMRs in Fig. 14(a) and (b) (even group) [249]. The VMR in Fig. 14(d) is a voltage tripler rectifier that is used in many ultrastep-up dc–dc converters. This VMR can be found in isolated [242] or in multilevel output series structures [79].

The VMR in Fig. 14(e) features a series connection of introduced on the secondary winding of the coupled inductor [80]. Some high-order VMR modules of this type are presented in [275] as up to ninefold voltage multipliers. A generalized form of this VMR is shown in Fig. 14(f). Although the voltage stresses in the middle stages are reduced, the voltage stress of the output diode and capacitor remain identical to the high output voltage level. However, high-order multiplication may result in increased power loss, cost, and circuit size. Table IV summarizes the voltage stresses on the diodes and capacitors of various VMRs.

C. Switched Inductor and Voltage Lift

The VL technique is another useful method that is broadly used in dc–dc converters to increase output voltage level. This technique is based on charging a capacitor to a certain voltage (e.g., input voltage) and then stepping up the output voltage (lifting voltage) with the voltage level of the charged capacitor. By repeating this operation with the inclusion of additional capacitors to create the so-called relift, triple-lift, and quadruple-lift circuits, the output voltage level can be further increased [81]–[101]. Many step-up dc–dc converters have been introduced by Luo (VL Luo converters) [81], [82], and the VL technique has been applied in the literature to a number of converters, namely Ćuk, SEPIC, and Zeta converters [83]. To further increase the VL, a multiple-lift circuit using an n -stage basic diode capacitor VL circuit was demonstrated in [171].

The VL techniques can also be used in VL cells in step-up dc–dc converters. Voltage lift switched inductor (VL-SL) cells are shown in Fig. 15, with a typical placement of these cells in a step-up dc–dc converter shown in Fig. 15(a). The basic SL cell depicted in Fig. 15(b) was first introduced in [51]. In an SL cell, the inductors are magnetized in parallel and demag-

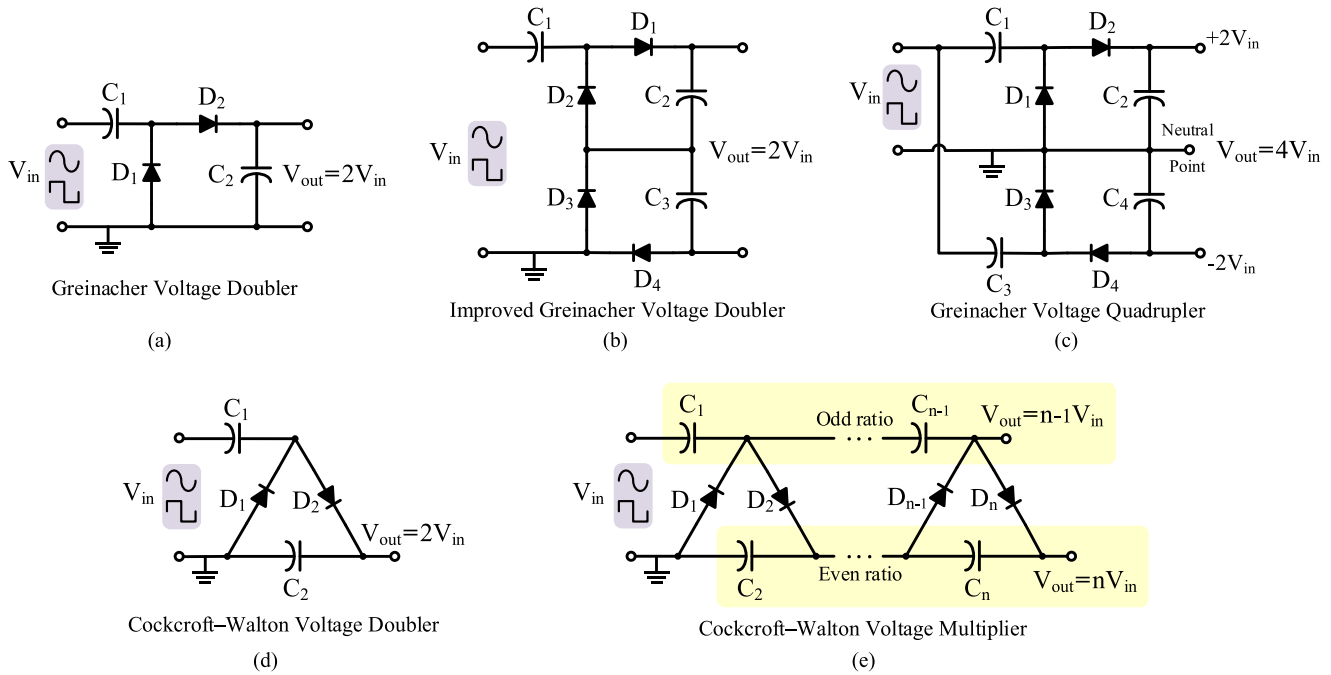

Fig. 13. Various half-wave VMRs. (a) Greinacher voltage doubler. (b) Improved Greinacher voltage doubler. (c) Greinacher voltage quadrupler. (d) CW voltage doubler. (e) CW voltage multiplier.

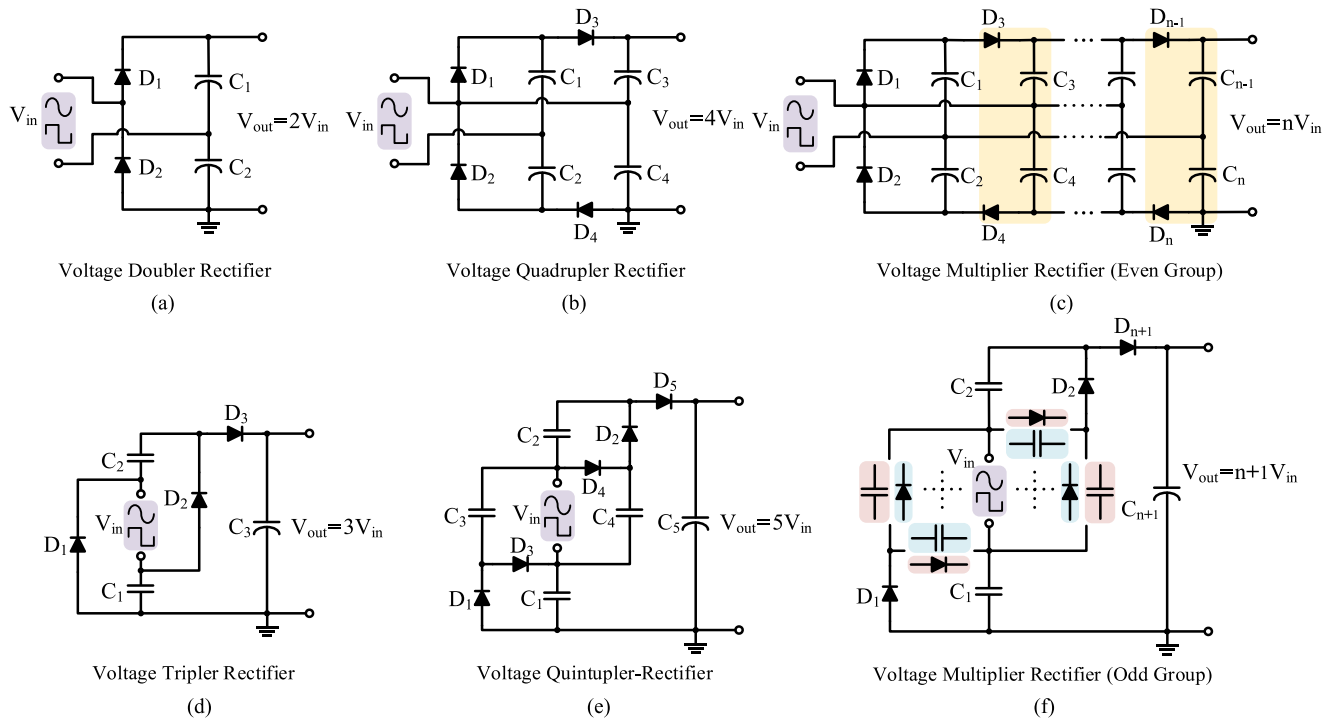

Fig. 14. Various full-wave VMRs. (a) Voltage doubler rectifier. (b) Voltage quadrupler rectifier. (c) VMR (even group). (d) Voltage tripler rectifier. (e) Voltage quintupler rectifier. (f) VMR (odd group).

netized in series. As both inductors have the same inductance value and operational condition, they can be integrated into a single core in order to reduce the size and weight of the converter. The elementary circuit of a VL circuit is shown in Fig. 15(c). The VL cell has been implemented in various structures

[85], [86]. Recently, Ye and Cheng [87] introduced a small resonant inductor (under $1 \mu\text{H}$) to the circuit of a basic VL cell and by varying the placement of the components produced some novel high conversion ratio dc-dc converters that benefit from simple structures and high efficiency.

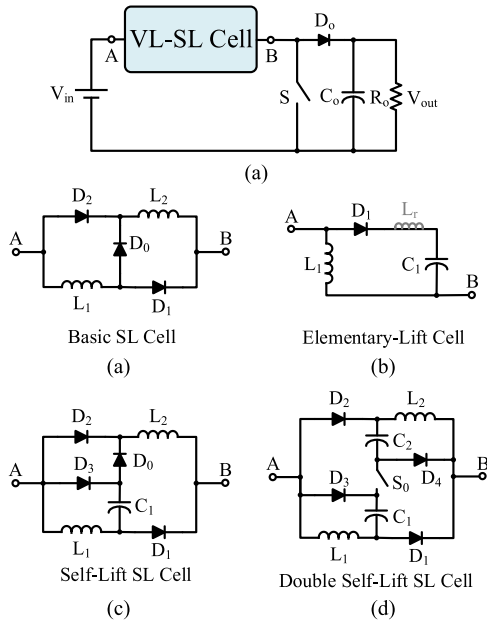

Fig. 15. Voltage lift cells. (a) General placement of the voltage lift cell in step-up converters. (b)–(e) Various voltage lift switched inductor cells. [(a) Basic SL cell. (b) Elementary-lift cell. (c) Self-lift SL cell. (d) Double self-lift SL cell.]

TABLE IV
VOLTAGE STRESS FOR VARIOUS VMRS

Voltage Multiplier Rectifier (VMR)	Output Voltage (V_{out})	Output Diode Voltage Stress	Output Capacitor Voltage Stress
Greinacher Voltage Doubler	$2 V_{in}$	V_{out}	V_{out}
Improved Greinacher Voltage Doubler	$2 V_{in}$	$\frac{V_{out}}{2}$	$\frac{V_{out}}{2}$
Greinacher Voltage Quadrupler	$4 V_{in}$	$\frac{V_{out}}{2}$	$\frac{V_{out}}{2}$
Cockcroft-Walton Voltage Multiplier	$n V_{in}$	V_{out}	V_{out}
Voltage Doubler Rectifier	$2 V_{in}$	V_{out}	$\frac{V_{out}}{2}$
Voltage Tripler Rectifier	$3 V_{in}$	V_{out}	V_{out}
Voltage Quadrupler Rectifier	$4 V_{in}$	$\frac{V_{out}}{2}$	$\frac{V_{out}}{2}$
Voltage Quintupler Rectifier	$5 V_{in}$	V_{out}	V_{out}

Implementing an elementary VL cell in an SL cell produces the so-called self-lift SL cell, as shown in Fig. 15(d). Adding another diode and capacitor to a self-lift SL cell produces a double self-lift SL cell, as shown in Fig. 15(e) [85]. In a double self-lift SL cell, S_0 is used instead of D_0 in a basic SL cell with switching operation complementary to the switch S in Fig. 15(a). Some high-order SL-based converters that can obtain high voltage gain can be found in the literature [86], [88]. A generalized structure with an n -stage VL cell, called the superlift SL, was introduced in [89]. Luo and Ye [90] introduced several superlift SL converters for obtaining high-voltage-gain ratios. Table V presents a comparison between some of the parameters in the abovementioned VL-SL cells.

TABLE V
COMPARISON AMONG DIFFERENT A-SL CIRCUITS

Voltage Lift Cells	Basic SL Cell	Elementary-Lift Cell	Self-Lift SL Cell	Double Self-Lift SL Cell
No. of Semiconductors	3 diode	1 diode	4 diodes	4 diode 1 switch
No. Passive Elements	2 inductors	1 inductor 1 capacitor	2 inductors 1 capacitor	2 inductors 2 capacitors
Voltage Gain	$\frac{1+D}{1-D}$	$\frac{2-D}{1-D}$	$\frac{2}{1-D}$	$\frac{3-D}{1-D}$

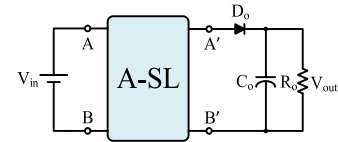

Fig. 16. General topological view of an A-SL circuit (AN SL) in a step-up converter.

An active switched inductor (A-SL) based converter was presented in [91]. Instead of three diodes, as in the basic SL cell shown in Fig. 15(a), only two active switches are used in an A-SL network and there is no need for an external switch in the converter circuit. In the recent literature [92], [93], converters that include this structure have often been called AN converters. ANs can be placed in a step-up dc–dc converter such as the one in Fig. 16. Various A-SL networks are shown in Fig. 17. In [91], an improved A-SL network that obtains increased voltage gain through the use of extra diodes and capacitors and reduces the voltage stress across S_1 and S_2 was introduced. A hybrid A-SL network was presented in [92]. Although it increases the voltage gain in the duty cycles to over 0.5, the voltage stress across the switch and the number of diodes are also increased. In the ANs shown in Fig. 17(a)–(c), the shared operation of inductors allow for integration into a single core to potentially decrease the size and weight of the converters [92].

A quasi active switched inductor (QA-SL) with a coupled inductor was introduced in [94]. QA-SLs can provide high voltage gain and low-voltage stress on S_1 and S_2 with a small coupled-inductor core size. The voltage gain of a QA-SL network can be increased by increasing the turns ratio of the coupled inductor. To reduce the voltage spike on the power switches and increase the voltage gain, two diodes and two capacitors are employed in the improved QA-SL network shown Fig. 17(e). Another coupled-inductor-based AN [95] is shown in Fig. 17(f). This AN employs one less diode and capacitor than the improved AQ-SL while retaining the other features. Fig. 17(g) shows another AN [93], which uses two more diodes and two fewer passive components (capacitors) than the improved QA-SL. In this design, the voltage stress on the power switches is higher than in the improved QA-SL while the obtained voltage gains are identical. Table VI presents a comparison between some major parameters of A-SL networks.

Other coupled-inductor-based SLs, referred to as switched coupled inductors (S-CL), have been presented in the literature. Fig. 18(a) shows an S-CL boost converter, which has a higher voltage gain than a boost converter and also recycles leakage energy to the load [96], [97]. The S-CL circuit consists of three

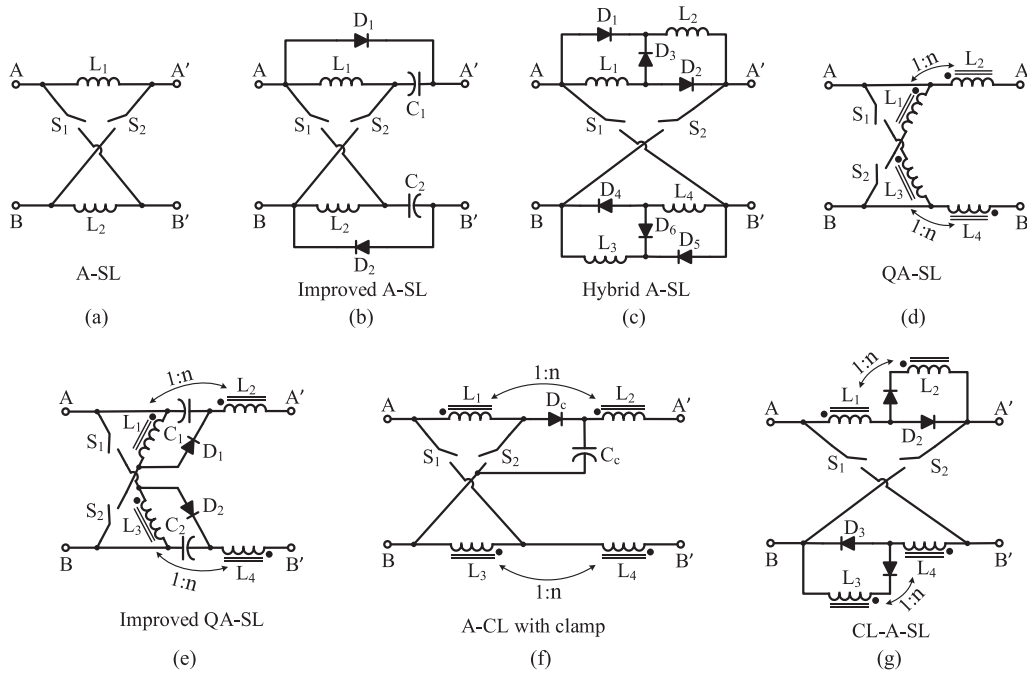

Fig. 17. Various A-SL circuits (AN SL). (a) A-SL. (b) Improved A-SL. (c) Hybrid A-SL. (d) QA-SL. (e) Improved QA-SL. (f) A-CL with clamp. (g) CL-A-SL.

TABLE VI
COMPARISON AMONG DIFFERENT A-SL CIRCUITS

Active Switch Inductor	A-SL	Improved A-SL	Hybrid A-SL	QA-SL	Improved QA-SL	A-CL with clamp	CL-A-SL
No. of switches	2	2	2	2	2	2	2
No. of diodes	0	2	6	0	2	1	4
No. of passive elements	2 inductors	2 inductors 2 capacitors	4 inductors	4 coupled inductors	4 coupled inductors 2 capacitors	4 coupled inductors 1 capacitor	4 coupled inductors
Voltage gain	$\frac{1+D}{1-D}$	$\frac{3-D}{1-D}$	$\frac{1+3D}{1-D}$	$\frac{1+(2n-1)D}{1-D}$	$\frac{1+(2n+1)D}{1-D}$	$\frac{1+(2n+1)D}{1-D}$	$\frac{1+(2n+1)D}{1-D}$
Voltage stress of switches	$\frac{V_{out}}{1+D}$	$\frac{V_{out}}{3-D}$	$\frac{(0.5+D)V_{out}}{1+3D}$	$\frac{V_{out}}{1+(2n+1)D}$	$\frac{V_{out}}{1+(2n+1)D}$	$\frac{V_{out}}{1+(2n+1)D}$	$\frac{(1+nD)V_{out}}{1+(2n+1)D}$

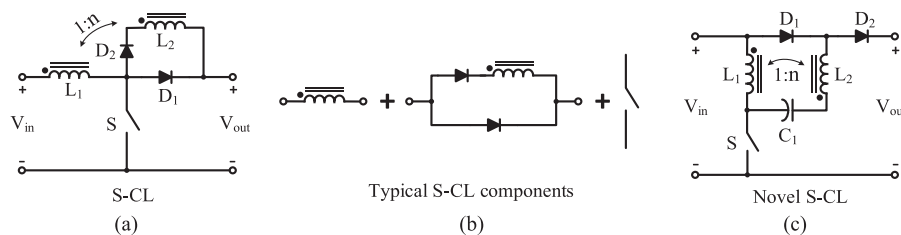

Fig. 18. Switched coupled inductor. (a) S-CL boost converter. (b) Typical S-CL components used in various converters. (c) Novel S-CL.

components, as shown as Fig. 18(b). These components have also been implemented in various other converters (buck–boost, Ćuk, SPEIC, and Zeta converters) [98]–[100]. Fig. 18(c) shows a novel, recently introduced S-CL converter [101]; multiple, interleaved, and bidirectional topologies of this converter can be found in [101].

D. Magnetic Coupling

Magnetic coupling is a popular voltage-boosting technique that is used in both isolated and nonisolated dc–dc converters.

Using a coupled inductor reduces the number of magnetic cores, which are often the bulkiest components in the layout. Despite benefits such as dominant boost ability, utilization of magnetic coupling is often incurs drawbacks such as leakage inductance that may require consideration in terms of recycling the leakage energy. In this section, the various transformer-based boost techniques, as well as the inductor coupling technique, are presented.

1) *Transformer*: Transformer-based dc–dc converters are the subject of increasing research interest as the transformer turns ratio provides an additional degree of design freedom that,

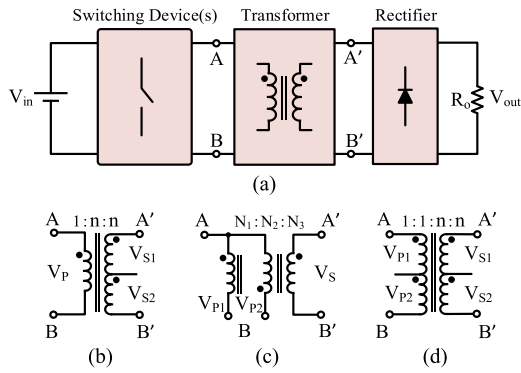

Fig. 19. Isolated dc–dc converters. (a) General layout of basic transformer-based converters. (b) Full bridge/half bridge. (c) Forward. (d) Push–pull.

along with the duty cycle, can be manipulated to achieve high-voltage boost ability. Transformer converters can be broken into two types: isolated transformers, which are used to electrically isolate dc–dc converters; and nonisolated dc–dc converters derived from isolated converters, which are known in the literature as built-in transformers. Although their underlying circuit theories are similar; however, the performance differs by type.

a) Isolated transformers: Fig. 19(a) shows a schematic of a basic transformer-based converter with an input dc source followed by a network of switches, diodes, and transformer that is then rectified and connected to an output filter. There are several common types of isolation transformers that can be incorporated into dc–dc converters according to their switching network layouts [4], [5]. Full- and half-bridge converters typically use a transformer of the type shown in Fig. 19(b), in which one or two windings in the secondary (depending on the rectifier circuit) are used to step-up the primary voltage. One type of buck-based converter called the forward converter incorporates a three winding transformer, as shown in Fig. 19(c). Push–pull-based converters typically use a multiwinding transformer, as shown in Fig. 19(d), in which the two windings in the primary (each one activating in a switching state) are followed by one or two windings in the secondary (depending on the rectifier circuit).

With the goal of enhancing boost ability or optimizing other features, a number of studies have focused on developing new types of dc–dc converters, including impedance (Z -) source-based isolated dc–dc converters, DAB topologies, dual-half-bridge topologies, etc. [226], [229]–[231], [249], [265], [266], [280], [287]–[288], [295]–[297]. It is worth mentioning that the operation of a converter containing transformers should be investigated using a complete model of the transformer that contains magnetizing inductance and the leakage inductances of the windings. This implies that some additional features in transformer-based converters should be considered, e.g., the dc component of the voltage across the magnetizing inductance must be zero to avoid the core saturation. Leakage inductance can also cause problems such as switching losses or voltage spikes across the switching devices; however, these effects might be useful in some soft-switching techniques [257]. Indeed, the tolerance of transformer nonidealities makes resonant

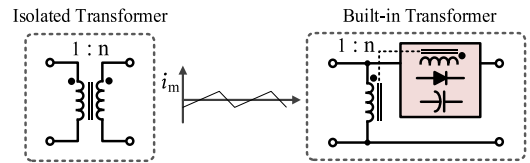

Fig. 20. General law of an isolated transformer to built-in transformer derivation.

transformer isolated dc–dc converters such as LLC type usable in high-voltage applications [139], [218], [227], [247]–[249], [290], [297]. These converters incorporate transformer nonidealities (i.e., leakage inductance and winding capacitance) into the basic operation of the circuit as parts of a resonant tank. Soft-switching current-fed converters such as dual inductor-fed and full-bridge current converters are another common solution for many high step-up applications [267]–[268].

b) Built-in transformers: The use of built-in transformer (also known as the transformer-assisted concept) is another approach for using magnetic elements in high step-up dc–dc converters [130], [205]–[211]. This concept is derived from the idea of deriving nonisolated circuits from isolated circuits using direct energy transfer. As shown in Fig. 20, one part of the load energy is directly delivered from the input source and the other is transferred through the magnetic coupling using voltage multipliers in order to enhance the boosting factor and improve the efficiency. The advantage of a built-in transformer is that there is balanced magnetic flux in the core, which allows for small core utilization owing to the inherent saturation avoidance [211].

Some examples of general built-in transformer-based converter structures are shown in Fig. 21. The primary side of such converters usually consists of switched networks to generate pulsating dc voltage, while the secondary side usually consists of SCs voltage multiplier modules [130], [208]–[210]. In addition to the transformer shown in these circuits, various voltage multiplier circuits are used to further increase the voltage gain and reduce the built-in transformer turns ratio. With the help of the leakage inductance at the primary winding and the small dc blocking capacitor found in most of these circuits, quasi-resonant operation is obtained, which in turn increases efficiency. Fig. 21(c) shows a high step-up dc–dc converter utilizing both coupled inductor and built-in transformer techniques. The turn ratios of the coupled-inductor and transformer introduce two additional control variables to extend the voltage gain and improve performance [210]. A further combination of quadratic boost and built-in transformer voltage multiplier techniques to obtain a high voltage can be found in [153].

2) Coupled Inductor: Coupled inductors are a valuable component of nonisolated dc–dc converters that store energy in one cycle and power the load in the other cycles. As many applications do not require electrical isolation, the use of coupled inductors provides a helpful alternative boosting technique in dc–dc converters that can be achieved by tapping or simply coupling the inductors.

a) Tapped inductor/autotransformer: Tapped circuits can be categorized into three types: switched-tapped, diode-tapped, and rail-tapped. Fig. 22(a) shows the general configuration of

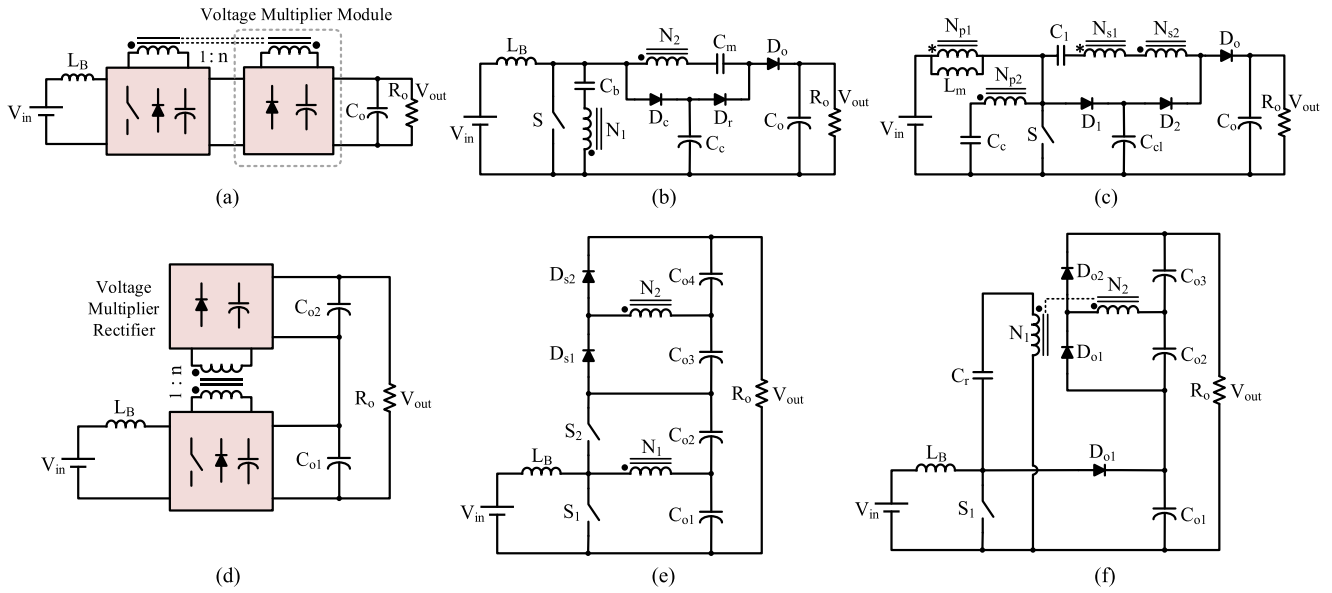

Fig. 21. Step-up dc–dc converter consisting of built-in transformer concept. (a) General layout with the horizontal structure. (b) Comprising voltage multiplier [207]. (c) Comprising both coupled inductor and built-in transformer [130]. (d) General layout with the vertical structure. (e) Boost integrated stacked converter [208]. (f) Integrated with a transformer-assisted auxiliary circuit [210].

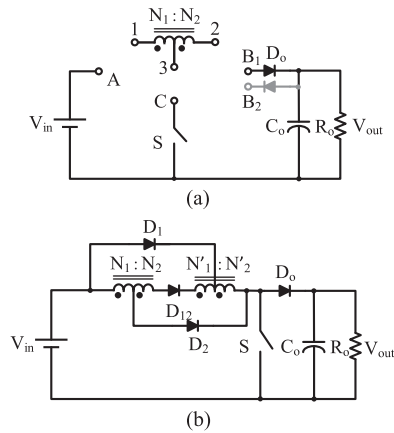

Fig. 22. Tapped-inductor based converters. (a) General configuration of a tapped inductor boost converter and (b) double-tapped inductor boost converter.

a tapped-inductor boost dc–dc converter [102], [103]. Switch tapping occurs by connecting A to 1, B1 to 2, and C to 3. Diode-tapping is obtained by connecting A to 1, B1 to 3, and C to 2. Finally, the circuit can be rail-tapped by connecting A to 3, B2 to 2, and C to 1. It should be mentioned that the coupling connection of tapped inductors can be in either cumulative [as shown in Fig. 22(a)] or differential form. A complete overview of basic tapped inductor dc–dc converters, including buck, boost, and buck–boost converters, can be found in [46] and [104]. Tapped inductor techniques can be applied in multiple stages, as shown in Fig. 22(b). A double-tapped inductor boost converter has been proposed [105] to reduce the turns ratio while maintaining higher boosting ability. Table VII shows a comparison between the obtained voltage gains of various tapped-inductor dc–dc converters, where n for a double-tapped-inductor boost converter can be defined as $N_1/(N_1 + N_2)$ or $N'_1/(N'_1 + N'_2)$.

TABLE VII
COMPARISON AMONG GAINS OF DIFFERENT TAPPED INDUCTOR-BASED CONVERTERS

Converter	Switched-Tapped	Diode-Tapped	Rail-Tapped
Buck	$\frac{D}{D(1-n) + n}$	$\frac{nD}{1 + D(n-1)}$	$\frac{D-n}{D(1-n)}$
Boost	$\frac{n + D(1-n)}{n(1-D)}$	$\frac{1 + D(n-1)}{1-D}$	$\frac{n-D}{n(1-D)}$
Buck-boost	$\frac{-D}{n(1-D)}$	$\frac{-nD}{1-D}$	$\frac{(1-n)D}{n(1-D)}$

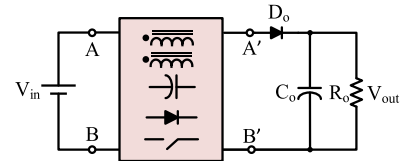

Fig. 23. General layout of the coupled-inductor-based step-up converter.

Parasitic analysis shows that the gain voltage and efficiency of tapped inductor boost converters can be theoretically higher than that of PWM boost dc–dc converters. On the other hand, as the root mean square (RMS) current of the switches, RMS current of inductors, and diode-blocking voltages all increase when inductor tapping is utilized [106], designing a clamp/snubber circuit is sometimes necessary [102] and [107]. Another advantageous use of tapped inductors is obtaining input current ripple cancellation in a PWM boost dc–dc converter, as demonstrated in [172].

b) Magnetically coupled-based converters: Fig. 23 shows the general configuration of a coupled-inductor-based boost converter. A basic coupled-inductor boost converter is shown in Fig. 24(a). The secondary winding acts as a voltage source in series with the power branch, while the clamp capacitor C_c and

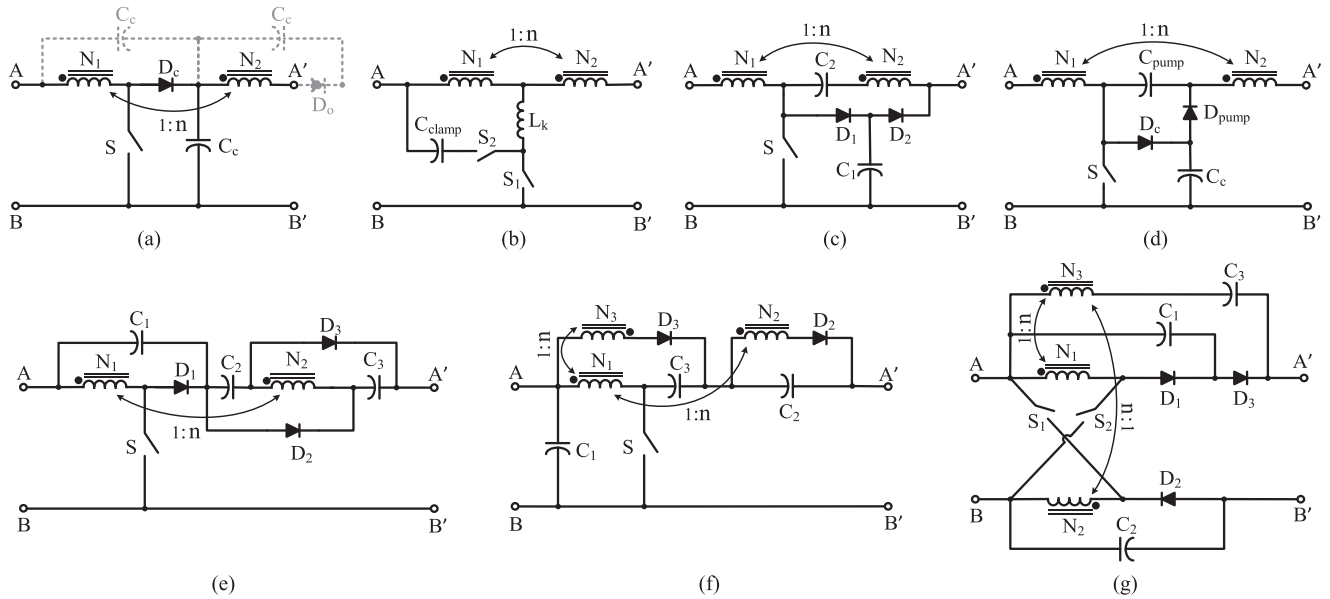

Fig. 24. Coupled-inductor-based circuits. (a) Basic coupled inductor. (b) Switched coupled inductor. (c) Coupled inductor with active clamp. (d) Coupled inductor with a snubber circuit. (e) High step-up. (f) Three-winding dual switch.

TABLE VIII
SUMMARY OF COUPLED-INDUCTOR-BASED CIRCUITS

Coupled-Inductor Based Circuit	Voltage Gain* (V_{out}/V_{in})	Voltage Stress on the Switching Device*	No. of Semiconductors		No. of Passive Components		Features
			Diode	Switch	Capacitor	Inductor	
Coupled inductor boost converter [108]	$\frac{D(n+1)}{1-D}$	$\frac{V_{out}}{D(n+1)}$	1	1	1	2 coupled	<ul style="list-style-type: none"> Basic coupled inductor boost converter. Utilizing clamp circuit to absorb leakage energy.
Coupled inductor with active clamp [136]	$\frac{nD+1}{1-D}$	$\frac{V_{out}}{nD+1}$	0	2	1	2 coupled 1 normal	<ul style="list-style-type: none"> Active clamp with voltage spike elimination. ZVS of the switches and ZCS of output diode. High efficiency.
Coupled inductor with snubber [109]	$\frac{2+n}{1-D}$	$\frac{V_{out}}{2+n}$	2	1	2	2 coupled	<ul style="list-style-type: none"> Auxiliary boosting circuit with snubber effect on the main switch. Low reverse-recovery of output diode.
Coupled inductor with charge pump [110]	$\frac{2+nD}{1-D}$	$\frac{V_{out}}{2+nD}$	2	1	2	2 coupled	<ul style="list-style-type: none"> Wide input range and high voltage gain. Low voltage and current stress on components.
High step-up coupled inductor [111]	$\frac{1+n+nD}{1-D}$	$\frac{V_{out}}{1+n+nD}$	3	1	3	2 coupled	<ul style="list-style-type: none"> High step-up ability with voltage clamp mode. Low Voltage stress on semiconductors.
Three winding with reduced switch stress [112]	$\frac{1+n+D}{1-D}$	$\frac{V_{out}}{1+n+D}$	2	1	3	3 coupled	<ul style="list-style-type: none"> High boost ability and high efficiency with three coupled windings. Minimized duty cycle of the switch.
Three winding dual switch [137]	$\frac{1+n+D}{1-D}$	$\frac{V_{out}}{1+n+D}$	3	2	3	3 coupled	<ul style="list-style-type: none"> High boost ability using three windings. Reduced voltage/current stress of the switches. ZCS operation of the diodes.
Magnetically Coupled Impedance Networks							
Trans-Z-source [31]	$\frac{1}{1-(1+n)D}$	V_{out}	1	1	1	2 coupled	<ul style="list-style-type: none"> Gain raise by increasing turns ratio. Very high voltage gain with small duty cycle. High voltage stress on the switch.
Γ -source [31]	$\frac{1}{1-(1+\frac{1}{n-1})D}$	V_{out}	1	1	1	2 coupled	<ul style="list-style-type: none"> Gain raise by decreasing turns ratio. Very high voltage gain with small duty cycle. High voltage stress on the switch.
Y-source [113]	$\frac{1}{[1-(\frac{N_3+N_1}{N_3-N_2})D]}$	V_{out}	1	1	1	3 coupled 1 normal	<ul style="list-style-type: none"> Gain raise by both increasing and decreasing turns ratios with high degree of design freedom. Very high boost ability with small duty cycle. High voltage stress on the switch.
Quasi-Y-source [173]	$\frac{1}{[1-(\frac{N_1+N_2}{N_2-N_3})D]}$	V_{out}	1	1	2	3 coupled	<ul style="list-style-type: none"> Continuous input current characteristics. Very high boost ability with small duty cycle. High voltage stress on the switch.

*The leakage inductance is neglected in the equations.

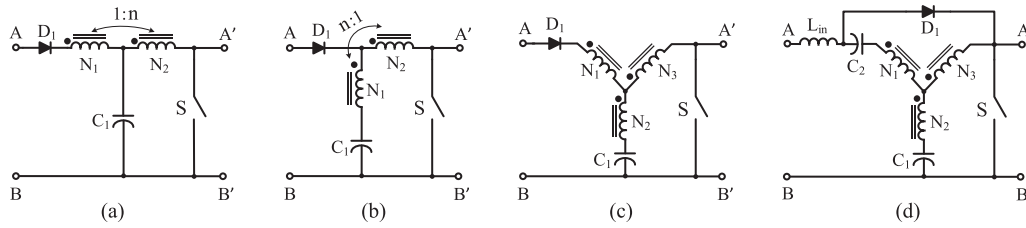

Fig. 25. Various magnetically coupled impedance source networks. (a) Trans-Z-source. (b) Γ -source. (c) Y-source. (d) Quasi-Y-source.

diode D_c are used to recover leakage energy. The clamp capacitor can be shifted within the circuit. The clamping function is similar in all placements and the leakage energy can be effectively recycled directly or through the secondary winding to the load [108].

Passive clamping may not effectively eliminate switch voltage spiking, and several solutions have been proposed to address this problem. In the active-clamp assisted circuit illustrated in Fig. 24(b), the voltage spike is reduced using the soft-switching technique, which leads to higher efficiency and lower voltage stress on the devices [136]. A snubber circuit can also be used to absorb the energy of leakage inductance and to improve efficiency [109]. A proposed circuit using this assumption is shown in Fig. 24(c). Both the CP and the passive clamp circuit can be used on a basic boost coupled-inductor converter to increase the voltage gain and reduce the voltage stress on the main switch [see Fig. 24(d)] [110].

By using charge pumping and SC voltage multiplier methods in a coupled inductor, a high step-up gain, which is desirable in distributed generation (DG), can be achieved [111]. An example of this technique is shown in Fig. 24(e), in which two capacitors are charged in parallel and discharged in series by a coupled inductor. A three-winding coupled inductor can be useful in situations in which higher voltage conversion is required. Fig. 24(f) shows a typical application of the three-winding boosting technique. Using the method described in [112] with added high boost ability reduces the switch conduction time, which in turn leads to a lower conducting loss. In addition, the leakage energy is recycled by the output. The reverse-recovery problem can be solved by the manipulation of the delay time by crossing the primary and secondary currents of a coupled inductor. Fig. 24(g) shows a dual-switch three-winding coupled-inductor-based boost circuit integrated with a CP; utilizing two switches helps this circuit reduce the voltage and current stress. An active clamp is present to ensure ZVS and improve efficiency [137]. As mentioned previously, all dc–dc converters with magnetic coupling are vulnerable to the detrimental effects of the leakage inductance, i.e., voltage ringing and high spiking on semiconductors. However, leakage inductance can also be used to benefit converter performance by adding a small capacitor in series with the primary or secondary of the coupled inductor in order to form a resonant circuit with the leakage inductor and produce a soft-switching (ZVS and/or ZCS) condition [203], [204], [207], [210].

The emergence of impedance-network-based power converters has opened another field of voltage-boosting techniques.

Many magnetically coupled impedance networks have been introduced in the literature with the goal of improving the voltage boost ability power converters: these include trans-Z source and Γ -source networks [20] and [31]. The galvanically isolated structure of dc–dc impedance source-based converters is also receiving increased attention [226]. In a trans-Z-source impedance network, as shown in Fig. 25(a), a coupled inductor is used to increase the voltage gain. Fig. 25(b) shows a Γ -source impedance network that also utilizes a coupled inductor. The voltage gain of a trans-Z-source structure increases by increasing the turns ratio, while in a Γ -Z-source structure gain increases by decreasing the turns ratio. A three-winding coupled-inductor-based dc–dc converter that employs a novel impedance network derived from the abovementioned impedance-network designs was introduced in [113]. Fig. 25(c) shows a Y-source impedance network, which has more design degrees of freedom than its counterparts. A continuous input current version of this converter, called a quasi-Y-source dc–dc converter, is shown in Fig. 25(d) [173]. Using dc blocking capacitors in series with the coupled inductor, this circuit effectively avoids core saturation. Another variant of these types of dc–dc converter with continuous input current and dc blocking capacitors can be found in [174], in which the voltage gain is increased by reducing the magnetic turns ratio, and additional quasi-types of magnetically coupled impedance source can also be found in the literature [31]. A comparison among the different coupled-inductor dc–dc converters is presented in Table VIII.

Boosting the voltage using a coupled inductor is still an active area of study, and many new methods are being proposed to improve existing configurations or integrate the coupling technique with other techniques [114], [115], [175], [208], [231]. It can be inferred from the literature that, when dealing with high step-up gain and a wide operating range, at least one part of a multistage power conversion structure should be based on coupled magnetics in order to reduce component stress. For instance, the hybrid switched-capacitor/magnetics circuit structure proposed in [277] and called the MultiTrack architecture splits the wide voltage conversion range into multiple smaller ranges. This circuit relies on the combination of several voltage-boosting techniques, i.e., switched-inductor, multiphase (interleaved), switched-capacitor, and magnetic coupling. Indeed, the MultiTrack architecture is a proper example of how several boosting techniques can be merged in order to produce high step-up gain with distributed voltage and current stresses and increased integration/power density.

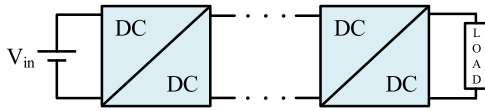

Fig. 26. General layout of the cascaded dc–dc converter.

E. Multistage-/Level

One well-known method for increasing the voltage gain of a dc–dc converter is to employ several stages of converter modules connected in various ways. This can be realized by implementing several identical/different converter modules combined with various voltage-boosting techniques. In this subsection, cascaded, interleaved, and multilevel converter topologies and their sub groups are presented. The voltage gain in multistage-/level structures increases linearly or exponentially (often multiplicatively by number of stages) as a function of the topology used.

1) *Cascaded*: Cascading connection of converters is a simple approach for increasing voltage gain. Fig. 26 shows a schematic of a cascaded dc–dc converter [25]. According to the depicted scheme, two or more boost converters can be connected in cascaded form (called a quadratic group) or different types of step-up converters can be connected in cascaded form (called a hybrid group).

a) *Quadratic boost*: Fig. 27(a) shows a cascaded boost converter consisting of two boost converters in cascaded form [44]. The voltage stress on the first stage is relatively low, and it can be operated in high frequency; hence, it benefits from high power density. By contrast, the second stage can be operated at a low frequency to reduce the switching loss. A multistate version of this converter with several cascaded boost converters is presented in [140]. To reduce the circuit complexity, the switches of the cascaded boost converter can be integrated into one switch. In a structure called a quadratic boost converter [141]. A possible drawback of quadratic boost converters is that the duty ratios of the two boost stages can no longer be independently controlled, unlike in topologies such as in Fig. 27(a). The configuration of a quadratic boost converter is shown in Fig. 27(b). A multistage version of this converter with several voltage-boosting modules and only one switch is presented in [142]. Fig. 27(c) shows a three-level quadratic dc–dc converter that was introduced for high-voltage-gain applications [143]. Several basic quadratic boost converter structures are shown in Fig. 27(d)–(g) [16]. Quadratic boost converters can operate with wider ranges of voltage gain than those of PWM boost dc–dc converters. For applications in which the voltage gain is limited, quadratic boost converters can operate with narrower variations in the duty cycle than those in PWM boost dc–dc converters, which simplifies the design procedure and improves performance [144]. Moreover, quadratic boost converters are advantageous for low-power applications where sophisticated magnetic designs are avoided.

Fig. 27(d) shows a quadratic boost converter with low capacitor voltage stress [145]. In Fig. 27(e) and (f), two quadratic boost converters with the same components that only differ in terms of the buffer capacitor placement are shown [146]. Several modi-

fications have been added to the basic quadratic boost converter schematic. A quasi-resonant quadratic boost converter that increases efficiency was introduced in [204]. In [147], a quadratic boost converter with an active clamp to reduce the voltage spike on the switches was introduced. In general, cascaded boost-type converters, such as those in Fig. 27, usually have four switches, with at least one of them active. They may also contain a single inductor and capacitor for each stage of the converter: for example, two stage cascades tend to have two inductors and two capacitors in their circuits.

b) *Hybrid cascaded*: In this subsection, two types of cascaded converters are introduced: quadratic boost-based converters with auxiliary circuits, and hybrid connections of two different types of dc–dc converters. Fig. 28(a) shows the general structure of a hybrid cascaded connection of quadratic boost and voltage multiplier modules. In [148] and [149], some cascaded dc–dc converters with quadratic boosting in the first stage, coupled-inductor modules in the second stage, and output series connection were presented. In [150]–[152], various combinations of quadratic boost and coupled-inductor techniques were used to achieve high voltage gain. Combinations quadratic boost converters with various VMCs can be found in [153]–[155]. With the aid of voltage multiplier circuits, the voltage gain of these quadratic boost based converters are high enough to fulfill high-voltage applications. Fig. 28(b) and (c) shows examples of dc–dc converters with quadratic boosting in the first stage.

Fig. 28(d) shows the general structure of a hybrid cascaded two different dc–dc converter. A synthesis of a family of ZVS dc–dc converters with fundamental PWM converters was presented in [32]. In [155], some combinations of quadratic boost and Zeta converters were presented. In [156], the cascaded connection of a quadratic boost converter and a forward converter is presented. In converters such as these, the cascaded connection of various converters often allows for a high boost ratio using small passive components. A hybrid cascaded connection of an interleaved and a three-level boost converter, as shown in Fig. 28(e), was introduced in [157]. The cascaded connection of a boost converter with a buck-boost converter [see Fig. 28(f)] and with a half-bridge converter with two quadrant chopper was presented in [158] and [218], respectively. These examples show the potential of the cascading concept in various topologies with different voltage-boosting techniques. Depending on the implementation, such topologies may incorporate more switches than traditional cascade structures and may therefore have higher costs commensurate with their parts count.

2) *Interleaved*: In step-up dc–dc converters, the input current level is higher than the output current level. As such, the multiphase interleaving technique is a promising solution for decreasing the current ripple and increasing the power density in high step-up dc–dc converters. Fig. 29(a) shows a schematic of a two-phase interleaved boost converter. In addition to zero reverse-recovery of output diodes, an interleaved boost converter with coupled input inductors has lower current ripple and a smaller switching duty cycle than a normal boost [58]. A reverse coupling of this converter with lower inductor ripple current and negligible dc flux in the magnetic core can be found in [59]. Fig. 29(b) shows a schematic of a two-phase interleaved

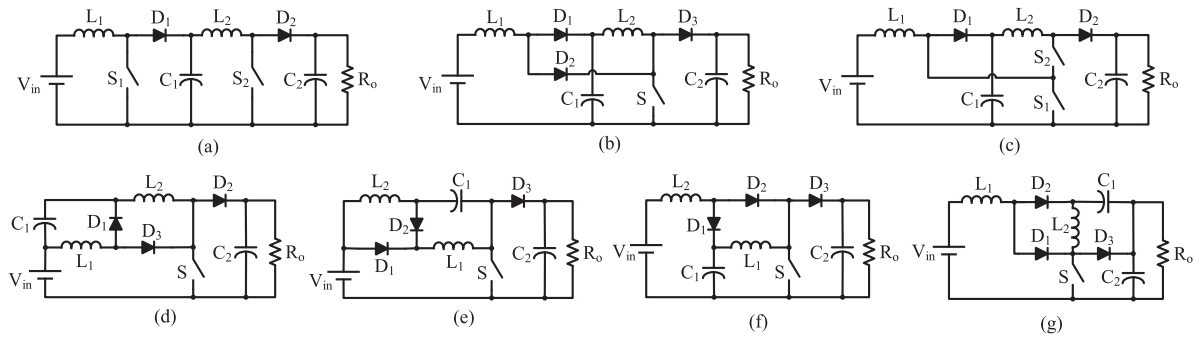

Fig. 27. Quadratic dc–dc converters. (a) Two cascaded boost converters. (b) Quadratic boost converter. (c) Three-level quadratic boost converter. (d)–(g) Some basic quadratic boost dc–dc converters.

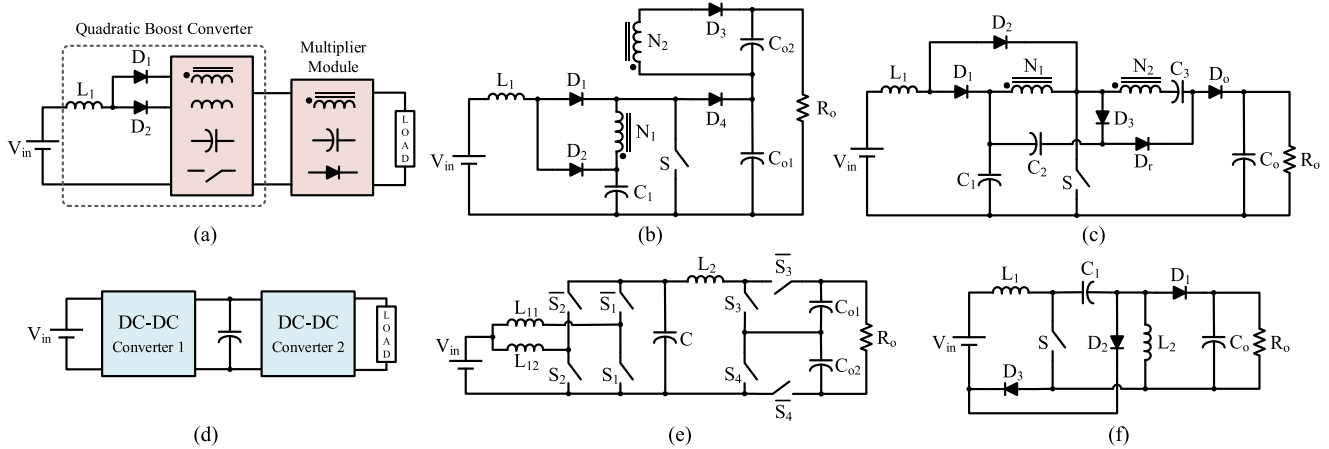

Fig. 28. Hybrid cascaded dc–dc converters. (a) General layout of the quadratic hybrid cascaded converter. (b) and (c) Some examples of quadratic-based hybrid cascaded converters. (d) General layout of the cascaded connection of two different converters. (e) and (f) Some examples of cascade connection of two different converters.

step-up dc–dc converter with passive/active clamp circuits and a voltage multiplier module (coupled inductor or transformer, SC) between the input switches and output diodes to increase the voltage step-up gain.

Various interleaved dc–dc converters can be connected in series with SC voltage multipliers [60], [61], [159]. Fig. 29(c) shows an SC cell that can be implemented in conjunction with an interleaved dc–dc converter with or without input inductor coupling. The voltage gain increases with the number of multiplier stages and is higher than in traditional boost converters [60], [159]. A CW multiplier module for an interleaved dc–dc converter is shown in Fig. 29(d). The voltage gain of this converter can be tuned with respect to the order of the voltage multiplier, and an active clamp circuit can be used in each interleaved stage to increase the efficiency [61]. An interleaved boost converter with a magnetic coupling multiplier circuit is shown in Fig. 29(e). This converter is a cascaded connection of an interleaved boost converter with a VMC at the output [62]. A common active clamped interleaved boost converter with coupled inductor, as illustrated in Fig. 29(f), was proposed in [63]. In this configuration, an extra boost converter is used to suppress the voltage stresses across the switches caused by leakage inductance. The leakage energy is collected in the clamp ca-

pacitor and powered to the load by the clamp boost converter. Fig. 29(g) shows a multiplier boost module with a passive lossless single snubber circuit for interleaved converters [64]. In the design, capacitor C_S acts as a turn-off snubber and is used to alleviate the switching loss. A limitation of using this snubber is that the duty cycle of the switch must not be greater than 0.5. One of the most important considerations in coupled-inductor-based boost cells used in interleaved topologies is the optimum design of the snubber circuit for recycling leakage energy.

Another type of coupled-inductor-based interleaved converter is shown in Fig. 29(h). Owing to the inherent voltage double function of the SCs and the proper turns ratio coupled inductor, high voltage gain can be achieved with this multiplier module [127]. The winding crossed coupled inductor (WCCI) concept was introduced to achieve high step-up and step-down in interleaved dc–dc converters [128]. Fig. 29(i) shows the basic structure of a WCCI configuration, in which two three-winding coupled inductors are used to step-up the voltage level. The first and second windings of each coupled inductor (N_{1a} and N_{1b}/N_{2a} and N_{2b}) are inserted to the same phase, and the third winding (N_{1c}/N_{2c}) is coupled to the inductors in another phase. Either an active or passive clamp can be used to recycle the leakage energy

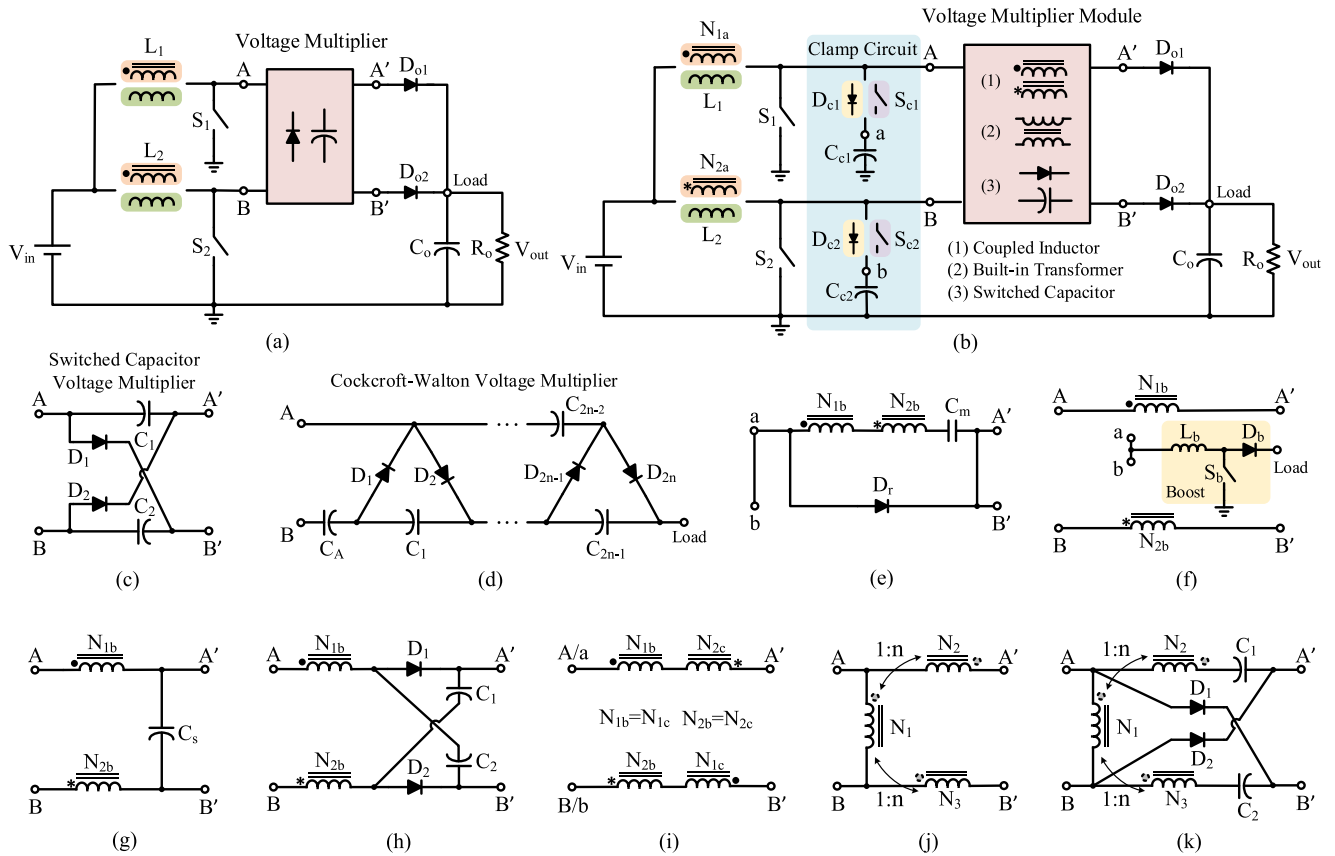

Fig. 29. Interleaved dc-dc converters. (a) and (b) General layouts of interleaved step-up converters. (c)–(k) Various multiplier modules for the interleaved step-up converter.

and absorb the voltage spike caused by the leakage inductance [128], [129]. As shown in Fig. 29(j), a three winding built-in transformer can be used instead of the WCCI to boost the voltage level [205]; as in the WCCI circuit, the leakage energy is recycled and voltage spikes are absorbed efficiently owing to the active clamp circuits on each phase. The boost ability can be further improved by using an SC voltage multiplier in this circuit [206], as shown in Fig. 29(k). Isolated interleaved dc-dc converters can also be found in the literature [261], [273]; these are based on the concept of parallel input and isolated series output. A comparison between various interleaved dc-dc converters with different boosting techniques is presented in Table IX.

3) *Multilevel*: Multilevel dc-dc converters are gaining attention in both industry and academia for their usefulness in high-power high-voltage applications. Multilevel converters in a dc-dc structure can help to decrease or almost eliminate magnetic components, which leads to reduced converter size and weight [17]–[19]. From the input voltage view, multilevel dc-dc converters can be divided into two major types: multilevel converters with a single dc or multiple dc sources. Single-source multilevel modular structures are of interest for use in electric vehicle (EV) or HEV and motor traction, as multiple distributed energy sources such as batteries, PVs, and FCs can be connected through a multilevel cascaded dc-dc converter to feed into a load or the ac grid without voltage balancing problems.

a) *Modular (single dc source)*: One topology for single-input multilevel structures is the boost converter with multiple submodules consisting of switches/diodes and capacitors [212]. A schematic of this converter with several submodules is shown in Fig. 30(a). The main advantages of this type of converter are its simplicity, modularity, and flexibility [47]. As can be inferred from Fig. 30(a), this type of multilevel converter comprises several submodules and is, therefore, called a multilevel modular dc-dc converter. Two basic structures of this kind without active switching at their output stages are shown in Fig. 30. In Fig. 30(b), a PWM boost converter is employed as the base level of a proposed multilevel converter [160]. In Fig. 30(c), a two-switch multilevel converter with no inductive element is shown [161]. The main advantage of these structures is their low-voltage stress on output devices.

Multilevel modular SC structures are another group of single-input multilevel dc-dc converters [65], [215]. The basic structure of this group is shown in Fig. 31(a). Converter modules in this category of multilevel converter usually consist of SC structures. In Fig. 31(b), a three-switch module with one capacitor is shown as a basic module for boosting the dc voltage level; this is also known as capacitor-clamped module for multilevel converters [131], [216]. In Fig. 31(c), another dc-dc module that uses two capacitors and four switches to double the dc input voltage is shown [217]. These converter types are addressed in more detail in Section III-A. In addition to the previously

TABLE IX
SUMMARY OF INTERLEAVED BOOST CONVERTERS

Interleaved Boost Converter	Voltage Gain* (V_{out}/V_{in})	Voltage Stress on the Switching Device	No.* of Semiconductors		No.* of Passive Components		Features
			Diode	Switch	Capacitor	Inductor	
Interleaved Boost with Coupled Inductor [58]	$\frac{1}{1-2D}$	$\frac{1-2D}{1-D}V_{out}$	2	2	1	2 coupled	<ul style="list-style-type: none"> • Low inductor ripple current. • Zero reverse-recovery of output diode. • Duty cycle is limited to 0.5 ($D<0.5$).
Interleaved Boost with Switched Capacitor Voltage Multiplier [60], [159]	$\frac{1}{D(1-D)}$ Coupled L	DV_{out}	4	2	3	2 coupled or 2 normal	<ul style="list-style-type: none"> • Simple boosting circuit. • Fast dynamic behavior. • No transformer for boosting. • Modularity of the structure allows increments of power levels and maintaining high efficiency.
	$\frac{2}{1-D}$ Normal L	$\frac{V_{out}}{2}$					
Interleaved Boost with Cockcroft-Walton Voltage Multiplier [61]	$\frac{N}{(1-D)}$ Where $N = 2n$	$\frac{V_{out}}{N}$	2n	2	2n	2 coupled	<ul style="list-style-type: none"> • High boost ability with high order multiplier. • Duty cycle is limited to 0.5 (hard switched) and with active clamped circuit duty cycle range is 0-1. • Soft switching (ZVS/ZCS) of semiconductors with $0.5<D<1n$.
Interleaved Boost with Voltage Multiplier Cell [62]	$\frac{2n+1}{1-D}$ Where $n = \frac{N_{1b}}{N_{1a}} = \frac{N_{2b}}{N_{2a}}$	$\frac{V_{out}}{2n+1}$	3	2	2	4 coupled, 2+2 separately	<ul style="list-style-type: none"> • Coupled inductor is used for high boost ability. • The reverse-recovery of output diode is alleviated. • ZCS turn-on of the switches.
Interleaved Boost Coupled Inductor with Common Active Clamp [63]	$\frac{1+nD}{1-D}$ Where $n = \frac{N_{1b}}{N_{1a}} = \frac{N_{2b}}{N_{2a}}$	$\frac{V_{out}}{1+nD}$	5	3	2	4 coupled, 2+2 separately, 1 normal	<ul style="list-style-type: none"> • Suitable for high voltage/current applications. • Active clamp circuit using auxiliary converter. • High efficiency in high step-up conversion.
Interleaved Boost Coupled Inductor with Single Capacitor Snubber [64]	$\frac{1+nD}{1-D}$ Where $n = \frac{N_{1b}}{N_{1a}} = \frac{N_{2b}}{N_{2a}}$	$\frac{V_{out}}{1+nD}$	2	2	2	4 coupled, 2+2 separately	<ul style="list-style-type: none"> • Lossless single capacitor turn-off snubber. • Duty cycle is limited to 0.5 ($D<0.5$). • High efficiency.
Interleaved Boost with Built-in Voltage Doubler [127]	$\frac{2+n(1+D)}{1-D}$ Where $n = \frac{N_{1b}}{N_{1a}} = \frac{N_{2b}}{N_{2a}}$	$\frac{V_{out}}{2+n(1+D)}$	4	2	3	4 coupled, 2+2 separately	<ul style="list-style-type: none"> • Built-in voltage doubler capacitors. • High boost ability. • ZVT operation of the switches.
Interleaved Boost with WCCI [129]	$\frac{1+n}{1-D}$ Where $n = \frac{N_{1b}}{N_{1a}} = \frac{N_{2b}}{N_{2a}}$	$\frac{V_{out}}{1+n}$	4/2	2/4	3	6 coupled, 3+3 separately	<ul style="list-style-type: none"> • Wide operation range. • The leakage energy absorbed effectively. • ZVT operation of the switches. • High efficiency.
Interleaved Boost with Built-in Transformer [205]	$\frac{1+n}{1-D}$ Where $n = \frac{N_2}{N_1} = \frac{N_3}{N_1}$	$\frac{V_{out}}{1+n}$	2	4	3	3 coupled	<ul style="list-style-type: none"> • High boost ability due to the built-in transformer. • ZVT operation of the switches. • Active clamp with voltage spike absorption. • Low reverse-recovery of output diodes.
Interleaved Boost with Built-in Transformer and Voltage Multiplier [206]	$\frac{2(1+n)}{1-D}$ Where $n = \frac{N_2}{N_1} = \frac{N_3}{N_1}$	$\frac{V_{out}}{2(1+n)}$	4	4	5	3 coupled	<ul style="list-style-type: none"> • Ultra step-up voltage gain due to the built-in transformer and voltage multiplier. • The switch and output diode voltage stresses are reduced.

* The leakage inductance is neglected in the equations.

* Number of all components of the converter from the referenced paper are taken into account.

mentioned multilevel structures, multilevel dc–dc converters with a diode clamp and flying capacitors can be classified under the single dc input source group and their principles are detailed in the literature [66], [67].

b) Cascaded (multiple dc source): To increase the output voltage level of PV or FC modules, such sources can be connected in series to increase their string voltage. This series-connected voltage can then be connected to a converter for regulation or further step-up purposes. On the other hand, such sources can be connected in cascaded multilevel connections, which have been claimed to have better reliability, safety/protection, and maintainability and lower cost [24], [38], [243]. This group of multilevel converter comprises cascaded

connections of multiple lower voltage dc–dc converters [see Fig. 32(a)] and is therefore called multilevel cascaded dc–dc converters. Fig. 32(b) shows a basic converter module for connecting an FC in a cascaded multilevel connection [39]. With this configuration, when S_H is ON and S_V is OFF, the corresponding FC module supplies the load, and if S_V is ON and S_H is OFF, the FC module does not supply power. In [40], a voltage-double-converter module for low-voltage modular sources was introduced. Fig. 32(c) shows a schematic of this converter, in which a small inductor can be introduced immediately following the input dc source to achieve the ZCS condition for all switches. Fig. 32(d) shows a conventional dc–dc boost converter as a single-converter module for integration within a cascaded

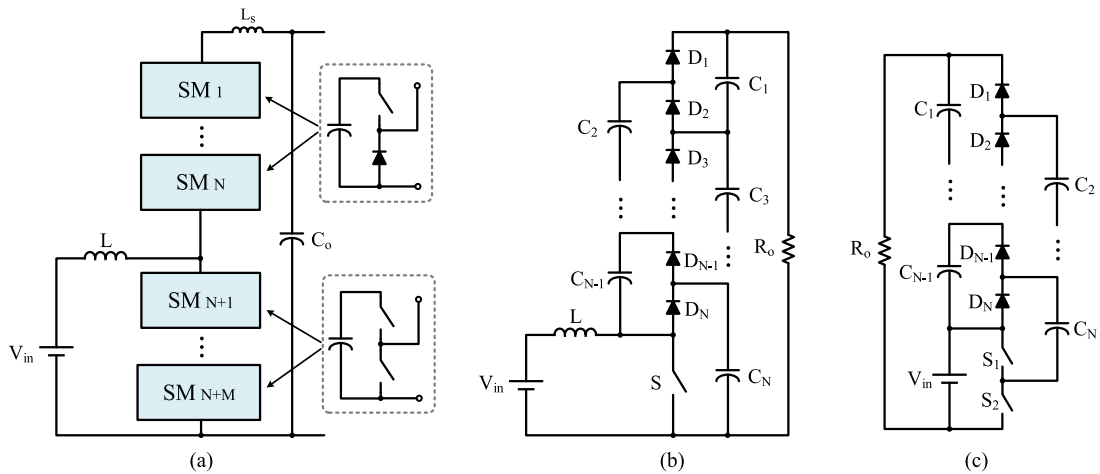

Fig. 30. Multilevel modular dc-dc converters with voltage multipliers. (a) General structure with several submodules. (b) and (c) Two examples for the multilevel dc-dc converter with voltage multiplier cells.

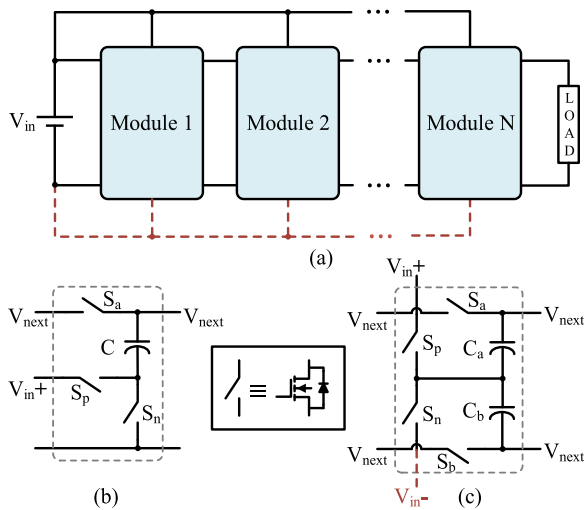

Fig. 31. Multilevel modular dc-dc converters with single dc source. (a) General structure. (b) and (c) Two example dc-dc modules.

multilevel converter [41]. In [24], other conventional dc-dc converter types such as buck-boost and Ćuk were proposed for this purpose. Fig. 32(e) shows a boost converter with two active switches [42]. When galvanic isolation is a concern, isolated dc-dc converter modules are utilized. Fig. 32(f) shows a fly-back half-bridge dc-dc converter module introduced for modular multilevel converters [236]. Other dc-dc converter modules with galvanic isolation, such as H-bridge and push-pull structures, can also be found in the literature [237].

As mentioned above, multilevel cascaded dc-dc converters process the entire generated power of individual input sources, which is an inefficient process for extracting maximum power when there is a mismatch in one of the input sources (e.g., partial shading in PV panels). Moreover, the charging process in a series of battery stacks can be equalized by processing charging power individually, which will increase the overall charging system efficiency [25]–[27], [238]. To cope with these issues in series sources/loads, partial power processing (or differential power processing) has been introduced [28] as a means for

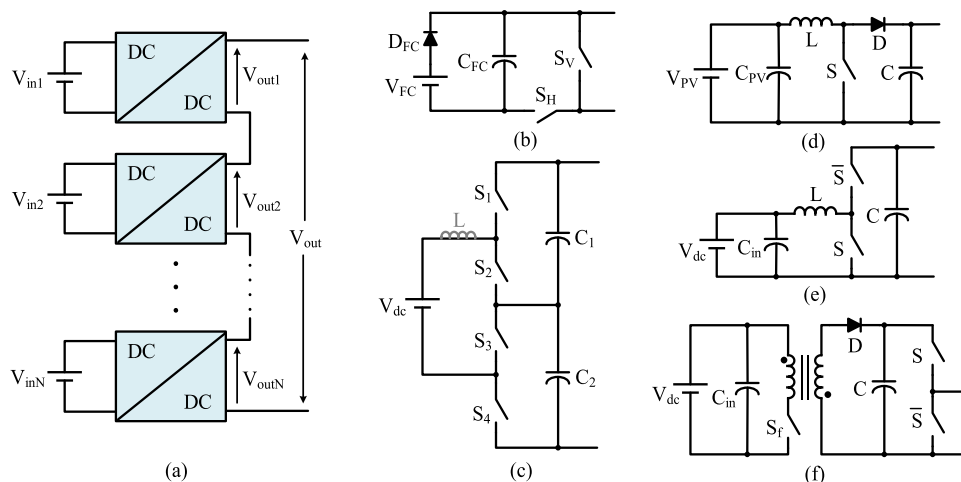

Fig. 32. Multilevel cascaded dc-dc converters with multiple dc sources. (a) General cascaded structure. (b)–(f) Various converter modules.

processing a fraction of each source more efficiently and only if necessary, e.g., by processing the difference maximum power current between two PV panels or diverting the current path of one charged battery pack to another.

IV. APPLICATIONS AND COMPARISON OF STEP-UP DC–DC CONVERTERS

Step-up dc–dc converters have been used for wide range of power conversion applications from the milliwatt scale upward, e.g., from energy harvesting to MW-level high-voltage dc transmission systems. The recent emphasis on energy efficiency and renewable energy development has intensified research on step-up converters in both academia and industry. Some applications driving this demand include energy harvesting, medical implantable devices, portable devices, gadgets, and appliances, lighting technology, space and avionics, transportation (automotive and railway) technology, telecommunications, data center, industrial, renewable energy, and DG in dc microgrids, high-voltage technology (physics research, medical, and military), high-voltage/power dc–dc converters, and high-voltage dc (HVDC) systems in utility grid applications [24], [38], [41], [42], [53], [114]–[122], [139], [178]–[188], [221]–[223], [228], [240]–[248], [263], [276], [281]–[309]. A broad overview of the scope of step-up dc–dc converters with different voltage and power levels used in various applications is illustrated in Fig. 33. The overall technological advancement in recent years is leading to increasing levels of power demand from a number of applications and systems. Correspondingly, it is important here not to limit or designate the specific power levels or input and output voltage levels for specific applications. Consequently, the voltage and power levels discussed here are used to approximately demonstrate the voltage and power requirements of dc–dc converters employed in relevant applications. Furthermore, in some applications that employ modular structures only the voltage and power levels of a single module are considered.

In ultralow-power applications, conventional boost dc–dc converters are being used to step-up the voltage level of micro-energy harvesting sources with low voltages and/or low currents [176], [177] using solar [178], microbial FC [179], thermoelectric [180], motion and vibration [181], and piezoelectric [116] energy. Usually, PWM boost dc–dc converters or other basic step-up dc–dc converters are employed in such applications owing to their simplicity, small size, and low weight. High step-up dc–dc converters are popular in portable electronic devices, in which battery storage systems or standalone renewable sources like PV and FC are typically employed as input sources to supply dc bus for electronic devices [117], [118]. With the emergence of wireless power transfer (WPT) technology, a prospective application area is developing for various low-power electronic gadget applications (i.e., cell phones, laptops, hand tools, etc.) [299], [300] and implantable medical devices [301], [302]. In such applications, dc–dc converters can construct an entire WPT system for supplying dc loads (e.g., battery, ultracapacitor, etc.) or can be employed separately to step-up the voltage at the receiver side in order to meet specific dc load requirements.

Lighting is another major sector that demands high-efficiency dc–dc converters as power supplies and driver circuits [53]. The development of light-emitting diodes (LED) has opened up a new era of lighting. As compared to conventional lighting systems, LED systems have longer life, smaller size, lower energy consumption, and improved robustness, all of which lead to improved lighting [244]. Step-up dc–dc converters are widely used in dimmable LED power supplies [182]. Stand-alone street lighting systems are another LED technology in which dc–dc conversion is used in battery storage systems [253]. Step-up dc–dc converters are used to increase the low voltage of car batteries (~ 12 V) to the high-voltage level required in automotive lighting systems that drive high-intensity discharge lamps and LED spotlights [119]. Display panels are another lighting-related technology in which step-up dc–dc converters are used as a power supply driver for plasma display panels [246] or as backlight power modules for liquid crystal displays (LCD) [183]. Older cold-cathode fluorescent lamp televisions are being replaced by LED models that achieve better backlighting contrast ratios. Although white LEDs are most prevalent, Red-Blue-Green LEDs can also be used to integrate the function of color contrast into LCD screens. Edge lit LED TVs use a few channels to drive strings of LEDs located on the perimeter of the television screen through waveguides that light strips along the back of the television [187]. This technology permits thin TV displays and lower costs but requires higher current LEDs. Similar technologies are used for desktop monitors, tablets, etc., that have typical boost specifications requiring a wide range of input voltage (4.5–20 V) and up to 42-V output to drive multiple channels of series-connected LEDs. Lower power LED lighting management units sometimes utilize CPs, particularly in cell phone camera flash LED drivers. Active matrix organic LED (AMOLED) panels have several advantages in terms of high quality, low power consumption, and low cost, making them suitable for mobile display applications, which require both positive and negative power supplies with different voltage levels [120].

SC converters have found widespread application in particular in the low- and high-power-density markets. As an example of such applications, CPs powered at less than ~ 5 W can be used in 3-D integration in order to fabricate CMOS silicon deep trench capacitors in the processes identical to those used for fabricating entire ICs [123], [134]. Single system-on-chip (SOC) solutions are quite useful for boosting low battery voltages such as 1.2 V alkaline or NiMH to microprocessor voltage levels (3.3–5 V) in portable electronic applications or high-side MOSFET gate drivers [303]. SOC power levels can often be limited by factors such as dielectric breakdown or narrow trenches when building capacitors in silicon; although high-power SC converters with large discrete capacitors have been reported and demonstrated, they have not yet seen widespread application [67].

In the automotive transportation sector, various dc–dc converter types have been used in the electrification systems of EVs, FC-EVs, and plug-in HEVs. Based on their power flow direction, these converters can be classified as unidirectional or bidirectional [213], [220], [284], [289], [294]. Unidirectional

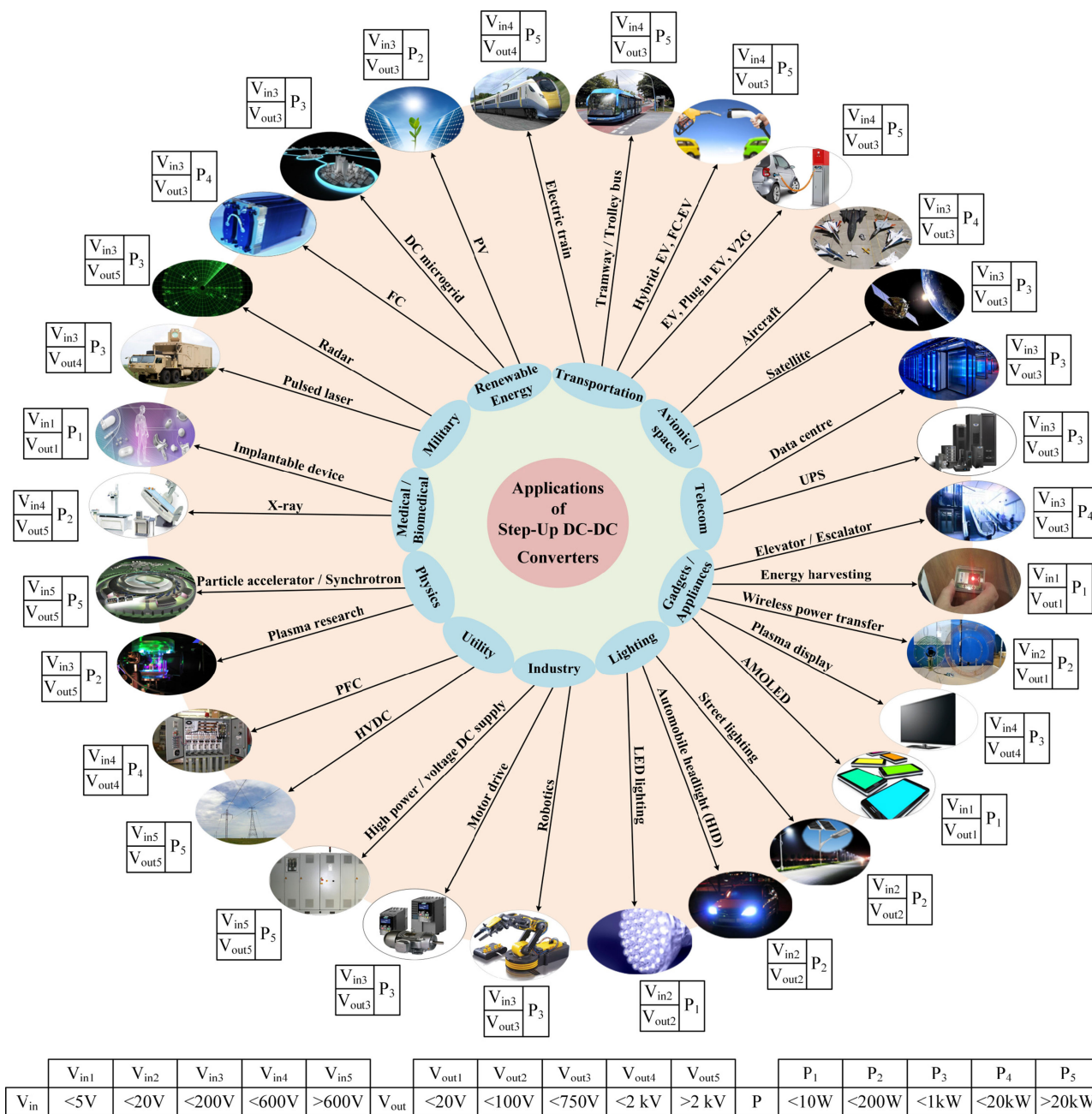

Fig. 33. Illustration of various applications of step-up dc–dc converters for milliwatt to megawatt levels.

dc–dc converters are also used in onboard applications such as sensors, controls, utility, entertainment, and safety equipment. Bidirectional dc–dc converters are required for battery charging in regenerative braking and for back-up power [298]. In the abovementioned applications, the voltage level of the battery storage system ($\sim 180\text{--}360\text{ V}$) is usually lower than in the loads ($\sim 400\text{--}750\text{ V}$), which led to the implementation of step-up dc–dc converters. Uninterruptable power supply (UPS) is another type of dc–dc converter application for use in integrated battery storage systems in which bidirectionally operating dc–dc conversion is desirable [291].

In high-power railway transportation systems, extracting the regenerative energy of a traction motor in the braking mode is a critical operation that requires the use of a bidirectional dc–dc converter [42]. Furthermore, trains with battery storage systems should employ bidirectional dc–dc converters in order to maintain their dc voltage within a specific range ($500\text{--}600\text{ V}$) in interconnected operating mode and supply the dc feeder voltage ($1\text{--}2\text{ kV}$) in isolated operating mode [221]. Similarly, the exploitation of regenerative energy from the electric motor of an elevator or escalator system in downward motion relies on the proper utilization of bidirectional dc–dc converters [214].

Examples of unidirectional dc–dc conversion in railway systems include an FC-battery hybrid tramway that utilizes a boost converter to regulate the dc traction bus voltage (~ 700 – 800 V) [222] and [223]. Furthermore, step-up dc–dc converters can provide proper dc output voltage, which is required by dc adjustable speed drives in trolleybus applications [184].

As fossil fuels become scarce, renewable energy sources such as PV, FC, and wind turbines not only help in decreasing greenhouse gas emissions but also provide much flexibility, reliability, and portability in power generation. Renewable and DG in microgrids is vital to sustaining high dc-bus voltages (380–400 V). Microgrids can operate in the grid-connected mode or islanding mode; in both cases, reliability and sustainability are major concerns [286], [292], and [297]. As the output voltage of renewable energy sources (PV, FC, and wind turbines) are usually low and variable, high step-up dc–dc converters are needed in their power conversion systems in order to meet dc line voltage requirements [122]. Furthermore, PV arrays are usually implemented with modular dc–dc structures in order to gain higher power levels, reliability, and efficiency [24], [38], and [41].

The increasing use of information and communication technology equipment is resulting in the introduction of different standards. In the last decade, 380-V dc distribution systems have begun to supplant conventional 48-V dc distribution systems. As a result, there is increasing demand for high step-up dc–dc converters in network server and data center applications [121], [139]. In avionic standards, 28-V dc load bus and 270-V high-voltage dc bus are the most common voltage requirements for aircraft electrification [304]. Typically, bidirectional dc–dc converters are employed in the battery back-up systems of aircraft in order to convert low-voltage inputs to a high-voltage dc bus in the boost mode [281], [288], [293], [304]. In such systems, the battery storage can be used at the 28-V dc bus, the bidirectional converter should supply the 270-V dc bus, and the motor controllers can use even higher levels, i.e., 540-V dc. In space applications, by contrast, high-voltage dc–dc converters with modular structure are usually employed to obtain the kilovolt voltage levels (based on individual modules under 1-kV apiece) required for space shuttle/satellite applications [239], [276].

Higher output voltage dc–dc converters are being used widely in many applications including medical, military, and physics experimentation [247], [305]. In X-ray power generators and high-voltage CO₂ laser applications, SC voltage multipliers (i.e., CW multiplier) are typically used to achieve high-voltage levels in X-ray/laser discharge tubes [240], [248]. In pulsed power applications such as pulsed lasers and radar systems, in which high-voltage pulses are required, the use of a capacitor charging power supply (CCPS) is a potential solution. In this application, a high-voltage dc–dc converter is used to charge a capacitive load (at kilovolt levels) [241], [263]. Plasma research is yet another technology that requires high-voltage dc power supplies to charge large capacitive loads to specific high-voltage levels [282].

Robotics and motor drive technologies have become part of the main stream in the production lines of various industries. Step-up dc–dc converters are being employed in fac-

tory production lines to control dc motor speed or supply the voltage requirements of dc buses [245] and [306]. In recent decades, advancements in high-power electronics technology has resulted in the use of high-power dc–dc converters with kilowatt levels in a broad range of applications including renewable energy, military, and industrial applications [185], [228].

From the inception of ac power systems, power factor correction requirements have always led to the use of dc–dc boost converters [186]. Prior to the advent of ac transmission, power lines used exclusively dc transmission, but increasing losses at the voltage levels available more than 100 years ago meant that dc was not amenable to long distance transmission. Voltage-source converter high-voltage dc (VSC-HVDC) is an electric power transmission technology based on the use of high-power dc–dc converters and modern HVDC cables that can be implemented in long or short transmission lines. VSC-HVDC technology is being considered as a practical solution for the integration of renewable energy sources for which designers must overcome high step-up dc voltage ratios at high (megawatt size) power levels [188]. Voltage-source HVDC technology was first introduced by ABB as HVDC Light; later on, similar concepts based on MMCs called HVDC PULS and HVDC MaxSine were developed by Siemens and Alstom, respectively [307]. The power range in the voltage source in HVDC technology is just a few tens of megawatt, which is more economical and feasible than traditional line-commutated HVDC transmission. The appropriate connection of HVDC transmission using high-voltage dc–dc converters is an important issue; in these systems, MMCs have become popular owing to their significant reduction of harmonic content and their scalability in terms of voltage levels [308], [309].

V. SUMMARY AND CONCLUSION

The ongoing technological progress in high-voltage step-up dc–dc converter has five primary drivers—energy efficiency, power density, cost, complexity, and reliability—all of which also influence each other to some extent. Table X, along with the spider wave diagram in Fig. 34, provides a comparative summary of various voltage-boosting techniques in terms of their major characteristics (i.e., power level, cost, reliability, efficiency, power density, weight, integration, and complexity). This view facilitates quick selection between related alternatives for special load and application requirements. Each voltage-boosting technique has its own unique features and suitable applications, and there is no one-size-fits-all solution. Nevertheless, it is generally not fair to permanently favor any particular technique or solution. The converter topology and control method, which was seen as complex and inefficient a decade back, has now become a key solution for many industries and applications. In this manner, new topologies based on different and often merged voltage-boosting techniques will continue to appear in order to meet and improve the performance of different applications. Thanks to the progress in power-semiconductor devices, new widebandgap devices (GaN, SiC, etc.), advanced magnetic materials, high-performance digital control platforms,

TABLE X
SUMMARY OF BOOSTING TECHNIQUES ON DC–DC CONVERTERS AND THEIR APPLICATIONS

Voltage Boosting Technique	Advantages	Disadvantages	Appropriate Applications
Switched Capacitor (Charge Pump)	<ul style="list-style-type: none"> • Cheap and lightweight circuits. • Small size, and high power density. • Easy to be integrated. • Fast dynamic response. 	<ul style="list-style-type: none"> • Inrush current at start-up. • Sensitive to the ESR of capacitors. • Lack of output voltage regulation. • Only discrete output voltage. 	<ul style="list-style-type: none"> • Energy Harvesting. • Mobile displays (AMOLED). • Automotive and vehicular applications. • High gain dc–dc applications.
Voltage Multiplier	<ul style="list-style-type: none"> • Very high voltage ability with simple topology. • Cell based structure. • Can be integrated to various structures. 	<ul style="list-style-type: none"> • High voltage stress on components. • Need several cells with high ratings for very high voltage applications. 	<ul style="list-style-type: none"> • Medical (X-ray, laser). • Military (high power laser). • Physics (plasma research, particle accelerator).
Switched Inductor and Voltage Lift	<ul style="list-style-type: none"> • High boost ability. • Amenable in many converters. 	<ul style="list-style-type: none"> • Need more passive components. • Not suitable for high power applications. 	<ul style="list-style-type: none"> • Mid-range dc–dc converters. • High gain dc–dc applications.
Magnetic Coupling	<ul style="list-style-type: none"> • High design freedom. • Versatile in boost ability due to tunable turns ratio of magnetic coupling. • Switch can be implemented in low voltage side help to reduce conduction loss. • High efficiency in soft switched type. 	<ul style="list-style-type: none"> • Negative effects of leakage inductance such as large voltage spike. • Need precise coupled magnetic design. • Relatively bulky. 	<ul style="list-style-type: none"> • High power/voltage DC supply. • High voltage applications (military, physics). • CCPS for capacitive pulsed loads. • DC microgrids. • Telecommunication and data centers. • Bidirectional (FC, PV, UPS, P-EV, H-EV, V2G). • Regenerative (elevator, tram/trolleybus). • Avionic and space.
Multi-Stage/-Level	<ul style="list-style-type: none"> • Modularity structure. • High power capability. • Reliable and efficient. • High voltage/current level. 	<ul style="list-style-type: none"> • Large amount of components. • Relatively heavy, bulky and costly. • Efficiency deteriorate with number of stages/-levels. 	<ul style="list-style-type: none"> • HVDC transmission. • Renewable energy systems and distributed power generation (e.g., PV, FC). • DC microgrids. • High power DC supply. • EV, HEV and FC-EV • Space technology and applications

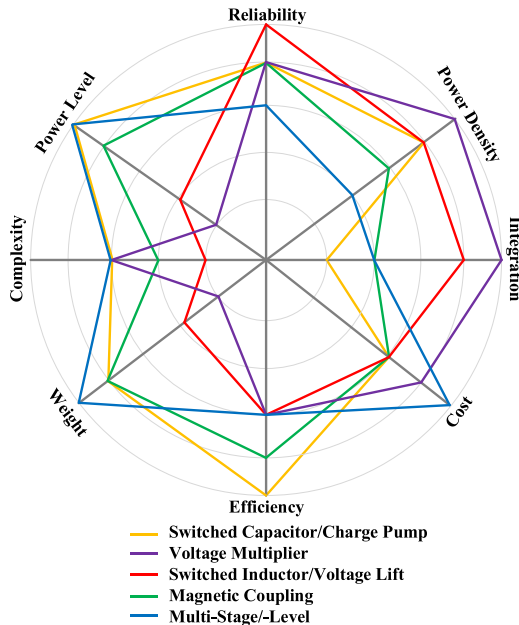

Fig. 34. Comparative analysis of different voltage-boosting techniques.

and advanced design and packaging including thermal management (3-D integrated) have all become a reality. These advances will undeniably enable more powerful and advanced power converter solutions for the next generation of power conversion systems. Overall, the authors hope that this comprehensive survey will be a useful resource to help both academic and industry readers comprehend step-up dc–dc converter topologies and identify their respective pros and cons.

REFERENCES

- [1] T. G. Wilson, “The evolution of power electronics,” *IEEE Trans. Power Electron.*, vol. 15, no. 3, pp. 439–446, May 2000.
- [2] B. K. Bose, “The past, present, and future of power electronics,” *IEEE Ind. Electron. Mag.*, vol. 3, no. 2, pp. 7–11, Jun. 2009.
- [3] M. H. Rashid, *Power Electronics Handbook: Devices Circuits and Application*, 3rd ed. Burlington, MA, USA: Elsevier, 2011.
- [4] M. K. Kazimierczuk, *Pulse-Width Modulated DC-DC Power Converters*. Chichester, U.K.: Wiley, 2008.
- [5] R. W. Erickson and D. Maksimovic, *Fundamentals of Power Electronics*, 2nd ed. Norwell, MA, USA: Kluwer, 2001.
- [6] M. M. Jovanovic, “A technique for reducing rectifier reverse-recovery-related losses in high-power boost converters,” *IEEE Trans. Power Electron.*, vol. 13, no. 5, pp. 932–941, Sep. 1998.
- [7] H. Chung, S. Y. R. Hui, and K. K. Tse, “Reduction of power converter EMI emission using soft-switching technique,” *IEEE Trans. Electromagn. Compat.*, vol. 40, no. 3, pp. 282–287, Aug. 1998.
- [8] B. W. Williams, “DC-to-DC converters with continuous input and output power,” *IEEE Trans. Power Electron.*, vol. 28, no. 5, pp. 2307–2316, May 2013.
- [9] R. W. Erickson, “DC-DC power converters,” in *Wiley Encyclopedia of Electrical and Electronics Engineering*. Hoboken, NJ, USA: Wiley, 1999.
- [10] R. D. Middlebrook, “Transformerless DC-to-DC converters with large conversion ratios,” *IEEE Trans. Power Electron.*, vol. 3, no. 4, pp. 484–488, Oct. 1988.
- [11] F. L. Tofoli, D. de Castro Pereira, W. J. de Paula, and D. de Sousa Oliveira Júnior, “Survey on non-isolated high-voltage step-up DC-DC topologies based on the boost converter,” *IET Power Electron.*, vol. 8, no. 10, pp. 2044–2057, 2015.
- [12] Y. Gu, W. Li, Y. Zhao, B. Yang, C. Li, and X. He, “Transformerless inverter with virtual dc bus concept for cost-effective grid-connected PV power systems,” *IEEE Trans. Power Electron.*, vol. 28, no. 2, pp. 793–805, Feb. 2013.
- [13] M. T. Zhang, Y. Jiang, F. C. Lee, and M. M. Jovanovic, “Single-phase three-level boost power factor correction converter,” in *Proc. 10th Annu. Appl. Power Electron. Conf. Expo.*, 1995, pp. 434–439.
- [14] H. R. Karshenas, A. Bakhshai, A. Safaee, H. Daneshpajoo, and P. Jain, *Bidirectional DC-DC Converters for Energy Storage Systems*. Rijeka, Croatia: InTech, May 2011, pp. 161–178.

- [15] M. K. Kazimierczuk, D. Q. Vuong, B. T. Nguyen, and J. A. Weimer, "Topologies of bidirectional PWM DC-DC power converters," in *Proc. IEEE Nat. Aerosp. Electron. Conf.*, 1993, pp. 435–441.
- [16] D. Zhou, "Synthesis of PWM DC-to-DC power converters," Ph.D. dissertation, California Inst. Technol., Pasadena, CA, USA, 1996.
- [17] F. Zhang, F. Z. Peng, and Z. Qian, "Study of the multilevel converters in DC-DC applications," in *Proc. IEEE 35th Annu. Power Electron. Spec. Conf.*, 2004, pp. 1702–1706.
- [18] S. Kouro *et al.*, "Recent advances and industrial applications of multilevel converters," *IEEE Trans. Ind. Electron.*, vol. 57, no. 8, pp. 2553–2580, Aug. 2010.
- [19] F. Z. Peng, W. Qian, and D. Cao, "Recent advances in multilevel converter/inverter topologies and applications," in *Proc. Int. Power Electron. Conf.*, 2010, pp. 492–501.
- [20] Y. P. Siwakoti, F. Z. Peng, F. Blaabjerg, P. C. Loh, and G. E. Town, "Impedance-source networks for electric power conversion—Part I: A topological review," *IEEE Trans. Power Electron.*, vol. 30, no. 2, pp. 699–716, Feb. 2015.
- [21] O. Krykunov, "Comparison of the dc/dc-converters for fuel cell applications," *Int. J. Elect., Comput., Syst. Eng.*, vol. 1, no. 1, pp. 71–79, 2007.
- [22] J. C. Doyle, B. A. Francis, and A. R. Tannenbaum, *Feedback Control Theory*. New York, NY, USA: Macmillan, 1990.
- [23] S. Skogestad and I. Postlethwaite, *Multivariable Feedback Control: Analysis and Design*, vol. 2. New York, NY, USA: Wiley, 2007.
- [24] G. R. Walker and P. C. Sernia, "Cascaded DC-DC converter connection of photovoltaic modules," *IEEE Trans. Power Electron.*, vol. 19, no. 4, pp. 1130–1139, Jul. 2004.
- [25] S. Poshtkouhi, A. Biswas and O. Trescases, "DC-DC converter for high granularity, sub-string MPPT in photovoltaic applications using a virtual-parallel connection," in *Proc. IEEE 27th Annu. Appl. Power Electron. Conf. Expo.*, 2012, pp. 86–92.
- [26] J. T. Stauth, M. D. Seeman, and K. Kesarwani, "Resonant switched-capacitor converters for sub-module distributed photovoltaic power management," *IEEE Trans. Power Electron.*, vol. 28, no. 3, pp. 1189–1198, Mar. 2013.
- [27] P. S. Shenoy, K. A. Kim, B. B. Johnson, and P. T. Krein, "Differential power processing for increased energy production and reliability of photovoltaic systems," *IEEE Trans. Power Electron.*, vol. 28, no. 6, pp. 2968–2979, Jun. 2013.
- [28] P. S. Shenoy and P. T. Krein, "Differential power processing for DC systems," *IEEE Trans. Power Electron.*, vol. 28, no. 4, pp. 1795–1806, Apr. 2013.
- [29] J. D. Cockcroft and E. T. S. Walton, "Experiments with high velocity positive ions. (I) Further developments in the method of obtaining high velocity positive ions," *Proc. Roy. Soc. A*, vol. 136, no. 830, pp. 619–630, Jun. 1932.
- [30] "The Nobel Prize in Physics 1951." *Nobel prize.org. Nobel Media AB 2014. Web. Sep. 24, 2016.* [Online]. Available: http://www.nobelprize.org/nobel_prizes/physics/laureates/1951/
- [31] Y. P. Siwakoti, F. Blaabjerg, and P. C. Loh, "New magnetically coupled impedance (Z -) source networks," *IEEE Trans. Power Electron.*, vol. 31, no. 11, pp. 7419–7435, Nov. 2016.
- [32] C. M. C. Duarte, and I. Barbi, "A family of ZVS-PWM active-clamping DC-to-DC converters: Synthesis, analysis, design, and experimentation," *IEEE Trans. Circuits Syst. I, Fundam. Theory Appl.*, vol. 44, no. 8, pp. 698–704, Aug. 1997.
- [33] H. S. Choi and B. H. Cho, "Novel zero-current-switching (ZCS) PWM switch cell minimizing additional conduction loss," *IEEE Trans. Ind. Electron.*, vol. 49, no. 1, pp. 165–172, Feb. 2002.
- [34] C. M. Wang, "Novel zero-voltage-transition PWM DC-DC converters," *IEEE Trans. Ind. Electron.*, vol. 53, no. 1, pp. 254–262, Feb. 2006.
- [35] D. Y. Lee, M. K. Lee, D. S. Hyun, and I. Choy, "New zero-current-transition PWM DC/DC converters without current stress," *IEEE Trans. Power Electron.*, vol. 18, no. 1, pp. 95–104, Jan. 2003.
- [36] A. Elasser and D. A. Torrey, "Soft switching active snubbers for DC/DC converters," *IEEE Trans. Power Electron.*, vol. 11, no. 5, pp. 710–722, Sep. 1996.
- [37] J. Y. Zhu and D. Ding, "Zero-voltage-and zero-current-switched PWM DC-DC converters using active snubber," *IEEE Trans. Ind. Appl.*, vol. 35, no. 6, pp. 1406–1412, Nov./Dec. 1999.
- [38] A. I. Bratcu, I. Munteanu, S. Bacha, D. Picault, and B. Raison, "Cascaded DC-DC converter photovoltaic systems: Power optimization issues," *IEEE Trans. Ind. Electron.*, vol. 58, no. 2, pp. 403–411, Feb. 2011.
- [39] B. Ozpineci, L. M. Tolbert, G. J. Su, and Z. Du, "Optimum fuel cell utilization with multilevel DC-DC converters," in *Proc. IEEE Annu. Appl. Power Electron. Conf. Expo.*, 2004, vol. 3, pp. 1572–1576.
- [40] M. Shen, F. Z. Peng, and L. M. Tolbert, "Multilevel DC-DC power conversion system with multiple DC sources," *IEEE Trans. Power Electron.*, vol. 23, no. 1, pp. 420–426, Jan. 2008.
- [41] S. Vighetti, J. P. Ferrieux, and Y. Lembeze, "Optimization and design of a cascaded DC/DC converter devoted to grid-connected photovoltaic systems," *IEEE Trans. Power Electron.*, vol. 27, no. 4, pp. 2018–2027, Apr. 2012.
- [42] D. Montesinos-Miracle, M. Massot-Campos, J. Bergas-Jane, S. Galceran-Arellano, and A. Rufer, "Design and control of a modular multilevel DC/DC converter for regenerative applications," *IEEE Trans. Power Electron.*, vol. 28, no. 8, pp. 3970–3979, Aug. 2013.
- [43] H. Matsuo and K. Harada, "The cascade connection of switching regulators," *IEEE Trans. Ind. Appl.*, vol. IA-12, no. 2, pp. 192–198, Mar. 1976.
- [44] T. S. Wu and T. H. Yu, "Unified approach to developing single-stage power converters," *IEEE Trans. Aerosp. Electron. Syst.*, vol. 34, no. 1, pp. 211–223, Jan. 1998.
- [45] I. C. Kobougias and E. C. Tatakis, "Optimal design of a half-wave Cockcroft-Walton voltage multiplier with minimum total capacitance," *IEEE Trans. Power Electron.*, vol. 25, no. 9, pp. 2460–2468, Sep. 2010.
- [46] B. W. Williams, "Unified synthesis of tapped-inductor DC-to-DC converters," *IEEE Trans. Power Electron.*, vol. 29, no. 10, pp. 5370–5383, Oct. 2014.
- [47] J. C. Rosas-Caro, J. C. Mayo-Maldonado, R. Salas-Cabrera, A. Gonzalez-Rodriguez, E. N. Salas-Cabrera, and R. Castillo-Ibarra, "A family of DC-DC multiplier converters," *Eng. Lett.*, vol. 19, pp. 57–67, 2011.
- [48] R. Guo, Z. Liang, and A. Q. Huang, "A family of Multimodes charge pump based DC-DC converter with high efficiency over wide input and output range," *IEEE Trans. Power Electron.*, vol. 27, no. 11, pp. 4788–4798, Nov. 2012.
- [49] M. Prudente, L. L. Pfitscher, G. Emmendoerfer, E. F. Romaneli, and R. Gules, "Voltage multiplier cells applied to non-isolated DC-DC converters," *IEEE Trans. Power Electron.*, vol. 23, no. 2, pp. 871–887, Mar. 2008.
- [50] E. H. Ismail, M. A. Al-Saffar, A. J. Sabzali, and A. A. Fardoun, "A family of single-switch PWM converters with high step-up conversion ratio," *IEEE Trans. Circuits Syst. I, Reg. Papers*, vol. 55, no. 4, pp. 1159–1171, May 2008.
- [51] B. Axelrod, Y. Berkovich, and A. Ioinovici, "Switched-capacitor/switched-inductor structures for getting transformerless hybrid DC-DC PWM converters," *IEEE Trans. Circuits Syst. I, Reg. Papers*, vol. 55, no. 2, pp. 687–696, Mar. 2008.
- [52] E. H. Ismail, M. A. Al-Saffar, A. J. Sabzali, and A. A. Fardoun, "High voltage gain single-switch non-isolated DC-DC converters for renewable energy applications," in *Proc. IEEE Int. Conf. Sustain. Energy Technol.*, 2010, pp. 1–6.
- [53] A. Pollock, H. Pollock, and C. Pollock, "High efficiency LED power supply," *IEEE J. Emerg. Sel. Topics Power Electron.*, vol. 3, no. 3, pp. 617–623, Sep. 2015.
- [54] G. Palumbo and D. Pappalardo, "Charge pump circuits: An overview on design strategies and topologies," *IEEE Circuits Syst. Mag.*, vol. 10, no. 1, pp. 31–45, First Quarter 2010.
- [55] M. S. Makowski and D. Maksimovic, "Performance limits of switched-capacitor DC-DC converters," in *Proc. IEEE 26th Annu. Power Electron. Spec. Conf.*, 1995, pp. 1215–1221.
- [56] F. L. Luo, "Switched-capacitorized DC/DC converters," in *Proc. IEEE 6th Int. Power Electron. Motion Control Conf.*, 2009, pp. 1074–1079.
- [57] M. D. Seeman, "A design methodology for switched-capacitor DC-DC converters," Univ. California, Berkeley, Berkeley, CA, USA, Tech. Rep. UCB/EERC-2009-78, May 2009.
- [58] P. W. Lee, Y. S. Lee, D. K. W. Cheng, and X. C. Liu, "Steady-state analysis of an interleaved boost converter with coupled inductors," *IEEE Trans. Ind. Electron.*, vol. 47, no. 4, pp. 787–795, Aug. 2000.
- [59] H. Kosai, S. McNeal, B. Jordan, J. Scofield, B. Ray, and Z. Turgut, "Coupled inductor characterization for a high performance interleaved boost converter," *IEEE Trans. Magn.*, vol. 45, no. 10, pp. 4812–4815, Oct. 2009.
- [60] R. Giral, L. Martinez-Salamero, R. Leyva, and J. Maixe, "Sliding-mode control of interleaved boost converters," *IEEE Trans. Circuits Syst. I, Fundam. Theory Appl.*, vol. 47, no. 9, pp. 1330–1339, 2000.
- [61] P. Kim, S. Lee, J. Park, and S. Choi, "High step-up interleaved boost converters using voltage multiplier cells," in *Proc. 8th Int. Conf. Power Electron.*, 2011, pp. 2844–2851.

- [62] W. Li, Y. Zhao, Y. Deng, and X. He, "Interleaved converter with voltage multiplier cell for high step-up and high-efficiency conversion," *IEEE Trans. Power Electron.*, vol. 25, no. 9, pp. 2397–2408, Sep. 2010.
- [63] S. Dwari and L. Parsa, "An efficient high-step-up interleaved DC-DC converter with a common active clamp," *IEEE Trans. Power Electron.*, vol. 26, no. 1, pp. 66–78, Jan. 2011.
- [64] S. Y. Tseng and C. Y. Hsu, "Interleaved step-up converter with a single-capacitor snubber for PV energy conversion applications," *Int. J. Electr. Power Energy Syst.*, vol. 53, pp. 909–922, 2013.
- [65] J. C. Rosas-Caro, J. M. Ramirez, and P. M. G. Vite, "A novel two switches based DC-DC multilevel voltage multiplier," in *Proc. Int. Symp. Power Electron., Elect. Drives, Autom. Motion*, 2008, pp. 930–934.
- [66] W. Qian, D. Cao, J. G. Cintron-Rivera, M. Gebben, D. Wey, and F. Z. Peng, "A switched-capacitor DC-DC converter with high voltage gain and reduced component rating and count," *IEEE Trans. Ind. Appl.*, vol. 48, no. 4, pp. 1397–1406, Jul./Aug. 2012.
- [67] K. Kesarwani and J. T. Stauth, "Resonant and multi-mode operation of flying capacitor multi-level DC-DC converters," in *Proc. IEEE 16th Workshop Control Model. Power Electron.*, 2015, pp. 1–8.
- [68] J. A. Starzyk, J. Ying-Wei, and F. Qiu, "A DC-DC charge pump design based on voltage doublers," *IEEE Trans. Circuits Syst. I, Fundam. Theory Appl.*, vol. 48, no. 3, pp. 350–359, Mar. 2001.
- [69] M. D. Seeman and S. R. Sanders, "Analysis and optimization of switched-capacitor DC-DC converters," *IEEE Trans. Power Electron.*, vol. 23, no. 2, pp. 841–851, Mar. 2008.
- [70] M. S. Makowski, "Realizability conditions and bounds on synthesis of switched-capacitor DC-DC voltage multiplier circuits," *IEEE Trans. Circuits Syst. I, Fundam. Theory Appl.*, vol. 44, no. 8, pp. 684–691, Aug. 1997.
- [71] H. S. H. Chung, "Design and analysis of a switched-capacitor-based step-up DC/DC converter with continuous input current," *IEEE Trans. Circuits Syst. I, Fundam. Theory Appl.*, vol. 46, no. 6, pp. 722–730, Jun. 1999.
- [72] B. Wu, S. Li, K. M. Smedley, and S. Singer, "A family of two-switch boosting switched-capacitor converters," *IEEE Trans. Power Electron.*, vol. 30, no. 10, pp. 5413–5424, Oct. 2015.
- [73] A. A. Fardoun and E. H. Ismail, "Ultra step-up DC-DC converter with reduced switch stress," *IEEE Trans. Ind. Appl.*, vol. 46, no. 6, pp. 2025–2034, Sep./Oct. 2010.
- [74] L. H. S. C. Barreto, P. P. Praca, G. A. L. Henn, R. N. A. L. Silva, and D. S. Oliveira, "Single stage high voltage gain boost converter with voltage multiplier cells for battery charging using photovoltaic panels," in *Proc. 27th IEEE Annu. Appl. Power Electron. Conf. Expo.*, 2012, pp. 364–368.
- [75] K. I. Hwu and Y. T. Yau, "High step-up converter based on charge pump and boost converter," *IEEE Trans. Power Electron.*, vol. 27, no. 5, pp. 2484–2494, May 2012.
- [76] T. Nouri, S. H. Hosseini, E. Babaei, and J. Ebrahimi, "Generalised transformerless ultra step-up DC-DC converter with reduced voltage stress on semiconductors," *IET Power Electron.*, vol. 7, no. 11, pp. 2791–2805, 2014.
- [77] X. Hu and C. Gong, "A high gain input-parallel output-series DC/DC converter with dual coupled inductors," *IEEE Trans. Power Electron.*, vol. 30, no. 3, pp. 1306–1317, Mar. 2015.
- [78] J. W. Baek, M. H. Ryoo, T. J. Kim, D. W. Yoo, and J. S. Kim, "High boost converter using voltage multiplier," in *Proc. 31st Annu. Conf. IEEE Ind. Electron. Soc.*, 2005, pp. 567–572.
- [79] T. J. Liang, S. M. Chen, L. S. Yang, J. F. Chen, and A. Ioinovici, "Ultra-large gain step-up switched-capacitor DC-DC converter with coupled inductor for alternative sources of energy," *IEEE Trans. Circuits Syst. I, Reg. Papers*, vol. 59, no. 4, pp. 864–874, Apr. 2012.
- [80] Y. P. Hsieh, J. F. Chen, T. J. Liang, and L. S. Yang, "Novel high step-up DC-DC converter with coupled-inductor and switched-capacitor techniques for a sustainable energy system," *IEEE Trans. Power Electron.*, vol. 26, no. 12, pp. 3481–3490, Dec. 2011.
- [81] F. L. Luo, "Luo-converters, voltage lift technique," in *Proc. 29th Annu. IEEE Power Electron. Spec. Conf.*, 1998, vol. 2, pp. 1783–1789.
- [82] F. L. Luo, "Luo-converters, a series of new DC-DC step-up (boost) conversion circuits," in *Proc. 2nd Int. Conf. Power Electron. Drive Syst.*, 1997, vol. 2, pp. 882–888.
- [83] F. L. Luo, "Six self-lift DC-DC converters, voltage lift technique," *IEEE Trans. Ind. Electron.*, vol. 48, no. 6, pp. 1268–1272, Dec. 2001.
- [84] F. L. Luo, "Analysis of super-lift Luo-converters with capacitor voltage drop," in *Proc. 3rd IEEE Conf. Ind. Electron. Appl.*, 2008, pp. 417–422.
- [85] Y. Jiao, F. L. Luo, and M. Zhu, "Voltage-lift-type switched-inductor cells for enhancing DC-DC boost ability: principles and integrations in Luo converter," *IET Power Electron.*, vol. 4, no. 1, pp. 131–142, 2011.
- [86] Y. Tang, T. Wang, and D. Fu, "Multicell switched-inductor/switched-capacitor combined active-network converters," *IEEE Trans. Power Electron.*, vol. 30, no. 4, pp. 2063–2072, Apr. 2015.
- [87] Y. Ye and K. W. E. Cheng, "A family of single-stage switched-capacitor-inductor PWM converters," *IEEE Trans. Power Electron.*, vol. 28, no. 11, pp. 5196–5205, Nov. 2013.
- [88] K. W. E. Cheng and Y. M. Ye, "Duality approach to the study of switched-inductor power converters and its higher-order variations," *IET Power Electron.*, vol. 8, no. 4, pp. 489–496, 2015.
- [89] Y. Jiao, F. L. Luo, and M. Zhu, "Generalised modelling and sliding mode control for n-cell cascade super-lift DC-DC converters," *IET Power Electron.*, vol. 4, no. 5, pp. 532–540, 2011.
- [90] F. L. Luo and H. Ye, "Positive output super-lift converters," *IEEE Trans. Power Electron.*, vol. 18, no. 1, pp. 105–113, Jan. 2003.
- [91] L. S. Yang, T. J. Liang, and J. F. Chen, "Transformerless DC-DC converters with high step-up voltage gain," *IEEE Trans. Ind. Electron.*, vol. 56, no. 8, pp. 3144–3152, Aug. 2009.
- [92] Y. Tang, D. Fu, T. Wang, and Z. Xu, "Hybrid switched-inductor converters for high step-up conversion," *IEEE Trans. Ind. Electron.*, vol. 62, no. 3, pp. 1480–1490, Mar. 2015.
- [93] Y. Tang, D. Fu, T. Wang, and Z. Xu, "Analysis of active-network converter with coupled inductors," *IEEE Trans. Power Electron.*, vol. 30, no. 9, pp. 4874–4882, Sep. 2015.
- [94] H. Liu and F. Li, "A novel high step-up converter with a quasi active switched-inductor structure for renewable energy systems," *IEEE Trans. Power Electron.*, vol. 31, no. 7, pp. 5030–5039, Jul. 2015.
- [95] H. C. Liu and F. Li, "Novel high step-up DC-DC converter with an active coupled-inductor network for a sustainable energy system," *IEEE Trans. Power Electron.*, vol. 30, no. 12, pp. 6476–6482, Dec. 2015.
- [96] B. Axelrod, Y. Berkovich, S. Tapuchi, and A. Ioinovici, "Improved circuit of the switched coupled-inductor cell for DC-DC converters with very large conversion ratio," in *Proc. 13th Eur. Conf. Power Electron. Appl.*, 2009, pp. 1–10.
- [97] B. Axelrod, Y. Berkovich, and A. Ioinovici, "Switched coupled-inductor cell for DC-DC converters with very large conversion ratio," in *Proc. 32nd Annu. Conf. IEEE Ind. Electron. Soc.*, 2006, pp. 2366–2371.
- [98] Y. Berkovich and B. Axelrod, "Switched-coupled inductor cell for DC-DC converters with very large conversion ratio," *IET Power Electron.*, vol. 4, no. 3, pp. 309–315, 2011.
- [99] B. Axelrod and Y. Berkovich, "New coupled-inductor SEPIC converter with very high conversion ratio and reduced voltage stress on the switches," in *Proc. IEEE 33rd Int. Telecommun. Energy Conf.*, 2011, pp. 1–7.
- [100] B. Axelrod, Y. Berkovich, S. Tapuchi, and A. Ioinovici, "Steep conversion ration Cuk, Zeta, and Sepic converters based on a switched coupled-inductor cell," in *Proc. IEEE Power Electron. Spec. Conf.*, 2008, pp. 3009–3014.
- [101] S. M. Chen, M. L. Lao, Y. H. Hsieh, T. J. Liang, and K. H. Chen, "A novel switched-coupled-inductor DC-DC step-up converter and Its derivatives," *IEEE Trans. Ind. Appl.*, vol. 51, no. 1, pp. 309–314, Jan./Feb. 2015.
- [102] N. Vazquez, L. Estrada, C. Hernandez, and E. Rodriguez, "The tapped-inductor boost converter," in *Proc. IEEE Int. Symp. Ind. Electron.*, 2007, pp. 538–543.
- [103] K. W. E. Cheng, "Tapped inductor for switched-mode power converters," in *Proc. 2nd Int. Conf. Power Electron. Syst. Appl.*, 2006, pp. 14–20.
- [104] D. A. Grant, Y. Darroman, and J. Suter, "Synthesis of tapped-inductor switched-mode converters," *IEEE Trans. Power Electron.*, vol. 22, no. 5, pp. 1964–1969, Sep. 2007.
- [105] N. Vazquez, F. Medina, C. Hernandez, J. Arau and E. Vazquez., "Double tapped-inductor boost converter," *IET Power Electron.*, vol. 8, no. 5, pp. 831–840, 2015.
- [106] Z. H. Shi, K. W. E. Cheng, and S. L. Ho, "Static performance and parasitic analysis of tapped-inductor converters," *IET Power Electron.*, vol. 7, no. 2, pp. 366–375, 2014.
- [107] J. I. Kang, J. Han, and S. K. Han, "Lossless snubber for tapped-inductor boost converter for high step-up application," in *Proc. IEEE Int. Conf. Ind. Technol.*, 2014, pp. 253–260.
- [108] Q. Zhao and F. C. Lee, "High-efficiency, high step-up DC-DC converters," *IEEE Trans. Power Electron.*, vol. 18, no. 1, pp. 65–73, Jan. 2003.
- [109] R. J. Wai and R. Y. Duan, "High step-up converter with coupled-inductor," *IEEE Trans. Power Electron.*, vol. 20, no. 5, pp. 1025–1035, Sep. 2005.

- [110] W. Yu *et al.*, “High efficiency converter with charge pump and coupled inductor for wide input photovoltaic AC module applications,” in *Proc. IEEE Energy Convers. Congr. Expo.*, 2009, pp. 3895–3900.
- [111] Y. P. Hsieh, J. F. Chen, T. J. Liang, and L. S. Yang, “Novel high step-up DC-DC converter for distributed generation system,” *IEEE Trans. Ind. Electron.*, vol. 60, no. 4, pp. 1473–1482, Apr. 2013.
- [112] R. J. Wai, C. Y. Lin, R. Y. Duan, and Y. R. Chang, “High-efficiency DC-DC converter with high voltage gain and reduced switch stress,” *IEEE Trans. Ind. Electron.*, vol. 54, no. 1, pp. 354–364, Feb. 2007.
- [113] Y. P. Siwakoti, P. C. Loh, F. Blaabjerg, S. J. Andreasen, and G. E. Town, “Y-source boost DC/DC converter for distributed generation,” *IEEE Trans. Ind. Electron.*, vol. 62, no. 2, pp. 1059–1069, Feb. 2015.
- [114] L. S. Yang, T. J. Liang, H. C. Lee, and J. F. Chen, “Novel high step-up DC-DC converter with coupled-inductor and voltage-doubler circuits,” *IEEE Trans. Ind. Electron.*, vol. 58, no. 9, pp. 4196–4206, Sep. 2011.
- [115] Y. P. Siwakoti, F. Blaabjerg and P. C. Loh, “Ultra-step-up DC-DC converter with integrated autotransformer and coupled inductor,” in *Proc. IEEE Appl. Power Electron. Conf. Expo.*, 2016, pp. 1872–1877.
- [116] E. Lefeuvre, D. Audigier, C. Richard, and D. Guyomar, “Buck-boost converter for sensorless power optimization of piezoelectric energy harvester,” *IEEE Trans. Power Electron.*, vol. 22, no. 5, pp. 2018–2025, Sep. 2007.
- [117] D. D. C. Lu and V. G. Agelidis, “Photovoltaic-battery-powered DC bus system for common portable electronic devices,” *IEEE Trans. Power Electron.*, vol. 24, no. 3, pp. 849–855, Mar. 2009.
- [118] B. Sahu and G. A. Rincon-Mora, “A low voltage, dynamic, noninverting, synchronous buck-boost converter for portable applications,” *IEEE Trans. Power Electron.*, vol. 19, no. 2, pp. 443–452, Mar. 2004.
- [119] Q. Zhao, Y. Hu, F. C. Lee, J. A. Sabate, and F. Li, “A high efficiency DC/DC converter as the front-end stage of high intensity discharge lamp ballasts for automobiles,” in *Proc. 3rd Int. Power Electron. Motion Control Conf.*, 2000, vol. 2, pp. 752–756.
- [120] C. S. Chae, H. P. Le, K. C. Lee, G. H. Cho, and G. H. Cho, “A single-inductor step-up DC-DC switching converter with bipolar outputs for active matrix OLED mobile display panels,” *IEEE J. Solid-State Circuits*, vol. 44, no. 2, pp. 509–524, Feb. 2009.
- [121] Q. Zhao, F. Tao, and F. C. Lee, “A front-end DC/DC converter for network server applications,” in *Proc. IEEE Power Electron. Spec. Conf.*, 2001, vol. 3, pp. 1535–1539.
- [122] S. K. Changchien, T. J. Liang, J. F. Chen, and L. S. Yang, “Novel high step-up DC-DC converter for fuel cell energy conversion system,” *IEEE Trans. Ind. Electron.*, vol. 57, no. 6, pp. 2007–2017, Jun. 2010.
- [123] T. M. Andersen *et al.*, “A 10 W on-chip switched capacitor voltage regulator with feedforward regulation capability for granular microprocessor power delivery,” *IEEE Trans. Power Electron.*, vol. 32, no. 1, pp. 378–393, Jan. 2017.
- [124] K. I. Hwu and Y. T. Yau, “KY converter and its derivatives,” *IEEE Trans. Power Electron.*, vol. 24, no. 1, pp. 128–137, Jan. 2009.
- [125] A. Mostaan, E. Alizadeh, and M. Soltani, “Novel step-up DC/DC converter with no right half plane zero and reduced switched voltage stress characteristics,” in *Proc. IEEE 36th Int. Telecommun. Energy Conf.*, 2014, pp. 1–7.
- [126] M. Soltani, A. Mostaan, Y. P. Siwakoti, P. Davari, and F. Blaabjerg, “Family of step-up DC/DC converters with fast dynamic response for low power applications,” *IET Power Electron.*, vol. 9, no. 14, pp. 2665–2673, 2016.
- [127] D. Wang, X. He, and R. Zhao, “ZVT interleaved boost converters with built-in voltage doubler and current auto-balance characteristic,” *IEEE Trans. Power Electron.*, vol. 23, no. 6, pp. 2847–2854, Nov. 2008.
- [128] W. Li and X. He, “A family of interleaved DC-DC converters deduced from a basic cell with winding-cross-coupled inductors (WCCLs) for high step-up or step-down conversions,” *IEEE Trans. Power Electron.*, vol. 23, no. 4, pp. 1791–1801, Jul. 2008.
- [129] W. Li and X. He, “ZVT interleaved boost converters for high-efficiency, high step-up DC-DC conversion,” *IET Electr. Power Appl.*, vol. 1, no. 2, pp. 284–290, 2007.
- [130] Y. Lu, H. Liu, H. Hu, H. Wu, and Y. Xing, “Single-switch high step-up converter with coupled-inductor and built-in transformer,” in *Proc. IEEE 10th Conf. Ind. Electron. Appl.*, 2015, pp. 1181–1186.
- [131] D. Cao and F. Z. Peng, “Zero-current-switching multilevel modular switched-capacitor DC-DC converter,” *IEEE Trans. Ind. Appl.*, vol. 46, no. 6, pp. 2536–2544, Nov./Dec. 2010.
- [132] K. K. Law, K. W. E. Cheng, and Y. P. B. Yeung, “Design and analysis of switched-capacitor-based step-up resonant converters,” *IEEE Trans. Circuits Syst. I, Reg. Papers*, vol. 52, no. 5, pp. 943–948, May 2005.
- [133] Y. Lei and R. C. N. Pilawa-Podgurski, “A general method for analyzing resonant and soft-charging operation of switched-capacitor converters,” *IEEE Trans. Power Electron.*, vol. 30, no. 10, pp. 5650–5664, Oct. 2015.
- [134] S. R. Sanders, E. Alon, H. P. Le, M. D. Seeman, M. John, and V. W. Ng, “The road to fully integrated DC–DC conversion via the switched-capacitor approach,” *IEEE Trans. Power Electron.*, vol. 28, no. 9, pp. 4146–4155, Sep. 2013.
- [135] Y. Lei and R. C. N. Pilawa-Podgurski, “A general method for analyzing resonant and soft-charging operation of switched-capacitor converters,” *IEEE Trans. Power Electron.*, vol. 30, no. 10, pp. 5650–5664, Oct. 2015.
- [136] T. S. Wu, Y. S. Lai, J. C. Hung, and Y. M. Chen, “Boost converter with coupled inductors and buck-boost type of active clamp,” *IEEE Trans. Ind. Electron.*, vol. 55, no. 1, pp. 154–162, Jan. 2008.
- [137] Y. Tang, D. Fu, J. Kan, and T. Wang, “Dual switches DC/DC converter with three-winding-coupled inductor and charge pump,” *IEEE Trans. Power Electron.*, vol. 31, no. 1, pp. 461–469, Jan. 2016.
- [138] Y. Jang and M. M. Jovanovic, “New two-inductor boost converter with auxiliary transformer,” *IEEE Trans. Power Electron.*, vol. 19, no. 1, pp. 169–175, Jan. 2004.
- [139] C. M. Young, M. H. Chen, T. A. Chang, C. C. Ko, and K. K. Jen, “Cascade Cockcroft-Walton voltage multiplier applied to transformerless high step-up DC-DC converter,” *IEEE Trans. Ind. Electron.*, vol. 60, no. 2, pp. 523–537, Feb. 2013.
- [140] J. A. Morales-Saldana, E. E. C. Gutierrez, and J. Leyva-Ramos, “Modeling of switch-mode DC-DC cascade converters,” *IEEE Trans. Aerosp. Electron. Syst.*, vol. 38, no. 1, pp. 295–299, Jan. 2002.
- [141] J. Leyva-Ramos, M. G. Ortiz-Lopez, L. H. Diaz-Saldierna, and J. A. Morales-Saldana, “Switching regulator using a quadratic boost converter for wide DC conversion ratios,” *IET Power Electron.*, vol. 2, no. 5, pp. 605–613, 2009.
- [142] M. G. Ortiz-Lopez, J. Leyva-Ramos, E. E. Carbajal-Gutierrez, and J. A. Morales-Saldana, “Modelling and analysis of switch-mode cascade converters with a single active switch,” *IET Power Electron.*, vol. 1, no. 4, pp. 478–487, 2008.
- [143] Y. R. D. Novaes, I. Barbi, and A. Rufer, “A new three-level quadratic (T-LQ) DC-DC converter suitable for fuel cell applications,” *IEEE Trans. Ind. Appl.*, vol. 128, no. 4, pp. 459–467, 2008.
- [144] D. S. Wijeratne and G. Moschopoulos, “Quadratic power conversion for power electronics: principles and circuits,” *IEEE Trans. Circuits Syst. I, Reg. Papers*, vol. 59, no. 2, pp. 426–438, Feb. 2012.
- [145] Y. M. Ye and K. W. E. Cheng, “Quadratic boost converter with low buffer capacitor stress,” *IET Power Electron.*, vol. 7, no. 5, pp. 1162–1170, 2014.
- [146] J. P. Gaubert and G. Chanedeau, “Evaluation of DC-to-DC converters topologies with quadratic conversion ratios for photovoltaic power systems,” in *Proc. 13th Eur. Conf. Power Electron. Appl.*, 2009, pp. 1–10.
- [147] B. R. Lin and J. J. Chen, “Analysis and implementation of a soft switching converter with high-voltage conversion ratio,” *IET Power Electron.*, vol. 1, no. 3, pp. 386–394, 2008.
- [148] S. M. Chen, T. J. Liang, L. S. Yang, and J. F. Chen, “A cascaded high step-up DC-DC converter with single switch for microsource applications,” *IEEE Trans. Power Electron.*, vol. 26, no. 4, pp. 1146–1153, Apr. 2011.
- [149] S.M. Chen, T.J. Liang, L.S. Yang, J.F. Chen, and K.C. Juang, “A quadratic high step-up DC-DC converter with voltage multiplier,” in *Proc. IEEE Int. Elect. Mach. Drives Conf.*, 2011, pp. 1025–1029.
- [150] X. Hu and C. Gong, “A high voltage gain DC-DC converter integrating coupled-inductor and diode-capacitor techniques,” *IEEE Trans. Power Electron.*, vol. 29, no. 2, pp. 789–800, Feb. 2014.
- [151] Y. S. Lee, Z. H. Chou, S.S. Huang, and S. Y. Huang, “Quadratic boost converter with switched capacitor and coupled inductor for PV system applications,” in *Proc. IEEE 10th Int. Conf. Power Electron. Drive Syst.*, 2013, pp. 38–43.
- [152] M. S. Lin, L. S. Yang, and T. J. Liang, “Study and implementation of a single switch cascading high step-up DC-DC converter,” in *Proc. IEEE Int. Conf. Power Electron.*, 2011, pp. 2565–2572.
- [153] N. Zhang, D. Sutanto, K. M. Muttaqi, B. Zhang, and D. Qiu, “High-voltage-gain quadratic boost converter with voltage multiplier,” *IET Power Electron.*, vol. 8, no. 12, pp. 2511–2519, 2015.
- [154] K. D. Kim, J. G. Kim, Y. C. Jung, and C. Y. Won, “Improved non-isolated high voltage gain boost converter using coupled inductors,” in *Proc. Int. Conf. Electr. Mach. Syst.*, 2011, pp. 1–6.
- [155] A. M. S. S. Andrade, L. Schuch, and M. L. da S. Martins, “Very high voltage step-up integrated quadratic-boost-zeta converter,” in *Proc. IEEE Int. Symp. Ind. Electron.*, 2015, pp. 422–427.

- [156] F. L. Tofoli *et al.*, "Proposal of a switched mode power supply employing a quadratic boost converter and a new topology of soft-switched two-switch forward converter," in *Proc. IEEE 19th Annu. Appl. Power Electron. Conf. Expo.*, 2004, pp. 1384–1388.
- [157] A. Shahin, M. Hinaje, J. P. Martin, S. Pierfederici, S. Rae, and B. Davat, "High voltage ratio DC-DC converter for fuel-cell applications," *IEEE Trans. Ind. Electron.*, vol. 57, no. 12, pp. 3944–3955, Dec. 2010.
- [158] J. Fu, B. Zhang, D. Qiu, and W. Xiao, "A novel single-switch cascaded DC-DC converter of boost and buck-boost converters," in *Proc. 16th Eur. Conf. Power Electron. Appl.*, 2014, pp. 1–9.
- [159] R. Gules, L. L. Pfitscher, and L. C. Franco, "An interleaved boost DC-DC converter with large conversion ratio," in *Proc. IEEE Int. Symp. Ind. Electron.*, 2003, vol. 1, pp. 411–416.
- [160] X. Zhang and T. C. Green, "The modular multilevel converter for high step-up ratio DC-DC conversion," *IEEE Trans. Ind. Electron.*, vol. 62, no. 8, pp. 4925–4936, Aug. 2015.
- [161] J. C. Rosas-Caro, J. M. Ramirez, F. Z. Peng, and A. Valderrabano, "A DC-DC multilevel boost converter," *IET Power Electron.*, vol. 3, no. 1, pp. 129–137, 2010.
- [162] M. Prudente, L. L. Pfitscher, and R. Gules, "A boost converter with voltage multiplier cells," in *Proc. IEEE Power Electron. Spec. Conf.*, 2005, pp. 2716–2721.
- [163] B. Axelrod, Y. Berkovich, and A. Ioinovici, "Transformerless DC-DC converters with a very high DC line-to-load voltage ratio," in *Proc. Int. Symp. Circuits Syst.*, 2003, vol. 3, pp. III-435–III-438.
- [164] Y. J. A. Alcazar, D. D. S. Oliveira, F. L. Tofoli, and R. P. Torrico-Bascope, "DC-DC nonisolated boost converter based on the three-state switching cell and voltage multiplier cells," *IEEE Trans. Ind. Electron.*, vol. 60, no. 10, pp. 4438–4449, Oct. 2013.
- [165] F. L. Tofoli, D. D. S. Oliveira, R. P. Torrico-Bascope, and Y. J. A. Alcazar, "Novel nonisolated high-voltage gain DC-DC converters based on 3SSC and VMC," *IEEE Trans. Power Electron.*, vol. 27, no. 9, pp. 3897–3907, Sep. 2012.
- [166] Y. Berkovich, B. Axelrod, and A. Shenkman, "A novel diode-capacitor voltage multiplier for increasing the voltage of photovoltaic cells," in *Proc. IEEE 11th Workshop Control Model. Power Electron.*, 2008, pp. 1–5.
- [167] Y. Zhao, X. Xiang, C. Li, Y. Gu, W. Li, and X. He, "Single-phase high step-up converter with improved multiplier cell suitable for half-bridge-based PV inverter system," *IEEE Trans. Power Electron.*, vol. 29, no. 6, pp. 2807–2816, Jun. 2014.
- [168] S. Lee, P. Kim, and S. Choi, "High step-up soft-switched converters using voltage multiplier cells," *IEEE Trans. Power Electron.*, vol. 28, no. 7, pp. 3379–3387, Jul. 2013.
- [169] L. Muller and J. W. Kimball, "High gain DC-DC converter based on the Cockcroft-Walton multiplier," *IEEE Trans. Power Electron.*, vol. 31, no. 9, pp. 6405–6415, Sep. 2016.
- [170] C. M. Young, M. H. Chen, T. A. Chang, C. C. Ko, and K. K. Jen, "Cascade Cockcroft-Walton voltage multiplier applied to transformerless high step-up DC-DC converter," *IEEE Trans. Ind. Electron.*, vol. 60, no. 2, pp. 523–537, Feb. 2013.
- [171] M. Zhu and F. L. Luo, "Series SEPIC implementing voltage-lift technique for DC-DC power conversion," *IET Power Electron.*, vol. 1, no. 1, pp. 109–121, 2008.
- [172] Y. Gu, D. Zhang, and Z. Zhao, "Input current ripple cancellation technique for boost converter using tapped inductor," *IEEE Trans. Ind. Electron.*, vol. 61, no. 10, pp. 5323–5333, Oct. 2014.
- [173] Y. P. Siwakoti, F. Blaabjerg, and P. C. Loh, "Quasi-Y-source boost DC-DC converter," *IEEE Trans. Power Electron.*, vol. 30, no. 12, pp. 6514–6519, Dec. 2015.
- [174] Y. P. Siwakoti, F. Blaabjerg and P. Chiang Loh, "High step-up transinverse (T_x^{-1}) DC-DC converter for the distributed generation system," *IEEE Trans. Ind. Electron.*, vol. 63, no. 7, pp. 4278–4291, Jul. 2016.
- [175] K. B. Park, G. W. Moon, and M. J. Youn, "Nonisolated high step-up boost converter integrated with Sepic converter," *IEEE Trans. Power Electron.*, vol. 25, no. 9, pp. 2266–2275, Sep. 2010.
- [176] A. Richelli, S. Comensoli, and Z. M. Kovacs-Vajna, "A DC/DC boosting technique and power management for ultralow-voltage energy harvesting applications," *IEEE Trans. Ind. Electron.*, vol. 59, no. 6, pp. 2701–2708, Jun. 2012.
- [177] A. Richelli, L. Colalongo, S. Tonoli, and Z. M. Kovacs-Vajna, "A 0.2–1.2V DC/DC boost converter for power harvesting applications," *IEEE Trans. Power Electron.*, vol. 24, no. 6, pp. 1541–1546, Jun. 2009.
- [178] J.-H. Huang, B. Lehman, and T. Qian, "Submodule integrated boost DC-DC converters with no external input capacitor or input inductor for low power photovoltaic applications," in *Proc. IEEE Energy Convers. Congr. Expo.*, 2016, pp. 1–7.
- [179] D. Zhang, F. Yang, T. Shimotori, K.-C. Wang, and Y. Huang, "Performance evaluation of power management systems in microbial fuel cell-based energy harvesting applications for driving small electronic devices," *J. Power Sources*, vol. 217, pp. 65–71, 2012.
- [180] E. J. Carlson, K. Strunz, and B. P. Otis, "A 20 mV input boost converter with efficient digital control for thermoelectric energy harvesting," *IEEE J. Solid-State Circuits*, vol. 45, no. 4, pp. 741–750, Apr. 2010.
- [181] X. Cao, W. J. Chiang, Y. C. King, and Y. K. Lee, "Electromagnetic energy harvesting circuit with feedforward and feedback DC-DC PWM boost converter for vibration power generator system," *IEEE Trans. Power Electron.*, vol. 22, no. 2, pp. 679–685, Mar. 2007.
- [182] X. Xu and X. Wu, "High dimming ratio LED driver with fast transient boost converter," in *Proc. IEEE Power Electron. Spec. Conf.*, 2008, pp. 4192–4195.
- [183] C. Y. Hsieh and K. H. Chen, "Boost DC-DC converter with fast reference tracking (FRT) and charge-recycling (CR) techniques for high-efficiency and low-cost LED driver," *IEEE J. Solid-State Circuits*, vol. 44, no. 9, pp. 2568–2580, Sep. 2009.
- [184] C. A. Canesin, F. A. S. Goncalves, G. A. Melo, and L. C. de Freitas, "DCM boost interleaved converter for operation in AC and DC to trolleybus application," in *Proc. 13th Eur. Conf. Power Electron. Appl.*, 2009, pp. 1–10.
- [185] Y. Liu, C. Farnell, J. C. Balda, and H. A. Mantooth, "Design of a 2 MW DC supply using a 4-stage interleaved DC-DC converter," in *Proc. Energy Convers. Congr. Expo.*, 2014, pp. 964–970.
- [186] Y. Jang and M. M. Jovanovic, "Interleaved boost converter with intrinsic voltage-doubler characteristic for universal-line PFC front end," *IEEE Trans. Power Electron.*, no. 4, vol. 22, pp. 1394–1401, Jul. 2007.
- [187] J. J. Yun, H. J. Choe, and C. Lee, "A new high efficiency boost LED driver circuit for edge-lit LED backlight units," in *Proc. TENCON Conf.*, 2015, pp. 1–3.
- [188] D. Jovicic, "Step-up DC-DC converter for megawatt size applications," *IET Power Electron.*, vol. 2, no. 6, pp. 675–685, 2009.
- [189] D. M. Sable, B. H. Cho, and R. Ridley, "Elimination of the positive zero in fixed frequency boost and flyback converters," in *Proc. 5th Annu. Appl. Power Electron. Conf. Expo.*, 1990, pp. 205–211.
- [190] W. C. Wu, R. M. Bass, and J. R. Yeargan, "Eliminating the effects of the right-half plane zero in fixed frequency boost converters," in *Proc. IEEE Power Electron. Spec. Conf.*, 1998, pp. 362–366.
- [191] V. Yousefzadeh, M. Shirazi, and D. Maksimovic, "Minimum phase response in digitally controlled boost and flyback converters," in *Proc. IEEE Appl. Power Electron. Conf. Expo.*, 2007, pp. 865–870.
- [192] Z. Chen, W. Gao, J. Hu, and X. Ye, "Closed-loop analysis and cascade control of a nonminimum phase boost converter," *IEEE Trans. Power Electron.*, vol. 26, no. 4, pp. 1237–1252, Apr. 2011.
- [193] T. T. Song and H. S. H. Chung, "Boundary control of boost converters using state-energy plane," *IEEE Trans. Power Electron.*, vol. 23, no. 2, pp. 551–563, Mar. 2008.
- [194] S. C. Tan, Y. M. Lai, C. K. Tse, L. Martinez-Salamero, and C. K. Wu, "A fast-response sliding-mode controller for boost-type converters with a wide range of operating conditions," *IEEE Trans. Ind. Electron.*, vol. 54, no. 6, pp. 3276–3286, Dec. 2007.
- [195] K. Kittipeerachon and C. Bunlaksananusorn, "Feedback compensation design for switched mode power supplies with a right-half plane (RHP) zero," in *Proc. 2nd Int. Conf. Power Electron., Mach. Drives*, 2004, pp. 236–241.
- [196] K. Kittipeerachon, and C. Bunlaksananusorn, "A current-controlled tristate boost converter with improved performance through RHP zero elimination," *IEEE Trans. Power Electron.*, vol. 24, no. 3, pp. 776–786, Mar. 2009.
- [197] J. L. White and W. J. Muldoon, "Two-inductor boost and buck converters," in *Proc. IEEE Power Electron. Spec. Conf.*, 1987, pp. 387–392.
- [198] P. Rueda, S. Ghani, and P. Perol, "A new energy transfer principle to achieve a minimum phase & continuous current boost converter," in *Proc. IEEE Power Electron. Spec. Conf.*, 2004, vol. 3, pp. 2232–2236.
- [199] J. Calvente, L. Martinez-Salamero, H. Valderrama, and E. Vidal-Idiarte, "Using magnetic coupling to eliminate right half-plane zeros in boost converters," *IEEE Power Electron. Lett.*, vol. 2, no. 2, pp. 58–62, Jun. 2004.

- [200] D. Diaz, O. Garcia, J. A. Oliver, P. Alou, and J. A. Cobos, "Analysis and design considerations for the right-half-plane zero cancellation on a boost derived DC/DC converter," in *Proc. IEEE Power Electron. Spec. Conf.*, 2008, pp. 3825–3828.
- [201] Y. Gu, D. Zhang, and Z. Zhao, "Input/output current ripple cancellation and RHP zero elimination in a boost converter using an integrated magnetic technique," *IEEE Trans. Power Electron.*, vol. 30, no. 2, pp. 747–756, Feb. 2015.
- [202] H. Liu, D. Zhang, "Two-phase interleaved inverse-coupled inductor boost without right half plane zeros," *IEEE Trans. Power Electron.*, vol. 32, no. 3, pp. 1844–1859, Mar. 2017.
- [203] M. Forouzesh, K. Yari, A. Baghrarian and S. Hasanpour, "Single-switch high step-up converter based on coupled inductor and switched capacitor techniques with quasi-resonant operation," *IET Power Electron.*, vol. 10, no. 2, pp. 240–250, 2017.
- [204] L. H. S. C. Barreto, E. A. A. Coelho, V. J. Farias, J. C. de Oliveira, L. C. de Freitas, and J. B. Vieira, "A quasi-resonant quadratic boost converter using a single resonant network," *IEEE Trans. Ind. Electron.*, vol. 52, no. 2, pp. 552–557, Apr. 2005.
- [205] W. Li, W. Li, and X. He, "Zero-voltage transition interleaved high step-up converter with built-in transformer," *IET Power Electron.*, vol. 4, no. 5, pp. 523–531, 2011.
- [206] W. Li, X. Xiang, C. Li, W. Li, and X. He, "Interleaved high step-up ZVT converter with built-in transformer voltage doubler cell for distributed PV generation system," *IEEE Trans. Power Electron.*, vol. 28, no. 1, pp. 300–313, Jan. 2013.
- [207] Y. Deng, Q. Rang, W. Li, Y. Zhao, J. Shi, and X. He, "Single-switch high step-up converters with built-in transformer voltage multiplier cell," *IEEE Trans. Power Electron.*, vol. 27, no. 8, pp. 3557–3567, Aug. 2012.
- [208] K. B. Park, G. W. Moon, and M. J. Youn, "Nonisolated high step-up stacked converter based on boost-integrated isolated converter," *IEEE Trans. Power Electron.*, vol. 26, no. 2, pp. 577–587, Feb. 2011.
- [209] H. L. Do, "A soft-switching DC/DC converter with high voltage gain," *IEEE Trans. Power Electron.*, vol. 25, no. 5, pp. 1193–1200, May 2010.
- [210] K. B. Park, G. W. Moon, and M. J. Youn, "High step-up boost converter integrated with a transformer-assisted auxiliary circuit employing quasi-resonant operation," *IEEE Trans. Power Electron.*, vol. 27, no. 4, pp. 1974–1984, Apr. 2012.
- [211] W. Li, W. Li, X. He, D. Xu, and B. Wu, "General derivation law of non-isolated high-step-up interleaved converters with built-in transformer," *IEEE Trans. Ind. Electron.*, vol. 59, no. 3, pp. 1650–1661, Mar. 2012.
- [212] W. Li, W. Li, Y. Deng, and X. He, "Single-stage single-phase high-step-up ZVT boost converter for fuel-cell microgrid system," *IEEE Trans. Power Electron.*, vol. 25, no. 12, pp. 3057–3065, Dec. 2010.
- [213] Y. Du, X. Zhou, S. Bai, S. Lukic, and A. Huang, "Review of non-isolated bi-directional DC-DC converters for plug-in hybrid electric vehicle charge station application at municipal parking decks," in *Proc. IEEE Appl. Power Electron. Conf. Expo.*, 2010, pp. 1145–1151.
- [214] N. Jabbour and C. Mademlis, "Improved Control Strategy of a Supercapacitor-based energy recovery system for elevator applications," *IEEE Trans. Power Electron.*, vol. 31, no. 12, pp. 8398–8408, Dec. 2016.
- [215] F. H. Khan and L. M. Tolbert, "Bi-directional power management and fault tolerant feature in a 5-kW multilevel dc-dc converter with modular architecture," *IET Power Electron.*, vol. 2, no. 5, pp. 595–604, 2009.
- [216] F. H. Khan and L. M. Tolbert, "Multiple-load-source integration in a multilevel modular capacitor-clamped DC-DC converter featuring fault tolerant capability," *IEEE Trans. Power Electron.*, vol. 24, no. 1, pp. 14–24, Jan. 2009.
- [217] F. H. Khan and L. M. Tolbert, "A multilevel modular capacitor-clamped DC-DC converter," *IEEE Trans. Ind. Appl.*, no. 6, vol. 43, pp. 1628–1638, Nov./Dec. 2007.
- [218] B. M. Han, "Grid-tied power converter for battery energy storage composed of 2-stage DC-DC converter," in *Proc. IEEE Power Energy Soc. Gen. Meeting*, 2013, pp. 1–5.
- [219] Y. Chen, A. Q. Huang, and X. Yu, "A high step-up three-port DC-DC converter for stand-alone PV/battery power systems," *IEEE Trans. Power Electron.*, vol. 28, no. 11, pp. 5049–5062, Nov. 2013.
- [220] W. Qian, H. Cha, F. Z. Peng, and L. M. Tolbert, "55-kW variable 3X DC-DC converter for plug-in hybrid electric vehicles," *IEEE Trans. Power Electron.*, vol. 27, no. 4, pp. 1668–1678, Apr. 2012.
- [221] Z. Li, S. Hoshina, N. Satake and M. Nogi, "Development of DC/DC converter for battery energy storage supporting railway DC feeder systems," *IEEE Trans. Ind. Appl.*, vol. 52, no. 5, pp. 4218–4224, Sept./Oct. 2016.
- [222] P. Garcia, L. M. Fernandez, C. A. Garcia, and F. Jurado, "Energy management system of fuel-cell-battery hybrid tramway," *IEEE Trans. Ind. Electron.*, vol. 57, no. 12, pp. 4013–4023, Dec. 2010.
- [223] Q. Li *et al.*, "Development of energy management system based on a power sharing strategy for a fuel cell-battery-supercapacitor hybrid tramway," *J. Power Sources*, vol. 279, pp. 267–280, Apr. 2015.
- [224] C. C. Lin, L. S. Yang and E. C. Chang, "Study of a DC-DC converter for solar LED street lighting," in *Proc. IEEE Int. Symp. Next-Gen. Electron.*, 2013, pp. 461–464.
- [225] C. Yao, X. Ruan, X. Wang, and C. K. Tse, "Isolated buck-boost DC/DC converters suitable for wide input-voltage range," *IEEE Trans. Power Electron.*, vol. 26, no. 9, pp. 2599–2613, Sep. 2011.
- [226] A. Chub, D. Vinnikov, F. Blaabjerg, and F. Z. Peng, "A review of galvanically isolated impedance-source DC-DC converters," *IEEE Trans. Power Electron.*, vol. 31, no. 1, pp. 2808–2828, Apr. 2016.
- [227] S. D. Johnson, A. F. Witulski, and R. W. Erickson, "Comparison of resonant topologies in high-voltage DC applications," *IEEE Trans. Aerosp. Electron. Syst.*, vol. 24, no. 3, pp. 263–274, May 1988.
- [228] R. L. Steigerwald, R. W. De Doncker, and M. H. Kheraluwala, "A comparison of high-power DC-DC soft-switched converter topologies," *IEEE Trans. Ind. Appl.*, vol. 32, no. 5, pp. 1139–1145, Sep./Oct. 1996.
- [229] D. Vinnikov and I. Roasto, "Quasi-Z-source-based isolated DC/DC converters for distributed power generation," *IEEE Trans. Ind. Electron.*, vol. 58, pp. no. 1, 192–201, Jan. 2011.
- [230] Y. P. Siwakoti, F. Blaabjerg, P. C. Loh, and G. E. Town, "High-voltage boost quasi-Z-source isolated DC/DC converter," *IET Power Electron.*, vol. 7, no. 9, pp. 2387–2395, 2014.
- [231] M. Forouzesh and A. Baghrarian, "Galvanically isolated high gain Y-source DC-DC converters for dispersed power generation," *IET Power Electron.*, vol. 9, no. 6, pp. 1192–1203, May 18, 2016.
- [232] M. Mohr and F. W. Fuchs, "Voltage fed and current fed full bridge converter for the use in three phase grid connected fuel cell systems," in *Proc. CES/IEEE 5th Int. Power Electron. Motion Control*, 2006, pp. 1–7.
- [233] Y. Zhu and B. Lehman, "Three-level switching cell for low voltage/high-current dc-dc converters," *IEEE Trans. Power Electron.*, vol. 22, no. 5, pp. 1997–2007, Sep. 2007.
- [234] L. Yan, D. Qu, and B. Lehman, "Integrated magnetic full wave converter with flexible output inductor," *IEEE Trans. Power Electron.*, vol. 18, no. 2, pp. 670–678, Mar 2003.
- [235] W. Song and B. Lehman, "Dual-bridge DC-DC converter: A new topology characterized with no deadtime operation," *IEEE Trans. Power Electron.*, vol. 19, no. 1, pp. 94–103, Jan. 2004.
- [236] J. Echeverria, S. Kouro, M. Perez, and H. Abu-Rub, "Multi-modular cascaded DC-DC converter for HVDC grid connection of large-scale photovoltaic power systems," in *Proc. IEEE 39th Annu. Conf. Ind. Electron. Soc.*, 2013, pp. 6999–7005.
- [237] S. Rivera, S. Kouro, B. Wu, J. I. Leon, J. Rodriguez, and L. G. Franquelo, "Cascaded H-bridge multilevel converter multistring topology for large scale photovoltaic systems," in *Proc. IEEE Int. Symp. Ind. Electron.*, 2011, pp. 1837–1844.
- [238] N. H. Kutkut and D. M. Divan, "Dynamic equalization techniques for series battery stacks," in *Proc. IEEE Int. Telecommun. Energy Conf.*, 1996, pp. 514–521.
- [239] A. H. Weinberg and J. Schreuders, "A high-power high-voltage DC-DC converter for space applications," *IEEE Trans. Power Electron.*, vol. PE-1, no. 3, pp. 148–160, Jul. 1986.
- [240] H. J. Chung, "A CW CO₂ laser using a high-voltage DC-DC converter with resonant inverter and Cockroft–Walton multiplier," *Optics Laser Technol.*, vol. 38, pp. 577–584, 2006.
- [241] E. Rotman and S. S. Ben-Yaakov, "Rapid push pull resonant charger for high power, high voltage applications using low input voltage," in *Proc. IEEE Energy Convers. Congr. Expo.*, 2013, pp. 2325–2332.
- [242] T. J. Liang, J. H. Lee, S. M. Chen, J. F. Chen, and L. S. Yang, "Novel isolated high-step-up DC-DC converter with voltage lift," *IEEE Trans. Ind. Electron.*, no. 4, vol. 60, pp. 1483–1491, Apr. 2013.
- [243] D. Y. Kim, J. K. Kim, and G. W. Moon, "A three-level converter with reduced filter size using two transformers and flying capacitors," *IEEE Trans. Power Electron.*, vol. 28, no. 1, pp. 46–53, Jan. 2013.
- [244] Y. K. Cheng and K. W. E. Cheng, "General study for using LED to replace traditional lighting devices," in *Proc. Int. Conf. Power Electron. Syst. Appl.*, 2006, pp. 173–177.
- [245] V. Kumar Chinnaiyan, J. Jerome, J. Karpagam, and S. Shiek Mohammed, "Design and implementation of high power DC-DC converter and speed control of DC motor using TMS320F240 DSP," in *Proc. India Int. Conf. Power Electron.*, 2006, pp. 388–392.
- [246] W. J. Lee, C. E. Kim, G. W. Moon, and S. K. Han, "A new phase-shifted full-bridge converter with voltage-doubler-type rectifier for high-efficiency PDP sustaining power module," *IEEE Trans. Ind. Electron.*, vol. 55, no. 6, pp. 2450–2458, Jun. 2008.

- [247] V. Garcia, M. Rico, J. Sebastian, M. M. Hernando, and J. Uceda, "An optimized DC-to-DC converter topology for high-voltage pulse-load applications," in *Proc. IEEE Power Electron. Spec. Conf.*, 1994, vol. 2, pp. 1413–1421.
- [248] J. Sun, X. Ding, M. Nakaoka, and H. Takano, "Series resonant ZCS-PFM DC-DC converter with multistage rectified voltage multiplier and dual-mode PFM control scheme for medical-use high-voltage X-ray power generator," *IEEE Proc.—Electr. Power Appl.*, vol. 147, no. 6, pp. 527–534, 2000.
- [249] H. Wu, T. Xian, Y. Xing, P. Xu, H. Hu, and Z. Zhang, "Secondary-side phase-shift-controlled high step-up hybrid resonant converter with voltage multiplier for high efficiency PV applications," in *Proc. IEEE Appl. Power Electron. Conf. Expo.*, 2015, pp. 1428–1434.
- [250] H. Mao, J. Abu-Qahouq, S. Lu, and I. Batarseh, "Zero-voltage-switching half-bridge DC-DC converter with modified PWM control method," *IEEE Trans. Power Electron.*, vol. 19, no. 4, pp. 947–958, Jul. 2004.
- [251] S. J. Jeon, F. Canales, P. M. Barbosa, and F. C. Lee, "A primary-side-assisted zero-voltage and zero-current switching three-level DC-DC converter with phase-shift control," in *Proc. IEEE Appl. Power Electron. Conf. Expo.*, 2002, vol. 2, pp. 641–647.
- [252] S. J. Jeon and G. H. Cho, "A zero-voltage and zero-current switching full bridge DC-DC converter with transformer isolation," *IEEE Trans. Power Electron.*, vol. 16, no. 5, pp. 573–580, Sep. 2001.
- [253] J. Zhang, Xie, X. Wu, G. Wu, Z. Qian, "A novel zero-current-transition full bridge DC/DC converter," *IEEE Trans. Power Electron.*, vol. 21, no. 2, pp. 354–360, Mar. 2006.
- [254] H. S. Choi, J. W. Kim, and B. H. Cho, "Novel zero-voltage and zero-current-switching (ZVZCS) full-bridge PWM converter using coupled output inductor," *IEEE Trans. Power Electron.*, vol. 17, no. 5, pp. 641–648, Sep. 2002.
- [255] J. G. Cho, C. Y. Jeong, and F. C. Y. Lee, "Zero-voltage and zero-current-switching full-bridge PWM converter using secondary active clamp," *IEEE Trans. Power Electron.*, vol. 13, no. 4, pp. 601–607, Jul. 1998.
- [256] T. T. Song, N. Huang, and A. Ioinovici, "A family of zero-voltage and zero-current-switching (ZVZCS) three-level DC-DC converters with secondary-assisted regenerative passive snubber," *IEEE Trans. Circuits Syst. I, Reg. Papers*, vol. 52, no. 11, pp. 2473–2481, Nov. 2005.
- [257] E. Chu, X. Hou, H. Zhang, M. Wu, and X. Liu, "Novel zero-voltage and zero-current switching (ZVZCS) PWM three-level DC/DC converter using output coupled inductor," *IEEE Trans. Power Electron.*, vol. 29, no. 3, pp. 1082–1093, Mar. 2014.
- [258] W. Li, D. Xu, B. Wu, Y. Zhao, H. Yang, and X. He, "Zero-voltage-switching dual-boost converter with multi-functional inductors and improved symmetrical rectifier for distributed generation systems," *IET Power Electron.*, vol. 5, no. 7, pp. 969–977, 2012.
- [259] J. H. Lee, T. J. Liang, and J. F. Chen, "Isolated coupled-inductor-integrated DC-DC converter with nondissipative snubber for solar energy applications," *IEEE Trans. Ind. Electron.*, vol. 61, no. 7, pp. 3337–3348, Jul. 2014.
- [260] D. Wang, Y. Deng, and X. He, "Isolated ZVT boost converter with switched capacitors and coupled inductors," in *Proc. IEEE 34th Annu. Conf. IEEE Ind. Electron. Soc.*, 2008, pp. 808–814.
- [261] W. Li and X. He, "A family of isolated interleaved boost and buck converters with winding-cross-coupled inductors," *IEEE Trans. Power Electron.*, vol. 23, no. 6, pp. 3164–3173, Nov. 2008.
- [262] Y. Hu, W. Xiao, W. Li, and X. He, "Three-phase interleaved high-step-up converter with coupled-inductor-based voltage quadrupler," *IET Power Electron.*, vol. 7, no. 7, pp. 1841–1849, 2014.
- [263] J. Elmes, C. Jourdan, O. Abdel-Rahman, and I. Batarseh, "High-voltage, high-power-density DC-DC converter for capacitor charging applications," in *Proc. IEEE Appl. Power Electron. Conf. Expo.*, 2009, pp. 433–439.
- [264] M. Nymand and M. A. E. Andersen, "High-efficiency isolated boost DC-DC converter for high-power low-voltage fuel-cell applications," *IEEE Trans. Ind. Electron.*, vol. 57, no. 2, pp. 505–514, Feb. 2010.
- [265] J. Y. Lee, Y. S. Jeong, and B. M. Han, "An isolated DC/DC converter using high-frequency unregulated LLC resonant converter for fuel cell applications," *IEEE Trans. Ind. Electron.*, vol. 58, no. 7, pp. 2926–2934, Jul. 2011.
- [266] S. S. Dobakhshari, J. Milimonfared, M. Taheri, and H. Moradizkoohi, "A quasi-resonant current-fed converter with minimum switching losses," *IEEE Trans. Power Electron.*, vol. 32, no. 1, pp. 353–362, Jan. 2017.
- [267] J. F. Chen, R. Y. Chen, and T. J. Liang, "Study and implementation of a single-stage current-fed boost PFC converter with ZCS for high voltage applications," *IEEE Trans. Power Electron.*, vol. 23, no. 1, pp. 379–386, Jan. 2008.
- [268] H. Wang, Q. Sun, H. S. H. Chung, S. Tapuchi, and A. Ioinovici, "A ZCS current-fed full-bridge PWM converter with self-adaptable soft-switching snubber energy," *IEEE Trans. Power Electron.*, vol. 24, no. 8, pp. 1977–1991, Aug. 2009.
- [269] A. Mousavi, P. Das and G. Moschopoulos, "A comparative study of a new ZCS dc-dc full-bridge boost converter with a ZVS active-clamp converter," *IEEE Trans. Power Electron.*, vol. 27, no. 3, pp. 1347–1358, Mar. 2012.
- [270] P. J. Wolfs, "A current-sourced DC-DC converter derived via the duality principle from the half-bridge converter," *IEEE Trans. Ind. Electron.*, vol. 40, no. 1, pp. 139–144, Feb. 1993.
- [271] L. Yan and B. Lehman, "An integrated magnetic isolated two-inductor boost converter: analysis, design and experimentation," *IEEE Trans. Power Electron.*, vol. 20, no. 2, pp. 332–342, Mar. 2005.
- [272] W. Song and B. Lehman, "Current-fed dual-bridge DC-DC converter," *IEEE Trans. Power Electron.*, vol. 22, no. 2, pp. 461–469, Mar. 2007.
- [273] J. Wen, T. Jin, and K. Smedley, "A new interleaved isolated boost converter for high power applications," in *Proc. IEEE Appl. Power Electron. Conf. Expo.*, 2006, pp. 19–23.
- [274] Y. Zhao, X. Xiang, W. Li, X. He, and C. Xia, "Advanced symmetrical voltage quadrupler rectifiers for high step-up and high output-voltage converters," *IEEE Trans. Ind. Electron.*, vol. 28, no. 4, pp. 1622–1631, Apr. 2013.
- [275] K. C. Tseng, C. C. Huang, and C. A. Cheng, "A high step-up converter with voltage-multiplier modules for sustainable energy applications," *IEEE J. Emerg. Sel. Topics Power Electron.*, vol. 3, no. 4, pp. 1100–1108, Dec. 2015.
- [276] I. Barbi and R. Gules, "Isolated DC-DC converters with high-output voltage for TWTA telecommunication satellite applications," *IEEE Trans. Power Electron.*, vol. 18, no. 4, pp. 975–984, Jul. 2003.
- [277] M. Chen, K. K. Afridi, S. Chakraborty, and D. J. Perreault, "Multitrack power conversion architecture," *IEEE Trans. Power Electron.*, vol. 32, no. 1, pp. 325–340, Jan. 2017.
- [278] J. Zhang, "Bidirectional dc-dc power converter design, optimization, modeling and control." Ph.D. dissertation, Virginia Polytechnic Inst. State Univ., Blacksburg, VA, USA, 2008.
- [279] A. K. Rathore and U. Prasanna, "Comparison of soft-switching voltage-fed and current-fed bi-directional isolated Dc/Dc converters for fuel cell vehicles," in *Proc. IEEE Int. Symp. Ind. Electron.*, 2012, pp. 252–257.
- [280] B. Zhao, Q. Song, W. Liu, and Y. Sun, "Overview of dual-active-bridge isolated bidirectional DC-DC converter for high-frequency-link power-conversion system," *IEEE Trans. Power Electron.*, vol. 29, no. 8, pp. 4091–4106, Aug. 2014.
- [281] P. Asfa and J. Bourdon, "Development of a 12kw isolated and bidirectional dc-dc converter dedicated to the more electrical aircraft: The buck boost converter unit (BBCU)," in *Proc. Eur. Int. Exhib. Conf. Power Electron., Intell. Motion, Renewable Energy Energy Manage.*, 2016, pp. 1–8.
- [282] P. Thummala, D. Maksimovic, Z. Zhang and M. A. E. Andersen, "Digital control of a high-voltage (2.5 kV) bidirectional DC-DC flyback converter for driving a capacitive incremental actuator," *IEEE Trans. Power Electron.*, vol. 31, no. 12, pp. 8500–8516, Dec. 2016.
- [283] R. J. Wai and J. J. Liaw, "High-efficiency-isolated single-input multiple-output bidirectional converter," *IEEE Trans. Power Electron.*, vol. 30, no. 9, pp. 4914–4930, Sep. 2015.
- [284] Y. Du, S. Lukic, B. Jacobson, and A. Huang, "Review of high power isolated bi-directional DC-DC converters for PHEV/EV DC charging infrastructure," in *Proc. IEEE Energy Convers. Congr. Expo.*, 2011, pp. 553–560.
- [285] M. Jain, M. Daniele, and P. K. Jain, "A bidirectional DC-DC converter topology for low power application," *IEEE Trans. Power Electron.*, vol. 15, no. 4, pp. 595–606, Jul. 2000.
- [286] L. Roggia, L. Schuch, J. E. Baggio, C. Rech, and J. R. Pinheiro, "Integrated full-bridge-forward DC-DC converter for a residential microgrid application," *IEEE Trans. Power Electron.*, vol. 28, no. 4, pp. 1728–1740, Apr. 2013.
- [287] Y. Xie, J. Sun, and J. S. Freudenberg, "Power flow characterization of a bidirectional galvanically isolated high-power DC/DC converter cover a wide operating range," *IEEE Trans. Power Electron.*, vol. 25, no. 11, pp. 54–66, Jan. 2010.

- [288] R. T. Naayagi, A. J. Forsyth, and R. Shuttleworth, "High-power bidirectional DC-DC converter for aerospace applications," *IEEE Trans. Power Electron.*, vol. 27, no. 11, pp. 4366–4379, Nov. 2012.
- [289] F. Krismer and J. W. Kolar, "Efficiency-optimized high-current dual active bridge converter for automotive applications," *IEEE Trans. Ind. Electron.*, vol. 59, no. 7, pp. 2745–2760, Jul. 2012.
- [290] W. Chen, P. Rong and Z. Lu, "Snubberless bidirectional DC-DC converter with new CLLC resonant tank featuring minimized switching loss," *IEEE Trans. Ind. Electron.*, vol. 57, no. 9, pp. 3075–3086, Sep. 2010.
- [291] Z. Zhang, O. C. Thomsen, M. A. E. Andersen, J. D. Schmidt, and H. R. Nielsen, "Analysis and design of bi-directional DC-DC converter in extended run time DC UPS system based on fuel cell and supercapacitor," in *Proc. IEEE Appl. Power Electron. Conf. Expo.*, 2009, pp. 714–719.
- [292] B. Zhao, Q. Yu, and W. Sun, "Extended-phase-shift control of isolated bidirectional DC-DC converter for power distribution in microgrid," *IEEE Trans. Power Electron.*, vol. 27, no. 11, pp. 4667–4680, Nov. 2012.
- [293] L. Rubino, B. Guida, F. Liccardo, P. Marino, and A. Cavallo, "Buck-boost DC/DC converter for aeronautical applications," in *Proc. IEEE Int. Symp. Ind. Electron.*, 2010, pp. 2690–2695.
- [294] H. J. Chiu and L. W. Lin, "A bidirectional DC-DC converter for fuel cell electric vehicle driving system," *IEEE Trans. Power Electron.*, vol. 21, no. 4, pp. 950–958, Jul. 2006.
- [295] F. Z. Peng, H. Li, G. J. Su, and J. S. Lawler, "A new ZVS bidirectional DC-DC converter for fuel cell and battery application," *IEEE Trans. Power Electron.*, vol. 19, no. 1, pp. 54–65, Jan. 2004.
- [296] G. Ma, W. Qu, G. Yu, Y. Liu, N. Liang, and W. Li, "A zero-voltage-switching bidirectional DC-DC converter with state analysis and soft-switching-oriented design consideration," *IEEE Trans. Ind. Electron.*, vol. 56, no. 6, pp. 2174–2184, Jun. 2009.
- [297] A. K. Rathore, D. R. Patil, and D. Srinivasan, "Non-isolated bidirectional soft-switching current-fed LCL resonant DC/DC converter to interface energy storage in DC microgrid," *IEEE Trans. Ind. Appl.*, vol. 52, no. 2, pp. 1711–1722, Mar./Apr. 2016.
- [298] D. M. Bellur and M. K. Kazmierczuk, "DC-DC converters for electric vehicle applications," in *Proc. Electr. Insul. Conf. Electr. Manuf. Expo.*, 2007, pp. 286–293.
- [299] T. Nagashima, X. Wei, E. Bou, E. Alarcón, M. K. Kazmierczuk, and H. Sekiya, "Analysis and design of loosely inductive coupled wireless power transfer system based on class-E2 DC-DC converter for efficiency enhancement," *IEEE Trans. Circuits Syst. I, Reg. Papers*, vol. 62, no. 11, pp. 2781–2791, Nov. 2015.
- [300] M. Fu, C. Ma, and X. Zhu, "A cascaded boost–buck converter for high-efficiency wireless power transfer systems," *IEEE Trans. Ind. Informat.*, vol. 10, no. 3, pp. 1972–1980, Aug. 2014.
- [301] P. Si, A. P. Hu, J. W. Hsu, M. Chiang, Y. Wang, S. Malpasm, and D. Budgett, "Wireless power supply for implantable biomedical device based on primary input voltage regulation," in *Proc. IEEE 2nd Conf. Ind. Electron. Appl.*, 2007, pp. 235–239.
- [302] F. Mounaim, M. Sawan, and M. El-Gamal, "Fully-integrated inductive power recovery front-end dedicated to implantable devices," in *Proc. IEEE Biomed. Circuits Syst. Conf.*, 2008, pp. 105–108.
- [303] S. Park and T. M. Jahns, "A self-boost charge pump topology for a gate drive high-side power supply," *IEEE Trans. Power Electron.*, vol. 20, no. 2, pp. 300–307, Mar. 2005.
- [304] A. Emadi and M. Ehsani, "Aircraft power systems: technology, state of the art, and future trends," *IEEE Aerosp. Electron. Syst. Mag.*, vol. 15, no. 1, pp. 28–32, Jan. 2000.
- [305] C. Fahrni, A. Rufer, F. Bordry, and J. Burnet, "A novel 60 MW pulsed power system based on capacitive energy storage for particle accelerators," in *Proc. Eur. Conf. Power Electron. Appl.*, 2007, pp. 1–10.
- [306] D. Meike and L. Ribickis, "Energy efficient use of robotics in the automobile industry," in *Proc. 15th Int. Conf. Adv. Robot.*, 2011, pp. 507–511.
- [307] M. Barnes and A. Beddard, "Voltage source converter HVDC links—the state of the art and issues going forward," *Energy Procedia*, vol. 24, pp. 108–122, 2012.
- [308] A. Schon and M. M. Bakran, "High power HVDC-DC converters for the interconnection of HVDC lines with different line topologies," in *Proc. Int. Power Electron. Conf.*, 2014, pp. 3255–3262.
- [309] G. J. Kish, M. Ranjram, and P. W. Lehn, "A modular multilevel DC/DC converter with fault blocking capability for HVDC interconnects," *IEEE Trans. Power Electron.*, vol. 30, no. 1, pp. 148–162, Jan. 2015.



Mojtaba Forouzesh (S'14) received the B.S. degree in physics and the M.S. degree in electrical engineering (with highest honor) from the University of Guilan, Rasht, Iran, in 2011, and 2015, respectively.

He is currently working on several research studies under the support of Aalborg University, Aalborg, Denmark. His research interests include dc–dc power conversion, magnetically coupled impedance source converters, high-efficiency high step-up converters, small-signal modeling of power converters, and digital implementation of modulation and control

schemes.

Mr. Forouzesh is a member of the IEEE Power Electronics Society (PELS) and the IEEE Industrial Electronics Society, and a frequent reviewer for IEEE PELS sponsored conferences and the IEEE TRANSACTIONS ON POWER ELECTRONICS, the *IET Power Electronics*, and the *Wiley International Journal of Circuit Theory and Applications*.



Yam P. Siwakoti (S'10–M'14) received the B.Tech. degree in electrical engineering from the National Institute of Technology, Hamirpur, India, in 2005, the M.E. degree in electrical power engineering (*magna cum laude*) from the Norwegian University of Science and Technology, Trondheim, Norway, and Kathmandu University, Dhulikhel, Nepal, in 2010, and the Ph.D. degree from Macquarie University, Sydney, Australia, in 2014.

In 2014, he joined the Department of Energy Technology, Aalborg University, Denmark, where he was a Postdoctoral Researcher for two years. He is currently a Lecturer/Assistant Professor in the Faculty of Engineering and Information Technology, University of Technology, Sydney, Australia. His research interests include investigating new power converter topology with higher efficiency, reliability, and power density, and application of new widebandgap semiconductor devices (GaN/SiC) for very high frequency power converter and wireless power transfer.

Dr. Siwakoti is an Associate Editor of *IET Power Electronics* and the IEEE INDUSTRIAL ELECTRONICS MAGAZINE. He had served as a Guest Associate Editor for the IEEE TRANSACTIONS ON POWER ELECTRONICS special issue on the impedance source converter topologies and applications. Recently, he has received a prestigious Green Talent Award from the Federal Ministry of Education and Research, Germany.



Saman A. Gorji (S'15) received the B.Sc. and M.Sc. degrees in electrical engineering from University of Guilan, Rasht, Iran, in 2011 and 2013, respectively. He is currently working toward the Ph.D. degree at the School of Software and Electrical Engineering, Swinburne University of Technology, Hawthorn, Australia.

His current research interests include modeling and design of power electronics circuits, efficient power conversion, and renewable electrical energy systems.



Frede Blaabjerg (S'86–M'88–SM'97–F'03) received the Ph.D. degree in electrical engineering from Aalborg University, Aalborg, Denmark, in 1995.

He was with ABB-Scandia, Randers, Denmark, from 1987 to 1988. He became an Assistant Professor in 1992, Associate Professor in 1996, and Full Professor of power electronics and drives in 1998 at Aalborg University. His current research interests include power electronics and its applications such as in wind turbines, photovoltaic systems, reliability engineering, power quality, and adjustable speed drives.

Dr. Blaabjerg has received 18 IEEE Prize Paper Awards, the IEEE PELS Distinguished Service Award in 2009, the EPE-PEMC Council Award in 2010, the IEEE William E. Newell Power Electronics Award 2014, and the Villum Kann Rasmussen Research Award 2014. He was an Editor-in-Chief of the IEEE TRANSACTIONS ON POWER ELECTRONICS from 2006 to 2012. He is nominated in 2014, 2015, and 2016 by Thomson Reuters to be between the most 250 cited researchers in Engineering in the world.



Brad Lehman (M'92–SM'08) received the Ph.D. degree in electrical engineering from Georgia Institute of Technology, Atlanta, GA, USA, in 1992.

He is currently a Professor in the Department of Electrical and Computer Engineering, Northeastern University, Boston, MA, USA. He performs research in solar energy, fault detection, and high-density power converters with applications in solar energy, LED lighting, battery chargers, and telecommunication power supplies.

Dr. Lehman previously chaired the IEEE LED lighting standards group (PAR1789). He is the Editor-in-Chief of the IEEE TRANSACTIONS ON POWER ELECTRONICS and was highlighted in the inaugural edition of the book *The 300 Best Professors* (Framingham, MA, USA: Princeton Review, 2012). He received the 2015 IEEE Power Electronic Society Modeling and Control Technical Achievement Award and a 2015 IEEE Standards Medallion.