



AALBORG UNIVERSITY
DENMARK

Aalborg Universitet

Grid-Friendly High-Reliability Photovoltaic Systems

Sangwongwanich, Ariya

DOI (link to publication from Publisher):
[10.5278/vbn.phd.eng.00048](https://doi.org/10.5278/vbn.phd.eng.00048)

Publication date:
2018

Document Version
Publisher's PDF, also known as Version of record

[Link to publication from Aalborg University](#)

Citation for published version (APA):
Sangwongwanich, A. (2018). *Grid-Friendly High-Reliability Photovoltaic Systems*. Aalborg Universitetsforlag.
<https://doi.org/10.5278/vbn.phd.eng.00048>

General rights

Copyright and moral rights for the publications made accessible in the public portal are retained by the authors and/or other copyright owners and it is a condition of accessing publications that users recognise and abide by the legal requirements associated with these rights.

- Users may download and print one copy of any publication from the public portal for the purpose of private study or research.
- You may not further distribute the material or use it for any profit-making activity or commercial gain
- You may freely distribute the URL identifying the publication in the public portal -

Take down policy

If you believe that this document breaches copyright please contact us at vbn@aub.aau.dk providing details, and we will remove access to the work immediately and investigate your claim.

**GRID-FRIENDLY
HIGH-RELIABILITY PHOTOVOLTAIC
SYSTEMS**

**BY
ARIYA SANGWONGWANICH**

DISSERTATION SUBMITTED 2018



AALBORG UNIVERSITY
DENMARK

Grid-Friendly High-Reliability Photovoltaic Systems

Ph.D. Dissertation
Ariya Sangwongwanich

Dissertation submitted June 18, 2018

Dissertation submitted: June 18, 2018

PhD supervisor: Prof. Frede Blaabjerg
Aalborg University

Assistant PhD supervisors: Assoc. Prof. Yongheng Yang
Aalborg University
Assoc. Prof. Dezso Sera
Aalborg University

PhD committee: Assistant Professor Daniel Ioan Stroe
Aalborg University
Professor Martin Ordonez
UBC
Professor Kai Strunz
Technical University of Berlin

PhD Series: Faculty of Engineering and Science, Aalborg University

Department: Department of Energy Technology

ISSN (online): 2446-1636
ISBN (online): 978-87-7210-215-3

Published by:
Aalborg University Press
Langagervej 2
DK – 9220 Aalborg Ø
Phone: +45 99407140
aauf@forlag.aau.dk
forlag.aau.dk

© Copyright: Ariya Sangwongwanich

Printed in Denmark by Rosendahls, 2018

Abstract

Photovoltaic (PV) systems have much potential to become a major renewable source for clean electricity and they are expected to provide a significant share in the electricity demand in the future. Accordingly, several efforts have been initiated to increase the penetration level of PV systems and introduce more renewables. In order to enable more PV installations, challenging issues in both technical and economic aspects should be properly addressed.

Firstly, seen from the technical perspective, one major concern is related to the integration of the PV systems to the electricity grid. Since the PV power production is strongly dependent on the environmental conditions (e.g., solar irradiance and ambient temperature), the power injected from the PV systems can vary considerably during a day. In the case of wide-scale PV system installations, a considerable amount of fluctuating power will be delivered to the grid which may induce overloading during peak-power generation periods and voltage fluctuations, challenging the system operators. On the other hand, maintaining a high-level of power quality is always mandatory for the future installation of the PV systems. The PV systems have been reported as one source of harmonics including interharmonics delivered to the grid. Thus, solutions to the above challenges are demanded.

Secondly, the cost reduction of PV energy is another important aspect to enable more PV installations. For the application with relatively long expected lifespan such as PV systems (e.g., 20-25 years of operation), the operation and maintenance costs play a major part in the overall cost of energy. According to the field experience, the PV inverter has been reported as one of the most critical components that cause failures in the PV systems. The consequence of the PV inverter failure will not only lead to extra financial and labor efforts to the inverter replacement but also the loss of revenue from the reduced energy yield during the inverter downtime. Therefore, ensuring a highly reliable operation is strongly demanded for the PV inverter, since it has high potential for reducing the cost of PV energy.

To tackle those issues and thus enable more PV systems, this Ph.D. project discusses solutions to improve the control functionality and reliability of power electronics in PV systems. Throughout this project, a flexible power control strategy of PV systems has been developed. A power limiting control strategy has been proposed to limit the maximum feed-in power of the PV system to a certain level. A control solution to limit the ramp-rate of the PV output power is also proposed, namely, a power ramp-rate control strategy. Then, two solutions to realize the power reserve control have also been proposed: 1) Coordinating the control of different PV units with the Constant Power Generation (CPG) control and the Maximum Power Point Tracking (MPPT) operation and 2) Combining the CPG control and the MPPT operation to routinely estimate the available power using only one PV unit. The performance of the proposed control strategies has been validated experimentally under several operating conditions.

Furthermore, the power quality issue of the PV systems, specifically interharmonics is also analyzed in this project. It is confirmed by the experiments that the perturbation of the DC-link voltage during the MPPT operation is one main cause of interharmonics in the grid current. To address this issue, a model to predict interharmonics according to the control parameters has been proposed. The effectiveness of the proposed interharmonic model has been validated. It has been demonstrated that the predicted interharmonics and the experimental measurements are in close agreement.

The reliability of the PV inverter is also analyzed in this project, where the mission profiles of the PV systems are considered. From a reliability point of view, the PV array degradation and oversizing are the two main aspects that can strongly affect the reliability of PV inverters, whose impact has thus been investigated in this project. The results have shown that the PV array degradation can deviate the reliability performance of the PV inverters (i.e., B_{10} lifetime) by more than 50 % compared to the case without considering the degradation. The impact of PV array sizing on the PV inverter reliability has also been analyzed, which shows that the B_{10} lifetime of the PV inverter may decrease by more than 40 % compared to the case without oversizing PV arrays, especially, for the mission profile with low solar irradiance conditions.

Moreover, the solution to the reliability enhancement of PV inverters with the integration of battery systems is also explored in this Ph.D. project. With the integrated battery system, the loading of the PV inverter can be modified in a way to benefit the reliability of the PV inverter. In that case, the damage of the PV inverter can be reduced by 50 % compared to the case without battery systems. Thus, integrating energy storage systems may be a promising solution to enhance the reliability of PV inverters.

Dansk Resumé

Solcelle (PV) systemer har potentiale til at udgøre en anselig vedvarende kilde til produktion af ren elektricitet, og de forventes at bidrage til en betydelig andel af efterspørgslen af elektricitet i fremtiden. Der er derfor igangsat flere bestræbelser for at øge udbredelsen af PV-systemer og indføre flere vedvarende energikilder. For at muliggøre flere PV-installationer, så bør udfordringer vedrørende tekniske og økonomiske aspekter behandles grundigt.

For det første, set fra et teknisk perspektiv, er der en stor bekymring relateret til integrationen af solcelle-systemerne i elnettet. Da energiproduktionen er stærk afhængig af de omgivende forhold (fx solindstråling og temperatur), kan effekten, der leveres af solcelle-systemerne variere betydeligt i løbet af en dag. I tilfælde af at solcelle-systeminstallationer er i stor skala, vil der blive leveret en betydelig mængde varierende effekt til elnettet. Dette kan fremkalde overbelastninger under spidsproduktionsperioder og medføre spændingsudsving, hvilket udfordrer systemoperatørerne af el-nettet. Derudover er det obligatorisk at opretholde en høj strømkvalitet til fremtidige installationer af solcelle-systemer tilsluttet el-nettet. Solcelle-systemerne er allerede blevet rapporteret som årsag til uønskede harmoniske svingninger i elnettet, herunder inter-harmoniske svingninger. Derfor er løsninger på de ovennævnte udfordringer nødvendige.

Et andet vigtigt aspekt for at muliggøre flere PV-installationer er at reducere omkostningerne af solcelle-energien. For en applikation med relativt lang forventet levetid som f.eks. solcelle-systemer (20-25 års drift) spiller drifts- og vedligeholdelsesomkostningerne en stor rolle i den samlede energiomkostning. PV-inverteren er ifølge felt-oplevelser blevet rapporteret, som en af de mest kritiske komponenter, der ofte forårsager fejl i sådanne systemer. Konsekvensen af PV-inverterfejl vil ikke kun medføre en ekstra økonomisk og arbejdsmæssig indsats, men vil også føre til tab af indtægter i den tid inverteren ikke er funktionsdygtig. Derfor kræves der pålidelig drift af solcelle omformeren, da dette har et stort potentiale for at reducere omkostningerne af solcelle-energi.

For at løse disse problemer og dermed muliggøre flere PV-systemer diskuterer denne Ph.D. afhandling mulige løsninger til forbedring af styringsfunktionaliteten og pålideligheden af effektelektronikken i PV-systemer. Igenem dette projektet er der udviklet en fleksibel styringsstrategi for PV-systemer. En effekt-begrænsende kontrolstrategi er blevet foreslået til at begrænse PV-systemets maksimale optagelse effekt til et bestemt niveau. En kontrolløsning til at begrænse raten af PV-udgangseffekten er også foreslået, nemlig en strategi til styring af effekten. Derefter er der også foreslået to løsninger til realisering af effekt-reservekontrol: 1) Koordinering af styringen mellem forskellige solcelle-enheder med styringen af konstant effekt generering (CPG) og maksimal effekt udbytte (MPPT) og 2) Kombination af CPG-styringen og MPPT-operationen til rutinemæssigt at estimere den tilgængelige effekt ved brug af kun en solcelle-enhed. Funktionaliteten af de foreslåede kontrolstrategier er blevet valideret eksperimentelt under flere driftsbetingelser.

I dette projekt analyseres også strøm kvalitetsproblemet af solcelle-systemer, specifikt interharmoniske svingninger. Dette er bekræftet eksperimentielt, at forstyrrelser i DC-spændingen under MPPT-operation er en hovedårsag til interharmoniske svingninger i den strøm der leveres til elnettet. For at løse dette problem er der opstillet en model til forudsigelse af interharmoniske svingninger i henhold til kontrolparametrene brugt i inverteren. Effektiviteten af den foreslåede interharmoniske model er blevet valideret, og det er vist at de varslede interharmoniske svingninger stemmer godt overens med hvad er set i de eksperimentelle målinger.

Pålideligheden af solcelle inverteren er ligeledes analyseret, hvor solcelle-systemernes missions-profiler (belastning) er inkluderet. Ud fra et pålideligheds-synspunkt er nedbrydning og overdimensionering af solcellepaneler de to hovedaspekter, der kan påvirke PV-omformernes pålidelighed. Resultaterne har vist, at nedbrydningen af et solcellepanel kan reducere PV-omformernes pålidelighed med mere end 50 % sammenlignet med det tilfælde, hvor nedbrydning af panelet ikke er inkluderet. Den effekt, som størrelsen af solcellepaneler har på PV inverterens pålidelighed er også blevet analyseret, hvilket viser, at PV-inverterens levetid kan risikere at falde med mere end 40 % i forhold til tilfældet uden at overdimensionere solcellepanelerne, især for en missions-profil med lavt solbestrålingsbetingelser.

Desuden udforskes løsninger på pålidelighedsforøgelse af solcelle inverteren med integrationen af batterisystemer. Med det integrerede batterisystem kan belastningen af solcelle inverteren ændres på en måde, der kan forbedre PV-omformernes pålidelighed. I så fald kan nede-tiden af solcelle-omformeren reduceres med 50 % sammenlignet med tilfældet uden et batteri. Integrerede lagringssystemer kan således være en lovende løsning for at øge PV-omformerens pålidelighed i fremtiden.

Contents

Abstract	iii
Dansk Resumé	v
Thesis Details	ix
Preface	xi
I Report	1
1 Introduction	3
1.1 Background	3
1.1.1 Flexible Power Control in PV Systems	5
1.1.2 Interharmonics from Grid-Connected PV Systems	7
1.1.3 High Reliability of PV Inverters	8
1.2 Project Motivation	10
1.3 Project Objectives and Limitation	11
1.3.1 Research Questions and Objectives	11
1.3.2 Project Limitations	12
1.4 Thesis Outline	13
1.5 List of Publications	14
2 Flexible Power Control of PV Systems	19
2.1 Background	19
2.2 Power Limiting Control Algorithm	20
2.3 Power Ramp-Rate Control Algorithm	21
2.4 Power Reserve Control Algorithm	23
2.4.1 Delta Power Control Strategy for Multi-String Inverters	25

2.4.2	A Sensorless Power Reserve Control Strategy for Two-Stage PV Systems	28
2.5	Summary	32
3	Interharmonics from Grid-Connected PV Systems	35
3.1	Background	35
3.2	Modeling of Interharmonics	36
3.3	Mitigation of Interharmonics	40
3.4	Summary	44
4	Reliability of Power Electronics in PV Systems	49
4.1	Background	49
4.2	Degradation Rates of PV Arrays	52
4.2.1	Thermal Loading	53
4.2.2	Reliability Evaluation	53
4.3	Oversizing of PV Arrays	56
4.3.1	Thermal Loading	57
4.3.2	Reliability Evaluation	57
4.4	Summary	58
5	Enhanced PV Inverter Reliability with Batteries	63
5.1	Background	63
5.2	Reliability Assessment of PV Inverters with Battery Systems	64
5.2.1	Reliability Evaluation	66
5.2.2	Impacts of the Battery System Parameters	68
5.3	Enhanced PV Inverter Reliability with Battery Control	69
5.3.1	Control Strategy of the PV Self-Consumption	69
5.3.2	PV Inverter Loading and Reliability	72
5.4	Summary	74
6	Conclusions	77
6.1	Summary	77
6.2	Main Contributions	79
6.3	Research Perspectives	80
	References	82
	References	82

Thesis Details

Thesis Title: Grid-Friendly High-Reliability Photovoltaic Systems

Ph.D. Student: Ariya Sangwongwanich

Supervisors: Prof. Frede Blaabjerg, Aalborg University
Assoc. Prof. Yongheng Yang, Aalborg University
Assoc. Prof. Dezso Sera, Aalborg University

The main body of this thesis consists of the following papers:

Publications in Refereed Journals

- J1. A. Sangwongwanich, Y. Yang, F. Blaabjerg, and D. Sera, "Delta Power Control Strategy for Multistring Grid-Connected PV Inverters," *IEEE Trans. Ind. App.*, vol. 53, no. 4, pp. 3862-3870, July-Aug. 2017.**
- J2. A. Sangwongwanich, Y. Yang and F. Blaabjerg, "A Sensorless Power Reserve Control Strategy for Two-Stage Grid-Connected PV Systems," *IEEE Trans. Power Electron.*, vol. 32, no. 11, pp. 8559-8569, Nov. 2017.**
- J3. A. Sangwongwanich, Y. Yang, D. Sera, H. Soltani, and F. Blaabjerg, "Analysis and Modeling of Interharmonics from Grid-Connected Photovoltaic Systems," *IEEE Trans. Power Electron.*, vol. PP, no. 99, pp. 1-1.**
- J4. A. Sangwongwanich, Y. Yang, D. Sera, and F. Blaabjerg, "Lifetime Evaluation of Grid-Connected PV Inverters Considering Panel Degradation Rates and Installation Sites," *IEEE Trans. Power Electron.*, vol. 33, no. 2, pp. 1225-1236, Feb. 2018.**

- J5. A. Sangwongwanich**, Y. Yang, D. Sera, F. Blaabjerg, and D. Zhou, "On the Impacts of PV Array Sizing on the Inverter Reliability and Lifetime," *IEEE Trans. Ind. App.*, vol. PP, no. 99, pp. 1–1.
- J6. A. Sangwongwanich**, S. Zurmühlen, G. Angenendt, Y. Yang, D. Sera, D. U. Sauer, and F. Blaabjerg, "Enhancing PV Inverter Reliability with Battery System Control Strategy," *CPSS Trans. Power Electron. App.*, 2018, Status: Under Review.

Publications in Refereed Conferences

- C1. A. Sangwongwanich**, Y. Yang, and F. Blaabjerg, "Development of Flexible Active Power Control Strategies for Grid-Connected Photovoltaic Inverters by Modifying MPPT Algorithms," *Proc. of IFEEC 2017 - ECCE Asia*, Kaohsiung, 2017, pp. 87–92.
- C2. A. Sangwongwanich**, Y. Yang, and F. Blaabjerg, "A Cost-Effective Power Ramp-Rate Control Strategy for Single-Phase Two-Stage Grid-Connected Photovoltaic Systems," *Proc. of ECCE*, Milwaukee, WI, 2016, pp. 1–7.
- C3. A. Sangwongwanich**, Y. Yang, D. Sera, and F. Blaabjerg, "Interharmonics from Grid-Connected PV Systems: Mechanism and Mitigation," *Proc. of IFEEC 2017 - ECCE Asia*, Kaohsiung, 2017, pp. 722–727.
- C4. A. Sangwongwanich**, G. Angenendt, S. Zurmühlen, Y. Yang, D. Sera, D. U. Sauer, and F. Blaabjerg, "Reliability Assessment of PV Inverters with Battery Systems Considering PV Self-Consumption and Battery Sizing," *Proc. of ECCE*, 2018, Status: Accepted.

Co-authored Journal Publications

- O1. Y. Yang**, **A. Sangwongwanich**, and F. Blaabjerg, "Design for Reliability of Power Electronics for Grid-Connected Photovoltaic Systems," *CPSS Trans. Power Electron. App.*, vol. 1, no. 1, pp. 92–103, Dec. 2016.

This dissertation has been submitted for assessment in partial fulfilment of the Ph.D. degree. The thesis is a summary of the outcome from the Ph.D. project, which is documented based on the above publications. Parts of the results are used directly or indirectly in the extended summary of the thesis. The co-author statements have been made available to the assessment committee and are also available at the Faculty of Engineering and Science, Aalborg University.

Preface

The work presented in this dissertation is a summary of the outcome from the Ph.D. project "*Grid-Friendly High-Reliability Photovoltaic Systems*", which was carried out at the Department of Energy Technology, Aalborg University, Denmark. This Ph.D. project is supported by the European Commission within the European Union's Seventh Framework Program (FP7/2007-2013) through the SOLAR-ERA.NET Transnational Project (PV2.3-PV2GRID) and Innovation Fund Denmark through the Advanced Power Electronic Technology and Tools (APETT) project. The author would like to give an acknowledgment to the above-mentioned institutions.

First of all, I would like to extend my deepest gratitude towards my supervisor Professor Frede Blaabjerg for his valuable guidance, kindness, and patience during the study. His support and encouragement are the main drivers for me to complete my Ph.D. study. I would also like to thank my co-supervisors Associate Professor Yongheng Yang and Associate Professor Dezso Sera for their guidance and help during the entire period of the Ph.D. project. It has been such a great experience to work under your supervision.

I am also grateful to Professor Dirk-Uwe Sauer for providing me an opportunity to visit RWTH Aachen University during my study abroad and broaden my knowledge in the area of battery technologies. I would also like to thank my colleagues at ISEA-RWTH Aachen University for their valuable discussion and great hospitality during my stay.

Special thanks go to Associate Professor Huai Wang and Assistant Professor Dao Zhou for their valuable suggestions and help. I would also like to thank all my colleagues and secretaries at the Department of Energy Technology, Aalborg University for their support and fruitful discussion.

Last but not least, I would like to express my gratitude to my family for encouraging me to find my own path in life. Their kindness and encouragement have been (and still be) my greatest support in many ways.

Ariya Sangwongwanich
Aalborg University, June 18, 2018

Part I

Report

Introduction

1.1 Background

Due to the environmental concerns, there is a strong demand to increase the penetration level of renewable energy globally. The Photovoltaic (PV) technology has great potential to become a major renewable source for clean electricity generation in the near future and can provide a significant share in the future electricity demand. In fact, the continuous cost reduction of PV panels and also the Balance-of-System (BOS) components (e.g., wiring and inverters) have made a significant contribution to an increased penetration level of the PV systems in the last decade. Nevertheless, in order to enable more PV installations, several challenges in both technical and economic aspects still need to be addressed for the next-generation PV systems.

A general diagram of grid-connected PV systems is illustrated in Fig. 1.1, which consists of three main parts: PV generator, Power converters, and Distributed grid. From the generator side, the PV panels/arrays are responsible for the power generation, which is achieved by converting the solar energy into the DC electricity. The electrical characteristic and thereby the power production of the PV arrays are strongly dependent on the environmental conditions (e.g., solar irradiance and ambient temperature) of the system. It is demanded that the cost of PV arrays should be further decreased in the near future, in order to increase the cost competitiveness of PV systems [1]. At the same time, the conversion efficiency of the PV arrays is also expected to be improved in order to increase the energy yield and reduce the cost of PV energy. In fact, the long-term performance of the PV system also strongly affects the cost of PV energy. One area that requires further improvement is the degradation rate of PV arrays, as it directly affects the long-term PV energy yield. With the recent technologies, the degradation rate of the PV

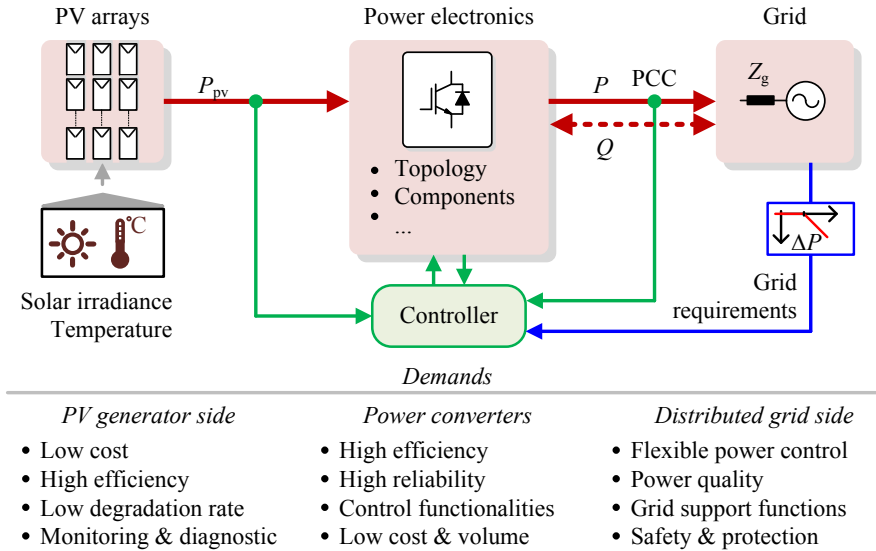

Fig. 1.1: Demands for grid-connected photovoltaic systems (P_{pv} : PV power production, P : Active power delivered to the grid, and Q : Reactive power exchanged with the grid).

arrays is typically 0.8 %/year or less [2]. This corresponds to the lifetime of 25 years, which is a typical warranty provided by the manufacturers [3], where the end-of-life is determined when the PV arrays have degraded to 80 % of their nameplate peak power (i.e., 20 % reduction in the conversion efficiency). However, there is a strong demand to further extend the lifetime of the PV arrays to above 35 years [3]. In that case, the degradation rate of the PV arrays needs to be maintained below 0.5 %/year, which is challenging. Moreover, the PV array degradation rate shows great variation with both panel technology and the climate conditions [2]. This will inevitably affect the loading and thus the reliability performance of PV inverters.

From the distribution grid perspective, the main challenges are related to the integration of the PV systems to the electricity grid. Unlike the conventional power plants (e.g., coal-fired, gas turbine), the PV systems are considered to be non-dispatchable source of electricity. The variability of the PV power generation can impose a challenge on the grid regulation, in the case of high penetration level of PV systems. Thus, it is demanded for the next-generation PV systems to be able to provide power control flexibility, where the PV power production can be flexibly regulated during the operation upon demand [4]. By doing so, the PV systems will be able to support the grid during abnormal events (e.g., fault ride-through, frequency support, and grid voltage support). Moreover, maintaining a high level of power quality is always mandatory for the future installation of the PV systems [5].

1.1. Background

Limiting the harmonic distortion is one of the commonly used power quality measures, as it is well known that the non-ideal switching behavior of the power converters (e.g., PV inverters) in the PV system can induce harmonics in the output current. Recent studies have also reported the incident of inter-harmonic generation of the PV systems, which also needs to be addressed to ensure the power quality and also the stability of the distribution grid.

Acting as an interface between the two ends (i.e., the generator side and the grid side), power converter systems (e.g., PV inverters) based on power electronics play a key role to fulfill the above demands. As part of the power conversion system, high efficiency is required for the power converters in order to increase the overall energy yield. This requirement can be achieved in several ways, e.g., by using new power device technologies (e.g., wide-band gap power devices) [6] or employing multi-level topologies with reduced power losses (e.g., reducing conduction losses with 1500 V DC-link voltage) [7]. From the operation and maintenance perspective, the PV inverters have been reported as one of the weakest components in the PV systems, whose failure can significantly affect the overall power production as well as the maintenance costs. Thus, a highly reliable operation of the power converters (e.g., inverters) is also strongly demanded in order to further reduce the cost of PV energy [8, 9]. Moreover, from the technical perspective, the grid integration challenges also impose a further improvement of the power converters. To fulfill the flexible power control demands, the advanced control functionalities of the PV system needs to be realized through the control of power converters [4]. Similarly, power quality improvement can also be achieved through the power converter control (e.g., harmonics compensations). In all, a grid-friendly integration of the PV system is one of the key requirements of the next-generation PV systems.

1.1.1 Flexible Power Control in PV Systems

Since the electrical characteristic of PV modules/arrays is strongly influenced by the environmental conditions (i.e., solar irradiance and ambient temperature), the power generated by the PV system can vary considerably during the day. As more and more PV systems have been installed and connected to the grid, the variability of the PV power may challenge the grid integration [10, 11]. For instance, overloading of the grid during the PV peak power generation period (e.g., midday) is one of the main concerns under a large PV-installation scenario [12]. Consequences of the overloading include the increase of the power losses, the voltage rise, and the overheating of transformers. Another potential problem caused by PV systems is related to the intermittent nature of PV energy. During cloudy conditions, the power generated by PV systems can fluctuate considerably with a fast change rate. This can potentially cause grid voltage fluctuations, which challenge the voltage

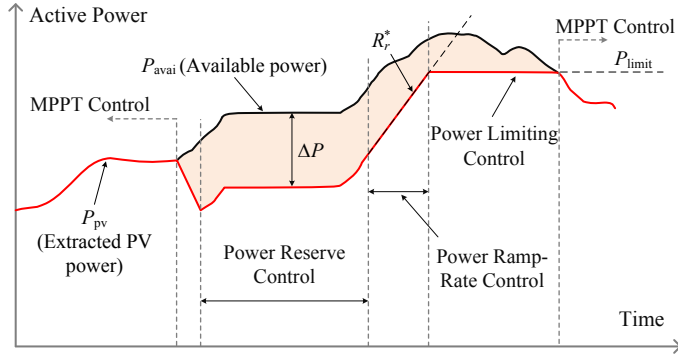

Fig. 1.2: Flexible power control strategies for grid-connected PV systems defined in the Danish grid code (P_{pv} : PV power, P_{avai} : available power, P_{limit} : the power limit level, R_r^* : the ramp-rate limit, ΔP : the power reserve level) [16].

regulation of the network [13], or even the stability of the grid in the case of a large-scale PV system [14]. The frequency regulation capability of the system operators is another concern in the case of a high penetration level of grid-connected PV systems [15]. In that case, the system operators may have a limited capability to stabilize the grid, since the majority of PV systems cannot easily be controlled.

To tackle the above challenges, several grid codes have been recently updated to involve PV systems in the grid regulation [16–21]. In order to achieve so, the next-generation PV systems should be able to regulate the power production following certain constraints to support the grid, instead of always deliver the maximum available power with a Maximum Power Point Tracking (MPPT) operation. Several active power control strategies have been introduced, as shown in Fig. 1.2 and are also described in the following:

- **Power Limiting Control (PLC):** In this operation, the maximum feed-in power of the PV system is limited to a set-point P_{limit} . It can alleviate the overloading issue during the peak power generation period.
- **Power Ramp-Rate Control (PRRC):** This control strategy limits the PV output power change rate to a certain level R_r^* . It is introduced to reduce the fluctuation in the PV power injection.
- **Power Reserve Control (PRC):** The PV system can support the grid by providing a power reserve during the operation. In this case, the extracted PV power is regulated below the available power with an amount of reserved power ΔP .

With the above control strategies, the power generated by the PV system can be flexibly regulated. Thus, the negative impact from the intermittent nature of PV energy can be alleviated to some extent.

1.1. Background

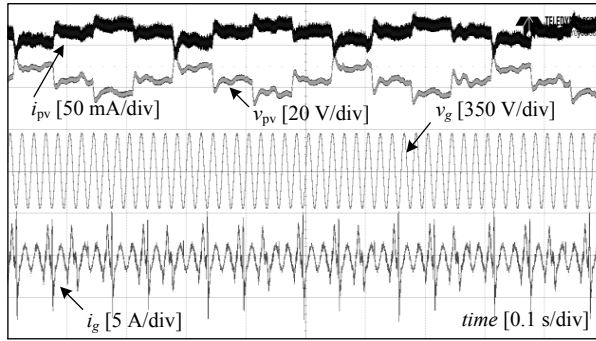

Fig. 1.3: Experimental measurement from a commercial 15-kW PV inverter operating at 2 % of the rated power (i.e., steady-state MPPT operation), where v_{pv} is the PV voltage, i_{pv} is the PV current, v_g is the grid voltage, and i_g is the grid current. Source: [J3].

1.1.2 Interharmonics from Grid-Connected PV Systems

The PV inverters have been reported as one source of harmonics including interharmonics delivered to the grid [22–24]. The generation mechanism of the harmonics in grid-connected PV systems has been investigated, and mitigation solutions have been proposed [25, 26]. In contrast, the interharmonic issues in PV systems are rarely discussed, although it can contribute to flickering and overloading of the grid.

According to the definition, the interharmonics are the frequency components that are non-integer times of the fundamental frequency [27]. In general, the widely acknowledged sources of interharmonic generation are: two asynchronous-conversion systems (e.g., motor drives) [28–30], time-varying loads (e.g., arc furnaces) [31], and mechanical vibrations (e.g., in wind turbines) [32]. Typically, PV systems are not considered as a source of interharmonics, since they are normally viewed as a single DC-AC conversion system. However, it has recently been reported that the PV inverter may contribute to the interharmonics in the grid current, causing power quality problems (e.g., light flickering and overloading) [33–35]. In [34], the interharmonics have been observed in the experimental tests of commercial PV inverters during the steady-state operation. This observation is also confirmed by the experimental test with a commercial PV inverter conducted during the Ph.D. study, where the key experimental waveforms during the steady-state operation are shown in Fig. 1.3. The frequency spectrum of the grid current is shown in Fig. 1.4, indicating that there are interharmonics appearing as a series of low-frequency components. The interharmonic characteristic shown in Fig. 1.4 is to some extent in agreement with the measurement results in some previous studies [33–35].

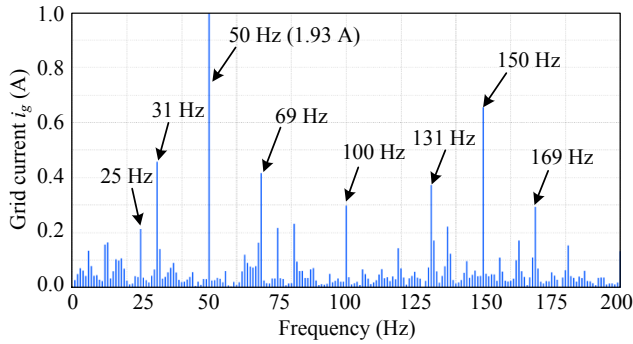

Fig. 1.4: Frequency spectrum of the grid current from the measurements shown in Fig. 1.3 with a frequency resolution of 1 Hz. Source: [J3].

However, the mechanism of the interharmonics in the PV inverter is not yet clearly identified. One hypothesis is that the MPPT operation of the PV inverter imposes the variation in the DC power during the Maximum Power Point (MPP) searching, inducing the interharmonics in the grid current [34]. Nevertheless, it is difficult to obtain the control parameter of commercial PV inverters. Thus, an in-depth analysis to map the control parameters with the interharmonic characteristic is still missing. As a consequence, a modeling approach to identify the interharmonics from the PV inverter as well as their mitigation solutions are not available.

1.1.3 High Reliability of PV Inverters

In addition to the grid integration issues such as flexible power control and interharmonics, reducing the cost of PV energy is another important aspect that is strongly demanded in order to further increase the installation of PV systems [1]. For the application with relatively long expected lifespan such as PV systems (e.g., 20-25 years of operation), the operation and maintenance costs play a major part in the overall cost of energy [36, 37]. According to the field-experience, the PV inverter has been reported as one of the most critical components that causes failures in the PV systems (e.g., 43% - 70% of the total failure events) [8, 9]. Apart from the extra cost due to the inverter replacement, the failure of the PV inverter is also responsible for a significant amount of the energy losses (e.g., up to 36% of the total losses) during the PV inverter downtime [9]. In some cases, the total cost associated with the PV inverter failure can be as high as 59% of the unexpected maintenance cost. Thus, the reliability of the PV inverter is one of the key performances that needs to be ensured in order to lower the cost of PV energy [1].

With an increased demand in the reliability performance of PV inverters, the reliability engineering has been more involved in the design of PV invert-

1.1. Background

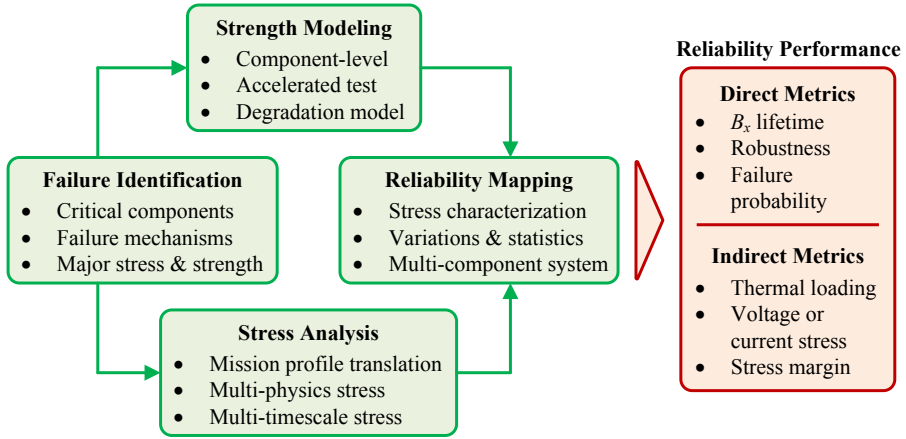

Fig. 1.5: Design for Reliability (DfR) flow diagram for power electronics converters, which can be employed to assess the reliability performance of the designed PV inverter [39].

ers, referred to as a Design for Reliability (DfR) approach [38, 39]. A general diagram of the main tasks in the DfR approach is illustrated in Fig. 1.5, which involves: 1) failure identification, 2) stress analysis and strength modeling, and 3) reliability mapping. At the first stage, the reliability-critical components in the system need to be identified. This can be obtained through either the physics-of-failure analysis or from real-field statistical data. For instance, the power devices and DC-link capacitors are two of the most commonly known critical components in PV inverters [40]. Then, the stress analysis can be analyzed through the loading of the component under a required operating condition, i.e., a mission profile, and the strength of the component can be obtained from the lifetime model. With the stress and strength conditions of the component, the reliability performance of the component can be evaluated. For the system with several components (e.g., PV inverters), a statistical tool to map the component-level reliability performance to the system-level reliability performance such as a reliability block diagram is required [41].

One challenge in the DfR for PV inverters is the uncertainty in the operating condition of the inverter. This can be introduced by the variation in the mission profile of different installation sites. For instance, the PV inverter installed in the hot climate condition (e.g., Arizona) will experience much higher loading during the entire operation compared to the other installation sites with a cold climate condition (e.g., Denmark). This variation is considered to be an important factor that deviates the reliability performance of the designed PV inverter. Further, the uncertainty in the PV inverter reliability can also be introduced by the variation in the PV array characteristic. More specifically, the degradation of the PV arrays normally contributes to

a continuous reduction of the PV output power [2], which affects the loading of the PV inverters. Oversizing the PV arrays is another aspect that may challenge the reliability of the PV inverter due to the increased loading [42]. These aspects should be considered during the design phase in order to address the uncertainty in the reliability evaluation of the designed PV inverter. Moreover, solutions to enhance the reliability of the PV inverter are also demanded, which have not yet been fully explored in the literature. In that regard, the loading of the PV inverter needs to be modified to reduce the component stress. This requirement may be achievable through the integration of the energy storage systems, e.g., batteries. Thus, the impacts of battery system operation on the reliability of PV inverters should also be analyzed, and their potential to enhance the PV inverter reliability needs to be explored.

1.2 Project Motivation

As discussed above, several challenges still need to be addressed in order to increase the penetration level of grid-connected PV systems. From the technical aspects, improving the integration between the PV system and the grid is strongly demanded. This includes the realization of flexible power control functionalities in the PV system as well as ensuring the power quality of the injected current regarding the interharmonics. These demands can be fulfilled by advancing the control of PV inverters, which play the main role in the control of the PV systems. This will allow more PV systems to be integrated into the power grid with a minimum cost requirement.

On the other hand, ensuring a high-reliability operation of the PV system with a minimum downtime count is also of high importance in order to minimize the cost of PV energy (i.e., reduce the unexpected operation and maintenance cost). As one of the most fragile components in the PV system in terms of failure rates, the reliability performance of the PV inverter needs to be evaluated for an intended operating condition (e.g., mission profile), in order to ensure that the reliability target can be fulfilled with the designed inverter. More importantly, the uncertainties in the reliability performance introduced by the mission profile, the PV array degradation, and the PV array sizing also need to be addressed, in order to identify the required design margin in terms of reliability. In addition, the solutions to enhance the reliability performance of the PV inverter should also be explored. In that case, the integration of the energy storage system to the PV system may offer a possibility to modify the loading of the PV inverter in such a way that its reliability performance is improved. The overall research activities in this Ph.D. project are summarized in Fig. 1.6.

1.3. Project Objectives and Limitation

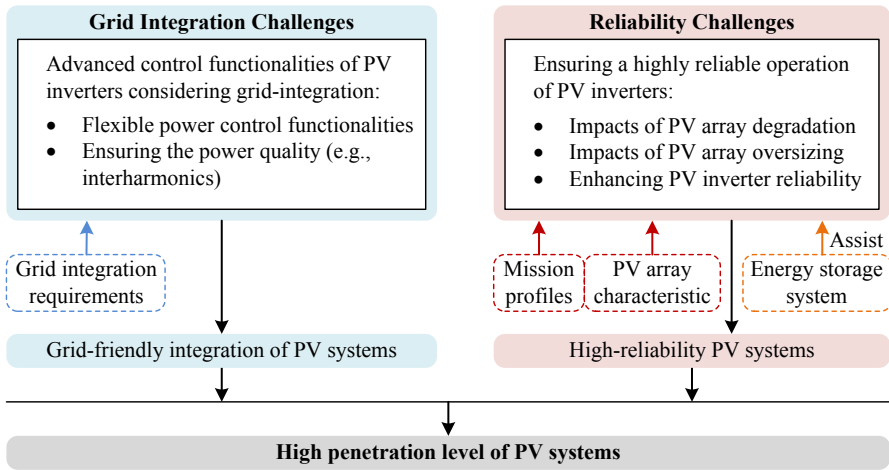

Fig. 1.6: Research activities in the Ph.D. project: Grid-Friendly High-Reliability Photovoltaic Systems.

1.3 Project Objectives and Limitation

1.3.1 Research Questions and Objectives

With the above motivation, the final goal of this Ph.D. project is to enable a high penetration level of PV systems. In order to do so, on one hand, the grid-friendly integration of PV systems needs to be able to solve the technical challenges. On the other hand, the reliability improvement of the PV inverters is also demanded for the reduction in the cost of energy. Accordingly, the following research questions are considered:

- How to enable the flexible power control of grid-connected PV system by advancing the control of PV inverters?
- Is it possible to model the interharmonics from grid-connected PV inverters according to the control parameters?
- How to ensure the reliability performance of the PV inverter under various mission profiles and uncertainties from the PV array characteristic?
- Is it possible to improve the reliability of the PV inverter through the integration of the energy storage systems?

With those research questions, the objectives of the Ph.D. project can be summarized as follows:

Development of flexible power control for grid-connected PV systems

As mentioned previously, the flexible power control of grid-connected PV systems is required in order to avoid the adverse impact from PV systems. In this Ph.D. project, the control strategy to flexibly regulate the output power of the PV systems following the demands in Fig. 1.2 will be developed. The performance of the proposed control strategies will be validated experimentally with a single-phase grid-connected PV system.

Analysis of interharmonics from grid-connected PV inverters

To address the interharmonics from grid-connected PV inverters, an in-depth analysis of the interharmonic generation will be carried out in this Ph.D. project. The expected outcome of the analysis is the modeling approach to predict the interharmonic in the grid current for given controller parameters. Moreover, when the generation mechanism of the interharmonic is understood, the mitigation solutions are also expected to be explored.

Reliability assessment of PV inverters considering mission profiles and PV array characteristics

In order to ensure a highly reliable operation of PV inverters, the reliability assessment based on the DfR approach should be applied to the design of PV inverters. Mission profiles of different installation sites will be considered and their impacts on the reliability performance of the PV inverter will be investigated. The influence of the PV array degradation and oversizing on the PV inverter reliability also needs to be analyzed.

Control solutions to enhance the reliability of PV inverters

Since the PV inverter failure is accounted for a significant lost of revenue, the solution to enhance the reliability of the PV inverter is also demanded. With the knowledge of the main stress factor that causes failure of PV inverters, the control strategy to mitigate/reduce the stress of the PV inverter will be explored. In this aspect, the integration of energy storage system may offer a possibility to modify the loading of the PV inverter in such a way reliability performance is improved.

1.3.2 Project Limitations

There are several PV system configurations adopted in the industry mainly based on the installed power rating. These large variants of system configurations usually lead to different PV inverter topologies, making it difficult to have generalized control strategies and reliability analysis. In this Ph.D. thesis, the main focus is on the single-phase residential PV systems where

1.4. Thesis Outline

the string/multi-string inverter topologies are widely adopted. Regarding the PV inverter topology, the boost converter and the full-bridge inverter are used for the DC-DC and DC-AC conversion stages, respectively.

In the experiments, a PV array simulator is employed to emulate the behavior of the PV arrays. While this representation may not be 100 % realistic compared to the real PV arrays, it is suitable for developing control algorithms, since the test conditions are repeatable. In that case, the performance of different control strategies can be clearly compared.

Regarding the reliability analysis, only the wear-out failure mechanism is considered in this study. That is to say, other failures such as the catastrophic failure, random failure, software failure, human error, etc., are not taken into consideration. Moreover, only the power devices and capacitors are considered in the analysis, since they are reported to be the most reliability-critical components in the PV inverters. The lifetime models of the power devices and capacitors are taken from the available literature and applied to the designed PV inverter. The other components in the system, e.g., fans, connectors, fuses, etc., are not considered in the reliability analysis.

1.4 Thesis Outline

The summary of the outcome of the Ph.D. project is documented in the Ph.D. thesis based on the collection of papers published during the Ph.D. study. The document is structured in two main parts: *Report* and *Selected Publications*. The thesis structure is illustrated in Fig. 1.7, providing a guideline how the content in the *Report* is connected to the *Selected Publications*.

In the *Report*, a brief summary of research conducted during the Ph.D. study is presented, where the main results are based on the *Selected Publications*. The *Report* is organized into six chapters. In *Chapter 1*, the introduction of the Ph.D. thesis is provided, where the background of the research topic and the objective of the Ph.D. study are discussed. Then, the following two chapters deal with the grid-integration challenges in grid-connected PV systems. The main focus of *Chapter 2* is on the flexible power control of PV systems. Various active power control strategies of PV systems are discussed and their control performances are validated with experiments. *Chapter 3* addresses the power quality challenge in grid-connected PV systems, where the interharmonics from PV systems are investigated. The content in this chapter includes the analysis, modeling, and mitigation of the interharmonics from PV systems. The next two chapters deal with the reliability challenges of the inverter in PV systems. In *Chapter 4*, the Design for Reliability (DfR) approach is applied to the design of PV inverters where the mission profile is considered. Further, the uncertainties related to the PV array characteristic are also analyzed. Then, in *Chapter 5*, the possible solutions to enhance the

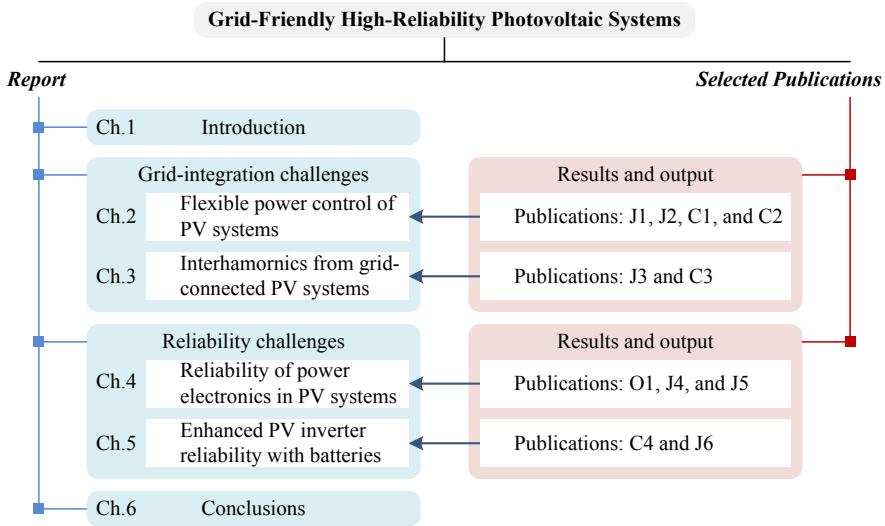

Fig. 1.7: Thesis structure and related topics of each part.

reliability of the PV inverter through the integration of the battery systems are discussed. Finally, concluding remarks and the main contributions in this Ph.D. thesis are summarized in *Chapter 6* and the future research perspectives are outlined.

1.5 List of Publications

The research outcomes during the Ph.D. study have been disseminated in several forms of publications: journal papers, conference publications, book chapters, as listed in the following. Parts of them are used in the Ph.D. thesis as previously listed.

Publications in Refereed Journals

- J1.** A. Sangwongwanich, Y. Yang, F. Blaabjerg, and D. Sera, "Delta Power Control Strategy for Multistring Grid-Connected PV Inverters," *IEEE Trans. Ind. App.*, vol. 53, no. 4, pp. 3862-3870, July-Aug. 2017.
- J2.** A. Sangwongwanich, Y. Yang, and F. Blaabjerg, "A Sensorless Power Reserve Control Strategy for Two-Stage Grid-Connected PV Systems," *IEEE Trans. Power Electron.*, vol. 32, no. 11, pp. 8559-8569, Nov. 2017.
- J3.** A. Sangwongwanich, Y. Yang, D. Sera, H. Soltani, and F. Blaabjerg, "Analysis and Modeling of Interharmonics from Grid-Connected Pho-

1.5. List of Publications

tovoltaic Systems," *IEEE Trans. Power Electron.*, vol. PP, no. 99, pp. 1–1.

- J4. **A. Sangwongwanich**, Y. Yang, D. Sera, and F. Blaabjerg, "Lifetime Evaluation of Grid-Connected PV Inverters Considering Panel Degradation Rates and Installation Sites," *IEEE Trans. Power Electron.*, vol. 33, no. 2, pp. 1225–1236, Feb. 2018.
- J5. **A. Sangwongwanich**, Y. Yang, D. Sera, F. Blaabjerg, and D. Zhou, "On the Impacts of PV Array Sizing on the Inverter Reliability and Lifetime," *IEEE Trans. Ind. App.*, vol. PP, no. 99, pp. 1–1.
- J6. **A. Sangwongwanich**, S. Zurmühlen, G. Angenendt, Y. Yang, D. Sera, D. U. Sauer, and F. Blaabjerg, "Enhancing PV Inverter Reliability with Battery System Control Strategy," *CPSS Trans. Power Electron. App.*, 2018, Status: Under Review.
- O1. Y. Yang, **A. Sangwongwanich**, and F. Blaabjerg, "Design for Reliability of Power Electronics for Grid-Connected Photovoltaic Systems," *CPSS Trans. Power Electron. App.*, Vol. 1, no. 1, pp. 92–103, Dec. 2016.
 - **A. Sangwongwanich**, Y. Yang, F. Blaabjerg, and H. Wang, "Benchmarking of Constant Power Generation Strategies for Single-Phase Grid-Connected Photovoltaic Systems," *IEEE Trans. Ind. App.*, vol. 52, no. 1, pp. 447–457.
 - Y. Yang, E. Koutroulis, **A. Sangwongwanich**, and F. Blaabjerg, "Pursuing Photovoltaic Cost-Effectiveness: Absolute Active Power Control Offers Hope in Single-Phase PV Systems," *IEEE Ind. App. Mag.*, vol. 23, no. 5, pp. 40–49, Sept.–Oct. 2017.

Publications in Refereed Conferences

- C1. **A. Sangwongwanich**, Y. Yang, and F. Blaabjerg, "Development of Flexible Active Power Control Strategies for Grid-Connected Photovoltaic Inverters by Modifying MPPT Algorithms," *Proc. of IFEEC 2017 - ECCE Asia*, Kaohsiung, 2017, pp. 87–92.
- C2. **A. Sangwongwanich**, Y. Yang, and F. Blaabjerg, "A Cost-Effective Power Ramp-Rate Control Strategy for Single-Phase Two-Stage Grid-Connected Photovoltaic Systems," *Proc. of ECCE*, Milwaukee, WI, 2016, pp. 1–7.
- C3. **A. Sangwongwanich**, Y. Yang, D. Sera, and F. Blaabjerg, "Interharmonics from Grid-Connected PV Systems: Mechanism and Mitigation," *Proc. of IFEEC 2017 – ECCE Asia*, Kaohsiung, 2017, pp. 722–727.

- C4. A. Sangwongwanich**, G. Angenendt, S. Zurmühlen, Y. Yang, D. Sera, D. U. Sauer, and F. Blaabjerg, "Reliability Assessment of PV Inverters with Battery Systems Considering PV Self-Consumption and Battery Sizing," *Proc. of ECCE*, 2018, Status: Accepted.
- **A. Sangwongwanich**, Y. Yang, D. Sera, and F. Blaabjerg, "Impacts of PV Array Sizing on PV Inverter Lifetime and Reliability," *Proc. of ECCE*, Cincinnati, OH, 2017, pp. 3830–3837.
 - **A. Sangwongwanich**, Y. Yang, and F. Blaabjerg, "Sensorless Reserved Power Control Strategy for Two-Stage Grid-Connected Photovoltaic Systems," *Proc. of PEDG*, Vancouver, BC, 2016, pp. 1–8.
 - **A. Sangwongwanich**, Y. Yang, F. Blaabjerg, and D. Sera, "Delta Power Control Strategy for Multi-String Grid-Connected PV Inverters," *Proc. of ECCE*, Milwaukee, WI, 2016, pp. 1–7.
 - **A. Sangwongwanich**, Y. Yang, D. Sera, and F. Blaabjerg, "Lifetime Evaluation of PV Inverters Considering Panel Degradation Rates and Installation Sites," *Proc. of APEC*, Tampa, FL, 2017, pp. 2845–2852.
 - **A. Sangwongwanich**, E. Liivik, and F. Blaabjerg, "Photovoltaic Module Characteristic Influence on Reliability of Micro-Inverters," *Proc. of CPE-Powereng*, Doha, Qatar, 2018, pp. 1–6.
 - **A. Sangwongwanich**, Y. Yang, D. Sera, and F. Blaabjerg, "Mission Profile-Oriented Control for Reliability and Lifetime of Photovoltaic Inverters," *Proc. of IPEC*, Niigata, Japan, 2018, pp. 1–7.
 - Y. Yang, **A. Sangwongwanich**, H. Liu, and F. Blaabjerg, "Low Voltage Ride-Through of Two-Stage Grid-Connected Photovoltaic Systems through the Inherent Linear Power-Voltage Characteristic," *Proc. of APEC*, Tampa, FL, 2017, pp. 3582–3588.
 - F. Blaabjerg, D. Zhou, **A. Sangwongwanich**, and H. Wang, "Design for Reliability in Renewable Energy Systems," *Proc. of Ee*, Novi Sad, Serbia, 2017, pp. 1–6.
 - H. D. Tafti, **A. Sangwongwanich**, Y. Yang, G. Konstantinou, J. Pou, and F. Blaabjerg, "A General Algorithm for Flexible Active Power Control of Photovoltaic Systems," *Proc. of APEC*, San Antonio, TX, 2018, pp. 1115–1121.
 - E. Liivik, **A. Sangwongwanich**, and F. Blaabjerg, "Reliability Analysis of Micro-Inverter considering PV Panel Variations and Degradation Rates," *Proc. of EPE'18 ECCE Europe*, Riga, Latvia, 2018, pp. 1–6.

1.5. List of Publications

Book Chapters

- Y. Yang, H. Wang, **A. Sangwongwanich** and F. Blaabjerg, "*Design for Reliability of Power Electronic Systems*," Power Electronics Handbook, 4th ed., Muhammad H. Rashid, Ed.: Elsevier, 2018, ch. 45.
- F. Blaabjerg, **A. Sangwongwanich** and Y. Yang, "*Flexible Power Control of Photovoltaic Systems*," in Advances in Renewable Energies and Power Technologies, 1st ed., Imene Yahyaoui, Ed.: Elsevier, 2018, ch. 6.
- **A. Sangwongwanich**, A. Abdelhakim, Y. Yang and K. Zhou, "*Control of Single-Phase and Three-Phase DC/AC Converters*," in Control of Power Electronic Converters and Systems, 1st ed., Frede Blaabjerg, Ed.: Elsevier, 2018, ch. 6.

Flexible Power Control of PV Systems

2.1 Background

As a key enabling technology to control the power extraction from PV systems, power electronic systems play an important role in realizing the flexible power control [43, 44]. Conventionally, an MPPT algorithm is implemented in the power converter to maximize the PV energy yield during the operation. However, the PV power production with the MPPT operation can fluctuate considerably due to the dynamic of the environmental conditions. In order to realize a flexible power control of PV systems, the MPPT algorithm needs to be modified according to the active power control requirement. More specifically, the PV power extraction from the PV arrays needs to be reduced below the maximum available power to certain levels in order to fulfill the active power control demand, as it is illustrated in Fig. 2.1. This can be achieved by regulating the operating point in the power-voltage curve of the PV array be-

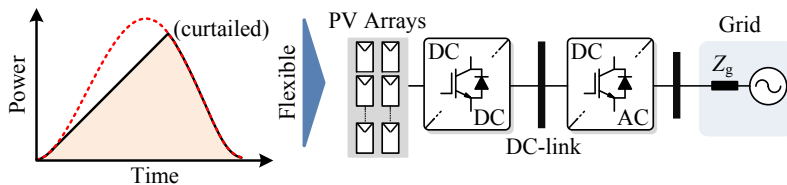

Fig. 2.1: Flexible active power control for grid-connected PV systems by modifying the control algorithm of the power converters. Source: [C1].

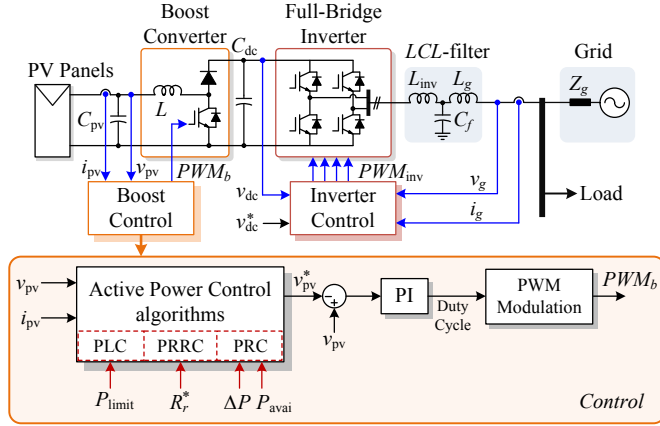

Fig. 2.2: Circuit diagram and control structure of a two-stage grid-connected PV system with active power control strategies (PLC: Power Limiting Control, PRRC: Power Ramp-Rate Control, PRC: Power Reserve Control). Source: [C1].

low the Maximum Power Point (MPP) during the operation. This operation is also called the power curtailment in the literature.

Following the above discussion, the flexible power control solution based on modifying the control algorithm of the power converters will be discussed in this chapter. The two-stage grid-connected PV system shown in Fig. 2.2 is considered in the implementation. In this configuration, the boost converter (i.e., DC–DC converter) is responsible for the PV power extraction (e.g., active power control) while the full-bridge inverter (e.g., DC–AC converter) is employed to convert the extracted DC power into the AC power delivered to the grid [45, 46]. The control of PV power extraction is achieved through the regulation of the PV array voltage v_{pv} at the DC–DC conversion stage, where the reference PV voltage, v_{pv}^* , is determined by the active power control algorithm. In the following, the control algorithm to realize the active power control strategy: Power Limiting Control (PLC), Power Ramp-Rate Control (PRRC), and Power Reserve Control (PRC) will be discussed, and the control performance will be demonstrated experimentally with a 3-kW single-phase PV system test bench.

2.2 Power Limiting Control Algorithm

The control objective of the PLC strategy is to limit the maximum feed-in power of the PV system to a certain level P_{limit} . This operating condition can be inherently fulfilled with the MPPT operation when the available PV power is below the power-limit level: $P_{pv} \leq P_{limit}$, e.g., during the early morning.

2.3. Power Ramp-Rate Control Algorithm

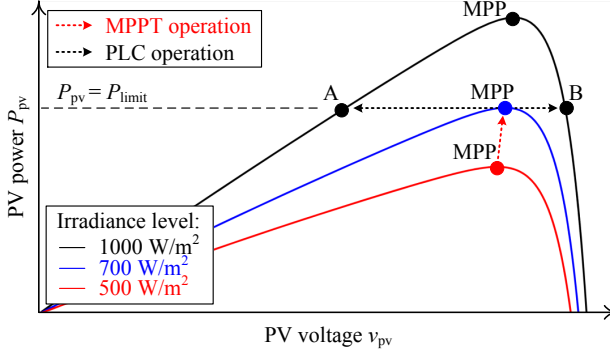

Fig. 2.3: Operational principle of the Power Limiting Control (PLC) algorithm, where the operating point of the PV array is regulated below the Maximum Power Point (MPP), i.e., at A or B, during the PLC operation. Source: [C1].

However, once the available PV power exceeds the power limit: $P_{pv} > P_{limit}$, e.g., during the midday, the operating point of the PV arrays needs to be moved away from the MPP in order to reduce the extracted PV power to the required power-limit level. The PLC strategy for grid-connected PV system has been proposed in [C1], whose operational principle is shown in Fig. 2.3. The reference PV voltage during the PLC operation can be summarized as

$$v_{pv}^* = \begin{cases} v_{MPPT}, & \text{when } P_{pv} \leq P_{limit} \\ v_{pv} - v_{step}, & \text{when } P_{pv} > P_{limit} \end{cases} \quad (2.1)$$

where v_{MPPT} is the reference voltage from the MPPT algorithm (i.e., Perturb and Observe MPPT) and v_{step} is the perturbation step size.

An experimental demonstration of the PLC strategy is shown in Fig. 2.4, where two operating conditions during a clear day (e.g., smooth solar irradiance condition) and a cloudy day (e.g., fluctuating solar irradiance condition) are considered. In both cases, the maximum feed-in power of the PV system can be limited according to the set-point of $P_{limit} = 1.5$ kW, validating the effectiveness of the proposed PLC strategy.

2.3 Power Ramp-Rate Control Algorithm

In the case of the PRRC strategy, the main control objective is to limit the change rate of the PV output power to a certain level R_r^* , as it has been shown previously in Fig. 1.2. Therefore, the PV power ramp-rate $R_r(t)$ (i.e., the change rate of the PV output power) needs to be monitored during the operation, which can be calculated as

$$R_r(t) = \frac{dP_{pv}}{dt} \quad (2.2)$$

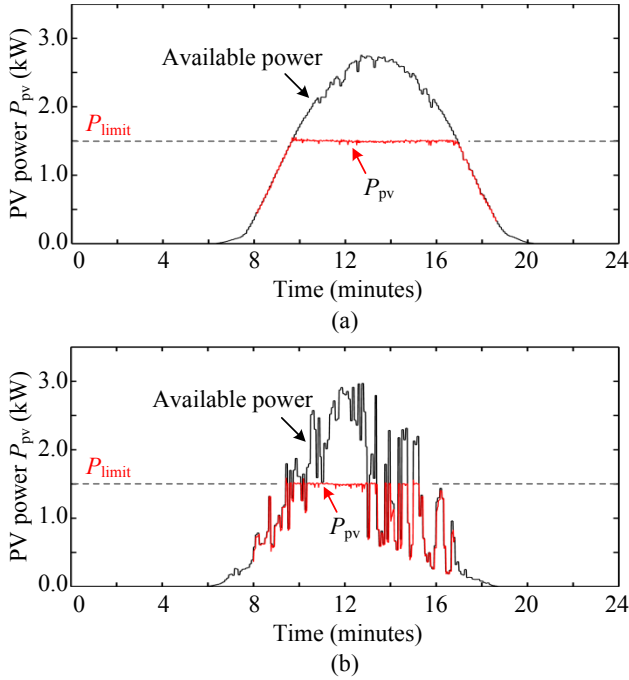

Fig. 2.4: PV output power P_{pv} during the power limiting control with the power-limit level of $P_{limit} = 1.5$ kW under: (a) a clear-day and (b) a cloudy-day conditions (with an accelerated test in time scale to reduce the testing time from 24 h to 24 min). Source: [C1].

Then, the measured ramp-rate $R_r(t)$ is compared with the set-point R_r^* to determine the power curtailment criterion, as it is proposed in [C2]. More specifically, as long as the ramp-rate is below the set-point (i.e., $R_r(t) \leq R_r^*$), the PV system is allowed to operate with the MPPT operation, since the PRRC constraint is fulfilled. However, once the measured ramp-rate exceeds the maximum limit (i.e., $R_r(t) > R_r^*$), the operating point of the PV arrays needs to be perturbed away from the MPP in order to reduce the PV power change rate to the required value (i.e., $R_r(t) = R_r^*$), as it is shown in Fig. 2.5. The reference PV voltage with the PRRC strategy can be summarized as

$$v_{pv}^* = \begin{cases} v_{MPPT}, & \text{when } R_r(t) \leq R_r^* \\ v_{pv} - v_{step}, & \text{when } R_r(t) > R_r^* \end{cases} \quad (2.3)$$

The performance of the PV system with the PRRC strategy is validated experimentally, where the PV output power and the corresponding ramp-rate during the clear-day and cloudy-day operating conditions are shown in Figs. 2.6(a) and 2.6(b), respectively. In both cases, the ramp-rate limit of R_r^*

2.4. Power Reserve Control Algorithm

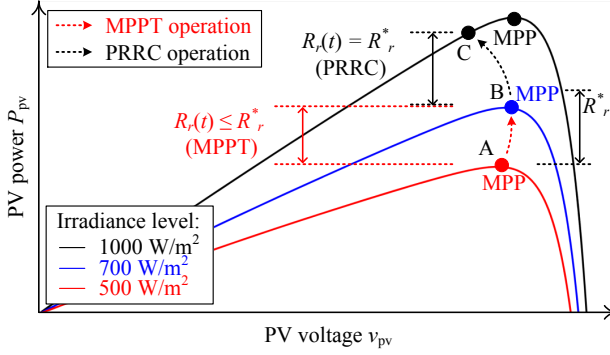

Fig. 2.5: Operational principle of the Power Ramp-Rate Control (PRRC) algorithm: the operating point of the PV array is regulated below the Maximum Power Point (MPP) during the PRRC operation (i.e., $B \rightarrow C$). Source: [C2].

$= 10 \text{ W/s}$ is used to demonstrate the controllability of the proposed PRRC strategy. It can be seen from the results in Fig. 2.6 that the PV output power changes with a ramp manner following the PRRC constraint. As a result, the measured ramp-rate during the operation is kept below the maximum limit during most of the time. Notably, there is a short time period where the measured ramp-rate exceeds the set-point due to the fast transient in the solar irradiance condition. In that case, the PRRC strategy requires a number of iterations to reach the required operating point (i.e., $R_r(t) = R_r^*$). Nevertheless, the above results have validated that the PRRC strategy can limit the change rate in the PV power according to the demand.

2.4 Power Reserve Control Algorithm

The purpose of the PRC strategy is to maintain a power difference between the available PV power P_{avai} and the PV output power P_{pv} with the amount corresponding to the power reserve level ΔP , which can be calculated as

$$\Delta P = P_{\text{avai}} - P_{\text{pv}} \quad (2.4)$$

In order to do so, the PV output power needs to follow the dynamics of the available PV power (while maintaining the power difference of ΔP). Actually, the PRC strategy can be viewed as a special case of the PLC operation, where the power-limit level changes dynamically during the operation as: $P_{\text{limit}} = P_{\text{avai}} - \Delta P$. The operational principle of the PRC strategy is shown in Fig. 2.7 and the reference PV voltage can be summarized as in the following

$$v_{\text{pv}}^* = \begin{cases} v_{\text{MPPT}}, & \text{when } P_{\text{pv}} \leq P_{\text{avai}} - \Delta P \\ v_{\text{pv}} - v_{\text{step}}, & \text{when } P_{\text{pv}} > P_{\text{avai}} - \Delta P \end{cases} \quad (2.5)$$

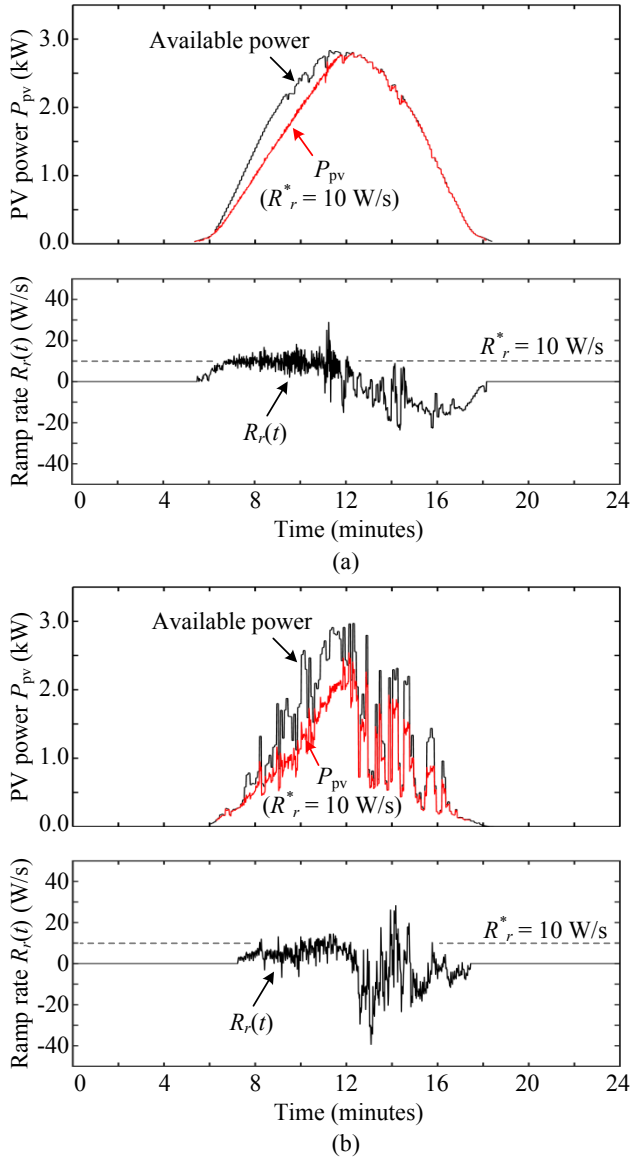

Fig. 2.6: PV output power P_{pv} and the measured power ramp-rate $R_r(t)$ during the power ramp-rate control with the ramp-rate limit of $R_r^* = 10$ W/s under: (a) a clear-day and (b) a cloudy-day conditions (with an accelerated test in time scale to reduce the testing time from 24 h to 24 min). Source: [C2].

2.4. Power Reserve Control Algorithm

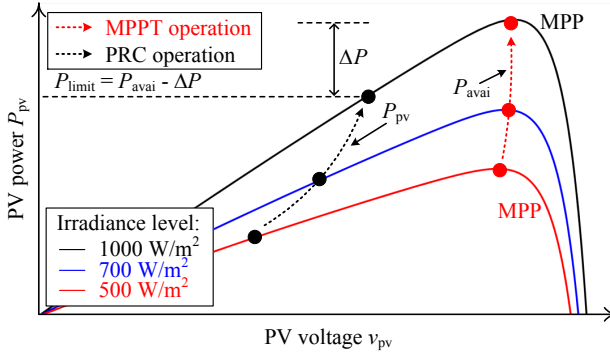

Fig. 2.7: Operational principle of the Power Reserve Control (PRC) algorithm: the operating point of the PV array is regulated below the Maximum Power Point (MPP) with the amount of power reserve level ΔP . Source: [J1].

In this case, the main challenge is the estimation of the available PV power, which is required for determining the power-limit level P_{limit} during the operation for a given amount of power reserve ΔP (i.e., $P_{\text{limit}} = P_{\text{avai}} - \Delta P$). Several methods to estimate the available PV power during the operation have been proposed in the literature using: 1) solar irradiance measurement (and PV array characteristic model) [47, 48], 2) curve-fitting approximation [49–51], and 3) weather forecast data [52]. Nevertheless, these solutions have a certain limitation in terms of cost, complexity, and accuracy. More importantly, they are sensitive to parameter variations, e.g., due to the aging of PV panels and manufacturing tolerance, which can occur during the entire lifespan of the PV system. Accordingly, two solutions to estimate the available PV power during the operation with the application of the PRC strategy have been proposed in this Ph.D. project.

2.4.1 Delta Power Control Strategy for Multi-String Inverters

As discussed previously, the PRC strategy requires two control objectives: 1) the estimation of the available PV power and 2) the regulation of PV output power (e.g., PLC operation). These demands can be achieved by having two different units in the system for each control functionality. Actually, this is applicable for the multi-string PV inverter topology shown in Fig. 2.8, which is a commonly used topology in residential/commercial PV systems. In this configuration, each PV string is equipped with a DC-DC converter (e.g., boost converter), which is controlled independently to perform the PV power extraction control (e.g., MPPT control), offering a possibility to implement different control functionalities, as it is shown in Fig. 2.9.

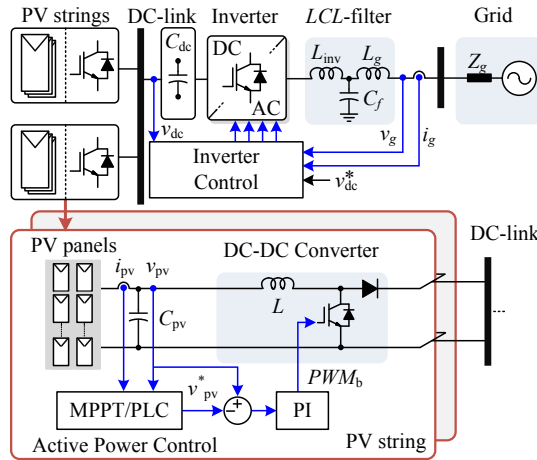

Fig. 2.8: System configuration and control structure of multi-string PV inverters (MPPT: Maximum Power Point Tracking, PLC: Power Limiting Control). Source: [J1].

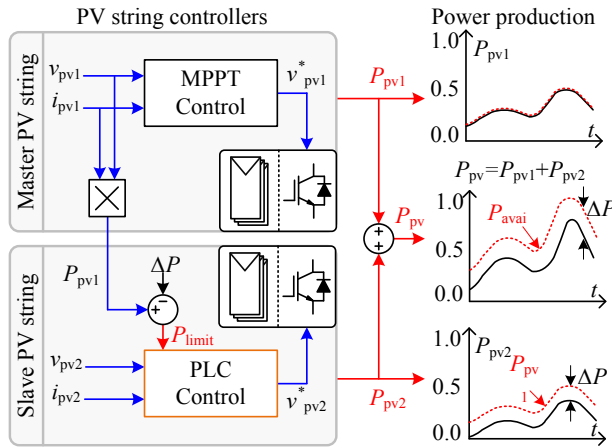

Fig. 2.9: Delta Power Control strategy for multi-string PV inverters with a coordinated control between the master PV strings, i.e., Maximum Power Point Tracking (MPPT) operation, and the slave PV strings, i.e., Power Limiting Control (PLC) operation. Source: [J1].

In order to realize the PRC strategy, the so-called Delta Power Control (DPC) strategy has been proposed in [J1], where one (or more) PV string is assigned to operate as a master unit with the MPPT operation and extract the maximum available power of its unit. Then, with the ratio between the rated power of the total PV system and the rated power of the master string, the total available PV power of the entire system can be estimated during the operation. Notably, this operation is based on the assumption that most

2.4. Power Reserve Control Algorithm

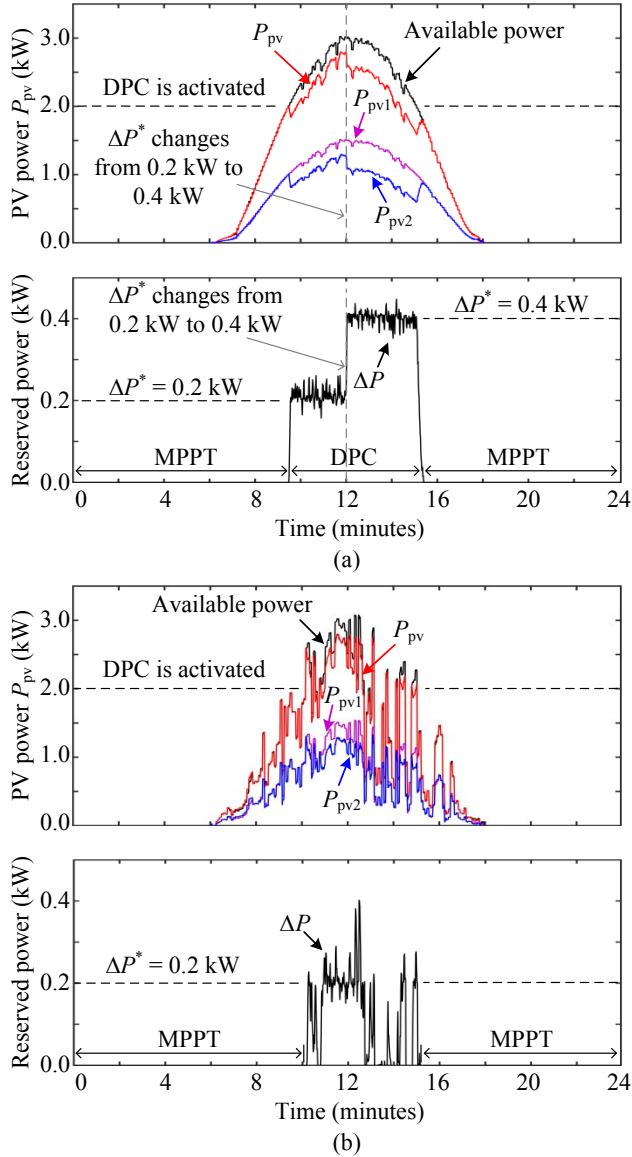

Fig. 2.10: PV output power and the power reserve ΔP with the Delta Power Control (DPC) strategy under: (a) a clear-day and (b) a cloudy-day conditions (with an accelerated test in time scale to reduce the testing time from 24 h to 24 min), where P_{pv} is the total PV output power, P_{avai} is the estimated available power, and P_{pv1} and P_{pv2} are the output power of the master and slave strings, respectively. Source: [J1]

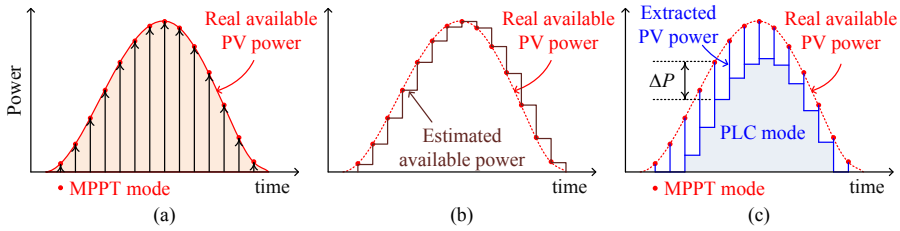

Fig. 2.11: Operational principle of the available power estimation: (a) MPPT mode is routinely employed, (b) the estimated available power during the MPPT mode, and (c) the PV power extraction with a combined MPPT and PLC operation. Source: [J2].

PV strings are located close to each other (e.g., installed under the same rooftop) and thus being exposed to similar environmental conditions. Once the available power is estimated, the other PV strings are assigned to operate with the PLC strategy to realize the PRC strategy, as it is shown in Fig. 2.9.

The performance of the DPC strategy is demonstrated in Fig. 2.10, where two operating conditions during a clear day and a cloudy day are considered. During the test, the DPC strategy is activated when the available power of the PV system exceeds 2 kW. In Fig. 2.10(a), the PV system is operated under the slow changing irradiance condition and the power reserve reference ΔP changes from 200 W to 400 W at $t = 12$ minutes. It can be seen from the results that the power reserve level can follow its reference value during the operation. Moreover, the PRC operation can also be maintained under a fluctuating solar irradiance condition, as it is shown in Fig. 2.10(b). In this case, the power reserve can be kept at its reference value $\Delta P = 200$ W. A small violation only occurs during $t = 10 - 13$ minutes, where the accuracy of the estimated available power is reduced due to a sudden change in the solar irradiance condition. In that case, the MPPT operation has not yet reached the MPP, and thus it introduces a small error in the PRC operation.

2.4.2 A Sensorless Power Reserve Control Strategy for Two-Stage PV Systems

In contrast to the DPC strategy, a solution to combine both MPPT and PLC operations in one PV unit (e.g., one PV string) has been proposed in [J2]. In this case, the MPPT operation is routinely employed to measure (or estimate) the available PV power regularly. Once the available PV power is estimated, the PLC is then employed to limit the extracted PV power according to the PRC requirement. The operational principle of the available PV power estimation is illustrated in Fig. 2.11. Due to the combination of the MPPT and PLC operations, the peak PV power is extracted from the PV array during the available PV power estimation process (e.g., MPPT mode), as it can be seen in

2.4. Power Reserve Control Algorithm

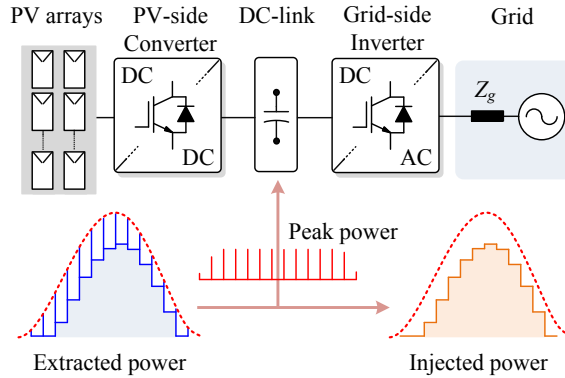

Fig. 2.12: Operational principle of the Sensorless Power Reserve Control (SPRC) strategy, where the peak power is stored in the DC-link during the MPPT mode. Source: [J2].

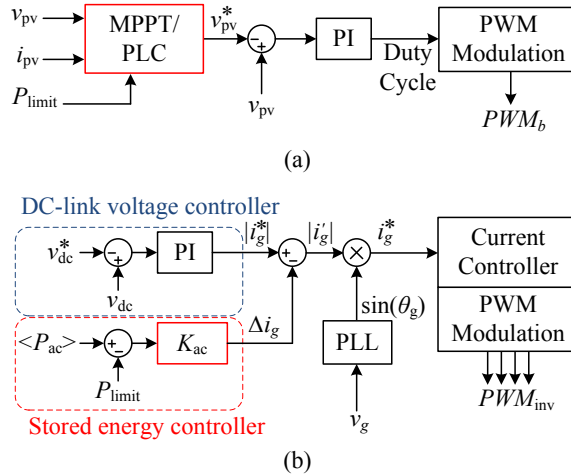

Fig. 2.13: Control structure of the Sensorless Power Reserve Control (SPRC) strategy: (a) the DC-DC converter with Maximum Power Point Tracking (MPPT) and Power Limiting Control (PLC) operation and (b) the DC-AC inverter with the stored energy controller. Source: [J2].

Fig. 2.11(c). To ensure that the PRC constraint is always maintained during the operation, the peak PV power during the MPPT mode is not allowed to pass to the AC grid. In the proposed control strategy, the DC-link voltage is temporarily increased during the MPPT mode to store the excess energy during the peak power injection in the DC-link. The concept of the Sensorless Power Reserve Control (SPRC) strategy is shown in Fig. 2.12, and the control structure of the PV-side DC-DC converter and the grid-side DC-AC inverter is shown in Figs. 2.13(a) and 2.13(b), respectively.

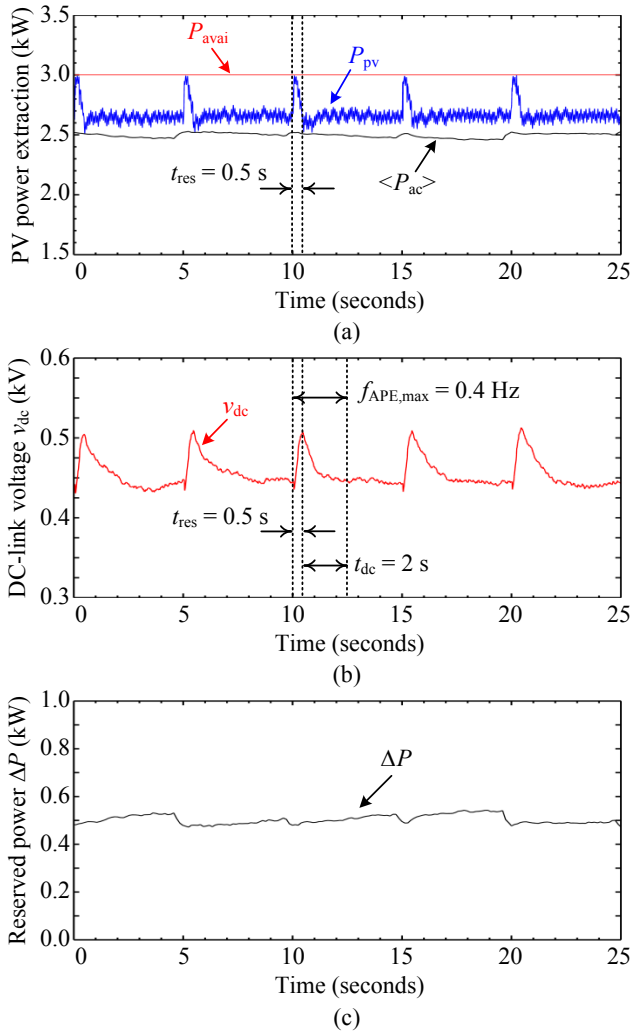

Fig. 2.14: Experimental results of the Sensorless Power Reserve Control (SPRC) strategy under a constant solar irradiance condition with the reference power reserve level of 500 W: (a) PV power P_{pv} , AC power P_{ac} , and available power P_{avai} , (b) DC-link voltage v_{dc} , and (c) power reserve ΔP . Source: [J2].

The performance of the SPRC during the steady-state operation (i.e., constant solar irradiance condition) is demonstrated in Fig. 2.14, where the reference power reserve is 500 W. The combination of the MPPT and CPG operations can be seen from the extracted PV power in Fig. 2.14(a), where the PV power is regulated at the MPP (e.g., 3 kW) to estimate the available PV power regularly (i.e., every 5 seconds). During the MPPT mode, the DC-link voltage

2.4. Power Reserve Control Algorithm

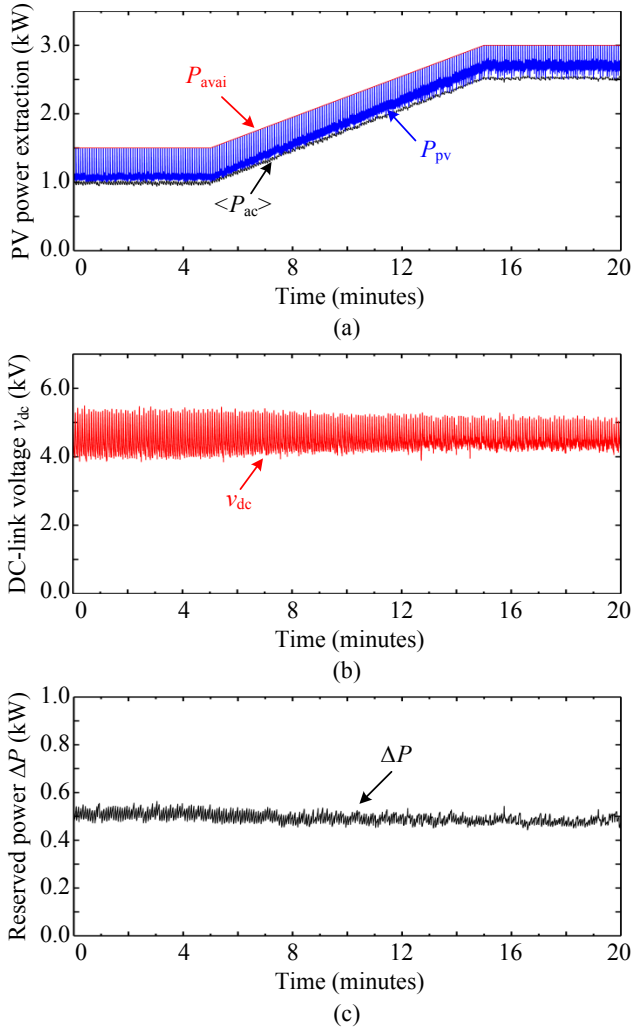

Fig. 2.15: Experimental results of the Sensorless Power Reserve Control (SPRC) strategy under a changing solar irradiance condition with the reference power reserve level of 500 W: (a) PV power P_{pv} , AC power P_{ac} , and available power P_{avai} , (b) DC-link voltage v_{dc} , and (c) power reserve ΔP . Source: [J2].

shown in Fig. 2.14(b) is temporarily increased to store the peak power injection in the DC-link. Consequently, the AC power injected to the grid $\langle P_{ac} \rangle$ in Fig. 2.14(a) can be maintained at $\langle P_{ac} \rangle = 2.5$ kW during the entire operation, following the PRC requirement with the power reserve level of $\Delta P = 500$ W, as it is shown in Fig. 2.14(c). The performance of the SPRC strategy during a ramp-changing solar irradiance condition is also investigated in Fig. 2.15.

In this case, the dynamic performance of the SPRC strategy is challenged by the changing available power during the operation. It can be seen from the results in Fig. 2.15(a) that the available PV power is periodically measured, and the injected AC power (P_{ac}) can follow the change in the available PV power while maintaining the power reserve of 500 W during the operation, as it is shown in Fig. 2.15(c). Accordingly, the PRC strategy can be realized without the need of solar irradiance sensors or extra measurements.

2.5 Summary

In this chapter, the flexible power control of PV systems have been discussed. A power limiting control strategy has been proposed to limit the maximum feed-in power of the PV system to a certain level. This is achieved by moving the operating point of the PV system away from the MPP once the PV output power exceeds the power-limit level. Similar control strategy can also be applied to realize the power ramp-rate control of the PV system, where the MPPT algorithm is modified to reduce the PV output power once the measured ramp-rate of the PV power exceeds the maximum limit. Two control solutions to realize the power reserve control of PV systems have also been proposed. The first control strategy utilizes the multi-string PV inverter topology, where part of the PV strings perform the available power estimation while the rest of the PV strings are coordinately controlled to regulate the total output power following the power reserve requirement. An alternative solution to combine both the available power estimation and the PV power regulation has also been discussed, where the peak PV power during the available power estimation is stored in the DC-link. The performance of the proposed control strategies has been validated experimentally.

Related Publications

- C1. A. Sangwongwanich**, Y. Yang, and F. Blaabjerg, "Development of Flexible Active Power Control Strategies for Grid-Connected Photovoltaic Inverters by Modifying MPPT Algorithms," *Proc. of IFEEC 2017 - ECCE Asia*, Kaohsiung, 2017, pp. 87–92.

Main contribution:

An overview of the flexible active power control for grid-connected PV systems is discussed in this paper. The PLC strategy is proposed and validated experimentally.

- C2. A. Sangwongwanich**, Y. Yang, and F. Blaabjerg, "A Cost-Effective Power Ramp-Rate Control Strategy for Single-Phase Two-Stage Grid-Connected Photovoltaic Systems," *Proc. of ECCE*, Milwaukee, WI, 2016, pp. 1–7.

2.5. Summary

Main contribution:

In this paper, the concept of PRRC strategy is proposed and validated experimentally.

- J1. A. Sangwongwanich, Y. Yang, F. Blaabjerg, and D. Sera, "Delta Power Control Strategy for Multistring Grid-Connected PV Inverters," *IEEE Trans. Ind. App.*, vol. 53, no. 4, pp. 3862-3870, July-Aug. 2017.**

Main contribution:

The PRC operation based on the Delta Power Control strategy is proposed in this paper. The operational principle, design guideline, and performance validation of the control strategy are discussed.

- J2. A. Sangwongwanich, Y. Yang, and F. Blaabjerg, "A Sensorless Power Reserve Control Strategy for Two-Stage Grid-Connected PV Systems," *IEEE Trans. Power Electron.*, vol. 32, no. 11, pp. 8559-8569, Nov. 2017.**

Main contribution:

The idea of the sensorless power reserve control strategy is proposed in this paper. The design consideration and performance validation of the proposed control strategy are discussed and validated experimentally.

Interharmonics from Grid-Connected PV Systems

3.1 Background

According to previous studies, the MPPT operation of the PV inverter is suspected to be one of interharmonics sources in the output current [33–35]. In order to verify this hypothesis, experiments during the MPPT operation are carried out with the single-phase grid-connected PV system, whose system diagram is shown in Fig. 3.1. The Perturb and Observe (P&O) MPPT algorithm is employed to determine the reference DC-link voltage of the PV inverter (e.g., the PV array voltage). The control structure of the PV inverter is shown in Fig. 3.2. The experimental results during the steady-state MPPT operation of the PV inverter are demonstrated in Fig. 3.3. In this case, the perturbation frequency of the MPPT algorithm is $f_{MPPT} = 5$ Hz. The operating point of the PV arrays (e.g., the PV array voltage) oscillates between

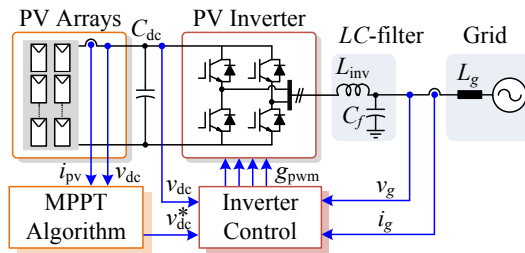

Fig. 3.1: System diagram of single-phase grid-connected PV system under test. Source: [J3].

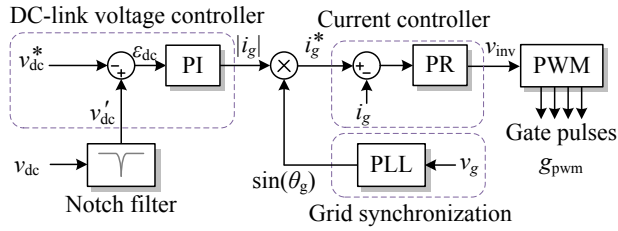

Fig. 3.2: Control structure of single-phase PV inverter under test. Source: [J3].

three points (due to the MPP searching) with the frequency corresponding to the perturbation frequency (i.e., MPPT sampling rate). As a consequence, the output current injected to the grid is distorted periodically due to the steady-state oscillation of the MPPT operation. When analyzing the frequency spectrum of the grid current, there are interharmonics in the grid current, which appear as a series of frequency component with a constant distance between the two consecutive components, as it is shown in Fig. 3.3(d). This characteristic is resemble with the experimental measurement from the commercial PV inverter in Fig. 1.4, where the envelope of the interharmonic frequencies is symmetrical and the interharmonics are concentrated around the fundamental frequency component of the grid current.

3.2 Modeling of Interharmonics

The experimental results in Fig. 3.3 confirm that the MPPT operation is a root-cause of interharmonics in the grid current. In order to map the characteristics of interharmonics (e.g., frequency and amplitude) to the control parameters, the analysis and modeling of interharmonics with respect to the control parameters have been carried out in [J3].

The modeling approach proposed in [J3] is illustrated in Fig. 3.4, which involves three main modeling steps: 1) Periodic MPPT oscillation, 2) Response of the DC-link voltage perturbation, and 3) Amplitude modulation.

- Periodic MPPT Oscillation:** As the main cause of interharmonic, a representation of the DC-link voltage during the MPPT perturbation in the frequency domain is required for the analysis. Thus, the Fourier analysis needs to be applied to the time-domain waveform of the reference DC-link voltage during the MPPT oscillation (e.g., Fig. 3.3(a)), in order to decompose the reference DC-link voltage into a set of frequency components. Notably, the information of the perturbation step-size and the MPPT sampling rate in the time-domain waveform of the DC-link voltage will be represented in the frequency-domain after applying the Fourier analysis. Thus, the impact of control parameters (e.g., MPPT

3.2. Modeling of Interharmonics

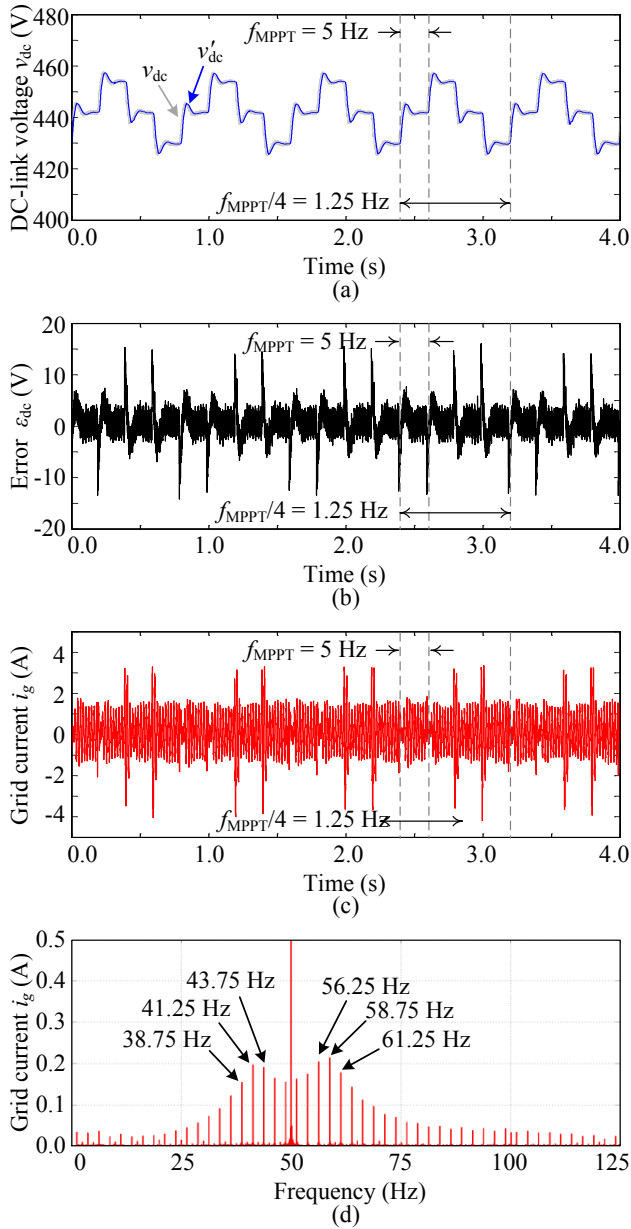

Fig. 3.3: Experimental results of the PV inverter during the steady-state MPPT operation: (a) the measured DC-link voltage v_{dc} and its DC component v'_{dc} , (b) error in the DC-link voltage ϵ_{dc} , (c) grid current i_g , and (d) frequency spectrum of the grid current i_g . Source: [J3].

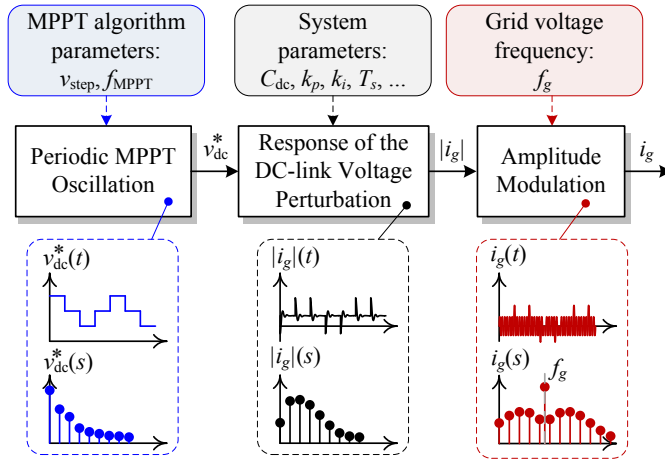

Fig. 3.4: Proposed modeling approach to identify interharmonics in the grid current with respect to the control parameters. Source: [J3].

algorithm parameters) on the interharmonic characteristic is taken into consideration at this modeling step.

- Response of the DC-link Voltage Perturbation:** The response of the DC-link voltage during the MPPT perturbation in the frequency domain can be modeled by considering the close-loop transfer functions of the DC-link voltage control loop, which can be modeled as it is shown in Fig. 3.5(a). The DC-link voltage controller is a Proportional-Integral (PI) controller, which generates the reference amplitude of the grid current. Then, the current control loop, which consists of the current controller, the pulse-width modulator, and the output filter transfer function, is responsible for regulating the grid current. Normally, the current control loop can be modeled as a first-order transfer function due to its much faster response compared to the DC-link voltage control loop, and thus their dynamics are decoupled [53]. For single-phase systems, the notch filter is normally employed to filter out the double-line frequency (e.g., 100 Hz) ripple in the DC-link voltage, and only the average value of the DC-link voltage v'_{dc} is controlled. The DC-link voltage control loop can be re-arranged to obtain the response of the grid current amplitude $|i_g|$ due to the DC-link voltage perturbation, as it is shown in Fig. 3.5(b).
- Amplitude Modulation:** From the response of the DC-link voltage controller in Fig. 3.5, the amplitude of the grid current during the MPPT perturbation can be modeled in the frequency domain. Following the control diagram in Fig. 3.2, the amplitude of the grid current $|i_g|$ is then

3.2. Modeling of Interharmonics

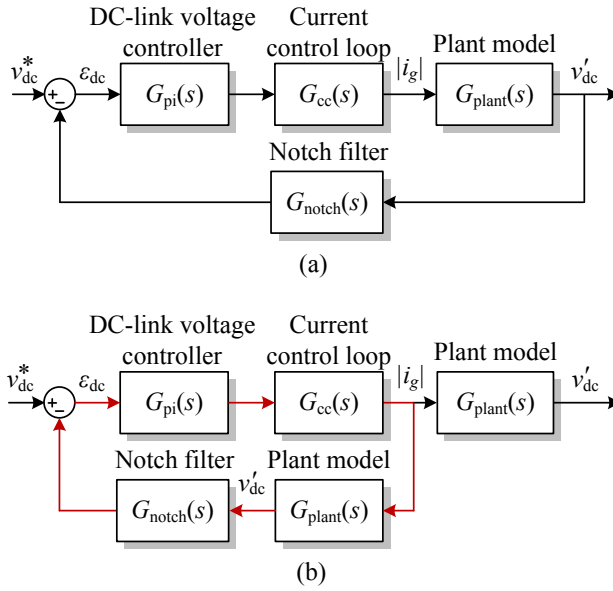

Fig. 3.5: Block diagram representing the transfer functions from the reference DC-link voltage to: (a) the measured DC-link voltage and (b) the amplitude of the grid current. Source: [J3].

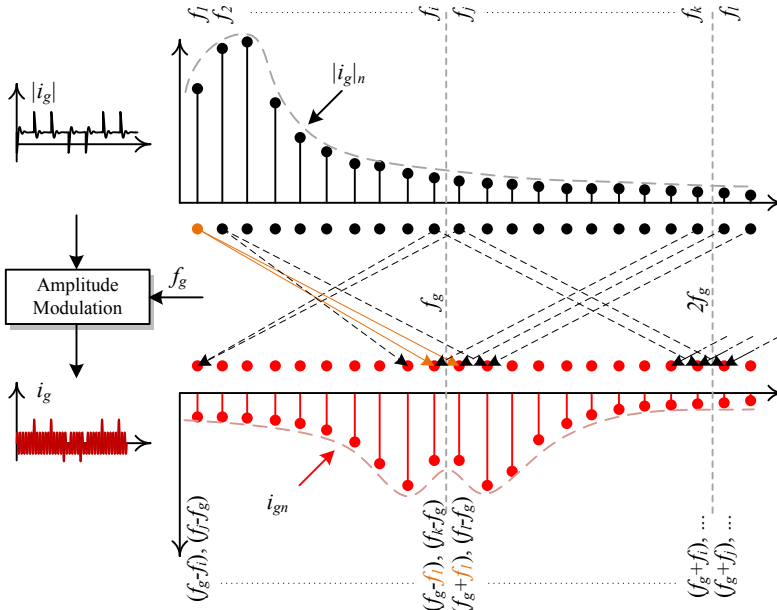

Fig. 3.6: Frequency mapping of the grid current i_g from the amplitude modulation between the amplitude of the grid current $|i_g|$ and the phase of the grid voltage $\sin(\theta_g)$. Source: [J3].

multiplied with the phase angle of the grid voltage $\sin(\theta_g)$ in order to obtain the reference grid current i_g^* . This multiplication in the time domain will result in the amplitude modulation of the two signals in the frequency domain, whose frequency mapping is illustrated in Fig. 3.6. Here, it can be noticed that each frequency component of the amplitude of the grid current $|i_g|$ will contribute to two interharmonic components in the grid current i_g after the amplitude modulation, where the envelope of the interharmonic frequencies is almost symmetrical around the fundamental frequency component (e.g., 50 Hz).

The control parameters used in the experiments in Fig. 3.3 are applied to the interharmonic model, and the results obtained from the model are compared with the experiments. The frequency spectrum of the DC-link voltage during the MPPT oscillation is shown in Fig. 3.7(a). Then, it can be used as an input to determine the response of the DC-link voltage perturbation, as it is shown in Fig. 3.7(b). Afterwards, the amplitude modulation between the amplitude of the grid current and the fundamental frequency of the grid voltage (i.e., 50 Hz) is applied, and the frequency spectrum of the grid current can be obtained, as it is shown in Fig. 3.7(c). It can be seen that the interharmonics in the grid current obtained from the proposed model are in close agreement with the experimental results in Fig. 3.7(d). Thus, the above results validate the effectiveness of the proposed interharmonic model.

3.3 Mitigation of Interharmonics

According to the previous analysis, the perturbation of the DC-link voltage during the MPPT operation is the main cause of interharmonics in the grid current. To address this issue, mitigation solutions to alleviate interharmonics in the grid current have been proposed in [C3].

- **Adaptive Gain of the DC-link Voltage Controller:** According to the analysis, the interharmonics in the grid current are induced by the DC-link voltage perturbation, which is mainly due to the transient response of the DC-link voltage controller. Thus, the control parameters of the DC-link voltage controller (i.e., a PI controller) can be designed to reshape the interharmonic characteristic. In order to do so, the proposed interharmonic model is employed to iteratively determine the proportional gain k_p and the integral gain k_i of the DC-link voltage controller, as it is shown in Fig. 3.8. An example of this mitigation solution is demonstrated in Fig. 3.9, where the dynamic response of the DC-link voltage controller is reduced through the design of the controller parameters (i.e., the proportional gain k_p and the integral gain k_i). Nevertheless, the reduced transient response of the DC-link voltage controller

3.3. Mitigation of Interharmonics

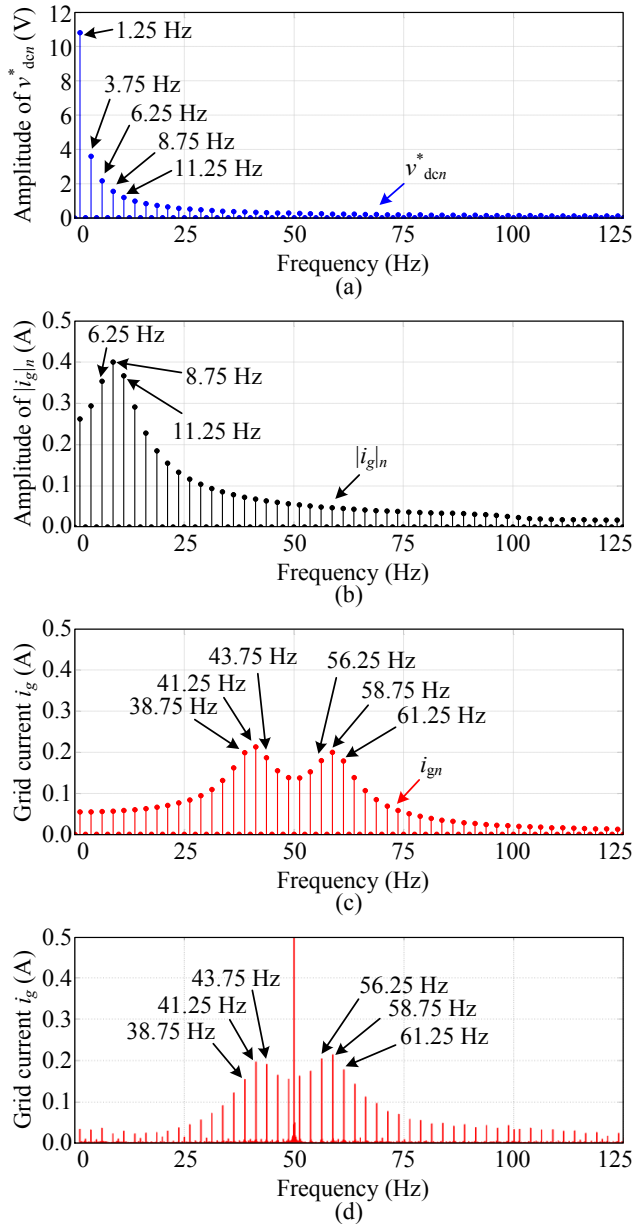

Fig. 3.7: Frequency spectrum obtained from the proposed interharmonic model: (a) reference dc-link voltage v_{den}^* , (b) amplitude of the grid current $|i_{gn}|$, (c) grid current i_{gn} (from the model), and (d) grid current i_{gn} from the measurement. Source: [J3].

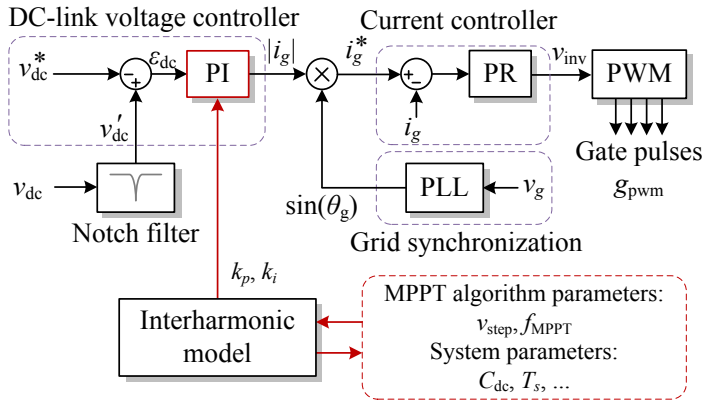

Fig. 3.8: Control structure of the PV inverter using an adaptive gain for the DC-link voltage controller. Source: [C3].

may limit the sampling rate of the MPPT algorithm, which affects the dynamic tracking performance (e.g., during a fast changing solar irradiance condition).

- Rate Limiter for the DC-link Voltage Controller:** A rate limiter can be employed to limit the change rate of the reference DC-link voltage (from the MPPT algorithm), as it is shown in Fig. 3.10. This approach is an alternative solution to ensure a smooth transition between each MPPT perturbation, and thus avoiding the transient response of the DC-link voltage controller. In this case, the reference DC-link voltage during each MPPT perturbation is changed in a ramp-changing manner, instead of using a typical step-change method. By doing so, the overshoot in the DC-link voltage during the transient (e.g., due to the perturbation) can be reduced. An example of the mitigation solution with a rate limiter for the DC-link voltage controller is shown in Fig. 3.11, where it can be seen that the reference DC-link voltage v_{dc}^* changes from the previous value to the new set-point with a ramp-changing manner. Notably, employing the rate limiter for the DC-link voltage controller will not affect the MPPT tracking performance as long as the reference DC-link voltage can reach the new set-point (given by the MPPT algorithm) within one MPPT sampling period (e.g., the typical MPPT sampling period is in the range of 0.1 - 1 second) [54].
- Constant-Voltage MPPT Method:** Another way to mitigate the interharmonics is to avoid the perturbation during the MPP searching. This can be achieved by employing different MPPT algorithms such as the constant-voltage MPPT algorithm [55], where the perturbation during

3.3. Mitigation of Interharmonics

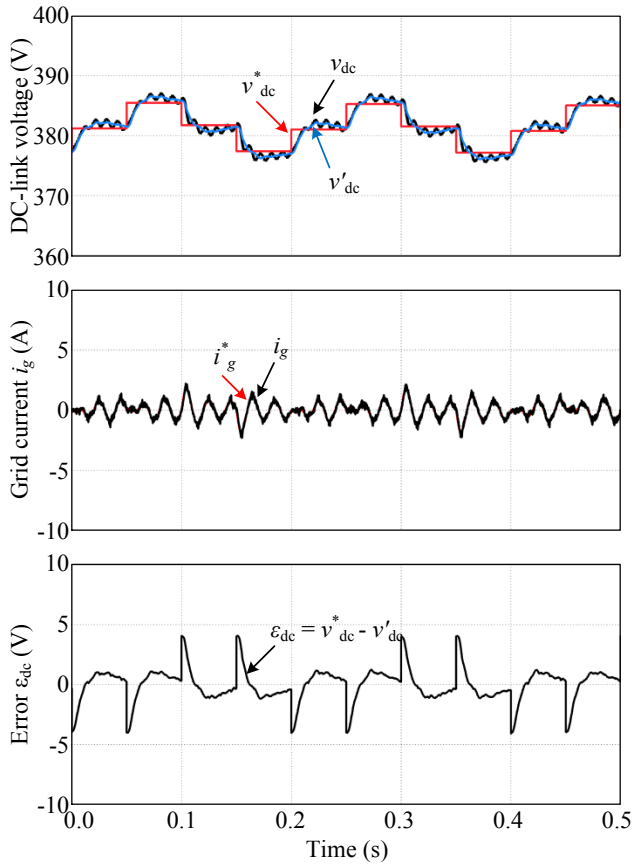

Fig. 3.9: Simulation results of the PV inverter operating at the steady-state MPPT operation (i.e., 0.15 kW) with an adaptive gain of the DC-link voltage controller solution. Source: [C3].

the MPP searching is not required. In this method, the voltage at the MPP is approximated as 71-78 % of the open-circuit voltage of the PV arrays, and the constant reference DC-link voltage is assigned as it is shown in Fig. 3.12. Since there is no perturbation in the DC-link voltage, the interharmonic induced by the MPPT perturbation will not appear in the grid current. In that regards, it is a very effective solution to avoid interharmonics induced by the MPPT operation. However, the trade-off of this solution is the tracking performance during the MPPT operation, as the applied constant-voltage reference is an approximation. For instance, the accuracy of this MPPT method may decrease considerably during the changing environmental condition, where the voltage at the MPP varies in a certain range (e.g., due to the change in the solar irradiance and ambient temperature conditions).

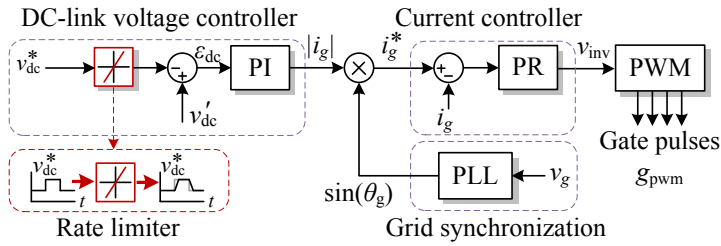

Fig. 3.10: Control structure of the PV inverter using a rate limiter of the DC-link voltage controller. Source: [C3].

To verify the effectiveness of the proposed interharmonic mitigation solutions, the frequency spectrum of the grid current with different mitigation solutions is shown in Fig. 3.13. Compared with the normal MPPT operation (i.e., a P&O MPPT algorithm), all three mitigation solutions can effectively reduce the interharmonics in the grid current. Employing mitigation solutions such as adaptive gain and rate limiter for the DC-link voltage controller result in a similar grid current waveform (see Fig. 3.9(b) and 3.11(b)). Therefore, they also have similar performance in terms of frequency spectrum, where the interharmonic frequencies above 100 Hz can be significantly suppressed, as it is shown in Fig. 3.13. However, the constant-voltage MPPT method can completely avoid the DC-link voltage perturbation during the MPPT operation. Therefore, it is the most effective solution to reduce the interharmonics in the grid current including the frequency component close to the fundamental frequency of the grid voltage (e.g., 50 Hz).

3.4 Summary

The analysis of the interharmonics from grid-connected PV systems was discussed in this chapter. It is confirmed by the experiments that the perturbation of the DC-link voltage during the MPPT operation is one main-cause of interharmonics in the grid current. To address this issue, the modeling approach to predict the interharmonics according to the control parameters (e.g., MPPT algorithm parameters, DC-link voltage controller parameters, and system parameters) has been proposed. The proposed interharmonic model has been validated by comparing the predicted interharmonics with the experimental measurements. A close agreement between the frequency spectrum of the predicted grid current and experimental measurements validates the effectiveness of the proposed model.

In addition, three interharmonics mitigation solutions have been discussed in this chapter. Re-designing the DC-link voltage controller parameters (i.e., PI controller parameters) by using the proposed interharmonic model to en-

3.4. Summary

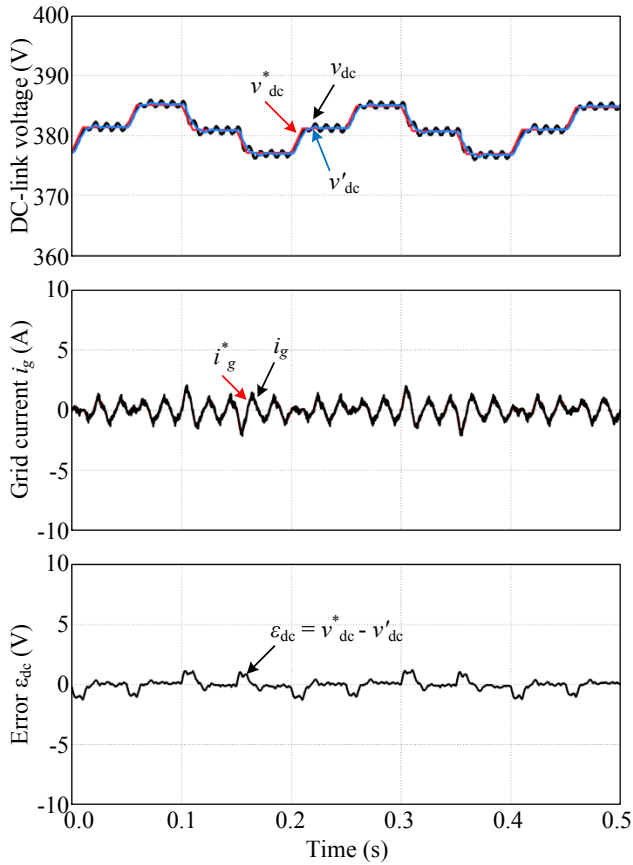

Fig. 3.11: Simulation results of the PV inverter operating at the steady-state MPPT operation (i.e., 0.15 kW) with a rate limiter for the DC-link voltage controller solution. Source: [C3].

sure the interharmonic level is one solution to alleviate the interharmonics issue. Another solution to reduce the interharmonics in the grid current is to employ a rate limiter of the DC-link voltage controller. In this method, a smooth transition between each MPPT perturbation can be ensured, reducing the grid current distortion. However, to effectively mitigate the interharmonics, the perturbation of the DC-link voltage during the MPPT operation should be avoided. This can be achieved by using a constant-voltage MPPT method at the cost of the MPPT accuracy. The frequency spectrum of the grid current with the mitigation solutions demonstrated the effectiveness of the proposed solutions in terms of reducing the interharmonics of the grid current.

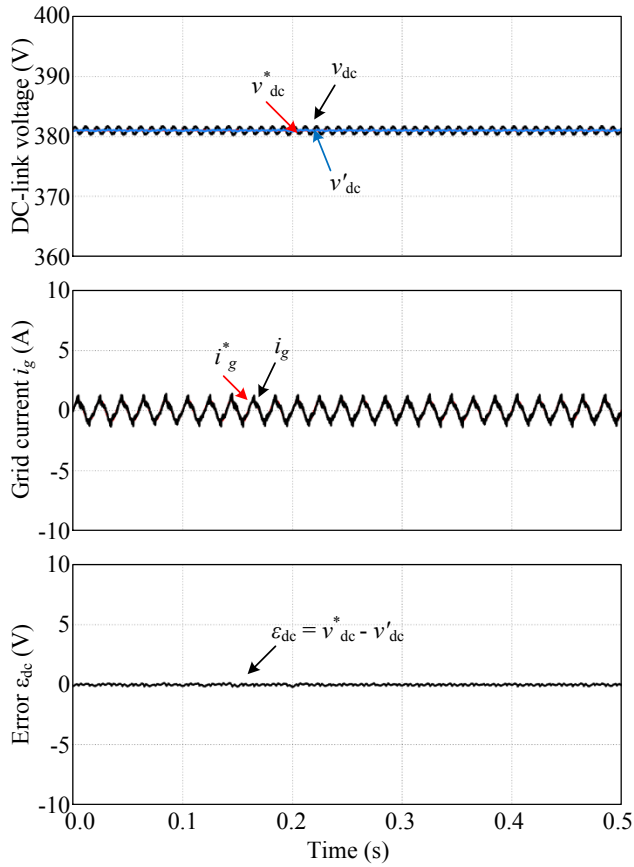

Fig. 3.12: Simulation results of the PV inverter operating at the steady-state MPPT operation (i.e., 0.15 kW) with a constant-voltage MPPT solution. Source: [C3].

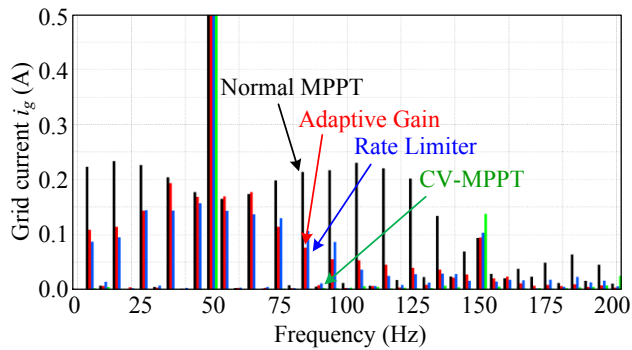

Fig. 3.13: Frequency spectrum of the grid current (output current) of the PV inverter operated at the MPPT operation with different interharmonic mitigation solutions. Source: [C3].

Related Publications

- J3. A. Sangwongwanich, Y. Yang, D. Sera, H. Soltani, and F. Blaabjerg,** "Analysis and Modeling of Interharmonics from Grid-Connected Photovoltaic Systems," *IEEE Trans. Power Electron.*, vol. PP, no. 99, pp. 1–1.

Main contribution:

The detailed analysis of the interharmonic from grid-connected PV system is discussed in this paper. The interharmonic model discussed in this chapter is also proposed and experimentally verified in this paper.

- C3. A. Sangwongwanich, Y. Yang, D. Sera, and F. Blaabjerg,** "Interharmonics from Grid-Connected PV Systems: Mechanism and Mitigation," *Proc. of IFEEC 2017 – ECCE Asia, Kaohsiung, 2017*, pp. 722–727.

Main contribution:

The mitigation solutions for interharmonic from grid-connected PV system are discussed in this paper. The effectiveness of the three mitigation solutions is verified through simulation. The results are discussed and compared.

Reliability of Power Electronics in PV Systems

4.1 Background

With a strong demand to ensure high reliability of power electronics in PV systems, the reliability engineering has been more and more involved in the design of PV inverters [38]. This is referred to as a Design for Reliability (DfR) approach, where the reliability specifications (e.g., the component lifetime target) are defined and need to be fulfilled during the design phase. By doing so, the unexpected operation and maintenance cost due to the inverter failures can be minimized, lowering the cost of PV energy. In the DfR approach, the reliability assessment plays an important role to ensure the reliability performance of the designed PV inverters. A comprehensive study about applying the DfR approach in the design of PV inverters has been discussed in [O1]. A general diagram of the reliability assessment process of PV inverter is illustrated in Fig. 4.1, where three major tasks are involved:

- **Mission Profile Translation to Thermal Loading:** In the DfR approach, the operating condition of the PV inverter during the specified service life, i.e., a mission profile, is required as the input of the reliability assessment process [56–58]. The solar irradiance and ambient temperature profiles are normally considered as the mission profile, which needs to be translated into the stress/loading of the reliability-critical components in the system [59, 60]. Usually, the power devices and DC-link capacitors are considered to be the life-limiting components in the PV inverter whose thermal loading is the main stress factor that accelerates the wear-out failure mechanism of the components [61–63].

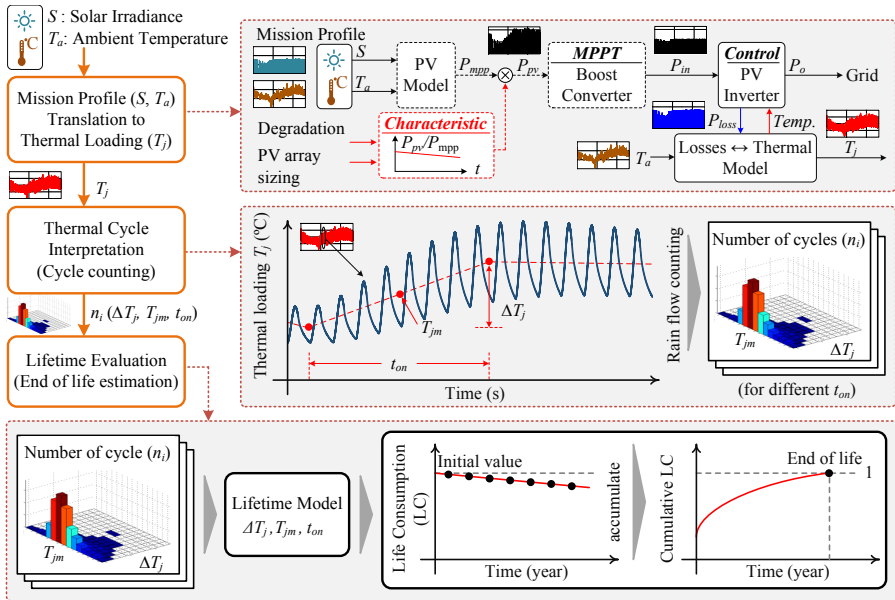

Fig. 4.1: Reliability assessment of PV inverters considering the mission profile and PV panel/array characteristics. Source: [J4].

- Thermal Cycling Interpretation:** In the case of the power devices, the main wear-out failure mechanism is related to the thermal cycling, which causes bond-wire lift-off and solder joint fatigue after a number of cycles [62–64]. Therefore, the thermal loading translated from the mission profile needs to be analyzed in order to determine the thermal cycling information. Typically, a cycle counting algorithm (e.g., the rainflow counting) is applied to extract the information such as the cycle amplitude, the mean value, and the cycle period of the thermal loading profile, which contains the mission profile dynamics [56].
- Lifetime Evaluation:** The lifetime or time-to-failure of the component (e.g., power devices and capacitors) can be modeled with respect to their stress factor and the failure mechanism. When applying the thermal stress information, e.g., obtained from the cycle counting algorithm, the corresponding Life Consumption (LC) or damage can be calculated for a given mission profile [39]. This parameter indicates how much lifetime of the component has been consumed during the operation. It is normally assumed that the LC is accumulated linearly and independently during the operation following the Miner’s rule [56]. The component is considered to reach its end-of-life when the LC is accumulated to 1, and the lifetime of the component can be determined.

4.1. Background

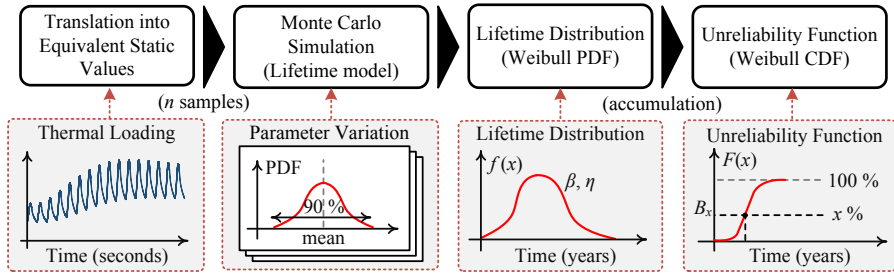

Fig. 4.2: Monte Carlo-based reliability assessment method with variations taken into account (PDF: Probability Density Function, CDF: Cumulative Density Function). Source: [J5].

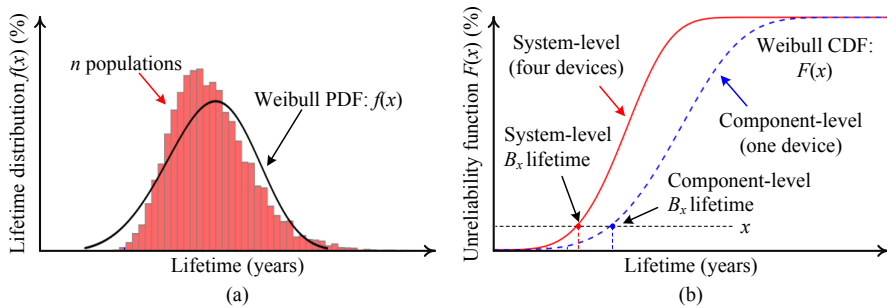

Fig. 4.3: Results from the Monte Carlo-based reliability assessment: (a) lifetime distribution of the component and (b) component-level and system-level unreliability functions.

While the reliability assessment procedure discussed above seems to be straight forward, there are several factors in the real-life applications which may introduce uncertainties in the evaluation results. For instance, the parameter variations in the lifetime model and the component characteristic (e.g., on-state voltage drop of the power device, equivalent series resistance of the capacitor) due to the manufacturing tolerance have a certain impact on the reliability evaluation results [39]. Moreover, the deviation can also be introduced by the mission profile uncertainties, which will be reflected in the variation in the stress condition. To address these uncertainties, the Monte Carlo simulation is employed in the reliability assessment process, where parameter variations are taken into consideration during the assessment, as it is illustrated in Fig. 4.2. The outcome of the Monte Carlo-based reliability assessment is the lifetime (failure rate) distribution of the components, as it is shown in Fig. 4.3(a). The probability of failure over-time (i.e., unreliability function) of the components in the system can be determined from the accumulation of the lifetime distribution, as it is shown in Fig 4.3(b). For instance, the B_x lifetime, which corresponds to the time when x % of the population have failed, is usually used as a reliability metric, as it gives a statistical infor-

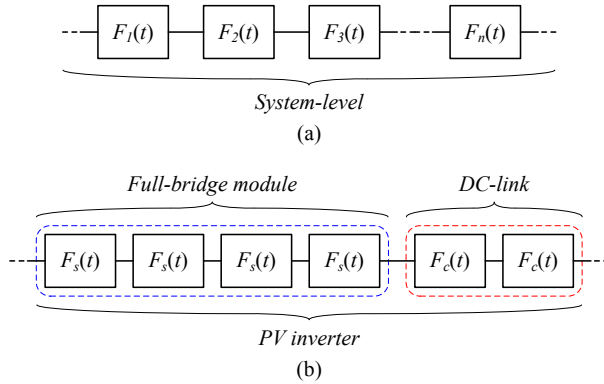

Fig. 4.4: Reliability block diagram of: (a) system with n components and (b) PV inverter with full-bridge module and DC-link ($F_s(t)$: unreliability of the power device, $F_c(t)$: unreliability of the capacitor) [J5].

mation of the failure rate. From the unreliability function of each individual component, a system-level reliability metric can be assessed through the reliability block diagram [41], as it is shown in Fig. 4.4, and the system-level unreliability is demonstrated in Fig. 4.3(b).

In addition to the variations discussed above (e.g., lifetime model and manufacturing tolerance), the PV panel/array characteristics also play an important role to determine the loading and thus the reliability of PV inverters. For instance, the aging of PV arrays usually leads to a continuous decrease in the PV output power, known as the PV array degradation [65–68]. Another concern regarding the impact of PV array characteristic on the inverter reliability is related to the PV array oversizing [69–71]. When the PV arrays are oversized, the time duration where the PV inverter operates close to the rated power will be prolonged during the day. This will lead to an increase in the loading of PV inverters [72, 73]. In both cases, the reliability of the PV inverter will be affected to a certain extent. In this chapter, the influence of the degradation rates and oversizing of the PV arrays on the reliability performance of PV inverters will be analyzed.

4.2 Degradation Rates of PV Arrays

In addition to the mission profile of the PV system (i.e., solar irradiance and ambient temperature), the long-term PV power production is strongly dependent on the degradation of the PV arrays. In fact, the degradation rate of the PV arrays varies with the installation location, where the dry and hot climate conditions tend to accelerate the degradation of the PV arrays [2, 74–76].

4.2. Degradation Rates of PV Arrays

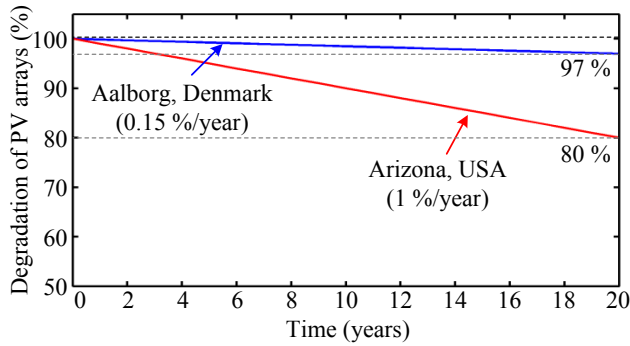

Fig. 4.5: Degradation profile of the PV arrays installed in Denmark and Arizona with the degradation rate of 0.15 %/year and 1 %/year, respectively. Source: [J4].

An example of the PV array degradation based on the field-measurement in Denmark (i.e., cold climate condition) and Arizona (i.e., hot and dry climate condition) is shown in Fig. 4.5 [77–79]. Notably, in this case, a linear degradation rate is assumed. It can be seen that the PV array degradation rate in Arizona is much higher than that in Denmark due to the climate condition of the installation site. The impacts of the PV array degradation on the thermal loading and reliability performance of the PV inverter have been discussed in [J4], and will be summarized in the following.

4.2.1 Thermal Loading

The impact of PV array degradations on the thermal loading of the PV inverter can be examined by considering the junction temperature variation of the power devices. The thermal cycle amplitude ΔT_j and the mean junction temperature T_{jm} are the two main stress factors that accelerate the wear-out failure mechanism of power devices. The thermal loading of the power device of PV inverter under the mission profile in Denmark and Arizona are shown in Fig. 4.6(a) and 4.6(b), respectively. In both cases, the thermal loading of the PV inverter with and without considering the PV array degradation are considered for comparison. Due to a relatively high degradation rate of the PV arrays installed in Arizona, the thermal loading of the PV inverter in Arizona reduces significantly after five years of operation, while the thermal loading difference is very small in the case of PV inverters in Denmark.

4.2.2 Reliability Evaluation

By applying the thermal loading in Fig. 4.6, the reliability performance of the PV inverter can be evaluated following the diagram in Fig. 4.1. The unreliability function of the PV inverter under different mission profiles are shown

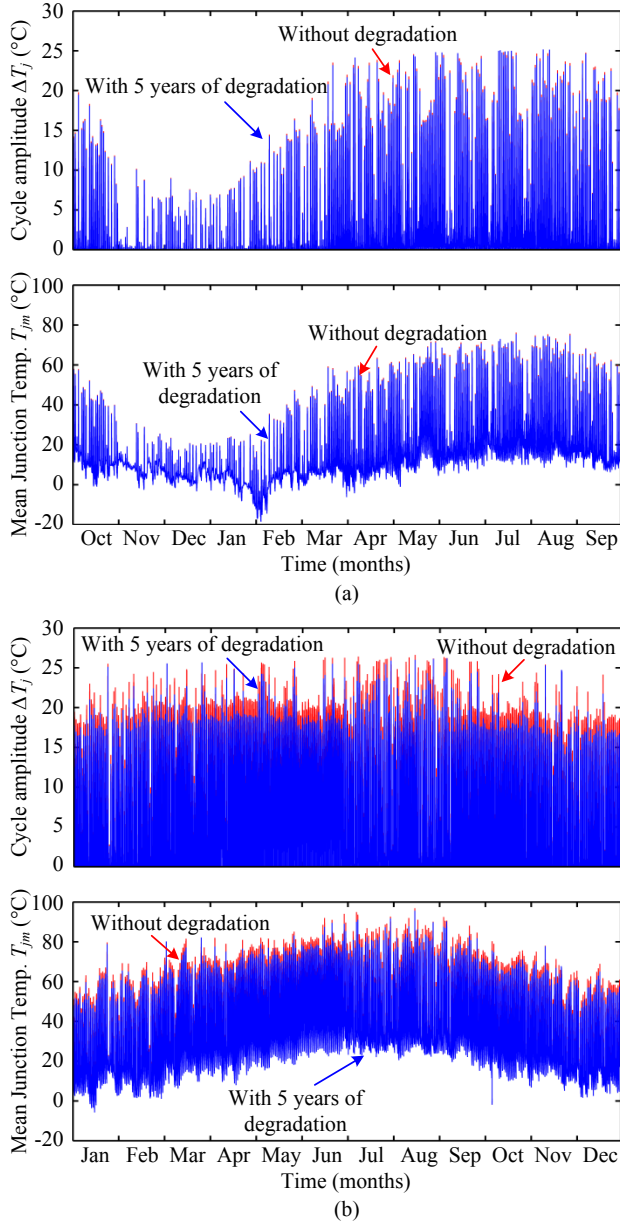

Fig. 4.6: Thermal loading of the power device (i.e., cycle amplitude and mean junction temperature) under a yearly mission profile in: (a) Denmark and (b) Arizona. Source: [J4].

4.2. Degradation Rates of PV Arrays

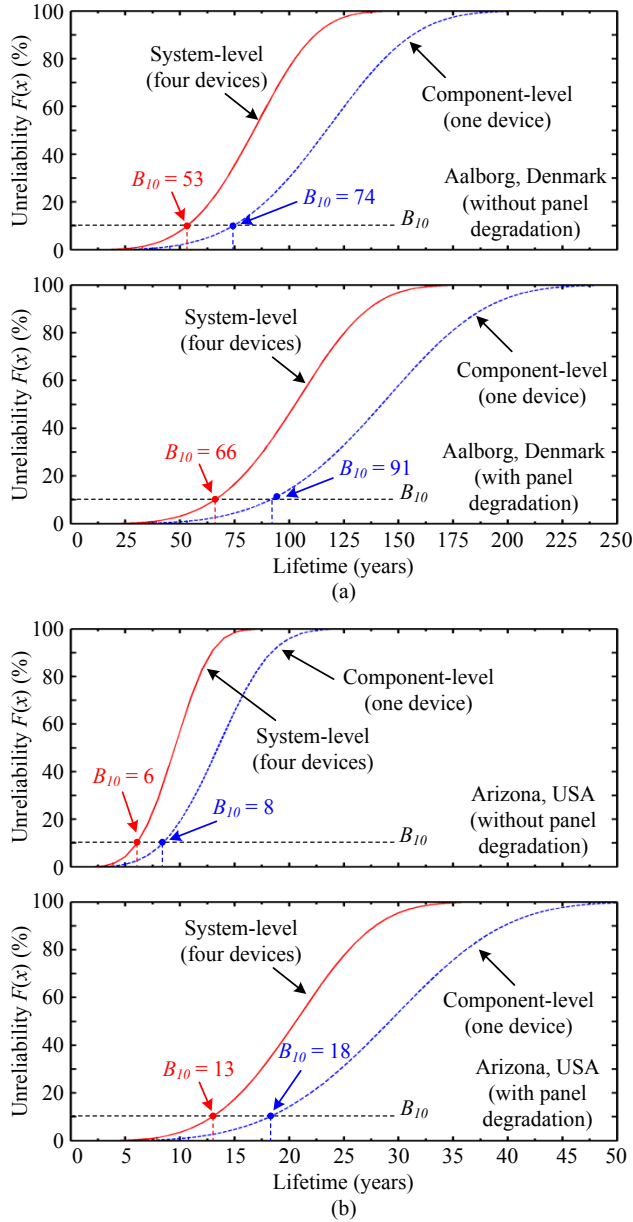

Fig. 4.7: Reliability performance of the PV inverter (i.e., unreliability function) under a yearly mission profile in: (a) Denmark and (b) Arizona. Source: [J4].

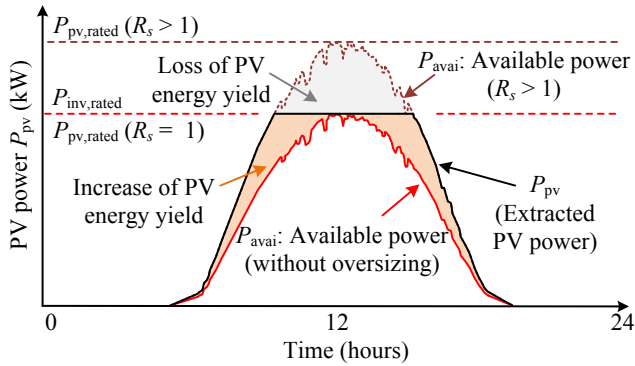

Fig. 4.8: PV power extraction of the PV inverter during one-day with oversized PV arrays (P_{avai} : available PV power, P_{pv} : extracted PV power, $P_{\text{pv,rated}}$: PV array rated power, $P_{\text{inv,rated}}$: PV inverter rated power, $R_s = P_{\text{pv}}/P_{\text{inv,rated}}$: sizing ratio). Source: [J5].

in Fig. 4.7, where the B_{10} lifetime of the power device (i.e., component-level) and the inverter (i.e., system-level) are considered as the reliability metrics. It can be seen from the results in Fig. 4.7(a) that the system-level B_{10} lifetime of the PV inverter installed in Denmark is underestimated by 20 %, if the PV array degradation is not considered during the reliability assessment. In the case of PV inverters in Arizona, the deviation in the system-level B_{10} lifetime is as high as 54 % (7 years), due to the higher degradation rate of the PV arrays, as it is shown in Fig. 4.7(b). In both cases, a certain deviation in the reliability evaluation is introduced, if the PV array degradation impact is considered, which affects the operation and maintenance cost estimation.

4.3 Oversizing of PV Arrays

Oversizing the PV arrays, where the rated installed power of the PV arrays is intentionally designed to be higher than the PV inverter rated power, has become an attractive solution to reduce the cost of PV energy recently [42, 72, 80]. The benefit of doing so is the increase in the PV energy yield during the low solar irradiance condition, as it is illustrated in Fig. 4.8. Since the cost of PV arrays is still declining, the extra initial cost introduced by the PV arrays is relatively low compared to the increase in energy yield. Thus, the overall cost of PV energy can be reduced considerably by oversizing the PV arrays.

From a reliability perspective, the consequence of oversizing the PV arrays is the increase in the loading of the PV inverter. This will inevitably increase the stress of the components in the inverter, and thus affect their reliability performance. While the risk of decreasing the PV inverter reliability due to the PV array oversizing has been pointed out in the previous study [72,

4.3. Oversizing of PV Arrays

73], an in-depth analysis to quantify the required design margin in terms of the reliability of PV inverters has not been discussed in the literature. Such analysis is required to ensure the reliability performance of the designed PV inverter following the DfR approach. This issue has been addressed in [J5], and will be summarized in the following by using the reliability assessment method in Fig. 4.1.

4.3.1 Thermal Loading

The impact of PV array oversizing on the thermal loading of the components in the PV inverter is investigated by considering the cycle amplitude ΔT_j and the mean value T_{jm} of the junction temperature of the power device and the hotspot temperature T_h of the DC-link capacitor. Here, two cases with the sizing ratio $R_s = 1$ (i.e., non-oversized PV arrays) and $R_s = 1.4$ (i.e., oversized PV arrays) are compared for each mission profile. According to the results in Fig. 4.9, the thermal loading of the components of the PV inverter installed in Denmark increases considerably when the PV arrays are oversized, especially during the winter periods. In contrast, the impact of PV arrays oversizing is less pronounced with the installation in Arizona, as it is shown in Fig. 4.10. In that case, the PV inverter mostly operates in the power limiting mode due to the relatively high solar irradiance condition. Thus, the increase in the thermal loading of the PV inverter due to the oversizing is relatively small.

4.3.2 Reliability Evaluation

The reliability evaluation was carried out to analyze the influence of the PV array sizing on the reliability of the PV inverter. The B_{10} lifetime of the PV inverter with different PV array sizing ratios for the installation site in Denmark and Arizona are shown in Fig. 4.11(a) and 4.11(b), respectively. Similar to the thermal loading analysis, the sizing ratio of PV arrays has a strong impact on the reliability of the PV inverter installed in Denmark due to the mission profile characteristic. When the sizing ratio increases from $R_s = 1$ to $R_s = 1.4$, the reliability performance of the PV inverter (i.e., the B_{10} lifetime) is deviated by more than 40 %. This indicates that a certain design margin in terms of reliability performance is required in order to ensure a highly reliable operation of the PV inverter in Denmark under various PV array sizing ratios. In contrast, the difference in the B_{10} lifetime of the PV inverter installed in Arizona is less affected by the PV array oversizing, where the deviation in the reliability performance is less than 22 % over the wide-range of PV arrays sizing ratios. In both cases, it can be seen that the DC-link capacitors are the weakest components in the system, which may need to be re-designed to improve the reliability of the overall system. Otherwise, other measures should be taken to enhance the reliability of the entire system.

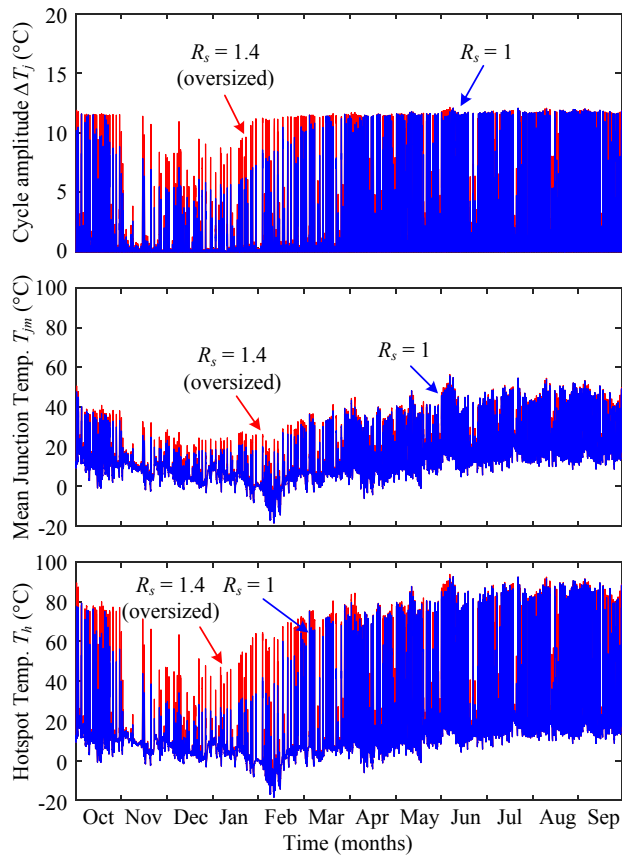

Fig. 4.9: Thermal loading of the power device (cycle amplitude and mean junction temperature) and capacitor (hotspot temperature) under a mission profile in Denmark. Source: [J5].

4.4 Summary

In this chapter, the reliability of the power electronics in PV systems was studied considering the PV array degradation and oversizing issues. The design for reliability was employed to assess the reliability of the PV inverter based on the mission profile, where the mission profile translation to thermal loading, thermal cycling interpretation, and lifetime evaluation are involved. Monte Carlo simulations were also employed to address the uncertainties in the reliability evaluation introduced by, e.g., lifetime modeling and variations in the stress conditions. By doing so, the reliability of the PV inverter can be expressed in terms of statistical values (e.g., failure distribution, unreliability function, B_{10} lifetime), which is commonly used in the reliability analysis.

4.4. Summary

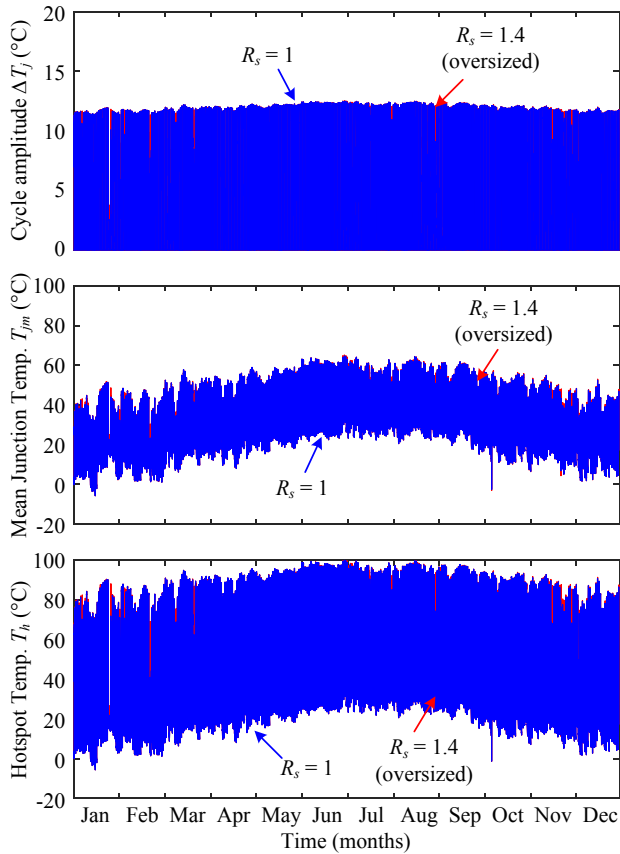

Fig. 4.10: Thermal loading of the power device (cycle amplitude and mean junction temperature) and capacitor (hotspot temperature) under a mission profile in Arizona. Source: [J5].

For the PV applications, the operation and performance of the PV inverter are also dependent on the PV array characteristics, which are considered as another source of uncertainties in the reliability evaluation. From a reliability point of view, the PV array degradation and oversizing are the two main aspects that can strongly affect the loading and reliability of the PV inverter. The degradation of PV arrays leads to a continuous decrease in the PV output power and thereby the loading of the PV inverter. The results showed that the reliability performance of the PV inverter can be considerably affected by the PV array degradation rate. Specifically, the deviation in the reliability evaluation results can be as large as 54 %, if the PV array degradation is not considered. The impact of PV array sizing on the PV inverter reliability has also been analyzed in this chapter. While oversizing the PV arrays can reduce the cost of PV energy, it also increases the risk of PV inverter failures

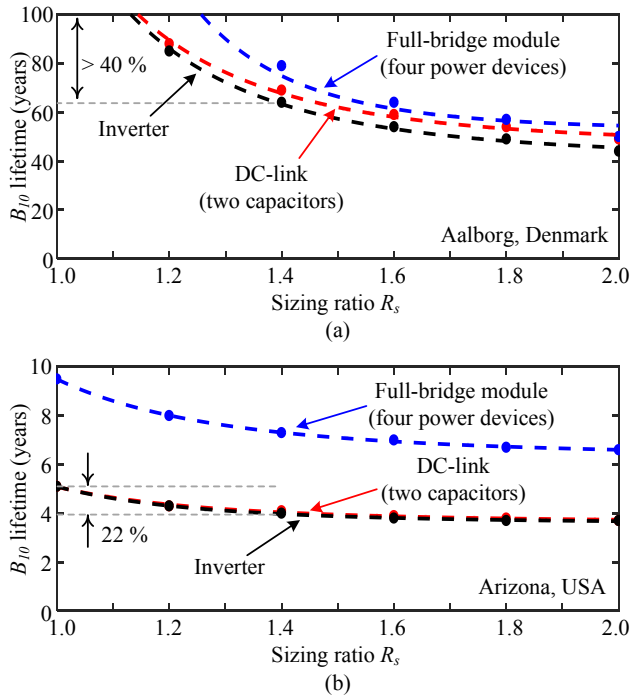

Fig. 4.11: Reliability performance of the PV inverter (i.e., B_{10} lifetime) with different PV arrays sizing ratios for the mission profile in: (a) Denmark and (b) Arizona. Source: [J5].

due to the increased loading. In the case of the mission profile with low solar irradiance conditions (e.g., Denmark), the oversizing of the PV arrays can decrease the reliability performance of the PV inverter (i.e., B_{10} lifetime) by more than 40 % compared to the case with non-oversized PV arrays. In that case, a certain design margin in terms of reliability is strongly required in order to ensure high reliability of the PV inverter under various PV array sizing ratios.

Related Publications

- O1.** Y. Yang, A. Sangwongwanich, and F. Blaabjerg, "Design for Reliability of Power Electronics for Grid-Connected Photovoltaic Systems," *CPSS Trans. Power Electron. App.*, vol. 1, no. 1, pp. 92–103, Dec. 2016.

Main contribution:

In this paper, an overview of design for reliability approach is discussed and applied to the design of power electronics in PV systems. A step-by-step guideline for the reliability evaluation of PV inverters based

4.4. Summary

on the mission profile is provided and used as a key methodology for analyzing the impact of PV array characteristic.

- J4. A. Sangwongwanich, Y. Yang, D. Sera, and F. Blaabjerg, "Lifetime Evaluation of Grid-Connected PV Inverters Considering Panel Degradation Rates and Installation Sites," *IEEE Trans. Power Electron.*, vol. 33, no. 2, pp. 1225–1236, Feb. 2018.**

Main contribution:

The impact of PV array degradation on the reliability performance of the PV inverter is analyzed in this paper. The analysis consider the installation sites in Denmark and Arizona with different PV array degradation rates. The deviation in the reliability evaluation results between the case with and without considering the PV array degradation is discussed and compared.

- J5. A. Sangwongwanich, Y. Yang, D. Sera, F. Blaabjerg, and D. Zhou, "On the Impacts of PV Array Sizing on the Inverter Reliability and Lifetime," *IEEE Trans. Ind. App.*, vol. PP, no. 99, pp. 1–1.**

Main contribution:

This paper addresses the impact of PV array sizing on the reliability of the PV inverters. The analysis includes the two most reliability-critical components in the PV inverters: power devices and DC-link capacitors, whose reliability has been evaluated under various PV array sizing ratios. The evaluation results cover from the component-level to the system-level (i.e., PV inverter) reliability performance, where the weakest component in the system can be allocated (e.g., DC-link capacitors) for the purpose of improving the design.

Enhanced PV Inverter Reliability with Batteries

5.1 Background

Recently, the integration of battery system in residential grid-connected PV systems has become more and more economically viable and attractive [81–83]. One application example is the PV self-consumption, where the generated PV power is consumed locally (within the household) as much as possible, and only the surplus PV power is being fed into the grid [12]. In that case, the battery system is employed to store the surplus PV energy during the day and supply the load demand during the night in order to increase the self-consumption rate and thus reduce the cost of energy. In general, there are two main types of the PV system with integrated Battery Energy Storage Systems (PV-BESS): DC and AC coupled battery system. In this Ph.D. project, the PV-BESS with DC coupled configuration is considered, whose system diagram is shown in Fig. 5.1. An operational example of the PV self-consumption during one day is demonstrated in Fig. 5.2.

To ensure a better cost competitiveness of PV-BESS, a highly reliable operation is demanded. PV inverters have been reported as one of the reliability-critical components in the overall system, whose failures can lead to a negative impact on the cost of PV energy. Therefore, improving the PV inverter reliability has high potential for a significant cost reduction in PV-BESS. In fact, the battery system operation can affect the PV inverter loading and thereby reliability, following the power flow diagram in Fig. 5.1. More specifically, the loading of the PV inverter is affected by the charging/discharging power of the battery in addition to the PV array output power. For instance, in the case

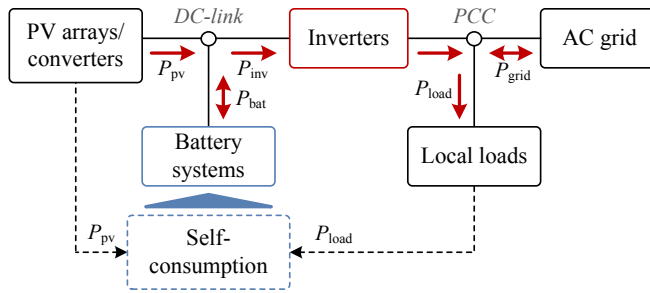

Fig. 5.1: System diagram of PV systems with integrated battery systems (P_{pv} : PV array output power, P_{bat} : battery power, P_{inv} : PV inverter power, P_{load} : load consumption, and P_{grid} : power exchanged with the grid). Source: [J6].

of PV self-consumption, the PV inverter will experience less loading during the day, since part of the PV energy will be stored in the battery. On the other hand, the loading of the PV inverter during night will increase (compared to the case without battery system) since the battery system needs to supply the load through the inverter. The one-day loading of the PV inverter with battery systems is demonstrated in Fig. 5.2(d). Inevitably, the PV inverter reliability will be affected by the battery system operation, which should be analyzed to ensure a highly reliable operation of PV inverters. In this chapter, the impact of battery system operation on the PV inverter reliability will be addressed, where the battery system parameters and control strategy are considered.

5.2 Reliability Assessment of PV Inverters with Battery Systems

The reliability assessment of PV inverters with battery systems is discussed in [C4] with the flow diagram illustrated in Fig. 5.3. First, the mission profile of the PV system (i.e., solar irradiance and ambient temperature) needs to be translated into the output power of the PV array. Then, the PV inverter loading is determined by subtracting the PV array output power with the battery power, which is obtained from the self-consumption control strategy. In this way, the impact of battery system operation can be reflected in the loading of PV inverter during the operation. Afterwards, the thermal loading of the power devices and the corresponding damage accumulated during the operation can be determined.

5.2. Reliability Assessment of PV Inverters with Battery Systems

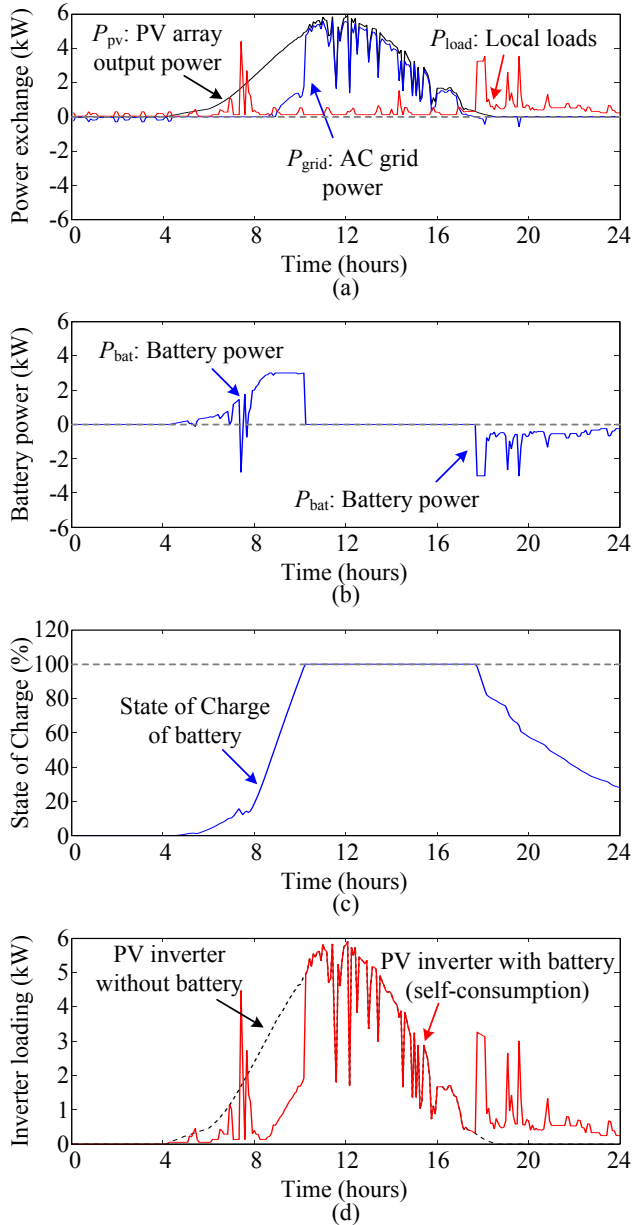

Fig. 5.2: Daily operation of a PV-BESS with self-consumption: (a) PV array output power P_{pv} , household load consumption P_{load} , and power exchanged with the grid P_{grid} , (b) battery power P_{bat} , (c) state of charge of the battery, and (d) loading of the PV inverter P_{inv} . Source: [C4].

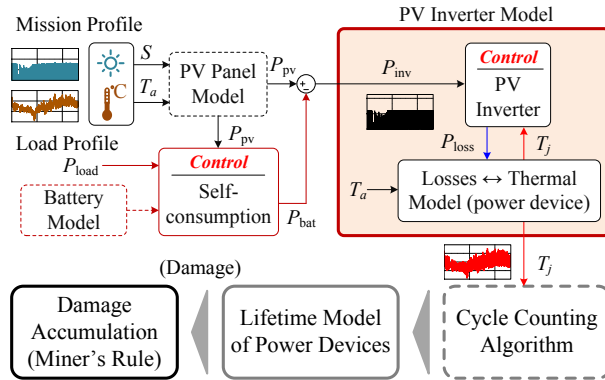

Fig. 5.3: Reliability assessment of PV inverter with battery storage systems considering mission profiles and PV self-consumption. Source: [C4].

5.2.1 Reliability Evaluation

The impact of battery system operation (i.e., self-consumption) on the reliability of PV inverters can be evaluated by considering the damage in the power device. In Fig. 5.4, the operation during one day is considered, and the damage in the power device of the PV inverter with and without battery systems are compared. It can be seen from the results in Fig. 5.4 that the damage in the power device is reduced significantly during the battery-charging period (i.e., 8:00-10:00). In the case of PV inverters with battery systems, a small increase in the loading has been observed around 18:00, corresponding to the discharging period of the battery. However, the increased PV inverter loading at night is relatively low. Thus, its contribution to the damage is not significant. When accumulating the damage during the entire day, the operation of the battery system can reduce the accumulated damage in the power device by 8 %, as it is shown in Fig. 5.4.

Due to the seasonal variation in the mission profile (e.g., during summer and winter), the one-year operation is also considered for the reliability analysis. The corresponding damage in the power device and its accumulation are shown in Fig. 5.5. In general, the damage in the power device of the PV inverter with batteries is lower than that in the case of no batteries. When considering the operation during the entire year, the accumulated damage in the power device of the PV inverter with battery systems is 11 % lower than the case without battery systems. Thus, the reliability of the PV inverter can be improved with the battery systems.

5.2. Reliability Assessment of PV Inverters with Battery Systems

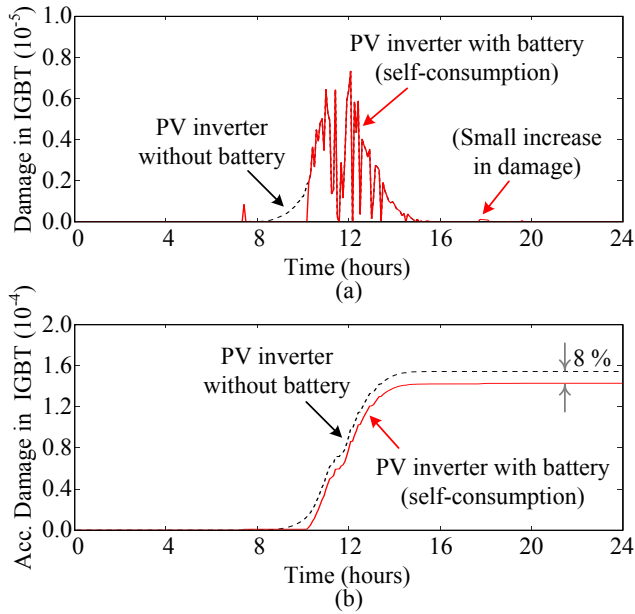

Fig. 5.4: Reliability evaluation of the power device in a PV inverter during one-day operation: (a) the damage and (b) the accumulated damage. Source: [C4].

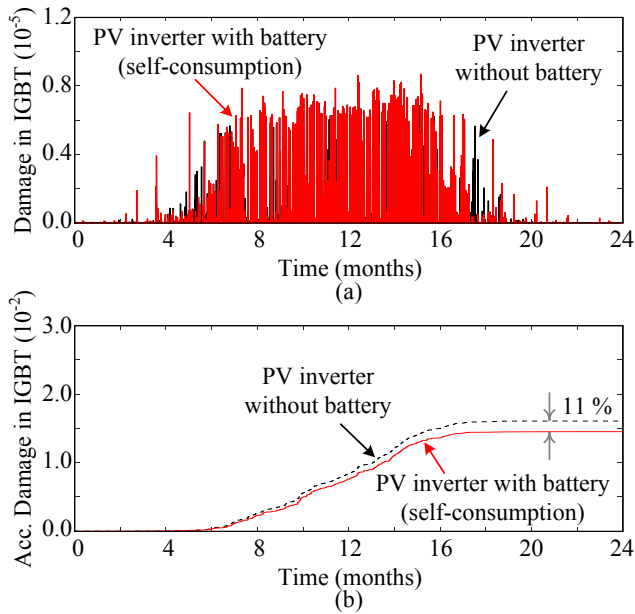

Fig. 5.5: Reliability evaluation of the power device in a PV inverter during one-year operation: (a) the damage and (b) the accumulated damage. Source: [C4].

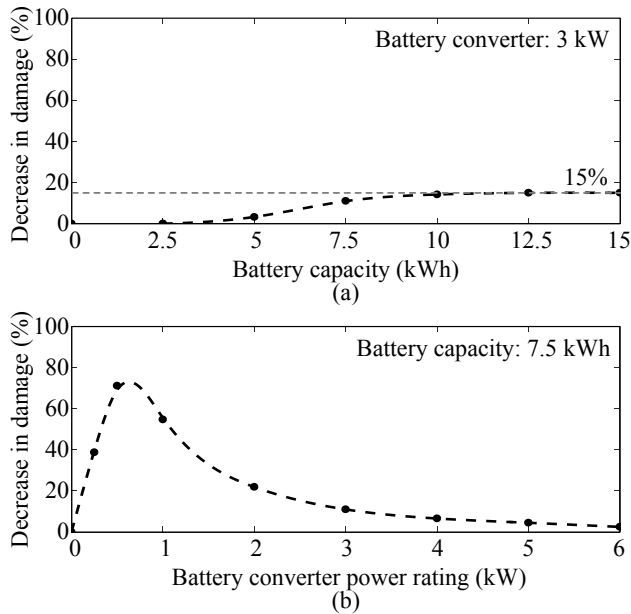

Fig. 5.6: Influences of the battery system parameters on the long-term (one-year) decrease in the accumulated damage of the PV inverter (compared to the case without the battery system) with different: (a) battery capacities and (b) battery converter power ratings. Source: [C4].

5.2.2 Impacts of the Battery System Parameters

The battery capacity is the parameter that strongly affects the battery system operation [84, 85]. A large battery capacity will prolong the charging process and ensure that more PV inverter loading during the day will be shifted to the night. Therefore, increasing the battery capacity will improve the overall PV inverter reliability. The impact of the battery capacity on the PV inverter reliability is analyzed with a one-year operation, and the results are shown in Fig. 5.6(a). In general, the accumulated damage decreases with a large battery capacity. However, when the battery capacity is further increased higher than 10 kWh, the damage difference is saturated around 15 % of the initial value. In that case, the battery is not being fully charged (i.e., during the day) or discharged (i.e., during the night). This means that the battery power profile is not affected by the battery capacity.

In addition, the battery converter power rating is another system parameter that affects the charging/discharging time duration of the battery. Using a battery converter with a low power rating can prolong the charging/discharging time duration. In that case, more peak load during midday will be stored in the battery. It can be seen from the results in Fig. 5.6(b) that the damage of the PV inverter decreases significantly as the battery converter

power rating decreases. Thus, using a small battery converter will improve the PV inverter reliability. However, when the battery converter power rating becomes too low (e.g., below 0.6 kW), the charging/discharging power is not enough to fully charge the battery and supply the load demand. In that case, the damage of the PV inverter is not further decreased with reducing the battery converter power rating. In other words, the battery is not being utilized and the loading of the PV inverter becomes comparable with the case without a battery system.

5.3 Enhanced PV Inverter Reliability with Battery Control

As discussed in the previous section, the integration of battery system to the PV system has a high potential to improve the PV inverter reliability, where the operation of the battery system (e.g., charge/discharge) changes the loading of the PV inverter. In that case, the control strategy of battery systems will affect the PV inverter loading and thereby also the reliability. The potential solution to enhance the PV inverter reliability through the control of battery systems considering the PV self-consumption operation has been investigated in [J6] and will be discussed in this section.

5.3.1 Control Strategy of the PV Self-Consumption

The basic concept of the PV self-consumption is to locally consume the generated PV electricity within the household, instead of drawing electricity from the grid to supply the loads. There are several control strategies to achieve the self-consumption operation [86], whose operational principle will be discussed in the following.

- **Maximizing Self-Consumption:** The most commonly-used battery system control strategy within the self-consumption scheme is the maximizing self-consumption [86]. In this control strategy, the battery is charged as soon as the surplus PV power becomes positive (e.g., the PV power is higher than the load demand), as it is demonstrated by simulations in Fig. 5.7(a). By doing so, it can be ensured that the self-consumption rate is maximized. However, this control strategy usually leads to a situation where the battery is fully charged before noon. This is undesirable since the battery system cannot contribute to the PV peak power reduction (e.g., the battery is fully charged before midday) [87]. Additionally, the early fully charged batteries will lead to a high average State of Charge (SOC) during operation, as it can be seen from the result in Fig. 5.7(b), which will accelerate the calendar aging (degradation) of some battery types (e.g., lithium-ion batteries) [88].

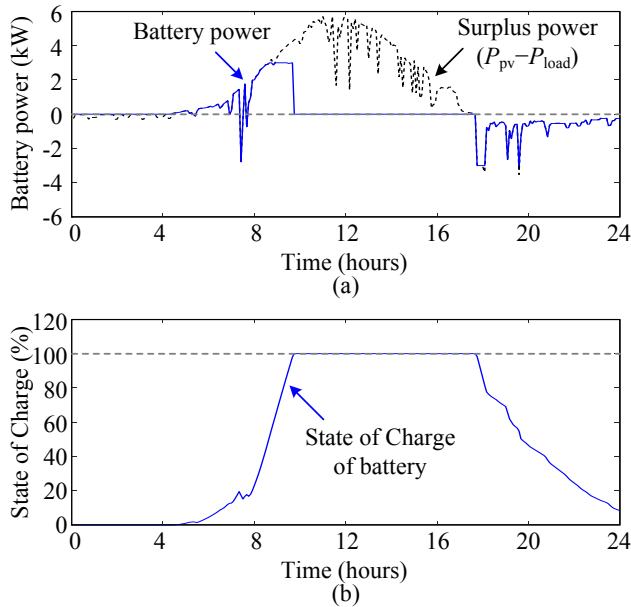

Fig. 5.7: Operation principle of PV-BESS during one day with the maximizing self-consumption control strategy: (a) battery power and (b) battery state of charge. Source: [J6].

- Delaying Charging Period:** With the delaying charging period control strategy, the battery will not be charged as soon as the surplus PV power becomes positive [89]. In contrast, the battery will be charged after a certain time period in a way to shift the charging period from the early morning to the midday, as it is shown in Fig. 5.8(a). The SOC of the battery with the delaying charging period control strategy is demonstrated in Fig. 5.8(b). Compared to the maximizing self-consumption control strategy, the average SOC of the battery is effectively reduced. As a consequence, the lifetime of the battery can be improved and a certain amount of PV peak power injected into the grid is reduced. However, this control strategy may reduce the self-consumption rate in the case of a low solar irradiance condition, if the battery is not being fully charged by the end of the day
- Limiting Charging Power:** Limiting the charging power of the battery to a certain value is another possible solution to avoid the battery to be fully charged early in the day [90]. The operation of this control strategy is demonstrated in Fig. 5.9(a), where the maximum charging power of the battery is kept at 30 % of the battery converter power rating. As a result, the battery charging time is prolonged and the average SOC of the battery shown in Fig. 5.9(b) can be effectively reduced. However, its

5.3. Enhanced PV Inverter Reliability with Battery Control

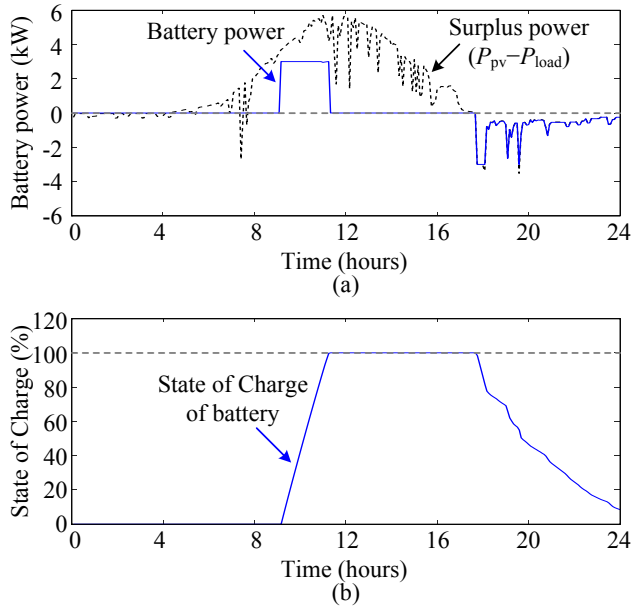

Fig. 5.8: Operation principle of PV-BESS during one day with the delaying charging period control strategy: (a) battery power and (b) battery state of charge. Source: [J6].

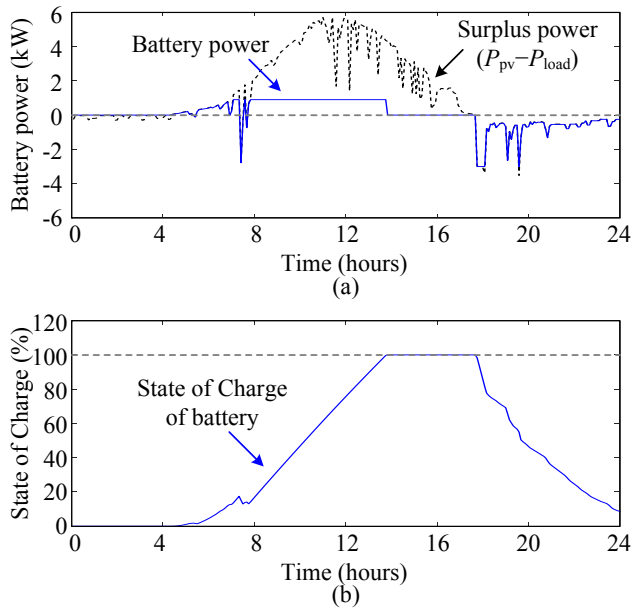

Fig. 5.9: Operation principle of PV-BESS during one day with the limiting charging power control strategy: (a) battery power and (b) battery state of charge. Source: [J6].

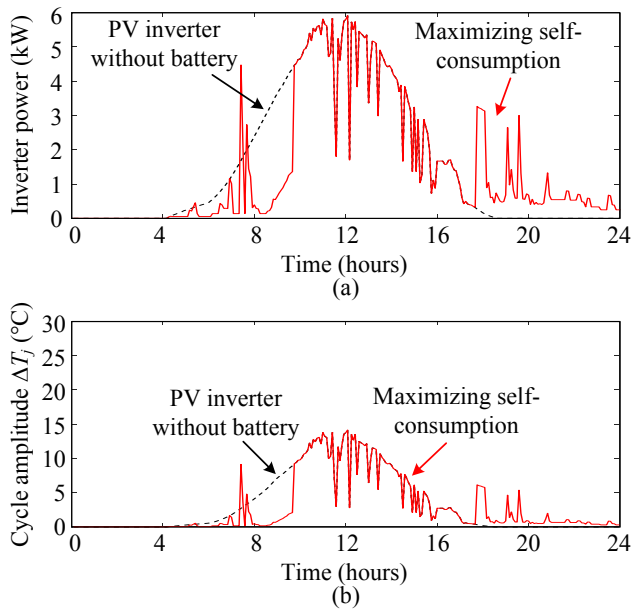

Fig. 5.10: Loading of the PV inverter during one day with the maximizing self-consumption control strategy: (a) input power and (b) thermal cycle amplitude. Source: [J6].

contribution to the grid-relieving is limited, since a part of the surplus power will be injected to the grid due to the limited battery charging power. Moreover, the self-consumption rate may be reduced in a low irradiance day if the battery is not fully charged.

5.3.2 PV Inverter Loading and Reliability

The impact of battery system control strategies on the PV inverter reliability can be investigated by comparing the PV inverter loading (i.e., the input power of the PV inverters) during the one-day operation with different battery system control strategies. It can be seen from the results in Fig. 5.10(a) that the maximizing self-consumption control strategy can reduce the input power of the PV inverter during the early morning. However, the peak load during noon remains the same as the case of PV inverters without a battery system. On the other hand, the loading of PV inverters during the PV peak power generation period can be reduced with the delaying charging period and limiting charging power control strategies, as it can be seen in Figs. 5.11(a) and 5.12(a). In the case of the limiting charging power control strategy, the maximum input power of the PV inverter is also reduced with the power difference of the maximum charging power of the battery system.

5.3. Enhanced PV Inverter Reliability with Battery Control

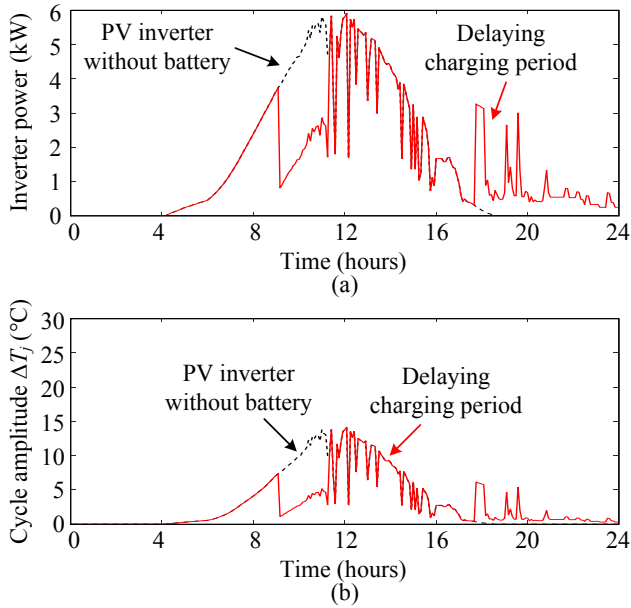

Fig. 5.11: Loading of the PV inverter during one day with the delaying charging period control strategy: (a) input power and (b) thermal cycle amplitude. Source: [J6].

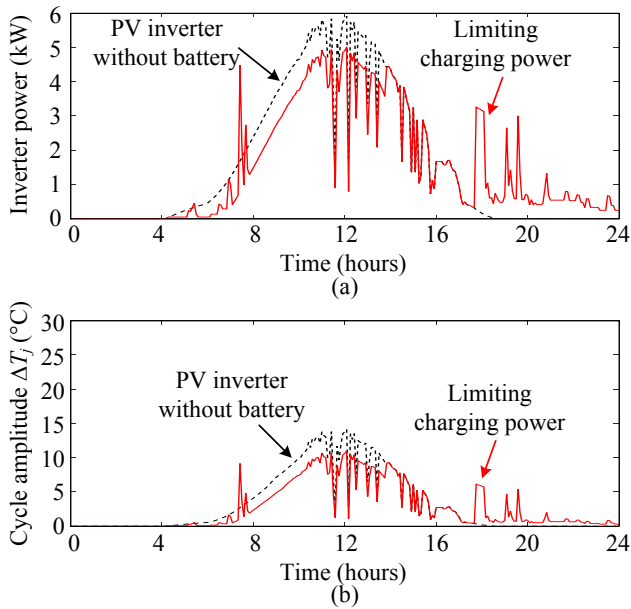

Fig. 5.12: Loading of the PV inverter during one day with the limiting charging power control strategy: (a) input power and (b) thermal cycle amplitude. Source: [J6].

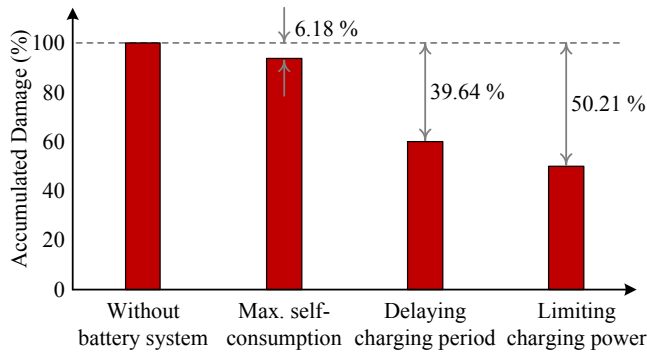

Fig. 5.13: Comparison of the accumulated damage of the power devices for different battery system control strategies. Source: [J6].

The thermal stress of the power device under different battery system control strategies is considered in the analysis. In general, the thermal stress of the power device has a similar tendency as the input power profile of the PV inverter. More specifically, the cycle amplitude of the power device decreases significantly in the early morning with the maximizing self-consumption control strategy, as it is shown in Fig. 5.10(b). In the case of the delaying charging period control strategy shown in Fig. 5.11(b), the thermal stress of the power device starts to reduce after the battery system is activated (i.e., after 9:00). For the limiting charging power control strategy, the thermal stress in the power device reduces from the early morning until the afternoon, covering the PV peak power generation period, as it is shown in Fig. 5.12(b).

The accumulated damage (AD) of the power device in the PV inverter with different battery system control strategies is summarized Fig. 5.13. It can be seen from the results that employing the maximizing self-consumption control strategy results in a comparable AD as the case without battery system. Thus, its effectiveness in terms of PV inverter reliability enhancement is limited. In contrast, the delaying charging period control strategy can reduce the AD of the power device by approximately 40 % compared to the case without batteries. Nevertheless, the limiting charging power control strategy can reduce the AD by more than 50 %, being the most effective solution in terms of the reliability enhancement of the PV inverter.

5.4 Summary

The impact of the battery system operation on the reliability of PV inverters has been analyzed in this chapter. The reliability assessment is based on the self-consumption operation where the loading of the PV inverter is modified

5.4. Summary

by the charging and discharging operation of the battery system. In general, the evaluation results have indicated that the reliability performance of the PV inverter can be improved with the battery system due to the reduced loading during the day. Moreover, the battery system parameter such as the battery capacity and battery converter power rating has also a certain impact on PV inverter reliability. Employing a battery with a large capacity and/or a small battery converter can improve the overall PV inverter reliability.

Apart from the battery system parameters, the control strategy of the battery system also plays a certain role in determining the loading and thus the reliability of the PV inverter. Three battery system control strategies to realize the self-consumption operation have been discussed in this chapter and their impact on the PV inverter reliability have been analyzed. From the PV inverter reliability perspective, employing the maximizing self-consumption control strategy results in a comparable reliability performance as the case without battery systems. The other two control strategies – delaying the battery charging period and limiting the battery charging power are more effective in terms of improving the reliability of PV inverters.

Related Publications

- C4. A. Sangwongwanich, G. Angenendt, S. Zurmühlen, Y. Yang, D. Sera, D. U. Sauer, and F. Blaabjerg, "Reliability Assessment of PV Inverters with Battery Systems Considering PV Self-Consumption and Battery Sizing," *Proc. of ECCE*, 2018, Status: Accepted.**

Main contribution:

The reliability assessment of PV inverter with battery system is discussed in this paper. The analysis is based on a one-year mission profile of PV system with the self-consumption operation. The impact of the battery system parameters (i.e., battery capacity and battery converter power rating) is also discussed.

- J6. A. Sangwongwanich, S. Zurmühlen, G. Angenendt, Y. Yang, D. Sera, D. U. Sauer, and F. Blaabjerg, "Enhancing PV Inverter Reliability with Battery System Control Strategy," *CPSS Trans. Power Electron. App.*, 2018, Status: Under Review.**

Main contribution:

In this paper, solutions to enhance the PV inverter reliability through the control of battery system are discussed. Three different control strategies for self-consumption scheme are considered, and their impact on the PV inverter loading is investigated.

Conclusions

This chapter summarizes the results and outcomes of the research during the Ph.D. study - *Grid-friendly high-reliability photovoltaic systems*. The main contributions are highlighted, and the research perspectives are discussed at the end of the chapter.

6.1 Summary

In this Ph.D. project, the main research focus is on improving the control functionality and reliability of power electronics in PV systems. Several challenging issues for the next-generation PV systems have been discussed, and the solutions to address those issues through advancing the PV inverter control have been proposed. In the following, a brief summary of this Ph.D. thesis is presented.

In *Chapter 1*, the demands and challenges for the next-generation PV systems have been discussed. In the case of a high-penetration level of PV system, the grid-integration issue is one of the major concerns, which needs to be addressed. One potential problem is related to the intermittent nature of the PV power production, which may cause several challenges to the grid such as overloading, grid voltage fluctuation, grid frequency deviation, etc. Following the recent grid-integration requirements, the flexible power control is strongly demanded to address the adverse impact from the PV systems. The solutions to fulfill these requirements have been discussed in *Chapter 2* by advancing the control of PV inverters. By modifying the Maximum Power Point Tracking (MPPT) algorithm, several active power control strategies including the power limiting control, power rate-of-change control, and power reserve control can be realized in a cost-effective way. In the case of the power reserve operation, the estimation of the available power during the

operation is also a challenge. In this Ph.D. project, two control solutions to estimate the available power during the power reserve operation have been proposed. One solution coordinates the control of different PV units, which is suitable for the multi-string PV inverter topology. The other solution is more suitable for a single PV unit (e.g., string inverter topology) where the constant power generation control and the MPPT operations are combined to routinely estimate the available power.

Another concern related to the grid-integration issue is the interharmonics generated by the PV system. As discussed in *Chapter 1*, it has been recently reported that the PV system can contribute to the interharmonics delivered to the power grid. This issue has been investigated in details in *Chapter 3*, where an in-depth analysis of the interharmonics from the grid-connected PV systems has been carried out. The analysis includes the generation mechanism of the interharmonics, where it is turned out that the MPPT perturbation is the main source that induces the interharmonics in the grid current. By understanding the generation mechanism, it was possible to model the interharmonic characteristics of the grid current according to the designed control parameters. The effectiveness of the proposed interharmonic modeling approach has been validated experimentally. Moreover, the mitigation solutions have also been explored in this Ph.D. project to address this issue.

Apart from the grid-integration challenges, reducing the cost of PV energy is another aspect which is strongly demanded in the next-generation PV system. According to the discussion in *Chapter 1*, improving the reliability of the PV inverter has high potential for a significant cost reduction of the PV systems. Therefore, the reliability of the PV inverter has been analyzed following the design for reliability approach, which is the main content of *Chapter 4*. The reliability assessment process which takes the mission profile of the PV system into consideration has been discussed. Moreover, the impact of the PV array degradation and oversizing, which can be seen as the uncertainties in the reliability evaluation, have been investigated. The degradation of the PV arrays usually leads to a continuous reduction in the PV power production. Without taking this aspect into consideration, the reliability of the PV inverter (e.g., lifetime) can be under-estimated. Oversizing the PV array is another concern, which can deviate the reliability performance of the PV inverters. While oversizing the PV arrays can increase the energy yield and has potential to reduce the cost of energy, it also increases the loading of the PV inverters, challenging their reliability. The reliability analysis of the PV inverter with oversized PV arrays has been carried out in *Chapter 4*. The evaluation results indicate that oversizing the PV arrays can significantly affect the reliability performance of the PV inverter, especially for the installation sites with relatively low solar irradiance conditions (e.g., Denmark). In that case, a certain design margin in terms of reliability is required to ensure the high-reliability of PV inverter under various PV array sizing ratios.

Although the reliability of the PV inverter can be strengthened through the design, the control strategy of the PV system can also contribute to a further improvement in the PV inverter reliability. The possibility to improve the reliability of the PV inverter through the control of the PV system with integrated battery systems is the main research focus in *Chapter 5*. Here, the residential PV system with integrated battery system was considered where the self-consumption operation is adopted. With the integrated battery system, the loading of the PV inverter is modified by the charging and discharging of the battery system. In the case of the self-consumption operation, the loading of the PV inverter is reduced, where the battery is charged by the surplus PV power. This contributes to the improvement in the reliability of the PV inverter due to the reduced stress in the components. Moreover, the control strategy of the battery system also plays an important role in modifying the loading of the PV inverter. According to the evaluation results, limiting the charging power of the battery system has a high potential to enhance the reliability of the PV inverter, where a certain amount of peak-load energy during midday is stored in the battery. In that case, the damage occurred in the components of the PV inverter (e.g., power devices) can be reduced by half compared to the case without battery systems.

6.2 Main Contributions

In this part, the main contributions of this Ph.D. project based on the research outcomes are summarized as follows:

Flexible power control of grid-connected PV systems

This Ph.D. study has proposed the cost-effective solution to realize the flexible power control functionality for PV systems through the modification of the MPPT algorithm. In that case, the extracted PV power can be regulated below the maximum available power following the demand, making the PV systems capable of providing the following power control functionalities:

- Power Limiting Control strategy
- Power Ramp-Rate Control strategy
- Power Reserve Control strategy

The developed control strategies have been implemented in the single-phase grid-connected PV systems and their performances have been validated experimentally under various operating conditions.

Analysis, modeling, and mitigation of interharmonics from grid-connected PV systems

An in-depth analysis of interharmonics from grid-connected PV systems have been carried out during the Ph.D. study. The generation mechanism of the interharmonics due to the MPPT perturbation has been investigated. The modeling approach to predict the interharmonic characteristics according to the control parameters was proposed, which can be used for the control parameters design. Moreover, mitigating solutions to minimize the interharmonics induced by the MPPT perturbation have been introduced.

Impacts of PV arrays characteristics on the reliability of PV inverters

The impacts of PV array characteristics on the reliability of the PV inverter have been investigated. The reliability assessment of the PV inverter based on the mission profile has been employed to evaluate the deviation in the reliability performance of the PV inverter considering:

- PV array degradation rates
- PV array oversizing

The obtained results can be used to identify the required design margin in terms of reliability when the PV inverter is subjected to the above conditions.

Enhancing the reliability of PV inverters with battery systems

Improving the reliability of the PV inverter is also one objective of this Ph.D. project. In that regard, the solution to enhance the reliability performance of the PV inverters through the control of the battery systems has been discussed. The impact of the battery system operation on the loading and reliability of the PV inverter has been investigated considering the following control strategies:

- Maximizing self-consumption
- Delaying charging period
- Limiting charging power

6.3 Research Perspectives

Although several aspects for grid-connected PV systems have been investigated in this Ph.D. project, there are still other challenges which need to be addressed for next-generation PV systems.

6.3. Research Perspectives

- Although this Ph.D. project proposes the flexible power control of the PV system by modifying the MPPT algorithm, there are also other solutions to achieve this requirement (e.g., by integrating the battery system). It could be more beneficial to combine different control solutions, e.g., optimally coordinate the operation between the battery system and the modifying MPPT algorithm, to reduce the overall cost while maintaining the energy yield at a high level.
- The analysis of interharmonics from the PV system addressed in this study only considers single-phase PV systems. Moreover, the topology used in the study is limited to the full-bridge inverter and only the Perturb and Observe (P&O) MPPT algorithm is discussed. It could be interesting to extend the modeling approach in this study to other PV system configurations, system topologies, operating conditions, and MPPT algorithms. In that case, it can be pointed out which aspect has higher impact on the interharmonic characteristic of the PV systems.
- The impacts of the PV array characteristic (e.g., degradation rates, over-sizing) have been analyzed through simulations in this Ph.D. project. However, the experimental validation regarding the thermal loading and, possibly, the reliability performance of the components in the inverter have not been carried out. It could be interesting to investigate those variations in the operating condition of the PV inverter experimentally under a real mission profile both in a controlled environment and field operation.
- Regarding the integration of the battery system, only the reliability and lifetime of the PV inverters have been discussed. In fact, the battery is also a component that is prone to failure during the operation. Thus, a more system-level analysis including the reliability of the PV inverter and battery system is required to ensure the reliability performance of the entire system.
- The reliability analysis in this Ph.D. project can be further employed in the cost optimization tool, e.g., cost of energy, during the lifespan of PV system. For instance, the repair rate and the associated cost due to the inverter downtime should be taken into consideration in the cost analysis based on the reliability performance of the PV inverter.

Besides the above aspects, the power electronics technology is also developing at a fast pace. New components, topologies, and control methods are continuously investigating. It is always important to be able to cope with the new technologies and ensure that the methodology discussed in this Ph.D. project can still be applied. Otherwise, certain modifications should be addressed to fulfill the requirements of the next-generation PV systems.

References

- [1] National Renewable Energy Laboratory, "On the path to sunshot: The role of advancements in solar photovoltaic efficiency, reliability, and costs," Tech. Rep. No. NREL/TP-6A20-65872, 2016.
- [2] D. C. Jordan, J. H. Wohlgemuth, and S. R. Kurtz, "Technology and climate trends in PV module degradation," in *Proc. Eur. Photovolt. Sol. Energy Conf. Exhib.*, pp. 3118–3124, Sep. 2012.
- [3] A. Meisel, A. Mayer, S. Beyene, J. Hewlett, K. N. Maxwell, N. Coleman, F. Dross, C. Bordonaro, J. Meydbray, and E. Mayo, "Solarcity photovoltaic modules with 35 year useful life," 2016.
- [4] E. Reiter, K. Ardani, R. Margolis, and R. Edge, "Industry perspectives on advanced inverters for us solar photovoltaic systems: Grid benefits, deployment challenges, and emerging solutions," National Renewable Energy Laboratory (NREL), Tech. Rep., 2015.
- [5] F. Katiraei and J. R. Aguero, "Solar PV integration challenges," *IEEE Power Energy Mag.*, vol. 9, no. 3, pp. 62–71, May 2011.
- [6] C. Sintamarean, E. Eni, F. Blaabjerg, R. Teodorescu, and H. Wang, "Wide-band gap devices in PV systems - opportunities and challenges," in *Proc. of IPEC - ECCE ASIA*, pp. 1912–1919, May 2014.
- [7] R. Inzunza, R. Okuyama, T. Tanaka, and M. Kinoshita, "Development of a 1500Vdc photovoltaic inverter for utility-scale PV power plants," in *Proc. of IFEEC*, pp. 1–4, Nov. 2015.
- [8] L. M. Moore and H. N. Post, "Five years of operating experience at a large, utility-scale photovoltaic generating plant," *Progress Photovoltaics: Res. Appl.*, vol. 16, no. 3, pp. 249–259, 2008.
- [9] P. Hacke, S. Lokanath, P. Williams, A. Vasan, P. Sochor, G. Tamizhmani, H. Shinohara, and S. Kurtz, "A status review of photovoltaic power conversion equipment reliability, safety, and quality assurance protocols," *Renewable and Sustainable Energy Reviews*, vol. 82, pp. 1097 – 1112, 2018.
- [10] J. von Appen, M. Braun, T. Stetz, K. Diwold, and D. Geibel, "Time in the sun: The challenge of high PV penetration in the German electric grid," *IEEE Power and Energy Mag.*, vol. 11, no. 2, pp. 55–64, Mar. 2013.
- [11] Y. Yang, P. Enjeti, F. Blaabjerg, and H. Wang, "Wide-scale adoption of photovoltaic energy: Grid code modifications are explored in the distribution grid," *IEEE Ind. Appl. Mag.*, vol. 21, no. 5, pp. 21–31, Sep. 2015.

References

- [12] T. Stetz, J. von Appen, F. Niedermeyer, G. Scheibner, R. Sikora, and M. Braun, "Twilight of the grids: The impact of distributed solar on Germany's energy transition," *IEEE Power and Energy Mag.*, vol. 13, no. 2, pp. 50–61, Mar. 2015.
- [13] A. Woyte, V. V. Thong, R. Belmans, and J. Nijs, "Voltage fluctuations on distribution level introduced by photovoltaic systems," *IEEE Trans. Energy Convers.*, vol. 21, no. 1, pp. 202–209, Mar. 2006.
- [14] S. Shivashankar, S. Mekhilef, H. Mokhlis, and M. Karimi, "Mitigating methods of power fluctuation of photovoltaic (PV) sources - a review," *Renewable and Sustainable Energy Reviews*, vol. 59, pp. 1170 – 1184, 2016.
- [15] B. Kroposki, "Can solar save the grid?" *IEEE Spectrum*, vol. 53, no. 11, pp. 42–47, Nov. 2016.
- [16] Energinet.dk, "Technical regulation 3.2.2 for PV power plants with a power output above 11 kW," Tech. Rep. Doc. 14/17997-39, 2016.
- [17] T. Stetz, F. Marten, and M. Braun, "Improved low voltage grid-integration of photovoltaic systems in Germany," *IEEE Trans. Sustain. Energy*, vol. 4, no. 2, pp. 534–542, Apr. 2013.
- [18] BDEW, "Technische richtlinie erzeugungsanlagen am mittelspannungsnetz – richtlinie für anschluss und parallelbetrieb von erzeugungsanlagen am mittelspannungsnetz," Jun. 2008.
- [19] E. Troester, "New German grid codes for connecting PV systems to the medium voltage power grid," in *Proc. of 2nd Int. Workshop Concentrating Photovoltaic Power Plants: Opt. Design, Prod., Grid Connection*, 2009.
- [20] V. Gevorgian and S. Booth, "Review of PREPA technical requirements for interconnecting wind and solar generation," National Renewable Energy Laboratory (NREL), Tech. Rep., 2013.
- [21] European Network of Transmission System Operators for Electricity, "Network code for requirements for grid connection applicable to all generators," Tech. Rep., Mar. 2013.
- [22] A. R. Oliva and J. C. Balda, "A PV dispersed generator: a power quality analysis within the IEEE 519," *IEEE Trans. Power Del.*, vol. 18, no. 2, pp. 525–530, Apr. 2003.
- [23] D. G. Infield, P. Onions, A. D. Simmons, and G. A. Smith, "Power quality from multiple grid-connected single-phase inverters," *IEEE Trans. Power Del.*, vol. 19, no. 4, pp. 1983–1989, Oct. 2004.

- [24] D. Gallo, R. Langella, A. Testa, J. C. Hernandez, I. Papic, B. Blazic, and J. Meyer, "Case studies on large PV plants: Harmonic distortion, unbalance and their effects," in *Proc. IEEE Power Energy Soc. General Meeting*, pp. 1–5, Jul. 2013.
- [25] Y. Du, D. D.-C. Lu, G. James, and D. J. Cornforth, "Modeling and analysis of current harmonic distortion from grid connected PV inverters under different operating conditions," *Solar Energy*, vol. 94, pp. 182–194, Aug. 2013.
- [26] Y. Yang, K. Zhou, and F. Blaabjerg, "Current harmonics from single-phase grid-connected inverters - examination and suppression," *IEEE J. Emerg. Sel. Top. Power Electron.*, vol. 4, no. 1, pp. 221–233, Mar. 2016.
- [27] A. Testa, M. F. Akram, R. Burch, G. Carpinelli, G. Chang, V. Dinavahi, C. Hatziaadoniu, W. M. Grady, E. Gunther, M. Halpin, P. Lehn, Y. Liu, R. Langella, M. Lowenstein, A. Medina, T. Ortmeier, S. Ranade, P. Ribeiro, N. Watson, J. Wikston, and W. Xu, "Interharmonics: Theory and modeling," *IEEE Trans. Power Del.*, vol. 22, no. 4, pp. 2335–2348, Oct. 2007.
- [28] M. R. Rifai, T. H. Ortmeier, and W. J. McQuillan, "Evaluation of current interharmonics from AC drives," *IEEE Trans. Power Del.*, vol. 15, no. 3, pp. 1094–1098, Jul. 2000.
- [29] F. D. Rosa, R. Langella, A. Sollazzo, and A. Testa, "On the interharmonic components generated by adjustable speed drives," *IEEE Trans. Power Del.*, vol. 20, no. 4, pp. 2535–2543, Oct. 2005.
- [30] H. Soltani, F. Blaabjerg, F. Zare, and P. C. Loh, "Effects of passive components on the input current interharmonics of adjustable-speed drives," *IEEE J. Emerg. Sel. Top. Power Electron.*, vol. 4, no. 1, pp. 152–161, Mar. 2016.
- [31] L. F. Beites, J. G. Mayordomo, A. Hernandez, and R. Asensi, "Harmonics, interharmonics and unbalances of arc furnaces: a new frequency domain approach," *IEEE Trans. Power Del.*, vol. 16, no. 4, pp. 661–668, Oct. 2001.
- [32] C. Vilar, J. Usaola, and H. Amaris, "A frequency domain approach to wind turbines for flicker analysis," *IEEE Trans. Energy Convers.*, vol. 18, no. 2, pp. 335–341, Jun. 2003.
- [33] R. Langella, A. Testa, S. Z. Djokic, J. Meyer, and M. Klatt, "On the interharmonic emission of PV inverters under different operating conditions," in *Proc. ICHQP*, pp. 733–738, Oct. 2016.

References

- [34] R. Langella, A. Testa, J. Meyer, F. Möller, R. Stiegler, and S. Z. Djokic, "Experimental-based evaluation of PV inverter harmonic and interharmonic distortion due to different operating conditions," *IEEE Trans. Instrum. Meas.*, vol. 65, no. 10, pp. 2221–2233, Oct. 2016.
- [35] P. Pakonen, A. Hilden, T. Suntio, and P. Verho, "Grid-connected PV power plant induced power quality problems - experimental evidence," in *Proc. EPE*, pp. 1–10, Sep. 2016.
- [36] G. Petrone, G. Spagnuolo, R. Teodorescu, M. Veerachary, and M. Vitelli, "Reliability issues in photovoltaic power processing systems," *IEEE Trans. Ind. Electron.*, vol. 55, no. 7, pp. 2569–2580, Jul. 2008.
- [37] A. Golnas, "PV system reliability: An operator's perspective," *IEEE J. of Photovolt.*, vol. 3, no. 1, pp. 416–421, Jan. 2013.
- [38] H. Wang, M. Liserre, and F. Blaabjerg, "Toward reliable power electronics: Challenges, design tools, and opportunities," *IEEE Ind. Electron. Mag.*, vol. 7, no. 2, pp. 17–26, Jun. 2013.
- [39] K. Ma, H. Wang, and F. Blaabjerg, "New approaches to reliability assessment: Using physics-of-failure for prediction and design in power electronics systems," *IEEE Power Electron. Mag.*, vol. 3, no. 4, pp. 28–41, Dec. 2016.
- [40] Enphase Energy, "Reliability study of electrolytic capacitors in a microinverter," Sep. 2008. [Online]. Available: <http://enphase.com/sites/default/files/EnphaseElectrolyticCapacitorLife.pdf>
- [41] Y. Song and B. Wang, "Survey on reliability of power electronic systems," *IEEE Trans. Power Electron.*, vol. 28, no. 1, pp. 591–604, Jan. 2013.
- [42] SolarEdge, "Oversizing of SolarEdge inverters, technical note," Tech. Rep., Jul. 2016. [Online]. Available: http://www.solaredge.com/sites/default/files/inverter_dc_oversizing_guide.pdf
- [43] F. Blaabjerg, R. Teodorescu, M. Liserre, and A.V. Timbus, "Overview of control and grid synchronization for distributed power generation systems," *IEEE Trans. Ind. Electron.*, vol. 53, no. 5, pp. 1398–1409, Oct. 2006.
- [44] N. Femia, G. Petrone, G. Spagnuolo, and M. Vitelli, *Power electronics and control techniques for maximum energy harvesting in photovoltaic systems*. CRC press, 2012.
- [45] S.B. Kjaer, J.K. Pedersen, and F. Blaabjerg, "A review of single-phase grid-connected inverters for photovoltaic modules," *IEEE Trans. Ind. Appl.*, vol. 41, no. 5, pp. 1292–1306, Sep. 2005.

- [46] Y. Yang and F. Blaabjerg, "Overview of single-phase grid-connected photovoltaic systems," *Electr. Power Componen. and Syst.*, vol. 43, no. 12, pp. 1352–1363, 2015.
- [47] A. Hoke, E. Muljadi, and D. Maksimovic, "Real-time photovoltaic plant maximum power point estimation for use in grid frequency stabilization," in *Proc. of COMPEL*, pp. 1–7, Jul. 2015.
- [48] B. I. Craciun, T. Kerekes, D. Sera, and R. Teodorescu, "Frequency support functions in large PV power plants with active power reserves," *IEEE J. Emerg. Sel. Topics Power Electron.*, vol. 2, no. 4, pp. 849–858, Dec. 2014.
- [49] S. Nanou, A. Papakonstantinou, and S. Papathanassiou, "Control of a PV generator to maintain active power reserves during operation," in *Proc. of EU PVSEC*, pp. 4059–4063, 2012.
- [50] H. Xin, Z. Lu, Y. Liu, and D. Gan, "A center-free control strategy for the coordination of multiple photovoltaic generators," *IEEE Trans. Smart Grid.*, vol. 5, no. 3, pp. 1262–1269, May 2014.
- [51] E. I. Batzelis, G. E. Kampitsis, and S. A. Papathanassiou, "Power reserves control for PV systems with real-time MPP estimation via curve fitting," *IEEE Trans. Sustain. Energy*, vol. 8, no. 3, pp. 1269–1280, Jul. 2017.
- [52] M. Nijhuis, B. Rawn, and M. Gibescu, "Prediction of power fluctuation classes for photovoltaic installations and potential benefits of dynamic reserve allocation," *IET Renewable Power Generation*, vol. 8, no. 3, pp. 314–323, Apr. 2014.
- [53] V. Blasko and V. Kaura, "A new mathematical model and control of a three-phase AC-DC voltage source converter," *IEEE Trans. Power Electron.*, vol. 12, no. 1, pp. 116–123, Jan. 1997.
- [54] N. Femia, G. Petrone, G. Spagnuolo, and M. Vitelli, "Optimization of perturb and observe maximum power point tracking method," *IEEE Trans. Power Electron.*, vol. 20, no. 4, pp. 963–973, Jul. 2005.
- [55] T. Eram and P.L. Chapman, "Comparison of photovoltaic array maximum power point tracking techniques," *IEEE Trans. Energy Convers.*, vol. 22, no. 2, pp. 439–449, Jun. 2007.
- [56] H. Huang and P. A. Mawby, "A lifetime estimation technique for voltage source inverters," *IEEE Trans. Power Electron.*, vol. 28, no. 8, pp. 4113–4119, Aug. 2013.

References

- [57] M. Musallam, C. Yin, C. Bailey, and M. Johnson, "Mission profile-based reliability design and real-time life consumption estimation in power electronics," *IEEE Trans. Power Electron.*, vol. 30, no. 5, pp. 2601–2613, May 2015.
- [58] S. E. D. Leon-Aldaco, H. Calleja, F. Chan, and H. R. Jimenez-Grajales, "Effect of the mission profile on the reliability of a power converter aimed at photovoltaic applications - a case study," *IEEE Trans. Power Electron.*, vol. 28, no. 6, pp. 2998–3007, Jun. 2013.
- [59] Y. Yang, H. Wang, F. Blaabjerg, and K. Ma, "Mission profile based multi-disciplinary analysis of power modules in single-phase transformerless photovoltaic inverters," in *Proc. of EPE*, pp. 1–10, Sep. 2013.
- [60] J. M. Lenz, H. C. Sartori, and J. R. Pinheiro, "Mission profile characterization of PV systems for the specification of power converter design requirements," *Solar Energy*, vol. 157, pp. 263 – 276, 2017.
- [61] H. Wang and F. Blaabjerg, "Reliability of capacitors for dc-link applications in power electronic converters - an overview," *IEEE Trans. Ind. App.*, vol. 50, no. 5, pp. 3569–3578, Sep. 2014.
- [62] P. D. Reigosa, H. Wang, Y. Yang, and F. Blaabjerg, "Prediction of bond wire fatigue of IGBTs in a PV inverter under a long-term operation," *IEEE Trans. Power Electron.*, vol. 31, no. 10, pp. 7171–7182, Oct. 2016.
- [63] M. Ciappa, "Selected failure mechanisms of modern power modules," *Microelectronics Reliability*, vol. 42, no. 4, pp. 653 – 667, 2002.
- [64] U. Scheuermann, R. Schmidt, and P. Newman, "Power cycling testing with different load pulse durations," in *Proc. of PEMD 2014*, pp. 1–6, Apr. 2014.
- [65] E. L. Meyer and E. E. van Dyk, "Assessing the reliability and degradation of photovoltaic module performance parameters," *IEEE Trans. Rel.*, vol. 53, no. 1, pp. 83–92, Mar. 2004.
- [66] M. Vazquez and I. Rey-Stolle, "Photovoltaic module reliability model based on field degradation studies," *Progress Photovoltaics: Res. Appl.*, vol. 16, no. 5, pp. 419–433, 2008.
- [67] V. Sharma and S. Chandel, "Performance and degradation analysis for long term reliability of solar photovoltaic systems: A review," *Renewable and Sustainable Energy Reviews*, vol. 27, pp. 753–767, 2013.
- [68] D. C. Jordan and S. R. Kurtz, "Photovoltaic degradation rates - an analytical review," *Progress Photovoltaics: Res. Appl.*, vol. 21, no. 1, pp. 12–29, 2013.

- [69] J. Fiorelli and M. Zuercher-Martinson, "How oversizing your array-to-inverter ratio can improve solar-power system performance," *Solar Power World*, vol. 7, pp. 42–48, 2013.
- [70] T. Khatib, A. Mohamed, and K. Sopian, "A review of photovoltaic systems size optimization techniques," *Renew. Sustain. Energy Rev.*, vol. 22, pp. 454–465, 2013.
- [71] M. Hussin, A. Omar, S. Shaari, and N. M. Sin, "Review of state-of-the-art: Inverter-to-array power ratio for thin-film sizing technique," *Renewable and Sustainable Energy Reviews*, vol. 74, pp. 265–277, 2017.
- [72] Global Sustainable Energy Solutions (GSES) India, "Oversizing PV arrays," Tech. Rep., 2014.
- [73] J. Good and J. X. Johnson, "Impact of inverter loading ratio on solar photovoltaic system performance," *Applied Energy*, vol. 177, pp. 475–486, Sep. 2016.
- [74] D. C. Jordan, S. R. Kurtz, K. VanSant, and J. Newmiller, "Compendium of photovoltaic degradation rates," *Progress in Photovoltaics: Res. Appl.*, vol. 24, no. 7, pp. 978–989, 2016.
- [75] M. Köntges, S. Altmann, T. Heimberg, U. Jahn, and K. A. Berger, "Mean degradation rates in pv systems for various kinds of pv module failures," in *Proc. of EU PVSEC*, pp. 1435–1443, Jun. 2016.
- [76] K. J. Sauer, "Real-world challenges and opportunities in degradation rate analysis for commercial PV systems," in *Proc. of PVSC*, pp. 003 208–003 212, Jun. 2011.
- [77] J. Hedström and L. Palmblad, "Performance of old PV modules: measurement of 25 years old crystalline silicon modules," *Elforsk Rapport 06*, vol. 71, 2006.
- [78] Y. Tang, B. Raghuraman, J. Kuitche, G. TamizhMani, C. E. Backus, and C. Osterwald, "An evaluation of 27+ years old photovoltaic modules operated in a hot-desert climatic condition," in *Proc. of 4th World Conf. Photovoltaic Energy Convers.*, vol. 2, pp. 2145–2147, May 2006.
- [79] S. Spataru, P. Cernek, D. Sera, T. Kerekes, and R. Teodorescu, "Characterization of a crystalline silicon photovoltaic system after 15 years of operation in northern Denmark," in *Proc. of EU PVSEC*, pp. 2680–2688, 2014.
- [80] SMA, "7 reasons why you should oversize your PV array," Dec. 2015. [Online]. Available: <http://en.sma-sunny.com/en/7-reasons-why-you-should-oversize-your-pv-array-2/>

References

- [81] National Renewable Energy Laboratory, "The role of energy storage with renewable electricity generation," Tech. Rep. No. NREL/TP-6A2-47187, 2010.
- [82] S. Zurmühlen, G. Angenendt, M. Heinrich, H. Axelsen, and D. U. Sauer, "Grid-relieving effects of PV battery energy storage systems with optimized operation strategies," in *Proc. of EU PVSEC*, pp. 1–5, Sep. 2017.
- [83] IRENA, "Boosting solar PV markets: The role of quality infrastructure," 2017. [Online]. Available: <http://www.irena.org/>.
- [84] J. Weniger, T. Tjaden, and V. Quaschnig, "Sizing of residential PV battery systems," in *Proc. of IRES*, pp. 78–87, 2013.
- [85] G. Merei, J. Moshövel, D. Magnor, and D. U. Sauer, "Optimization of self-consumption and techno-economic analysis of PV-battery systems in commercial applications," *Applied Energy*, vol. 168, pp. 171–178, 2016.
- [86] M. Resch, B. Ramadhani, J. Bühler, and A. Sumper, "Comparison of control strategies of residential PV storage systems," in *Proc. of IRES*, pp. 1–18, Mar. 2015.
- [87] J. Moshövel, K.-P. Kairies, D. Magnor, M. Leuthold, M. Bost, S. Gähns, E. Szczechowicz, M. Cramer, and D. U. Sauer, "Analysis of the maximal possible grid relief from PV-peak-power impacts by using storage systems for increased self-consumption," *Applied Energy*, vol. 137, pp. 567–575, 2015.
- [88] D. Magnor, J. B. Gerschler, M. Ecker, P. Merk, and D. U. Sauer, "Concept of a battery aging model for lithium-ion batteries considering the lifetime dependency on the operation strategy," in *Proc. of EU PVSEC*, vol. 24, 2009.
- [89] M. Schneider, P. Boras, H. Schaede, L. Quurck, and S. Rinderknecht, "Effects of operational strategies on performance and costs of electric energy storage systems," *Energy Procedia*, vol. 46, pp. 271–280, 2014.
- [90] A. Zeh and R. Witzmann, "Operational strategies for battery storage systems in low-voltage distribution grids to limit the feed-in power of roof-mounted solar power systems," *Energy Procedia*, vol. 46, pp. 114–123, 2014.

ISSN (online): 2446-1636
ISBN (online): 978-87-7210-215-3

AALBORG UNIVERSITY PRESS