



Aalborg Universitet

AALBORG UNIVERSITY
DENMARK

Adaptive TS Fuzzy-based MPC for DC Microgrids with Dynamic CPLs

Nonlinear Power Observer Approach

Vafamand, Navid; Yousefizadeh, Shirin; Khooban, Mohammad Hassan; Bendtsen, Jan Dimon; Dragicevic, Tomislav

Published in:
I E E Systems Journal

DOI (link to publication from Publisher):
[10.1109/JSYST.2018.2880135](https://doi.org/10.1109/JSYST.2018.2880135)

Publication date:
2019

Document Version
Accepted author manuscript, peer reviewed version

[Link to publication from Aalborg University](#)

Citation for published version (APA):
Vafamand, N., Yousefizadeh, S., Khooban, M. H., Bendtsen, J. D., & Dragicevic, T. (2019). Adaptive TS Fuzzy-based MPC for DC Microgrids with Dynamic CPLs: Nonlinear Power Observer Approach. *I E E Systems Journal*, 13(3), 3203-3210. Article 8552394. Advance online publication. <https://doi.org/10.1109/JSYST.2018.2880135>

General rights

Copyright and moral rights for the publications made accessible in the public portal are retained by the authors and/or other copyright owners and it is a condition of accessing publications that users recognise and abide by the legal requirements associated with these rights.

- Users may download and print one copy of any publication from the public portal for the purpose of private study or research.
- You may not further distribute the material or use it for any profit-making activity or commercial gain
- You may freely distribute the URL identifying the publication in the public portal -

Take down policy

If you believe that this document breaches copyright please contact us at vbn@aub.aau.dk providing details, and we will remove access to the work immediately and investigate your claim.

Adaptive TS Fuzzy-Based MPC for DC Microgrids With Dynamic CPLs: Nonlinear Power Observer Approach

Navid Vafamand ¹, Shirin Yousefizadeh, Mohammad Hassan Khooban ², *Senior Member, IEEE*, Jan Dimon Bendtsen, *Member, IEEE*, and Tomislav Dragičević ³, *Senior Member, IEEE*

Abstract—The performance of a DC microgrid (MG) might degrade because of the dynamics of constant power loads (CPLs). In this paper, a novel adaptive controller is proposed to mitigate the destructive effect of time-varying uncertain CPLs. A nonlinear disturbance observer is developed to estimate the instantaneous power of the CPLs. The estimated CPLs powers are then employed in a Takagi–Sugeno fuzzy-based model predictive control strategy, aiming to adaptively modify the injecting current of the energy storage system. The proposed approach is applied to a dc MG testbed that feeds one CPL. Experimental results show that the proposed adaptive controller is able to increase the stability margin and improve the transient response of the dc MG.

Index Terms—DC microgrid (MG), model predictive controller (MPC), non-ideal constant power load (CPL), nonlinear power observer, Takagi–Sugeno (TS) fuzzy model.

NOMENCLATURE

CPL	Constant power load.
ESS	Energy storage system.
MG	Microgrid.
MPC	Model predictive control.
NDOB	Nonlinear disturbance observer.
TS	Takagi–Sugeno.
$i_{L,j}$	Current of the inductor in the j th CPL.
$v_{C,j}$	Voltage of the capacitor in the j th CPL.
P_j	The power of the j th CPL.
r_j	Resistance of the j th filter connected to the j th CPL.
L_j	Inductance of the j th filter connected to the j th CPL.
C_j	Capacitance of the j th filter connected to the j th CPL.
r_s	Resistance of the filter connected to the dc source.

L_s	Inductance of the filter connected to the dc source.
C_s	Capacitance of the filter connected to the dc source.
V_{dc}	Voltage of the dc source.
i_{es}	Injecting current of the ESS.
z	Internal state vector.
\hat{P}	Estimation of the power of the CPLs.
L_o	Gain matrix.
s	Auxiliary vector.
X	Augmented state vector of the dc MG.
x_k	State vector in a discrete-time representation.
y_k	Output vector in a discrete-time representation.
h_i	The i th normalized membership function.
A_i, B_i, E_i, C_i	Local TS fuzzy matrices.
A_h, B_h, E_h, C_h	Nonlinear TS fuzzy matrices.
$\hat{y}_{k j}$	Output prediction at sampling instant k based on the information up to the sampling instant j .
J	Cost function.
W	Future reference of the system.
Θ, Δ	Adaptive matrices of the MPC.
U	Sequence of the future control input vector.

I. INTRODUCTION

AN MG is an electrical grid unit that is able to generate power, distribute it through a network, as well as control and monitor the distributed power to connected loads. MGs can operate in both grid-connected and islanded modes [1]–[3]. DC MGs are more suitable than ac MGs when it comes to providing power to dc loads, as well as integrating renewable energy sources and ESSs [4]. The advantages and challenges of dc MGs are described in [5]. DC MGs usually include several converters to ensure that the power requirements of the sources and loads are met. However, experience shows that tightly regulated dc converters connected to the loads make them behave as CPLs. The negative incremental impedance characteristics of CPLs may cause system instability and degradation. Therefore, minimizing the destabilizing effect of the CPLs is a requirement to

Manuscript received April 17, 2018; revised September 26, 2018; accepted November 4, 2018. (*Corresponding author: Mohammad Hassan Khooban.*)

N. Vafamand, M. H. Khooban, and T. Dragičević are with the Department of Energy Technology, Aalborg University, Aalborg 9220, Denmark (e-mail: nav@et.aau.dk; mhkhoban@gmail.com; tdr@et.aau.dk).

S. Yousefizadeh and J. D. Bendtsen are with the Department of Electronic Systems, Aalborg University, Aalborg 9220, Denmark (e-mail: shy@es.aau.dk; dimon@es.aau.dk).

Digital Object Identifier 10.1109/JSYST.2018.2880135

control the dc MG efficiently. The nonlinear nature of dc MGs with CPLs necessitates using nonlinear control strategies to mitigate undesired effects of CPLs [6]–[8], and to determine stability requirements [9]. In [6], a linear state-feedback controller is designed to ensure system stability. Then, the injecting power is tuned based on the obtained control law. In [7], a linear system is first obtained by means of a linearizing state feedback. Then, a proportional-derivative controller is utilized for pole placement. In [8], a diffeomorphism change of variable is presented to facilitate applying a backstepping controller which depends on the second time derivative of the desired reference. The main drawback of [5] and [6] is that derivative terms appear in their control laws, which amplifies noises. Hence, these approaches are unable to completely cancel the CPL dynamics in the presence of noise [9]. In [10], Lipchitz techniques are deployed to obtain a quasi-linear system from the nonlinear CPL dynamics. Then, the obtained system is controlled by a robust linear controller. A common assumption in the aforementioned approaches is that they all assume ideal CPLs. However, in practical applications, the MGs feed uncertain and/or time-varying CPLs, which are known as non-ideal CPLs. A few research works have studied the non-ideal CPLs effect in the stability analysis [11]–[13]. In [11], by constructing a linear fractional transformation of an uncertain MG, a μ -synthesis is used to calculate the maximum upper bound of system uncertainties to guarantee system stability. In [12], sufficient stability conditions are derived in terms of linear matrix inequalities (LMIs) under the assumption that the unknown powers of CPLs are bounded by some pre-given limits. Authors in [13] have proposed a sliding mode controller to stabilize an MG containing uncertain CPLs by employing an energy storage unit. Even though authors in [11]–[13] investigate the stability analysis and provide robust controller designs, they all assume that the uncertainty in the power load is bounded by a known limit. In order to overcome the considered limit on this uncertainty, instantaneous power estimation of the time-varying uncertain CPLs is necessary. The two main approaches for unknown parameter estimation are deterministic observers (DOB) and stochastic estimators. Even though stochastic estimators, such as Kalman filtering and its derivatives, are proved to be tolerant against process and measurement noises, they do not guarantee that state estimates actually converge to the true values. In contrast, DOBs guarantee the convergence of state estimations to the vicinity of actual states [14]. DOBs treat the instantaneous power of the CPL as an unknown disturbance. It is estimated by modifying the estimation using the difference between the estimated output and the output of a nominal model. The extension of the DOB for nonlinear systems is a NDOB [15]. A comprehensive review on DOBs and NDOBs can be found in [16]. Thereafter, to compensate for the CPL undesired effect, an online adaptive controller is needed to regulate the injecting current of the ESS complying with the CPL estimated power. MPC is an effective control strategy that predicts the future behavior of a system over a specific prediction horizon [17], [18]. The MPC's control law is obtained by optimizing a cost function over the prediction horizon at each time step. The online calculation can be carried out by quadratic optimization or other numerical techniques such as LMI solvers [19].

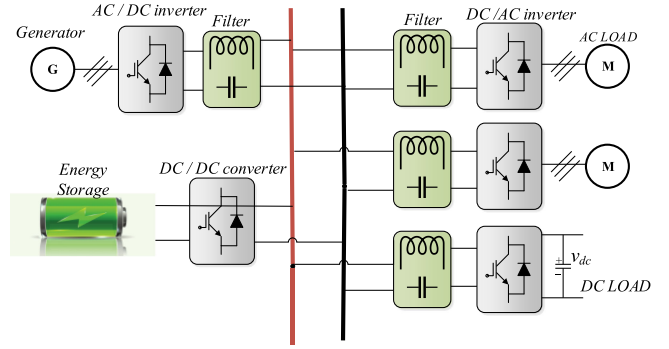

Fig. 1. Illustration of the used DC MG in electric aircraft, navy ships, automotive, etc.

Nonlinear MPC techniques can be formulated in terms of LMIs by considering TS fuzzy model representations [19]–[21].

In this paper, a novel adaptive controller is employed to stabilize a dc MG connected to an uncertain time-varying CPL. The proposed approach first utilizes an NDOB to estimate the instantaneous power of the CPL. The estimated power is then used in a TS fuzzy model-based MPC to optimally modify the ESS injection current. The proposed approach is robust against the power variations in the non-ideal or time-varying CPLs and it can effectively stabilize the dc MG within a wide range of variations of the power. Comparing with the state-of-the-art methods in which a robust viewpoint to handle the non-ideal CPLs is utilized, the proposed approach presents an adaptive scheme, which yields a better transient performance and less battery power consumption. The merits of the proposed approach are verified by experiments.

This paper is organized as follows: in Section II, the overall nonlinear state-space model of the studied dc MG is presented. In Section II, the proposed nonlinear power observer along with a proof of convergence is discussed. In Section III, the proposed adaptive TS-based MPC is provided and the value of the injecting current is systematically designed. Then, in Section IV, the experimental results are given to illustrate the effectiveness of the proposed approach in practice. Finally, Section V concludes this paper.

II. DC MG DYNAMICS

The considered dc MG, which contains several CPLs, is shown in Fig. 1, and its simplified illustration is shown in Fig. 4. To derive the overall system dynamic, initially, one CPL and one source are studied.

The j th CPL subsystem and the source subsystem in Fig. 1 are shown in Figs. 2 and 3, respectively.

The dynamic equation of the j th CPL subsystem is obtained as [22]

$$\begin{cases} \dot{i}_{L,j} = -\frac{r_{L,j}}{L_j} i_{L,j} - \frac{1}{L} v_{C,j} + \frac{1}{L_j} V_{dc} \\ \dot{v}_{C,j} = \frac{1}{C_j} i_{L,j} - \frac{1}{C_j} \frac{P_j}{v_{c,j}} \end{cases} \quad (1)$$

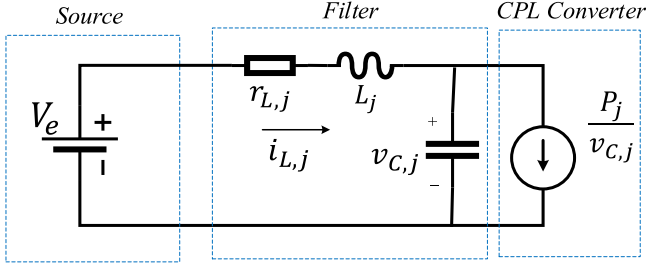
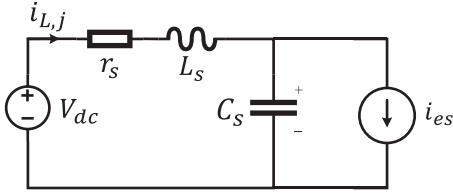
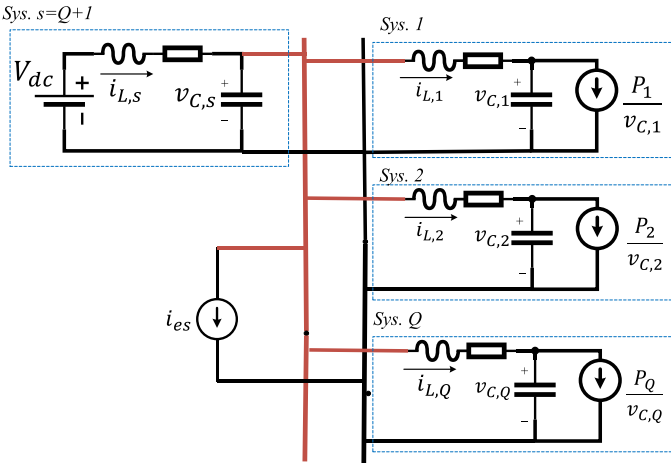

 Fig. 2. Simplification of the j th source and power converter load as a CPL.

Fig. 3. Simplification of the ESS.

 Fig. 4. Simplified illustration of the DC MG shown in Fig. 1 with Q CPLs.

where P_j is the power of the j th CPL. Also, the source dynamics can be written as [3]

$$\begin{cases} \dot{i}_{L,s} = -\frac{r_s}{L_s} i_{L,s} - \frac{1}{L_s} v_{C,s} + \frac{1}{L_s} V_{dc} \\ \dot{v}_{C,s} = \frac{1}{C_s} i_{L,s} - \frac{1}{C_s} v_{C,s} - \frac{1}{C_s} i_{es} \end{cases} \quad (2)$$

where i_{es} is the ESS injection current. The dynamic equations of the overall MG, which consist of multiple CPLs and energy storages connected to the source as shown in Fig. 4, can be obtained by extending the dynamic equations calculation procedure for the MG with one CPL and one source. As is evident from Fig. 4, the overall MG system can be decoupled into $Q + 1$ subsystems (i.e., Q CPLs and one source).

The state-space equations of the CPLs ($1, \dots, Q$) are of the form [23]

$$\begin{cases} \dot{x}_j = A_j x_j + d_j P_j + A_{j,s} x_s \\ y_j = x_j \end{cases} \quad (3)$$

where $x_j = [i_{L,j} \ v_{C,j}]^T$ is the CPL state vector and

$$A_j = \begin{bmatrix} -\frac{r_{L,j}}{L_j} & -\frac{1}{L_j} \\ \frac{1}{C_j} & 0 \end{bmatrix}, \quad d_j = \begin{bmatrix} 0 \\ -1 \\ \frac{1}{C_j v_{C,j}} \end{bmatrix}, \quad A_{j,s} = \begin{bmatrix} 0 & \frac{1}{L_j} \\ 0 & 0 \end{bmatrix}. \quad (4)$$

The state-space equations of the source subsystem can be written as

$$\begin{cases} \dot{x}_s = A_s x_s + b_s V_{dc} + b_e i_{es} + \sum_{j=1}^Q A_{cn} x_j \\ y_s = x_s \end{cases} \quad (5)$$

where $x_s = [i_{L,s} \ v_{C,s}]^T$ is the source state vector and

$$A_s = \begin{bmatrix} -\frac{r_s}{L_s} & -\frac{1}{L_s} \\ \frac{1}{C_s} & 0 \end{bmatrix}, \quad A_{cn} = \begin{bmatrix} 0 & 0 \\ -1 & 0 \\ \frac{1}{C_s} & 0 \end{bmatrix}, \quad b_s = \begin{bmatrix} \frac{1}{L_s} & 0 \end{bmatrix}^T, \quad b_{es} = \begin{bmatrix} 0 & -\frac{1}{C_s} \end{bmatrix}^T. \quad (6)$$

By augmenting the CPLs and the sources state vectors, the state-space equation of the overall dc MG is obtained [10]

$$\dot{X} = \bar{A}X + \bar{D}P + \bar{B}_{es}i_{es} + \bar{B}_sV_{dc} \quad (7)$$

where $X = [x_1^T \ x_2^T \ \dots \ x_Q^T \ x_s^T]^T$, $P = [P_1, \dots, P_Q]^T$, and

$$\bar{A} = \begin{bmatrix} A_1 & 0 & \dots & 0 & A_{1s} \\ 0 & A_2 & \dots & 0 & A_{2s} \\ \vdots & \vdots & \ddots & \vdots & \vdots \\ 0 & 0 & \dots & A_Q & A_{Qs} \\ A_{cn} & A_{cn} & \dots & A_{cn} & A_s \end{bmatrix}, \quad \bar{D} = \begin{bmatrix} d_1 & 0 & \dots & 0 \\ 0 & d_2 & \dots & 0 \\ \vdots & \vdots & \ddots & \vdots \\ 0 & 0 & \dots & d_Q \\ 0 & 0 & \dots & 0 \end{bmatrix}, \quad \bar{B}_{es} = \begin{bmatrix} 0 \\ \vdots \\ 0 \\ b_{es} \end{bmatrix}, \quad \bar{B}_s = \begin{bmatrix} 0 \\ \vdots \\ 0 \\ b_s \end{bmatrix}. \quad (8)$$

In the following, the goal is to propose a systematic approach to estimate the unknown power of the CPLs (i.e., P).

III. NONLINEAR OBSERVER

In this section, the goal is to design a nonlinear observer to estimate the instantaneous value of the CPLs powers. To achieve this, the unknown CPL power vector is treated as a disturbance and a NDOB for this vector is proposed. Generally, the rationale behind a disturbance observer is to calculate the unknown disturbance by comparing the actual value of the system information with that of the nominal system. The difference between

these values is assumed to be caused by the effect of the disturbance on the actual system output. Particularly, for the dc MGs, the variation of the CPLs powers affects the voltage and current of the MG. Therefore, by evaluating the variations in the MG states, one can estimate the variations and the exact value of the CPLs powers.

Consider the dc MG system in (7), which contains the nonlinear term \bar{D} . For such a system, the following power observer structure is proposed:

$$\begin{aligned}\dot{z} &= -L_o (\bar{D}z + \bar{A}X + \bar{B}_{es}i_{es} + \bar{B}_sV_{dc} + \bar{D}s) \\ \hat{P} &= z + s\end{aligned}\quad (9)$$

where z is the internal state vector of the power observer, \hat{P} is the estimated power of the CPLs, L_o is the observer gain matrix, and s is an auxiliary vector. The performance of the observer and the convergence of the estimates to the true values are highly dependent on the selection of L_o and s . The following theorem shows how to choose these parameters to guarantee convergence.

Theorem 1: The unknown power vector in (7) can be estimated by the proposed nonlinear observer (9) with the following parameters:

$$s = L_o X \quad (10)$$

$$L_o = -\alpha(\bar{D}^T \bar{D})^{-1} \bar{D}^T. \quad (11)$$

Furthermore, these parameters guarantee the stability of the estimation error.

Proof: Define the power estimation error as $e = \hat{P} - P$. Taking the time derivative of the estimation error and using the system and observer equations (7) and (9) provides

$$\begin{aligned}\dot{e} &= \dot{\hat{P}} - \dot{P} \\ &= \dot{z} + \dot{s} - \dot{P} \\ &= -L_o (\bar{D}z + \bar{A}X + \bar{B}_{es}i_{es} + \bar{B}_sV_{dc} + \bar{D}s) + \dot{s} - \dot{P}.\end{aligned}\quad (12)$$

Since $s = \hat{P} - z$, one has

$$\begin{aligned}\dot{e} &= -L_o (\bar{D}z + \bar{A}X + \bar{B}_{es}i_{es} + \bar{B}_sV_{dc} \\ &\quad + \bar{D}(\hat{P} - z)) + \dot{s} - \dot{P} \\ &= -L_o (\bar{A}X + \bar{B}_{es}i_{es} + \bar{B}_sV_{dc} + \bar{D}\hat{P}) + \dot{s} - \dot{P}.\end{aligned}\quad (13)$$

On the other hand, from (7) one has

$$\bar{A}X + \bar{B}_{es}i_{es} + \bar{B}_sV_{dc} = \dot{X} - \bar{D}P. \quad (14)$$

Consequently,

$$\begin{aligned}\dot{e} &= -L_o (\dot{X} - \bar{D}P + \bar{D}\hat{P}) + \dot{s} - \dot{P} \\ &= -L_o \bar{D}e - L_o \dot{X} + \dot{s} - \dot{P}.\end{aligned}\quad (15)$$

Considering (10), (15) is continued as

$$\dot{e} = -L_o \bar{D}e - \dot{P}. \quad (16)$$

In the following, the goal is to select the gain matrix, L_o , so that the stability of (16) is assured. Consider the following quadratic Lyapunov candidate:

$$V = \frac{1}{2} e^T e. \quad (17)$$

The time derivate of (17) along the trajectory (16) is

$$\begin{aligned}\dot{V} &= \dot{e}^T e \\ &= -e^T \bar{D}^T L_o^T e - \dot{P}^T e.\end{aligned}\quad (18)$$

Using (11) then yields

$$\begin{aligned}\dot{V} &= -\alpha e^T e - \dot{P}^T e \\ &\leq -\alpha \|e\|^2 + \|\dot{P}\| \|e\| \\ &= -\|e\| \left(\alpha \|e\| - \|\dot{P}\| \right).\end{aligned}\quad (19)$$

For the region $\Omega(e) = \{e(t) \mid \|e\| > \frac{\|\dot{P}\|}{\alpha}\}$, one concludes that $\dot{V} < 0$. Therefore, for a bounded $\|\dot{P}\|$, the trajectory of the error will enter into the bounded region $\bar{\Omega}(e) = \{e(t) \mid \|e\| \leq \frac{\|\dot{P}\|}{\alpha}\}$ as $t \rightarrow \infty$ [24]. Therefore, the error will be bounded. Moreover, (19) can be continued as

$$\begin{aligned}\dot{V} &\leq -\alpha \|e\|^2 + \|\dot{P}\| \|e\| \\ &= -2\alpha V + \Gamma(t)\end{aligned}\quad (20)$$

where $\Gamma(t)$ is bounded, because $\|\dot{P}\|$ and $\|e\|$ are bounded. Solving the dynamic equation (20) provides [25]

$$V(t) \leq e^{-2\alpha t} V(0) + \int_0^t e^{-2\alpha \tau} \Gamma(t-\tau) d\tau. \quad (21)$$

Considering the fact that the estimation error is bounded, (21) is continued as

$$\begin{aligned}V(t) &\leq e^{-2\alpha t} V(0) + \|\Gamma(t)\| \int_0^t e^{-2\alpha \tau} d\tau \\ &= e^{-2\alpha t} V(0) + \frac{1}{2\alpha} \|\Gamma(t)\| (1 - e^{-2\alpha t}) \\ &\leq e^{-2\alpha t} V(0) + \frac{1}{2\alpha} \|\Gamma(t)\|.\end{aligned}\quad (22)$$

Substituting (17) into (22) results in

$$\|e(t)\|^2 \leq e^{-2\alpha t} \|e(0)\|^2 + \frac{1}{\alpha} \|\Gamma(t)\| \quad (23)$$

therefore,

$$\|e(t)\| \leq e^{-\alpha t} \|e(0)\| + \sqrt{\frac{1}{\alpha} \|\Gamma(t)\|}. \quad (24)$$

As can be seen from (24), when $t \rightarrow \infty$, the ultimate bound of the error will be

$$\lim_{t \rightarrow \infty} \|e(t)\| \leq \max_{0 < t < \infty} \sqrt{\frac{1}{\alpha} \|\Gamma(t)\|}. \quad (25)$$

Consequently, the estimation error is bounded. Note that the term $\Gamma(t)$ is dependent on \dot{P} . Thus, for the constant loads and slowly varying load powers, the upper bound of the error is small, and thereby, the proof is completed.

IV. NONLINEAR TS-BASED MPC CONTROLLER

This section deals with the design of a nonlinear MPC scheme based on the TS fuzzy model. The aggregation of the MPC technique with fuzzy methods [26]–[29] brings about a simple but effective control strategy. In this section, the designing of a nonlinear MPC controller based on the TS fuzzy model of the system is provided. Applying the so-called sector nonlinearity approach [25] and Euler discretizing method [30], the dynamic equation (7) can be represented by the following discrete-time TS fuzzy system [2]:

$$\begin{cases} x_{k+1} = \sum_{i=1}^r h_i A_i x_k + \sum_{i=1}^r h_i B_i u_k + \sum_{i=1}^r h_i E_i \\ \quad = A_h x_k + B_h u_k + E_h \\ y_k = \sum_{i=1}^r h_i C_i x_k = C_h x_k. \end{cases} \quad (26)$$

The considered cost function is a standard finite-horizon linear quadratic cost

$$J(N_p, N_u) = \sum_{j=1}^{N_p} [\hat{y}_{k+j|k} - w_{k+j}]^2 + \sum_{j=1}^{N_u} u_{k+j-1}^2 \quad (27)$$

where N_p and N_u are the prediction and control horizons, respectively, $\hat{y}_{k+j|k}$ is the maximum likelihood j -step ahead prediction of the output, and $w(k+j)$ is the future reference. Output and input vectors are defined as

$$\begin{aligned} Y &= [\hat{y}_{k+1|k} \ \hat{y}_{k+2|k} \ \dots \ \hat{y}_{k+N_p|k}]^T \\ U &= [u_k \ u_{k+1} \ \dots \ u_{k+N_u-1}]^T. \end{aligned} \quad (28)$$

To obtain the control input, u_{k+j-1} , it is required to minimize the cost function J given in (27) with respect to U . This can be done by substituting the TS fuzzy model (26) in the cost function. Then, the values of the predicted outputs, $\hat{y}_{k+j|k}$, are calculated as a function of past values of the system characteristics and future control signals. The computed predictions are as

$$\begin{aligned} Y &= \begin{bmatrix} C_h A_h \\ C_h A_h^2 \\ \vdots \\ C_h A_h^{N_p} \end{bmatrix} x_k + \begin{bmatrix} C_h E_h \\ C_h (I + A_h) E_h \\ \vdots \\ \sum_{i=0}^{N_p-1} C_h A_h^i E_h \end{bmatrix} \\ &+ \begin{bmatrix} C_h B_h & \dots & 0 \\ C_h A_h B_h & \dots & 0 \\ \vdots & \ddots & \vdots \\ C_h A_h^{N_p-1} B_h & \dots & C_h A_h^{N_p-N_u} B_h \end{bmatrix} U. \end{aligned} \quad (29)$$

Then, (29) can be rewritten in the vector form

$$Y = \Psi + \Theta U \quad (30)$$

where

$$\begin{aligned} \Psi &= \begin{bmatrix} C_h A_h \\ C_h A_h^2 \\ \vdots \\ C_h A_h^{N_p} \end{bmatrix} x_k + \begin{bmatrix} C_h E_h \\ C_h (I + A_h) E_h \\ \vdots \\ \sum_{i=0}^{N_p-1} C_h A_h^i E_h \end{bmatrix} \\ \Theta &= \begin{bmatrix} C_h B_h & \dots & 0 \\ C_h A_h B_h & \dots & 0 \\ \vdots & \ddots & \vdots \\ C_h A_h^{N_p-1} B_h & \dots & C_h A_h^{N_p-N_u} B_h \end{bmatrix}. \end{aligned}$$

The cost function (27) can similarly be presented in the vector form as follows:

$$J(N_p, N_u) = (Y - W)^T (Y - W) + U^T U \quad (31)$$

where

$$W = [w(k+1) \ w(k+2) \ \dots \ w(k+N_p)]^T. \quad (32)$$

Substituting (30) into (31) yields the quadratic form

$$J(N_p, N_u) = U^T H U + K U + U^T K^T + G \quad (33)$$

where

$$H = \Theta^T \Theta \geq 0; \quad K = (\Psi - W)^T \Theta;$$

$$G = (\Psi - W)^T (\Psi - W).$$

Minimizing J with respect to U is a quadratic problem. Setting the derivative of (33) with respect to the vector U equal to zero, the analytical solution can be obtained as

$$U = (\Theta^T \Theta)^{-1} \Theta^T (\Psi - W). \quad (34)$$

Remark 1. (Online implementation of the proposed approach): the proposed adaptive controller comprises two parts: a *nonlinear observer* to estimate the instantaneous value of the power of the uncertain CPLs and an *adaptive MPC* to optimally design the value of the injecting current of the energy storage unit. Although the mathematical derivations of these two parts are derived independently, they must be performed simultaneously to implement the overall controller. In the following, the detailed algorithm of the proposed controller is summarized.

- 1) Choose an initial guess for the CPLs powers $\hat{P}(0)$.
- 2) Use $\hat{P} = z + s$ in (9) and (10) to compute $z(0)$.
- 3) Measure the currents and voltages (i.e., X) of the dc MG.
- 4) Update the CPL power estimation by (9).
- 5) Construct Θ , Δ , and Ψ based on the estimations.
- 6) Compute the injecting current based on (34).
- 7) Apply the value of the injecting current to the dc MG.
- 8) Go to line 3.

Steps 1 and 2 are performed offline in order to obtain initial values for the observer, while Steps 3–8 describe the online execution of updating the observer and computation of the control signal.

Remark 2. (Advantages of the proposed approach): the advantages of the proposed nonlinear controller to control the dc MGs containing uncertain time-varying CPLs over the existing controllers is as follows:

TABLE I
PARAMETERS FOR DC MG WITH ONE CPL

$r_1 = 1.1 \Omega$	$v_{C0,1} = 196.64$	$C_s = 500 \mu F$
$L_1 = 39.5 mH$	$\tilde{x}_{2N} = 130.4$	$V_{dc} = 200 V$
$C_1 = 500 \mu F$	$r_s = 1.1 \Omega$	
$P_1 = 300 W$	$L_s = 39.5 mH$	

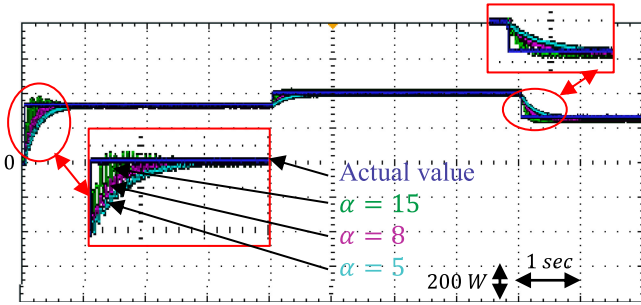

Fig. 5. Actual and estimation of the power of the CPL.

- 1) Compared to the previously mentioned backstepping [8] and sliding mode control designs [31], the proposed approach does not need any time derivatives of states, which makes it more robust against noises. Also, compared to the feedback linearization method [7], the proposed approach is more robust against the system uncertainties, because no nonlinearity cancelation is needed. Moreover, compared to the linear controllers [10], the proposed approach brings about a global stabilization.
- 2) Although some papers try to handle the non-ideal CPLs as uncertainties with a pre-given upper bound and employ a robust scheme [11]–[13], these approaches have some drawbacks, as follows: a) the design procedure of these approaches is dependent on priori bounds for the powers of the CPLs. Therefore, if the upper bound changes, one needs to redesign the controller; b) if the CPL power exceeds the upper limits, the existing robust controllers are unable to stabilize the system, which means that to comply with safety issues, one may need to choose very conservative upper limits. On the other hand, since a robust controller is designed for the worst case, choosing higher values for the bounds increases the energy consumption and results in a higher injection current. However, the proposed adaptive controller avoids the mentioned drawbacks by estimating the instantaneous values of the powers instead of considering priori upper bounds. Since the injection current at each instant is designed based on the estimated instantaneous power, a lower power will, in general, be injected to the dc MG.

V. EXPERIMENTAL RESULTS

The MG parameters used in the experiments are listed in Table I. The control algorithm is implemented in a DSpace MicroLabBox with DS1202 Power PC Dual-Core 2 GHz processor

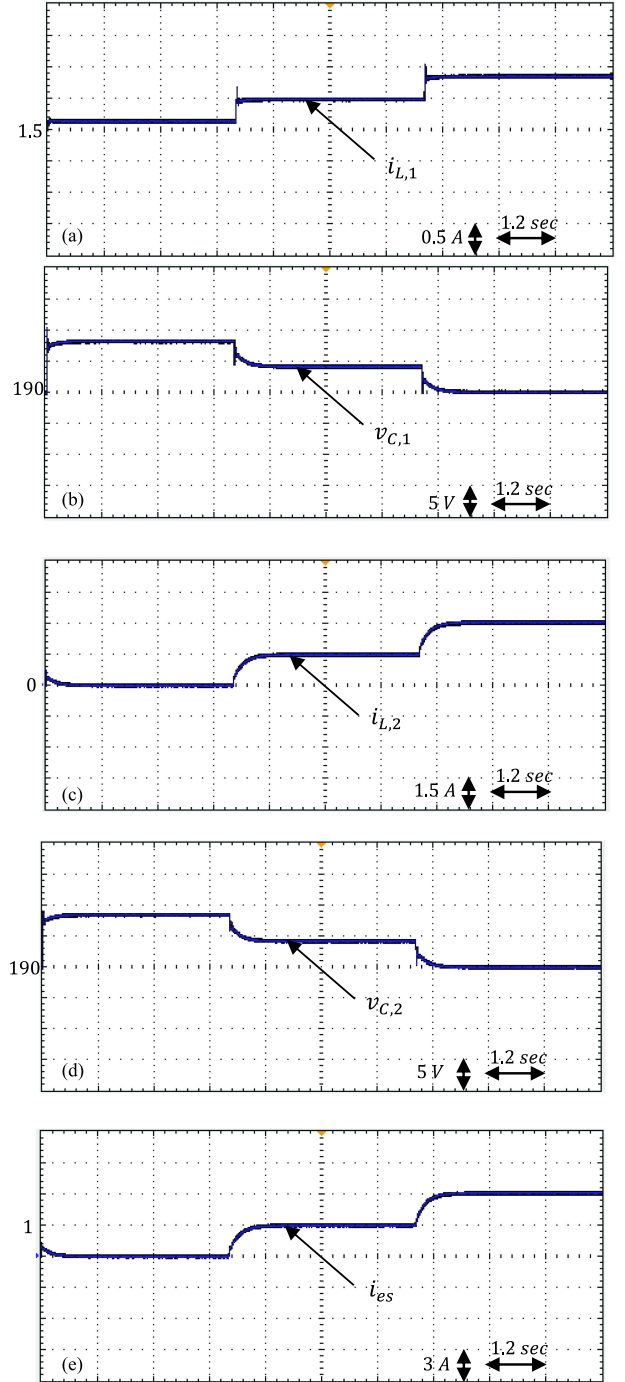

Fig. 6. DC MG states and control input.

board and DS1302 I/O board with the sampling time $100 \mu s$. To investigate the robustness and fast transient performance of the proposed approach, it is tested on an MG with parameters given in Table I and the results are compared with [7], [8], and [10].

Scenario 1: consider an MG with only one CPL whose power is within the stability range. Thereby, the value of the injection current is set as zero. For such a system, the effectiveness of the proposed nonlinear power observer is investigated. Also,

the effect of the parameter α in the observer gain matrix (11) is studied. The actual value of the CPL power and its estimation obtained by the observer (9) with parameters (10) and (11) are depicted in Fig. 5. Three observer gain matrices are considered by selecting the three values $\alpha = 5, 8, 15$ and the CPL power is estimated based on each gain.

As can be seen in Fig. 5, the proposed nonlinear dynamic observer can effectively estimate the unknown power of the CPL. By selecting a higher value of α , the convergence speed is increased by the expense of increasing overshoot in estimations. For instance, at the starting time of the simulations, since the initial condition for the observer is far away from the actual value of the CPL power, an overshoot can be observed in the estimation when $\alpha = 15$. Meanwhile, the settling time (using a 5% criterion) is about 0.35 s. Conversely, if α is chosen too small, the convergence time may be large. For $\alpha = 8$ and 5, the settling time is about 0.57 and 0.73 s, respectively. Thus, one needs to consider a trade-off between the overshoot and convergence time.

Scenario 2: in this scenario, the proposed adaptive TS fuzzy-based MPC is utilized to stabilize an MG with non-ideal CPL with unknown and varying power. The designs presented in [7], [8], and [10] cannot stabilize the system when the value of the power is not known a priori. In addition, the mentioned approaches cannot modify the value of the injecting current even if the actual value of the time-varying power of the CPL is available. Based on the transient performance analysis in Scenario 1, the value of α in (11) is set as $\alpha = 8$ and the power of the CPLs is estimated. Then, the adaptive fuzzy MPC deploys the information of the MG and the estimated power of the CPL to optimally design the value of the injecting current to stabilize the system. The voltages and currents of the CPL's and source's filters are illustrated in Fig. 6. Fig. 6 illustrates the efficiency of the presented approach in stabilizing the overall system and compensating for the changes in load power demand.

VI. CONCLUSION

In this paper, a novel TS fuzzy-based adaptive controller is proposed to modify the ESS current according to the changes in a CPL power included in a dc MG. The unknown time-varying CPL powers are estimated by a modified NDOB. Experimental results show that the proposed nonlinear observer can effectively estimate the value of the CPL power with a low overshoot and a high convergence speed. In addition, the proposed adaptive controller is robust against CPL power variations; it can stabilize the overall dc MG very fast and avoid oscillations in the system states. In future work, one might consider modifying the proposed power observer to simultaneously estimate the CPLs powers demand and the other system parameters. Also, improving the convergence speed of the estimations is suggested to enhance the transient performance of the closed-loop dc MG. Furthermore, extending the results of this paper to other topologies of dc MGs with battery charging and discharging and incorporating with a droop control are considered to be of great importance.

REFERENCES

- [1] S. Yousefzadeh, J. D. Bendtsen, N. Vafamand, M. H. Khooban, T. Dragicevic, and F. Blaabjerg, "Tracking control for a DC microgrid feeding uncertain loads in more electric aircraft: Adaptive backstepping approach," *IEEE Trans. Ind. Electron.*, 2018, doi: [10.1109/TIE.2018.2880666](https://doi.org/10.1109/TIE.2018.2880666).
- [2] S. Yousefzadeh, J. D. Bendtsen, N. Vafamand, M. H. Khooban, T. Dragičević, and F. Blaabjerg, "EKF-based predictive stabilization of shipboard DC microgrids with uncertain time-varying loads," *J. Emerg. Sel. Topics Power Electron.*, 2018.
- [3] N. Vafamand, M. H. Khooban, T. Dragicevic, and F. Blaabjerg, "Networked fuzzy predictive control of power buffers for dynamic stabilization of DC microgrids," *IEEE Trans. Ind. Electron.*, vol. 66, no. 2, pp. 1356–1362, Feb. 2019.
- [4] Z. Jin, G. Sulligoi, R. Cuzner, L. Meng, J. C. Vasquez, and J. M. Guerrero, "Next-generation shipboard DC power system: Introduction smart grid and dc microgrid technologies into maritime electrical networks," *IEEE Electr. Mag.*, vol. 4, no. 2, pp. 45–57, Jun. 2016.
- [5] S. Singh, A. R. Gautam, and D. Fulwani, "Constant power loads and their effects in DC distributed power systems: A review," *Renewable Sustain. Energy Rev.*, vol. 72, pp. 407–421, 2017.
- [6] P. Magne, B. Nahid-Mobarakeh, and S. Pierfederici, "General active global stabilization of multiloading DC-power networks," *IEEE Trans. Power Electron.*, vol. 27, no. 4, pp. 1788–1798, Apr. 2012.
- [7] G. Sulligoi, D. Bosich, G. Giadrossi, L. Zhu, M. Cupelli, and A. Monti, "Multiconverter medium voltage DC power systems on ships: Constant-power loads instability solution using linearization via state feedback control," *IEEE Trans. Smart Grid*, vol. 5, no. 5, pp. 2543–2552, Sep. 2014.
- [8] Q. Xu, C. Zhang, C. Wen, and P. Wang, "A novel composite nonlinear controller for stabilization of constant power load in DC microgrid," *IEEE Trans. Smart Grid*, 2017, doi: [10.1109/TSG.2017.2751755](https://doi.org/10.1109/TSG.2017.2751755).
- [9] D. Marx, P. Magne, B. Nahid-Mobarakeh, S. Pierfederici, and B. Davat, "Large signal stability analysis tools in DC power systems with constant power loads and variable power loads—A review," *IEEE Trans. Power Electron.*, vol. 27, no. 4, pp. 1773–1787, Apr. 2012.
- [10] L. Herrera, W. Zhang, and J. Wang, "Stability analysis and controller design of DC microgrids with constant power loads," *IEEE Trans. Smart Grid*, vol. 8, no. 2, pp. 881–888, Mar. 2017.
- [11] S. Sumsurooah, M. Odavic, and S. Bozhko, " μ approach to robust stability domains in the space of parametric uncertainties for a power system with ideal CPL," *IEEE Trans. Power Electron.*, vol. 33, no. 1, pp. 833–844, Jan. 2018.
- [12] J. Liu, W. Zhang, and G. Rizzoni, "Robust stability analysis of DC microgrids with constant power loads," *IEEE Trans. Power Syst.*, vol. 33, no. 1, pp. 851–860, Jan. 2018.
- [13] E. Hossain, "Addressing instability issues in microgrids caused by constant power loads using energy storage systems," Ph.D. Thesis, Univ. Wisconsin-Milwaukee, Milwaukee, WI, USA, 2016.
- [14] G. Liao, Y. Sheng, and X. Zeng, "Spacecraft hovering around asteroid via disturbance observer based exponential time-varying sliding mode controller," in *Proc. 13th IEEE Int. Conf. Control Autom.*, 2017, pp. 313–318.
- [15] M. Huba, P. Bisták, and P. Āpák, "Combining model based and data-driven approaches: First order nonlinear plants control," in *Proc. 19th Int. Conf. Elect. Drives Power Electron.*, 2017, pp. 330–335.
- [16] A. Mohammadi, H. J. Marquez, and M. Tavakoli, "Nonlinear disturbance observers: Design and applications to Euler-Lagrange systems," *IEEE Control Syst.*, vol. 37, no. 4, pp. 50–72, Aug. 2017.
- [17] N. Vafamand, S. V. Naghavi, A. A. Safavi, A. Khayatian, M. H. Khooban, and T. Dragičević, "TS-based sampled-data model predictive controller for continuous-time nonlinear systems," *Int. J. Syst. Sci.*, 2018, doi: [10.1080/00207721.2018.1536234](https://doi.org/10.1080/00207721.2018.1536234).
- [18] N. Vafamand and A. Khayatian, "Model predictive-based reset gain-scheduling dynamic control law for polytopic LPV systems," *ISA Trans.*, vol. 81, pp. 132–140, Aug. 2018.
- [19] S. Bououden, M. Chadli, S. Filali, and A. El Hajjaji, "Fuzzy model based multivariable predictive control of a variable speed wind turbine: LMI approach," *Renewable Energy*, vol. 37, no. 1, pp. 434–439, Jan. 2012.
- [20] M. H. Khooban, N. Vafamand, and T. Niknam, "T-S fuzzy model predictive speed control of electrical vehicles," *ISA Trans.*, vol. 64, pp. 231–240, May 2016.
- [21] M. H. Khooban, N. Vafamand, T. Niknam, T. Dragicevic, and F. Blaabjerg, "Model-predictive control based on Takagi-Sugeno fuzzy model for electrical vehicles delayed model," *IET Elect. Power Appl.*, vol. 11, no. 5, pp. 918–934, 2017.

- [22] M. A. Kardan *et al.*, "Improved stabilization of nonlinear DC microgrids: Cubature Kalman filter approach," *IEEE Trans. Ind. Appl.*, vol. 54, no. 5, pp. 5104–5112, Sep. 2018.
- [23] M. M. Mardani, N. Vafamand, M. H. Khooban, T. Dragicevic, and F. Blaabjerg, "Design of quadratic D-stable fuzzy controller for DC microgrids with multiple CPLs," *IEEE Trans. Ind. Electron.*, 2018, doi: [10.1109/TIE.2018.2851971](https://doi.org/10.1109/TIE.2018.2851971).
- [24] N. Vafamand and M. Rakhshan, "Dynamic model-based fuzzy controller for maximum power point tracking of photovoltaic systems: An linear matrix inequality approach," *J. Dyn. Syst. Meas. Control*, vol. 139, Nov. 2016, Art. no. 051010.
- [25] N. Vafamand, M. H. Asemani, and A. Khayatian, "Robust L1 observer-based non-PDC controller design for persistent bounded disturbed TS fuzzy systems," *IEEE Trans. Fuzzy Syst.*, vol. 26, no. 3, pp. 1401–1413, Jun. 2018.
- [26] M. H. Khooban, D. N. M. Abadi, A. Alfi, and M. Siah, "Optimal type-2 fuzzy controller for HVAC systems," *Automatika*, vol. 55, no. 1, pp. 69–78, Jan. 2014.
- [27] M. H. Khooban, M. R. Soltanpour, D. N. M. Abadi, and Z. Esfahani, "Optimal intelligent control for HVAC systems," *J. Power Technol.*, vol. 93, no. 3, pp. 192–200, 2012.
- [28] M. H. Khooban, T. Niknam, M. Dehghani, and F. Blaabjerg, "Free chattering hybrid sliding mode control for a class of non-linear systems: Electric vehicles as a case study," *IET Sci. Meas. Technol.*, vol. 10, no. 7, pp. 776–785, Oct. 2016.
- [29] N. Vafamand and M. Shasadeghi, "More relaxed non-quadratic stabilization conditions using TS open loop system and control law properties: More relaxed non-quadratic stabilization conditions," *Asian J. Control*, vol. 19, no. 2, pp. 467–481, Mar. 2017.
- [30] B. Stellato, T. Geyer, and P. J. Goulart, "High-speed finite control set model predictive control for power electronics," *IEEE Trans. Power Electron.*, vol. 32, no. 5, pp. 4007–4020, May 2017.
- [31] E. Hossain, R. Perez, S. Padmanaban, and P. Siano, "Investigation on the development of a sliding mode controller for constant power loads in microgrids," *Energies*, vol. 10, no. 8, pp. 1086–1109, Jul. 2017.



Navid Vafamand was born in Iran in 1990. He received the B.Sc. degree in electrical engineering and the M.Sc. degree in control engineering from the Shiraz University of Technology, Shiraz, Iran, in 2012 and 2014, respectively, and is currently working toward the Ph.D. degree in control engineering at Shiraz University, Iran. He is currently a Ph.D. Visiting Student with Aalborg University, Aalborg, Denmark.

He has authored or coauthored more than 50 publications in journals and conferences, plus one book chapter. His main research interests include Takagi–

Sugeno fuzzy models, linear parameter varying systems, predictive control, and stability and control of power systems.

Shirin Yousefzadeh was born in Iran in 1990. She received the B.Sc. degree from the Iran University of Science and Technology, Tehran, Iran, in 2012, and the M.Sc. degree from the Shiraz University of Technology, Shiraz, Iran, in 2015, both in control engineering. Since 2016, she has been working toward the Ph.D. degree in the Department of Electronic Systems, Aalborg University, Aalborg, Denmark.

Her main research interests include nonlinear control theory and applications, fault-tolerant control systems, collaborative robotics, and stability and control of power systems.



Mohammad Hassan Khooban (M'13–SM'18) was born in Shiraz, Iran, in 1988. He received the Ph.D. degree from the Shiraz University of Technology, Shiraz, Iran, in 2017.

He was a Research Assistant with the University of Aalborg, Aalborg, Denmark, from 2016 to 2017 conducting research on microgrids and marine power systems. He is currently a Postdoctoral Associate with Aalborg University. He is author or co-author of more than 100 publications in journals and international conferences, plus one book chapter, and one patent. His research interests include control theory and application, power electronics and its applications in power systems, industrial electronics, and renewable energy systems.

Dr. Khooban is currently an Associate Editor for the *Complexity* journal.



Jan Dimon Bendtsen (M'11) was born in Denmark in 1972. He received the M.Sc. degree in adaptive control using artificial neural networks and the Ph.D. degree in neural modeling and control of thermodynamic processes in thermal power plants from the Department of Control Engineering, Aalborg University, Aalborg, Denmark, in 1996 and 1999, respectively.

Since 2003, he has been an Associate Professor with the Department of Electronic Systems, Aalborg University. In 2005, he was a Visiting Researcher with Australian National University, Canberra, ACT, Australia. Since 2006, he has been involved in the management of several national and international research projects, and organizing international conferences. From 2012 to 2013, he was a Visiting Researcher with the University of California at San Diego, USA. His current research interests include adaptive control of nonlinear systems, closed-loop system identification, control of distribution systems, and infinite-dimensional systems.

Dr. Bendtsen was a corecipient of the Best Technical Paper Award at the American Institute of Aeronautics and Astronautics Guidance, Navigation, and Control Conference in 2009.



Tomislav Dragičević (S'09–M'13–SM'17) received the M.Sc. and the industrial Ph.D. degrees in electrical engineering from the Faculty of Electrical Engineering, Zagreb, Croatia, in 2009 and 2013, respectively.

From 2013 until 2016, he was a Postdoctoral Research Associate with Aalborg University, Aalborg, Denmark. From March 2016, he is an Associate Professor with Aalborg University. He made a Guest Professor stay at Nottingham University, U.K., during spring/summer of 2018. His principal field of

interest is overall system design of autonomous and grid-connected dc and ac microgrids, and application of advanced modeling and control concepts to power electronic systems. He has authored and coauthored more than 140 technical papers (more than 55 of them are published in international journals, mostly IEEE transactions) in his domain of interest and 8 book chapters and a book in the field.

Dr. Dragičević serves as an Associate Editor for the IEEE TRANSACTIONS ON INDUSTRIAL ELECTRONICS and the *Journal of Power Electronics*. He is a recipient of a Končar Prize for the best industrial Ph.D. thesis in Croatia, and a Robert Mayer Energy Conservation Award.