



AALBORG UNIVERSITY
DENMARK

Aalborg Universitet

Analytical Design and Performance Validation of Finite Set MPC Regulated Power Converters

Novak, Mateja; Nyman, Ulrik Mathias; Dragicevic, Tomislav; Blaabjerg, Frede

Published in:
I E E Transactions on Industrial Electronics

DOI (link to publication from Publisher):
[10.1109/TIE.2018.2838073](https://doi.org/10.1109/TIE.2018.2838073)

Publication date:
2019

Document Version
Accepted author manuscript, peer reviewed version

[Link to publication from Aalborg University](#)

Citation for published version (APA):
Novak, M., Nyman, U. M., Dragicevic, T., & Blaabjerg, F. (2019). Analytical Design and Performance Validation of Finite Set MPC Regulated Power Converters. *I E E Transactions on Industrial Electronics*, 66(3), 2004 - 2014. Article 8368064. <https://doi.org/10.1109/TIE.2018.2838073>

General rights

Copyright and moral rights for the publications made accessible in the public portal are retained by the authors and/or other copyright owners and it is a condition of accessing publications that users recognise and abide by the legal requirements associated with these rights.

- Users may download and print one copy of any publication from the public portal for the purpose of private study or research.
- You may not further distribute the material or use it for any profit-making activity or commercial gain
- You may freely distribute the URL identifying the publication in the public portal -

Take down policy

If you believe that this document breaches copyright please contact us at vbn@aub.aau.dk providing details, and we will remove access to the work immediately and investigate your claim.

Analytical Design and Performance Validation of Finite Set MPC Regulated Power Converters

Mateja Novak, *Student Member, IEEE*, Ulrik Mathias Nyman, Tomislav Dragicevic, *Senior Member, IEEE*, and Frede Blaabjerg, *Fellow, IEEE*

Abstract—A new approach to performance validation of finite control set model predictive control (FCS-MPC) regulated power electronics converters is presented in the paper - statistical model checking (SMC). SMC is an established method used in various sectors of industry to provide solutions to problems that are beyond the abilities of classical formal techniques. The method is simple for implementation and requires only an operational system model that can be simulated and checked against properties. The approach will be presented on a standard 2-level voltage source converter (VSC) regulated by the FCS-MPC algorithm. In UPPAAL SMC toolbox the converter system and controller are modeled as a Network of Stochastic Timed Automata. To assess the quality of the model, an equivalent Simulink model is used as a benchmark model. Using the model created in UPPAAL SMC toolbox the performance of the FCS-MPC algorithm is verified. The control algorithm is also tested on an experimental setup. During the evaluation, no significant degradation of reference tracking was found during transients nor under model parameter uncertainty.

Index Terms—Controller performance, DC-AC power conversion, finite control set model predictive control, statistical model checking.

I. INTRODUCTION

CONTROL concept simplicity and the high-performance operation are important factors that decide the success of every new control method for power electronics converters. The cascaded linear control method has a long history of implementation and it is up to date the most matured control concept with widest range of implementation [1]. In this control method, power electronics converter is approximated as a linear system using the modulation techniques (e.g. PWM). However, the application of a linear control method on a non-linear system can lead to variation of performance. Using a non-linear control method the non-linear discrete nature of the power electronic converter can be captured. The non-linear control methods are still under development and with constant improvements new application opportunities are emerging.

Model predictive control (MPC) is one of the non-linear control methods that has received a lot of attention in the recent publications. The algorithm has been adapted to multiple applications in power electronics where linear hierarchical

control was dominating in the past years like electrical drives [2], [3], power filters [4], STATCOM [5], photovoltaics [6], microgrids [7] and many more. The system constraints and multi objective algorithms can easily be implemented making this control concept very attractive due to its straightforward design. In contrast to the cascaded linear control, where for every controlled variable an independent control loop has to be designed, the structure of the MPC algorithm can include all controlled variables in a single control loop. The core element of the control is the discrete model of the voltage source converter (VSC) and the converter output filter. Using the discrete model, the propagation of the control variables for the next sampling interval is calculated. The calculations are conducted for all possible converter switching states. The switching state which will produce the smallest difference between the control variable and the reference value will be applied to the converter switching devices. The latter is implemented in a form of a cost function, which typically has a structure of square of Euclidean distance between the reference signal and the prediction of the controlled variable. Most common objectives that can be included in a cost function are minimization of the reference tracking error [7], switching loss minimization [8], harmonics elimination [9], [10] and common-mode voltage minimization [11], [12]. The priorities of control objectives in the cost function are defined by weighting factors. An overview of the converter objectives regarding their application is well presented in [13]. The quality of the prediction model has high importance as it directly affects the controller performance. If the parameters of the system are changing estimators are needed to ensure the predictions are correctly calculated.

Predictive control algorithms can be divided into two categories depending on how the optimization is performed and applied. The continuous control set MPC (CCS-MPC) produces a continuous reference that has to be modulated before it is applied to converter switching devices [14]–[16]. On the other hand, finite control set MPC (FCS-MPC), which is a type of direct MPC, can directly apply the algorithm's output signal to converter switching devices using an iterative algorithm to find the optimum switching state [17], [18].

MPC methods are not exactly a novelty in power electronics applications [19], however there are some aspects which are important for their implementation that have not yet been fully studied [13], [19]–[21]. An efficient cost function design and weighting factor tuning process are one of the current concerns of MPC application in power electronics. While the traditional linear control algorithm can rely on well established

Manuscript received November 15, 2017; revised February 27 and April 17, 2018; accepted May 3, 2018.

M. Novak, T. Dragicevic and F. Blaabjerg are with the Department of Energy Technology, Aalborg University, Aalborg, Denmark e-mail: (nov@et.aau.dk, tdr@et.aau.dk, fbl@et.aau.dk).

U.M. Nyman is with with Department of Computer Science, Aalborg University, Aalborg, Denmark email:(ulrik@cs.aau.dk).

methods and guidelines to tune the controller parameters and verify the performance, MPC is still in need of analytical tools to improve the design process, evaluate the performance and demonstrate the stability. The issue of performance verification of the FCS-MPC algorithm under different operating conditions, e.g. steady-state, transient load changes and parameter model mismatches, will be addressed in this paper. For steady-state performance, the algorithm verification method must prove that the converter output voltages and currents will stay within the THD limits prescribed by the standards. On the other hand, transient load change can be treated as a disturbance in the system; therefore, verification must ensure that the converter control can have a quick response and adjust to the new conditions in the system without causing larger variations than prescribed by the standards as well. Finally, the verification under parameter mismatch should be done because the controller relies on the model.

This paper is organized as follows. Section II outlines the most relevant research in the field of FCS-MPC stability and performance verification. The system model is introduced in Section III along with FCS-MPC algorithm and the defined cost function. Section IV gives a brief introduction of the Statistical Model Checking (SMC), a method used in this paper to verify the performance of the system. The presented FCS-MPC algorithm is verified in simulations and on experimental set-up in Sections V and VI, respectively. Results obtained by UPPAAL SMC toolbox are presented and discussed in Section VII. Finally, in Section VIII conclusions are provided.

II. FCS-MPC STABILITY, PERFORMANCE AND ROBUSTNESS RESEARCH

Every control algorithm application demands a verification of the performance and stability in closed-loop operation. In closed-loop control of the power converters, output variables like voltages, currents and power tend to diverge from the set-point values, so for a system to be addressed as stable it has to have the ability to prevent small input perturbations or disturbance in the control loop to cause large variations in the behavior of the converter output variables. Closed-loop stability of the MPC is usually analyzed using Lyapunov stability theory and the infinite-horizon MPC guarantees stability, however the closed-loop MPC is not necessarily stable with short prediction horizons [22]. FCS-MPC methods can't rely on the well established traditional methods used for linear systems due to their non-linear nature, a closed-loop stability analysis of FCS-MPC is difficult unless complicated mathematics is employed [21]. Because of the lack of analytical tools to evaluate the performance of MPC for power converters, extensive simulations or experiments were used to check the algorithm performance [19]. It is evident that a new approach is needed in this area. Table I presents an overview of research done in the field of FCS-MPC performance and stability verification. The most commonly used approach to test the performance and robustness of the FCS-MPC is by running multiple simulations with different system parameters to see how the converter outputs will respond to model uncertainties [23], [24]. The performance under model uncertainties can as

well be checked experimentally [25] and then be compared to a benchmark model with a classical PI linear control [26]. While conducting the experimental validation it was noticed that the performance of the control deteriorates for underestimated inductance, however almost no effect on performance was noticed for an overestimated value [25]. Both methods showed excellent steady- and transient-state response [26], however their deficiency is not providing the information needed to guarantee the stability of the control algorithm. While simulations can be performed in parallel to speed up the process of obtaining the results, experiments are more time consuming.

The authors of [27]–[29] presented the most relevant progress in validating the stability of FCS-MPC. They verified the practical stability of FCS-MPC i.e. asymptotically stability under specific constraints by designing the cost function as a Lyapunov function for the VSC, DC-DC buck and multicell converter (MCC), but the design of the cost function is now more complex compared to the one used in simulations and experiments. The main drawback of the method is that it can be applied only to one class of converters. Therefore, more research is still needed to make this approach applicable for other applications [20]. A similar approach was presented for an active front end (AFE) VSC, however the algorithm used differs from the conventional FCS-MPC [30]. The objective of this paper is to present an alternative method for FCS-MPC performance verification in power electronics, which is intuitive for industrial engineers to implement and use so new control algorithms can quickly be assessed before implementations. Using the presented new approach and Lyapunov stability criteria as explained in [27]–[29] both stability and performance of the FCS-MPC algorithm can be verified for different applications.

III. SYSTEM MODEL

The design process of an MPC algorithm can be summed into three stages: identifying all possible switching states and their relations to input/output voltages and currents, defining a cost function that will represent the desired behavior of the system and then obtain the discrete-time model used for prediction of the future behavior of controlled variables [31]. To obtain the discrete-time model of the system, Euler forward method is usually applied for low order systems. Depending on converter application a variety of cost functions can be found in the literature. The 2L-VSC converter with LC output filter in this paper is used to obtain a sinusoidal output voltage with low harmonic distortion e.g. for uninterruptible power supply (UPS) systems Fig. 1. UPS systems are usually used to provide emergency power during grid blackouts. Their design and performance requirements are defined in the IEC Standard 62040-3 [32]. As presented in Fig. 1 the main controller variables are the output filter currents $i_{f abc}$, output capacitor voltages $v_{c abc}$ and output load currents $i_{o abc}$. The system model can be described by the following state-space equations:

$$\frac{d}{dt} \begin{bmatrix} i_{f abc} \\ v_{c abc} \end{bmatrix} = \begin{bmatrix} 0 & -\frac{1}{L_f} \\ \frac{1}{C_f} & 0 \end{bmatrix} \begin{bmatrix} i_{f abc} \\ v_{c abc} \end{bmatrix} + \begin{bmatrix} \frac{1}{L_f} & 0 \\ 0 & -\frac{1}{C_f} \end{bmatrix} \begin{bmatrix} v_i abc \\ i_o abc \end{bmatrix} \quad (1)$$

TABLE I
LITERATURE OVERVIEW OF STATE-OF-THE-ART STABILITY, ROBUSTNESS AND PERFORMANCE VALIDATION OF FCS-MPC

Target object	Method	Advantages	Disadvantages	Verified performance	Verified stability
MMC [24] 4-leg VSC [23]	Multiple sim., parameter sweep	Quick, simple cost function design	Closed loop stability not defined, not a verified method	Yes	No
2L-VSC [26]	Multiple exp., benchmarking	Quick, simple cost function design	Closed loop stability not defined, not a verified method, time consuming	Yes	No
2L-VSC [27] DC-DC [28] MCC [29]	Lyapunov stability theory	Verified method	Only stability of a neighborhood of the system reference is guaranteed, complex cost function design	Yes	Yes
AFE [30]	Lyapunov stability theory	Verified method	Not a conventional FCS, complex cost function design	No	Yes

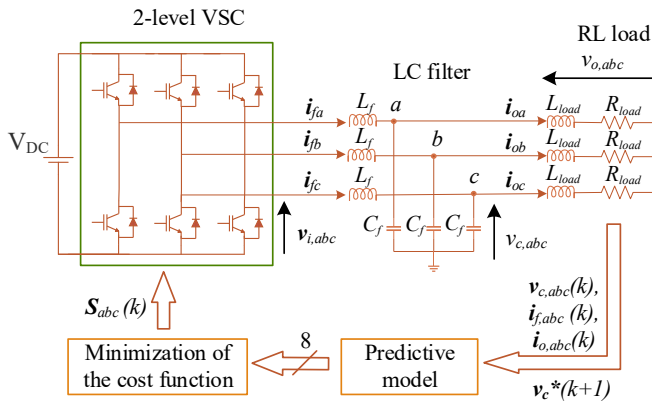

Fig. 1. Simplified scheme of model predictive control for 2-level VSC.

where L_f and C_f represent the output filter inductance and capacitance, $v_{i,abc}$ is the inverter output voltage. Tracking the capacitor voltage reference $v_c^*_{abc}$ by computing the converter output voltage $v_{i,abc}$ is the main objective of the algorithm. The secondary objectives include a derivative current component and minimization of the switching frequency to limit the number of commutations. The derivative component in the cost function improves the converter's voltage tracking performance and lowers the THD [7]. Therefore, the cost function of the described system (1) is defined as:

$$g = (v_{c\alpha}^* - v_{c\alpha}^P)^2 + (v_{c\beta}^* - v_{c\beta}^P)^2 + \lambda_d \cdot g_d + \lambda_{sw} \cdot n^2 \quad (2)$$

$$g_d = (i_{f\alpha}^P - i_{o\alpha} + C_f \omega v_{c\beta}^*)^2 + (i_{f\beta}^P - i_{o\beta} - C_f \omega v_{c\alpha}^*)^2 \quad (3)$$

where $v_{c\alpha}^*$ and $v_{c\beta}^*$ represent the real and imaginary parts of the reference voltage vector $v_c^*(k) = v_{c\alpha}^* + jv_{c\beta}^*$, $v_{c\alpha}^P$ and $v_{c\beta}^P$ the real and imaginary parts of the predicted voltage vector $v_c^P(k+1) = v_{c\alpha}^P + jv_{c\beta}^P$, $i_{f\alpha}^P$ and $i_{f\beta}^P$ the real and imaginary parts of the predicted filter current vector $i_f^P(k+1) = i_{f\alpha}^P + ji_{f\beta}^P$, $i_{o\alpha}$ and $i_{o\beta}$ the real and imaginary parts of the measured load current. λ_d and λ_{sw} are the weighting factors of the secondary objectives and n is the number of switches that change when the switching state $S_x(k)$, $x \in (a, b, c)$ is applied and it is calculated using the following expression:

$$n = \sum_{x=a,b,c} |S_x(k) - S_x(k-1)| \quad (4)$$

where $S_x(k)$ is the new potential switching state and $S_x(k-1)$ is the applied switching state from the previous switching instant. The THD factor of $v_{c,abc}$ and average switching frequency $f_{sw,avg}$ were defined as performance values to determine the weighting factors. During the simulation time interval, $f_{sw,avg}$ is calculated as a sum of the switching frequencies in each phase divided by the number of switches:

$$f_{sw,avg} = \sum_{i=1}^n \frac{f_{sw_{ai}} + f_{sw_{bi}} + f_{sw_{ci}}}{6} \quad (5)$$

where $i \in 1, 2$, n represents the number of switches in each phase leg. The permitted THD factor for converters used for UPS is defined by the IEC Standard 62040-3 [32], therefore the selected λ_{sw} in the cost function should not produce a larger THD than defined in the standard. The predicted voltage vector in the discretized model of the system $v_c^P(k+1)$ is calculated using the measurements of the filter current i_f , capacitor voltage v_c and load current i_o . The discrete-time model of the system (1) was obtained through forward Euler method as presented in [7].

IV. STATISTICAL MODEL CHECKING

Statistical model checking is a well known technique used in aeronautics and embedded automotive systems, sensor networks, and communication systems to provide solutions to problems that are beyond the abilities of classical formal techniques [33]–[35]. As explained in the state of the art we can distinguish three approaches for stability and performance verification: multiple simulations, experiments and analytical analysis using the Lyapunov stability criteria. Our focus will be on performance verification methods. From the aspect of simplicity running multiple simulations seems as the most simple approach but also time consuming. Further on it is missing the reliability of the procedure. Since there is no guarantee for a finite set of experiments to cover all possible scenarios, errors could remain undetected. Also by looking at the characteristics of the physical system it can be noticed that some components feature probabilistic behavior e.g. the load values or the grid conditions, modeling them as fixed components is not useful if we want to test the performance of the control algorithm under transients. Therefore, if we want to

ensure the full correctness of a system we need to use *formal methods*.

Formal methods use techniques from mathematics for checking the system behavior in all possible scenarios and Statistical Model Checking (SMC) is an extension of one of those methods. Using this approach the system will be simulated for a finite number of times. The simulation samples are used for hypothesis testing i.e. to check if the samples provide statistical evidence that the set hypothesis is valid [36]. Two types of tests can be conducted: checking if the probability to satisfy a property is within the specified threshold e.g if the property is voltage deviation $\Delta V < 5\%$, and estimation of this probability. For the first testing, hypothesis testing algorithms are used and for the latter algorithms based on Monte Carlo simulation. The Monte Carlo algorithms are enhanced to overcome the problems of estimating low probabilities and rare events.

The family of UPPAAL tools are all based on variants of Timed Automata [37]. Timed Automata are a mathematical rigorously defined formalism for specifying the timed behavior of systems. Traditional analysis of such models suffers from the problem of state space explosion; the size of problems grow exponential in the size of the input problems. A more recent development in the analysis of Timed Automata models is the introduction of SMC. These methods allow for a precise modeling of dynamic aspects of models in the form of a Network of Stochastic Timed Automata. For a formal definition of Networks of Stochastic Timed Automata we refer the reader to [37]. Here we will first give an intuitive explanation of the models by two examples.

A model consists of several Timed Automata each defining some behavior. They can synchronize with each other through the use of broadcast signals. The models can also contain clocks and continuous variables, which can progress according to differential equations. The timing intervals and delays described in the models are given a stochastic semantic. With this semantic the models can be simulated randomly. The analysis of the models consists of investigating a statistical hypothesis on the model by performing a number of independently random traces over the model. In this way a property of the model can be asserted with a given confidence interval. The confidence can be chosen by the engineer working with the models. In this fashion a low confidence can be used while creating the models in order to explore the possibilities, while a much higher probability can be selected for the final verification of the system. Contrary to traditional model checking which grows exponentially in the size of the models, statistical model checking grows sub-linearly in the size of the models and linearly with increased confidence of the results.

One of the Timed Automata templates used in this paper are shown in Fig. 2. This model is used to model a simple transient load on the system. The states of the template are referred to as locations, in order not to confuse them with the global states, which are configurations of the entire model. The left most location in the model is the initial location. This fact can be seen by having a double circle surrounding it. This location is also of the type *Committed*, which can be seen by having a C inside it. This signifies that it has a higher priority, and

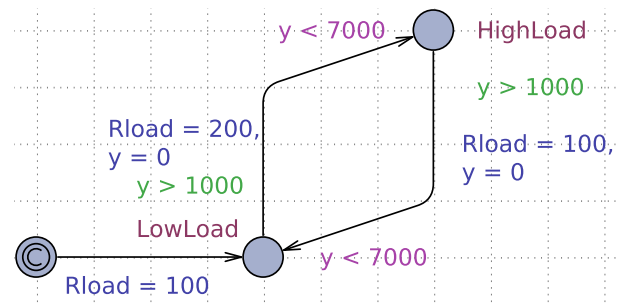

Fig. 2. Simple Timed Automata model of a changing load in UPPAAL SMC.

that no time can pass before this location has been left. In this case the feature is used as a simple initialization mechanism.

On the edge going from the initial location to the location named **LowLoad** the variable **Rload** is assigned the value 100. The template contains one clock **y** which is used to track the time since the last change in the load on the system. The invariant $y < 7000$ ensures that the change will happen after no more than 7000 time units, while the guard $y > 1000$ ensures that it will no earlier than 1000 time units. Each time unit models $1 \mu s$ in the real world. The transition has a uniform probability of occurring any time in this interval. When the transition to the **HighLoad** location occurs the **Rload** variable is set to 200 and the clock is reset to 0. The mechanism for changing back to the **LowLoad** location is identical. Thus the template models a simple transient load, where the load randomly changes between 100 and 200.

Fig. 3 models the actual controller logic of the converter. The locations **v0_1** to **v7_8** models the eight different states that the converter can be in. The model begins in the location at the bottom of the figure. This is similar to the initial location in the LoadModel also a committed location. This means that it will immediately transition to the location **v5_6**. Along this edge three assignments are performed. The values of **V_in_alpha** and **V_in_beta** are set according to the voltage generated in this configuration. The variable **active_control** is used mainly as a way of outputting the actual control state of the converter in traces of the system. The same pattern of assignment is followed along all the edges going from the location **left** to each of the locations **v0_1** to **v7_8**. The controller will spend of its clock time in one of these locations. Each $25 \mu s$ another template will generate a *tick* event thus synchronizing with this template and forcing it into the **right** location. Since this is a committed location it will immediately move to the **left** location while evaluating two functions during this transition. These functions are inside the UPPAAL model and they are specified in a subset of C. The first function evaluates the future cost of the different switching configurations, and the second one selects the one with the lowest cost and set the variable **minControl** accordingly. This is then used in the guard of the next edges thus forcing the model into the right switching state.

The system contains four other templates which will not be discussed in details here: **Tick**, **Sampler**, **PhysicalSystem** and **SimulationOutput**.

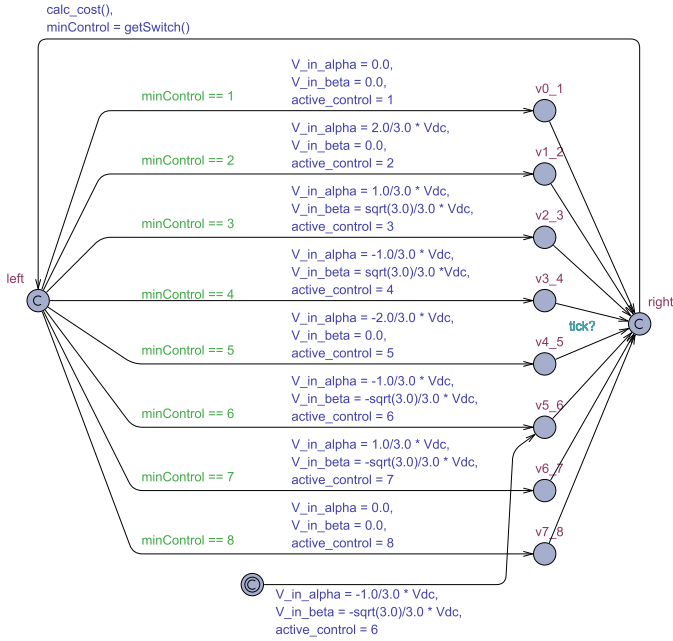

Fig. 3. Controller hybrid automata model in UPPAAL SMC.

V. SIMULATION RESULTS

A discrete benchmark model of the previously described system was created in Matlab Simulink. The results obtained from the simulation model will be used to validate the quality of model created in the UPPAAL SMC toolbox. Parameters of the simulation model are presented in Table II.

TABLE II
SYSTEM PARAMETERS

Parameter	Value
DC link voltage	$V_{dc} = 700$ V
Output filter parameters	$L_f = 2.4$ mH, $C_f = 25$ μ F
Linear load	$R_{load} = 48$ Ω , $L_{load} = 40$ mH
Non-linear load	$R_{load} = 230$ Ω , $C_{load} = 1100$ μ F
Reference voltage and frequency	$V_{c\ ref\ rms} = 400$ V, $f_{ref} = 50$ Hz
Sampling time	$T_s = 25$ μ s

Because of the nature of the FCS-MPC algorithm used in this paper, which does not have a modulator, the switching frequency is variable. This makes the precise filter parameter selection difficult as standard linear control theory cannot be used to quantify the switching ripples. Finding the right methodology to analytically calculate the parameters is still an open research question [13], [20], [38]. On the other hand, we can quantify the effects of the filter around the fundamental harmonic. There are some guidelines regarding the maximum filter values as presented in [39] that were taken into consideration. However, the switching ripple attenuation capability of this filter depends also on the switching frequency. To this end, other authors have used larger filters than what is advised by these limits [40], [41]. While selecting the filter parameters, we have also taken into account comparable systems reported in the literature, that regulate voltage on the standalone load

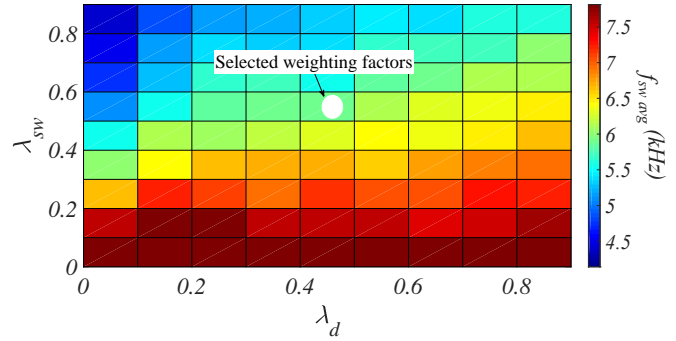

Fig. 4. Influence of weighting factor selection on output voltage THD factor (%).

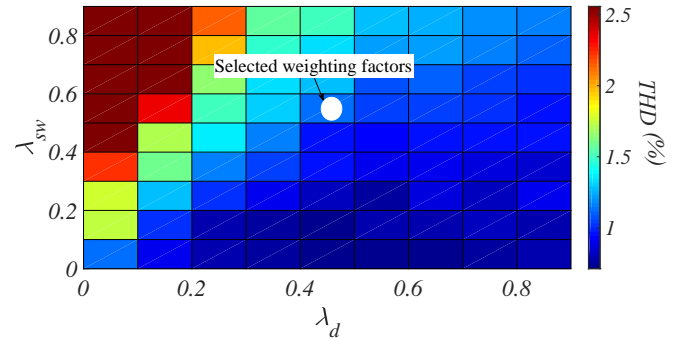

Fig. 5. Influence of weighting factor selection on average converter switching frequency (kHz).

operating at approximately the same power level and use comparable switching frequency, so that a fair comparison of different control methods can be made [41]–[44]. Commercial availability of the filter was also one of the aspects that was taken into consideration. The filter from manufacturer Schaffner with the inductance value of 2.4 mH was selected. The inductance value of this filter was larger than advised in the [39], but comparable to the ones used in [40], [41]. For the filter capacitance it is recommended that the maximum value is below the 5% of the base capacitance because the capacitor value is limited by the decrease of the power factor at rated power, therefore 25 μ F capacitors were selected. The system has a variable switching frequency, hence, only the average switching frequency, that can be calculated by filtering the expression given in equation (5), could be specified. If both weighting factors are set to 0, the obtained output voltage THD is 1.1%, which complies with the IEC UPS standard 62040 and the $f_{sw\ avg}$ was around 9 kHz. It was of interest to investigate if it is possible to achieve the comparable level of THD at lower $f_{sw\ avg}$ by using a proper combination of the weighting factors in the cost function. For this purpose, parameter sweep simulations were performed in Matlab for different values of the weighting factors in the cost function and analyzed afterwards to see which combination would present the output voltage THD around 1.1% and have a lower $f_{sw\ avg}$. The results of such parameter sweep are presented in Fig. 4 and Fig. 5. As it can be seen, with the selected combination of weighting factors $\lambda_{sw} = 0.5$ and $\lambda_d = 0.4$, we obtained an

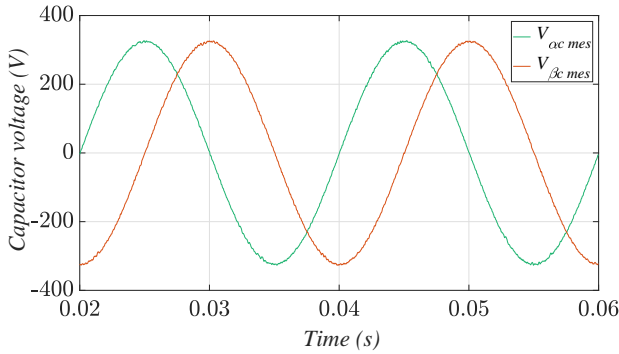

Fig. 6. Simulated output voltage in α - β frame in the 2L-VSC Simulink model.

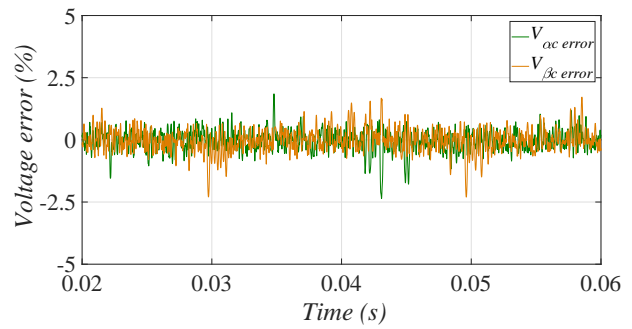

Fig. 9. Voltage reference tracking error in α - β frame in the 2L-VSC Simulink model, 130% L_f .

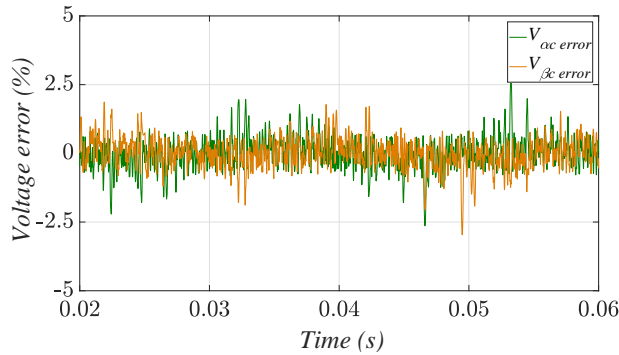

Fig. 7. Voltage reference tracking error in α - β frame in the 2L-VSC Simulink model, nominal $L_f C_f$ parameters.

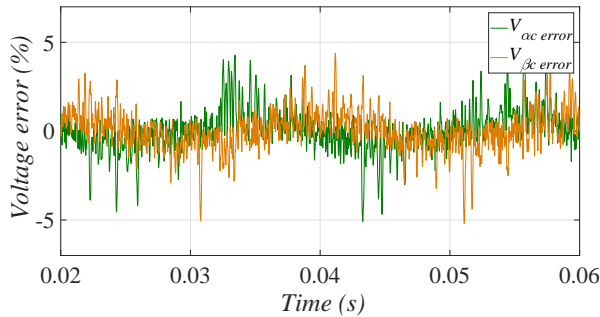

Fig. 8. Voltage reference tracking error in α - β frame in the 2L-VSC Simulink model, 70% L_f .

$f_{sw_{avg}}$ of 6 kHz and output voltage THD of 1.1%, which is the same as if both weighting factors are set to 0. Therefore, the $f_{sw_{avg}}$ of 6 kHz with aforementioned weighting factor settings was selected for all the experiments.

If the cost function was limited just to include switching frequency minimization $\lambda_{sw} = 0.2$ will offer a good compromise of a low THD and reduction of $f_{sw_{avg}}$ from 9 kHz to 6.5 kHz. Fig. 6 and Fig. 7 present the measured output voltage and voltage reference tracking error in $\alpha\beta$ -frame in steady state for FCS-MPC cost function. It can be observed that the implemented control algorithm produces an output voltage that is closely following the reference values.

The robustness of the control algorithm against parameter variations is also one of the key indicators of the control

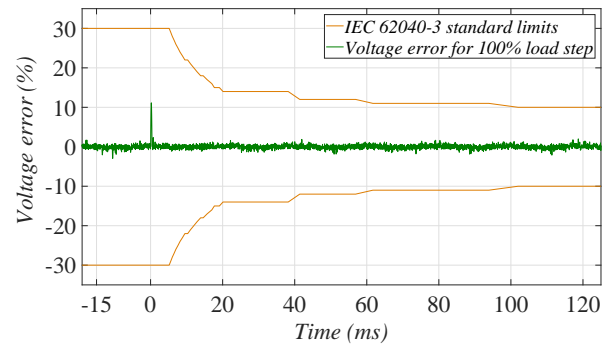

Fig. 10. Output voltage amplitude error during 100% step change of linear load in the 2L-VSC Simulink model ($R_{load} = 0 \rightarrow 48\Omega$).

algorithm performance. In Fig. 8 and Fig. 9 the impact of deviations of $\pm 30\%$ on the rated values of filter inductance were analyzed. Similar tests for variation of the converter output filter parameters have been performed in [45] for sliding mode control algorithm with Kalman filter, in [41] for a combination of robust control, state estimator, and linear matrix inequality (LMI) optimizations, and in [46] for a linear single current loop control with hybrid damper. As it can be seen from obtained results the overestimation and underestimation of the filter values didn't significantly effect the steady state performance of the converter which proves that the resistance to parameter variations is comparable to [41], [45], [46]. For a more detailed experimental study on parameter variation effects for FCS-MPC operated converters for UPS the reader is referred to [7] where it is demonstrated that stability is not lost even under heavy mismatch between the model parameters used by the algorithm and those in the experimental set-up. The dynamic performance of the UPS standard is defined in the IEC Standard 62040 for 0-100% step load change for the most critical and sensitive loads. In Fig. 10 results can be observed for the linear load step change. Similar test was performed in [44] for linear cascaded control on a set-up with comparable physical parameters. By comparing the results it can be noted that both control methods comply with the standard, however the converter system controlled by the FCS-MPC showed a much faster response time.

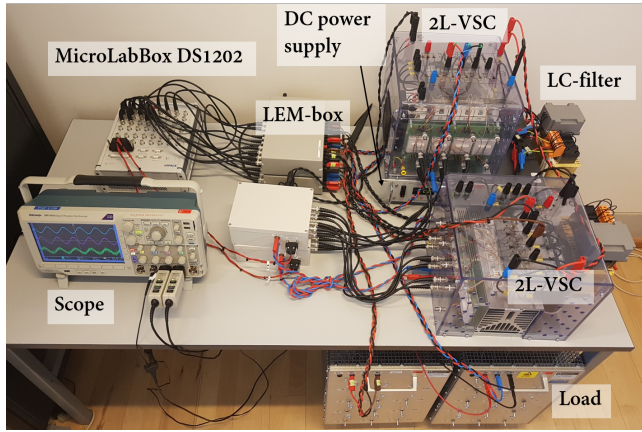

Fig. 11. Experimental set-up for verification of the FCS-MPC algorithm on the 2L-VSC.

VI. EXPERIMENTAL RESULTS

The FCS-MPC algorithm was also verified on an experimental set-up equivalent to the Simulink model as shown in Fig. 11. The set-up includes Semikron Power Electronics Teaching Unit, MicroLabBox DS1202 PowerPC DualCore 2 GHz processor board and DS1302 I/O board from dSpace. The execution time of the algorithm is around $3 \mu\text{s}$. Such a low time was achieved because the discretization of the converter model is done offline i.e. the system matrixes in (1) are calculated prior to execution of the controller. On the other hand, most of the turn-around time is spent on the A/D conversion of the measurement channels. Since dSPACE's A/D converters have the sampling rate of 1 MSPS, the time needed to sample one channel is around $1 \mu\text{s}$. Therefore, for all measurement channels, this gives approximately $12 \mu\text{s}$ for A/D conversion. When this is added to $3 \mu\text{s}$ for algorithm execution, the total turnaround time is $15 \mu\text{s}$. It is also worth noticing that standard industrial micro controllers could perform the A/D conversion much faster e.g. TMS320F28377 samples at a rate of 3.5 MSPS which means the conversion would be three times faster while the execution time of the algorithm would not change significantly. To compensate this delay of approximately $15 \mu\text{s}$ the predicted values are calculated one step further ahead and applied at the beginning of the next time sampling interval as proposed in [31].

Fig. 12 shows the measured filter capacitor voltage from experimental set-up for three different types of load a) linear R_{load} , b) linear RL_{load} and c) non-linear load (diode rectifier with RC_{load}). The THD was calculated up to the Nyquist frequency for measured $v_{c\ abc}$, to include the wide frequency spectrum of FCS-MPC. The obtained measurements presented acceptable control performance in steady state and quick response during transient load change in Fig. 12(e) for R_{load} and Fig. 12(f) for RL_{load} , and as well for step reference change in Fig. 12(d).

VII. ANALYTICAL PERFORMANCE VERIFICATION

For the purpose of performance verification of the FCS-MPC algorithm, the system was modeled using UPPAAL SMC. In the UPPAAL SMC verifier system, currents and voltages

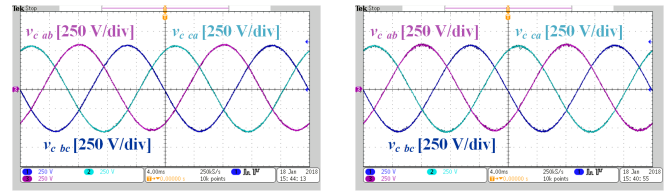

(a) Three phase capacitor voltage $v_{c\ abc}$ for R_{load} (48Ω), Voltage THD: 1.15%.

(b) Three phase capacitor voltage $v_{c\ abc}$ for RL_{load} (48Ω , 40 mH), Voltage THD: 1.35%.

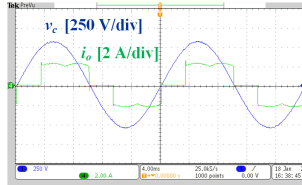

(c) Capacitor voltage $v_{c\ ab}$ and load current $i_{o\ a}$ for non-linear load, Voltage THD: 1.35%.

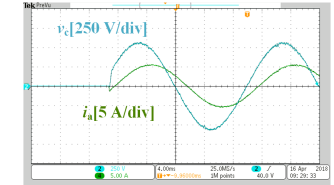

(d) Capacitor voltage $v_{c\ ab}$ and load current $i_{o\ a}$ for step change with R_{load} .

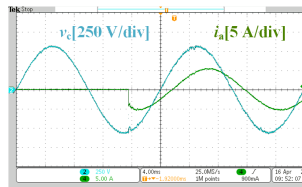

(e) Capacitor voltage and load current $v_{c\ ab}$ and $i_{o\ a}$ for a step load change (linear $R_{load} = 0 \rightarrow 48\Omega$).

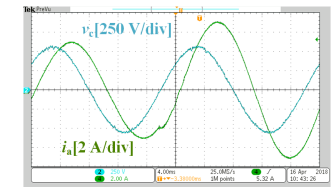

(f) Capacitor voltage and load current $v_{c\ ab}$ and $i_{o\ a}$ for a step load change (linear RL_{load} , $R_{load} = 48 \rightarrow 34\Omega$).

Fig. 12. Experimental validation of the FCS-MPC algorithm on the 2L-VSC.

can be presented graphically. An example of the output voltage waveform is shown in Fig. 13 for linear load and cost function (2), and another example is shown in Fig. 15 for the load current during the transient. In Fig. 14 for the linear load and cost function (2) it can be observed that the reference tracking ability of the algorithm was proved to be satisfying and matching the performance of simulation and experimental model. Therefore, it is confirmed that the modeling was correct and that the model can be used for analytical performance validation during transient load. The algorithm's analytical performance was assessed through two queries for a time interval of 40 ms:

$$diff = (v_{c\alpha}^* - v_{c\alpha}^m)^2 + (v_{c\beta}^* - v_{c\beta}^m)^2 \quad (6)$$

where $v_{c\alpha}^*$ and $v_{c\beta}^*$ represent the real and imaginary parts of reference voltage vector $v_c^*(k)$, $v_{c\alpha}^m$ and $v_{c\beta}^m$ are the values of measured output voltage $v_c^m(k)$ and the second query was the simple moving average value SMA of the difference calculated on $n = 10$ sample subsets.

$$SMA = SMA_{prev} + \frac{diff_M}{n} - \frac{diff_{M-n}}{n} \quad (7)$$

The load value is changing stochastically during the time interval, through several runs all possible transients are evaluated in the queries. An example of the $i_{o\alpha\beta}$ waveform in one simulation run during the query evaluation is shown in Fig. 15.

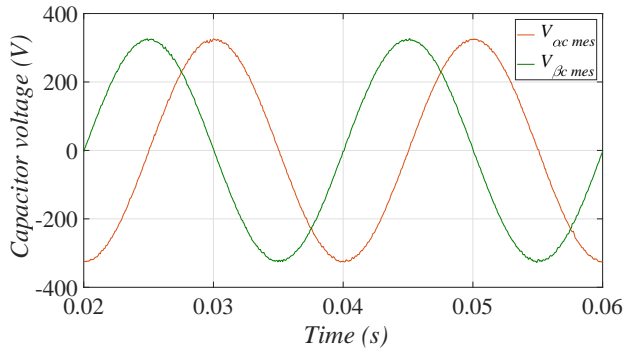

Fig. 13. Simulated output voltage in α - β frame in the 2L-VSC UPPAAL SMC model.

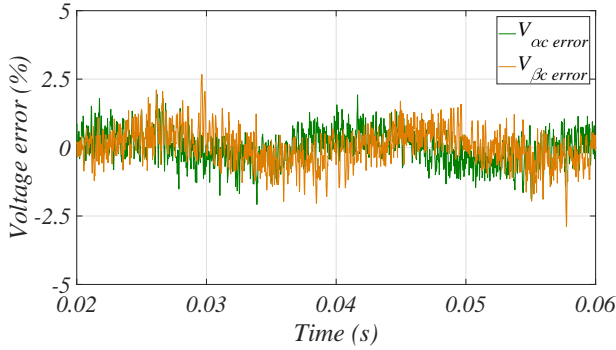

Fig. 14. Voltage reference tracking error in α - β frame in the 2L-VSC UPPAAL SMC model.

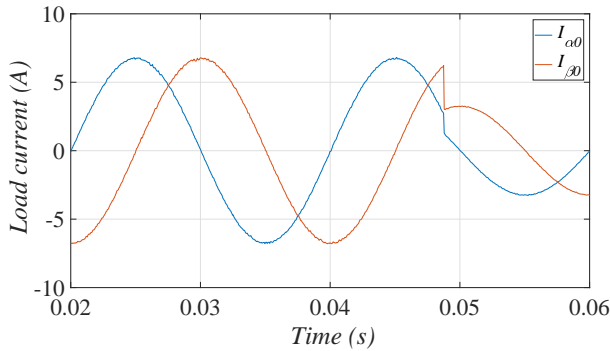

Fig. 15. Load current under transient load change ($R = 48 \Omega \rightarrow 100 \Omega$) in the 2L-VSC UPPAAL SMC model.

To demonstrate the influence of each secondary objective in the algorithm's cost function a case without secondary objectives and only switching frequency minimization objective were as well evaluated. Table III shows the summary of tested probabilities for transient load with parameter uncertainty introduced into the model as false estimation of L_f . Both overestimation and underestimation of the filter inductance were taken into account as in [41], [45], [46]. The uncertainty of estimation process was set to $\epsilon = 0.05$. The queries were tested for $\lambda_{sw} = \lambda_d = 0$ with output voltage reference tracking as primary objective, $\lambda_{sw} = 0.2$ with switching frequency minimization applied as secondary objective and $\lambda_{sw} = 0.5$ $\lambda_d = 0.4$ where derivative of voltage reference trajectory was tracked. After the simulation run is completed the verifier

toolbox will also provide the number of performed runs. For query probabilities close to 0 or 1, the number of runs necessary for assessment is low and it can be concluded that the events in those queries are not likely to happen (0) or are highly likely to happen (1).

By analyzing the results in Table III the influence of weighting factor selection and parameter uncertainty on voltage tracking reference performance can be detected. The weighting factors obtained in the parameter sweep were proved to benefit the performance of reference tracking as they presented a higher probability of minimal voltage error during transients and parameter uncertainty. This positive effect was even more noticeable in case of R_{load} . Introduced parameter uncertainty in the model didn't significantly lower the reference tracking performance for R_{load} . In the case of the $\lambda_{sw} = \lambda_d = 0$ for R_{load} there was a drop of 5% as seen in the queries for $diff < 10\%$ without parameter error (-30%) and $diff < 15\%$ with parameter error. When the model was tested with R_{load} the drop in the performance was more evident e.g for $\lambda_{sw} = \lambda_d = 0$ with underestimated parameter query $diff < 15\%$ has a very low probability. The case $\lambda_{sw} = 0.5$, $\lambda_d = 0.4$ demonstrated robustness of the algorithm by not showing any significant performance drop with a parameter error in the model for both load types. As expected the case with $\lambda_{sw} = 0.2$, $\lambda_d = 0$ showed a more significant drop of performance compared to the other two cases. This can be explained by the fact that the priority of this cost function lies in switching frequency minimization so the reference tracking performance will be more affected by the introduced parameter error in the model. The underestimation of filter inductance has a larger influence on the reference tracking performance for $\lambda_{sw} = 0.2$ $\lambda_d = 0$ while if the filter inductance is overestimated the effect on the performance is very low.

VIII. CONCLUSION

In this paper a new approach to analytical performance validation of the FCS-MPC algorithm was demonstrated. The approach is based on powerful tools from statistics and can be used to successfully validate the behavior of the control algorithm. The transition from a Simulink based model to the model used in UPPAAL SMC is based on the fact that the discrete system of the 2L-VCS with FCS-MPC algorithm can be represented as a network of stochastic automata. Time, which is usually used to drive the automaton is supplemented with system voltages and currents. The discrete converter states are the states of the automaton while the calculated predictions of voltages and currents, products of the cost function minimization, are defining the next transition state. It was validated in the paper that this type of model will provide the same behavior as the Simulink model. UPPAAL SMC offers a benefit compared to the Simulink model, a simple analytical verification using the statistics tools. Therefore the probability of certain events occurring in the system can be checked very simply using Monte Carlo simulation in the form of a query.

Queries used for checking the robustness were based on the reference tracking ability of the system under transient load

TABLE III
QUERY PROBABILITY RESULTS OBTAINED FROM UPPAAL SMC TOOLBOX VERIFIER FOR R AND RL LOAD

Query	Parameter uncertainty	Probability ($\lambda_{sw} = \lambda_d = 0$)		Probability ($\lambda_{sw} = 0.2, \lambda_d = 0$)		Probability ($\lambda_{sw} = 0.5, \lambda_d = 0.4$)	
		R	RL	R	RL	R	RL
		$diff < 8\%$	0	0.45 – 0.55	0.32 – 0.42	0 – 0.1	0 – 0.1
$diff < 10\%$	0	0.89 – 0.99	0.89 – 0.99	0.19 – 0.29	0.09 – 0.19	0.9 – 1	0.9 – 1
$diff < 12\%$	0	0.9 – 1	0.9 – 1	0.79 – 0.89	0.58 – 0.68	0.9 – 1	0.9 – 1
$diff < 15\%$	0	0.9 – 1	0.9 – 1	0.9 – 0.99	0.9 – 0.99	0.9 – 1	0.9 – 1
$diff < 10\%$	-30%	0 – 0.1	0 – 0.1	0 – 0.1	0 – 0.1	0.78 – 0.88	0.73 – 0.83
$diff < 12\%$	-30%	0.17 – 0.27	0 – 0.1	0 – 0.1	0 – 0.1	0.9 – 1	0.9 – 1
$diff < 15\%$	-30%	0.81 – 0.91	0.08 – 0.18	0.47 – 0.57	0.22 – 0.32	0.9 – 1	0.9 – 1
$diff < 10\%$	30%	0.9 – 1	0.9 – 1	0.8 – 0.9	0.65 – 0.75	0.9 – 1	0.9 – 1
$SMA < 8\%$	0	0.52 – 0.62	0.35 – 0.45	0 – 0.1	0 – 0.1	0.9 – 1	0.9 – 1
$SMA < 10\%$	0	0.9 – 1	0.82 – 0.92	0.33 – 0.43	0.13 – 0.23	0.9 – 1	0.9 – 1
$SMA < 12\%$	0	0.9 – 1	0.9 – 1	0.79 – 0.89	0.64 – 0.74	0.9 – 1	0.9 – 1
$SMA < 10\%$	-30%	0.01 – 0.1	0 – 0.1	0 – 0.1	0 – 0.1	0.82 – 0.91	0.76 – 0.86
$SMA < 12\%$	-30%	0.24 – 0.34	0 – 0.1	0 – 0.1	0 – 0.1	0.9 – 1	0.9 – 1
$SMA < 15\%$	-30%	0.81 – 0.91	0.1 – 0.2	0.52 – 0.62	0.34 – 0.44	0.9 – 1	0.9 – 1
$SMA < 10\%$	30%	0.9 – 1	0.9 – 1	0.84 – 0.94	0.69 – 0.79	0.9 – 1	0.9 – 1

changes and with parameter uncertainties in the system. The results demonstrated high robustness of the algorithm and how the right choice of the weighting factors in the cost function will positively affect it. During the evaluation, no significant degradation of reference tracking was found during transients nor under model parameter uncertainty. Even under the most difficult conditions including error in the prediction model, the difference between the reference and the control variable stayed below 10%.

Statistical model checking has the potential to be the new powerful tool for performance evaluation of FCS-MPC algorithms in different power converter topologies. There are many possibilities for future work with focus on analytical performance evaluation of other MPC algorithms and more complex load and system models. Further development of the approach can be of great significance for the power electronics industry as it will benefit the application of the FCS-MPC algorithms.

REFERENCES

- [1] J. I. Leon, S. Kouro, L. G. Franquelo, J. Rodriguez, and B. Wu, "The essential role and the continuous evolution of modulation techniques for voltage-source inverters in the past, present, and future power electronics," *IEEE Trans. Ind. Electron.*, vol. 63, no. 5, pp. 2688–2701, May. 2016.
- [2] B. Stellato, T. Geyer, and P. J. Goulart, "High-speed finite control set model predictive control for power electronics," *IEEE Trans. Power Electron.*, vol. 32, no. 5, pp. 4007–4020, May. 2017.
- [3] Z. Zhang, H. Fang, F. Gao, J. Rodriguez, and R. Kennel, "Multiple-vector model predictive power control for grid-tied wind turbine system with enhanced steady-state control performance," *IEEE Trans. Ind. Electron.*, vol. 64, no. 8, pp. 6287–6298, Aug. 2017.
- [4] S. C. Ferreira and *et al.*, "Finite control set model predictive control for dynamic reactive power compensation with hybrid active power filters," *IEEE Trans. Ind. Electron.*, vol. 65, no. 3, pp. 2608–2617, Mar. 2018.
- [5] M. B. Shadmand, M. Mosa, R. S. Balog, and H. Abu-Rub, "Model predictive control of a capacitorless matrix converter-based STATCOM," *IEEE J. Emerg. Sel. Topics Power Electron.*, vol. 5, no. 2, pp. 796–808, Jun. 2017.
- [6] S. Sajadian and R. Ahmadi, "Model predictive control of dual-mode operations z-source inverter: Islanded and grid-connected," *IEEE Trans. Power Electron.*, vol. 33, no. 5, pp. 4488–4497, May. 2018.
- [7] T. Dragicevic, "Model predictive control of power converters for robust and fast operation of AC microgrids," *IEEE Trans. Power Electron.*, vol. 33, no. 7, pp. 6304–6317, Jul. 2018.
- [8] R. Vargas, U. Ammann, and J. Rodriguez, "Predictive approach to increase efficiency and reduce switching losses on matrix converters," *IEEE Trans. Power Electron.*, vol. 24, no. 4, pp. 894–902, Apr. 2009.
- [9] V. Smidl, S. Janous, and Z. Peroutka, "Frequency spectrum shaping using finite control set MPC with LQ lookahead," in *Proc. Workshop PRECEDE*, pp. 44–48, Oct. 2015.
- [10] R. P. Aguilera and *et al.*, "Selective harmonic elimination model predictive control for multilevel power converters," *IEEE Trans. Power Electron.*, vol. 32, no. 3, pp. 2416–2426, Mar. 2017.
- [11] L. Wang and *et al.*, "A finite control set model predictive control method for matrix converter with zero common-mode voltage," *IEEE J. Emerg. Sel. Topics Power Electron.*, vol. 6, no. 1, pp. 327–338, Mar. 2018.
- [12] P. Kakosimos and H. Abu-Rub, "Predictive control of a grid-tied cascaded full-bridge NPC inverter for reducing high-frequency common-mode voltage components," *IEEE Trans. Ind. Informat.*, vol. In press, 2018.
- [13] S. Kouro, M. A. Perez, J. Rodriguez, A. M. Llor, and H. A. Young, "Model predictive control: MPC's role in the evolution of power electronics," *IEEE Ind. Electron. Mag.*, vol. 9, no. 4, pp. 8–21, Dec. 2015.
- [14] P. Cortes, M. P. Kazmierkowski, R. M. Kennel, D. E. Quevedo, and J. Rodriguez, "Predictive control in power electronics and drives," *IEEE Trans. Ind. Electron.*, vol. 55, no. 12, pp. 4312–4324, Dec. 2008.
- [15] S. Vazquez and *et al.*, "Model predictive control for single-phase NPC converters based on optimal switching sequences," *IEEE Trans. Ind. Electron.*, vol. 63, no. 12, pp. 7533–7541, Dec. 2016.
- [16] A. A. Ahmed, B. K. Koh, and Y. I. Lee, "A comparison of finite control set and continuous control set model predictive control schemes for speed control of induction motors," *IEEE Trans. Ind. Inf.*, vol. 14, no. 4, pp. 1334–1346, Apr. 2018.
- [17] M. Norambuena, H. Yin, S. Dieckerhoff, and J. Rodriguez, "Improved finite control set model predictive control with fixed switching frequency for three phase NPC converter," in *Proc. PCIM Europe*, pp. 1–8, May. 2016.
- [18] M. Preindl and S. Bolognani, "Comparison of direct and PWM model predictive control for power electronic and drive systems," in *Proc. IEEE APEC*, pp. 2526–2533, Mar. 2013.
- [19] S. Vazquez and *et al.*, "Model predictive control: A review of its applications in power electronics," *IEEE Ind. Electron. Mag.*, vol. 8, no. 1, pp. 16–31, Mar. 2014.

- [20] S. Vazquez, J. Rodriguez, M. Rivera, L. G. Franquelo, and M. Norambuena, "Model predictive control for power converters and drives: Advances and trends," *IEEE Trans. Ind. Electron.*, vol. 64, no. 2, pp. 935–947, Feb. 2017.
- [21] V. Yaramasu and B. Wu, *Model Predictive Control of Wind Energy Conversion Systems*, ser. IEEE Press Series on Power Engineering, Wiley, 2016.
- [22] J. Rawlings and D. Mayne, *Model Predictive Control: Theory and Design*. Nob Hill Pub., 2009.
- [23] R. N. Fard, H. Nademi, and L. Norum, "Analysis of a modular multilevel inverter under the predicted current control based on finite-control-set strategy," in *Proc. EPECS*, pp. 1–6, Oct. 2013.
- [24] V. Yaramasu, M. Rivera, B. Wu, and J. Rodriguez, "Model predictive current control of two-level four-leg inverters: part i: Concept, algorithm, and simulation analysis," *IEEE Trans. Power Electron.*, vol. 28, no. 7, pp. 3459–3468, Jul. 2013.
- [25] J. Rodriguez and *et al.*, "Predictive current control of a voltage source inverter," *IEEE Trans. Ind. Electron.*, vol. 54, no. 1, pp. 495–503, Feb. 2007.
- [26] H. A. Young, M. A. Perez, J. Rodriguez, and H. Abu-Rub, "Assessing finite-control-set model predictive control: A comparison with a linear current controller in two-level voltage source inverters," *IEEE Ind. Electron. Mag.*, vol. 8, no. 1, pp. 44–52, Mar. 2014.
- [27] R. P. Aguilera and D. E. Quevedo, "Predictive control of power converters: Designs with guaranteed performance," *IEEE Trans. Ind. Inform.*, vol. 11, no. 1, pp. 53–63, Feb. 2015.
- [28] R. P. Aguilera and D. E. Quevedo, "On stability and performance of finite control set MPC for power converters," in *Proc. Workshop PRECEDE*, pp. 55–62, Oct. 2011.
- [29] R. P. Aguilera and D. E. Quevedo, "On stability of finite control set MPC strategy for multicell converters," in *Proc. IEEE ICIT*, pp. 1277–1282, Mar. 2010.
- [30] M. P. Akter, S. Mekhilef, N. M. L. Tan, and H. Akagi, "Modified model predictive control of a bidirectional AC-DC converter based on lyapunov function for energy storage systems," *IEEE Trans. Ind. Electron.*, vol. 63, no. 2, pp. 704–715, Feb. 2016.
- [31] J. Rodriguez and P. Cortes, *Predictive Control of Power Converters and Electrical Drives*, ser. Wiley - IEEE. Wiley, 2012.
- [32] "IEC standard for uninterruptible power systems (UPS) - part 3," *IEC 62040-3:2011*, no. 2, pp. 1–214, Mar. 2011.
- [33] A. David, K. G. Larsen, A. Legay, and M. Mikučionis, "Schedulability of herschel revisited using statistical model checking," *Int. J. Softw. Tools Technol. Transf.*, vol. 17, no. 2, pp. 187–199, Apr. 2015.
- [34] A. Boudjadar and *et al.*, "Statistical and exact schedulability analysis of hierarchical scheduling systems," *Science of Computer Programming*, vol. 127, pp. 103–130, 5 2016.
- [35] K. G. Larsen, M. Mikučionis, M. Muñoz, J. Srba, and J. H. Taankvist, *Online and Compositional Learning of Controllers with Application to Floor Heating*, pp. 244–259. Springer Berlin Heidelberg, 2016.
- [36] K. G. Larsen and A. Legay, *On the Power of Statistical Model Checking*, pp. 843–862. Springer International Publishing, 2016.
- [37] A. David and *et al.*, "Uppaal SMC tutorial," *Int. J. Softw. Tools Technol. Transf.*, vol. 17, no. 4, pp. 397–415, Aug. 2015.
- [38] N. Panten, N. Hoffmann, and F. W. Fuchs, "Finite control set model predictive current control for grid-connected voltage-source converters with LCL filters: A study based on different state feedbacks," *IEEE Trans. Power Electron.*, vol. 31, no. 7, pp. 5189–5200, Jul. 2016.
- [39] M. Liserre, F. Blaabjerg, and S. Hansen, "Design and control of an LCL-filter-based three-phase active rectifier," *IEEE Trans. Ind. Appl.*, vol. 41, no. 5, pp. 1281–1291, Sep. 2005.
- [40] A. Reznik, M. G. Simoes, A. Al-Durra, and S. M. Muyeen, "LCL filter design and performance analysis for grid-interconnected systems," *IEEE Trans. Ind. Appl.*, vol. 50, no. 2, pp. 1225–1232, Mar. 2014.
- [41] J. S. Lim, C. Park, J. Han, and Y. I. Lee, "Robust tracking control of a three-phase DC-AC inverter for UPS applications," *IEEE Trans. Ind. Electron.*, vol. 61, no. 8, pp. 4142–4151, Aug. 2014.
- [42] P. Cortes and *et al.*, "Model predictive control of an inverter with output LC filter for UPS applications," *IEEE Trans. Ind. Electron.*, vol. 56, no. 6, pp. 1875–1883, Jun. 2009.
- [43] S. Vazquez, A. Marquez, J. I. Leon, L. G. Franquelo, and T. Geyer, "FCS-MPC and observer design for a VSI with output LC filter and
- [44] F. de Bosio, L. A. de Souza Ribeiro, F. D. Freijedo, M. Pastorelli, and J. M. Guerrero, "Effect of state feedback coupling and system delays on the transient performance of stand-alone VSI with LC output filter," *IEEE Trans. Ind. Electron.*, vol. 63, no. 8, pp. 4909–4918, Aug. 2016.

sinusoidal output currents," in *Proc. IEEE CPE-POWERENG*, pp. 677–682, Apr. 2017.

- [45] R. Guzman, L. G. de Vicuna, M. Castilla, J. Miret, and H. Martin, "Variable structure control in natural frame for three-phase grid-connected inverters with LCL filter," *IEEE Trans. Power Electron.*, vol. 33, no. 5, pp. 4512–4522, May. 2018.
- [46] Y. Liu and *et al.*, "An efficient and robust hybrid damper for LCL- or LLCL- based grid-tied inverter with strong grid-side harmonic voltage effect rejection," *IEEE Trans. Ind. Electron.*, vol. 63, no. 2, pp. 926–936, Feb. 2016.



Mateja Novak (S'17) received the M.Sc. degree in Electrical Engineering and Information Technology from Zagreb University, Croatia, in 2014. She is currently working toward the Ph.D. degree in power electronics at Aalborg University, Denmark. Her research interests include finite control set model predictive control, multilevel converters, statistical model checking and renewable energy systems.



Ulrik Nyman is an Associate Professor at the Department of Computer Science at Aalborg University. He did his PhD Thesis on the topic of Modal Transition Systems as the Basis for Interface Theories and Product Lines under the supervision of Professor Kim G. Larsen.

His research interests lies within formal methods such as: Interface Theories, Model Checking, Compositional Verification and Software Verification. Since then he has worked with applying formal methods to different application

domains. This includes model based schedulability analysis of embedded systems. He is currently the PI for the DFF research project Compositional Verification of Real-time MULTI-CORE SAFETY Critical Systems.



Tomislav Dragicevic (S'09-M'13-SM'17) received the M.E.E. and the industrial Ph.D. degree from the Faculty of Electrical Engineering, Zagreb, Croatia, in 2009 and 2013, respectively. From 2013 until 2016 he has been a Postdoctoral research associate at Aalborg University, Denmark. From March 2016 he is an Associate Professor at Aalborg University, Denmark.

His principal field of interest is overall system design of autonomous and grid connected DC and AC microgrids, and application of advanced

modeling and control concepts to power electronic systems. He has authored and co-authored more than 120 technical papers in his domain of interest and is currently editing a book in the field. He serves as an Associate Editor in the IEEE TRANSACTIONS ON INDUSTRIAL ELECTRONICS and in the Journal of Power Electronics.



Frede Blaabjerg (S'86-M'88-SM'97-F'03) was with ABB-Scandia, Randers, Denmark, from 1987 to 1988. From 1988 to 1992, he was a Ph.D. Student with Aalborg University, Aalborg, Denmark. He became an Assistant Professor in 1992, Associate Professor in 1996, and Full Professor of power electronics and drives in 1998. His current research interests include power electronics and its applications such as in wind turbines, PV systems, reliability, harmonics and adjustable speed drives.

He has received 18 IEEE Prize Paper Awards, the IEEE PELS Distinguished Service Award in 2009, the EPE-PEMC Council Award in 2010, the IEEE William E. Newell Power Electronics Award 2014 and the Villum Kann Rasmussen Research Award 2014. He was an Editor-in-Chief of the IEEE TRANSACTIONS ON POWER ELECTRONICS from 2006 to 2012. He was nominated in 2014, 2015 and 2016 by Thomson Reuters to be between the most 250 cited researchers in Engineering in the world.