



AALBORG UNIVERSITY
DENMARK

Aalborg Universitet

The Primary Frequency Control Method of Tidal Turbine Based on Pitch Control

Li, Pengfei; Hu, Weihao; Hu, Rui; Chen, Zhe

Published in:
Energy Procedia

DOI (link to publication from Publisher):
[10.1016/j.egypro.2018.04.035](https://doi.org/10.1016/j.egypro.2018.04.035)

Creative Commons License
CC BY-NC-ND 4.0

Publication date:
2018

Document Version
Publisher's PDF, also known as Version of record

[Link to publication from Aalborg University](#)

Citation for published version (APA):
Li, P., Hu, W., Hu, R., & Chen, Z. (2018). The Primary Frequency Control Method of Tidal Turbine Based on Pitch Control. *Energy Procedia*, 145, 199-204. <https://doi.org/10.1016/j.egypro.2018.04.035>

General rights

Copyright and moral rights for the publications made accessible in the public portal are retained by the authors and/or other copyright owners and it is a condition of accessing publications that users recognise and abide by the legal requirements associated with these rights.

- Users may download and print one copy of any publication from the public portal for the purpose of private study or research.
- You may not further distribute the material or use it for any profit-making activity or commercial gain
- You may freely distribute the URL identifying the publication in the public portal -

Take down policy

If you believe that this document breaches copyright please contact us at vbn@aub.aau.dk providing details, and we will remove access to the work immediately and investigate your claim.



Applied Energy Symposium and Forum, Renewable Energy Integration with Mini/Microgrids,
REM 2017, 18–20 October 2017, Tianjin, China

The Primary Frequency Control Method of Tidal Turbine Based on Pitch Control

Pengfei Li^{a*}, Weihao Hu^a, Rui Hu^a and Zhe Chen^{a †}

^aDepartment of Energy Technology, Aalborg University, Pontoppidanstraede 101, 9220 Aalborg East, Denmark

Abstract

Due to the increasing penetration level of tidal power in power system, the tidal turbines can provide less frequency support than conventional generators due to their small rotor mass. This makes the power system with low inertia and cause frequency problem. This paper presents a simulation model of a tidal power farm based on a MW-level variable speed tidal turbine with doubly-fed induction generator (DFIG) developed in the simulation tool of Matlab/Simulink. According to the reserve capacity required for primary frequency control, a de-loading control method is proposed in this paper to resolve the issue of primary frequency control via tidal power plant. Based on the analysis method of the frequency control characteristics of DFIGs, it is proposed by improved variable pitch control method. The control strategy, which is based on pitch control system of tidal turbine, is proposed in order to participate into primary frequency regulation of power system. Simulation results show that the proposed control strategy is effective means the tidal turbines with DFIG generators could providing frequency support for power system when they are working under the de-loading condition in this paper.

Copyright © 2018 The Authors. Published by Elsevier Ltd.

Selection and peer-review under responsibility of the scientific committee of the Applied Energy Symposium and Forum, Renewable Energy Integration with Mini/Microgrids, REM 2017

Keywords: tidal turbine, pitch control, primary frequency control, DFIG, de-loading operation

1. Introduction

In recent years, because of the rapid developments of commerce and industry, the energy demands grow significantly. The world has to face energy-deficiency issues, due to the traditional fossil-fuel resources are rather limited. Thus, some countries are eager to search the alternative energies. Ocean-powered technologies are in their infancy. With the development of innovative tidal turbine system and coastal infrastructure, the popularization of tidal energy worldwide can be expected. Compare with other type of renewable energies, tidal energy has a lot of

Corresponding author. E-mail address: pli@et.aau.dk.

* Corresponding author. Tel.: +45-50326179

advantages, such as regularity, predictability and energy density. Its use is very effective as it relies on the similar technologies used in offshore wind turbines but it is still under development and requires more research. Due to the high density of water compared to air, the density of dynamics energy of water flow is much higher than air flow. Therefore, the tidal turbine is usually smaller than wind turbine and can work at a lower flow velocity.

Traditionally, the power system frequency control is normally provided by conventional synchronous generators. With the proportion of tidal power plant into power system increasing, the tidal power plant could not only reach the huge environmental and economic benefits, but also bring the new challenges of operating safety and stability in power system. Tidal power plant participates in frequency regulation and the coordination with stored energy of the power system will be an inexorable trend in the future.

This paper proposed a de-loading operating strategy, for enhance the capability of primary frequency control of tidal power plant, to trace the MPPT and primary frequency characteristics of DFIG. Also, improving the traditional pitch control system to adjust the mechanical power which is captured by DFIGs in the period of primary frequency control

2. Characteristic of Tidal Turbine Model and Generator Model

When the sea water passes the blades, the lift force, which is perpendicular to the flow direction, is produced and it makes the impeller to rotate. However, no matter what the case is, if the maximum flow speed is over 2m/s, it could be utilized by tidal turbines [3]. Simultaneously, the flow direction of sea water is regular, such as the flow direction is bidirectional which is caused by tide. The flow direction is unidirectional, which is caused by climate or density difference of sea water. The flow speed has small change in a short time and the changes will be regular in a long-time period.

In the tidal energy generation system, the variable-speed generation system is more proper and effective than the fixed-speed generation system because the variable-speed generation system is operated at the proper generator rotating speed when the tidal speed is changed. So, it has advantages of the high efficient tidal energy generation and the reduction of maintenance cost due to less stress to the tidal generation facilities. The tidal generation system operation according to the variable speed is controlled by using the MPPT (Maximum Power Point Tracking) control method. The tidal turbine considered in this paper applies a DFIG, using a back-to-back full-scale PWM voltage source converter connected to the grid. DFIG-based tidal turbines will offer several advantages, such as variable speed operation and four-quadrant active and reactive power capabilities. Indeed, considering the DFIG and the tidal current speed, the DFIG allows compensating these variations in acceptable proportions while guaranteeing a good quality of the produced energy.

A simplified hydrodynamic model is normally used when the electrical behavior of the tidal turbine is the main interest of the study. Considering the flexibility of the system, the inertia of main shaft and transmission system of gearbox should be calculated into impeller shaft. Also, the flexibility of main shaft and transmission system of gearbox should be equivalent to the output shaft of gearbox[4]. The equation is shown as following:

$$J_r' \frac{d\omega_r}{dt} = T_r - T_m - T_D \quad (1)$$

Where the $J_r' = J_r + n_1^2 J_1 + \dots + n_n^2 J_n$ is the sum of moment of inertia of impeller and the inertia of each transmission system which is calculated on the impeller shaft; $n_1, n_2, \dots, n_n, J_1, J_2, \dots, J_n$ is transmission ratio and moment of inertia in each level of transmission system; T_r is the hydraulic torque; T_m is the mechanical torque of gearbox output shaft; T_D is the damping torque; ω_r is the angular velocity of impeller.

Because of $C = P/\omega_r$, according to the theory of Betz, the relation between the tidal speed and hydraulic torque may be described by the following equation:

$$T_r = \frac{\rho v^3 S C_p(\lambda, \beta)}{2\omega_r} = \frac{1}{2} \rho S R C_T(\lambda, \beta) v^2 \quad (2)$$

Where, $C_T = C_p(\lambda, \beta)/\lambda$, $\lambda = \omega_r R/v$;

Fig.1 shows the relation curve of output power of impeller and rotational speed for different current speed. The maximum power curve of impeller can be presented as equation (3):

$$P_{\max} = k\omega_{opt}^3 \tag{3}$$

Where, ω_{opt}^3 is the optimal angular velocity of impeller, k is constant.

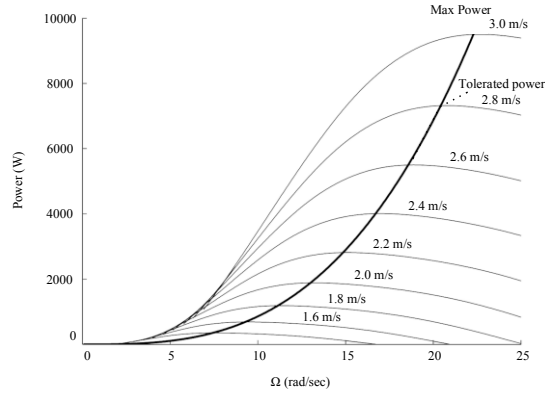

Fig. 1. The maximum power point tracking curve of DFIG

T_r can be linearized and calculated by Taylor expansion which is shown as following equation:

$$\Delta T_r = \frac{\partial T_r}{\partial \omega_r} \Delta \omega_r + \frac{\partial T_r}{\partial v} \Delta v + \frac{\partial T_r}{\partial \beta} \Delta \beta = \gamma \Delta \omega_r + \alpha \Delta v + \delta \Delta \beta \tag{4}$$

Where the coefficient of linearization is:

$$\gamma = \frac{1}{2} \rho S R_r^2 \left. \frac{\partial C_T}{\partial \lambda} \right|_{op} \tag{5}$$

$$\alpha = \frac{1}{2} \rho S v \left[2C_T \Big|_{op} - \lambda \left. \frac{\partial C_T}{\partial \lambda} \right|_{op} \right] \tag{6}$$

$$\delta = \frac{1}{2} \rho S R_r^2 \left. \frac{\partial C_T}{\partial \beta} \right|_{op} \tag{7}$$

Meanwhile,

$$T_D = c_1 + \frac{c_2}{\omega_r} + c_3 \omega_r \tag{8}$$

Where the ρ is fluid density; v is the fluid speed; S is the swept are of the blades; $C_p(\lambda, \beta)$ is energy utilization coefficient; $C_T(\lambda, \beta)$ is torque coefficient of impeller; λ is tip speed ratio (the ratio of tip linear speed and fluid speed); β is pitch angle; c_1, c_2, c_3 is constant.

At present, DFIG becomes the majority among the tidal generators in the tidal power plant and it uses the rotor side converter control to capture the maximum tidal energy and improve the efficiency of energy utilization. Fig.2 is the vector control diagram of the rotor side converter. The inner loop of system is current control loop. The reference values of current I_{rd}^*, I_{rq}^* are depended on the MPPT control and reactive power control of outer control, respectively [5]

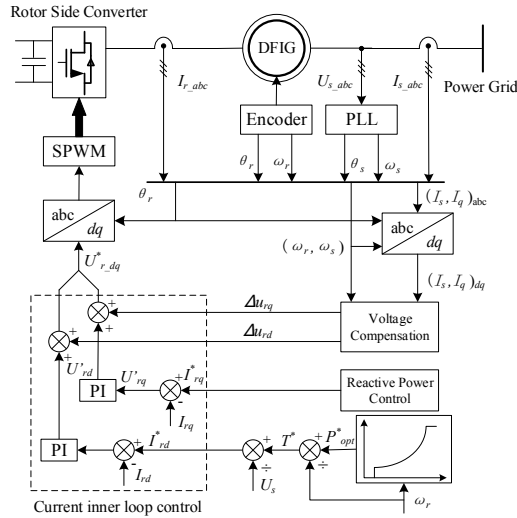

Fig. 2. Vector control diagram of the rotor side converter

The DFIG uses the converter control and pitch system control for MPPT when they working under the normal condition. The reference value of active power can be gotten as the following equation:

$$P_{opt}^* = \begin{cases} k_{opt} \omega_r^3, & \omega_0 < \omega_r < \omega_1 \\ \frac{(P_{max} - k_{opt} \omega_1^3)}{(\omega_{max} - \omega_1)} (\omega_r - \omega_{max}) + P_{max}, & \omega_1 < \omega_r < \omega_{max} \\ P_{max}, & \omega_r > \omega_{max} \end{cases} \quad (9)$$

Where k_{opt} is the proportional coefficient of the maximum power point curve; ω_0 is the initial angular speed; ω_1 is the angular speed in constant rotational speed area; ω_{max} is the limited value of ω_r ; P_{max} is the limited value of output active power.

3. The Frequency Dynamic Process and the De-loading Control

According to the different tide conditions, this strategy is to restore the reserve capability for the primary frequency control by increasing pitch angle. To make sure the reserve active power of DFIG for the primary frequency control, the output active power of DFIGs under the de-loading operation should be $(1-d)$. The de-loading capacity of DFIGs can be set as following equations:

$$d = -\frac{\Delta P_{de}}{P_0} \quad (10)$$

Where the ΔP_{de} is the de-loading power of DFIG.

For the single tidal turbine, if the de-loading power is set d , the de-loading power reference value can be shown as following equation:

$$P_{de} = (1-d)P_{opt} = 0.5\rho\pi R^2 C_{p-de} v^3 \quad (11)$$

$$P_{opt} = 0.5\rho\pi R^2 C_{p-max} v^3 \quad (12)$$

Where P_{de} , P_{opt} are the reference value of power and the reference power of maximum power tracing under de-loading operating condition, respectively; C_{p-de} is coefficient of the captured tidal energy in de-loading condition; C_{p-max} is the coefficient of the maximum captured tidal energy.

When the fluid speed v and fluid density ρ are unchanged, from the equation (11) and (12), the C_{p-de} can be calculated by following equation:

$$C_{p-de} = (1-d)C_{p-max} \quad (13)$$

From the equation (13), it shows that if the coefficient of the captured tidal energy decrease d , the de-loading

operation of tidal turbines can be realized.

Because of the drop range of frequency in power system should not over 0.5 Hz, tidal power plant should use reserve capacity to adjust the frequency change in security range of power system. Tidal turbines can control the de-loading level by improving the traditional pitch control to increase pitch angles and reduce the captured tidal energy. However, tidal turbines should still track the maximum power point after the de-loading operation.

When the system frequency changes suddenly, pitch control system could get frequency response by reducing pitch angle. The pitch control strategy is shown as fig.3.

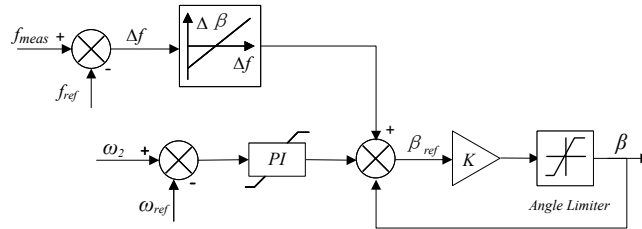

Fig.3 Frequency control with pitch control system

4. Simulations and Results

The small simplified simulation power system model is established by using Matlab/Simulink software, and it includes a 60 MW tidal power plant and an 80 MW thermal power plants as shown in Fig. 4. The power loads of Load 1 and Load 2 are both 40 MW.

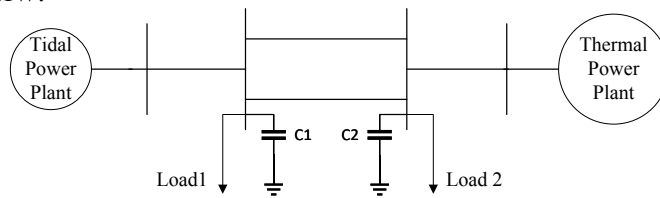

Fig.4. Simplified power system model

When the Load 2 has increased from 40MW to 55MW and the frequency of power system has decreased accordingly. When the tidal power plant participates into frequency control by using proposed control strategy. The frequency dip is reduced and the after-fault frequency is considerably increased. The simulation result is shown in Fig.5.

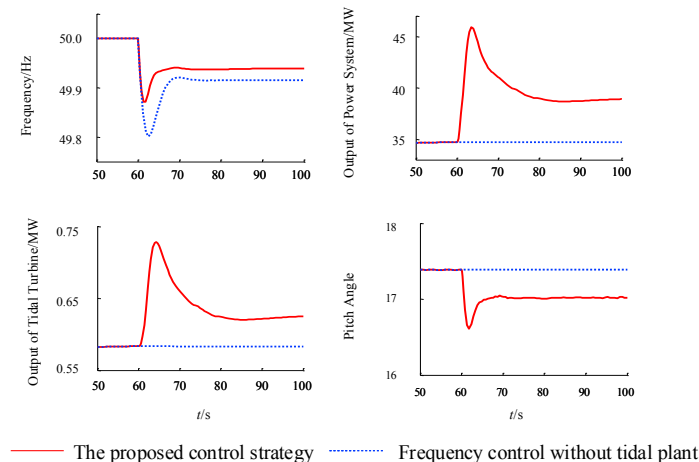

Fig.5. Frequency response curve of proposed control strategy

In fig.9, it compared with the system frequency f , active output power of power system P , output power of tidal turbine P_T and pitch angle β under frequency control without tidal plant and the proposed control strategy. From fig.9, the frequency dropped from 50 Hz to 47.9. After the tidal power plant uses the proposed control strategy, the ratio of frequency change obviously. The system frequency only dropped to 49.87 Hz and grew to 49.5Hz. In this frequency dynamic process, the pitch angle of tidal turbines increased to capture more kinetic energy. Due to the secondary frequency control has not been considered, the static frequency deviation of system has an obvious increase than the frequency control without tidal power plant. When the tidal turbine with DFIG operates under the proposed frequency control strategy, it could improve the features of frequency recovery in the process of primary frequency control. Simultaneously, the pitch angle of tidal turbines has rose again which benefits for tidal turbines to recover to the initial operating state.

4. Conclusion

This paper built a DFIG tidal turbine model to represent an aggregated tidal power plant model. A simulation test system with a tidal power plant and thermal plant is used as the test system. The frequency control strategy which is based on improved pitch control system to ensure the tidal power plant could participate into primary frequency control. Meanwhile, this is for improving the frequency stability of power systems. The proposed frequency control strategy could modify the pitch angle for the de-loading operation to reserve the capacity in various tidal speed.

References

- [1] Zhou, Qingwei, Yang Bai, Ye Li, Xiaoyong Wang, Haifeng Wang, Min Du, Song Zhang et al. "Reviews of development and utilization of tidal energy over Chinese offshore." In OCEANS 2016-Shanghai, pp. 1-5. IEEE, 2016.
- [2] Uihlein, Andreas, and Davide Magagna. "Wave and tidal current energy—a review of the current state of research beyond technology." *Renewable and Sustainable Energy Reviews* 58 (2016): 1070-1081.
- [3] Lagoun MS, Nadjem S, Benalia A, Benbouzid ME. Predictive power control of Doubly-fed induction generator for wave energy converters. In *Environment Friendly Energies and Applications (EFEA)*, 2012 2nd International Symposium on 2012 Jun 25 (pp. 312-317). IEEE.
- [4] Zhang D, Ma X, Si Y, Huang C, Huang B, Li W. Effect of doubly fed induction generator tidal current turbines on stability of a distribution grid under unbalanced voltage conditions. *Energies*. 2017 Feb 13;10(2):212.
- [5] Li P, Hu W, Hu R, Chen Z. The integrated control strategy for primary frequency control of DFIGs based on virtual inertia and pitch control. In *Innovative Smart Grid Technologies-Asia (ISGT-Asia)*, 2016 IEEE 2016 Nov 28 (pp. 430-435). IEEE.