



## Large Photovoltaic Power Plants Integration

### *A Review of Challenges and Solutions*

Mansouri, Nouha; Lashab, Abderezak; Séra, Dezso; Guerrero, Josep M.; Cherif, Adnen

*Published in:*  
Energies

*DOI (link to publication from Publisher):*  
[10.3390/en12193798](https://doi.org/10.3390/en12193798)

*Creative Commons License*  
CC BY 4.0

*Publication date:*  
2019

*Document Version*  
Publisher's PDF, also known as Version of record

[Link to publication from Aalborg University](#)

### *Citation for published version (APA):*

Mansouri, N., Lashab, A., Séra, D., Guerrero, J. M., & Cherif, A. (2019). Large Photovoltaic Power Plants Integration: A Review of Challenges and Solutions. *Energies*, 12(19), Article 3798.  
<https://doi.org/10.3390/en12193798>

### **General rights**

Copyright and moral rights for the publications made accessible in the public portal are retained by the authors and/or other copyright owners and it is a condition of accessing publications that users recognise and abide by the legal requirements associated with these rights.

- Users may download and print one copy of any publication from the public portal for the purpose of private study or research.
- You may not further distribute the material or use it for any profit-making activity or commercial gain
- You may freely distribute the URL identifying the publication in the public portal -

### **Take down policy**

If you believe that this document breaches copyright please contact us at [vbn@aub.aau.dk](mailto:vbn@aub.aau.dk) providing details, and we will remove access to the work immediately and investigate your claim.

Review

# Large Photovoltaic Power Plants Integration: A Review of Challenges and Solutions

Nouha Mansouri <sup>1</sup>, Abderezak Lashab <sup>2</sup>, Dezso Sera <sup>2</sup>, Josep M. Guerrero <sup>2,\*</sup> and Adnen Cherif <sup>3</sup>

<sup>1</sup> Department of Electrical Engineering, National School of Engineering Monastir, 5035 Monastir, Tunisia; nouha\_enim1@yahoo.fr

<sup>2</sup> Department of Energy Technology, Aalborg University, Pontoppidanstraede 111, DK-9220 Aalborg, Denmark; abl@et.aau.dk (A.L.); des@et.aau.dk (D.S.)

<sup>3</sup> Department of Electronic Systems, Analysis and Treatment of Electrical/ Energetic Systems Research Unit, Faculty of Sciences, Tunis 2092, Tunisia; adnan.cher@fst.rnu.tn

\* Correspondence: joz@et.aau.dk

Received: 19 August 2019; Accepted: 27 September 2019; Published: 8 October 2019

**Abstract:** Renewable energy systems (RESs), such as photovoltaic (PV) systems, are providing increasingly larger shares of power generation. PV systems are the fastest growing generation technology today with almost ~30% increase since 2015 reaching 509.3 GW<sub>p</sub> worldwide capacity by the end of 2018 and predicted to reach 1000 GW<sub>p</sub> by 2022. Due to the fluctuating and intermittent nature of PV systems, their large-scale integration into the grid poses momentous challenges. This paper provides a review of the technical challenges, such as frequency disturbances and voltage limit violation, related to the stability issues due to the large-scale and intensive PV system penetration into the power network. Possible solutions that mitigate the effect of large-scale PV system integration on the grid are also reviewed. Finally, power system stability when faults occur are outlined as well as their respective achievable solutions.

**Keywords:** angle stability; photovoltaic (PV); grid; power quality; large-scale power plant; voltage; frequency stability

---

## 1. Introduction

The worldwide interest in environmentally friendly power resources is exponentially increasing. Among several renewable energy systems (RESs), solar photovoltaic (PV) systems are one of the major types of distributed renewable energy (RE) generation that has unlimited supply capacity and is forecasted to become the largest source of RE by 2022. The solar PV capacity for network-connected application was estimated to be 509.3, 600, 700, 800, and 1000 GW<sub>p</sub> in 2018, 2019, 2020, 2021, and 2022, respectively [1]. The global PV capacity has been continually rising, and the yearly growth curve from 2015 to 2022 is illustrated in Figure 1.

Solar PV systems can be connected to either of two levels in a network and these systems can be categorized into three main categories according to their size: large, medium, and small. The large- or utility-scale PV power plants (LS-PVPP) are those typically generating above 100 MW<sub>p</sub>, so they can be connected to high or medium voltage. This category of PV energy is typically delivered in three phases and requires some transformers parallel to the power system. The second category, which is the medium-scale PV, generates from 1 to 100 MW<sub>p</sub> and is connected to the distribution level [2]. This category can particularly be found in all sizes of buildings such as government sites, malls, and residential areas. For residential areas, small-scale PV systems are used with a generation capacity that ranges from 1 up to 1000 kW<sub>p</sub>, where it is connected to low voltage. Due to the integration of solar PV systems, voltage increase, reverse power flow, and some other issues may

appear in the grid. As such, the connection of PV systems to the grid could introduce some additional problems and effects that must be attentively regarded and examined.

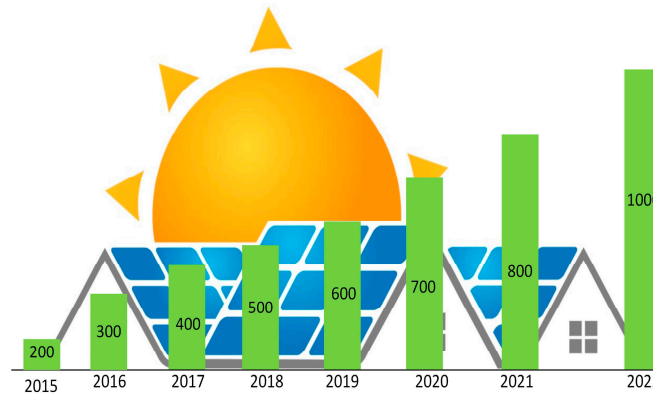

**Figure 1.** Evolution of the photovoltaic (PV) capacity (GW<sub>p</sub>) around the globe from 2015 to 2022 [1].

Some other challenges have been encountered due to the intense integration of LS-PVPPs into the power system. The variability of solar radiation is a significant issue that may lead to instability in the point-of-common-coupling (PCC), concerning the voltage and frequency responses. The control of LS-PVPP in power curtailment (PC) mode is becoming challenging due to the intermittent energy nature of the source. Reduced inertia is another challenging issue due to the absence of rotational machinery in LS-PVPPs, which is used in traditional power plants, thereby introducing instability in the grid. To this end, to ensure the reliability of PV system penetration in LS-PVPPs, the grid codes (GCs) must be analyzed as new GCs are needed from LS-PVPPs for better configurations as well as to improve the control stability.

Authors in [3–5] discussed some other issues related to the high level of integration of PV systems into the electrical power system, such as voltage drop and network losses. From the control and implementation points of view, the LS-PVPPs were studied [6].

The aim of this review was to present the key challenges of the integration of solar PV power generation into large-scale grids, and the various techniques adopted to enhance the power systems with intensive PV penetration stability.

Compared with the existing review papers available in the literature, this paper provides updated GCs for different countries, as well as the latest solutions to the problems faced due to the high integration of PV systems, especially for LS-PVPPs. This work is useful for academic researchers, industrial researchers, and engineers working in this field.

The rest of paper is organized as follows: Section 2 presents the main components of the grid-connected PV system. Section 3 elaborates upon a scope of recent GCs and regulations for grid-connected PV systems. In Section 4, the solar PV penetration impact on power system stability is presented. Section 5 elaborates upon the impact of PV penetration on voltage profiles. In Section 6, some fault ride-through techniques are presented. Some of the latest introduced maximum power point tracking (MPPT) techniques for PV systems are explored in Section 7. In Section 8, some new methods are presented, such as thermography infrared for detecting defective PV cells and panels. Finally, the conclusions drawn from the study and some recommendations for future research opinions are provided in Section 9.

## 2. Main Components Grid-Connected Photovoltaic System

The overall structure of a grid-connected PV source is illustrated in Figure 2. It consists of four main components: (i) a PV array that generates direct current (DC) power; (ii) a three-phase inverter, which is adopted to convert the DC to alternating current (AC) power; (iii) an LCL filter, which is used to suppress the switching harmonics generated by grid-connected inverters at the output

voltage and current; and (iv) a transformer that is used to step up the PV voltage while ensuring galvanic isolation.

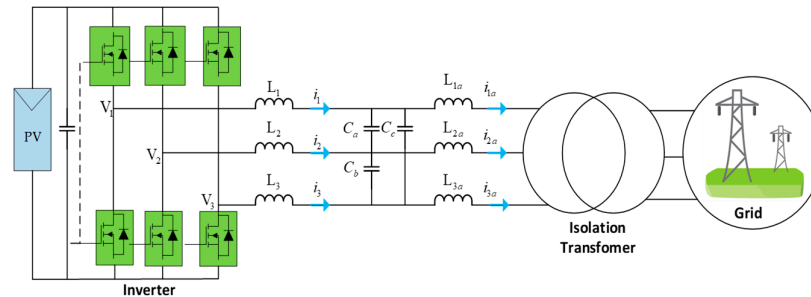

Figure 2. Main components of grid connected PV systems.

### 3. Overview of Grid Codes for Photovoltaic Integration

Large scale (LS) PV systems should meet certain grid connection criteria, commonly known as GCs, to guarantee the safe and reliable supply of electricity with embedded PV power plants. For this purpose, several distinct studies of modern international GC requirements regarding the integration of PVPPs in power system for several countries have been explored. Germany developed the first technical GC specifically for PVPPs interconnected to medium- (MV) and high-voltage (HV) networks in 2008. These specifications were analyzed in some studies [6,7]. The focus of these requirements on the response of the PVPP is during failures. After the German's GC, some other sites created their own GCs, including South Africa, China, Japan, Italy, Spain, Australia, Malaysia, and Romania. An overview of some challenges of LS PV integration into LV and MV networks was published by Shah et al. [8]. Obi and Bass [9] analyzed the technical issues with and the trends in PV integration.

This section presents a comparison of several requirements in Germany, Spain, Italy, Australia, China, Malaysia, Japan, Romania, and South Africa for the connection of PVPPs to the HV network, which was used in [10]. The comparison is established based on particular criteria such as nominal frequency, frequency constraints, low-voltage ride through (LVRT), high-voltage ride through (HVRT), and power factor (PF) range at the PCC. These are listed in Table 1.

The GCs presented in this study have some similarities but also significant differences, as the specifications for each grid are tailored to the electrical network features. Table 1 shows that the most extreme frequency boundaries from the nominal value are around  $-3.5$  and  $+2.5$  Hz. Germany also has a broad variety of frequency boundaries for standard operation.

Depending on the operator requirements and the reliability of the network, the parameters of LVRT specifications stated in various GCs may differ from country to country. In Germany and Malaysia, a delay in connection for the PVPP equal to 0.15 s is imposed [10] when the voltage is moving to zero of the rated voltage at the PCC. This case is the so-called zero VRT. If 90% [10] of the pre-distributed voltage value could be recovered at the connection point of 1.5 s, the PVPP will remain in normal operation without tripping. In Japan, prerequisites state that PVPPs should withstand a voltage drop of 20% of the rated value for 1 s and then increase to 80% [10] at the PCC. The GC in Italy requires the PVPPs to support network failures with voltage drop (to 0 for 0.2 s) [10], followed by voltage restoration to 90% [10] of its rated value within 1 s [10] after the voltage drop. The Romanian GC, however, requires the PVPPs to handle grid faults for 0.62 s [10] in case of voltage increase by 15% [10]. In Spain, regulations state that PVPPs must to withstand a voltage drop of 20% of the rated value for 0.5 s and then increase to 85% [10] in the next 0.5 s [10] at the PCC.

The Australian GC has the most rigid LVRT requirement, which requires the PVPPs to handle a decrease to 0 voltage at the PCC and increase back to 80% simultaneously [10].

**Table 1.** Required nominal frequency, frequency limits, low-voltage ride through (LVRT), high-voltage ride through (HVRT), and power factor (PF) for point-of-common-coupling (PCC) grid codes (GCs) in some countries. ND: not define.

Country	GCs	Nominal Frequency (Hz)	Frequency Grid ( $f_B$ ) Limits (Hz)	Maximum Duration	LVRT				HVRT		PF at Point of Connection	
					Fault Time		After Fault		During Voltage Swell		Leading Power Factor-Capacitive	Lagging Power Factor-Inductive
					V1 (%)	t2 (s)	V2 (%)	t3 (s)	V (%)	t (s)		
Germany		50	$f_B > 51.5$ $47.5 < f_B < 51.5$ $f_B < 47.5$	Instant disconnection No trip (continuous) Immediate disconnection	0	0.15	90	1.5	120	0.1	0.95	0.95
Italy		50	ND	ND	0	0.2	85	1.5	125	0.1	0.95	0.95
Spain		50	$f_B > 51.5$ $47.5 < f_B < 51.5$ $48 < f_B < 47.5$ $f_B < 47.5$	Immediate disconnection Continuous operation 3 s Immediate disconnection	20	0.5	80	1.0	130	0.25	0.85	0.85
Australia		50	$f_B > 52$ $47.5 < f_B < 52$ $f_B < 47.5$	2 s Continuous operation 2 s	0	0.45	80	0.45	130	0.06	0.9	0.95
Romania		50	$f_B > 52$ $47.5 < f_B < 52$ $f_B < 47.5$	Immediate disconnection No trip (continuous) Immediate disconnection	15	0.625	90	3.0	ND	ND	ND	ND
Malaysia		50	$f_B > 52$ $47 < f_B < 52$ $f_B < 47$	Immediate disconnection Continuous operation Immediate disconnection	0	0.15	90	1.5	120	Continuous	0.9	0.85
Japan	Eastern	50	$f_B > 51.5$ $47.5 < f_B < 51.5$ $f_B < 47.5$	Immediate disconnection Continuous operation Immediate disconnection	20	1.0	80	1.2	NS	NS	ND	ND
	Western	60	$f_B > 61.8$ $58 < f_B < 61.8$ $f_B < 58$	Immediate disconnection Continuous operation Immediate disconnection								
South Africa		50	$f_B > 52$ $51 < f_B < 52$ $49 < f_B < 51$ $48 < f_B < 49$ $47 < f_B < 48$ $f_B < 47$	4 s 60 s Continuous operation 60 s 10 s 0.2 s	0	0.15	85	2.0	120	0.15	0.95	0.95

In the case of HVRT, several GCs described in this section indicate that in Spain and Australia, regulations have strict HVRTs, requiring the PVPPs to handle voltage swells with a voltage rise of up to 130% [10] of the nominal voltage at the PCC [10]. In Germany, the solar PV farms should ensure a transfer of the reactive power (RP) at the PCC's nominal active power (AP) with a PF ranging from 0.95 inductive to 0.9 capacitive [10]. The Southern Africa and Italian GC impose RP control regulation similar to the German regulation in different scenarios of operation, and the PF at the PCC varies between 0.95 capacitive and 0.95 inductive [10].

Smart PV systems capable of performing reliable grid support tasks have the potential to become part of the solutions for future power generation. PVPPs need to provide more ancillary services, such as voltage and frequency regulation, spinning reserve, or even the possibility of black starting, for future GC compliance.

#### 4. Photovoltaic Penetration Impact on Power System Stability

##### 4.1. Frequency Stability

Variations in frequency in the grid may occur due to the increased penetration of PV systems [11]. Research attempts were dedicated to high PV penetration impacts [12]. Among those impacts are the system angle and frequency stability during reduced system inertia with high PV inputs. PV generation systems have very low inertia; thus, integrating large PV plants as a substitute for the conventional generators decreases the inertia of the bulk power system. Consequently, the system would not be able to manage the frequency fluctuations caused by frequent load demand changes. Although shown that the frequency support worsens due to the inclusion of high-level renewable generation technologies [13], by extra control the frequency support can be improved. In [14], the effects of LS solar PV generation on the frequency stability of the power system and the capability of the frequency response of power systems were explored. The beneficial impact of PV power plants is their ability to promote system frequency recovery after significant disturbances during the initial seconds.

As illustrated in Figure 3, the system frequency in normal conditions is near to its nominal frequency (50 Hz). However, when an event occurs, the system begins to deviate. This imbalance must be adjusted using frequency control loops. To improve the system stability, these controllers are employed and they cover two times frames: the primary frequency response (PFR) and the secondary frequency response (SFR).

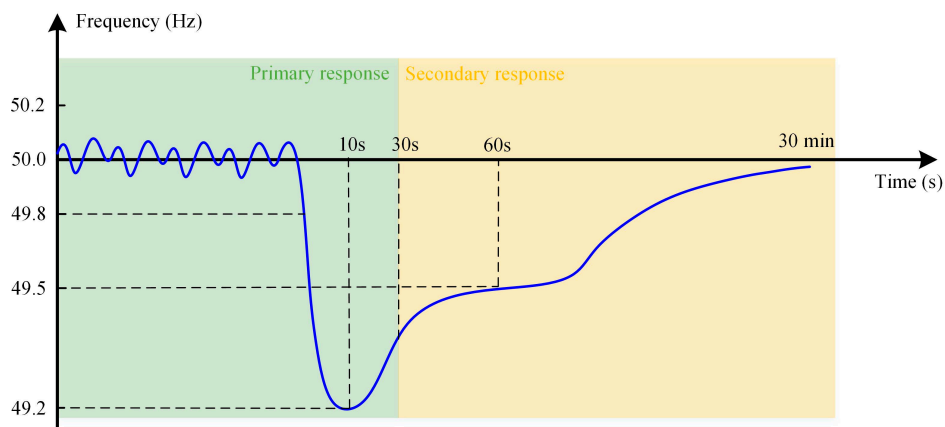

Figure 3. Time frames involved in the system frequency response [14].

A large difference in new technology appears between the PV array, inverter, and the traditional power plants. Due to the absence of a rotating machine and the energy variability, several issues with frequency stability occur in the electrical system [15]. In the case of the Australian PV integration

network, issues in frequency regulation arise due to the low inertia and PV generation variation [16]. Abdrahem et al. [17] investigated the impact of a large PV plant integration on the frequency stability of power systems under four LSPPVs. In this method, they tested 200 MW<sub>p</sub> PV plants that were connected to a 230 kV utility transmission grid through two converters and a transformer. The first stage converts from continuous voltage to continuous voltage using a boost converter, and the second stage converts continuous to alternating voltage and to the transformer stage. The third stage consists of four transformers, where each one is 2 kV. A second transformation stage is composed of an 11 kV/230 kV transformer connected directly to the utility. The 200 MW<sub>p</sub> PV is divided into four 50 MW<sub>p</sub> generators connected to two areas, each area includes four synchronous 700 MW<sub>p</sub> generators. This example shows that the frequency stability is not influenced when considering any decrease in standard generators with increased PV penetration. However, reference [18] reported that the increase in PV leads to frequency instability. Some studies were reviewed [15] about the impact of the decreased inertia in the electrical system with increasing PV penetration. The greatest challenge for LS-PVPP is finding a solution to the lack of inertia for PFR and SFR control. When working the LS-PVPPs at the maximum power point (MPP), they do not have the power reserve to control a decrease in frequency.

#### 4.2. Angle Stability

Angle stability is adversely affected by increasing PV penetration into the power system. This contributes to reducing the system inertia and increasing the generator reactance; thus, the generator transient stability may be negatively affected. In particular, the effect on transient stability may become more severe if significant quantities of PV units are disconnected simultaneously during voltage decrease [19]. Mahalakshmi et al. [20] stated that the system inertia is lowered after the synchronous generator is substituted by PV sources, and when the PV penetration is higher, the generator rotor angle oscillates more and causes less system stability. The increasing oscillation may result in a loss of stability due to the lower inertia in the power system with a higher PV penetration rate, which may be a reason for future issues with angle stabilization. PV was shown to have both negative and positive impacts on the performance of transient stability depending on the place of the fault and the length of the fault [21]. Tamimi et al. [22] indicated that distributed PV generators could significantly improve transient stability compared with centralized PV generators. More recent research [23] proposed a probabilistic technique for small-signal stability analysis of power systems with PV integration. Low solar irradiance directs the real part of the critical value to the right side of the complex plane and leads to a high proportion of instability on the system with high gains of the current regulator and the impedance controller. A systematic methodology [24] was proposed to explore the stability of the rotor angle when the PV integration is high and maintaining steady-state system parameters with solar PV integration. These parameters include AP, RP, and the difference in the maximum angle of the rotor. The results of the study showed that stability improved through the integration of PV generation, except in remote fault situations where power system stabilizer (PSS) generators are substituted by PV generation. Transient stability has declined due to increased PV penetration when a fault occurs at critical points; however, it has been improved when a fault occurs at a less critical point. Consequently, fault proximity to PV generation is a critical factor affecting transient stability.

### 5. Photovoltaic Penetration Impact on Voltage Profiles

#### 5.1. Voltage Stability

Large-scale PV integration may produce voltage instability in a system [25]. The research [22] showed that regardless of the volume of PV integration into the system, the network experiences both beneficial and detrimental effects in terms of steady-state stability. Eftekharijad et al. [26] analyzed the effect of PV penetration in the Ontario, Canada area with distributed PV systems. The analysis considered different penetration levels of up to 2000 MW<sub>p</sub>. The effect of variable irradiation on

voltage fluctuations was analyzed considering different levels of penetration of PV energy (0% to 16%) [27]. The switching of synchronous generators by PV systems produces some effects on the magnitude of the voltage and the severity of the harmful impact rises with increasing PV integration. To avoid voltage fluctuations, a constant PF controller or an automatic voltage controller (AVC) using the PV converter itself was adopted, as described in Figure 4.

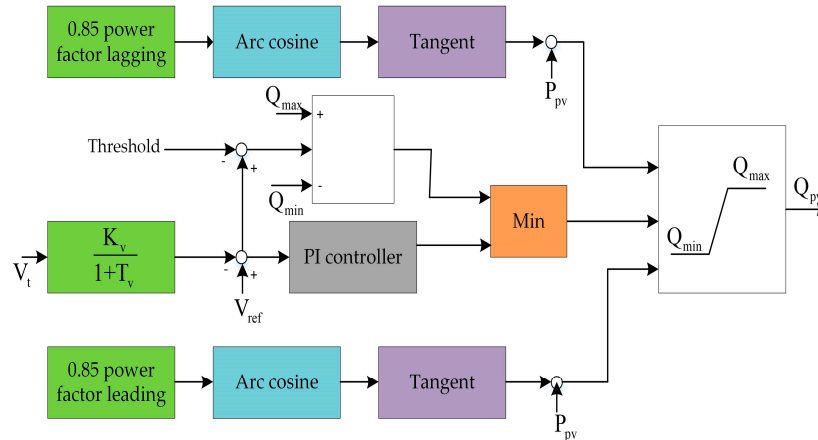

**Figure 4.** Automatic voltage control from a PV generator [27].

Figure 4 shows the proportional integrator (PI) controller that is included in this AVC scheme in conjunction with a PV inverter. The error signal driving the PI controller corresponds to the difference between the reference terminal voltage,  $V_{ref}$ , and the measured terminal voltage,  $V_t$ . The implemented AVC of the PV generator operates in a range from 0.85 lagging to 0.85 leading. Due to the fault of the short circuit (SC), the RP amount required by the controller is achieved at the peak. After SC, an over-voltage phenomenon occurs; thus, an over-voltage protection loop is introduced when the voltage is reduced under a boundary value [28]; thus, the RP demand decreases to the maximum value of  $Q_{min}$ .

The PVPPs implemented in different areas of a network were investigated [29] and the authors proved that as the generated power of the PV increases from 0.2 to 10 MW<sub>p</sub>, the obtained form of the voltage is a parabolic trend. Therefore, to solve the problem of voltage fluctuation in the case of massive PV integration, constant PF control and automatic inverter voltage control are applied in this method. Zhang et al. [30] proposed the transient overvoltage (TO) PV behavior at the PCC. Through results on this work, the authors proved that TO events depend on the size of a PV system, the placement of supervisory voltage control (SVC), and the lack of synchronous generators in the vicinity of the PV system. This work proved that the TO issue worsens as the amount of PV in the system and the distance of the PCC from the network increase. A synchronous generator can decrease the transient overvoltage rate; SVC can worsen this issue.

## 5.2. Active Power Curtailment

The high level of integration of solar PV in the network leads to some problems regarding overvoltage and overload [31,32]. Luthander et al. [33] investigated a solution for PV PC and placement of decentralized energy storage (ES) to control voltage and current. The maximum allowed feed-in power for each prosumer is defined in this method to determinate the PC needed for PV systems or decentralized ES. Thus, a combination of ES and PC can be adopted. Other voltage control techniques are presented in [34]. The result shows that with PV, AP output curtailment methods and local RP control are possible to decrease the need for voltage-driven grid reinforcement. Tonkoski et al. [35] detailed that PV inverters provide voltage support based on AP curtailment (AP voltage drop control). At the extremity of the feeder, the voltage tends to be the higher when the generation is high and consumption is low. These results are found at the extremity of the feeder during high

curtailment of the AP output of the inverters, whereas low or even no curtailment occur for the inverters located closer to the transformer. To mitigate this imbalance in AP curtailment-based voltage support schemes, a secondary voltage controller can be implemented. An inverter's apparent power should be increased to provide RP without losing a part of AP.

In [36], using the MPPT control lead to limit the generated power from PV, a smoothing effect was proposed to limit the PV ramp-ups to 1% of the PV rated capacity per minute. In this study, the limitation of PV production was not addressed when radiation decreases. It has been concluded that the output fluctuation declined by 28%. A case example of an active PC is shown in Figure 5, where the power could be curtailed either through MPPT interference or ES functionality as stated earlier.

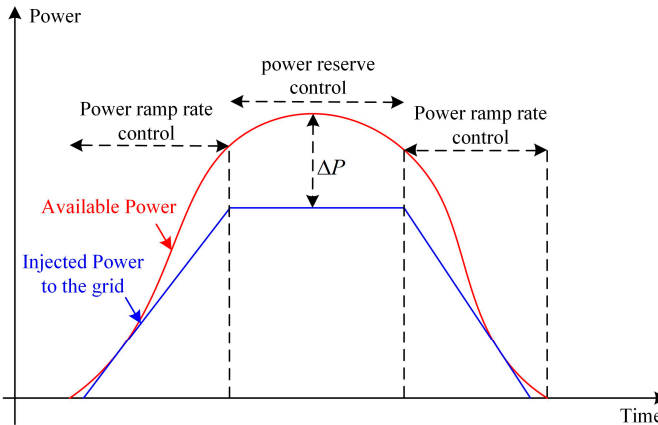

Figure 5. Active power (AP) curtailment.

### 5.3. Reactive Power Control

Due to the massive integration of PV sources, the disconnection of all PV systems with the occurrence of grid faults, like voltage flicker, power outages, and other power quality issues, may appear. For avoiding these problems, some changes in GC for LV or MV applications are recommended to ensure the reliable continuity of PV systems power and guarantee to generate ancillary services, such as RP support and LVRT capability. The German GC needs RP injection under perturbation [37]. Different methods were addressed [38] using RP control techniques on three-phase four-wire PV systems. The *abc*-frame was applied. Each applied method was verified under LV operation conditions via a computer simulation to choose the proper strategy, which ensured maximum AP injection during the LVRT with a lower power rating for the inverter.

Zhou et al. [39] proposed an RP control strategy for PVPPs based on a stationary reference frame and a positive sequence voltage detector. This proposed method showed that changing reactive and AP leads to voltage stability at the PCC. Another method involves ignoring any temperature and irradiance variation, so only disturbance in the grid is considered. This method was proposed by Minambres-Marcos et al. [40] and used PF control to regulate the voltage. Although the solar generation and the control of RP are variable, PV plants injecting or absorbing RP can help regulate voltage at the PCC [41].

The RP control method is performed in the inner loop, as shown in Figure 6. The AP of PV ( $P^{PV}$ ) is generated by the PV system daily. Online control of the AP generated is communicated to the data center, considering the operating PT of all PVs is close to unity. This value is communicated hourly to the utility control center through a communication channel. Then, the forecasted PV power used to distribute AP flow and to regulate the system voltage is included by the data center. The forecasted power is subtracted by the value tracked by the MPPT to determinate the variation in the AP output of a PV system. When the generated AP ( $P^{PV}$ ) is less than the expected value ( $P^{PV}$ ) of the utility's voltage regulating system, this is indicated by a positive  $\delta p_{pv}$ . Thus, the quantity VAR of  $\delta q_{pv}$  must be injected by the PV system. Otherwise, if  $\delta p_{pv} = 0$ , an absorbed quantity of  $\delta p_{pv}$  is introduced by a

negative  $\delta q_{pv}$ ; the PV is not obliged to provide or absorb RP. Then, in the case of an equal  $P^{ref}$  and  $P^{pv}$ , a combination of reference RP  $Q_{ref}$  with a reference AP  $P_{ref}$  is:

$$\delta p^{pv} = \delta p_f^{pv} - p^{pv} \tag{1}$$

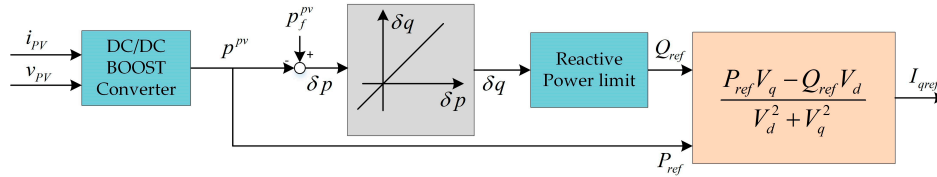

Figure 6. Reactive power (RP) control scheme [37].

The difference between the measured DC input voltage  $V_{dc_{mes}}$  and the reference value  $V_{dc_{ref}}$  refers to  $I_{d_{ref}}$ . The  $q$ -component current  $I_{q_{ref}}$  is demonstrated by:

$$I_{q_{ref}} = \frac{P_{ref} V_q - Q_{ref} V_d}{V_d^2 + V_q^2} \tag{2}$$

Xiao et al. [42] proposed online supervisory voltage control without considering solar generation variation. The main goal of this method, which includes an algorithm for RP allocation and online voltage tracking, is to ensure the compensation of voltage fluctuation caused by PV AP variations and improve the network voltage profile.

### 6. Fault Ride Through

Fault ride through (FRT) capability is a grid interconnection requirement for solar PV systems to avoid technical issues such as cascading frequency drop. In [43], the implementation of fundamental measures to facilitate PCS performance improvement in terms of FRT were studied and proposed. In the case of a voltage drop, PV converters are not obliged to break down. Knowing that the operation of the PV system is disconnected, the recovery of the output of the PV system is necessary to quickly prevent any variation in the frequency of the power system. In other studies [44,45], considering LS PV systems in MV networks, control methods are dedicated to ameliorating the FRT capability in the grid. The detailed fault analyses highlighted the robustness of the controller in LS PV networks. A non-linear feedback controller (LFC) has been suggested [46] to guarantee the actual rate and maintaining the FRT function of solar PV. The proposed control strategy is illustrated in Figure 7.

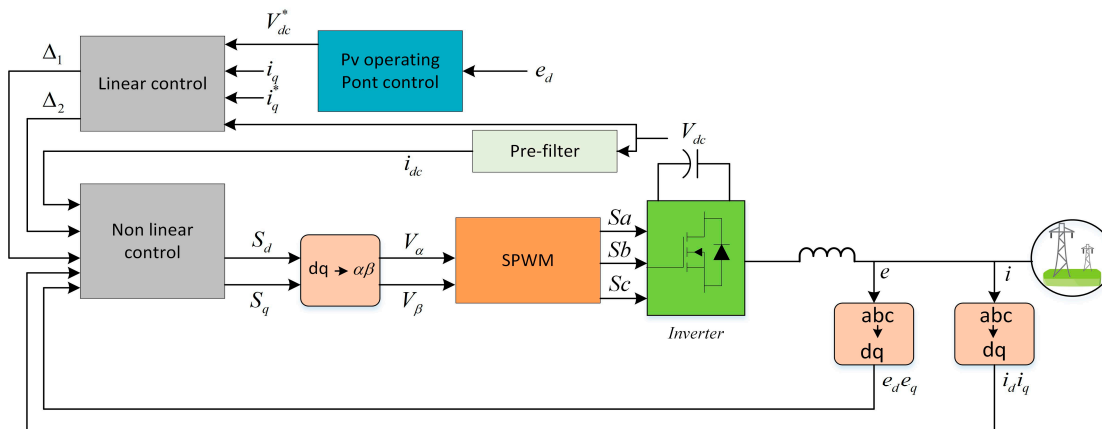

Figure 7. Control strategy scheme [46].

The inverter model used in this control in Figure 7 is written as follows:

$$\begin{aligned} L \frac{di_d}{dt} &= e_d + \omega L i_q - R i_d - V_{dc} S_d \\ L \frac{di_q}{dt} &= e_q - \omega L i_d - R i_q - V_{dc} S_q \\ c \frac{dV_c}{dt} &= \frac{3}{2} (i_q S_q + i_d S_d) - i_{dc} \end{aligned} \quad (3)$$

where  $i_d$ ,  $i_q$ ,  $e_d$ , and  $e_q$  refer to the currents and voltages of the alternative side in the  $d$ - $q$  rotating reference frame,  $s_d$  and  $s_q$  correspond to control signals,  $v_{dc}$  is the DC voltage,  $R$  corresponds to the resistance and  $L$  refers to inductance between the HV terminals of the network, and  $c$  is the capacitance in the DC voltage. To improve the FRT capability of a PV system via an LFC, which is able to be further studied as this controller can deliver a predictable system response. A coordinated control based on a LS PV system was addressed [47] to support the FRT function while maintaining the DC voltage of the inverter. In [48], the optimization of an error-based quadratic cost function that facilitates consumption monitoring relied on a predictive direct power control (PDPC) model for an inverter connected to the PV system with the grid. Although this model is known for good performance for AP and RP control, the computational burden is high. This applied model that is adopted in standard conditions and the power components are not considered during grid disturbances. The regulation of DC voltage is not restored in this control. In [49,50], considering the discretization of the power model, a simplified PDPC method was widely adopted under balanced network voltage. The expression of the predicted model of these control strategies based on the power model is adopted in balanced network voltages, knowing that it cannot be applied with unknown anomalies in the network because all power components are not considered in this model. These control methods do not integrate the necessary power model in their application. Another work [51] proposed a quiet predictive control system related to a solar PV system connected to a network with FRT capability, which was verified under abnormal conditions. This proposed controller maintains a constant DC voltage under grid disturbance while curtailing the AP. The injection RP are also prevented to reinforce the grid operation.

## 7. Maximum Power Point Tracking Techniques

The maximum power generated by the PV system essentially depends on the variations in temperature and solar radiation [52,53]. Thus, MPPT is required. Several techniques have been reported in the literatures, where the most often adopted are open-circuit voltage technology (OCVT) [54], perturbation and observation (P&O) [55], and incremental conductance (IC) [56]. The latter two methods are similar in the perturbation implementation on the control variable; both methods are applicable to any type of PV module where information about the PV modules is not required [57]. Multiple peaks appear in the power-voltage ( $P$ - $V$ ) curves in the case of partial shading [58]. The later mentioned methods reach the local MPP but they fail to analyze all the peaks to reach the highest MPP [59].

Presently, the bio-inspired algorithms are considered the most efficient, considering their robust features for addressing nonlinear and stochastic optimization problems, such as genetic algorithms [60], particle swarm optimization (PSO) [61], artificial bee colony (ABC) [62] and glowworm swarm optimization (GSO) [63], where they have been applied to MPPT application to address the partial shading issue. In [62], the ABC method demonstrates several characteristics like simplicity, robustness, fewer parameters of control, and independent convergence time on the initial conditions. All these parameters allow its performance to be superior to those of other bio-inspired methods in MPPT applications. Thus, the MPPT strategy using ABC provide a classical and robust MPPT scheme that proves the performance of a method by comparing it with the PSO method. In [64], an algorithm was proposed for the partial shading that uses a combination of two methods in the same application.

The first phase adopts PSO for MPPT and the second phase uses the conventional method P&O. Thus, the combination of these two traditional methods, P&O and swarm intelligence, is more efficient and can rapidly converge to the MPPT compared with the application of each method independently. Another MPPT method was proposed [65] with GSO for PV in a PV/T system under non-uniform solar irradiation and temperature distribution. This technique adopts the P&O algorithm as well as the OCVT technique. The proposed method allows for quick tracking of the actual MPP under different conditions, such as gradient temperature distribution, fast and variable solar radiation, and variable partial shading.

## 8. Investigating Impacts on Photovoltaic Cells and Panels

To guarantee the reliability of energy production from solar panels, firstly, the constraints that can be sustained throughout their lifetime, as well as the internal factors affecting solar energy should be examined, such as manufacturing and meteorological conditions. All these factors affect the degradation of the panels. Thus, to avoid these problems, diagnostic techniques have been proposed to facilitate the detection of defective modules and PV cells. Nondestructive testing (NDT) techniques are the most successful. Some of these best known methods are the liquid penetrant, ultrasonic testing, infrared thermography, eddy current mapping, and photoacoustic methods. Each of these methods has advantages and limitations. The choice of the method depends on factors such as the geometry and material properties of the inspected structure, as well as the type of detected defects [66]. An analysis was conducted with an infrared thermography (IT) camera to determine how the PV modules and cells are thermally affected during operation [67]. For this, a test was conducted on a standard monocrystalline silicon PV module, distributed along three strings of equivalent cells using bypass diodes, under different shading fractions. IT application is not applicable everywhere as it is time-consuming for large sites, labor-intensive, and applicable only to selected areas. Thus, a combination of aerial inspection techniques by unmanned aerial vehicles (UAVs) [68–70] were developed for the rapid detection of defects in the entire installation. In [71], this combined method was applied to a 1 MW<sub>p</sub> multicrystalline PV plant located in Brazil that had been damaged by a tsunami. In [72], an IT on an UAV was adopted to capture infrared images of PV power plants and showed that the thermal dissipation of the module can be estimated from the temperatures extracted from infrared imagery.

## 9. Conclusion and Future Trends

An updated review mainly focused on the effect of the penetration of PV power was presented in this paper. High PV penetration can have adverse effects on the utility grid, including frequency disturbances and voltage limit violation at the PCC. Some of the control methods used for PV integration in distribution networks were presented. We provided an overview of GC requirements implemented in some different locations around in the world to meet PVPP integration requirements. As the grid is affected by high PV penetration, methods that were designed to deal with it, such as active PC, were discussed together with other techniques based on RP injection.

Future research is required on low-inertia systems in the case of high levels of PV penetration in utility networks, including:

- Considering an ES system and a super capacitor in future research to improve grid stability and simultaneously mitigate short-term power fluctuations.
- Developing intelligent, robust, and advanced strategies, and fast communication technologies to improve the inertia and frequency regulation of the system.

**Author Contributions:** N.M. wrote the main part of the manuscript, A.L. helped in writing and revising the manuscript. D.S. contributed to setting the paper's main structure as well as its revision. J.M.G. helped in setting the paper's main structure. A.C. contributed to revising the manuscript.

**Funding:** This research received no external funding.

**Conflicts of Interest:** The authors declare no conflict of interest.

## Abbreviations

RES	renewable energy system
RE	renewable energy
MPPT	maximum power point tracking
LS-PVPP	large-scale photovoltaic power plant
PV	photovoltaic
PI	proportional integral
GC	grid codes
PF	power factor
LV/HV	low voltage/high voltage
MV	medium voltage
PRF	primary frequency response
SFR	secondary frequency response
PVPP	photovoltaic power plants
ES	energy storage
RP	reactive power
AP	active power
PC	power curtailment
LFC	linear feedback controller
AVC	automatic voltage control
LVRT	low-voltage ride through
HVRT	high-voltage ride through
PCC	point common coupling
PSS	power system stabilizer
SVC	supervisory voltage control
MPC	model predictive control
PDPC	direct power control
FRT	fault ride through
PSO	particle swarm optimization
ABC	artificial bee colony
GSO	glowworm swarm optimization
UAV	unmanned aerial vehicle
IT	infrared thermography
MW <sub>p</sub>	megawatt
kW <sub>p</sub>	kilowatt
NDT	non-destructive testing
OCVT	open-circuit voltage technology
P&O	perturbation and observation

## References

1. Michael, S. *Solar Market Outlook for 2018–2022*; Solar Power Europe: Brussels, Belgium, 2018; pp. 1–81.
2. Karimi, M.; Mokhlis, H.; Naidu, K.; Uddin, S.; Bakar, A.H.A. Photovoltaic penetration issues and impacts in distribution network—A review. *Renew. Sustain. Energy Rev.* **2016**, *53*, 594–605, doi:10.1016/j.rser.2015.08.042.
3. Widén, J.; Wäckelgård, E.; Paatero, J.; Lund, P. Impacts of distributed photovoltaic on network voltages: Stochastic simulations of three Swedish low-voltage distribution grids. *Electr. Power Syst. Res.* **2010**, *80*, 1562–1571, doi:10.1016/j.epsr.2010.07.007.
4. Gallo, D.; Langella, R.; Testa, A.; Hernandez, J.C.; Papič, I.; Blažič, B.; Meyer, J. Case studies on large PV plants: Harmonic distortion, unbalance and their effects. In Proceedings of the IEEE Power and Energy Society General Meeting, Vancouver, BC, Canada, 21–25 July 2013; doi:10.1109/PESMG.2013.6672271.
5. Marinopoulos, A.; Papandrea, F.; Reza, M.; Norrga, S.; Spertino, F.; Napoli, R. Grid integration aspects of large solar PV installations: LVRT capability and reactive power/voltage support requirements. In

- Proceedings of the 2011 IEEE PES Trondheim PowerTech: The Power of Technology for a Sustainable Society, Trondheim, Norway, 19–23 June 2011; doi:10.1109/PTC.2011.6019324.
6. Morjaria, M.; Anichkov, D.; Chadliev, V.; Soni, S. A grid-friendly plant: The role of utility-scale photovoltaic plants in grid stability and reliability. *IEEE Power Energy Mag.* **2014**, *12*, 87–95, doi:10.1109/MPE.2014.2302221.
  7. Mirhosseini, M.; Agelidis, V.G. Performance of large-scale grid-connected photovoltaic system under various fault conditions. In Proceedings of the IEEE International Conference on Industrial Technology, Cape Town, South Africa, 25–28 February 2013; doi:10.1109/ICIT.2013.6505944.
  8. Shah, R.; Mithulanathan, N.; Bansal, R.C.; Ramachandaramurthy, V.K. A review of key power system stability challenges for large-scale PV integration. *Renew. Sustain. Energy Rev.* **2015**, *41*, 1423–1436, doi:10.1016/j.rser.2014.09.027.
  9. Obi, M.; Bass, R. Trends and challenges of grid-connected photovoltaic systems—A review. *Renew. Sustain. Energy Rev.* **2016**, *58*, 1082–1094, doi:10.1016/j.rser.2015.12.289.
  10. Cabrera-Tobar, A.; Bullich-Massagué, E.; Aragüés-Peñalba, M.; Gomis-Bellmunt, O. Review of advanced grid requirements for the integration of large scale photovoltaic power plants in the transmission system. *Renew. Sustain. Energy Rev.* **2016**, *62*, 971–987, doi:10.1016/j.rser.2016.05.044.
  11. Lashab, A.; Sera, D.; Martins, J.; Guerrero, J.M. Multilevel DC-link converter-based photovoltaic system with integrated energy storage. In Proceedings of the 2018 5th International Symposium on Environment-Friendly Energies and Applications (EFEA), Rome, Italy, 24–26 September 2018; doi:10.1109/EFEA.2018.8617110.
  12. Bevrani, H.; Ghosh, A.; Ledwich, G. Renewable energy sources and frequency regulation: Survey and new perspectives. *IET Renew. Power Gener.* **2010**, *4*, 438–457, doi:10.1049/iet-rpg.2009.0049.
  13. Dehghanpour, K.; Afsharnia, S. Electrical demand side contribution to frequency control in power systems: A review on technical aspects. *Renew. Sustain. Energy Rev.* **2015**, *41*, 1267–1276, doi:10.1016/j.rser.2014.09.015.
  14. Rahmann, C.; Castillo, A. Fast frequency response capability of photovoltaic power plants: The necessity of new grid requirements and definitions. *Energies* **2014**, *7*, 6306–6322, doi:10.3390/en7106306.
  15. Seneviratne, C.; Ozansoy, C. Frequency response due to a large generator loss with the increasing penetration of wind/PV generation—A literature review. *Renew. Sustain. Energy Rev.* **2016**, *57*, 659–668.
  16. Yan, R.; Saha, T.K.; Modi, N.; Masood, N.A.; Mosadeghy, M. The combined effects of high penetration of wind and PV on power system frequency response. *Appl. Energy* **2015**, *145*, 320–330, doi:10.1016/j.apenergy.2015.02.044.
  17. Abdrahman, A.; Venayagamoorthy, G.K.; Corzine, K.A. Frequency stability and control of a power system with large PV plants using PMU information. In Proceedings of the 45th North American Power Symposium, Manhattan, KS, USA, 22–24 September 2013; doi:10.1109/NAPS.2013.6666929.
  18. Silva, V.; Lopez-Botet-Zulueta, M.; Wang, Y. Impact of high penetration of variable renewable generation on frequency dynamics in the continental Europe interconnected system. *IET Renew. Power Gener.* **2015**, doi:10.1049/iet-rpg.2015.0141.
  19. Zhang, Y.; Mensah-Bonsu, C.; Walke, P.; Arora, S.; Pierce, J. Transient over-voltages in high voltage grid-connected PV solar interconnection. In Proceedings of the IEEE PES General Meeting, Providence, RI, USA, 25–29 July 2010; doi:10.1109/PES.2010.5589731.
  20. Mahalakshmi, D.; Archana, V.S.; Komathi, J. Reactive power control in microgrid by using Photovoltaic Generators. In Proceedings of the 2016 International Conference on Computation of Power, Energy, Information and Communication (ICCPEIC), Chennai, India, 20–21 April 2016; doi:10.1109/ICCPEIC.2016.7557322.
  21. Eftekharnjad, S.; Vittal, V.; Heydt, G.T.; Keel, B.; Loehr, J. Small Signal Stability Assessment of Power Systems with Increased Penetration of Photovoltaic Generation: A Case Study. *IEEE Trans. Sustain. Energy* **2013**, *4*, 960–967.
  22. Tamimi, B.; Canizares, C.; Bhattacharya, K. System stability impact of large-scale and distributed solar photovoltaic generation: The case of Ontario, Canada. *IEEE Trans. Sustain. Energy* **2013**, *4*, 680–688, doi:10.1109/TSTE.2012.2235151.
  23. Liu, S.; Liu, P.X.; Wang, X. Stochastic small-signal stability analysis of grid-connected photovoltaic systems. *IEEE Trans. Ind. Electron.* **2016**, doi:10.1109/TIE.2015.2481359.

24. Munkhchuluun, E.; Meegahapola, L.; Vahidnia, A. Impact on rotor angle stability with high solar-PV generation in power networks. In Proceedings of the 2017 IEEE PES Innovative Smart Grid Technologies Conference Europe (ISGT-Europe 2017), Torino, Italy, 26–29 September 2017; doi:10.1109/ISGTEurope.2017.8260229.
25. Lashab, A.; Sera, D.; Martins, J.; Guerrero, J.M. Model predictive-based direct battery control in PV fed Quasi Z-source inverters. In Proceedings of the 2018 5th International Symposium on Environment-Friendly Energies and Applications (EFEA), Rome, Italy, 24–26 September 2018; doi:10.1109/EFEA.2018.8617084.
26. Eftekharijad, S.; Vittal, V.; Heydt, G.T.; Keel, B.; Loehr, J. Impact of increased penetration of photovoltaic generation on power systems. *IEEE Trans. Power Syst.* **2013**, *28*, 893–901, doi:10.1109/TPWRS.2012.2216294.
27. Tan, Y.T.; Kirschen, D.S. Impact on the power system of a large penetration of photovoltaic generation. In Proceedings of the 2007 IEEE Power Engineering Society General Meeting (PES), Tampa, FL, USA, 24–28 June 2007; doi:10.1109/PES.2007.385563.
28. EUROSTAG Release. 4.2 Package Documentation Part I. 2000. Available online: <http://www.eurostag.be/en/products/eurostag/eurostag-release/eurostag-release/> (accessed on 3 October 2019).
29. Omran, W.A.; Kazerani, M.; Salama, M.M.A. A clustering-based method for quantifying the effects of large on-grid PV systems. *IEEE Trans. Power Deliv.* **2010**, *25*, 2617–2625, doi:10.1109/TPWRD.2009.2038385.
30. Zhang, Y.; Zhu, S.; Sparks, R.; Green, I. Impacts of solar PV generators on power system stability and voltage performance. In Proceedings of the IEEE Power and Energy Society General Meeting, San Diego, CA, USA, 22–26 July 2012; doi:10.1109/PESGM.2012.6344990.
31. Martins, J.; Spataru, S.; Sera, D.; Stroe, D.-I.; Lashab, A. Comparative study of ramp-rate control algorithms for PV with energy storage systems. *Energies* **2019**, *12*, 1342.
32. Lashab, A.; Sera, D.; Guerrero, J.M. A low-computational high-performance model predictive control of single phase battery assisted Quasi Z-source PV inverters. In Proceedings of the 2019 10th International Conference on Power Electronics and ECCE Asia (ICPE 2019—ECCE Asia), Busan, Korea, 27–30 May 2019; pp. 1873–1878.
33. Luthander, R.; Lingfors, D.; Widén, J. Large-scale integration of photovoltaic power in a distribution grid using power curtailment and energy storage. *Sol. Energy* **2017**, *155*, 1319–1325, doi:10.1016/j.solener.2017.07.083.
34. Ina, N.; Yanagawa, S.; Kato, T.; Suzuoki, Y. Smoothing of PV system output by tuning MPPT control. *Electr. Eng. Jpn.* **2005**, *152*, 10–17, doi:10.1002/ej.20106.
35. Tonkoski, R.; Lopes, L.A.C.; El-Fouly, T.H.M. Coordinated active power curtailment of grid connected PV inverters for overvoltage prevention. *IEEE Trans. Sustain. Energy* **2011**, *2*, 139–147, doi:10.1109/TSTE.2010.2098483.
36. Zarina, P.P.; Mishra, S.; Sekhar, P.C. Exploring frequency control capability of a PV system in a hybrid PV-rotating machine-without storage system. *Int. J. Electr. Power Energy Syst.* **2014**, *60*, 258–267, doi:10.1016/j.ijepes.2014.02.033.
37. Yang, Y.; Enjeti, P.; Blaabjerg, F.; Wang, H. Suggested grid code modifications to ensure wide-scale adoption of photovoltaic energy in distributed power generation systems. In Proceedings of the 2013 IEEE Industry Applications Society Annual Meeting, Lake Buena Vista, FL, USA, 6–11 October 2013; doi:10.1109/IAS.2013.6682485.
38. Mendes, F.E.G.; Brandao, D.I.; Silva, S.M.; Pires, I.A. Reactive power injection strategies for three-phase four-wire inverters under symmetrical voltage sags. In Proceedings of the 14th Brazilian Power Electronics Conference (COBEP 2017), Juiz de Fora, Brazil, 19–22 November 2017; doi:10.1109/COBEP.2017.8257259.
39. Zhou, L.; Chao, Y. The research of reactive power control strategy for grid-connected photovoltaic plants. In Proceedings of the 2013 World Congress on Sustainable Technologies (WCST 2013), London, UK, 9–12 December 2013; doi:10.1109/WCST.2013.6750396.
40. Minambres-Marcos, V.; Guerrero-Martinez, M.A.; Romero-Cadaval, E.; Gonzalez-Castrillo, P. Point of common coupling voltage regulation with photovoltaic power plant infrastructures. In Proceedings of the IEEE International Symposium on Industrial Electronics, Istanbul, Turkey, 1–4 June 2014; doi:10.1109/ISIE.2014.6864933.

41. Van Dao, T.; Nguyen, H.T.N.; Chaitusaney, S.; Chatthaworn, R. Local reactive power control of PV plants for voltage fluctuation mitigation. In Proceedings of the 2014 11th International Conference on Electrical Engineering/Electronics, Computer, Telecommunications and Information Technology (ECTI-CON 2014), Nakhon Ratchasima, Thailand, 14–17 May 2014; doi:10.1109/ECTICon.2014.6839808.
42. Xiao, W.; Torchyian, K.; El Moursi, M.S.; Kirtley, J.L. Online supervisory voltage control for grid interface of utility-level PV plants. *IEEE Trans. Sustain. Energy* **2014**, *5*, 843–853, doi:10.1109/TSTE.2014.2306572.
43. Kobayashi, H. Fault ride through requirements and measures of distributed PV systems in Japan. In Proceedings of the IEEE Power and Energy Society General Meeting, San Diego, CA, USA, 22–26 July 2012; doi:10.1109/PESGM.2012.6345319.
44. Islam, G.M.S.; Al-Durra, A.; Muyeen, S.M.; Tamura, J. A robust control scheme to enhance the stability of a grid-connected large scale photovoltaic system. In Proceedings of the IEEE Power Engineering Society Transmission and Distribution Conference, Orlando, FL, USA, 7–10 May 2012; doi:10.1109/TDC.2012.6281420.
45. Saeedul Islam, G.M.; Al-Durra, A.; Muyeen, S.M.; Tamura, J. Low voltage ride through capability enhancement of grid connected large scale photovoltaic system. In Proceedings of the 37th Annual Conference of the IEEE Industrial Electronics Society, Melbourne, Australia, 7–10 November 2011; doi:10.1109/IECON.2011.6119427.
46. Zhang, Y.; Ma, L.; Zheng, T.Q. Application of feedback linearization strategy in voltage fault ride-through for photovoltaic inverters. In Proceedings of the 37th Annual Conference of the IEEE Industrial Electronics Society, Melbourne, Australia, 7–10 November 2011; doi:10.1109/IECON.2011.6120080.
47. Hao, T.; Feng, G.; Cong, M. Novel low voltage ride through strategy of single-stage grid-tied photovoltaic inverter with supercapacitor coupled. In Proceedings of the 2012 IEEE 7th International Power Electronics and Motion Control Conference, Harbin, China, 2–5 June 2012; doi:10.1109/IPEMC.2012.6258999.
48. Hu, J.; Zhu, J.; Dorrell, D.G. Model predictive control of grid-connected inverters for PV systems with flexible power regulation and switching frequency reduction. *IEEE Trans. Ind. Appl.* **2015**, *51*, 587–594, doi:10.1109/TIA.2014.2328785.
49. Errouissi, R.; Muyeen, S.M.; Al-Durra, A.; Leng, S. Experimental validation of a robust continuous nonlinear model predictive control based grid-interlinked photovoltaic inverter. *IEEE Trans. Ind. Electron.* **2016**, *63*, 4495–4505, doi:10.1109/TIE.2015.2508920.
50. Ouchen, S.; Betka, A.; Abdeddaim, S.; Menadi, A. Fuzzy-predictive direct power control implementation of a grid connected photovoltaic system, associated with an active power filter. *Energy Convers. Manag.* **2016**, *122*, 515–525, doi:10.1016/j.enconman.2016.06.018.
51. Merabet, A.; Labib, L.; Ghias, A.M.Y.M. Robust model predictive control for photovoltaic inverter system with grid fault ride-through capability. *IEEE Trans. Smart Grid* **2018**, *9*, 5699–5709, doi:10.1109/TSG.2017.2694452.
52. Lashab, A.; Bouzid, A.; Snani, H. Comparative study of three MPPT algorithms for a photovoltaic system control. In Proceedings of the 2015 World Congress on Information Technology and Computer Applications (WCITCA), Hammamet, Tunisia, 11–13 June 2015; pp. 1–5.
53. Lashab, A.; Sera, D.; Guerrero, J.M.; Mathe, L.; Bouzid, A. Discrete model-predictive-control-based maximum power point tracking for PV systems: Overview and evaluation. *IEEE Trans. Power Electron.* **2018**, *33*, 7273–7287.
54. Subudhi, B.; Pradhan, R. A comparative study on maximum power point tracking techniques for photovoltaic power systems. *IEEE Trans. Sustain. Energy* **2013**, *4*, 89–98.
55. Elgendy, M.A.; Zahawi, B.; Atkinson, D.J. Assessment of perturb and observe MPPT algorithm implementation techniques for PV pumping applications. *IEEE Trans. Sustain. Energy* **2012**, *3*, 21–33.
56. Liu, B.; Duan, S.; Liu, F.; Xu, P. Analysis and improvement of maximum power point tracking algorithm based on incremental conductance method for photovoltaic array. In Proceedings of the Seventh International Conference on Power Electronics and Drive Systems, Bangkok, Thailand, 27–30 November 2007; pp. 637–641.
57. Lashab, A.; Sera, D.; Guerrero, J.M. A dual-discrete model predictive control-based MPPT for PV systems. *IEEE Trans. Power Electron.* **2019**, *34*, 9686–9697.
58. Lashab, A.; Sera, D.; Martins, J.; Guerrero, J. Dual-input Quasi Z-source PV inverter: Dynamic modeling, design, and control. *IEEE Trans. Ind. Electron.* **2019**, in press, doi:10.1109/TIE.2019.2935927.

59. Gounden, N.A.; Peter, S.A.; Nallandula, H.; Krithiga, S. Fuzzy logic controller with MPPT using line-commutated inverter for three-phase grid-connected photovoltaic systems. *Renew. Energy* **2009**, *34*, 909–915.
60. Hadji, S.; Gaubert, J.P.; Krim, F. Theoretical and experimental analysis of genetic algorithms based MPPT for PV systems. *Energy Procedia* **2015**, *74*, 772–787.
61. Sarvi, M.; Ahmadi, S.; Abdi, S. A PSO-based maximum power point tracking for photovoltaic systems under environmental and partially shaded conditions. *Prog. Photovolt. Res. Appl.* **2015**, *23*, 201–214.
62. Soufyane Benyoucef, A.; Chouder, A.; Kara, K.; Silvestre, S. Artificial bee colony based algorithm for maximum power point tracking (MPPT) for PV systems operating under partial shaded conditions. *Appl. Soft Comput.* **2015**, *32*, 38–48.
63. Zhang, Y.; Wang, S.; Ji, G. A Comprehensive Survey on Particle Swarm Optimization Algorithm and Its Applications. *Math. Probl. Eng.* **2015**, *2015*, 931256.
64. Sundareswaran, K.; Palani, S. Application of a combined particle swarm optimization and perturb and observe method for MPPT in PV systems under partial shading conditions. *Renew. Energy* **2015**, *75*, 308–317.
65. Jin, Y.; Hou, W.; Li, G.; Chen, X. A glowworm swarm optimization-based maximum power point tracking for photovoltaic/thermal systems under non-uniform solar irradiation and temperature distribution. *Energies* **2017**, *10*, 541.
66. Jolly, M.; Prabhakar, A.; Sturzu, B.; Hollstein, K.; Singh, R.; Thomas, S.; Foote, P.; Shaw, A. Review of nondestructive testing (NDT) techniques and their applicability to thick walled composites. *Procedia CIRP* **2015**, *38*, 129–136.
67. Pera, D.; Silva, J.A.; Costa, S.; Serra, J.M. Investigating the impact of solar cells partial shading on photovoltaic modules by thermography. In Proceedings of the 2017 IEEE 44th Photovoltaic Specialist Conference (PVSC), Washington, DC, USA, 25–30 June 2017.
68. Cioaca, C.; Pop, S.; Boscoianu, E.C.; Boscoianu, M. Aerial Infrared Thermography: A scalable procedure for photovoltaics inspections based on efficiency and flexibility. *Appl. Mech. Mater.* **2015**, *772*, 546–551.
69. Grimaccia, F.; Leva, S.; Dolara, A.; Aghaei, M. Survey on PV modules' common faults after an O&M flight extensive campaign over different plants in Italy. *IEEE J. Photovolt.* **2017**, *7*, 810–816.
70. Dalsass, M.; Scheuerpflug, H.; Fecher, F.W.; Buerhop-Lutz, C.; Camus, C.; Brabec, C.J. Correlation between the generated string powers of a photovoltaic: Power plant and module defects detected by aerial thermography. In Proceedings of the 2016 IEEE 43rd Photovoltaic Specialists Conference, Portland, OR, USA, 5–10 June 2016; pp. 3113–3118.
71. De Oliveira, A.K.V.; Aghaei, M.; Madukanya, U.E.; Nascimento, L.; Rütther, R. Aerial Infrared Thermography of a Utility-Scale PV Plant After a Meteorological Tsunami in Brazil. In Proceedings of the 2018 IEEE 7th World Conference on Photovoltaic Energy Conversion, Waikoloa Village, HI, USA, 10–15 June 2018.
72. Tsanakas, J.A.; Ha, L.; Buerhop, C. Faults and infrared thermographic diagnosis in operating c-Si photovoltaic modules: A review of research and future challenges. *Renew. Sustain. Energy Rev.* **2016**, *62*, 695–709.

