



**AALBORG UNIVERSITY**  
DENMARK

**Aalborg Universitet**

## **Novel Cooperative Spectrum Sensing Methods And Their Limitations**

Kiilerich Pratas, Nuno

*Publication date:*  
2012

*Document Version*  
Accepted author manuscript, peer reviewed version

[Link to publication from Aalborg University](#)

*Citation for published version (APA):*  
Kiilerich Pratas, N. (2012). *Novel Cooperative Spectrum Sensing Methods And Their Limitations*.

### **General rights**

Copyright and moral rights for the publications made accessible in the public portal are retained by the authors and/or other copyright owners and it is a condition of accessing publications that users recognise and abide by the legal requirements associated with these rights.

- Users may download and print one copy of any publication from the public portal for the purpose of private study or research.
- You may not further distribute the material or use it for any profit-making activity or commercial gain
- You may freely distribute the URL identifying the publication in the public portal -

### **Take down policy**

If you believe that this document breaches copyright please contact us at [vbn@aub.aau.dk](mailto:vbn@aub.aau.dk) providing details, and we will remove access to the work immediately and investigate your claim.

NOVEL COOPERATIVE SPECTRUM SENSING METHODS  
AND THEIR LIMITATIONS

A DISSERTATION  
SUBMITTED TO THE DEPARTMENT OF  
ELECTRONIC SYSTEMS  
OF  
AALBORG UNIVERSITY  
IN PARTIAL FULFILLMENT OF THE REQUIREMENTS  
FOR THE DEGREE OF  
DOCTOR OF PHILOSOPHY

Nuno Manuel Kiilerich Pratas  
Center for TeleInFrastruktur, Instituto the Telecomunicações

**Supervisor:**

Professor Ramjee Prasad, Aalborg University, Denmark

Associate Professor Neeli Rashmi Prasad, Aalborg University, Denmark

Assistant Professor António Rodrigues, Instituto Superior Técnico, Universidade  
Técnica de Lisboa, Portugal

**The examination committee:**

Professor Kwang-Cheng Chen

Professor Rajarathnam Chandramouli

Associate Professor Albena Mihovska (Chairman)

**Moderator:**

Associate Professor Flemming Bjerger Frederiksen

**Date of defence:** 4<sup>th</sup> April of 2012

ISBN: 978-87-92328-79-3

Copyright © 2013 by Nuno Manuel Kiilerich Pratas

Center for TeleInFrastruktur, Instituto the Telecomunicações

All rights reserved. No part of the material protected by this copyright notice may be reproduced or utilized in any form or by any means, electronic or mechanical, including photocopying, recording or by any information storage and retrieval system, without written permission from the author.

# Abstract

The rapid growth of services offered through wireless communication has as consequence an increase on the demand for electromagnetic radio frequency spectrum, which is a scarce resource, mainly assigned to license holders on a long-term basis for large geographical regions, causing a large portion of the spectrum to remain unused for a significant percentage of the time. A new paradigm – to overcome this apparent spectrum shortage – that consists of radio devices with the ability to adapt to their spectral environment and are therefore able to make use of the available spectrum in an opportunistic manner was put forward, i.e. the Cognitive Radio paradigm.

Spectrum sensing is the key mechanism in enabling spectrum awareness in Cognitive Radio. The performance of the spectrum sensing depends on the local channel conditions, such as the multipath, shadowing and the receiver uncertainty issues. The conjunction of these conditions can result in regimes where the signal strength is below the detection threshold of the sensor, resulting in missed detections.

To overcome this limitation, there have been several proposals made in the research community towards the use of cooperation in spectrum sensing. Since the signal strength varies with the sensor location, the worst fading conditions can be avoided if multiple sensors in different spatial locations share their local sensing measurements, i.e. take advantage of the spatial diversity.

In this thesis a Cooperative Spectrum Sensing mechanism is proposed. While identifying the key components needed to enable such mechanism, an analysis is presented regarding the correctness of the class of protocols which enable the Cooperative Spectrum Sensing mechanism. This is done by proposing and employing a process calculus variant of the  $\pi$ -calculus, denoted as Bounded Broadcast Calculus. This analysis is done over centralized, decentralized and relay aided topologies. The outcome of this analysis is a theorem where it is stated, which properties a protocol should have so that it can be

---

deemed correct, i.e. that it performs as intended, over each of the considered network topologies.

The performance of data fusion schemes based on counting rules is analyzed, which lead to the proposal of an adaptive counting rule algorithm that adapts the decision threshold according to the performance of the local detectors. A study is done about the impact of using local detectors in the data fusion scheme which are experiencing different channel conditions, i.e. some of these local detectors are experiencing the channel as free while others as occupied. In this analysis it is measured what is the impact of using data fusion in these cases, and whether it improves the detection of the resources available. Based on these insights a cluster based data fusion algorithm is proposed, which uses the correlation measured between the decisions of the local detectors over time to group the local detectors together in different clusters, and then apply the adaptive counting rule data fusion algorithm separately to each of the defined clusters. It was observed, in the case of a single signal source, that the proposed algorithm performance in regards to identified spectrum resources is almost the same as the theoretical maximum, and superior to the case where the local detectors are not divided in clusters.

Finally, a node selection mechanism which assigns the local detectors to the channel that most likely will be experienced vacant by the local detector is proposed. The purpose of using such scheme is twofold, one is to ensure that the correct amount of the local detectors is sensing each channel; the other is to increase the probability of the network finding a channel available to be used. This is accomplished by assigning the local detectors to channels that have a higher probability of being available and where most likely the local detector is outside the range of the signal source. The node selection scheme is proposed in a centralized and in a decentralized version. These versions can complement each other and therefore lead to a more robust cooperative spectrum sensing mechanism.

# Dansk Resume

Den hastige vækst indenfor serviceydelser, der tilbydes via trådløs kommunikation, har betydet en stigende efterspørgsel på elektromagnetisk radiofrekvens spektrum. Dette er en begrænset ressource primært tildelt licensindehavere gennem en længere periode over store geografiske områder, hvilket medfører, at en stor del af spektret forbliver ubrugt i en betydelig del af tiden. For at forbedre udnyttelsen af spektret er et nyt paradigme blevet fremsat, hvori radio-enheder er i stand til at tilpasse sig deres spektrale miljø og til at gøre brug af de tilgængelige frekvensressourcer på en opportunistisk måde, dvs. Cognitive Radio paradigmet.

*Spectrum sensing* er den centrale mekanisme, der giver kendskab til spektrets udnyttelse indenfor Cognitive Radio. Udførelsen af spectrum sensing afhænger af de lokale kanalforhold, såsom refleksioner, skygger og modtager-usikkerhed. Kombinationen af disse kanalforhold kan resultere i situationer, hvor signalstyrken er under detektionsgrænsen for sensoren, hvilket resulterer i manglende registreringer.

For at overvinde dette problem med de manglende registreringer, er der blevet fremsat forskellige forslag i forskerkredse om brugen af samarbejde mellem sensorer. Eftersom signalstyrken varierer med sensorens placering, kan de værste problemer undgås, hvis flere sensorer på forskellige steder deler deres lokale målinger og dermed drager fordel af den rumlige forskellighed.

I denne afhandling bliver en kooperativ Spectrum Sensing mekanisme foreslået. Først identificeres de centrale komponenter, der kræves til sådan en mekanisme og derefter præsenteres en analyse af korrektheden af den klasse af protokoller, som benyttes til sådan en mekanisme. Dette gøres ved at foreslå og benytte en proces calculus variant af  $\pi$ -calculus, betegnet som Bounded Broadcast Calculus. Denne analyse er lavet over centraliserede, decentraliserede og radio-relæ-støttede topologier. Resultatet af denne analyse er et teorem, hvor det er angivet, hvilke egenskaber en protokol bør have, så den kan anses for

---

korrekt: at den virker efter hensigten i hver af de pågældende netværkstopologier.

Derefter analyseres ydelsen af forskellige metoder til datafusion baseret på tælleregler, som fører til forslaget om en adaptiv tælleregel algoritme, der tilpasser grænseværdien i forhold til præstationen af de lokale detektorer. En undersøgelse er udført over konsekvenserne af at bruge lokale detektorer i en datafusionsordning, der oplever forskellige kanalforhold, dvs. nogle af disse lokale detektorer registrerer kanalen som ledig, mens andre som optaget. I denne analyse bliver det målt, hvad virkningen af at anvende datafusion i disse tilfælde er, og om det forbedrer detektion af de ressourcer, der er til rådighed. På baggrund af denne viden foreslås en klynge-baseret datafusion-algoritme, som bruger korrelationen målt mellem resultaterne fra de lokale detektorer over tid til at gruppere de lokale detektorer sammen, og derefter anvende den adaptive tælleregel datafusion-algoritme særskilt til hver af de definerede klynger. Med én enkelt signalkilde blev det observeret, at den foreslåede algoritmes ydelse i forhold til identificerede frekvensressourcer er næsten den samme som det teoretiske maksimum, og overlegen i forhold til når de lokale detektorer ikke er opdelt i klynger.

Endelig foreslås en nodeudvælgelsesmekanisme, der tildeler de lokale detektorer til den kanal, der med højest sandsynlighed vil blive registreret som ledig af den lokale detektor. Der er to formål med at bruge sådan en ordning: den ene er at sikre, at den rigtige mængde af de lokale detektorer registrerer hver kanal, den anden er at øge sandsynligheden for at netværket finder en ledig kanal. Dette opnås ved at tildele de lokale detektorer til kanaler, der har en højere sandsynlighed for at være ledige, og hvor den lokale detektor højst sandsynligt er uden for rækkevidde af signalkilden. Denne nodeudvælgelsesordning er foreslået i en centraliseret og en decentraliseret udgave. Disse udgaver kan supplere hinanden, og føre til en mere robust kooperativ spektrum sensing mekanisme.

# Acknowledgements

I would like to thank my supervisors Prof. Ramjee Prasad, Neeli R. Prasad, and António Rodrigues for all the support and feedback, which without I would not be able to complete my research work and write this thesis. I would like also to thank Nicola Marchetti for all his support and comments in the first half of my research period. I would also like to thank Hans Hüttel for his patience and guidance in the abstract world of process calculus.

I would like to thank to the Portuguese Fundação para a Ciência e Tecnologia which sponsored my research activities through a Doctoral grant, under the grant SFRH/BD/36454/2007 from the *Programa Operacional Potencial Humano of QREN Portugal 2007-2013*.

I would like to thank my colleagues, the current ones and the ones that have already gone from Aalborg University to pursue new challenges, for their friendship and for withstanding my overly long presentations, and then give precious feedback. From those I would like to thank especially to Rasmus H. Nielsen, for his friendship and for putting up with my long discussions about research. I would like also to thank Jimmy J. Nielsen, for his friendship, for trying to teach me Danish and for correcting the Danish version of this thesis abstract.

I would like also to thank Dorthe Sparre, Susanne Nørrevang and Inga Hauge for their help during my stay at Aalborg University.

Last I would like to thank my family for all the support during this sometimes trying period of my life. Especially my wife and daughter for putting up with me working on weekends.

Thank you all :)





# Table of Contents

<b>List Of Figures</b>	<b>xv</b>
<b>List Of Tables</b>	<b>xvii</b>
<b>List of Acronyms</b>	<b>xxi</b>
<b>1 Introduction</b>	<b>1</b>
1.1 Cognitive Radio Fundamentals . . . . .	2
1.2 Cognitive Radio Functions . . . . .	4
1.2.1 Spectrum Sensing . . . . .	5
1.2.2 Spectrum Analysis . . . . .	6
1.2.3 Spectrum Decision . . . . .	7
1.2.4 Spectrum Mobility . . . . .	8
1.2.5 Spectrum Sharing . . . . .	9
1.2.6 Physical Architecture and Re-configurability . . . . .	12
1.3 Motivation . . . . .	13
1.4 Problem Definition . . . . .	18
1.5 Original Contributions and Publications . . . . .	18
1.6 Thesis Outline . . . . .	22
<b>2 State of the Art</b>	<b>29</b>
2.1 Introduction . . . . .	29
2.2 Spectrum Sensing . . . . .	30
2.3 Local Decision Reporting . . . . .	34
2.4 Local Decisions Fusion . . . . .	35
2.5 Knowledge Base Update . . . . .	36
2.6 Node Selection . . . . .	37
2.7 Gain and Overhead . . . . .	38
2.8 Conclusions . . . . .	38

---

**TABLE OF CONTENTS**

---

<b>3</b>	<b>Reasoning about Distributed Cooperative Spectrum Sensing Protocols Correctness</b>	<b>43</b>
3.1	Introduction . . . . .	43
3.2	Reasoning about protocols using process calculi . . . . .	45
3.3	Network Description . . . . .	48
3.4	Bounded Broadcast Calculus . . . . .	49
3.4.1	Syntax . . . . .	49
3.4.2	Structural congruence and normal form . . . . .	51
3.4.3	Reduction Semantics . . . . .	53
3.5	Centralized Topology Description . . . . .	55
3.5.1	Spectrum Sensing . . . . .	56
3.5.2	Data Fusion and Knowledge Base Update . . . . .	56
3.5.3	Node Selection . . . . .	58
3.6	Decentralized Topology Description . . . . .	58
3.6.1	Spectrum Sensing . . . . .	59
3.6.2	Data Fusion and Knowledge Base Update . . . . .	59
3.6.3	Node Selection . . . . .	60
3.7	Relay Based Topology Description . . . . .	60
3.7.1	Relay Process . . . . .	61
3.8	Correctness . . . . .	62
3.8.1	The Centralized Case . . . . .	64
3.8.2	The Decentralized Case . . . . .	65
3.8.3	The Relay Case . . . . .	66
3.9	Conclusions . . . . .	67
<b>4</b>	<b>Data Fusion of Local Spectrum Sensing Decisions</b>	<b>71</b>
4.1	Introduction . . . . .	71
4.2	Motivation for the use of Counting Rules . . . . .	73
4.3	Counting Rules Theoretical Formulation . . . . .	76
4.4	Performance Evaluation Metrics . . . . .	80
4.4.1	Local Detector Model . . . . .	84
4.4.2	Duty-Cycle . . . . .	84
4.5	Non-Identical Local Detectors . . . . .	85
4.6	Adaptive Counting Rule . . . . .	89
4.7	Capacity Limits introduced by Data Fusion . . . . .	97
4.7.1	System Capacity Metrics . . . . .	98
4.7.2	Effect of Environment Correlation on System Capacity . . . . .	104
4.7.3	Effect of Number of Network Nodes on System Capacity . . . . .	109
4.7.4	Effect of Channel Occupation on System Capacity . . . . .	110
4.7.5	Considerations on how to increase System Capacity . . . . .	111
4.8	Cluster based Adaptive Counting Rule . . . . .	113

## TABLE OF CONTENTS

---

4.9	Conclusions . . . . .	122
<b>5</b>	<b>Node Selection Mechanisms</b>	<b>127</b>
5.1	Introduction . . . . .	127
5.2	Multi Channel Sensing . . . . .	128
5.3	Node Selection Rationale . . . . .	131
5.4	Node Selection Fundamentals . . . . .	132
5.5	Node Selection Mechanism . . . . .	134
5.5.1	Centralized Mechanism . . . . .	134
5.5.2	Decentralized Mechanism . . . . .	135
5.5.3	Implementation Constraints . . . . .	136
5.6	Performance Comparison . . . . .	138
5.7	Conclusions . . . . .	138
<b>6</b>	<b>Conclusions and Outlook</b>	<b>141</b>
6.1	Conclusions . . . . .	141
6.2	Outlook . . . . .	144
<b>A</b>	<b>Appendix - Centralized Topology Induction Proof</b>	<b>147</b>
A.1	Base-Case . . . . .	148
A.2	$N + 1$ Case . . . . .	152
A.2.1	$N + 1 < b(cc, cl)$ . . . . .	154
A.2.2	$N + 1 > b(cc, cl)$ . . . . .	156
<b>B</b>	<b>Appendix - Decentralized Topology Induction Proof</b>	<b>159</b>
B.1	Base-Case . . . . .	160
B.1.1	$ I  = 1$ . . . . .	160
B.1.2	$ I  = 2$ . . . . .	164
B.2	$N + 1$ Case . . . . .	170
B.2.1	$N + 1 < b(cc, sl_i)$ . . . . .	173
B.2.2	$N + 1 > b(cc, sl_i)$ . . . . .	176
<b>C</b>	<b>Appendix - Relay Topology Induction Proof</b>	<b>181</b>
C.1	Base Case . . . . .	182
C.2	$N+1$ Case . . . . .	188
C.2.1	Induction in $ J $ . . . . .	189
C.2.2	Induction in $ I $ . . . . .	195
<b>D</b>	<b>Appendix - Channel Duty Cycle Estimation</b>	<b>205</b>
D.1	Exponential Moving Average Estimator . . . . .	206
D.1.1	Linear Moving Average Estimator . . . . .	206
D.1.2	Implementation Issues and Performance Comparison . . . . .	207



# List of Figures

1.1	Spectrum hole concept . . . . .	3
1.2	OSI model updated with the Cognitive Radio functionalities . . . . .	4
1.3	The cognitive cycle . . . . .	5
1.4	Representation of sensing from a cognitive radio prespective . . . . .	7
1.5	Cognitive radio transceiver. . . . .	13
1.6	(a) Hidden Node Problem, (b) Exposed Node Problem . . . . .	16
1.7	Receiver sensitivity . . . . .	17
1.8	The drawback of using data fusion, the loss of spatial diversity . . . . .	19
1.9	Thesis Outline . . . . .	23
2.1	Distributed spectrum sensing mechanism flow . . . . .	30
2.2	Energy Detector Implementation a) with analog pre-filter and square-law device b) implementation using periodogram: FFT magnitude squared and averaging . . . . .	32
2.3	(a) Centralized Topology, (b) Decentralized Topology, (c) Relay aided Topology . . . . .	35
3.1	Distributed spectrum sensing mechanism flow . . . . .	44
3.2	(a) Centralized Topology, (b) Decentralized Topology, (c) Relay Topology . . . . .	45
3.3	Control Frame: (a) centralized, (b) decentralized, (c) relay aided . . . . .	45
3.4	A simple protocol . . . . .	47
4.1	Distributed cooperative spectrum sensing flow . . . . .	72
4.2	Two-level distributed detection system . . . . .	73
4.3	(a,b) $GP_x$ and $mC$ variation with $c$ , where $k = 10$ and $p_x = 0.5$ . . . . .	79
4.4	(a,b) $GP_x$ and $mK$ variation with $K$ , where $c = 40$ and $p_x = 0.5$ . . . . .	81
4.5	(a,b) $GP_x$ and $mP$ variation with $p_x$ , where $c = 40$ and $k = 10$ . . . . .	82
4.6	Representation of sensing from a cognitive radio prespective. . . . .	82
4.7	Confusion Table . . . . .	83
4.8	(a,b) $\phi$ and $\epsilon$ variation with the $k$ -threshold for different $p_d$ and $p_{fa}$ pairs, with $c = 40$ . . . . .	85

**LIST OF FIGURES**

4.9 (a) Comparison of the ROC of the ED when  $N = 250$  and  $N = 500$ , (b) Comparison of the ROC of the ED and OR rule with  $N = 250$  in a single detector and  $c = 10$  . . . . . 86

4.10 (a,b)  $\epsilon$  and  $\phi$  variation in regards to  $p_{fa}$  and  $k$ , with  $c = 40$  . . . 87

4.11 (a,b)  $\epsilon$  and  $\phi$  variation in regards to Duty Cycle and  $k$ , with  $c = 40$ ,  $p_d = 0.8$  and  $p_{fa} = 0.05$  . . . . . 88

4.12  $p_d$  of the Energy Detector in function of the experienced  $SNR$ , with  $p_{fa} = 0.05$ ,  $SNR_{Target} = 0dB$  . . . . . 89

4.13 (a,b)  $\epsilon$  and  $\phi$  variation in regards to minimum and maximum  $p_d$  and the heterogeneous  $p_d$  . . . . . 90

4.14 (a,b)  $\epsilon$  and  $\phi$  variation with heterogeneous  $p_d$  depending on  $\sigma$  . 91

4.15 (a,b)  $\epsilon$  and  $\phi$  variation with heterogeneous  $p_d$  depending on  $\sigma \in [0, 20]$  dB . . . . . 92

4.16 (a,b)  $\epsilon$  and  $\phi$  variation with  $p_{fa} \in [0.01, 0.2]$  . . . . . 92

4.17 Adaptive Counting Rule versus time. . . . . 95

4.18 Adaptive Counting Rule performance in regards to  $\phi$  versus  $MD_{Thrs}$  and  $OC_{Thrs}$  for different duty cycles, with  $\sigma = 8dB$  and  $c = 40$  . . . . . 96

4.19 (a) Optimum  $OC_{Thrs}$  which maximizes the  $\phi$  obtained by Adaptable Counting Rule (ACR) versus the duty cycle, for different  $\sigma$  and  $c = 40$  (b) Optimum  $OC_{Thrs}$  fitted curve . . . . . 97

4.20  $k$ -threshold variation of MACR and ACR vs time, with  $c = 40$ ,  $OW = 100$ ,  $MD_{Thrs} = 1$ , initial  $OC_{Thrs} = OW$  and duty cycle 0.5 . . . . . 99

4.21  $\phi$  vs duty cycle, for Modified Adaptable Counting Rule (MACR) and ACR, with  $c = 40$ ,  $OW = 100$ ,  $MD_{Thrs} = 1$  and initial  $OC_{Thrs} = OW$  . . . . . 100

4.22 The drawback of using data fusion, the loss of spatial diversity . 100

4.23 Capacity along the paralel data fusion chain . . . . . 101

4.24 Spectrum sensing capacity illustration . . . . . 102

4.25 Capacity and False Capacity metrics use illustration . . . . . 105

4.26  $\rho$  vs Noise Level at the local detectors . . . . . 106

4.27 (a) Capacity and (b) False Capacity versus average local detectors experienced correlation . . . . . 107

4.28 (a) Normalized Capacity and (b) Normalized False Capacity versus average local detectors experienced correlation . . . . . 109

4.29 (a) Capacity and (b) False Capacity versus number of local detectors . . . . . 111

4.30 (a) Capacity and (b) False Capacity versus channel occupation,  $\rho = 0.5$  and  $c = 20$  . . . . . 112

## LIST OF FIGURES

---

4.31	(a) Capacity and (b) False Capacity versus channel occupation, $\rho = 0.2$ and $c = 20$ . . . . .	113
4.32	Clustering of Local Detectors (LDs) illustration . . . . .	114
4.33	Proof of concept for the use of clustering in data fusion, $c = 40$ .	115
4.34	(a) $\phi$ (b) $\rho$ coefficients between the decisions of two LDs, with signal duty cycle of 0.5 and the LDs $p_{fa} = 0.05$ , (c) $p_d$ versus $SNR_{Exp}$ . . . . .	116
4.35	$\rho$ threshold variation evaluated through $\phi$ . . . . .	119
4.36	$\phi$ variation in regards to $\rho_{Thrs}$ and $p_d$ target, when $p_{fa}$ target is 0.05, $c = 100$ and the $SNR_{Thrs} = -5dB$ . . . . .	119
4.37	Non and clustering based data fusion algorithms comparison . .	120
4.38	$k$ -threshold variation over time, with $c = 40$ and $OW = 100$ . .	122
5.1	Distributed cooperative spectrum sensing flow . . . . .	128
5.2	Comparison between normalized $MC_r$ and $MFC_r$ for LDs able to sense multiple channels, for $m = 5$ and $m = 10$ . . . . .	130
5.3	Comparison between Node Selection (NS) strategies . . . . .	132
5.4	Performance Evaluation comparison between the proposed centralized and decentralized NS without Single Channel Assignment (SCA) and random and optimum NS . . . . .	139
5.5	Performance comparison between centralized and decentralized NS with and without SCA . . . . .	139
D.1	Channel Estimation Performance Comparison . . . . .	207





# List of Tables

2.1	Spectrum sensing method overview. . . . .	31
3.1	Formation rules . . . . .	50
3.2	Free names . . . . .	52
3.3	Structural congruence for processes . . . . .	52
3.4	Structural congruence for networks . . . . .	54
3.5	Reduction rules for networks on normal form, assuming connectivity $b(a, m)$ . . . . .	55
4.1	Relevant simulation parameters . . . . .	106



# List of Algorithms

1	Adaptive counting rule mechanism . . . . .	93
2	Modified Adaptive counting rule mechanism . . . . .	98
3	MACR integrated with single source clustering algorithm . . . .	118
4	MACR integrated with Generalized Clustering Algorithm . . . .	121
5	Centralized Node Selection Scheme . . . . .	136
6	Decentralized Node Selection Scheme . . . . .	137



# List of Acronyms

<b>CR</b> Cognitive Radio .....	1	<b>SMob</b> Spectrum Mobility .....	8
<b>SDR</b> Software Defined Radio .....	1	<b>SSh</b> Spectrum Sharing .....	9
<b>DSA</b> Dynamic Spectrum Access .....	2	<b>FCC</b> Federal Communications Commission .....	37
<b>SH</b> Spectrum Hole .....	30	<b>RF</b> Radio Frequency .....	12
<b>OSI</b> Open Systems Interconnection .....	3	<b>A2D</b> Analog to Digital .....	12
<b>SS</b> Spectrum Sensing .....	141	<b>PU</b> Primary User .....	36
<b>SA</b> Spectrum Analysis .....	4	<b>ROC</b> Receiver Operating Characteristic .....	33
<b>SD</b> Spectrum Decision .....	4	<b>NPC</b> Neyman-Pearson Criterion .....	31
<b>PHY</b> Physical Layer .....	5	<b>KB</b> Knowledge base .....	36
<b>MAC</b> Medium Access Control Layer .....	4	<b>NS</b> Node Selection .....	142
<b>ED</b> Energy Detector .....	115	<b>CN</b> Central Node .....	198
<b>SNR</b> Signal to Noise Ratio .....	99	<b>SN</b> Sensing Node .....	189
<b>CSS</b> Cooperative Spectrum Sensing .....	142	<b>SNs</b> Sensing Nodes .....	195
<b>QoS</b> Quality of Service .....	4	<b>RN</b> Relay Node .....	49
<b>RTT</b> Round Trip Time .....	4	<b>RNs</b> Relay Nodes .....	189
<b>CRN</b> Cognitive Radio Network .....	205	<b>LDDF</b> Local Decisions Data Fusion .....	142
		<b>KBU</b> Knowledge Base Update .....	142

## *LIST OF ALGORITHMS*

---

<b>CCH</b> Common Control Channel.....	44	<b>MACR</b> Modified Adaptable Counting Rule ....	95
<b>PC</b> Process Calculus.....	142	<b>DF</b> Data Fusion.....	97
<b>LD</b> Local Detector.....	142	<b>MC</b> Multichannel Capacity.....	129
<b>LDs</b> Local Detectors.....	142	<b>MFC</b> Multichannel False Capacity.....	129
<b>FuC</b> Fusion Center.....	127	<b>SCA</b> Single Channel Assignment.....	144
<b>LRT</b> Likelihood Ratio Test.....	74	<b>BBC</b> Bounded Broadcast Calculus.....	142
<b>NP</b> Neyman-Pearson.....	74	<b>TP</b> True Positives.....	80
<b>ACR</b> Adaptable Counting Rule.....	143	<b>FP</b> False Positives.....	80
<b>NFC</b> Normalized False Capacity.....	108	<b>FN</b> False Negatives.....	80
<b>FC</b> False Capacity.....	108	<b>TN</b> True Negatives.....	80
<b>C</b> Capacity.....	113		

# 1

## Introduction

The rapid growth of a multitude of wireless communication services had as a consequence the increase on the demand for electromagnetic radio frequency spectrum, which is a scarce resource, mainly assigned to license holders on a long-term basis for large geographical regions, causing, according to measurements [3], a large portion of the spectrum to remain unused for a significant percentage of the time.

Upon this scenario, the Federal Communications Commission in the United States and the European Commission's Radio Spectrum Policy Group in the European Union, proposed a secondary and concurrent usage of this spectrum, focusing on the case where this secondary system does not interfere with the normal operation of the license holders. These new regulations, in contrast with the licensed bands to which entities such as TV stations or cellular operators are granted exclusive access, allows the evolution of a new paradigm, consisting of devices with the ability to adapt to their spectral environment and able to make use of the available spectrum in an opportunistic manner, paving the way for the development of the Cognitive Radio (CR) paradigm.

The CR paradigm was first put forward by J. Mitola III in [22], as the natural evolution of the Software Defined Radio (SDR). The CR by Mitola was presented as an intelligent agent able to track radio resources and related computer-to-computer communications and able to detect user communications needs as a function of use context, and to provide radio resources and the



wireless services most appropriate to those needs. Later the focus of research in CR was directed mainly towards the intelligent and opportunistic use of the radio resources, a technique also known as Dynamic Spectrum Access (DSA).

The CR concept was then further defined in [13], and the DSA was emphasized, which led to a new CR definition: *an intelligent wireless communication system, aware of its surrounding environment (i.e., outside world), that uses the methodology of understanding-by-building to learn from the environment and to adapt its internal states to statistical variations in the incoming RF stimuli by making corresponding changes in certain operating parameters (e.g., transmit-power, carrier-frequency, and modulation strategy) in real-time, with two primary objectives in mind: highly reliable communications whenever and wherever needed and efficient use of the radio spectrum.*

As stated in the definition, the CR is a device that is aware (of its surrounding radio environment), is intelligent (as it decides the best approach to convey the wireless service), learns and adapts, is reliable and above all efficient. One of the main capabilities of the CR, is its ability to reconfigure, which is enabled by the SDR platform, upon which the CR is built [9].

Currently there are several ongoing CR standardisation efforts like IEEE 802.22 [10], IEEE 1900 [25] and the IEEE 802.11af.

## 1.1 Cognitive Radio Fundamentals

The key enabling technologies of CR are the functions that provide the capability to share the spectrum in an opportunistic manner. In [5] a summarized definition of CR was presented: *A CR is a radio that can change its transmitter parameters based on interaction with the environment in which it operates.*

Since most of the spectrum is already assigned, the challenge is to share the spectrum with coexisting networks without interfering with their transmission. For this the cognitive radio enables the usage of temporarily unused spectrum, which is referred in the literature as Spectrum Hole (SH) or white space, which is depicted in Figure 1.1. In [13], the definition of SH was given: *A SH is a band of frequencies assigned to a primary user, but, at a particular time and specific geographic location, the band is not being used by that user.* If this SH where the CR is operating starts also to be used by another secondary user, then the CR moves to another SH or stays in the same, altering its transmission power level or modulation scheme to minimize interference. Therefore the CR is a

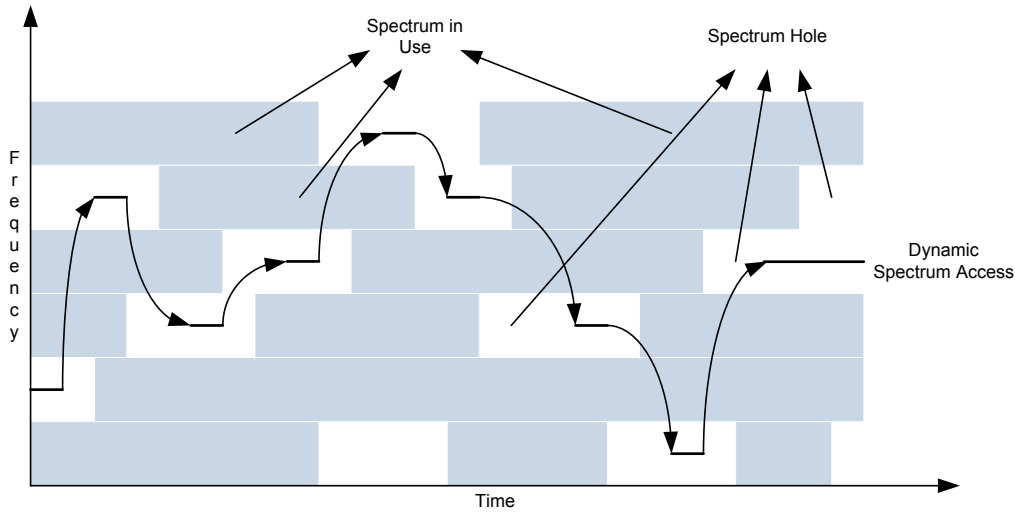

Figure 1.1: Spectrum hole concept

paradigm for the efficient and opportunistic use of the available spectrum and through it, it is possible to:

- Determine which portions of the spectrum are available;
- Select the best available channel;
- Coordinate access to this channel with other users;
- Vacate it when the channel conditions worsen.

To implement the CR paradigm a network needs to employ adaptive network protocols. Such an example is given in [5, 16], where it is proposed an cross layer adaptation approach of the Open Systems Interconnection (OSI) network model to allows the implementation of the CR paradigm. In Figure 1.2 is depicted the model proposed in [5] that is used as reference in this thesis. In this model, the spectrum sensing and spectrum sharing functions cooperate with each other to improve the network spectrum use efficiency. In the spectrum decision and spectrum mobility functions, application, transport, routing, medium access and physical layer functionalities are carried out in a cooperative way, so to allow to adapt to the dynamic nature of the underlying spectrum.

The OSI model added functionalities which implement the Cognitive Radio paradigm and their purpose are explained in the following sub-sections.

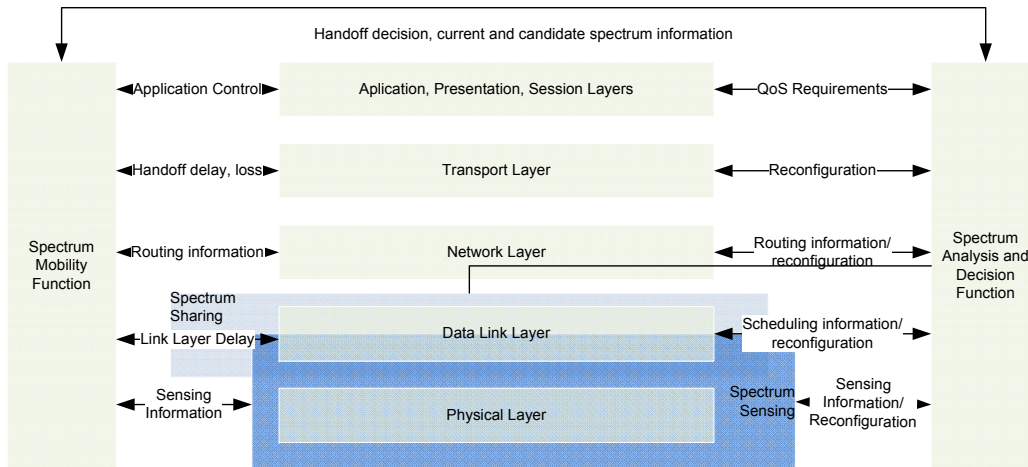

Figure 1.2: OSI model updated with the Cognitive Radio functionalities

## 1.2 Cognitive Radio Functions

The CR main goal is to enable networks to use the appropriate available spectrum band according to the network users Quality of Service (QoS) requirements. To accomplish this, new spectrum management functions are required, taking into consideration the dynamic spectrum characteristics. These functions are the Spectrum Sensing (SS), Spectrum Analysis (SA) and Spectrum Decision (SD), and their interrelation is depicted in Figure 1.3, [13].

It is expected that the SS function will find SH spread over a wide frequency range including both unlicensed and licensed bands. Therefore, these will potentially show different characteristics according not only to the time varying radio environment but also to the spectrum band information such as the operating frequency and the bandwidth.

Due to the dynamic nature of the underlying spectrum the communication protocols need to adapt to the wireless channel parameters, since the behavior of each protocol affects the performance of all the other protocols built on top of it. For example, by using different Medium Access Control Layer (MAC) techniques CR networks, the Round Trip Time (RTT) for the transport protocols will be affected. Similarly, when re-routing is done because of link failures arising from spectrum mobility, i.e. when a SH is no longer usable by the Cognitive Radio Network (CRN), the RTT and error probability in the communication path will change accordingly. The change in error probability also affects the performance of the MAC protocols. Consequently, all these changes affect the overall quality of the user applications.

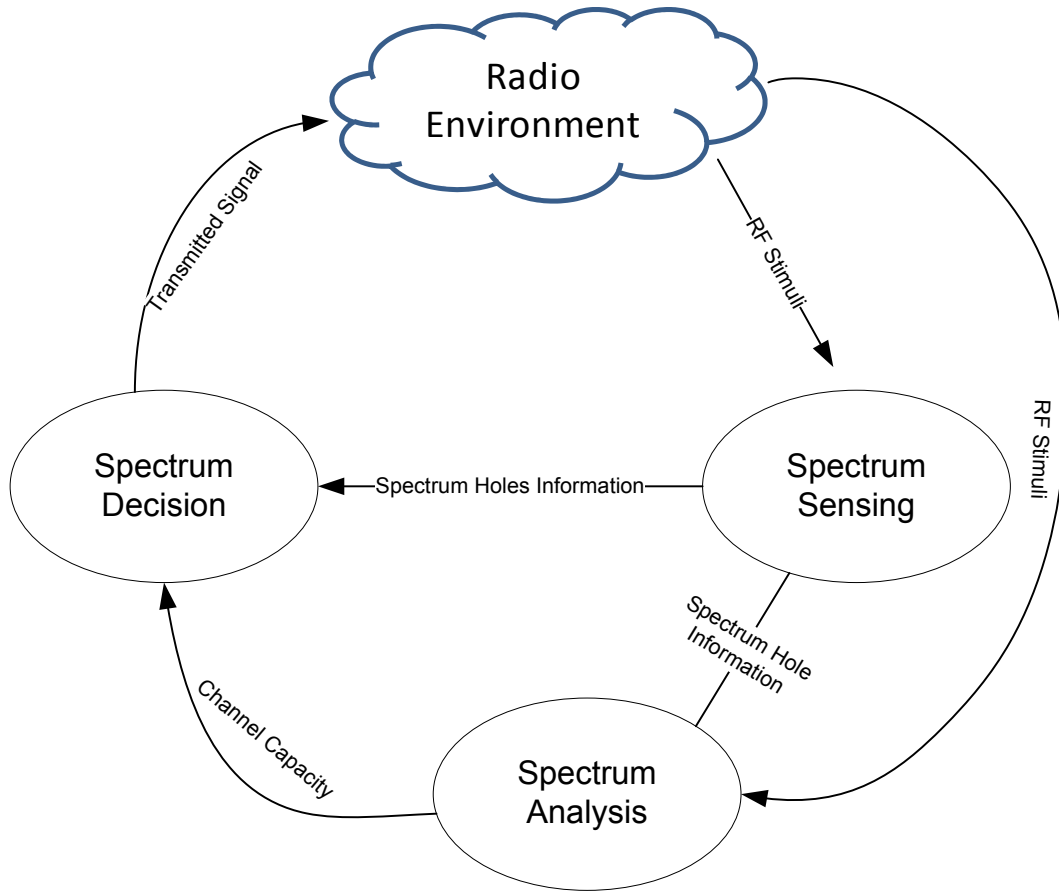

Figure 1.3: The cognitive cycle

The SA and SD function cooperate with the communication layers, as shown in Figure 1.2. In order to decide the appropriate spectrum band, the information regarding the QoS requirement, transport, routing, scheduling, and sensing is required. So the use of a cross layer approach will use the interdependencies among functionalities of the communication stack, and their close coupling with the physical layer to accomplish the SA and SD function. So, while SS is primarily a Physical Layer (PHY) and MAC issue, SA and SD are closely related to the upper layers.

### 1.2.1 Spectrum Sensing

The SS function is responsible for the monitoring of the spectrum environment at the network node position, with the purpose of detecting unused spectrum, i.e. the SH. In Figure 1.4, [28], the SS is depicted as an imperfect and simplified

mapping of the radio environment to a representation at the sensing node, which in the remaining of the thesis is denoted as Local Detector (LD). By sensing the spectrum the CR becomes aware and sensitive to the changes in its surrounding, giving to the CR the information needed to adapt to its environment.

Spectrum Sensing, is realized as a PHY and MAC mechanism [18] as depicted in Figure 1.2, and as been covered extensively in literature [5, 29, 6] and falls into the domain of the detection theory, presented in detail in [36]. While the PHY SS focuses on the detecting of signals, and the detection methods put in place can be classified into two groups, either coherent (prior information needed, e.g. Pilot Detection, [5]) or non-coherent (no prior information needed, e.g. Energy Detector (ED), [35]). The MAC part of the SS focuses on when to sense (in time) and which spectrum to sense (in frequency).

The performance of the SS depends on the local channel conditions, i.e. depend on the multipath, shadowing and local interference. The conjunction of these conditions can result in regimes where the signal Signal to Noise Ratio (SNR) is below the detection threshold of the LD, resulting in missed detections and in false alarms creating the imperfect mapping illustrated in Figure 1.4. To overcome this limitation the use of cooperation as been proposed. Since the signal strength varies with the LD location, the worst fading conditions can be avoided if multiple sensors in different spatial locations share their local sensing measurements, i.e. take advantage of the spatial diversity. The focus of this thesis is on these Cooperative Spectrum Sensing (CSS) schemes, therefore further details about the background of these can be found in Chapter 2.

## 1.2.2 Spectrum Analysis

The SH identified by the SS function have different characteristics which vary over time. The purpose of the SA function is to characterize these spectrum bands, as to identify the appropriate one for the CRN node requirements.

To account for the dynamic nature of networks, each SH should consider not only the time-varying radio environment, but also the interferers activity and the spectrum band information such as operating frequency and bandwidth. Hence, it is essential to define characterizing parameters that can represent the quality of a particular spectrum band. The following were identified in [5]:

- Interference - The spectrum band in use determines the characteristics of the interferers affecting the channel;

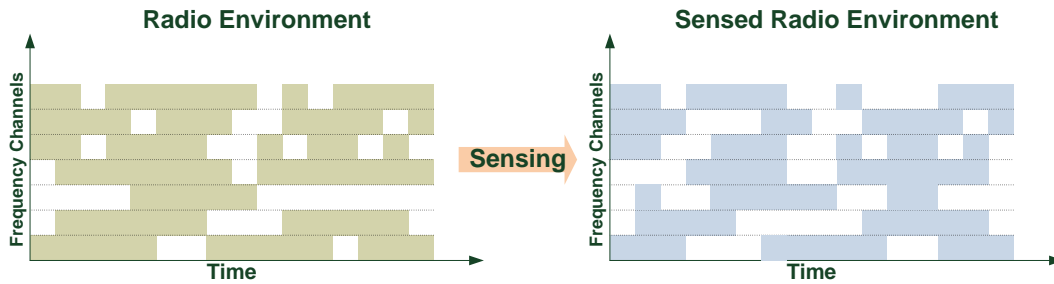

Figure 1.4: Representation of sensing from a cognitive radio perspective

- Path loss - The path loss increases as the operating frequency increases. If the transmission power of a node remains constant, then its transmission range decreases at higher frequencies;
- Link errors - Depending on the modulation scheme and the interference level of the spectrum band, the error rate of the channel changes;
- Link layer delay - Depending of the spectrum band in use, it is expected different path loss, wireless link error, and interference. All these conditions amount to different link layer packet transmission delay;
- Holding Time - The activities of interferers can affect the channel quality to the network. Holding time refers to the expected time duration that the node can occupy a band before getting interrupted. The lower is the holding time the higher is the frequency of spectrum handoff. Since the spectrum handoff also means wasting time in adjusting the transmission to a new channel, then the system throughput and connectivity are sacrificed in these procedures. So channels with longer holding times are therefore better. Since frequent spectrum handoff can decrease the holding time, previous statistical patterns of handoff should be considered.

The spectrum band is characterized by the channel capacity, which can be derived from the above parameters. The SNR is normally used to perform channel capacity estimation, but since it only considers the observations at the receiver, then the previous parameters need also to be considered to estimate the channel capacity.

### 1.2.3 Spectrum Decision

Upon characterization of the available spectrum bands and the associated potential estimated channel capacity, the appropriate operating spectrum band

can be selected. Based on the CRN node QoS requirements, the data rate, acceptable error rate, delay bound, transmission mode, and bandwidth can be determined. Then according to the decision rule in use, the set of appropriate spectrum bands can then be chosen.

Several examples of rules to be used in the SD function can be found in the literature. Here we briefly highlight some of them. In [41], five SD rules are presented, which are focused on fairness and communication cost, however assuming that all channels have similar throughput capacity. In [17], an opportunistic frequency channel skipping protocol is proposed for the search of channels with better quality, and where the decision is based on the channel SNR. In [4], an adaptive based centralized decision solution is presented, which also considers spectrum sharing. The adaptation mechanism considers the user traffic and the base station's hardware resources.

## 1.2.4 Spectrum Mobility

The purpose of the Spectrum Mobility (SMob) function is to allow a network to use the spectrum in a dynamic manner, i.e. allowing the CR nodes to operate in the best available frequency band. The SMob function is defined as the process through which a CRN node changes its frequency of operation, also known as spectrum handoff, [5].

In a CR network, the SMob arises when the conditions of the channel in use by the node become worse, due to the node movement or because an interferer appears in the channel. The SMob gives rise to a new type of handoff, referred to as spectrum handoff in [5]. A CR can adapt to the frequency of operation. Therefore, each time a CR node changes its frequency of operation, the network protocols are going to shift from one mode of operation to another. The different layers protocols of the network stack need to adapt to the channel transmission parameters of the operating frequency, as well as being transparent to the spectrum handoff and the associated latency.

The purpose of SMob management in CR networks is to make sure that such transitions are made smoothly and as soon as possible such that the applications running on a CRN node perceive minimum performance degradation during a spectrum handoff. It is therefore essential for the mobility management protocols to learn in advance about the duration of a spectrum handoff. This information can be provided by the SS and SA algorithms, through the estimation of the channel holding time. Once the mobility management protocols learn about this latency, their job is to make sure that the

ongoing communications of a CRN node undergo only minimum performance degradation.

Whenever a spectrum handoff occurs, there is an increase in latency, which directly affects the performance of the communication protocols. Thus, the main challenge in SMob is to reduce the latency for spectrum handoff which is associated to the SS latency. During spectrum handoff, the channel parameters such as path loss, interference, wireless link error rate, and link layer delay are influenced by the dynamic use of the spectrum. On the other hand, the changes in the PHY and MAC channel parameters can initiate spectrum handoff. Moreover, the user application may request spectrum handoff to find a better quality spectrum band.

As shown in Figure 1.2, the SMob function cooperates with SD and SA function and SS to decide on an available spectrum band. In order to estimate the effect of the spectrum handoff latency, information about the link layer and sensing delays are required. Moreover, the transport and application layer need to be aware of the latency to reduce the abrupt quality degradation. In addition, the routing information is also important for the route recovery algorithms which base their decisions also on the information estimated about the frequency of spectrum handoff on each of the available links. For these reasons, the SMob is closely related to the operations in all communication layers.

### 1.2.5 Spectrum Sharing

The shared nature of the wireless channel requires the coordination of transmission attempts between CRN nodes. Spectrum Sharing (SSh) can be regarded to be similar to generic MAC problems in traditional systems. However, substantially different challenges exist for SSh in CR networks. The coexistence with other systems and the wide range of available spectrum are the main reasons for these unique challenges.

In [5] it was provided an overview of the steps of SSh in CRN. The SSh process consists of five steps:

- Spectrum sensing - When a CRN node aims to transmit packets, it first needs to be aware of the spectrum usage around its vicinity;



- Spectrum allocation - Based on the spectrum availability, the node can then allocate a channel. This allocation does not only depend on spectrum availability, but it is also determined based on existing spectrum access policies;
- Spectrum Access - Since there may be multiple CRN nodes trying to access the spectrum, this access should be coordinated in order to prevent multiple users colliding in overlapping portions of the spectrum;
- Transmitter-receiver handshake - Once a portion of the spectrum is determined for communication, the receiver should also be informed about the selected spectrum;
- Spectrum Mobility - When the conditions of the allocated spectrum deteriorate, the CRN nodes need to move to another vacant portion of the spectrum, making use of the spectrum mobility function.

The existing work in the literature regarding SSh can be classified in three aspects, being those architecture, spectrum allocation behavior and spectrum access technique.

The classification of spectrum sharing techniques based on the architecture is as follows:

- Centralized - A centralized entity controls the spectrum allocation and access procedures. To aid the procedures, a distributed sensing procedure is proposed such that each entity in the network forwards its measurements about the spectrum allocation to the central entity and this entity then constructs a spectrum allocation map. Examples of this kind of architecture can be found in [7, 30, 38, 32, 4, 31, 33];
- Distributed - Distributed solutions are mainly proposed for cases where the construction of an infrastructure is not preferable. Each node is responsible for the spectrum allocation and access is based on local or global use policies. These policies can be vendor specific or can be dictated by an regulator entity, like the Federal Communications Commission (FCC). An example can be found in [15].

The classification of SSh techniques based on the access behavior is as follows:

- Cooperative - Cooperative solutions consider the effect of the node's communications on other nodes. The interference measurements of each node are shared with other nodes, and the spectrum allocation algorithms

also consider this information. All centralized solutions are regarded as cooperative, although there are also distributed cooperative solutions. Examples of these can be found in [16, 7, 33, 15, 19, 39];

- Non-Cooperative - Non-cooperative solutions consider only the node at hand. These solutions are also referred to as selfish. While non-cooperative solutions may result in reduced spectrum utilization, they do not require the exchange of control information among other nodes as the cooperative ones do. Examples of these can be found in [41, 24, 40].

When comparing these approaches in terms of architecture and access behavior, it was shown in the literature that cooperative approaches outperform non-cooperative ones, moreover it was shown that distributed solutions closely follow centralized solutions. Evidence of these results can be found in [26, 28, 40].

The classification of spectrum sharing techniques based on the access technology is as follows:

- Overlay - In overlay spectrum sharing, a node accesses the network using a portion of the spectrum that is not used by licensed users. As a result, interference to the primary system is minimized, [16, 7, 42, 24, 40, 42, 23, 11];
- Underlay - Underlay spectrum sharing exploits the spread spectrum techniques developed for cellular networks, an example can be found in [15]. Once a spectrum allocation map has been acquired, a CR node transmits in a way such that its transmitting power at a certain portion of the spectrum is regarded as noise by the licensed users. This technique requires sophisticated spread spectrum techniques and can use increased bandwidth when compared to overlay techniques.

The theoretical work on spectrum access in CRN reveals important trade-offs for the design of spectrum access protocols. It was shown that cooperative settings result in higher utilization of the spectrum as well as improved fairness. However, this advantage may eventually not be so high considering the cost of cooperation due to the signaling overhead. In [11, 20] it was shown that the spectrum access technique, i.e. whether it is overlay or underlay, always affects the performance of legacy systems. While an overlay technique focuses on the holes in the spectrum, dynamic spreading techniques are required for underlay techniques for interference free operation between concurrent systems.

The performance of SSh depends on the SS capabilities of the CRN nodes. SS as mentioned before is both a PHY function, when considering the detection, and a MAC function in the case of cooperative detection, since the CRN nodes need to make use of a common channel for exchanging sensing information. Therefore, it is clear that the performance of communication protocols depend on SS, i.e. on getting accurate information about the spectrum utilization at the CRN nodes locations, implying a cross-layer design between SSh and SS.

### **1.2.6 Physical Architecture and Re-configurability**

The CR needs to be implemented on top of a hardware platform which enables its functionality. In Figure 1.5 it is depicted a generic architecture of a CR transceiver, based on the one proposed in [16]. The main components of a CR transceiver are the radio front-end and the baseband processing unit. Each component can be reconfigured via a control bus to adapt to the time-varying Radio Frequency (RF) environment. In the RF front-end, the received signal is amplified, mixed and Analog to Digital (A2D) converted. The baseband processing unit of a CR is essentially similar to existing transceivers. The solution to enable this is the use of SDR platforms, an example of which currently available in the market is the hardware enabling the GNU radio software stack [2, 1].

While the functions mentioned before, i.e. SS, SA and SD, enable the cognitive capability, provide the spectrum awareness, whereas the re-configurability enables the radio to be dynamically programmed according to the radio environment. More specifically, the re-configurability is the capability of adjusting operation parameters for the transmission on-the-fly without any modifications on the hardware components.

This capability enables the CRN node to easily adapt to the dynamic radio environment. In [5] one enunciates what should be the main reconfigurable parameters to be implemented in the CR, being those:

- Operating Frequency - Based on the radio environment information, the most suitable operating frequency can be determined, enabling the communication to be dynamically performed in the appropriate frequency;
- Modulation - A CRN node should reconfigure the modulation scheme in a way that is adaptive to the user requirements and channel conditions, i.e., in the case of delay sensitive applications, the data rate is more important than the error rate. Thus, the modulation scheme that enables

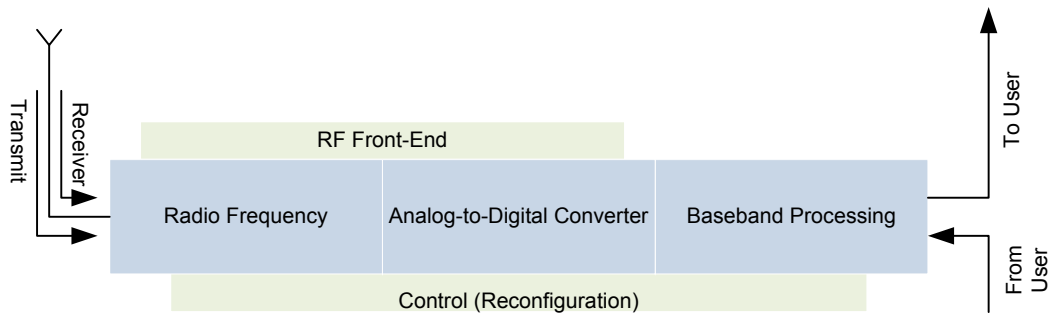

Figure 1.5: Cognitive radio transceiver.

the higher spectral efficiency should be selected. Conversely, the loss-sensitive applications require modulation schemes with low bit error rate;

- **Transmission Power** - Power control enables dynamic transmission power configuration within the permissible power limit. If higher power operation is not necessary, the CR reduces the transmitter power to a level that allows more users to share the spectrum, decreasing the interference;
- **Communication Technology** - A CR can also be used to provide interoperability among different communication systems, therefore employing the SDR capabilities.

The transmission parameters of a CR can be reconfigured not only at the beginning, but also during a transmission. According to the spectrum characteristics, these parameters can be reconfigured such that the CR is switched to a different spectrum band, the transmitter and receiver parameters are reconfigured and the appropriate communication protocol parameters and modulation schemes are used. Such a re-configuration framework has been proposed in [14].

## 1.3 Motivation

The main focus in this thesis is on how to enable CSS in a CRN. The motivation to focus only on this aspect of CR comes from that the SS is the key mechanism to enable spectrum awareness, without which all the other CR functions cannot operate. So as referred before the CR [22, 9] has emerged as a technology which allows the access on the intermittent periods of unoccupied frequency bands, SH, and therefore increasing the spectral efficiency.

To allow this opportunistic access, the CRN nodes must be able to detect the presence of the licensed nodes in a monitored range of spectrum, also known in the literature as Primary User (PU) – which are denoted in this thesis also as the incumbent – and detect when that spectrum is available. This is accomplished by the SS, where the CRN node samples the targeted spectrum and based on those samples decides whether an incumbent signal is present or not. The purpose of SS, besides detecting available resources, is also to limit the interference that the CRN nodes may cause in the incumbent. Therefore the detection performance of the SS scheme in use by the CR nodes is crucial to the performance of both CRN as well as the incumbent network, may it be licensed or not.

The performance of detector used in the spectrum sensing mechanism is given by:

- Probability of False Alarm,  $p_{fa}$  - which quantifies the probability of a CR user declaring that a incumbent is present in the spectrum when the spectrum it is not. The occurrence of a false alarm will reduce the spectral efficiency, since spectrum resources are identified as occupied when they are in fact available to be used;
- Probability of Detection,  $p_d$  - which quantifies the probability of a CR user detecting that a incumbent is present. When a missdetection occurs the CRN node will most likely try to use the identified resource, and therefore the incumbent will be interfered.

The  $p_{fa}$  and  $p_d$  can be expressed as function of the other, and therefore a common practice when designing a detector for optimal detection performance, the  $p_d$  is maximized while subject to the constraint of the  $p_{fa}$ .

The detection performance is affected by the channel conditions, which depend on the path loss, multipath, shadowing, local interference and noise uncertainty [34, 9]. The combination of these phenomena can result in regimes where the SNR at the CRN node is below the detection threshold of the detector, and therefore the incumbent signal will most likely not be detected.

Consider the scenario illustrated in Figure 1.6(a), where there is a primary system and cognitive radio system, both composed by a transmitter and receiver. The CR transmitter is not able to detect the transmission of the primary transmitter, because it is outside the incumbent transmission range, i.e., the SNR is below the CR transmitter detection threshold. So the CR transmitter sees the channel as vacant and therefore decides to transmit on it, causing interference to the incumbent receiver. This is known as the hidden

node problem. So even if a transmission is not detected by the sensing node, it does not mean that there is not one there, namely because the sensing node may be under a deep fade, due to an obstacle in the terrain.

To overcome these limitations, in [8, 12, 21, 37, 9] it was proposed the use of cooperation in the SS. Since the signal strength varies with the LD location, the worst fading conditions can be avoided if multiple sensors in different spatial locations share their sensing measurements, i.e., take advantage of the spatial diversity, therefore improving the overall detection performance.

The main idea behind the CSS is to enhance the detection performance by exploiting the spatial diversity in the observations of spatially located CRN nodes. Through this cooperation the CRN nodes can share their individual sensing information and then combine them to achieve a more accurate decision than the ones possible when only the individual sensing information is available.

From the wireless receiver perspective, the multipath fading and shadowing make the SNR of the received incumbent signal to be small, beyond the capabilities of the receiver to detect, since it might be below the receiver sensitivity. The receiver sensitivity is the capability of the receiver to detect weak signals, and higher is the sensitivity – the lower detectable SNR – the higher is the hardware complexity and therefore associated cost. Also below a certain SNR threshold it is not possible to detect the signal, even by increasing the receiver sensitivity, since there is a limit caused by the noise uncertainty, known as the SNR wall [34]. Through the use of cooperation it is possible relieve the receiver sensitivity requirements and ensure that it is above the SNR wall, as illustrated in Figure 1.7 [21], and make it approximately set to the same level as the nominal path loss [21], being this called the potential cooperative gain.

It should be noted that this potential cooperative gain is not limited to improving the detection performance and to relax the sensitivity requirement. It can also be used in other areas such to reduce the sensing time, i.e. reduce the number of samples needed for the SS and therefore increase the SS efficiency, since it leaves the CRN node more time for data transmission and consequentially increasing the CRN node throughput.

The potential cooperative gain might not be achievable due to other limiting factors, such as if the CR nodes are behind the same obstacle their channel conditions are correlated and therefore this will affect the detection performance [12, 21]. So to achieve the potential gain it is necessary to have a node selection mechanism in the CSS so to ensure that the collaborating CRN nodes are not too correlated to the point of affecting the detection performance.

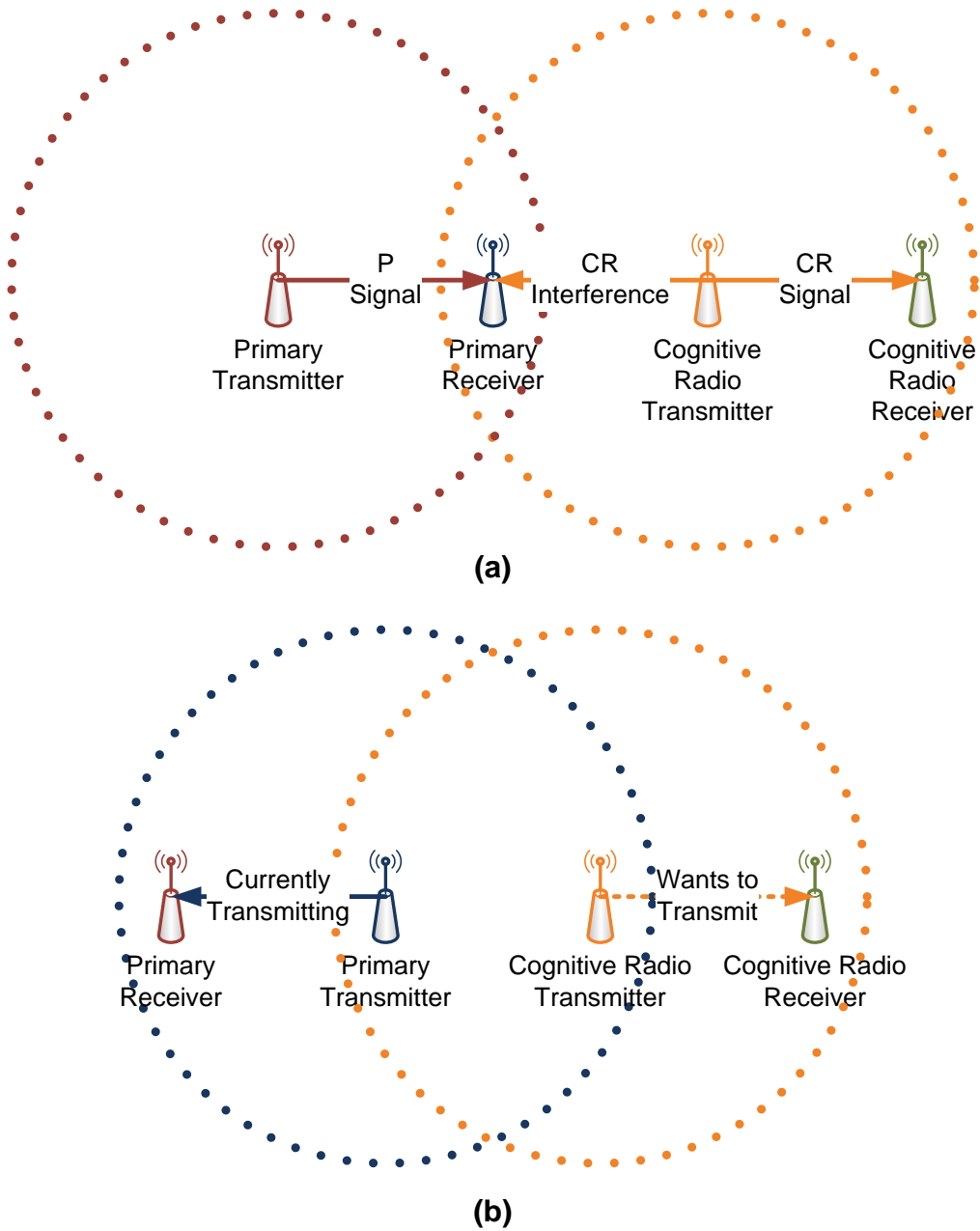

Figure 1.6: (a) Hidden Node Problem, (b) Exposed Node Problem

The use of CSS schemes also brings drawbacks to the CRN, known as cooperation overhead. This overhead refers to any extra effort that the CRN node needs to do to accomplish CSS when compared to the case where no CSS is done. This extra effort can be extra sensing time, delay, extra spent energy

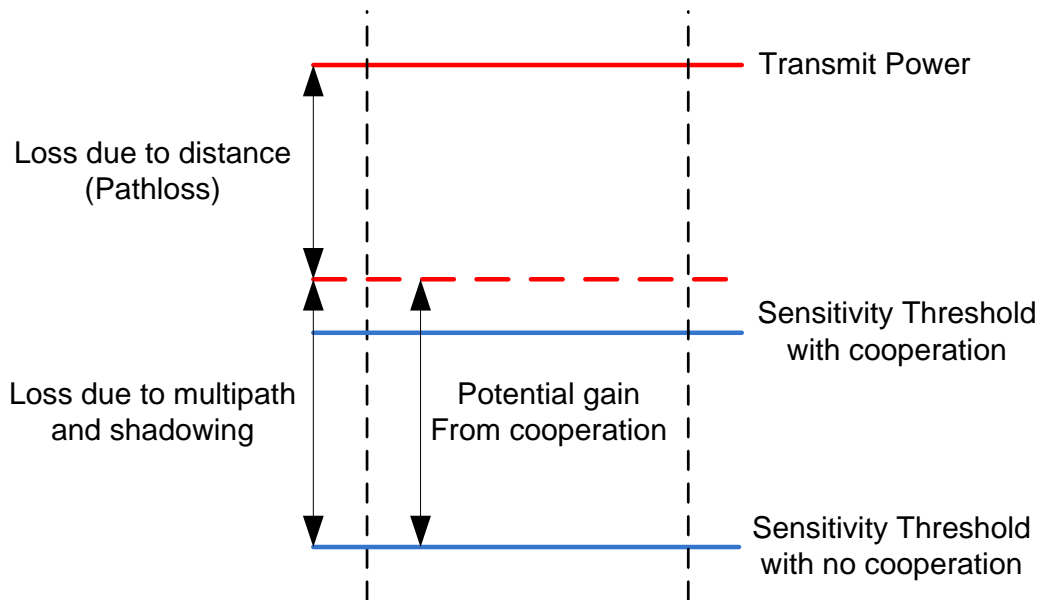

Figure 1.7: Receiver sensitivity

and other operations devoted to accomplish the CSS. Also any performance degradation due to imperfect CR node selection, where the nodes are under correlated shadowing, or vulnerability to security attacks.

Another cooperative overhead not considered in the literature [6, 27] is that although it might be problematic to choose CR nodes which are under correlated shadowing, when opposed to the case where the nodes are experiencing completely uncorrelated conditions, there is also a drawback for not doing so. Consider the scenario illustrated in Figure 1.6(b), where there is a primary system and cognitive radio system, both composed by a transmitter and receiver. Both the CRN node and the primary transmitters are able to detect each other, but the receivers are outside the interference zone, i.e., the CRN receiver is outside the range of the primary transmitter, and the primary receiver outside the range of the CRN transmitter, so if both transmitters would do a transmission there would be no interference, but since the transmitters detect each other then only one of them transmits at a given time. This is known as the exposed node problem.

The effect of the exposed node problem is increased by fusing together sensing results taken from spatial positions apart, and therefore by combining sensing results from positions far apart, one is losing the information about possible available spectrum opportunities, i.e. losing information about the



spatial diversity. This phenomenon is illustrated in Figure 1.8, where the colored regions represent where the spectrum is available and non-colored where the spectrum is occupied. After the Data Fusion (DF) occurs the information about the regions where the spectrum was available disappears, therefore causing the network to lose that information.

So the above gives the motivation for the development of a CSS mechanism, where each of its composing elements need to be taken into account so that then resulting mechanism increases the network performance instead of the opposite.

## **1.4 Problem Definition**

The problem tackled in this thesis was on how to develop a CSS mechanism which both overcomes the hidden node problem, does not accentuate the exposed node problem and at the same time is efficient and allows to monitor several frequency channels. With that in mind the problem tackled can be expressed through the following questions:

- What are the essential components of a CSS mechanism?
- What are the properties that a protocol should have to enable this CSS mechanism?
- How should the CRN nodes cooperate?
- If the local decisions of the CRN nodes are to be combined, where should it be done and how?
- What is the effect of correlation in regards to the combining of the local decisions of the CRN nodes?
- How to select which CRN nodes should sense which channel in a multi-channel context?

In this thesis each one of this questions is analyzed and answered.

## **1.5 Original Contributions and Publications**

The original contributions given throughout this thesis are the following:

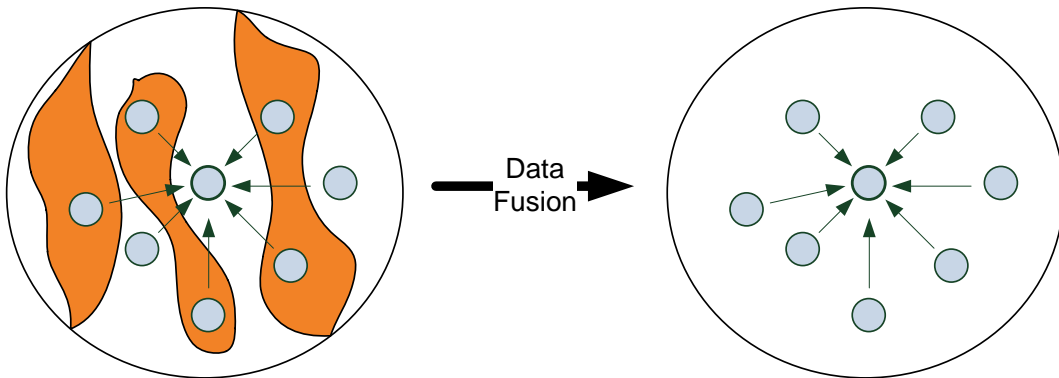

Figure 1.8: The drawback of using data fusion, the loss of spatial diversity

- A distributed protocol which enables the Cooperative Spectrums Sensing is proposed over three different network topologies, a centralized, a decentralized and a relay aided one;
- A process calculus, denoted as Bounded Broadcast Calculus, which is used to model and prove the correctness of the proposed distributed protocols that enable the Cooperative Spectrum Sensing;
- An adaptive counting rule for the data fusion of the local decisions, which is able to select the best  $k$ -threshold based on the performance of the local detectors and the incumbent signal duty cycle;
- A methodology to measure the potential resources that a cooperative spectrum sensing mechanism can identify;
- A cluster based adaptive counting rule algorithm, which groups together the local detectors that are experiencing the same conditions. Through this algorithm is possible to maximize the amount of potential resources identified;
- A centralized and a decentralized Node Selection mechanism, which the goal is to maximize the amount of potential resources identified in a multi-channel scenario.

The publications performed during the Ph.D. work which are directly related to the work described in this thesis are listed below.

The conference publications are the following:

- a - Nuno Pratas, Neeli Rashmi Prasad, António Rodrigues and Ramjee Prasad, *Cooperative spectrum sensing: State of the art review*, Wireless

Communication Society, Vehicular Technology, Information Theory and Aerospace and Electronic Systems Technology, Wireless VITAE 2011;

- b - Nuno Pratas, Nicola Marchetti, António Rodrigues, Neeli Rashmi Prasad and Ramjee Prasad, *Adaptive Counting Rule for Cooperative Spectrum Sensing Under Correlated Environments*. The 13th International Symposium on Wireless Personal Multimedia Communications (WPMC 2010); **Best Student Paper Award**
- c - Nuno Pratas, Nicola Marchetti, António Rodrigues and Ramjee Prasad, *Capacity Limits Introduced by Data Fusion on Cooperative Spectrum Sensing under Correlated Environments*. The 8th Communications International Conference, in Bucharest, Romania. COMM 2010; **Best Student Paper Award**
- d - Nuno Pratas, Nicola Marchetti, Neeli Rashmi Prasad, António Rodrigues and Ramjee Prasad, *Centralized Cooperative Spectrum Sensing for Ad-hoc Disaster Relief Network Clusters*. IEEE International Communications Conference, IEEE ICC 2010;
- e - Nuno Pratas, Nicola Marchetti, Neeli Rashmi Prasad, António Rodrigues and Ramjee Prasad, *Decentralized Cooperative Spectrum Sensing for Ad-hoc Disaster Relief Network Clusters*. 2010 IEEE 71st Vehicular Technology Conference: VTC2010-Spring, IEEE VTC2010-Spring;

The journal publications are the following:

- f - Nuno Pratas, Nicola Marchetti, Neeli Rashmi Prasad, António Rodrigues and Ramjee Prasad, *System Capacity Limits Introduced by Data Fusion on Cooperative Spectrum Sensing under Correlated Environments*, MTA Review XX(4), 245-262 (2010), Romania;
- g - Nuno Pratas, Nicola Marchetti, Neeli Rashmi Prasad, António Rodrigues and Ramjee Prasad, *Adaptive Counting Rule for Cooperative Spectrum Sensing Under Correlated Environments*, Special Issue of the Wireless Personal Communications Journal from Springer Verlag;
- h - Nuno Pratas, Hans Hüttel, *Understanding Cooperative Spectrum Sensing using a Process Calculus*; (submitted)

The book chapter:

i - Nuno Pratas, Nicola Marchetti, Neeli Rashmi Prasad, António Rodrigues and Ramjee Prasad, *Cognitive Disaster Relief Networks*, in *Telecommunications in Disaster Areas*, ISBN : 978-87-92329-48-6. River Publishers

Other publications done in parallel not directly related with the work presented in this thesis but which had an effect on the methodology followed are the following: The conference publications are the following:

- Nuno Pratas, Filippo Meucci, Damir Zrno, Neeli Rashmi Prasad, António Rodrigues and Ramjee Prasad, *Cogito Test-bed - Cognitive Research Evolved*, Wireless Communication Society, Vehicular Technology, Information Theory and Aerospace and Electronic Systems Technology, Wireless VITAE;
- Nuno Pratas, P.N. Anggraeni, S.A. Wardana, Neeli Rashmi Prasad, António Rodrigues and Ramjee Prasad, *Context-Aware Trust and Privacy Application for Mobile Identification System*, Wireless Communications and Networking Conference 2009, WCNC 2009;
- João Mestre, Nuno Pratas, Neeli Rashmi Prasad, António Rodrigues and Ramjee Prasad, *Adaptive Flexible Spectrum Usage Algorithms in Heterogeneous Cell Deployment*. PIRMC 2011
- Andrei Lucian Stefan, Cyril Rota, Juras Klimasauskas, Nuno Pratas, Neeli Rashmi Prasad and Ramjee Prasad, *Spectrum and Service pricing for 802.22 networks*. The 14th International Symposium on Wireless Personal Multimedia Communications: WPMC 2011
- Pedro Alvarez, Nuno Pratas, Neeli Rashmi Prasad, António Rodrigues and Ramjee Prasad, *Energy Detection and Eigenvalue Based Detection: An Experimental Study Using GNU Radio*. The 14th International Symposium on Wireless Personal Multimedia Communications: WPMC 2011
- Frederico Santos, Nuno Pratas, Neeli Rashmi Prasad and António Rodrigues, *Multimedia Broadcast Multicast System Enhancements - The Layer Algorithm*. The 13th International Symposium on Wireless Personal Multimedia Communications: WPMC 2010

The journal publications are the following:

- Nuno Pais, Bilge Kartal, Nuno Pratas, Neeli Rashmi Prasad, Fernando Velez and Ramjee Prasad, *Cost-benefit Aware Routing Protocol for Wireless Sensor Networks with Hybrid Energy Storage System*. Green Engineering Journal

## 1.6 Thesis Outline

The outline of the thesis is given in Figure 1.9, which depicts the a generalized CSS mechanism proposed in this thesis, as well where each of the contributions fit.

In Chapter 1 was given an overview on the Cognitive Radio fundamentals and its functionality, together with the motivation for the work developed and described in this thesis, the problem definition and the original contributions.

In Chapter 2 is discussed the Cooperative Spectrum Sensing state of the art. Where it is highlighted the most common spectrum sensing methods, how the local decisions of the local detectors are reported to the network, how the local decisions can be combined to achieve a network wide decisions in regards to the monitored spectrum, how this information can be constructed over time, and finally an overview of the node selection methods available is given.

In Chapter 3 is presented an analysis of the correctness of the protocol which enable the CSS. This is done by proposing and employing a process calculus which is a variant of the  $\pi$ -calculus, denoted as Bounded Broadcast Calculus (BBC). This analysis is done over centralized, decentralized and relay aided topologies. The outcome of this chapter is a theorem which states the formal correctness properties of a protocol for each of the network topologies considered.

Chapter 4 presents an analysis of the performance of the counting rule based data fusion schemes. It is also proposed an adaptive counting rule algorithm which adapts the decision threshold according to the performance of the local detectors. In this chapter is also done a study about the impact of using local detectors in the data fusion scheme which are experiencing different channel conditions, i.e. some of these local detectors are experiencing the channel as free while other as occupied. In this analysis is measured what is the impact of using data fusion regarding these cases, whether it improves the detection of these available resources, minimizing both the hidden and exposed node problem. The chapter concludes with the proposal and the analysis of the performance of a cluster based adaptive counting rule data fusion scheme.

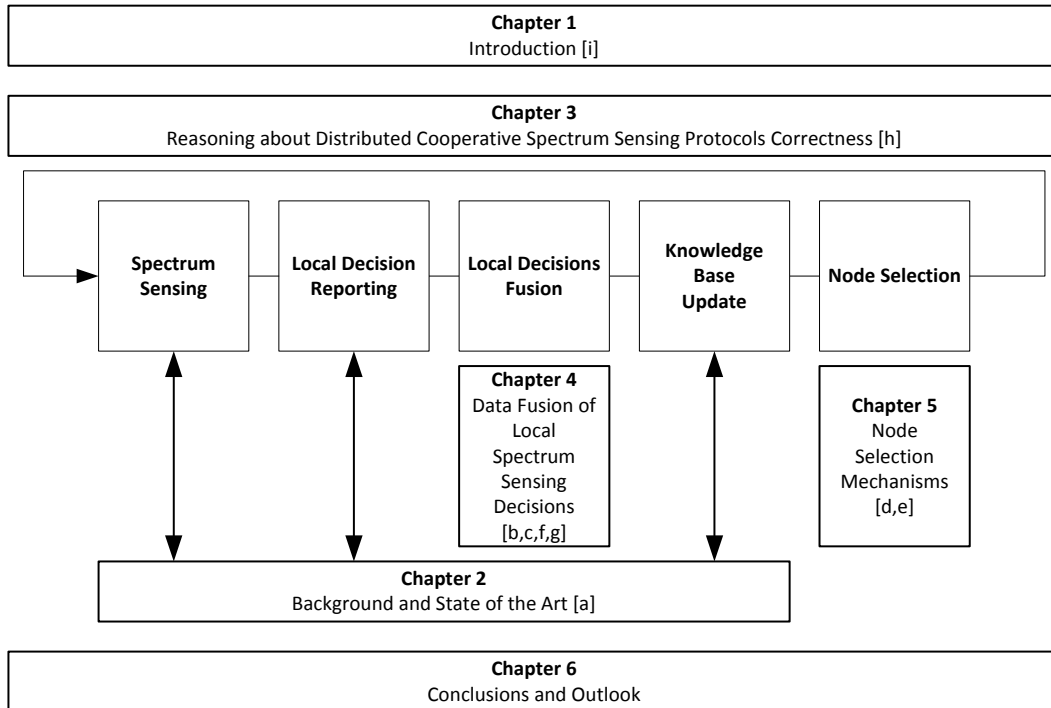

Figure 1.9: Thesis Outline

Chapter 5 presents the framework for a Node Selection (NS) mechanism which allows to select which local detectors are sensing which channel at a given sensing session. Two algorithms, a centralized and a decentralized, are proposed to implement the proposed NS mechanism. The purpose of using such scheme is to ensure that the correct amount of the local detectors is sensing each channel, and therefore maximize the amount of channels sensed. The proposed scheme tends to assign the local detectors to channels which have an higher probability of being available, so to increase the probability of the network finding a channel which is available to be used.

Finally in Chapter 6 the final conclusions and outlook for future work are given.

## References

- [1] Ettus research. <http://www.ettus.com/>.
- [2] Gnu radio. <http://gnuradio.org/>.

- [3] Et docket no 03-222 notice of proposed rulemaking and order. Technical report, FCC, December 2003.
- [4] K. Akabane, H. Shiba, M. Matsui, and K. Uehara. An autonomous adaptive base station that supports multiple wireless network systems. In *2nd IEEE International Symposium on New Frontiers in Dynamic Spectrum Access Networks, 2007. (DySPAN 2007)*, pages 85–88, April 2007.
- [5] Ian F. Akyildiz, Won-Yeol Lee, Mehmet C. Vuran, and Shantidev Mohanty. Next generation/dynamic spectrum access/cognitive radio wireless networks: a survey. *Computer Networks*, 50(13):2127–2159, 2006.
- [6] Ian F. Akyildiz, Brandon F. Lo, and Ravikumar Balakrishnan. Cooperative spectrum sensing in cognitive radio networks: A survey. *Physical Communication*, 4(1):40–62, 2011.
- [7] V. Brik, E. Rozner, S. Banerjee, and P. Bahl. Dsap: a protocol for coordinated spectrum access. In *First IEEE International Symposium on New Frontiers in Dynamic Spectrum Access Networks, 2005. (DySPAN 2005)*, pages 611–614, November 2005.
- [8] D. Cabric, A. Tkachenko, and R. W. Brodersen. Experimental study of spectrum sensing based on energy detection and network cooperation. In *Proceedings of the first international workshop on Technology and policy for accessing spectrum, TAPAS '06*, New York, NY, USA, 2006. ACM.
- [9] K.C. Chen and R. Prasad. *Cognitive Radio Networks*. John Wiley and Sons Ltd, April 2009.
- [10] C. Cordeiro, K. Challapali, D. Birru, and N. Sai Shankar. Ieee 802.22: the first worldwide wireless standard based on cognitive radios. In *First IEEE International Symposium on New Frontiers in Dynamic Spectrum Access Networks, 2005. (DySPAN 2005)*, pages 328–337, November 2005.
- [11] R. Etkin, A. Parekh, and D. Tse. Spectrum sharing for unlicensed bands. *IEEE Journal on Selected Areas in Communications*, 25(3):517–528, April 2007.
- [12] A. Ghasemi and E.S. Sousa. Collaborative spectrum sensing for opportunistic access in fading environments. In *First IEEE International Symposium on New Frontiers in Dynamic Spectrum Access Networks, 2005. (DySPAN 2005)*, pages 131–136, November 2005.

- [13] S. Haykin. Cognitive radio: brain-empowered wireless communications. *IEEE Journal on Selected Areas in Communications*, 23(2):201–220, February 2005.
- [14] O. Holland, M. Muck, P. Martigne, D. Bourse, P. Cordier, S. Ben Jemaa, P. Houze, D. Grandblaise, C. Klock, T. Renk, Jianming Pan, P. Slanina, K. Mobner, L. Giupponi, J.P. Romero, R. Agusti, A. Attar, and A.H. Aghvami. Development of a radio enabler for reconfiguration management within the ieeep1900.4 working group. In *2nd IEEE International Symposium on New Frontiers in Dynamic Spectrum Access Networks, 2007. (DySPAN 2007)*, pages 232–239, April 2007.
- [15] J. Huang, R.A. Berry, and M.L. Honig. Spectrum sharing with distributed interference compensation. In *First IEEE International Symposium on New Frontiers in Dynamic Spectrum Access Networks, 2005. (DySPAN 2005)*, pages 88–93, November 2005.
- [16] F.K. Jondral. Cognitive radio: A communications engineering view. *IEEE Wireless Communications*, 14(4):28–33, August 2007.
- [17] V. Kanodia, A. Sabharwal, and E. Knightly. Moar: a multi-channel opportunistic auto-rate media access protocol for ad hoc networks. In *Proceedings First International Conference on Broadband Networks, 2004. (BroadNets 2004)*, pages 600–610, October 2004.
- [18] H. Kim and K.G. Shin. Efficient discovery of spectrum opportunities with mac-layer sensing in cognitive radio networks. *IEEE Transactions on Mobile Computing*, 7(5):533–545, May 2008.
- [19] L. Ma, X. Han, and C.-C. Shen. Dynamic open spectrum sharing mac protocol for wireless ad hoc networks. In *First IEEE International Symposium on New Frontiers in Dynamic Spectrum Access Networks, 2005. (DySPAN 2005)*, pages 203–213, nov. 2005.
- [20] Rekha Menon, R.M. Buehrer, and J.H. Reed. Outage probability based comparison of underlay and overlay spectrum sharing techniques. In *First IEEE International Symposium on New Frontiers in Dynamic Spectrum Access Networks, 2005. (DySPAN 2005)*, pages 101–109, nov. 2005.
- [21] S.M. Mishra, A. Sahai, and R.W. Brodersen. Cooperative sensing among cognitive radios. In *IEEE International Conference on Communications, 2006. (ICC 2006)*, volume 4, pages 1658–1663, 2006.



## REFERENCES

---

- [22] III Mitola, J. and Jr. Maguire, G.Q. Cognitive radio: making software radios more personal. *IEEE Personal Communications*, 6(4):13–18, aug. 1999.
- [23] N. Nie and C. Comaniciu. Adaptive channel allocation spectrum etiquette for cognitive radio networks. In *First IEEE International Symposium on New Frontiers in Dynamic Spectrum Access Networks, 2005. (DySPAN 2005)*, pages 269–278, November 2005.
- [24] P. Papadimitratos, S. Sankaranarayanan, and A. Mishra. A bandwidth sharing approach to improve licensed spectrum utilization. *IEEE Communications Magazine*, 43(12):supl.10 – supl.14, December 2005.
- [25] R.V. Prasad, P. Pawelczak, J.A. Hoffmeyer, and H.S. Berger. Cognitive functionality in next generation wireless networks: standardization efforts. *IEEE Communications Magazine*, 46(4):72–78, April 2008.
- [26] N. Pratas, N. Marchetti, N. R. Prasad, A. Rodrigues, and R. Prasad. Decentralized cooperative spectrum sensing for ad-hoc disaster relief network clusters. In *IEEE 71st Vehicular Technology Conference (VTC 2010-Spring)*, pages 1–5, May 2010.
- [27] N. Pratas, N. Marchetti, N. R. Prasad, A. Rodrigues, and R. Prasad. System capacity limits introduced by data fusion on cooperative spectrum sensing under correlated environments. *MTA Review*, XX(4):245–262, 2010.
- [28] N. Pratas, N. Marchetti, N.R. Prasad, A. Rodrigues, and R. Prasad. Centralized cooperative spectrum sensing for ad-hoc disaster relief network clusters. In *IEEE International Conference on Communications (ICC 2010)*, pages 1–5, May 2010.
- [29] Zhi Quan, Shuguang Cui, H.V. Poor, and A. Sayed. Collaborative wide-band sensing for cognitive radios. *IEEE Signal Processing Magazine*, 25(6):60–73, November 2008.
- [30] C. Raman, R.D. Yates, and N.B. Mandayam. Scheduling variable rate links via a spectrum server. In *First IEEE International Symposium on New Frontiers in Dynamic Spectrum Access Networks, 2005. (DySPAN 2005)*, pages 110–118, November 2005.

- [31] H. Singh Mehta and S.A. Zekavat. Dynamic resource allocation via clustered mc-cdma in multi-service ad-hoc networks: Achieving low interference temperature. In *2nd IEEE International Symposium on New Frontiers in Dynamic Spectrum Access Networks, 2007. (DySPAN 2007)*, pages 266–269, April 2007.
- [32] J.A. Stine. A location-based method for specifying rf spectrum rights. In *2nd IEEE International Symposium on New Frontiers in Dynamic Spectrum Access Networks, 2007. (DySPAN 2007)*, pages 34–45, April 2007.
- [33] A.P. Subramanian and H. Gupta. Fast spectrum allocation in coordinated dynamic spectrum access based cellular networks. In *2nd IEEE International Symposium on New Frontiers in Dynamic Spectrum Access Networks, 2007. (DySPAN 2007)*, pages 320–330, April 2007.
- [34] R. Tandra and A. Sahai. Snr walls for signal detection. *IEEE Journal of Selected Topics in Signal Processing*, 2(1):4–17, February 2008.
- [35] H. Urkowitz. Energy detection of unknown deterministic signals. *Proceedings of the IEEE*, 55(4):523–531, April 1967.
- [36] Pramod K. Varshney. *Distributed Detection and Data Fusion*. Springer-Verlag New York, Inc., Secaucus, NJ, USA, 1st edition, 1996.
- [37] E. Visotsky, S. Kuffner, and R. Peterson. On collaborative detection of tv transmissions in support of dynamic spectrum sharing. In *First IEEE International Symposium on New Frontiers in Dynamic Spectrum Access Networks, 2005. (DySPAN 2005)*, pages 338–345, Nov. 2005.
- [38] S.A. Zekavat and X. Li. User-central wireless system: ultimate dynamic channel allocation. In *First IEEE International Symposium on New Frontiers in Dynamic Spectrum Access Networks, 2005. (DySPAN 2005)*, pages 82–87, nov. 2005.
- [39] Jun Zhao, Haito Zheng, and Guang-Hua Yang. Distributed coordination in dynamic spectrum allocation networks. In *First IEEE International Symposium on New Frontiers in Dynamic Spectrum Access Networks, 2005. (DySPAN 2005)*, pages 259–268, November 2005.
- [40] Q. Zhao, L. Tong, and A. Swami. Decentralized cognitive mac for dynamic spectrum access. In *First IEEE International Symposium on New Frontiers in Dynamic Spectrum Access Networks, 2005. (DySPAN 2005)*, pages 224–232, November 2005.

## REFERENCES

---

- [41] H. Zheng and Lili Cao. Device-centric spectrum management. In *First IEEE International Symposium on New Frontiers in Dynamic Spectrum Access Networks, 2005. (DySPAN 2005)*, pages 56 –65, November 2005.
- [42] Haitao Zheng and Chunyi Peng. Collaboration and fairness in opportunistic spectrum access. In *IEEE International Conference on Communications, 2005. (ICC 2005)*, volume 5, pages 3132 – 3136 Vol. 5, May 2005.

# 2

## State of the Art

### 2.1 Introduction

Cooperative Spectrum Sensing can be achieved through different approaches. The dominant approach is to follow the parallel data fusion model [38], although some other approaches have been proposed which follow a sequential data fusion model [19]. It has been also proposed in the literature to resort to the active probing of the primary network [11], where the Cognitive Radio Network (CRN) creates interference on purpose to the primary network to measure its reaction. For this kind of scheme to work the primary network needs to have an Adaptive Modulation and Coding mechanism in place. In this thesis it is considered the more traditional Cooperative Spectrum Sensing (CSS), i.e. passive sensing, using a parallel data fusion model.

To describe how a CSS mechanism can be implemented, consider the generalized model depicted in Figure 2.1. The purpose of this mechanism is to ensure that all the nodes in the CRN have updated and synchronized information about the state of the targeted spectrum. The considered mechanism is the backbone for the centralized [30] and decentralized [28] mechanism implementation, and the interactions between each of the modules, i.e. the protocol, is analyzed in Chapter 3. The modules depicted in the generalized distributed CSS model are elaborated in next sections.

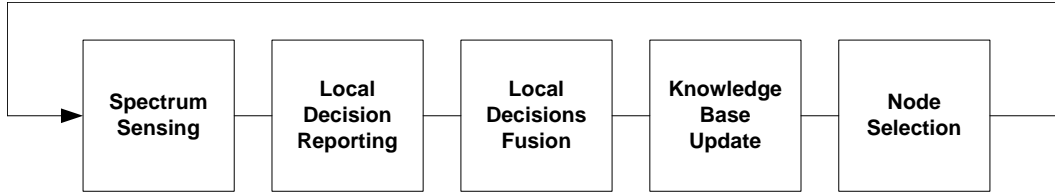

Figure 2.1: Distributed spectrum sensing mechanism flow

## 2.2 Spectrum Sensing

For the CSS mechanism to work it is necessary that a local spectrum sensing detector is available at each of the CRN nodes. The role of Spectrum Sensing (SS) is to detect whether a signal is present or not in the monitored spectrum band. In the literature [21, 3] several SS techniques can be found, in Table 2.1 are listed some of them.

These SS techniques can be classified by whether the detection is coherent or non-coherent and in regards to the monitored spectrum bandwidth, i.e. whether is narrowband or wideband. In the coherent detection, the detection is performed by comparing the received signal or some of its characteristics with a priori knowledge about that specific signal. While in the non-coherent detection a priori knowledge is not required.

Whether for the detection of temporal or spatial Spectrum Hole (SH), SS in CRN involves deciding whether a primary signal is present or not in a spectrum band at the position of the detector, therefore the detection can be formulated as a test of two hypothesis, given by:

$$y(t) = \begin{cases} w(t) & \text{if } H_0 \\ s(t) + w(t) & \text{if } H_1 \end{cases} \quad (2.1)$$

where  $y(t)$  is the received signal at the detector,  $s(t)$  is the signal or in the case there are several signals the summation of those signals, and  $w(t)$  is the additive white gaussian noise.  $H_0$  and  $H_1$  denotes the hypothesis corresponding to the absence and presence of a signal. The detector then decides between  $H_0$  and  $H_1$  from the observation of  $y(t)$ .

For the remaining of the thesis the Energy Detector (ED) [37] is considered as the local detector put in place at the CRN nodes, and therefore a short introduction to its theoretical model is given next.

The ED is the simplest SS technique. The ED can be implemented following the blocks depicted in Figure 2.2, where Figure 2.2(a) is the traditional implementation, while Figure 2.2(b) is an alternative approach proposed in [8, 4]

Table 2.1: Spectrum sensing method overview.

Detector	Coherent	Non-Coherent	Narrowband	Wideband	References
Energy		•	•	•	[37, 12, 8, 32]
Cyclostationary Feature	•		•		[7, 15, 14, 20, 18]
Matched Filter	•		•		[9, 7, 6, 18]
Wavelet		•		•	[6, 35, 18]
Eigenvalue		•	•	•	[40, 41, 26, 18]
Compressed Sensing		•		•	[13, 10, 34]

which allows the detection of narrowband signals and sinewaves with better performance than the traditional implementation.

The ED treats the signal as noise and decides on the presence or absence of the primary signal based on the energy of the observed signal. Since it does not need any a priori knowledge of the signal, the ED is robust to the variation of the signal, does not involve signal processing and has low complexity.

The test statistics,  $T$ , of the ED is obtained as the observed energy summation within  $N$  consecutive samples, i.e.,

$$T = \begin{cases} \sum_{n=1}^N |W(n)|^2 & \text{if } H_0 \\ \sum_{n=1}^N |S(n) + W(n)|^2 & \text{if } H_1 \end{cases} \quad (2.2)$$

where  $S(n)$  and  $W(n)$  denote the spectral components of the received signal and the noise on the channel of interest in the  $n^{\text{th}}$  sample, respectively. The noise is assumed to be additive, white and Gaussian noise with zero mean and variance  $\sigma_w^2$ . Since the detection is non-coherent [8] the signal samples can also be modelled as a Gaussian random process with variance  $\sigma_x^2$ . The decision statistic is an application of the Cell Averaging Constant False Alarm Rate detector [38] for the ED.

Considering the Neyman-Pearson Criterion (NPC), a common detection performance criteria used for weak signal detection [38], the likelihood ratio yields the optimal hypothesis testing solution and performance is measured by probability of detection  $p_d$  and probability of false alarm  $p_{fa}$ .

The probability of detection is defined as,

$$p_d = P(H_1|H_1) \quad (2.3)$$

The probability of false alarm can be defined as,

$$p_{fa} = P(H_1|H_0) = 1 - P(H_0|H_0) \quad (2.4)$$

When the signal is absent, the decision statistic has a central chi-square distribution with  $N$  degrees of freedom. When the signal is present, the decision statistic has a non-central chi square distribution with the same number

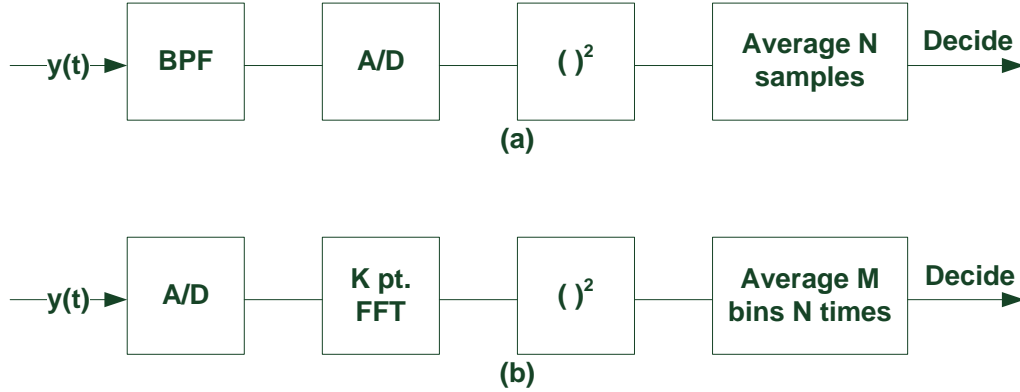

Figure 2.2: Energy Detector Implementation a) with analog pre-filter and square-law device b) implementation using periodogram: FFT magnitude squared and averaging

of degrees of freedom [8]. Considering the purpose is the detection of signals in low Signal to Noise Ratio (SNR) regime, therefore the number of samples required is potentially large. Considering that the number of samples is  $N > 250$  and using the central limit theorem, then it is possible to approximate the test statistics as Gaussian, which yields,

$$T \approx \begin{cases} Normal(N\sigma_w^2, 2N\sigma_w^4) & \text{if } H_0 \\ Normal(N(\sigma_w^2 + \sigma_x^2), 2N(\sigma_w^2 + \sigma_x^2)^2) & \text{if } H_1 \end{cases} \quad (2.5)$$

Therefore,  $p_d$  can be evaluated as,

$$p_d = Q\left(\frac{\gamma - N(\sigma_w^2 + \sigma_x^2)}{\sqrt{2N(\sigma_w^2 + \sigma_x^2)^2}}\right) \quad (2.6)$$

and  $p_{fa}$  as,

$$p_{fa} = Q\left(\frac{\gamma - N\sigma_w^2}{\sqrt{2N\sigma_w^4}}\right) \quad (2.7)$$

Since the Cell Averaging Constant False Alarm Rate is considered, then the threshold  $\gamma$  can be set without the knowledge of the signal power [8]. By manipulating Eq. 2.7, the threshold  $\gamma$  can be expressed as,

$$\gamma = \sigma_w^2 \left[ Q^{-1}(p_{fa}) \sqrt{2N} + N \right] \quad (2.8)$$

Expressing the  $SNR$  as,

$$SNR = \frac{\sigma_x^2}{\sigma_w^2} \quad (2.9)$$

The  $p_d$  can be expressed in function of the  $N$ ,  $SNR$  and  $p_{fa}$ , by combining in Eq. 2.6 both Eq. 2.8 and Eq. 2.9, obtaining the following,

$$p_d = Q \left( \frac{Q^{-1}(p_{fa}) \sqrt{2N} - NSNR}{\sqrt{2N}(1 + SNR)} \right) \quad (2.10)$$

From this equation it is possible to obtain the Receiver Operating Characteristic (ROC) for the pair  $(p_d, p_{fa})$ , while considering a fixed number of samples  $N$  and for a given  $SNR$ . Note that if the number of samples is not limited, then any pair of  $(p_d, p_{fa})$  is possible. The minimum number of samples,  $N_{min}$ , for a given  $(p_d, p_{fa})$  pair and  $SNR$  can be written as,

$$N_{min} = \max \left( 2 \left[ (Q^{-1}(p_{fa}) - Q^{-1}(p_d)) SNR^{-1} - Q^{-1}(p_d) \right]^2, 250 \right) \quad (2.11)$$

The minimum value that  $N$  can take is 250 due to the assumptions taken to define Eq. 2.5. The low  $SNR$  regime ( $SNR \ll 1$ ), according to Eq. 2.11 [8] the number of samples required, for a specified  $(p_d, p_{fa})$  pair, scales as,

$$N_{min} \xrightarrow{SNR \ll 1} O \left( \frac{1}{SNR^2} \right) \quad (2.12)$$

This means, the lower is the  $SNR$  the higher is the sensing time required. Although, according to [33], there is a lower threshold for the SNR, denoted as  $SNR_{wall}$  for which below it is not possible to detect the signal and consequently Eq. 2.11 does not hold. This limitation is due to the signal model used to design the detector [8], where two fundamental assumptions were made:

- Noise Type - the noise was assumed to be white, additive and Gaussian, with zero mean and known variance. However, noise is an aggregation of various sources, such as thermal noise at the receiver and underlined circuits and also interference due to nearby unwanted emissions, weak signals from far way, etc;
- Noise Variance - the noise variance was assumed to be known to the receiver, so that that threshold could be set accordingly. However this is not realistic since the noise could vary over time due to temperature



change, ambient interference, filtering, etc. Even considering that the receiver estimates it, there is a resulting estimation error due to limited amount of observation time.

Therefore, the detection model needs to account the measure of noise variance uncertainty. In [33], this  $SNR_{wall}$  was defined as,

$$SNR_{wall} = 10 \log_{10} (10^{\frac{x}{10}} - 1) \quad (2.13)$$

where  $x$  is the noise uncertainty threshold. So if the threshold is set too high, due to wrong estimated noise variance, then signals below the  $SNR_{wall}$  cannot be detected.

## 2.3 Local Decision Reporting

After the SS is performed and a local decision is achieved, then it is time to report that same decision to the network. The destination of the reporting will depend on the CSS topology that the network has in place. The cooperation in the network can be organized in one of three topologies, a centralized, a decentralized or relay based one, all depicted in Figure 2.3.

In the centralized network topology the network is composed by a central node, Central Node (CN), and one or several sensing nodes, Sensing Node (SN), as depicted in Figure 2.3(a). In this kind of topology the CN is the one responsible for selecting which nodes will sense the spectrum and also responsible for computing the cooperative decisions based on the local decisions from each of the sensing nodes. The drawback of this topology is that if the CN drops from the network then the CSS mechanism stops until the CN is restored or until a new CN is selected or set-up.

In the decentralized network topology the network is composed only by sensing nodes, SN, as depicted in Figure 2.3(b). In this topology the Sensing Nodes (SNs) exchange the local decisions between each other with the purpose of either reaching a unified decision or to improve the own local decision of the SNs. In the later case a unified decision may not be reached since not all SNs will have access to the same sensing data, since not all SNs might be in each other reach. A possible way of overcoming this is to allow some of the SNs to relay the local decisions from the surrounding SNs to the other SNs out of reach.

In the relay aided network topology the network is composed by a central node, CN, one or several sensing nodes, SN, and one or several relay nodes,

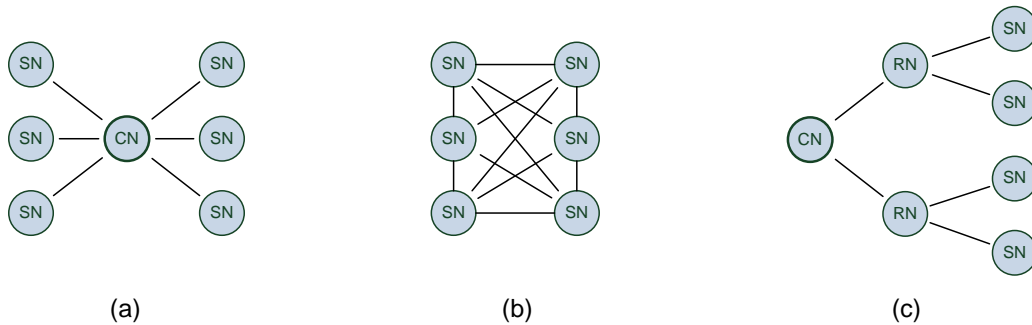

Figure 2.3: (a) Centralized Topology, (b) Decentralized Topology, (c) Relay aided Topology

Relay Node (RN), Figure 2.3(c). In the relay aided topology the SNs might not be able to connect directly with the CN and therefore in those cases the communications are always performed through a RN. The need for the relay aided topology comes since the sensing channel and the report channel are not perfect, and therefore a SN experiencing a weak sensing channel and a strong report channel and a SN with a strong sensing channel and a weak report channel can complement and cooperate with each other to improve the performance of cooperative sensing. The example depicted in Figure 2.3(c) depicts a centralized topology aided by relays, but these relays can of course be also applied to the decentralized case and in that case it might be needed to perform multi-hopping and so the intervening SNs will also act as relays.

## 2.4 Local Decisions Fusion

After the local decisions from the surrounding CRN nodes are collected, these need to be combined so that a global decision is reached. Data fusion is the process through which the global decision is accomplished, i.e. it is the process where the local sensing data is combined to allow hypothesis testing. The local sensing data can be of different forms, size and type, being in general limited by the control channel reporting available bandwidth. The combined of the sensing results can be classified as:

- Soft Combining - CRN nodes transmit the entire local sensing samples or the complete local test statistics for soft decision, [22, 31];

- Quantized Soft Combining - CRN nodes quantize the local sensing results and send only the quantized data for soft combining to alleviate control channel communication overhead, [22, 31];
- Hard Combining - CRN nodes make a local decision and transmit the one-bit decision for hard combining at the data fusion center, [27, 25, 39, 36].

From these, the soft combining is the one that allows for a superior detection performance, since there is more information in the shared local sensing data, although at the cost of control channel bandwidth, while quantized and hard combining require less control channel bandwidth at the cost of degraded detection performance due to loss of information due to the quantization.

## 2.5 Knowledge Base Update

While performing CSS, the CRN accumulates over time data regarding the spectrum allocation conditions at its surroundings. This information is built by combining past observation with the current derived observations. This accumulated information can be used to improve the network performance as well as to improve the CSS schemes performance. This accumulated information can take the form of traffic patterns, location and transmit power of channel incumbents. If this information is available at the time when the decisions are made regarding the presence of a signal in the channel they can help improve the detection performance.

This gathering of information is called in the literature [2, 3] as Knowledge base (KB), and it can be used to assist, complement or even replace CSS in some scenarios, for example in the TV white space band where the position of the broadcasters is publically available.

The KB can be used in two ways, [3], in CSS:

- to enhance the detection performance by utilizing the accumulated knowledge and the learned experience such as statistical models in the database;
- to alleviate the burden of CSS by retrieving the spectrum information such as a list of Primary User (PU) occupied channels from the database.

The KB might be able to provide information regarding the incumbents of the targeted spectrum such as locations, tracking, transmit power, and activity in the forms of spatial temporal spectral maps for cooperative sensing. There

are some examples in the literature how such knowledge can be used to create a KB, being those [3]:

- incumbent duty cycle [28, 30];
- radio environment map [43, 42];
- received signal strength profiles [23];
- channel gain map [16, 17];
- power spectral density [5].

Still there are some issues to address, like who should populate these knowledge base, only the CRN nodes or should there be external entities which can update it so to ensure a more smooth functioning of the CRN, minimizing the interference with incumbent users. A recent Federal Communications Commission (FCC) ruling [1] removed the spectrum sensing requirements in the TV white space band, and so CRN nodes are to access the incumbent activity and spectrum information from a remote knowledge base. Although this ruling removes the SS challenges, it introduces another challenge, on how can the CRN nodes access this remote KB, while considering the scalability issue which will impact on how fast each of the CRN nodes can access the required information.

## 2.6 Node Selection

The cooperation between CRN nodes is controlled by the Node Selection (NS) procedure, which plays a key role on the performance of the CSS since it can influence the cooperative gain as well as address the overhead issues. Considering the case when the cooperating nodes are experiencing the same signal power level conditions, i.e. the node experienced  $SNR$  is correlated, then the cooperative gain will be much less than when the cooperation is done between nodes experiencing uncorrelated channel conditions, as shown in [24]. Although it was shown in [29] the use of uncorrelated nodes in the CSS may decrease the perceived available resources, since the SS measurements can be potentially taken from spread geographical locations. There is also the issue of malicious CRN users which may affect the system performance by sharing erroneous SS data, therefore by performing proper NS these nodes can be discarded from the cooperation group. The NS mechanism besides selecting which CRN nodes to cooperate with each other also selects where these CRN nodes should cooperate, i.e. which spectrum band they should sense.

The NS can be based on two approaches the centralized [30] and decentralized [28]. On the centralized, there is a central entity, normally the CN, which performs the NS, while in the decentralized each CRN node performs the NS itself. The NS is based on the information collected overtime through the SS, i.e. from the KB. More about NS methodologies can be found on [3].

## 2.7 Gain and Overhead

The main driver behind CSS is the exploitation of spatial diversity, which allows to improve the detection performance, where the improvement is termed as cooperative gain [24]. But the use of cooperation adds a variety of overheads that might limit the achievable cooperative gain. This overhead is created by the conditions needed to achieve the cooperation. The elements of cooperative spectrum sensing which affect the cooperation gain and overhead are: sensing time and delay; channel impairments; energy efficiency; cooperation efficiency; mobility; security; and wideband sensing. These items are discussed extensively in [3].

## 2.8 Conclusions

Spectrum sensing is the cornerstone of the cognitive radio paradigm and has therefore been the focus of intensive research, where one of the main conclusions from the research community is that spectrum sensing performance can be greatly enhanced through the use of cooperative sensing schemes.

In this chapter was given an overview on what is cooperative spectrum sensing and what are main channel to be overcome, as well what are the possible gains and possible overhead.

## References

- [1] Second memorandum opinion and order, et docket no. 10-174.
- [2] Ian F. Akyildiz, Won-Yeol Lee, Mehmet C. Vuran, and Shantidev Mohanty. Next generation/dynamic spectrum access/cognitive radio wireless networks: a survey. *Computer Networks*, 50(13):2127–2159, 2006.

- [3] Ian F. Akyildiz, Brandon F. Lo, and Ravikumar Balakrishnan. Cooperative spectrum sensing in cognitive radio networks: A survey. *Physical Communication*, 4(1):40–62, 2011.
- [4] Pedro Alvarez, Nuno Pratas, António Rodrigues, Neeli R. Prasad, and Ramjee Prasad. Energy detection and eigenvalue based detection: An experimental study using gnu radio. In *2011 14th International Symposium on Wireless Personal Multimedia Communications (WPMC 2011)*, pages 1–5, October 2011.
- [5] J. A. Bazerque and G. B. Giannakis. Distributed spectrum sensing for cognitive radio networks by exploiting sparsity. *IEEE Transactions on Signal Processing*, 58(3):1847–1862, March 2010.
- [6] I. Budiarjo, M. Lakshmanan, and H. Nikookar. Cognitive radio dynamic access techniques. *Wireless Personal Communications*, 45:293–324, 2008. 10.1007/s11277-008-9473-6.
- [7] D. Cabric, S.M. Mishra, and R.W. Brodersen. Implementation issues in spectrum sensing for cognitive radios. In *Conference Record of the Thirty-Eighth Asilomar Conference on Signals, Systems and Computers, 2004.*, volume 1, pages 772–776, November 2004.
- [8] D. Cabric, A. Tkachenko, and R. W. Brodersen. Experimental study of spectrum sensing based on energy detection and network cooperation. In *Proceedings of the first international workshop on Technology and policy for accessing spectrum, TAPAS '06*, New York, NY, USA, 2006. ACM.
- [9] D. Cabric, A. Tkachenko, and R.W. Brodersen. Spectrum sensing measurements of pilot, energy, and collaborative detection. In *IEEE Military Communications Conference, 2006. (MILCOM 2006)*, pages 1–7, October 2006.
- [10] E.J. Candes, J. Romberg, and T. Tao. Robust uncertainty principles: exact signal reconstruction from highly incomplete frequency information. *IEEE Transactions on Information Theory*, 52(2):489–509, February 2006.
- [11] K.C. Chen and R. Prasad. *Cognitive Radio Networks*. John Wiley and Sons Ltd, April 2009.
- [12] F. F. Digham, M.-S. Alouini, and M. K. Simon. On the energy detection of unknown signals over fading channels. *IEEE Transactions on Communications*, 55(1):21–24, January 2007.

## REFERENCES

---

- [13] D.L. Donoho. Compressed sensing. *IEEE Transactions on Information Theory*, 52(4):1289–1306, 2006.
- [14] A. Fehske, J. Gaeddert, and J.H. Reed. A new approach to signal classification using spectral correlation and neural networks. In *First IEEE International Symposium on New Frontiers in Dynamic Spectrum Access Networks, 2005. (DySPAN 2005)*, pages 144–150, November 2005.
- [15] W.A. Gardner. Signal interception: a unifying theoretical framework for feature detection. *IEEE Transactions on Communications*, 36(8):897–906, August 1988.
- [16] S. J. Kim, E. Dall’Anese, and G. B. Giannakis. Sparsity-aware cooperative cognitive radio sensing using channel gain maps. In *Conference Record of the Forty-Third Asilomar Conference on Signals, Systems and Computers, 2009*, pages 518–522, November 2009.
- [17] S. J. Kim, E. Dall’Anese, and G. B. Giannakis. Cooperative spectrum sensing for cognitive radios using kriged kalman filtering. *IEEE Journal of Selected Topics in Signal Processing*, 5(1):24–36, February 2011.
- [18] Ben K. Letaief and Wei Zhang. Cooperative communications for cognitive radio networks. *Proceedings of the IEEE*, 97(5):878–893, May 2009.
- [19] Sunmin Lim, Hoiyoon Jung, and Myung Sun Song. Cooperative spectrum sensing for ieee 802.22 wran system. In *Proceedings of 18th International Conference on Computer Communications and Networks, 2009. (ICCCN 2009)*, pages 1–5, August 2009.
- [20] J. Lunden, V. Koivunen, A. Huttunen, and H.V. Poor. Collaborative cyclostationary spectrum sensing for cognitive radio systems. *IEEE Transactions on Signal Processing*, 57(11):4182–4195, November 2009.
- [21] Jun Ma, G.Y. Li, and Biing Hwang Juang. Signal processing in cognitive radio. *Proceedings of the IEEE*, 97(5):805–823, May 2009.
- [22] Jun Ma, Guodong Zhao, and Ye Li. Soft combination and detection for cooperative spectrum sensing in cognitive radio networks. *IEEE Transactions on Wireless Communications*, 7(11):4502–4507, November 2008.
- [23] A.W. Min and K.G. Shin. An optimal sensing framework based on spatial rss-profile in cognitive radio networks. In *6th Annual IEEE Communications Society Conference on Sensor, Mesh and Ad Hoc Communications and Networks, 2009. (SECON 2009)*, pages 1–9, June 2009.

- [24] S.M. Mishra, A. Sahai, and R.W. Brodersen. Cooperative sensing among cognitive radios. In *IEEE International Conference on Communications, 2006. (ICC 2006)*, volume 4, pages 1658–1663, 2006.
- [25] E.C.Y. Peh, Y. C. Liang, and Y. L. Guan. Optimization of cooperative sensing in cognitive radio networks: A sensing-throughput tradeoff view. In *IEEE International Conference on Communications, 2009. (ICC 2009)*, pages 1–5, June 2009.
- [26] Federico Penna, Roberto Garello, and Maurizio A. Spirito. Cooperative spectrum sensing based on the limiting eigenvalue ratio distribution in wishart matrices. *Comm. Letters.*, 13:507–509, July 2009.
- [27] N. Pratas, N. Marchetti, N. R. Prasad, R. Prasad, and A. Rodrigues. Adaptive counting rule for cooperative spectrum sensing under correlated environments. *Proceedings Wireless Personal Multimedia Communications Symposia*, 2010:S11–1, 2010.
- [28] N. Pratas, N. Marchetti, N. R. Prasad, A. Rodrigues, and R. Prasad. Decentralized cooperative spectrum sensing for ad-hoc disaster relief network clusters. In *IEEE 71st Vehicular Technology Conference (VTC 2010-Spring)*, pages 1–5, May 2010.
- [29] N. Pratas, N. Marchetti, N. R. Prasad, A. Rodrigues, and R. Prasad. System capacity limits introduced by data fusion on cooperative spectrum sensing under correlated environments. *MTA Review*, XX(4):245–262, 2010.
- [30] N. Pratas, N. Marchetti, N.R. Prasad, A. Rodrigues, and R. Prasad. Centralized cooperative spectrum sensing for ad-hoc disaster relief network clusters. In *IEEE International Conference on Communications (ICC 2010)*, pages 1–5, May 2010.
- [31] Z. Quan, S. Cui, and A. H. Sayed. Optimal linear cooperation for spectrum sensing in cognitive radio networks. *IEEE Journal of Selected Topics in Signal Processing*, 2:28–40, February 2008.
- [32] Zhi Quan, Shuguang Cui, A.H. Sayed, and H.V. Poor. Optimal multiband joint detection for spectrum sensing in cognitive radio networks. *IEEE Transactions on Signal Processing*, 57(3):1128–1140, March 2009.
- [33] R. Tandra and A. Sahai. Snr walls for signal detection. *IEEE Journal of Selected Topics in Signal Processing*, 2(1):4–17, February 2008.



## REFERENCES

---

- [34] Zhi Tian and G.B. Giannakis. Compressed sensing for wideband cognitive radios. In *IEEE International Conference on Acoustics, Speech and Signal Processing, 2007. (ICASSP 2007)*, volume 4, pages IV–1357 –IV–1360, April 2007.
- [35] Zhi Tian and Georgios B. Giannakis. A wavelet approach to wideband spectrum sensing for cognitive radios. In *1st International Conference on Cognitive Radio Oriented Wireless Networks and Communications, 2006*, pages 1 –5, June 2006.
- [36] J. Unnikrishnan and V.V. Veeravalli. Cooperative sensing for primary detection in cognitive radio. *IEEE Journal of Selected Topics in Signal Processing*, 2(1):18 –27, February 2008.
- [37] H. Urkowitz. Energy detection of unknown deterministic signals. *Proceedings of the IEEE*, 55(4):523–531, April 1967.
- [38] Pramod K. Varshney. *Distributed Detection and Data Fusion*. Springer-Verlag New York, Inc., Secaucus, NJ, USA, 1st edition, 1996.
- [39] Xiao Fan Wang and Guanrong Chen. Complex networks: small-world, scale-free and beyond. *IEEE Circuits and Systems Magazine*, 3(1):6 – 20, 2003.
- [40] Yonghong Zeng, Choo Leng Koh, and Ying-Chang Liang. Maximum eigenvalue detection: Theory and application. In *IEEE International Conference on Communications, 2008. (ICC 2008)*, pages 4160 –4164, May 2008.
- [41] Yonghong Zeng and Ying-Chang Liang. Eigenvalue-based spectrum sensing algorithms for cognitive radio. *IEEE Transactions in communications*, 57:1784–1793, June 2009.
- [42] Youping Zhao, Joseph Gaeddert, Lizdabel Morales, Kyung Bae, Jung-Sun Um, and Jeffrey H. Reed. Development of radio environment map enabled case- and knowledge-based learning algorithms for ieee 802.22 wran cognitive engines. In *2nd International Conference on Cognitive Radio Oriented Wireless Networks and Communications, 2007. CrownCom 2007*, pages 44 –49, August 2007.
- [43] Youping Zhao, L. Morales, J. Gaeddert, K.K. Bae, Jung-Sun Um, and J.H. Reed. Applying radio environment maps to cognitive wireless regional area networks. In *2nd IEEE International Symposium on New Frontiers in Dynamic Spectrum Access Networks, 2007. (DySPAN 2007)*, pages 115 –118, April 2007.

# 3

## Reasoning about Distributed Cooperative Spectrum Sensing Protocols Correctness

### 3.1 Introduction

The goals of a Cooperative Spectrum Sensing (CSS) mechanism is to ensure that all the Cognitive Radio Network (CRN) nodes know which spectrum to sense and when to sense, how to share the results from the sensing and how to ensure that all CRN nodes have an updated and synchronized information about the state of the monitored spectrum.

In the literature one can find several proposals on how to establish this cooperation mechanism, as discussed in Chapter 2. In general, these can be classified according to the assumptions made on the topology of the network, i.e. whether it is *centralized*, *decentralized* or *relay-assisted*. In each proposed mechanism, there is a *protocol* in the form of a distributed algorithm which allows to achieve the CSS mechanism goals. However, little work has been done to model and analyse the algorithmic correctness of these same protocols. In the case of CSS, a protocol is considered correct if it allows the CRN nodes to perform the stated CSS mechanism goals. Most proposals found in the

literature focus on the analysis of the performance of the algorithms upon implementation, be it through theoretical modelling, simulation or real system implementation, i.e. they give a quantitative analysis, while in this chapter the focus is on the analysis of the underlying properties of the algorithms which enable the CSS, such as correctness, therefore a qualitative analysis.

A CSS mechanism can be expressed, as discussed in Chapter 2, by the flow diagram depicted in Figure 3.1, a generalized version of the one proposed in [13, 12]. From this flow diagram four elemental components, or modules, of the CSS can be identified. These are the Spectrum Sensing (SS), Local Decisions Data Fusion (LDDF), Knowledge Base Update (KBU) and Node Selection (NS). In this chapter, the implementation of these components is not discussed, they are considered to be black boxes which are able to exchange messages with the other CSS components. Instead the focus is on the message exchange, i.e. on the distributed protocol which enables the CSS.

A CRN which implements a CSS, as discussed in Chapter 2, can be organized in one of three topologies, a *centralized*, a *decentralized* or *relay-assisted* one, all depicted in Figure 3.2. The network nodes can assume different functionalities in regards to the CSS depending on the network topology in place. In the centralized topology there is a Central Node (CN) and several Sensing Nodes (SNs) while in the relay based topology there are also Relay Nodes (RNs), while in the decentralized topology there are only SNs.

To allow the cooperation to be established between each of CRN nodes, there is the need for these CRN nodes to be able to have access to a Common Control Channel (CCH). Here is assumed that such a channel exists and that it is divided in the time domain by control frames of equal duration, in which the control frames are further divided in time as shown in Figure 3.3. The control exchanges part of the frame is used by the CRN nodes to exchange any signalling information not related to CSS. While the sensing exchanges part is where all the exchanges related to the CSS occur. Note that all the CRN nodes are assumed to be registered with each other when the network is

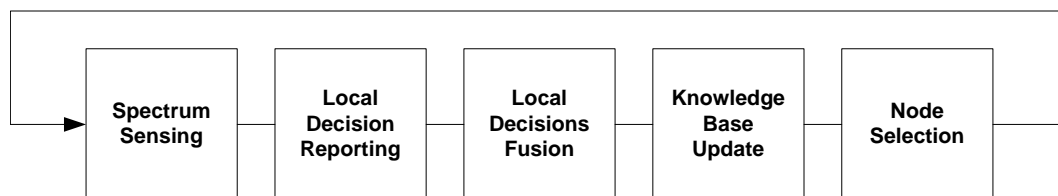

Figure 3.1: Distributed spectrum sensing mechanism flow

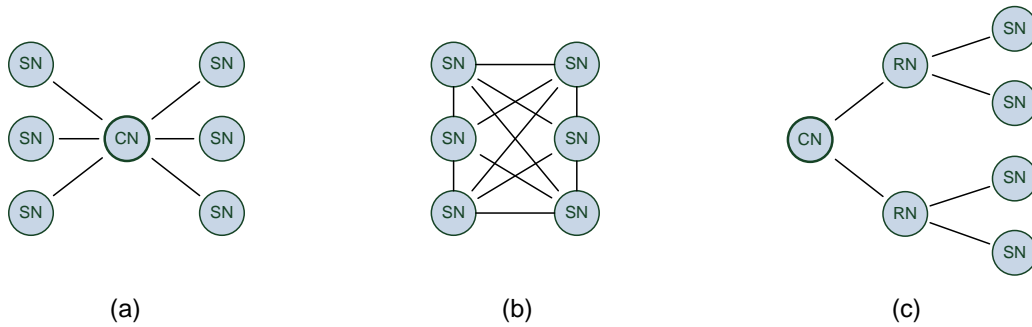

Figure 3.2: (a) Centralized Topology, (b) Decentralized Topology, (c) Relay Topology

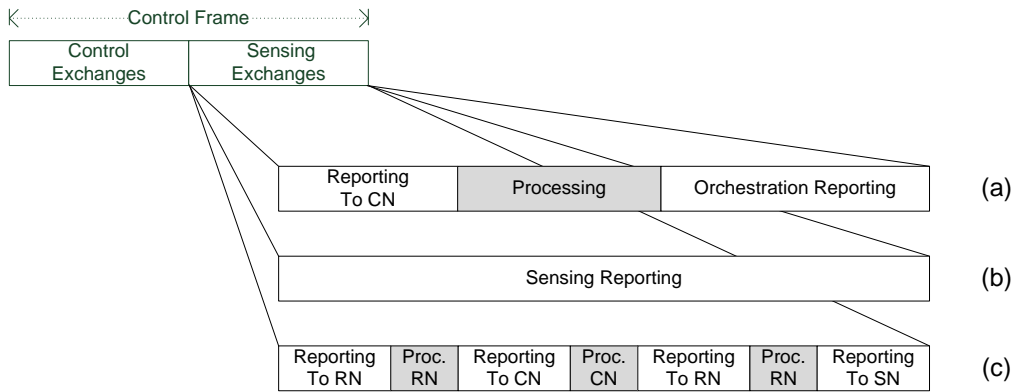

Figure 3.3: Control Frame: (a) centralized, (b) decentralized, (c) relay aided

instatiated, therefore the node registration procedure is not discussed in this thesis.

### 3.2 Reasoning about protocols using process calculi

As a motivating example, consider the scenario depicted in Figure 3.4, where there is one Sensing Node (SN) and one CN. In this scenario, the SN senses the state of the channel being monitored and reaches a local decision regarding the state of that same channel. Then the SN forwards the local decision, denoted as the *ss* message, to the CN. The CN then processes the received message and informs the SN of its global decision, denoted as the *sd* message. All these

message exchanges are done through the common control channels denoted by  $cc_d$  (downlink) and  $cc_u$  (uplink).

The question is now: how can it be stated and shown that the protocol works as described, i.e. that it will indeed perform the described interactions? To this end a *process calculus* is employed.

Process calculi arise in computer science as a mathematical frameworks for describing aspects of distributed and parallel computations, analogous to the role played by Turing machines and lambda calculus in computability theory. The topic originated around 1980 with the seminal work of Milner [8] and there is now an extensive body of work on both the mathematical foundations and the applications to reasoning about phenomena distributed and parallel computing. In most process calculi, the parallel components of a system interact through communication, and very often this communication is described as point-to-point communication over named channels. The system in Figure 3.4 can be described using the process calculus notation as

$$S = \underbrace{\overline{cc_u}\langle 1 \rangle . cc_d(b) . \bar{x}\langle b \rangle}_{SN} \mid \underbrace{cc_u(a) . \overline{cc_d}\langle 1 + a \rangle}_{CN}. \quad (3.1)$$

This system uses two channels named respectively  $cc_u$  and  $cc_d$ . Parallel composition is denoted by the bar  $\mid$ . If we let overlined names denote output actions and all other names denote input actions, the intuition is that the system will first allow the component SN to output 1 on the channel  $cc_u$  and allow the CN component to receive a message, also on the channel  $cc_u$ . The CN component can then output the result of the sum on the  $cc_d$ -channel. After its initial output, SN can receive a value on the  $cc_d$ -channel and subsequently output it on the  $x$ -channel.

Around 1990, Milner et al. proposed the  $\pi$ -calculus [9, 10] as a process calculus for describing parallel computations that involve notions of mobility. A central insight is that mobility involves passing references in the form of *names*.

Considering a modified version of the described system now with labels, denoted by

$$S = \underbrace{\overline{cc_u}\langle cc_d \rangle . \overline{cc_u}\langle ss \rangle . cc_d(c) . \bar{x}\langle b \rangle}_{SN} \mid \underbrace{cc_u(a) . cc_u(b) . \bar{a}\langle sd(b) \rangle}_{CN}. \quad (3.2)$$

Here, SN is now able to send a channel name  $cc_d$ , which CN can receive. Upon reception, CN can then use the  $cc_d$ -channel for communicating with SN. Channels may have *scope*; in a further modification, the scope of  $cc_d$  can also

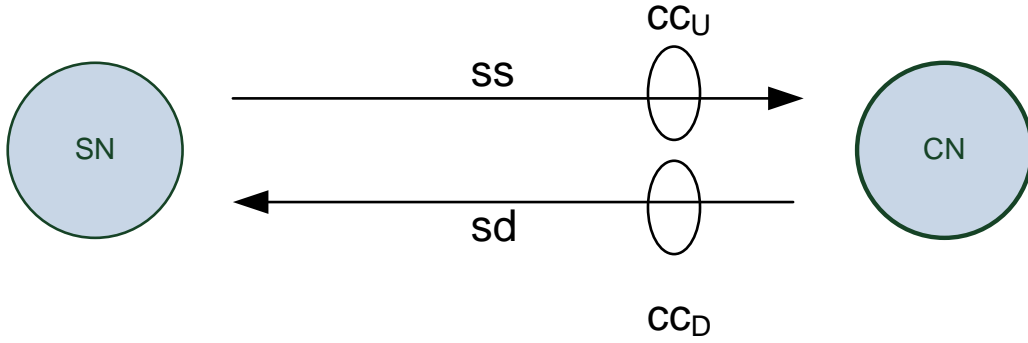

Figure 3.4: A simple protocol

be restricted to SN using a  $\nu$ -binder.

$$S = (\nu cc_d) \left( \underbrace{\overline{cc_u}\langle cc_d \rangle . \overline{cc_u}\langle ss \rangle . cc_d(c) . \bar{x}\langle b \rangle}_{SN} \mid \underbrace{cc_u(a) . cc_u(b) . \bar{a}\langle sd(b) \rangle}_{CN} \right). \quad (3.3)$$

After the first communication on the  $cc_u$ -channel, this scope will now be extended to also include CN as follows.

$$S = (\nu cc_d) \left( \underbrace{\overline{cc_u}\langle ss \rangle . cc_d(c) . \bar{x}\langle b \rangle}_{SN} \mid \underbrace{cc_u(b) . \overline{cc_d}\langle sd(b) \rangle}_{CN} \right). \quad (3.4)$$

A large variety of process calculi that extend the  $\pi$ -calculus have been proposed. Some variants of the  $\pi$ -calculus, notably the distributed  $\pi$ -calculus due to Hennessy and Riely [6, 14] introduce notions of locality; here a process  $P$  is located at a named location  $\ell$  and is thus written  $\ell[P]$ . In other variants of the  $\pi$ -calculus, a notion of broadcast communication has been introduced, notably by Ene and Muntian [3]. These approaches have led to a body of work devoted to understanding the computational properties of mobile ad hoc networks by means of process calculi. Some of this work has focused on security properties, while other work has focused on timing properties [1, 11, 7].

Revisiting the system depicted in Figure 3.4, it can be shown how the system evolves.

$$S = \underbrace{\overline{cc_u}\langle ss \rangle . cc_d(b) . \bar{d}\langle b \rangle}_{SN} \mid \underbrace{cc_u(a) . \overline{cc_d}\langle sd(a) \rangle}_{CN} \longrightarrow \quad (3.5)$$

$$\overline{cc_u}\langle ss \rangle . cc_d(b) . \bar{d}\langle b \rangle \mid cc_u(a) . \overline{cc_d}\langle sd(a) \rangle \longrightarrow \quad (3.6)$$

$$cc_d(b) . \bar{d}\langle b \rangle \mid \overline{cc_d}\langle sd(ss) \rangle \longrightarrow \quad (3.7)$$

$$\bar{d}\langle sd(ss) \rangle \quad (3.8)$$

So a simple exchange of messages has been described, through which it is possible to see how the messages can be exchanged, allowing to study the network configuration across several states.

In the remaining of this chapter the computational properties of distributed protocols which enable the CSS mechanism are described and reasoned about. Here an extension of the variant of the  $\pi$ -calculus with located processes and broadcast communication introduced by Godskesen et al. [5] is considered. Three different protocols are proposed, according to the underlying topology, for sensing and selecting which radio channels should be sensed in the CRN context and are also proved to be correct *for any number of nodes* using the defined process calculus techniques.

### 3.3 Network Description

Here the network topologies illustrated in Figure 3.2 are described using a process calculus, which will be defined formally in Section 3.4. All the communications related to the CSS, including message relaying, are performed through a CCH, denoted as  $cc$ . In the following descriptions, the notation  $\prod_{i \in I} P_i$  is used to denote the parallel composition of a finite set of network components, each denoted by  $P_i$  with  $i$  in some index set  $I$ .

In the *centralized network topology* the network is composed by a CN and one or several SNs. The centralized network topology is defined using the process calculus notation as,

$$S \equiv (\nu \vec{c}) \left( \prod_{i \in I} cl \bowtie sl_i \right) | CN | \prod_{i \in I} SN_i \quad (3.9)$$

where  $CN$  represents the central node,  $SN_i$  is the  $i^{th}$  sensing node and  $I$  is the index set of sensing nodes.  $cl$  and  $sl_i$  are the locations of the  $CN$  and the  $i^{th}$   $SN$ , respectively. The operator  $\bowtie$  denotes that the locations are near each other, i.e. any communication established between processes at these locations is bidirectional. The  $\equiv$  operator denotes the structural congruence, which is a relation that states that two processes or networks are related, if they are identical up to simple structural modifications such as the ordering of parallel components. The purpose of structural congruence is discussed further in Section 3.4.2.

In the *decentralized network topology* the network is composed only of SNs. The decentralized network topology is defined as,

$$S \equiv (\nu\vec{c}\vec{c}) \left( \prod_{i,j \in I, i \neq j} sl_i \bowtie sl_j \right) \mid \prod_{i \in I} SN_i \quad (3.10)$$

where  $SN_i$  is the  $i^{th}$  sensing node and  $sl_i$  is the location of the  $i^{th}$  SN.

In the *relay-based network topology* the network is composed by a CN one or several SNs and one or several RNs. It is assumed that in this topology the SNs are not able to connect directly with the CN and therefore the communications are always performed through a Relay Node (RN). To ease the presentation here is considered that between a given SN and the CN there is only one RN. The relay based network topology is defined as,

$$S \equiv (\nu\vec{c}\vec{c}) \left( \prod_{j \in J} cl \bowtie rl_j \mid \prod_{j \in J} \prod_{i \in I_j} sl_i \bowtie rl_j \right) \mid CN \mid \prod_{j \in J} RN_j \mid \prod_{i \in \bigcup_{j \in J} I_j} SN_i \quad (3.11)$$

where  $SN_i$  is the  $i^{th}$  sensing node,  $I$  is the index set of sensing nodes,  $RN_j$  is the relay node and  $J$  is the set of relay nodes.  $cl$ ,  $sl_i$  and  $rl_j$  are the locations of the  $CN$ , the  $i^{th}$  SN and the  $j^{th}$  RN, respectively.

## 3.4 Bounded Broadcast Calculus

In this section the proposed Process Calculus (PC), denoted as Bounded Broadcast Calculus (BBC), is defined formally, together with the new additions to the PC which allow to model and reason about a CSS.

### 3.4.1 Syntax

The BBC has locations similar to that of the PC proposed by Godskesen et al. [5]. In the BBC, processes reside at named sites, called *locations*, and use named *channels* for communication. Thus, a central notion is that of *names*, and that  $a, x \in \mathbf{Names}$ , a countably infinite set of names. A parallel composition of these located processes is called a *network*.

The set of networks is called **Nets**, the set of processes is called **Proc**, the set of messages is denoted **Msg**. The formation rules defining these three sets



---

$M$	$::= x \mid (M_1, \dots, M_k) \mid f(M)$
$P$	$::= a((\lambda \vec{x})M).P_1 \mid \bar{a}\langle M \rangle.P_1 \mid (\nu x)P_1 \mid [M = N]P_1 \mid [M \neq N]P_1$ $\mid P_1 \mid P_2 \mid P_1 + P_2 \mid \mathbf{0} \mid *P_1 \mid A(\vec{n})$
$N$	$::= l[P] \mid N_1 \mid N_2 \mid (\nu x)N \mid \psi$
$\psi$	$::= l \triangleright m$

---

Table 3.1: Formation rules

are given in Table 3.1. A *message*  $M$  can be a name  $x$ , a vector of messages  $(M_1, \dots, M_k)$  or a message  $f(M)$  where a function symbol  $f$ , where  $f \in \mathbf{Fun}$  (a finite set of function symbols), has been applied to argument  $M$ . Note that  $f$  is viewed as a message constructor, i.e. as a tag; no actual evaluation of composite messages is assumed. In the BBC lists of names are used often. Two important function symbols are therefore the list constructors  $::$  and  $[]$ ;  $[]$  denotes the empty list and  $b :: l$  denotes the list whose head element is  $b$  and whose tail is the list  $l$ .

From the formation rules, a *process*  $P$  can be seen as one of the following:

- An *input* process  $a((\lambda \vec{x})M).P_1$  which asks for a message on the channel named  $a$  and, if the received message  $N$  matches the *input pattern*  $(\lambda \vec{x})M$  (defined formally below), then the process continues as the instantiation  $P_1\theta$ . A process  $a((\lambda x)x).P_1$  is written  $a(x).P_1$ .
- An *output* process  $\bar{a}\langle M \rangle.P_1$  sends out the message  $M$  on the channel named  $a$  and then continues as  $P_1$ .
- A *restriction*  $(\nu x)P_1$  declares the name  $x$  to be private within  $P_1$ .
- A *match*  $[M = N]P_1$  proceeds as  $P_1$  if  $M$  and  $N$  are the same term.
- A *parallel composition*  $P_1 \mid P_2$  runs the parallel components  $P_1$  and  $P_2$  in parallel.
- A *mismatch*  $[M \neq N]P_1$  proceeds as  $P_1$  if  $M$  and  $N$  are distinct terms.
- A *nondeterministic choice*  $P_1 + P_2$  can proceed as either  $P_1$  or  $P_2$ .
- An *inaction*  $\mathbf{0}$  has no behaviour.
- A *replication* of process  $P$  is denoted as  $*P$ . A replicated process  $*P$  is expressed by the agent identifier  $A_P$  whose defining equation is  $A_P = P \mid A_P$  and should therefore be thought of as an unbounded supply of parallel copies of  $P$ .

- Agent identifiers  $A(\vec{n})$  parameterized by a sequence of names; an identifier must be defined using an equation of the form  $A(\vec{x}) \stackrel{\text{def}}{=} P$ . Definitions of this form can be recursive, with occurrences of  $A(\vec{x})$  (with names in  $\vec{x}$  instantiated by concrete names) occurring within  $P$ .

An *input pattern* is of the form  $(\lambda\vec{x})M$ , where the variable names in  $\vec{x}$  are distinct and occur free in  $M$ . A message  $N$  matches this pattern, if it can be obtained from it by a substitution. More formally, a *term substitution* is a finite function  $\theta : \mathbf{Names} \rightarrow \mathbf{Msg}$ . The substitution can also be written as a list of bindings  $\theta = [x_1 \mapsto n_1, \dots, x_k \mapsto n_k]$ .

The action of  $\theta$  on an arbitrary message can be defined by the clauses

$$x\theta \stackrel{\text{def}}{=} \theta(x) \quad (3.12)$$

$$f(M)\theta \stackrel{\text{def}}{=} f(M\theta) \quad (3.13)$$

$$(M_1, \dots, M_k) \stackrel{\text{def}}{=} (M_1\theta, \dots, M_k\theta) \quad (3.14)$$

$N$  is said to match  $(\lambda\vec{x})M$  with  $\theta$  if for a substitution  $\theta$  with  $\text{dom}(\theta) = \vec{x}$   $N = M\theta$  is true.

For any process  $P$ ,  $\text{fn}(P)$  the set of *free names* of  $P$ , can be defined. This is the set of names that are not bound by a restriction or an input pattern. More formally,  $\text{fn}(P)$  is the least set satisfying the equations found in Table 3.2.

A *network*  $N$  is a collection of located processes running in parallel. The operators of parallel composition and restriction can also be applied at this level;  $l[P]$  denotes the process  $P$  running at location  $l$ .  $\psi$  is a *proximity predicate*;  $l \triangleright k$  denotes that location  $l$  is close to  $k$ . For these proximity predicates, parallel composition is thought of as logical conjunction. So, if  $l$  and  $k$  are close to each other, then  $l \bowtie m$  can be written instead of  $l \triangleright m \mid m \triangleright l$ .

### 3.4.2 Structural congruence and normal form

Structural congruence  $\equiv$  is a relation defined for both processes and networks; the intuition is that two processes (or networks) are related, if they are identical up to simple structural modifications such as the ordering of parallel components. The relation is defined as the least equivalence relation satisfying the proof rules and axioms of Tables 3.3 and 3.4.

In the rules defining structural congruence, it is described that parallel composition is commutative and associative both at the level of processes (rules

---

$\text{fn}(a((\lambda \vec{x})M).P_1)$	$= \text{fn}(P_1) \setminus \{\vec{x}\}$
$\text{fn}(\bar{a}\langle M \rangle.P_1)$	$= \{a\} \cup \text{fn}(M) \cup \text{fn}(P)$
$\text{fn}((\nu x)P_1)$	$= \text{fn}(P_1) \setminus \{x\}$
$\text{fn}([M = N]P_1)$	$= \text{fn}(M) \cup \text{fn}(N) \cup \text{fn}(P_1)$
$\text{fn}([M \neq N]P_1)$	$= \text{fn}(M) \cup \text{fn}(N) \cup \text{fn}(P_1)$
$\text{fn}(P_1 \mid P_2)$	$= \text{fn}(P_1) \cup \text{fn}(P_2)$
$\text{fn}(\mathbf{0})$	$= \emptyset$
$\text{fn}(A(\vec{n}))$	$= \text{fn}(P) \quad \text{if } A(\vec{x}) \stackrel{\text{def}}{=} P$

---

Table 3.2: Free names

---

(P-COM)	$P_1 \mid P_2 \equiv P_2 \mid P_1$
(P-AS)	$(P_1 \mid P_2) \mid P_3 \equiv P_1 \mid (P_2 \mid P_3)$
(P-COM-PLUS)	$P_1 + P_2 \equiv P_2 + P_1$
(P-AS-PLUS)	$(P_1 + P_2) + P_3 \equiv P_1 + (P_2 + P_3)$
(P-NIL)	$P \mid \mathbf{0} \equiv P$
(P-EXT)	$(\nu x)(P_1 \mid P_2) \equiv (\nu x)P_1 \mid P_2 \text{ if } x \notin \text{fn}(P_2)$
(P-NEW)	$(\nu x)(\nu y)P \equiv (\nu y)(\nu x)P$
(P-EQ-1)	$[M = M]P \equiv P$
(P-EQ-2)	$[M \neq N]P \equiv P$
(P-AG)	$\frac{A(\vec{x}) \stackrel{\text{def}}{=} P}{A(\vec{n}) \equiv P\theta}$ where $\theta = [x_1 \mapsto n_1, \dots, x_k \mapsto n_k]$

---

Table 3.3: Structural congruence for processes

(P-COM) and (P-AS)) and of networks (rules (N-COM) and (N-AS)). This justifies the use of iterated parallel composition  $\prod_{i \in I} P_i$  introduced earlier.

The restriction axioms describe the scope rules of name restrictions. The scope extension axioms (P-EXT) and (N-EXT) tells that the scope of an extension can be safely extended to cover another parallel component if the restricted name does not appear free in this component. The exchange axioms (P-NEW) and (N-NEW) makes it possible to exchange the order of restrictions.

Finally, the agent axiom (P-AG) tells that an instantiated agent identifier  $A(\vec{n})$  should be seen as the same as the right-hand side of its defining equation  $A(\vec{x}) = P$  instantiated by the substitution  $\theta$  that maps the names in  $\vec{x}$  component-wise to those of  $\vec{n}$ .

For networks, an important axiom is (N-CONG), which expresses that located processes are to be identified, if they have the same location name and if the contents are structurally congruent. The axiom (N-LOC) lets fuse located processes that have the same location name. The axiom (N-NEAR) explains the dynamics of the neighbourhood relation; if a site named  $l$  is near another site  $m$ , then this knowledge is known outside the site as well.

By using the laws of structural congruence, any network can be rewritten to normal form. Informally, a network is on normal form if it consists of the total neighbourhood information as one parallel component and the location information as the other.

**Definition 1.** A network  $N$  is on *normal form* if

$$N \equiv (\nu \vec{m}) \left( \prod_{i \in I} \prod_{j \in J_i} l_i \triangleright m_j \mid \prod_{k \in K} l_k [P_k] \right)$$

**Theorem 1.** For any network  $N$ , there exists a network  $N_1$  such that  $N_1 \equiv N$  and  $N_1$  is on normal form.

*Proof.* Induction in the structure of  $N$ . □

### 3.4.3 Reduction Semantics

The BBC reduction semantics describes the execution steps of terms by means of a reduction relation  $\rightarrow$ , defined using the notion of structural congruence.

The purpose of the semantics of a PC is to define formally how a process will evolve. The definition takes the form of a finite set of reduction rules. In the BBC reduction semantics it is assumed that the network terms are always on normal form; this is justified by Theorem 1. Reductions are of the form  $N \rightarrow N'$  and should be read as saying that the network configuration  $N$  can perform a computational step, following which it will be in configuration  $N'$ .

The semantics of the BBC needs to capture the bounded connectivity of a link in a wireless network and in particular that a signal cannot be received, if too many senders are active on that same link. More precisely, if  $b$  is a positive integer,  $a$  a channel name and  $m$  a location name, then  $b(a, m)$  denotes

---

(N-CONG)	$\frac{P_1 \equiv P_2}{l[P_1] \equiv l[P_2]}$
(N-COM)	$N_1 \mid N_2 \equiv N_2 \mid N_1$
(N-AS)	$(N_1 \mid N_2) \mid N_3 \equiv N_1 \mid (N_2 \mid N_3)$
(N-NIL)	$N \mid \mathbf{0} \equiv N$
(N-EXT)	$(\nu x)(N_1 \mid N_2) \equiv (\nu x)N_1 \mid N_2$ if $x \notin \text{fn}(P_2)$
(N-NEW)	$(\nu x)(\nu y)N \equiv (\nu y)(\nu x)N$
(N-LOC)	$l[P \mid Q] \equiv l[P] \mid l[Q]$
(N-NEAR)	$l[P] \mid l \triangleright m \equiv m[P] \mid l \triangleright m$
(N-EQ)	$(\nu n)l[P] \equiv l[(\nu n)P]$ if $l \neq n$

---

Table 3.4: Structural congruence for networks

the maximum number of senders that may send content on the channel  $a$  to location  $m$ . If more senders than  $b(a, m)$  are able to send content on the  $a$  channel to a process at location  $m$ , then no communication should happen.

Consider the following network example and assume that  $b(a, m) = 2$ .

$$\prod_{i=1}^3 l_i \triangleright m \mid l_1[\bar{a}\langle M_1 \rangle.P_1] \mid l_2[\bar{a}\langle M_2 \rangle.P_2] \mid l_3[\bar{a}\langle M_3 \rangle.P_3] \mid m[a(x).P_3] \quad (3.15)$$

The process at location  $m$  should not be able to receive a message on the channel named  $a$ , as the location  $m$  has 3 neighbours. If a transmission is to happen, some of the links must first disappear.

The reduction rules which accomplish this, are found in Table 3.5. To capture congestion avoidance, the reduction rule (R-COM) expresses that a communication is only possible for a node if its connectivity is below  $b$ . The rule (R-DROP) expresses that local connectivity can decrease: a link from node  $l_i$  to node  $m$  can spontaneously disappear if the total number of links to  $m$  exceeds  $b$ .

---

(R-COM)	$(\nu\vec{n})(\prod_{i \in I} \prod_{j \in J_i} l_i \triangleright m_j \mid \prod_{k \in K} l_k[\bar{a}\langle M_k \rangle.P_k \mid P'_k] \mid \prod_{\ell \in L} m_\ell[a((\lambda\vec{x})M'_\ell).Q_\ell] \mid R)$ $\rightarrow$ $(\nu\vec{n})(\prod_{i \in I} \prod_{j \in J_i} l_i \triangleright m_j \mid \prod_{k \in K \setminus \{j\}} l_k[\bar{a}\langle M_k \rangle.P_k \mid P'_k] \mid l_j[P_j \mid P'_j] \mid \prod_{\ell \in L} m_\ell[Q_\ell \theta_\ell] \mid R)$ <p style="margin-left: 20px;">where <math>l_j \triangleright m_\ell</math> and <math>1 &lt; \{l_j \mid l_j \triangleright m_\ell\} \leq b(a, m_\ell)</math> for all <math>\ell \in L</math>, and for all <math>\ell \in L</math> then <math>M_j = M'_\ell \theta_\ell</math> for some <math>\theta_\ell</math>.</p>
(R-DROP)	$(\nu\vec{n})(\prod_{i \in I} \prod_{j \in J_i} l_i \triangleright m_j \mid \prod_{k \in K} l_k[P_k])$ $\rightarrow$ $((\nu\vec{n})(\prod_{i \in I \setminus \{r\}} \prod_{j \in J_i} l_i \triangleright m_j \mid \prod_{j \in J_k \setminus \{s\}} l_r \triangleright m_j \mid \prod_{k \in K} l_k[P_k]))$ <p style="margin-left: 20px;">for some <math>r \in I, s \in J_i</math> and channel <math>a \in \text{fn}((\nu\vec{n})(\prod_{i \in I} \prod_{j \in J_i} l_i \triangleright m_j \mid \prod_{k \in K} l_k[P_k]))</math> where <math> \{l \mid l \triangleright m_s\}  &gt; b(a, m_s)</math></p>

---

Table 3.5: Reduction rules for networks on normal form, assuming connectivity  $b(a, m)$

### 3.5 Centralized Topology Description

In the centralized network topology, the network nodes can either assume the role of a SN or of a CN.

The SN is the node responsible for performing the SS and is defined as,

$$SN \stackrel{\text{def}}{=} sl[(\nu n_{SN}) * P \mid R_{SN}]$$

where  $P$  is the process which implements the sensing and reporting functionality at the sensing node and  $R_{SN}$  is the process which encapsulates the node functionality which is out of the scope. The SN performs the SS in every sensing iteration, except when it does not receive any information regarding which channel to sense from the CN.

The CN is responsible for the LDDF, KBU and the NS in each sensing iteration, and is defined as follows,

$$CN \stackrel{\text{def}}{=} cl \left[ (\nu n_{CN}) * \left( \prod_{m \in M} Q_m \mid T \right) \mid R_{CN} \right] \quad (3.16)$$

where  $Q_m$  is the process which deals with the LDDF and KBU of the  $m^{\text{th}}$  channel.  $T$  is the process on which the NS occurs after each sensing iteration, and  $R_{CN}$  represents any other functionality which is out of scope.

### 3.5.1 Spectrum Sensing

The process  $P$  is divided in three subprocesses and is defined as

$$P \stackrel{\text{def}}{=} P_1 | P_2 | P_3 \quad (3.17)$$

$P_1$  is the subprocess which receives the information about which channel should the SN sense in the next sensing iteration, and is defined as

$$P_1 \stackrel{\text{def}}{=} cc(\lambda(x, y)(x, y)) \text{ if } x = n_{CN} \text{ then } \bar{e}\langle y \rangle \quad (3.18)$$

where  $cc$  is the CCH through which all control messages are exchanged between the network nodes. The input process checks if the message has the correct pattern and checks also if the originator of the message is the CN. This is done by comparing the id of the message,  $x$ , with the id of the CN, given by  $n_{CN}$ .  $y$  is the message with the information about the label of the channel which should be sensed, and  $e$  the communication link to the  $P_2$  subprocess.

$P_2$  is the subprocess where the SS occurs, and is defined as

$$P_2 \stackrel{\text{def}}{=} e(a).\bar{f}\langle SS(a) \rangle \quad (3.19)$$

where  $SS$  is the spectrum sensing function, and  $f$  is the communication link with the reporting process,  $P_3$ . The output of the  $SS$  function is a decision about the state of the sensed channel, which from now on is referred as the *local decision*.

$P_3$  is the subprocess where the state of the sensed spectrum is reported to the network, and is defined as

$$P_3 \stackrel{\text{def}}{=} f(b).\bar{cc}\langle (n_{SN}, b) \rangle \quad (3.20)$$

### 3.5.2 Data Fusion and Knowledge Base Update

$Q_m$  is the process where the LDDF and KBU of the  $m^{th}$  channel is performed. The data fusion and channel state estimation is done separately for each of the sensed channels. To perform these functions first the information about the local decision at each of the SNs, needs to be received and collected, this is implemented by subprocess  $Q_{m1}$ . Then the received data is processed through the LDDF function, this is implemented in subprocess  $Q_{m2}$ . Finally the KBU function is executed from the current and past measurements, this is implemented by subprocess  $Q_{m3}$ . The subprocess  $Q_{m4}$  implements the case where

the CN does not receive any information from the SNs, and therefore cannot perform LDDF, but it still sends the result of the KBU to the NS function.

The  $Q_m$  process is defined by,

$$Q_m \stackrel{\text{def}}{=} Q_{m1} | Q_{m2} | Q_{m3} + Q_{m4} \quad (3.21)$$

The  $Q_{m1}$  is defined as,

$$Q_{m1} \stackrel{\text{def}}{=} C_m (\[]) \quad (3.22)$$

Here  $C_m$  is an agent identifier that represents how the local decisions regarding the state of the sensed channel  $m$  at each of the sensing nodes is collected.  $C_m$  is parameterized by the list of names that have been collected so far and is defined by

$$C_m(l) \stackrel{\text{def}}{=} cc(\lambda(x, y)(x, y)) \text{ if } x \neq n_{CN} \text{ then } C_m(y :: l) + \overline{d}_m \langle l \rangle \quad (3.23)$$

where the derived state information  $y$  of channel  $m$  according to the  $i_{th}$  node are stored in  $l$ ,  $cc$  is the CCH and  $d$  is the link with the LDDF subprocess. The collection of local decisions ends, when a given number of decisions is collected or the collection period ends.

The  $Q_{m2}$  is defined as

$$Q_{m2} \stackrel{\text{def}}{=} d_m(e) . \overline{g}_m \langle LDDF(e) \rangle \quad (3.24)$$

where the LDDF combines the information received from the SNs in one label, and  $g$  is the link with the KBU subprocess. Note that the inputs of the  $DF$  function are all the local decisions received in regards to channel  $m$  which are then concatenated in  $e$ .

The  $Q_{m3}$  is defined as

$$Q_{m3} \stackrel{\text{def}}{=} g_m(i) . \overline{h} \langle KBU(i) \rangle \quad (3.25)$$

where KBU takes as input the global decision derived through the LDDF function,  $i$ , and  $h$  is the communication link to the subprocess where the NS function takes place.

$Q_{m4}$  is the subprocess which provides KBU of the  $m^{th}$  channel in the case where there is no input sensing information from the SNs. The KBU mechanism runs even if there is no data to feed the LDDF, in this case the KBU is performed with  $\[]$  input, i.e. an empty input.

$$Q_{m4} \stackrel{\text{def}}{=} \overline{h} \langle KBU(\[]) \rangle \quad (3.26)$$



### 3.5.3 Node Selection

The NS is implemented by the process  $T$ . This process uses a collector function to collect the result of the KBU for each of the targeted channels. So  $T$  is composed by the subprocesses  $T_1$  and  $T_2$  which implement the collection of KBU results and NS, respectively.

$$T \stackrel{\text{def}}{=} T_1 \mid T_2 \quad (3.27)$$

$T_1$  implements the collection of KBU results,

$$T_1 \stackrel{\text{def}}{=} C_{KBU}(\[]) \quad (3.28)$$

Here  $C_{KBU}$  is an agent identifier that represents how the KBU results regarding the state of each of the sensed channels is collected.  $C_{KBU}$  is parameterized by the list of names that have been collected so far and is defined by

$$C_{KBU}(l) \stackrel{\text{def}}{=} h(b).C_{KBU}(b :: l) + \bar{k}\langle l \rangle \quad (3.29)$$

where  $b$  is the estimated state of the  $i^{\text{th}}$  channel,  $M$  is the number of channels,  $h$  is the channel where the information about the KBU results comes from and  $k$  is the communication link with the NS subprocess.

$T_2$  is the subprocess through which the NS occurs, and is defined as,

$$T_2 \stackrel{\text{def}}{=} k(e).\bar{c}\langle(n_{CN}, NS(e))\rangle \quad (3.30)$$

where NS is the mechanism which chooses which channel the SNs should sense in the next sensing iteration. From an implementation point of view the output of NS needs to express which channel should each of the SNs sense, this can be accomplished by sending a message which includes a list with the id of the SN paired together with the id of channel to be sensed.

## 3.6 Decentralized Topology Description

In the decentralized network topology the network nodes assume only the role of SN. In this topology the SN is responsible for performing the SS as well as to decide which channel to sense at each sensing iteration. The SN is defined as follows,

$$SN \stackrel{\text{def}}{=} sl \left[ \nu_{n_{SN}} * \left( \prod_{m \in M} Q_m \mid T \mid P \right) \mid R_{SN} \right] \quad (3.31)$$

where  $P$  is the process which implements the SS and reporting functionality of the SN.  $Q_m$  is the process which deals with LDDF and KBU of the  $m^{\text{th}}$  channel.  $T$  is the process on which the NS occurs and  $R_{SN}$  comprises the node remaining functionality that is out of scope.

### 3.6.1 Spectrum Sensing

The SS and reporting functionality is given by the process  $P$ , which is divided in three subprocesses, defined as follows,

$$P \stackrel{\text{def}}{=} P_1 | P_2 | P_3 \quad (3.32)$$

$P_1$  is the subprocess which receives the information about which channel should be sensed in the next sensing iteration, and is defined as follows,

$$P_1 \stackrel{\text{def}}{=} w(a).\bar{e}\langle a \rangle \quad (3.33)$$

where  $a$  is the label of the channel which should be sensed, and  $e$  the communication link to the SS subprocess.

$P_2$  is the subprocess where the SS occurs, and is defined as follows,

$$P_2 \stackrel{\text{def}}{=} e(a).\bar{f}\langle SS(a) \rangle \quad (3.34)$$

where  $SS$  is the SS function, and  $f$  is the communication link with the reporting process. The output of the SS function is a local decision about the state of the sensed channel.

$P_3$  is the subprocess where the local decision is sent for processing in the  $Q$  process as well to be reported to the network, and is defined as

$$P_3 \stackrel{\text{def}}{=} f(b).\bar{v}\langle b \rangle.\bar{cc}\langle (n_{SN}, b) \rangle \quad (3.35)$$

where the  $v$  is the link with the  $Q$  process and  $cc$  is the CCH.

### 3.6.2 Data Fusion and Knowledge Base Update

The  $Q_m$  is the process where the state estimation of the  $m^{\text{th}}$  channel is performed. This process has the same structure as the  $Q_m$  in 3.5.2.

The  $Q_m$  process is defined by,

$$Q_m \stackrel{\text{def}}{=} Q_{m1} | Q_{m2} | Q_{m3} + Q_{m4} \quad (3.36)$$

$Q_{m1}$  subprocess is where the information from the SNs is collected, and is defined as follows,

$$Q_{m1} \stackrel{\text{def}}{=} C_m(\emptyset) \quad (3.37)$$

Here  $C_m$  is defined as

$$C_m(l) \stackrel{\text{def}}{=} v(b).C_m(b :: l) + cc(\lambda(x, y)(x, y)) \text{ if } x \neq n_{SN} \text{ then } C_m(y :: l) + \overline{d_m}(l) \quad (3.38)$$

where  $b$  is the local decision of the SN and  $y$  is the local decision of the other SNs in the network,  $cc$  is the CCH,  $v$  is the link from where the local decision information come from and  $d$  is the to the  $Q_{m2}$  process. The collection of local decisions ends, when a given number of decisions is collected or when the collection time period ends.

The sub-processes  $Q_{m2}$ ,  $Q_{m3}$  and  $Q_{m4}$  have the same definitions as the ones given in 3.5.2.

### 3.6.3 Node Selection

The selection of the channel to sense in the next iteration is implemented by the process  $T$ . This process follows the same structure as the  $T$  defined in 3.5.3.  $T$  is defined as,

$$T \stackrel{\text{def}}{=} T_1 \mid T_2 \quad (3.39)$$

The definition of the sub-process  $T_1$  is the same as in 3.5.3. While  $T_2$  is the subprocess through which the choice of channel to sense in the next iteration occurs, and is defined as,

$$T_2 \stackrel{\text{def}}{=} k(e).\overline{w}(NS(e)) \quad (3.40)$$

where the NS function this time selects which channel the SN should sense in the next sensing iteration.

## 3.7 Relay Based Topology Description

The network nodes in a relay based network topology can assume one of three roles, namely of SN, CN or of a RN. The SN is responsible for performing the

SS and is defined by

$$SN \stackrel{\text{def}}{=} sl[(\nu n_{SN}) * P \mid R_{SN}] \quad (3.41)$$

where  $P$  is the process which implements the sensing and reporting functionality at the SN and  $R_{SN}$  is its remaining node functionality which is out of scope. Similarly to the centralized topology, the SN performs the SS in every sensing iteration, except when it does not receive the information regarding which channel to sense from the CN. The definition of the process  $P$  is the same as the one presented in 3.5.1.

The RN is the node responsible for forwarding the data between the CN and SN, both in the uplink and downlink directions. The RN is defined as follows,

$$RN \stackrel{\text{def}}{=} rl[(\nu n_{RN}) * RC \mid R_{RN}] \quad (3.42)$$

where  $RC$  is the process which takes care of the messages relay from the SNs to the CN and in the reverse direction, i.e. from CN to the SNs, and  $R_{RN}$  represents any other node functionality which is out of scope in this paper.

The CN is responsible for the data fusion and the selection of which channels the sensing nodes should sense in the next sensing iteration. The CN is defined as follows,

$$CN \stackrel{\text{def}}{=} cl \left[ (\nu n_{CN}) * \left( \prod_{m \in M} Q_m \mid T \right) \mid R_{CN} \right] \quad (3.43)$$

where  $Q_m$  is the process which deals with data fusion and channel state estimation of the  $m^{\text{th}}$  channel.  $T$  is the process on which the choice of channel to sense in the next iteration occurs and finally  $R_{CN}$  represents any other node functionality which is out of scope in this paper. The definition of the processes  $Q_m$  and  $T$  are the ones presented in 3.5.2 and in 3.5.3 respectively.

### 3.7.1 Relay Process

The relay from the SN to the CN, or from CN to SN is done via the RN, and the process which allows this functionality in the RN is the  $RC$ , which allows relaying in the uplink and downlink directions. The  $RC$  process is defined as follows,

$$RC \stackrel{\text{def}}{=} R_1 \mid R_2 \quad (3.44)$$

The sub-process  $R_1$  collects the messages sent by the SNs or the CN and forwards them to sub-process  $R_2$ .

$$R_1 \stackrel{\text{def}}{=} CP([], []; f) \quad (3.45)$$

where  $CP(l_1, l_2; f)$  is a process that collects a pair of lists  $(l_1, l_2)$  of names and eventually outputs them on the  $f$  channel. This process is defined as

$$CP(l_1, l_2; f) \stackrel{\text{def}}{=} cc(\lambda(x, y)(x, y)).CP(x :: l_1, y :: l_2; f) + \bar{f}\langle l_1, l_2 \rangle \quad (3.46)$$

Here,  $x :: l$  denotes the list whose head is  $x$  and whose tail is  $l$ .

The sub-process  $R_2$  then sends the collected messages to the intended receiver.

$$R_2 \stackrel{\text{def}}{=} f(a, i).\bar{c}c\langle(a, i)\rangle \quad (3.47)$$

Note that it is implicit that the output of the  $R_2$  process does not feedback in the input of the  $R_1$  process.

## 3.8 Correctness

Protocol correctness is defined as the ability of the network protocol to allow the network nodes to perform the task to which they were designed for. In a CSS mechanism the protocol will be correct if it allows the network nodes to cooperate with each other, enabling the CSS. The protocol is considered to be correct only if the network nodes running that same protocol reach a resolved state periodically, which means that the CSS as occurred and will continue to do so infinitely often.

The network  $S$  is considered to reach a resolved state when the NS function is reached. The definition of resolved state is dependent on the network topology and therefore it will be given later in this section to each of the considered topologies.

To aid the readability of the proofs, the following notation definitions for reduction sequences are introduced. It allows one to express that a network  $S$  reaches another state  $S'$  after some number of steps.

**Definition 2.** If  $S \longrightarrow^* S'$  when  $n \geq 0$ , then one can write  $S \longrightarrow^n S'$ .

**Definition 3.** If  $S \longrightarrow^n S'$  with  $n > 0$ , then one can write  $S \longrightarrow^+ S'$ .

With these definitions it is now possible to express and prove correctness.

**Theorem 2.** *Let  $S$  be one of the following networks:*

- *Centralized:*

$$S \equiv (\nu\vec{c}\vec{c}) \left( \prod_{i \in I} cl \bowtie sl_i \right) | CN | \prod_{i \in I} SN_i \quad (3.48)$$

if  $|I| = n$ .

- *Decentralized:*

$$S \equiv (\nu\vec{c}\vec{c}) \left( \prod_{i,j \in I, i \neq j} sl_i \bowtie sl_j \right) | \prod_{i \in I} SN_i \quad (3.49)$$

if  $|I| = n$ .

- *Relay:*

$$S \equiv (\nu\vec{c}\vec{c}) \left( \prod_{j \in J} cl \bowtie rl_j | \prod_{j \in J} \prod_{i \in I_j} sl_i \bowtie rl_j \right) | CN | \prod_{j \in J} RN_j | \prod_{i \in \bigcup_{j \in J} I_j} SN_i \quad (3.50)$$

if  $|\bigcup_{j \in J} I_j| = |I|$ ,  $|J| > 0$ ,  $|I| > 0$  and  $n = |J| + |I|$ .

Then  $S$  satisfies the following:

1.  $S \longrightarrow^* S'$  where  $S'$  is resolved
2. for any  $S'$  where  $S \longrightarrow^* S'$  and  $S'$  resolved.  $\exists S''$  such that  $S' \longrightarrow^+ S''$ ,  $S''$  is resolved.

*Proof.* Here is given a sketch of the proof, which proceeds by induction in the number of non-central nodes, i.e. SNs and RNs when applicable.

### 3.8.1 The Centralized Case

Here, the procedure is to perform induction in  $n = |I|$ . The definition of resolved state in the centralized topology is given by,

**Definition 4.**  $S$  is resolved if  $S \equiv S' | cl [\bar{c}\bar{c}\langle n_{CN}, NS(c) \rangle]$  for some  $n_{CN}$  and  $c$ .

The first step of the proof in the centralized topology is to show that in the base case, i.e. when  $n = 1$ , the network reduces from its initial state after a number of reduction steps to the resolved case, proving the first item of the theorem.

The first step of the proof is to resolve the  $S$  structure when  $|I| = 1$ . The  $S$  structure in this case reduces as

$$S \equiv \underbrace{(\nu\bar{c}\bar{c}) (cl \bowtie sl)}_{S^I} | CN | SN \quad (3.51)$$

And the sequence of reductions follows,

$$S^I | SN | CN \longrightarrow^* \underbrace{S^I | SN | CN | \bar{c}\bar{c}\langle n_{CN}, NS(c) \rangle}_{\text{Resolved State}} \quad (3.52)$$

The second item of the theorem states that when the network achieves the resolved state, it can achieve it again after a number of reduction steps. This can be proved with the following sequence of reductions,

$$\underbrace{S^I | SN | CN | \bar{c}\bar{c}\langle n_{CN}, NS(c) \rangle}_{\text{Resolved State}} \longrightarrow^+ \underbrace{S^I | SN | CN | \bar{c}\bar{c}\langle n_{CN}, NS(c) \rangle}_{\text{Resolved State}} \quad (3.53)$$

So with this it is proved that the base case accomplishes both items of the theorem.

Following the induction hypothesis it can be assumed that the case where  $|I| = N$ ,  $S$  reaches the resolved state, and so to complete the proof the final is to show what happens when an extra SN is added to the network, i.e. the number of nodes in the network is  $|I| = N + 1$ . Therefore the network as the following form,

$$S \equiv \underbrace{(\nu\bar{c}\bar{c}) \left( \prod_{i \in I} cl \bowtie sl_i \right)}_{S^I} | CN | \prod_{i \in I} SN_i$$

The flow of the proof is the same as in the base case, i.e. first show that the first item of the proof occurs and finish the proof by showing that the second item also occurs. The full proof is shown in Appendix A.

### 3.8.2 The Decentralized Case

Again, the procedure is to perform induction in  $n = |I|$ . The definition of resolved state in the decentralized topology is given by,

**Definition 5.**  $S$  is resolved if  $S \equiv S' | \prod_{i \in I} sl_i [\bar{w}_i \langle NS(c) \rangle]$  for some  $c$ .

Following the same logic as the centralized topology, first is shown that  $S$  resolves when  $|I| = 2$ , where there are two nodes and therefore a network can be formed.

The  $S$  structure in this case reduces as

$$S \equiv \underbrace{(\nu \bar{c} \bar{c}) (sl_1 \bowtie sl_2)}_{S^I} | SN_1 | SN_2 \quad (3.54)$$

And the sequence of reductions follows,

$$S^I | SN_1 | SN_2 \longrightarrow^* \underbrace{S^{II} | \bar{w}_1 \langle NS(c) \rangle | P^1 | \bar{w}_2 \langle NS(c) \rangle | P^2}_{ResolvedState} \quad (3.55)$$

The second item of the theorem states that when the network achieves the resolved state, it can achieve it again after a number of reduction steps. This can be proved with the following sequence of reductions,

$$\underbrace{S^{II} | \bar{w}_1 \langle NS(c) \rangle | P^1 | \bar{w}_2 \langle NS(c) \rangle | P^2}_{ResolvedState} \longrightarrow^+ \quad (3.56)$$

$$\underbrace{S^{II} | \bar{w}_1 \langle NS(c) \rangle | P^1 | \bar{w}_2 \langle NS(c) \rangle | P^2}_{ResolvedState} \quad (3.57)$$

Following the induction hypothesis it can be assumed that the case where  $|I| = N$ ,  $S$  reaches the resolved state, and so to complete the proof the final step is to show what happens when an extra SN is added to the network, i.e. the number of nodes in the network is  $|I| = N + 1$ . The  $S$  structure in this case is defined as,

$$S \equiv (\nu \bar{c} \bar{c}) \left( \prod_{i,j \in I, i \neq j} sl_i \bowtie sl_j \right) | \prod_{i \in I} SN_i$$



The flow of the proof is the same as in the base case, i.e. first show that the first item of the proof occurs and finish the proof by showing that the second item also occurs. The full proof is shown in Appendix B.

### 3.8.3 The Relay Case

The induction is performed in  $n = |J| + |I|$ . The definition of resolved state in the relay assisted topology is given by,

**Definition 6.**  $S$  is resolved if  $S \equiv S' | cl [\overline{cc}\langle n_{CN}, NS(c) \rangle]$  for some  $n_{CN}$  and  $c$ .

Following the same logic as the centralized topology, first the  $S$  is resolved for the base case, which in this topology occurs when  $n = 2$ , the minimum size of the network. The network topology in this case is given by,

$$S \equiv \underbrace{(\nu\vec{c}\vec{c}) (sl \bowtie rl | cl \bowtie rl)}_{S^I} | SN | RN | CN$$

To simplify the notation, in the base case the index of the  $SN$  and the  $RN$  are not included since there is only one of each. So first the steps from the initial state until the resolved state are computed.

$$\underbrace{S^I | SN | RN | CN}_{S^{II}} \longrightarrow^* \underbrace{S^{II} | \overline{cc}\langle (n_{CN}, NS(c)) \rangle | CN}_{\text{Resolved State}}$$

The second item of the theorem states that when the network achieves the resolved state, it can achieve it again after a number of reduction steps. This can be proofed with the following sequence of reductions,

$$\underbrace{S^{II} | \overline{cc}\langle (n_{CN}, NS(c)) \rangle | CN}_{\text{Resolved State}} \longrightarrow^+ \underbrace{S^{II} | \overline{cc}\langle (n_{CN}, NS(c)) \rangle | CN}_{\text{Resolved State}}$$

Following the induction hypothesis it is assumed that the case where  $|I| + |J| = n = N$ ,  $S$  reaches the resolved state, and so to complete the proof it is shown what happens when  $n = N + 1$ .

So assuming by induction hypothesis that for all  $n' < n$ ,  $S$  reaches a resolved state. Then it can be shown that for  $n$  the network  $S$  can also reach a resolved state. To perform the proof, due the network topology, there are the following two subcases:

1. Induction in the size of  $|J|$ , when  $|I| = 1$ . The case  $|J| = 1$  is the same as the base case, so the case  $|J| > 1$  needs to be proved by induction hypothesis;
2. Induction in the size of  $|I|$ , when  $|J| > 1$ . This is only possible after the first sub-case has been proved.

The full proof is shown in Appendix C.

□

## 3.9 Conclusions

In this chapter a PC, denoted as BBC, was introduced to describe and reason about the computational properties of distributed protocols which enable CSS. The BBC uses broadcast communication over channels with bounded capacity to allow a more realistic modelling of the CSS.

Three different network topologies were considered – centralized, decentralized and relay based topologies – and their associated CSS protocols. In each case it is straightforward to describe conditions for protocol correctness that ensure that the agents participating in the cooperative scheme will eventually reach a resolved state every time a SS round is initiated. A theorem on the correctness of the protocols was given and proved by standard inductive proof techniques.

The work shows that process calculi provide a promising approach for describing and reasoning about the computational properties wireless communication protocols. The proofs in this chapter were done by hand; a topic for further work is to mechanize the proofs using a verification tool such as ProVerif [2] or a proof assistant. The use of this methodology will streamline the application of the BBC and its variants to other distributed protocols scenarios. In the literature there can be found several examples of when ProVerif has been used to automatize the proofs, one such example is Godskesen’s formal verification of the ARAN routing protocol using the applied  $\pi$ -calculus, [4].

## References

- [1] Francesco Ballardin and Massimo Merro. A calculus for the analysis of wireless network security protocols. In Pierpaolo Degano, Sandro

- 
- Etalle, and Joshua D. Guttman, editors, *Formal Aspects in Security and Trust*, volume 6561 of *Lecture Notes in Computer Science*, pages 206–222. Springer, 2010.
- [2] B. Blanchet. Automatic verification of correspondences for security protocols. *Journal of Computer Security*, 17(4):363–434, July 2009.
- [3] Cristian Ene and Traian Muntean. A broadcast-based calculus for communicating systems. In *Proceedings of IPDPS'1*, pages 149–, Washington, DC, USA, 2001. IEEE Computer Society.
- [4] J. C. Godskesen. Formal verification of the aran protocol using the applied pi-calculus. In *Proceedings of the Sixth International IFIP WG 1.7 Workshop on Issues in the Theory of Security*, pages 99–113, 2006.
- [5] J. C. Godskesen, H. Hüttel, and M. Kühnrich. Verification of correspondence assertions in a calculus for mobile ad hoc networks. *Electronic Notes Theory Computer Science*, 229(2):77–93, 2009.
- [6] M. Hennessy. *A distributed Pi-calculus*. Cambridge University Press, 2007.
- [7] P. Janacik, E. Mathews, and D. Orfanus. Self-organizing data collection in wireless sensor networks. In *AINA Workshops*, pages 662–667. IEEE Computer Society, 2010.
- [8] Robin Milner. *A Calculus of Communicating Systems*, volume 92 of *Lecture Notes in Computer Science*. Springer, 1980.
- [9] Robin Milner, Joachim Parrow, and David Walker. A calculus of mobile processes, i. *Inf. Comput.*, 100(1):1–40, 1992.
- [10] Robin Milner, Joachim Parrow, and David Walker. A calculus of mobile processes, ii. *Inf. Comput.*, 100(1):41–77, 1992.
- [11] Sebastian Nanz and Chris Hankin. A framework for security analysis of mobile wireless networks. *Theor. Comput. Sci.*, 367:203–227, November 2006.
- [12] N. Pratas, N. Marchetti, N. R. Prasad, A. Rodrigues, and R. Prasad. Decentralized cooperative spectrum sensing for ad-hoc disaster relief network clusters. In *IEEE 71st Vehicular Technology Conference (VTC 2010-Spring)*, pages 1 –5, May 2010.

- [13] N. Pratas, N. Marchetti, N.R. Prasad, A. Rodrigues, and R. Prasad. Centralized cooperative spectrum sensing for ad-hoc disaster relief network clusters. In *IEEE International Conference on Communications (ICC 2010)*, pages 1–5, May 2010.
- [14] James Riely and Matthew Hennessy. A typed language for distributed mobile processes (extended abstract). In *POPL*, pages 378–390, 1998.



# 4

## Data Fusion of Local Spectrum Sensing Decisions

### 4.1 Introduction

In Figure 4.1 is depicted the flow which serves as basis for the Cooperative Spectrum Sensing (CSS) mechanism considered in this thesis. The purpose of the CSS mechanism, as discussed in the previous chapters, is to ensure that all Cognitive Radio Network (CRN) nodes have updated and synchronized information about the state of the monitored spectrum. The function of each of the modules depicted in the flow is the following:

- Spectrum Sensing - Each CRN node uses a local detector to perform the spectrum sensing and reach a local decision regarding the status of the sensed channel, i.e. if either the channel is vacant or not, as discussed in Chapter 1 and in Chapter 2;
- Local Decision Reporting - Each CRN node shares the local decisions with the rest of the network, where the intended recipients depend on the considered network topology, as discussed in Chapter 3;
- Local Decisions Fusion - Here the recipient nodes perform the data fusion using the local decisions received from the CRN nodes. As discussed

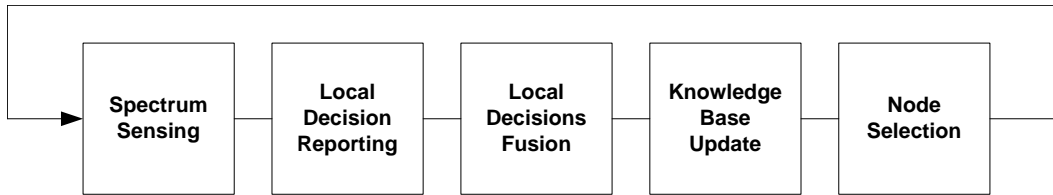

Figure 4.1: Distributed cooperative spectrum sensing flow

in Chapter 3 in a multi-channel sensing scenario the data fusion is performed separately for each sensed channel;

- Knowledge Base Update - Here the CRN combines the reached global decision in the previous step with the past decisions so to create a continuous knowledge base, which can then be used by the network for deciding which resources to use, as discussed in Chapter 2;
- Node Selection - Finally in this step the network chooses which channel should each of the CRN nodes sense, as discussed in Chapter 5.

The focus in this chapter is on the *Local Decisions Fusion* step. From a structural standpoint the Local Decisions Data Fusion (LDDF) system can be classified as a two level parallel distributed detection system, as depicted in Figure 4.2, consisting of an arbitrary number of local detectors and a fusion center. Each CRN node, here denoted as a Local Detector (LD), reaches a local decision based on the underlying hypothesis testing problem. The local decisions are then transmitted to the fusion center where a global decision is made, as depicted in Figure 4.1.

Through the LDDF process it is possible to achieve a global decision by combining together the local decisions. The type of data fusion depends on the amount of information available from each local decision. Where this amount of information is in general limited by the reporting channel bandwidth, as discussed in Chapter 2. Here is considered the synchronous hard combining class of data fusion, which employs fusion rules to achieve the data fusion. Where a fusion rule is a logical function with  $c$  binary inputs and one binary output, also called boolean function; therefore there are  $2^{2^c}$  possible fusion rules when there are  $c$  binary inputs to the fusion centre. From these there are a subset which are classified as counting rules, i.e. they count the number of local decisions stating a given state and then compare it with a decision threshold to reach a decision about the state of the channel. The selection of the threshold affects both the global probability of false alarm as well as the global probability of detection.

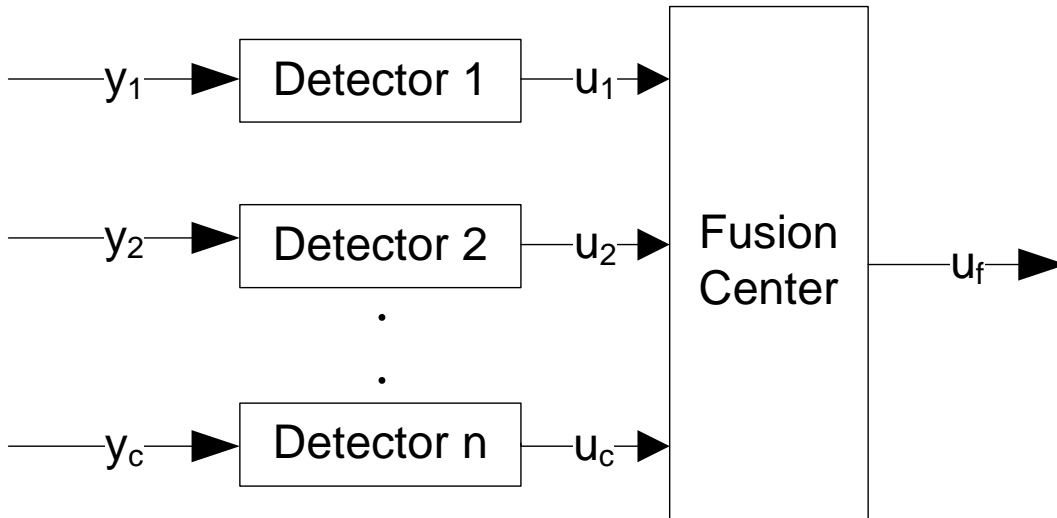

Figure 4.2: Two-level distributed detection system

## 4.2 Motivation for the use of Counting Rules

Spectrum sensing is in essence a detection problem, where the purpose is to find what is the state of the monitored channel, i.e. if the channel is vacant or not. Being a detection problem it can be modelled as a statistical hypothesis testing problem. Here is considered the binary hypothesis testing both at the LD level and at Fusion Center (FuC) level, although other other methods can be applied, such as composite hypothesis and sequential testing methods, [1].

The detection problem at the local detectors can be formulated as a test of two hypothesis, given by,

$$y_i = \begin{cases} w_i & \text{if } H_0 \\ s_i + w_i & \text{if } H_1 \end{cases} \quad i = 1, \dots, N \quad (4.1)$$

where  $y_i$  is the received signal  $i^{\text{th}}$  sample at the detector,  $s_i$  is the  $i^{\text{th}}$  sample of the signal or in the case where there are several signals the cummulation of those signals, and  $w_i$  is the  $i^{\text{th}}$  sample of the additive white gaussian noise.  $H_0$  and  $H_1$  denote the hypothesis corresponding to the absence and presence of a signal. The detector from the observation of  $y(t)$  decides between  $H_0$  and  $H_1$ . The  $j^{\text{th}}$  detector performs the hypothesis testing over  $N$  samples of the received signal and reaches a conclusion regarding the state of the spectrum, denoted as  $u_j$ , as depicted in Figure 4.2.



From hypothesis testing at the  $j^{\text{th}}$  local detector the Likelihood Ratio Test (LRT) can be formulated following the Neyman-Pearson (NP) test formulation. The objective of the NP test is to maximize the local detection probability,  $p_d$ , given a constraint on the local probability of false alarm  $p_{fa}$ , i.e.  $p_{fa} \leq \alpha$ . So it can be shown, [10], that the NP test,  $\Lambda(u_j)$ , is equivalent to the LRT given by,

$$\Lambda(u_j) = \frac{P(y_1, \dots, y_N | H_1)}{P(y_1, \dots, y_N | H_0)} \underset{>_{H_0}}{\overset{\leq_{H_1}}{\lambda}} \quad (4.2)$$

The FuC performs the data fusion over the local decisions communicated to it by the local detectors, and is referred here as LDDF. The LDDF process is modelled also as a NP test,  $\Lambda(\mathbf{u})$ , which is formulated by the following LRT,

$$\Lambda(\mathbf{u}) = \frac{P(u_1, u_2, \dots, u_c | H_1)}{P(u_1, u_2, \dots, u_c | H_0)} \underset{>_{H_0}}{\overset{\leq_{H_1}}{\lambda}} \quad (4.3)$$

where  $\mathbf{u} = [u_1, \dots, u_c]^T$ , is the vector formed by the set of local decisions (where  $u_i = 0$  when the sensor  $i$  decides  $H_0$ , and  $u_i = 1$  when the sensor  $i$  decides  $H_1$ ) corresponding to the  $c$  local detectors and  $\lambda$  is the decision threshold.  $\lambda$  is computed by setting an upper bound on the local probability of false alarm at the FuC [10].

Now, consider the case where all the detectors have the same performance, i.e. they have the same local probability of detection,  $p_d$ , and local probability of false alarm,  $p_{fa}$ , and that there is a quantifiable degree of correlation between their decisions, i.e. there is a statistical relation between the local detectors decisions over time such that systematic changes in the value of one of the local detectors decisions will be accompanied by systematic changes in the other local detectors decisions. Then, according to [4], the LRT can be expressed as,

$$\Lambda(\mathbf{u}) = \frac{P(\mathbf{u} | H_1)}{P(\mathbf{u} | H_0)} = \Lambda(m) \quad (4.4)$$

where  $m$  out of  $c$  detectors are in favor of  $H_0$  (i.e. there are  $m$  zeros in the vector  $\mathbf{u}$ ). Elaborating further  $\Lambda(\mathbf{u})$  [11],

$$\Lambda(\mathbf{u}) = \frac{\sum_{i=0}^m (-1)^i \binom{m}{i} p_d \prod_{k=0}^{c-m+i-2} \frac{\rho_1(k+1-p_d)+p_d}{1+k\rho_1}}{\sum_{i=0}^m (-1)^i \binom{m}{i} p_{fa} \prod_{k=0}^{c-m+i-2} \frac{\rho_0(k+1-p_{fa})+p_{fa}}{1+k\rho_0}}, 0 \leq m \leq c-2 \quad (4.5)$$

where  $p_d$  and  $p_{fa}$ , are respectively the local probability of detection and local probability of false alarm, and the correlation coefficients  $0 \leq \rho_0 \leq 1$  and

$0 \leq \rho_1 \leq 1$ . Although in [4],  $\Lambda(\mathbf{u})$  was not explicitly considered for the cases when  $m = c - 1$  and  $m = c$ , it was considered and derived in [11].

The optimum decision rule, i.e. the one which maximizes the global probability of detection,  $GP_d$ , for a given upper bound of the global probability of false alarm,  $GP_{fa}$ , is obtained by the LRT given by,

$$rule_{optimal}(\mathbf{u}) = rule_{optimal}(\mathbf{m}) = \quad (4.6)$$

$$\begin{cases} H_1 & , \text{ if } \Lambda(m) > \lambda \\ H_1 \text{ with probability } \gamma & , \text{ if } \Lambda(m) = \lambda \\ H_0 & , \text{ if } \Lambda(m) < \lambda \end{cases} \quad (4.7)$$

where  $\gamma$  is a randomization constant. Both  $\lambda$  and  $\gamma$  are greater than zero, and are defined by the upper bound of  $GP_{fa}$ .

The implementation of the LRT can lead to complex iterative algorithms. Therefore, in [4] it was shown that the LRT can also be expressed as a function of  $m$ , i.e. the number of detectors that decide in favor of  $H_0$ . In [11] it was proposed to use a counting rule instead of a LRT, i.e. a rule that counts  $m$ , and decide  $H_1$  when  $m$  is smaller than a given integer threshold,  $m_0$ . This counting rule can be defined as,

$$rule_{count}(\mathbf{u}) = rule_{count}(\mathbf{m}) = \quad (4.8)$$

$$\begin{cases} H_1 & , \text{ if } m < m_0 \\ H_1 \text{ with probability } \gamma & , \text{ if } m = m_0 \\ H_0 & , \text{ if } m > m_0 \end{cases} \quad (4.9)$$

The equivalence between the LRT and the counting rule is then given by,

$$\Lambda(m) \lesseqgtr \lambda \Leftrightarrow m \lesseqgtr m_0(\lambda) \quad (4.10)$$

and is only valid if  $\Lambda(m)$  is a decreasing function of  $m$ , as demonstrated in [11].

The conclusion taken from the analysis on both [4, 11] is that the choice of the counting rule threshold,  $k$ , depends on the Local Detectors (LDs) performance, the correlation between the decisions of the detectors, and finally on the upper bound set for the  $GP_{fa}$ .

A counting rule belongs to a subset of the fusion rule set. Where a fusion rule, as discussed previously, is a logical function with  $c$  binary inputs and one binary output. From  $c$  binary inputs there are  $2^{2^c}$  possible fusion rules. From this set of possible fusion rules only a subset of those are of interest, since a large majority of the fusion rules can disregard some or in some cases all of the inputs. A discussion on how to obtain the set of fusion rules of interest in a data fusion context can be found in [10].

In the remaining of thesis is assumed that the LDDF is always accomplished through counting rules.

### 4.3 Counting Rules Theoretical Formulation

In [4], as discussed in the previous section, was analyzed the effect of correlation in the performance of LDDF when the LDs are experiencing the same level of correlation. One of the conclusions, besides that LDDF can also be accomplished through counting rules, was that the higher the correlation between the LDs then the lower was the performance gain obtained from performing data fusion. This occurs because as the correlation increases the decisions of the LDs become similar, therefore there is less information for the FuC to work with. In the limit, when the correlation coefficient is 1, the performance of the data fusion becomes the same as the one from the LD. In [4] it was not considered the scenario where the correlation between the decisions of the LDs is not the same, i.e. if one would measure the correlation between the decisions of different pairs of LDs then one would obtain different correlation coefficients, and also it did not consider the case where the correlation under  $H_0$  and  $H_1$  are different.

In the case of cooperative spectrum sensing, the LDs are uncorrelated in regard to  $H_0$ , since the noise at each LD is independent from the noise at the other LDs. So although experiencing the same conditions, the LDs, can still generate a false alarm independently of each other. This occurs because although the LDs are experiencing the same average power level due to noise, the detection process is still independent since the input samples vector,  $\mathbf{y}$ , are independent at each of the LDs.

When the signal is present,  $H_1$ , the signal power amplitude variation will be correlated both in space and in time due to fast fading as well as to slow fading. The signal samples received by two LDs will be uncorrelated if these local detectors are at least separated by half of the wavelength of the signal carrier [5]. Therefore, under  $H_1$  the LDs are also uncorrelated. The slow fading or shadowing makes the signal power amplitude to be correlated over distances that can span tens of meters or more, depending of the surrounding radio environment. So it is likely that the power levels experienced by the LDs will be correlated with each other, this correlation in the power will not affect the independence between the detections at the local detectors, instead impacting on the detection performance of the local detector.

The LDs are designed to achieve a certain local probability of detection,  $p_d$ , at a specific  $SNR$  target while having a constant local probability of false alarm,  $p_{fa}$ . So when the  $SNR$  experienced by the acLD varies then the LD actual  $p_d$  will also vary. Therefore, although the detections at the LDs will still be independent, the actual  $p_d$  is no longer the same among all the LDs. The spread of the  $p_d$  will be dependent upon the correlation between the signal power received at each of the LDs, so it is expected that for the LDs which are near each other the received signal power will be nearly the same, while others that are farther apart will have more differentiated received signal power levels. Before analysing the performance of the LDDF while using local decisions from LDs with different  $p_d$ , first it is considered the case where the LDs are independent and identical distributed and the LDs are experiencing the same  $SNR$  level, i.e. all the LDs have the same  $p_d$ . From there it is derived the global probability of detection and false alarm,  $GP_d$  and  $GP_{fa}$  respectively.

The performance of the data fusion process based on counting rules is characterized by the global probability of detection,  $GP_d(k, c)$ , and false alarm,  $GP_{fa}(k, c)$ , which are derived as follows. The probability that there are exactly  $k$  independent and identical distributed LDs out of  $c$  LDs, that perform a given event  $x$  follows a binomial distribution with parameters  $c$  and  $p_x$  and is given by,

$$Pr(\text{exactly } k \text{ events } x \text{ out of } c \text{ local detectors}) = \binom{c}{k} p_x^k (1 - p_x)^{c-k} \quad (4.11)$$

The  $k$  is the decision threshold, following the definition in the previous section, defined as  $k = c - m_0$ . Defining  $GP_x(k, c)$  as the global probability of an event  $x$  occurring in at least  $k$  out of  $c$  local detectors, and where the probability of that same event  $x$  occurring at any local detector is given by  $p_x$ , then,

$$GP_x(k, c) = \sum_{i=k}^c \binom{c}{i} p_x^i (1 - p_x)^{c-i} \quad (4.12)$$

Considering that the event  $x$  can either be a detection or a false alarm, also known as false detection, then the  $GP_d(k, c)$  and  $GP_{fa}(k, c)$ , for an arbitrary counting rule threshold  $k$  where the local detectors are i.i.d., are defined as,

$$GP_d(k, c) = \sum_{i=k}^c \binom{c}{i} p_d^i (1 - p_d)^{c-i} \quad (4.13)$$

and

$$GP_{fa}(k, c) = \sum_{i=k}^c \binom{c}{i} p_{fa}^i (1 - p_{fa})^{c-i} \quad (4.14)$$

where  $k$  is the threshold of the counting rule, i.e.  $k$ -out-of- $c$ .  $p_d$  and  $p_{fa}$  are respectively the local detectors probability of detection and false alarm, which substitute  $p_x$  in the previous equation.

Next is analyzed the sensitivity of  $GP_x(k, c)$  to the variation of  $k$ ,  $c$  and  $p_x$ . The methodology followed in this analysis mirrors the one presented in [6] for the analysis of the reliability of a  $k$ -out-of- $n$  system with i.i.d. components.

Now to analyse how the  $GP_x(k, c)$  varies with  $c$  while considering a fixed  $k$  and  $p_x$ . First a pivotal decomposition method developed in [7] and illustrated in [6] is applied to the  $GP_x(k, c)$ ,

$$\begin{aligned}
 GP_x(k, c) &= p_x GP_x(k-1, c-1) + (1-p_x) GP_x(k, c-1) \\
 &= p_x (GP_x(k-1, c-1) - GP_x(k, c-1)) + GP_x(k, c-1) \\
 &= p_x Pr(k-1 \text{ detections out of } c-1 \text{ components}) + GP_x(k, c-1) \\
 &= \binom{c-1}{k-1} p_x^k (1-p_x)^{c-k} + GP_x(k, c-1)
 \end{aligned} \tag{4.15}$$

Then by rearranging the equation it is possible to obtain the growth rate,  $mC$ , of  $GP_x$  with  $c$  which is given by,

$$mC = GP_x(k, c) - GP_x(k, c-1) = \binom{c-1}{k-1} p_x^k (1-p_x)^{c-k}, \text{ for } c \geq k \tag{4.16}$$

Now consider the plot in Figure 4.3 where the sensitivity of  $GP_x(k, c)$  to the increase of the number of local detectors  $c$  is depicted. From the figure it can be seen that after a certain threshold, in this case when  $c = 18$ , the growth of the  $GP_x$  decreases. So this leads to the conclusion that increasing the number of local detectors participating in the data fusion process only makes sense up to a certain point, which depends of course on the considered  $k$  and  $p_x$ . Now considering the boundary condition  $GP_x(k, c) = 0$  when  $c < k$  then  $GP_x(k, c)$  can be redefined as,

$$GP_x(k, c) = \sum_{i=k}^n [GP_x(k, c) - GP(k_x, c-1)] = p_x^k \sum_{i=k}^c \binom{i-1}{k-1} (1-p_x)^{i-k} \tag{4.17}$$

From this equation it can be seen that  $GP_x(k, c)$  increases with  $c$  and  $p_x$  and decreases with  $k$ .

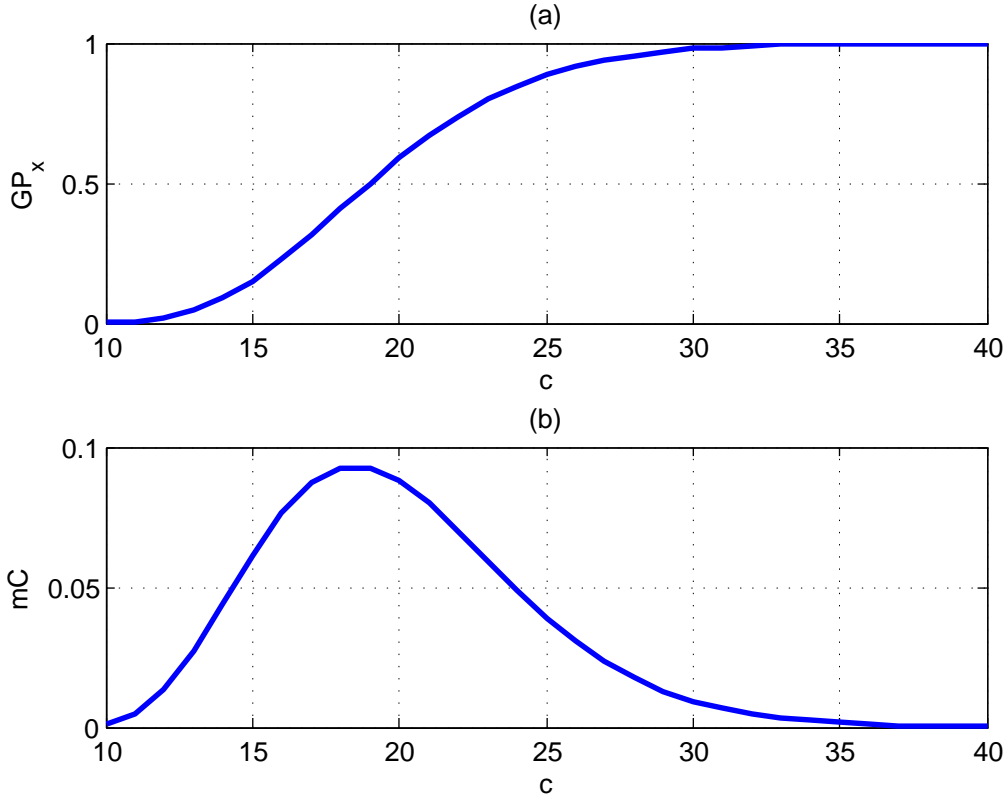

Figure 4.3: (a,b)  $GP_x$  and  $mC$  variation with  $c$ , where  $k = 10$  and  $p_x = 0.5$

Now to analyse how the  $GP_x(k, c)$  varies with  $k$  while considering a fixed  $c$  and  $p_x$ .

$$\begin{aligned}
 GP(k, c) &= Pr(\text{at least } k \text{ detections}) \\
 &= Pr(\text{at least } k - 1 \text{ detections}) - Pr(\text{exactly } k - 1 \text{ detections}) \\
 &= GP(k - 1, c) - \binom{c}{k-1} p^{k-1} q^{c-k+1}
 \end{aligned} \tag{4.18}$$

Then by rearranging the equation the following is obtained,

$$mK = GP(k - 1, c) - GP(k, c) = \binom{c}{k-1} p^{k-1} (1 - p)^{c-k+1} \tag{4.19}$$

Now consider the plot in Figure 4.4 where the sensitivity of  $GP_x(k, c)$  to the increase of the  $k$  threshold is depicted. From the plot it can be seen that  $GP_x(k, c)$  decreases with the increase of  $k$ , and also that the growth of  $GP_x(k, c)$

reaches a minimum when  $k = 20$ . This leads to the conclusion that the  $k$  threshold can be increased without a significant impact on the  $GP_x(k, c)$  until a certain point, which depends on  $c$  and  $p_x$ .

Finally, to analyse how the  $GP_x(k, c)$  varies with  $p_x$  while considering a fixed  $c$  and  $k$ ,  $GP_x(k, c)$  is differentiated in regards to  $p_x$ , as given

$$mP_x = \frac{d}{dp_x} GP_x(k, c) = k \binom{c}{k} p^{k-1} (1-p)^{c-k} \quad (4.20)$$

In the Figure 4.5 is plotted  $GP_x(k, c)$  in regards to the variation with  $p_x$ . As expected,  $GP_x(k, c)$  increases with  $p_x$  and as with the other variables after a certain value of  $p_x$  the increase in  $GP_x(k, c)$  is negligible.

## 4.4 Performance Evaluation Metrics

The goal of Spectrum Sensing (SS) is to detect what is the state of the range of spectrum being monitored. This process can be described as a mechanism which corresponds to an imperfect and simplified mapping of the real radio environment conditions, to a representation in the CRN nodes, as depicted in Figure 4.6.

The considered LDDF method can be classified as a binary classification problem, since its purpose is to determine whether the monitored channel is occupied or not. Therefore its performance can be presented in the form of a confusion matrix, as depicted in Figure 4.7, which includes the True Positives (TP), False Positives (FP), False Negatives (FN) and True Negatives (TN) accumulators. This matrix can be obtained after running a training sequence, where the actual state of the channel is known, i.e. it is known whether a signal is present,  $H_1$ , or not,  $H_0$ , and then the TP, FP, FN and TN can be determined accordingly.

In the considered context there are several LDs, spread across space, that participate in the data fusion process, among these there might be some which the signal at their spatial location is experiencing a deep fade, which makes the signal strength to be below the detection target threshold, and therefore their actual state is  $H_0$ . This effect, due to spatial diversity, is accounted for in the analysis of the data fusion process performance by considering that the actual state in the fusion center is  $H_1$ , if at least at the location of one of the local detectors the actual state is also  $H_1$ , which is in-line with the aim of cooperative spectrum sensing. This assumption will be in place until otherwise stated.

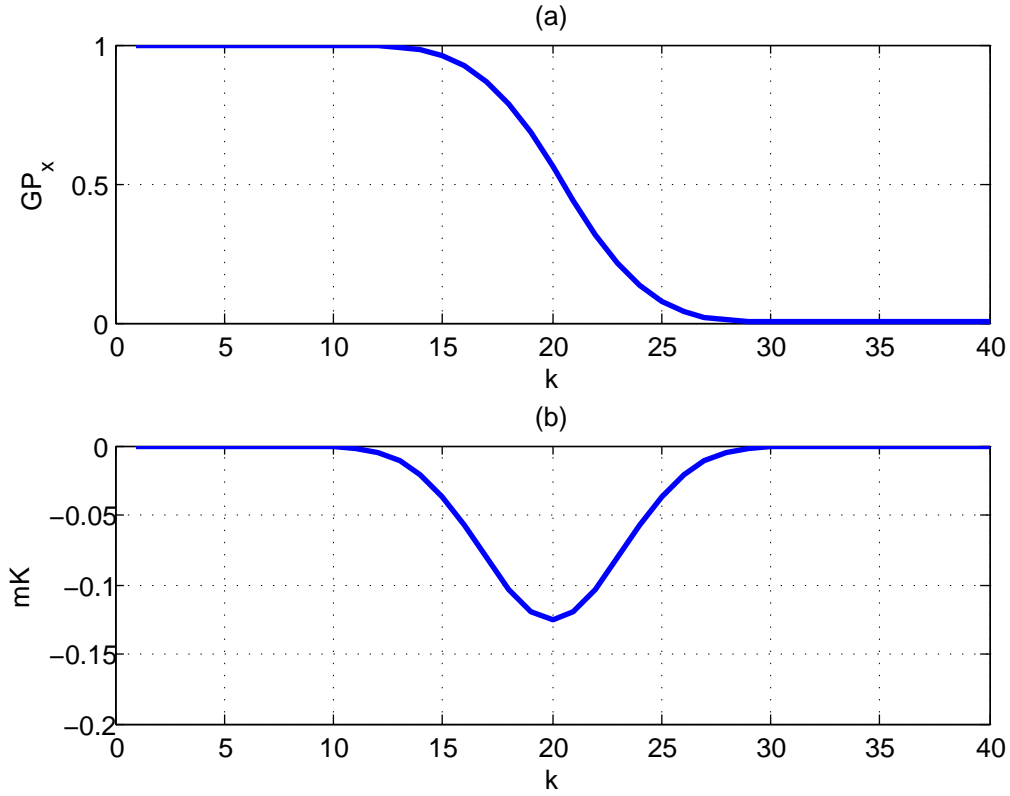

Figure 4.4: (a,b)  $GP_x$  and  $mK$  variation with  $K$ , where  $c = 40$  and  $p_x = 0.5$

Now considering the case where the confusion matrix, depicted in Figure 4.7, is filled with the experimental data, which can be obtained from a simulation or from an actual experiment, then the  $GP_d$  and  $GP_{fa}$  can be obtained from the data in the matrix using the following equations,

$$GP_d = \frac{TP}{TP + FN} \quad (4.21)$$

$$GP_{fa} = \frac{FP}{FP + TN} \quad (4.22)$$

With that in mind it is possible to define two different performance measurement metrics, the Matthews correlation coefficient [3],  $\phi$ , and the Root Mean Square Error,  $\epsilon$ . First it is defined the  $\phi$  coefficient. The data fusion process performance can be measured through the  $\phi$  coefficient, which is defined as,

$$\phi = \frac{TP \times TN - FP \times FN}{\sqrt{(TP + FP)(TP + FN)(TN + FP)(TN + FN)}} \quad (4.23)$$



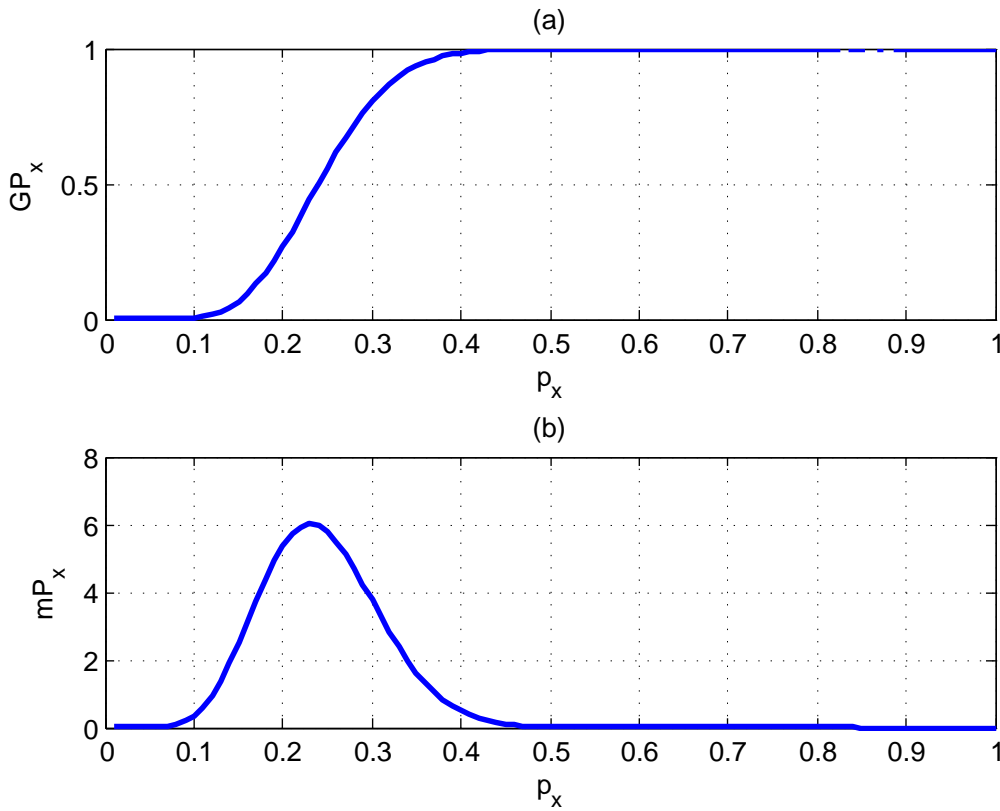

Figure 4.5: (a,b)  $GP_x$  and  $mP$  variation with  $p_x$ , where  $c = 40$  and  $k = 10$

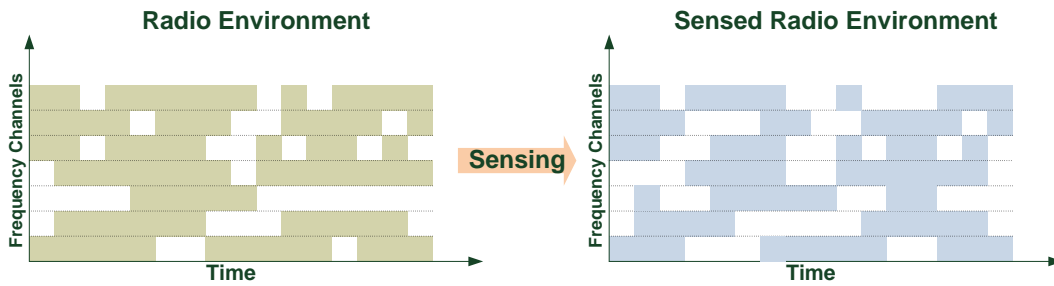

Figure 4.6: Representation of sensing from a cognitive radio perspective.

The  $\phi$  measures the correlation between the observed and the predicted binary classification, and it returns a value between  $-1$  and  $+1$ . When  $\phi = +1$  it means there was a perfect prediction, when  $\phi = 0$  there is an average random prediction with the same performance as tossing a coin, finally when  $\phi = -1$  there is the inverse prediction.

		Actual		
		$H_1$	$H_0$	
Predicted	$H_1$	TP	FP	TP+FP
	$H_0$	FN	TN	FN+TN
		TP+FN	FP+TN	

Figure 4.7: Confusion Table

The other defined metric is the Root Mean Square Error,  $\epsilon$ , which is frequently used to measure the differences between values predicted by a model or an estimator and the values actually observed from the phenomenon being modeled or estimated. Therefore,  $\epsilon$  is a measure of accuracy, [8]. Here the  $\epsilon$  is used to quantify the error between the observed state and the predicted state of the sensed channel. The  $\epsilon$  of the channel state is given by,

$$\epsilon = \sqrt{\frac{\sum_{i=1}^N (\hat{s}_i - s_i)^2}{N}} \quad (4.24)$$

where  $N$  is the number of sensing sessions. Consider that the  $\hat{s}_i$  and  $s_i$  represent the predicted state and observed state of the channel in the sensing session  $i$ , then the individual accounted differences,  $\hat{s}_i - s_i$ , are called residuals, and the  $\epsilon$  aggregates these individual residuals to quantify the error between sensed and real state of the channel during a set of successive sensing sessions.

As example of what both  $\phi$  and  $\epsilon$  measure, consider the plot in Figure 4.8, which was obtained by doing a training sequence in both  $H_0$  and  $H_1$  for the counting rule based LDDF. From the Figure 4.8 it can be seen that there is a range of the  $k$ -threshold which minimizes the  $\epsilon$  and maximizes the  $\phi$ . This range is the optimal for the considered number of local detectors and their detection performance.

#### 4.4.1 Local Detector Model

The global probabilities of detection,  $GP_d$ , and false alarm,  $GP_{fa}$ , depend on the local detectors performance, which is given by the  $p_d$  and  $p_{fa}$  pair. These can be expressed as a function of each other, where this relation depends on the detector implemented at the local detectors. Here we consider the Energy Detector [2, 9] as the detector in place in the local detectors, as described in section 3.5.1. So the  $p_d$  can be expressed as a function of  $p_{fa}$ , as follows,

$$p_d = Q \left( \frac{Q^{-1}(P_{fa}) \sqrt{2N} - NSNR}{\sqrt{2N}(1 + SNR)} \right) \quad (4.25)$$

From this equation it can be plotted the performance points of the counting rule detector in the Receiver Operating Characteristic (ROC) plot, as depicted in Figure 4.9. In the figure two cases are shown. On the first one, in Figure 4.9(a), the difference in the detector performance when using two different quantities of samples. On the second one, in Figure 4.9(b), is shown the detection performance when using a single local detector and when using a OR counting rule with 10 local detectors, i.e. when the  $k$ -threshold equals 1.

In Figure 4.10 is depicted the variation of  $\epsilon$  and  $\phi$  with  $p_{fa}$  of the local detectors and  $k$ -threshold for the counting rule, while using the model of the Energy Detector detailed above for the local detector. From the figure it can be observed that the lower is the  $p_{fa}$  then the smaller is the range as well as the smaller is the  $k$ -thresholds which minimizes the  $\epsilon$  and maximizes  $\phi$ , which is the expected result since the  $GP_d$  can be expressed as a function of  $GP_{fa}$ .

#### 4.4.2 Duty-Cycle

Until now the results shown for  $\epsilon$  and  $\phi$  where obtained while considering a mean duty cycle of 50%, i.e. referring to the confusion table in Figure 4.7 the  $TP + FN = FP + TN$ . So in Figure 4.11 is depicted the variation of  $\epsilon$  and  $\phi$  with the mean duty cycle. As expected the depicted variation shows that

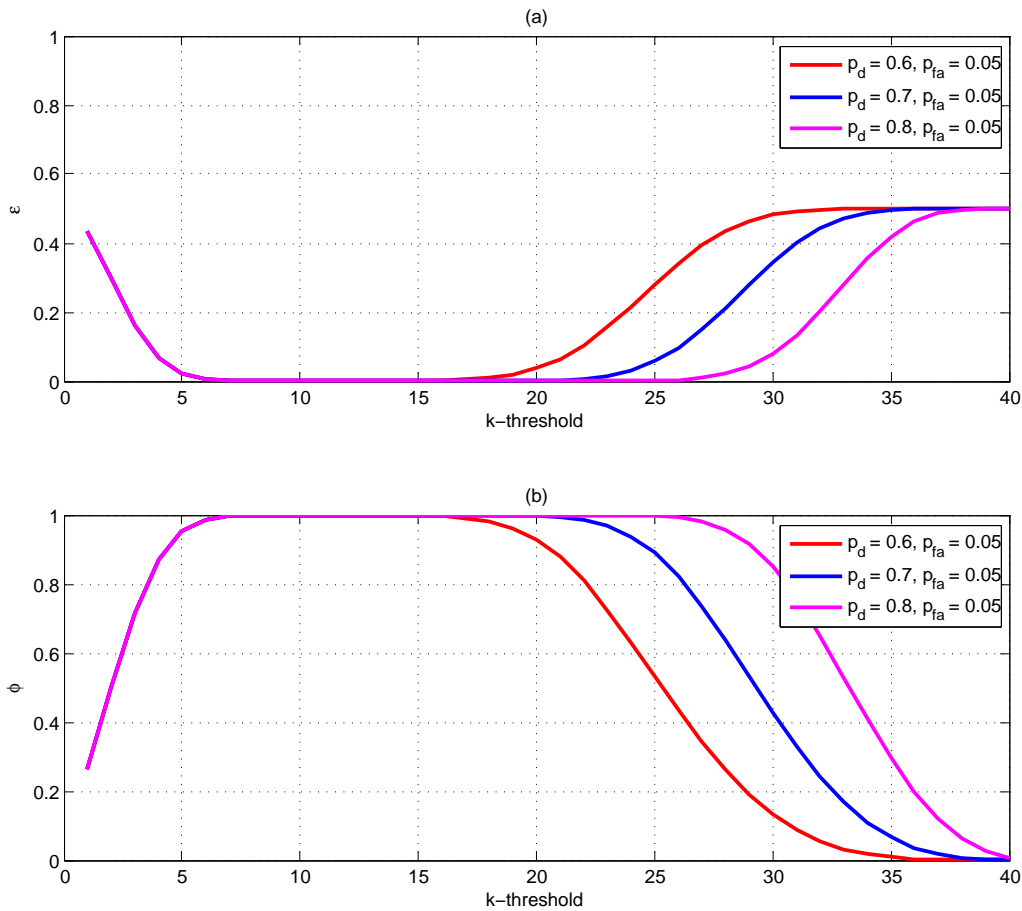

Figure 4.8: (a,b)  $\phi$  and  $\epsilon$  variation with the  $k$ -threshold for different  $p_d$  and  $p_{fa}$  pairs, with  $c = 40$

when the duty cycle is 0%, i.e.  $TP + FN = 0$ , then the detector is always under  $H_0$  and therefore the performance measured by  $\epsilon$  and  $\phi$  depends only on the  $p_{fa}$ , on the other hand when the mean duty cycle is 100% the detector is always under  $H_1$  then the performance measured by  $\epsilon$  and  $\phi$  depends only on  $p_d$ .

## 4.5 Non-Identical Local Detectors

Now after characterizing the performance of the counting rules when the local detectors are independent and identical distributed, now it is considered the case where the performance of the LDs is not identical. As mentioned before,

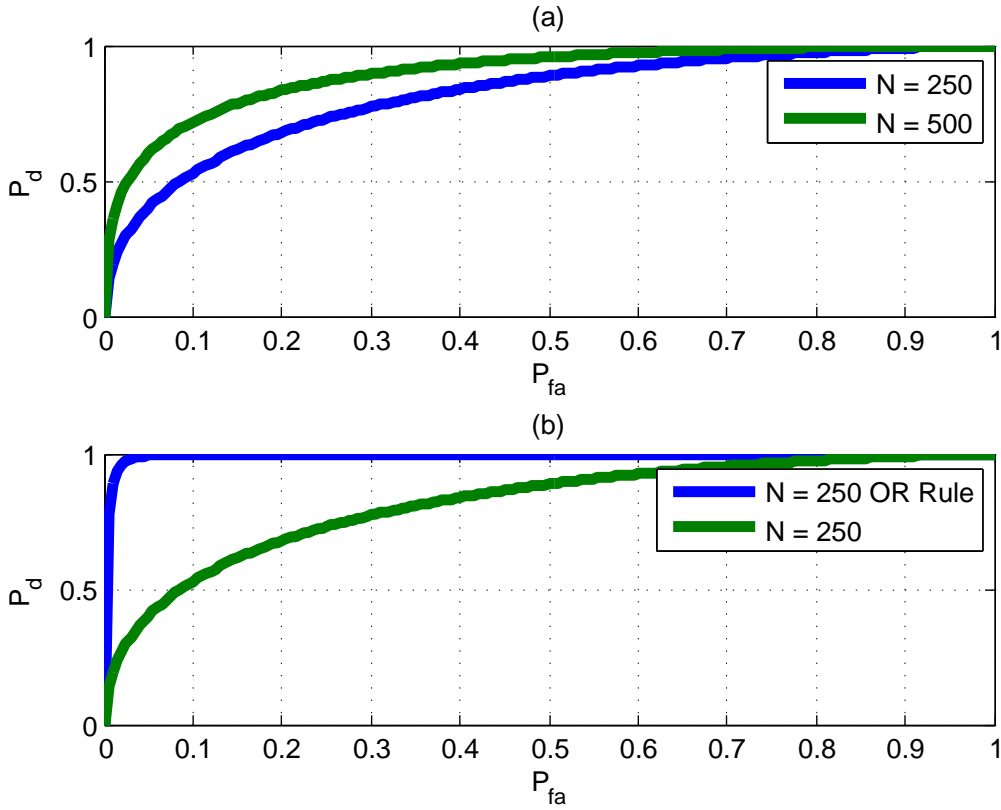

Figure 4.9: (a) Comparison of the ROC of the ED when  $N = 250$  and  $N = 500$ , (b) Comparison of the ROC of the ED and OR rule with  $N = 250$  in a single detector and  $c = 10$

when the local detectors are spread over space, is expected that their experienced  $SNR$  is different depending on their distance and position in regard to the source of the signal to be detected. So considering that the local detector is dimensioned to achieve a certain  $p_d$  to a defined  $SNR$  target, then it is expected that if the experienced  $SNR$  is lower than the target  $SNR$  then the  $p_d$  will also be lower, likewise in the reverse situation, i.e. if the experienced  $SNR$  is higher than the target  $SNR$  then the  $p_d$  will also be higher. This is illustrated in Figure 4.12, where for the Energy Detector model the  $p_d$  is plotted in function of the experienced  $SNR$ . Note that in this plot and in the remaining of this chapter it is disregarded the detection uncertainty will discussed in Chapter 2.

Consider that now there are  $c$  local detectors spread across space and that their received power will most likely follow a log-normal distribution, due to

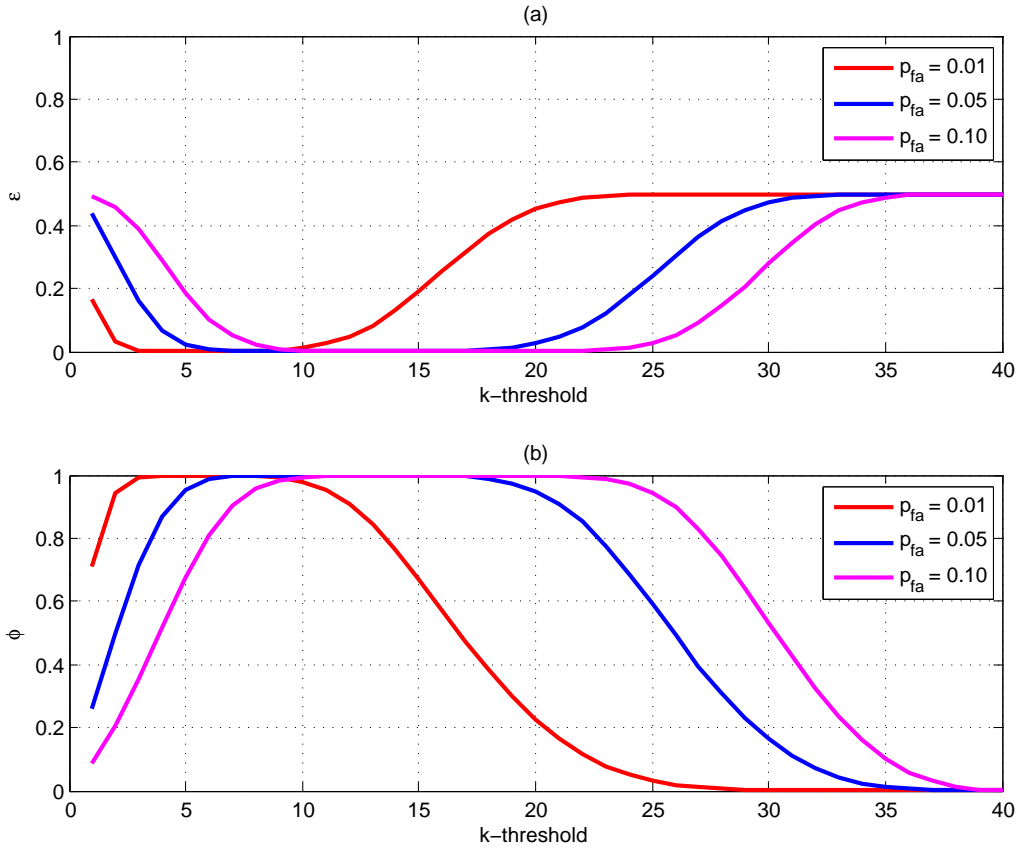

Figure 4.10: (a,b)  $\epsilon$  and  $\phi$  variation in regards to  $p_{fa}$  and  $k$ , with  $c = 40$

shadowing, then it is expected that the experienced  $SNR$  will also follow a log-normal distribution. Still in Figure 4.12 is depicted a case where the variation of the experienced  $SNR$ ,  $SNR_{exp}$ , across a number of local detectors is within  $-5$  dB and  $5$  dB. So the  $p_d$  of the LDs will vary over that range. Therefore, while considering the defined performance metrics, the performance interval is between the minimum and maximum  $p_d$ , while setting a fixed  $p_{fa}$ , while the real performance of the LDDF in these conditions is somewhere within that range, as depicted in Figure 4.13.

In the scenario depicted in both Figure 4.12 and in Figure 4.13 it is difficult to find beforehand what is the range of  $k$ -thresholds which should be used since it will depend on the individual  $p_d$  of the local detectors. Considering that the radio environment conditions can change over time, due to the local detectors mobility or the signal source mobility, it is expected that the radio environment conditions experienced by the local detectors will also change over time.

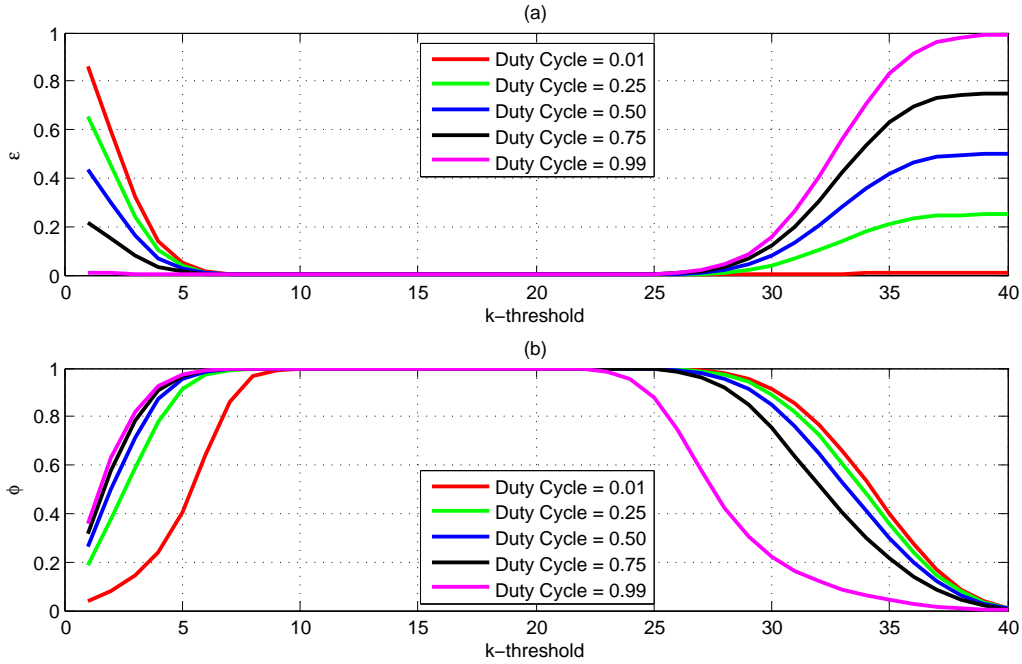

Figure 4.11: (a,b)  $\epsilon$  and  $\phi$  variation in regards to Duty Cycle and  $k$ , with  $c = 40$ ,  $p_d = 0.8$  and  $p_{fa} = 0.05$

Now consider the plots depicted in Figure 4.14, where three different  $\sigma$  were considered to generate the  $p_d$  of each of the local detectors, i.e. to represent three different shadowing conditions. From the plot it can be seen that, depending on these shadowing conditions, the ranges of  $k$ -thresholds which maximizes  $\phi$  and minimizes  $\epsilon$  are different.

Now consider the plot depicted in Figure 4.15, where it is shown the variation of both  $\phi$  and  $\epsilon$  in regards to  $\sigma$  ranging from 0 dB to 20 dB in 1 dB steps. From the Figure 4.15 plot it can be seen that the higher is the considered  $\sigma$  then the smaller is the range of  $k$ -thresholds values which maximize  $\phi$  and minimize  $\epsilon$ .

In Figure 4.16 is shown a plot with the variation of both  $\phi$  and  $\epsilon$  in regards to  $p_{fa}$ , where it can be seen that the lower is the  $p_{fa}$  then the lower is the  $k$ -threshold range which maximizes  $\phi$  and minimizes  $\epsilon$ .

While in the case where the local detectors are i.i.d. it is possible to derive analytically the  $k$ -threshold to be used, in the now considered case the same is not possible. Especially if it is considered that the data fusion center does not have information about the individual  $p_d$  and  $p_{fa}$  of the local detectors. So the data fusion center needs to be able to estimate what is the proper

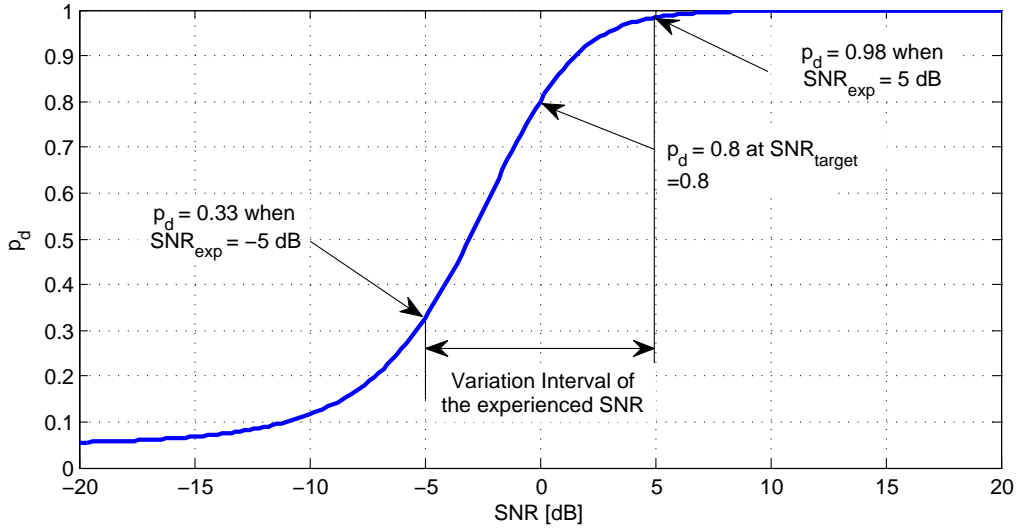

Figure 4.12:  $p_d$  of the Energy Detector in function of the experienced  $SNR$ , with  $p_{fa} = 0.05$ ,  $SNR_{Target} = 0dB$

$k$ -threshold value range to be used, but for this estimation to occur it needs feedback information regarding the impact of using a given  $k$ -threshold value range. In the next section an algorithm framework is proposed for an adaptive mechanism which allows the data fusion center to adapt  $k$ -threshold range, based on feedback provided by the network while using the results from the data fusion center decisions.

## 4.6 Adaptive Counting Rule

Here is assumed that the data fusion center has available information about the local decisions of the local detectors and that those decisions are each encoded in one bit, i.e. the local decisions are of the hard decision type. It is also assumed that the data fusion center does not have access to measurements on the radio conditions that the local detectors are experiencing, and consequently is not able to estimate the local detectors performance. Therefore is not possible for the data fusion center to compute the optimal  $k$ -threshold and so there is the need for a mechanism that is able to tune the  $k$ -threshold based on the received local decisions and the performed global decisions over the time.

Here is proposed a mechanism which adapts the  $k$ -threshold continuously based on the feedback from the previous global decisions. This approach allows to adapt to the radio environment conditions at the local detectors without



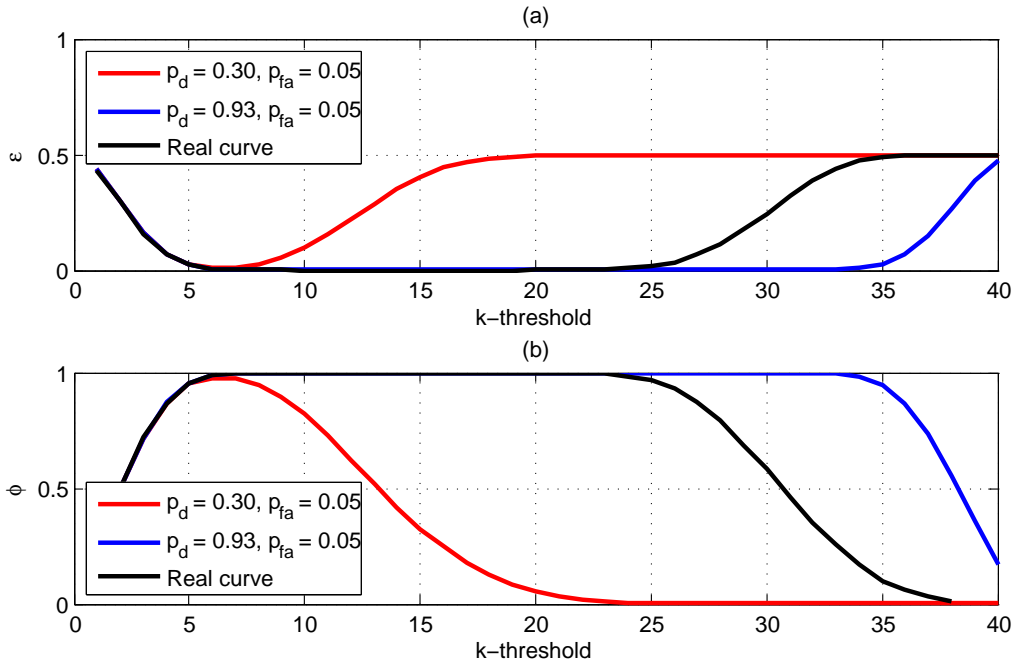

Figure 4.13: (a,b)  $\epsilon$  and  $\phi$  variation in regards to minimum and maximum  $p_d$  and the heterogeneous  $p_d$

having implicit information about them, by instead using the information from that feedback.

The algorithm framework which implements the Adaptable Counting Rule (ACR) mechanism is listed in Algorithm 1. This algorithm framework adapts the decision  $k$ -threshold, so that for a detection to occur there has to be at least  $k$  positive detections out of the  $c$  local detectors.

Where the meaning of the metrics shown in the Algorithm 1 is the following:

- *MDC* - The misdetection counter counts every time the fusion center decides that the channel is free, and the network tries to use the channel but the channel is occupied;
- *ODC* - The occupied detection counter counts every time the fusion center decides the channel is occupied;
- *OW* - The observation window is the time interval of the observations used to make the decisions, i.e. it serves as the memory of what occurred in the previous sensing sessions;

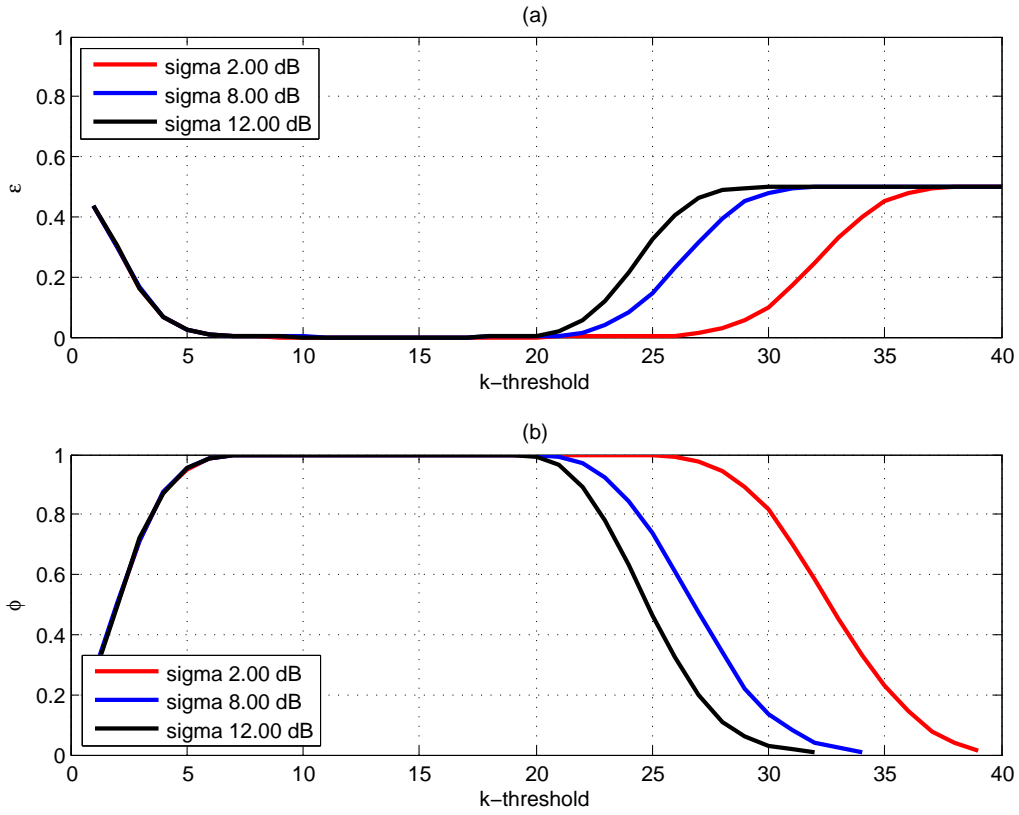

Figure 4.14: (a,b)  $\epsilon$  and  $\phi$  variation with heterogeneous  $p_d$  depending on  $\sigma$

- $MD_{Thrs}$  - The misdetection threshold is the amount of misdetections permitted within the observation window. When this value is overcome, it triggers the decrease of the  $k$ -threshold;
- $OC_{Thrs}$  - The occupied detection threshold is the amount of occupied detections occurring during the  $OW$ , which, if exceeded, triggers the increase of the  $k$ -threshold;
- $CS$  - The channel state is the actual channel state, which is found when one of the local detectors tries to access the channel;
- $k$  - Is the  $k$ -threshold;
- $H_0$  - Is the state of the channel when it is vacant;
- $H_1$  - Is the state of the channel when it is occupied;
- $k_{Step}$  - Is the step which the  $k$  is increased or decreased;
- $k_{initial}$  - Is the initial  $k$ -threshold value;

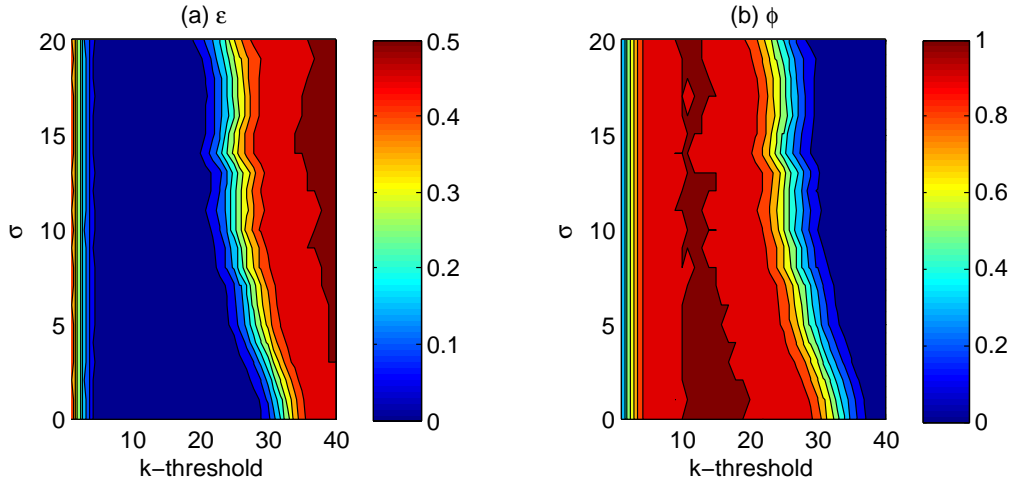

Figure 4.15: (a,b)  $\epsilon$  and  $\phi$  variation with heterogeneous  $p_d$  depending on  $\sigma \in [0, 20]$  dB

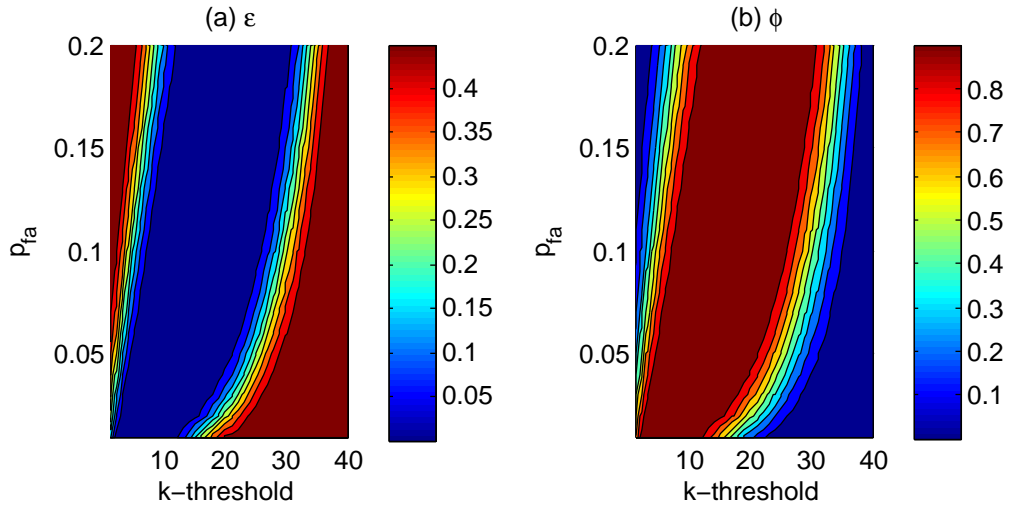

Figure 4.16: (a,b)  $\epsilon$  and  $\phi$  variation with  $p_{fa} \in [0.01, 0.2]$

- $u_{H_1}$  - Is the number of local detectors which their local decision is  $H_1$ .

The rationale behind the ACR algorithm, is that in the case where the sensed channel is deemed vacant, then at least one pair of LDs in the network will try to communicate through the sensed channel and the result of that action can then be used as feedback to tune the  $k$ -threshold. In the case where one of the local detectors tries to transmit and the channel is not vacant, i.e. a collision occurs, then it means that there was a misdetection and therefore

**Algorithm 1** Adaptive counting rule mechanism

---

```

if Initial Sensing Iteration then
     $k = k_{initial}$ 
end if
if  $u_{H_1} \geq k$  then
     $ODC = ODC :: 1$ 
     $MDC = MDC :: 0$ 
else
     $ODC = ODC :: 0$ 
    if  $CS \neq H_0$  then
         $MDC = MDC :: 1$ 
    end if
end if
if  $MDC > MD_{Thrs}$  then
    Increase  $k$  by  $k_{step}$ 
end if
if  $ODC > OC_{Thrs}$  then
    Decrease  $k$  by  $k_{step}$ 
end if
if  $k$  was updated then
    Set  $MDC = []$  and  $ODC = []$ 
else
    Discard  $MDC$  and  $ODC$  elements outside the  $OW$ 
end if

```

---

the  $k$ -threshold should decrease so the  $GP_d$  increases. At the same time there should be an inverse mechanism which increases  $k$ -threshold, so to ensure that a upper bound of the  $GP_{fa}$  is respected. The system feedback, used to tune the  $k$ -threshold, can be obtained by the statistics of the successful transmissions, failed transmissions, and on the case of a Carrier Sense Multiple Access with Collision Avoidance based system on the number of times that the Collision Avoidance mechanism was put in place.

The performance of the proposed algorithm depends on the values selected for the thresholds  $MD_{Thrs}$  and  $OC_{Thrs}$  and on the selected  $OW$ . It was observed that after several trials, the value of the initial  $k$ -threshold,  $k_{initial}$ , only affects the initial iterations and after that the  $k$ -threshold quickly falls within the optimal  $k$ -threshold range. It was also found that the duty cycle of the interfering signal also affects the performance of the proposed algorithm, where it was observed that an high duty cycle, above 0.6, makes the  $k$ -threshold tend towards upper bound of the accepted  $k$ -threshold range, while a low duty cycle,

below 0.4, makes the  $k$ -threshold tend towards lower bound of the accepted  $k$ -threshold range.

As an example consider the plot in Figure 4.17, where it is shown the result of the algorithm adapting the  $k$ -threshold over time. In the same plot is also shown the interval where the  $k$ -threshold should fall into, which was obtained by considering  $\phi \geq 0.9$ , following the same approach as discussed as in section 4.5 for obtaining  $\phi$ . It was considered a duty cycle of 0.6 and  $MD_{Thrs} = 1$  while  $OC_{Thrs} = 0.8OW$ . In the plot it can be seen that the  $k$ -threshold keeps within the accepted  $k$ -threshold range.

To illustrate how the performance of the algorithm is dependent of  $MD_{Thrs}$  and  $OC_{Thrs}$  consider the following plots depicted in Figure 4.18, which depict the variation of  $\phi$  in regards to  $MD_{Thrs}$  and  $OC_{Thrs}$ , while considering four different Duty Cycles values for the signal source.

From the plots in Figure 4.18, it can be seen that when using the lowest possible  $MD_{Thrs}$ , it is always possible to obtain an higher  $\phi$  in any of the considered duty cycle cases. While when considering the behaviour of the proposed algorithm in regards to the  $OC_{Thrs}$ , it can be seen that the higher is the duty cycle then the higher should be the  $OC_{Thrs}$ . Although, as observed for lower duty cycles the  $OC_{Thrs}$  which maximizes the  $\phi$  is closely related to the duty cycle, which suggests that the algorithm should take the duty cycle into account.

Now to illustrate what should be the optimum  $OC_{Thrs}$  which maximizes the  $\phi$  obtained by the ACR algorithm, consider the plot depicted in Figure 4.19, where  $MD_{Thrs} = 1$ .

From the plot in Figure 4.19(a), it is observed that there is a linear relation between the duty cycle and the  $OC_{Thrs}$  which maximizes the  $\phi$ , as shown in Figure 4.19(b). Therefore, the ACR algorithm needs to be able to adjust the  $OC_{Thrs}$  according to the experienced duty cycle. The Algorithm 1 is modified accordingly and the updated version is listed in Algorithm 2.

In Algorithm 2, a new metric  $OCS$  which stores the observed channel state within the  $OW$  was added, which is then used as an estimator for the  $OC_{Thrs}$  through the estimator function  $f(OCS)$ , defined as,

$$f(OCS) = \frac{\sum OCS}{OW} OW + C_f OW \quad (4.26)$$

where  $C_f$  is a correction factor, which for the observed cases can be set to  $C_f = 0$ .

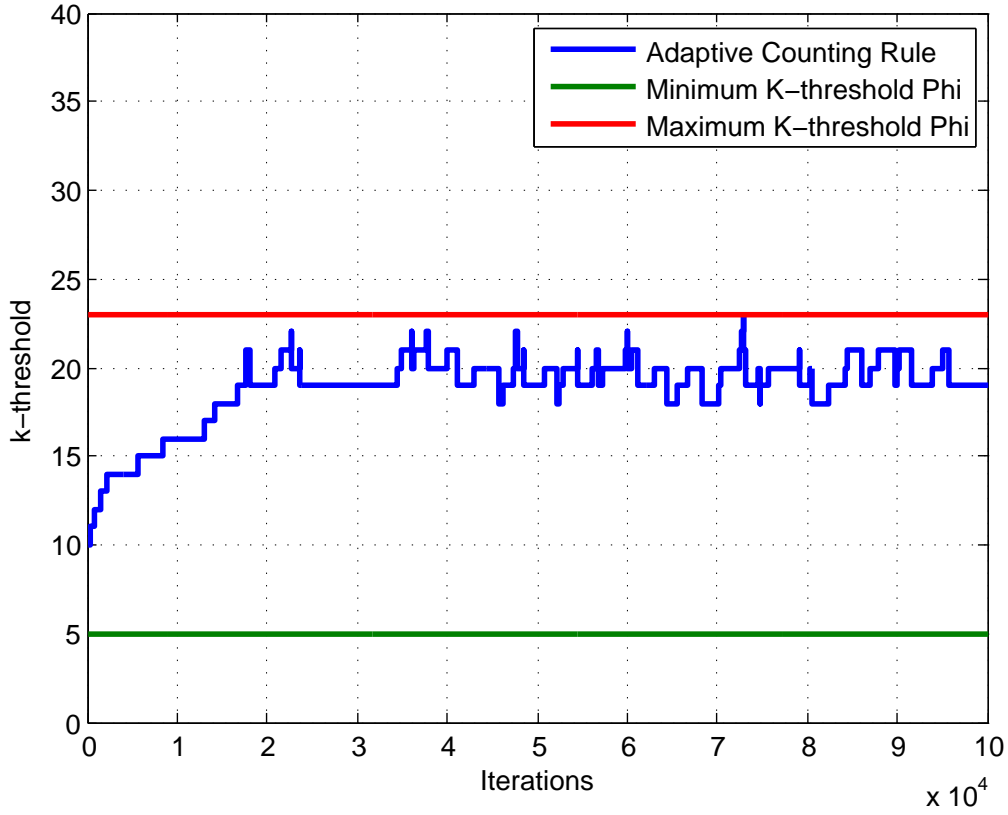

Figure 4.17: Adaptive Counting Rule versus time.

In Figure 4.20 is depicted the variation of the  $k$ -threshold over time for both the Modified Adaptable Counting Rule (MACR) and ACR. It can be observed that the MACR adapts the  $k$ -threshold while the ACR maintains it constant, which occurs due to the initial chosen  $OC_{Thrs}$ .

The MACR algorithm performance versus the duty cycle is depicted in Figure 4.21(a). As seen in the plot, the  $\phi$  of the MACR algorithm is higher when the signal duty cycle is between 0.1 and 0.9. It can also be observed that the  $OC_{Thrs}$  does not vary linearly with the signal duty cycle. This occurs because the  $OW$  is finite and therefore there is an estimation error associated with the estimated duty cycle. If the size of the  $OW$  is increased then it is expected that the duty cycle estimation error will decrease, leading to a smaller variation of the  $OC_{Thrs}$ . In Figure 4.21(b) is shown the  $\phi$  of the ACR algorithm in regards to the duty cycle, where it can be seen that if a proper initial  $OC_{Thrs}$  is not chosen then the algorithm performs bad, as depicted in the plot.

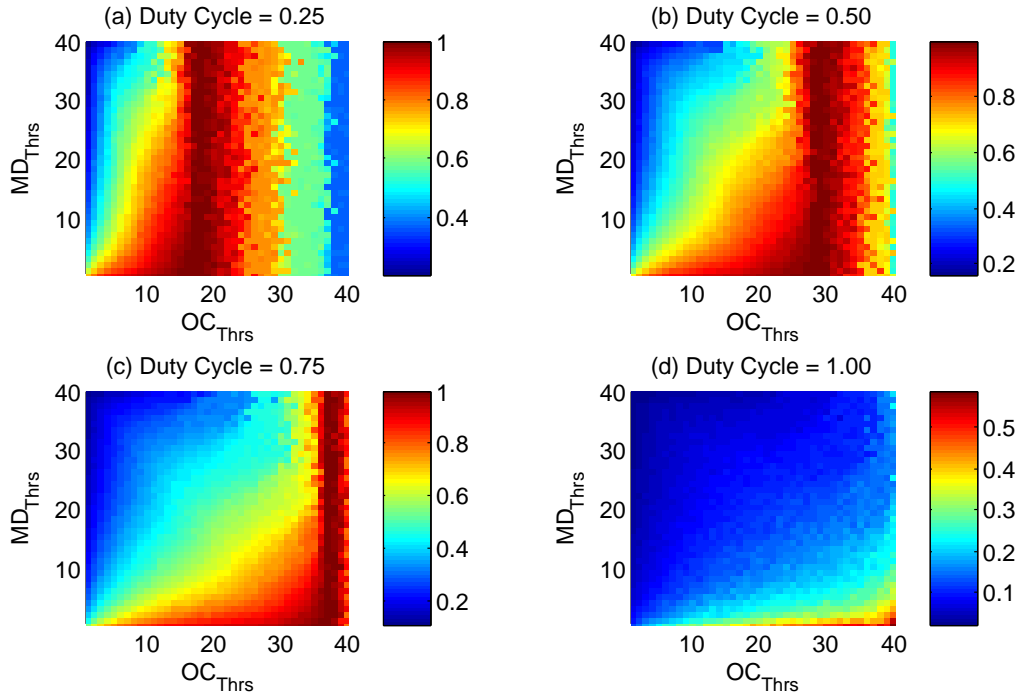

Figure 4.18: Adaptive Counting Rule performance in regards to  $\phi$  versus  $MD_{Thrs}$  and  $OC_{Thrs}$  for different duty cycles, with  $\sigma = 8dB$  and  $c = 40$

The proposed ACR and MACR algorithms are both able to adapt the decision threshold,  $k$ , according to the experienced channel conditions and to the signal duty cycle changes. The rate of adaptation depends on the length of the observation window,  $OW$ . While a high  $OW$  leads to a slower adapting algorithm a lower  $OW$  leads to a faster adapting algorithm, although less stable. It was shown that the MACR performance is superior to the ACR, since the MACR is able to adapt to the signal duty cycle, while the ACR parameters need to be optimized for each duty cycle, to achieve the same performance as the MACR.

In the next section the concept of capacity in a data fusion context is introduced, which is then used to analyze the performance of the proposed MACR.

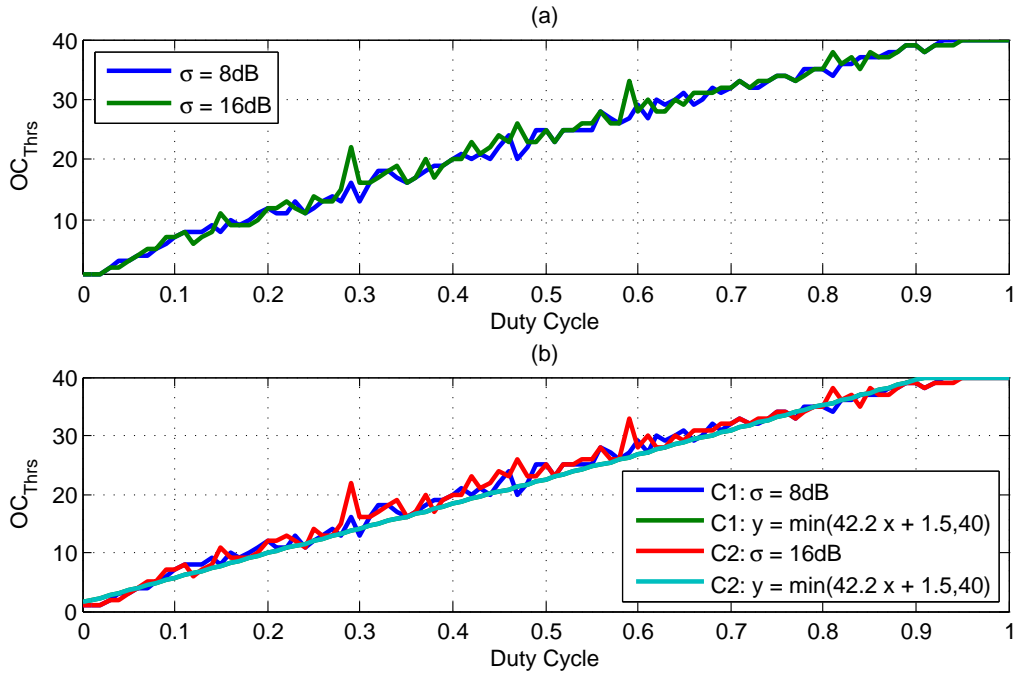

Figure 4.19: (a) Optimum  $OC_{Thrs}$  which maximizes the  $\phi$  obtained by ACR versus the duty cycle, for different  $\sigma$  and  $c = 40$  (b) Optimum  $OC_{Thrs}$  fitted curve

## 4.7 Capacity Limits introduced by Data Fusion

When performing the LDDF the exposed node problem is aggravated. This occurs since when combining sensing results from positions far apart, one loses information about possible available spectrum opportunities, i.e. it loses the information about the spatial diversity. This phenomenon is illustrated in Figure 4.22, where the coloured regions represent where the spectrum is available and non-coloured where the spectrum is occupied. After the Data Fusion (DF) occurs the information about the regions where the spectrum was available disappears, causing the network to lose that information.

In this section it is defined what is the capacity perceived by the cooperative spectrum sensing mechanism, focusing on the loss of perceived capacity introduced by the use of data fusion. This analysis is done along the data fusion chain, comparing several scenarios encompassing different degree of environmental correlation between the local detectors, number of local detectors and sensed channel occupation statistics. To answer this question, first is



**Algorithm 2** Modified Adaptive counting rule mechanism

---

```

if Initial Sensing Iteration then
     $k = k_{initial}$ 
end if
if  $u_{H_1} \geq k$  then
     $ODC = ODC :: 1$ 
     $MDC = MDC :: 0$ 
     $OCS = OCS :: 1$ 
else
     $ODC = ODC :: 0$ 
    if  $CS \neq H_0$  then
         $MDC = MDC :: 1$ 
         $OCS = OCS :: 1$ 
    else
         $OCS = OCS :: 0$ 
    end if
end if
if  $MDC > MD_{Thrs}$  then
    Increase  $k$  by  $k_{step}$ 
end if
if  $ODC > OC_{Thrs}$  then
    Decrease  $k$  by  $k_{step}$ 
end if
if  $k$  was updated then
    Set  $MDC = []$  and  $ODC = []$ 
else
    Discard  $OCS, MDC$  and  $ODC$  elements outside the  $OW$ 
     $OC_{Thrs} = f(OCS)$ 
end if

```

---

necessary to introduce new metrics which will allow to measure the system perceived capacity.

### 4.7.1 System Capacity Metrics

In this subsection is defined what is meant by the system's perceived capacity, from a cooperative spectrum sensing mechanism, along the data fusion chain. In Figure 4.23 the steps that constitute the data fusion chain are depicted, where  $U_{e,n}$ ,  $U_{s,n}$  and  $U_{df}$  quantify the perceived state of the sensed channel at each step of the data fusion chain. The  $U_{e,n}$  quantifies the experienced state

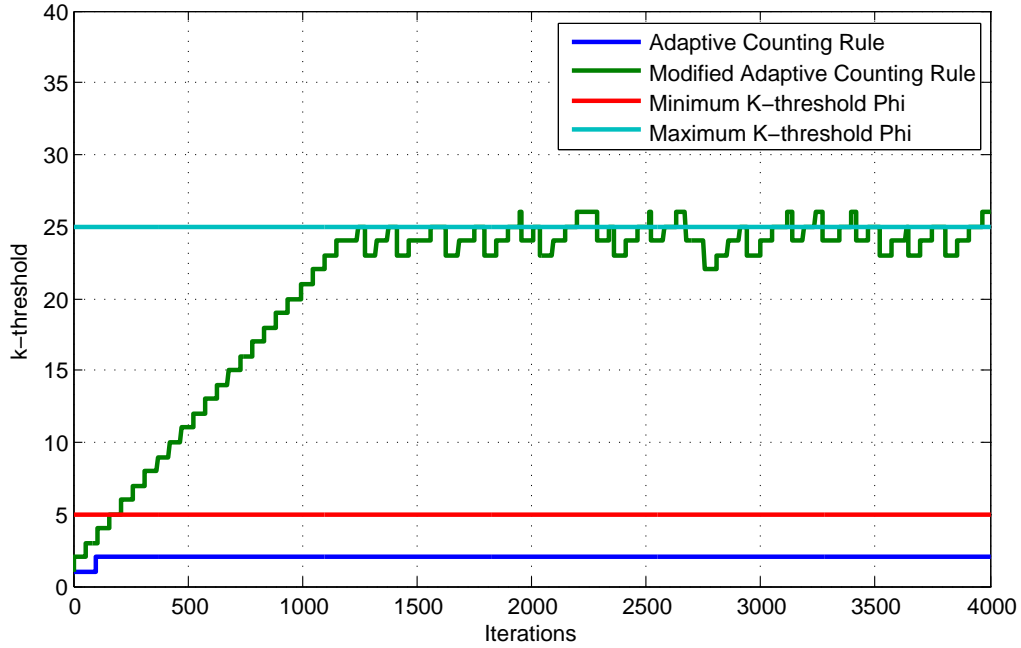

Figure 4.20:  $k$ -threshold variation of MACR and ACR vs time, with  $c = 40$ ,  $OW = 100$ ,  $MD_{Thrs} = 1$ , initial  $OC_{Thrs} = OW$  and duty cycle 0.5

of the channel targeted for sensing by the local detector. The  $U_{s,n}$  quantifies the perceived state of the channel after sensing. Finally,  $U_{df}$  quantifies the perceived channel state after the data fusion. The values that each of these states can take are,

$$U_{e,n}, U_{s,n}, U_{df} = \begin{cases} 1 & \text{if } H_0 \\ 0 & \text{if } H_1 \end{cases} \quad (4.27)$$

To illustrate the meaning of system perceived capacity, first consider that in a CSS session there are several participating local detectors, and that each of these experiences different signal strength, due to path loss, fast fading, shadowing, etc. Now if one considers that at the location of each of these sensing nodes, the channel is deemed free for use if the signal strength is below a given Signal to Noise Ratio (SNR) threshold, then it is expected that due to the mentioned varying channel conditions, some of the local detectors will experience the same channel as free while other will experience it as occupied, i.e. when the signal is above the SNR threshold. Note that what is meant by experienced channel state refers to the actual state of the sensed channel at a particular geographical location, given by  $U_{e,n}$ , i.e. before the sensing takes place. Following the data fusion chain in Figure 4.23, in Figure 4.24 is depicted

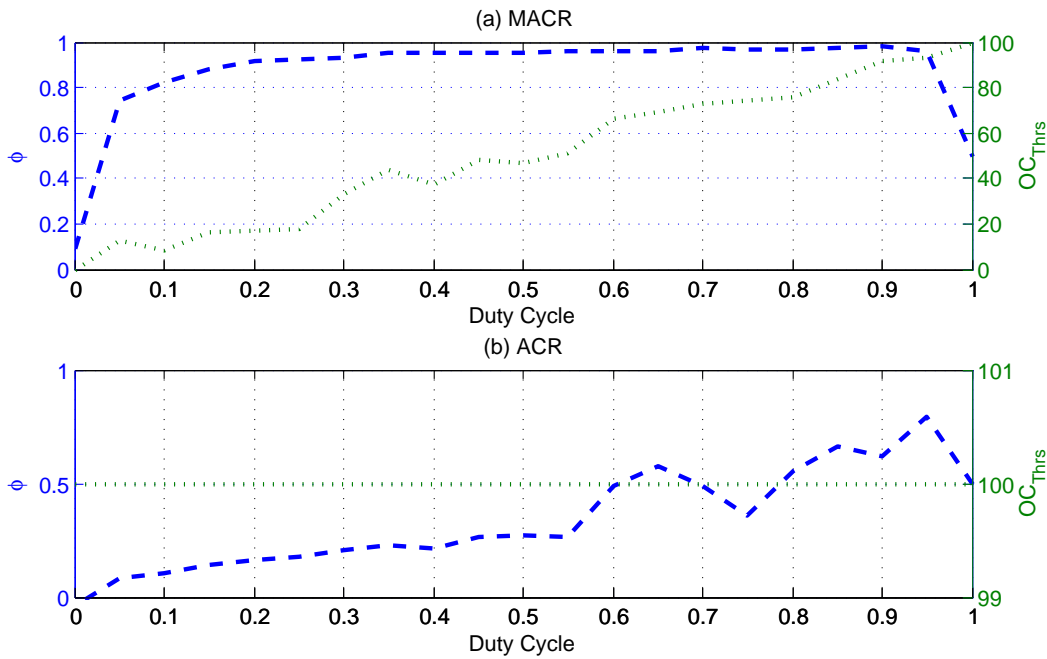

Figure 4.21:  $\phi$  vs duty cycle, for MACR and ACR, with  $c = 40$ ,  $OW = 100$ ,  $MD_{Thrs} = 1$  and initial  $OC_{Thrs} = OW$

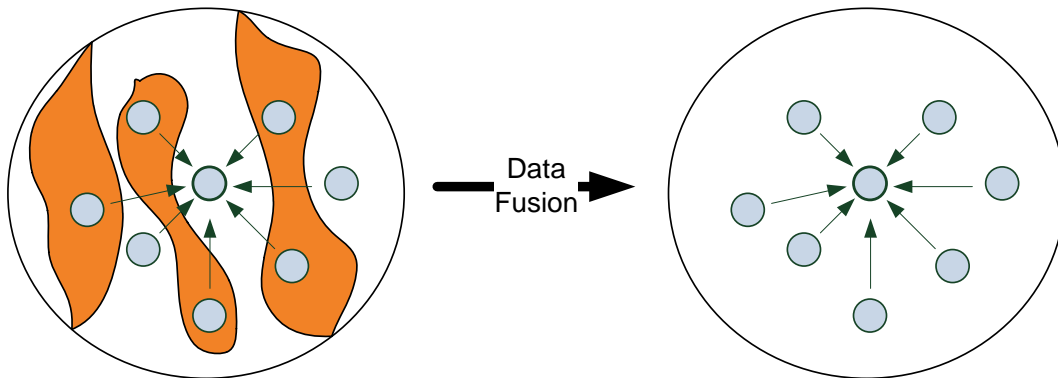

Figure 4.22: The drawback of using data fusion, the loss of spatial diversity

the status of the perceived channel state at each step of the data fusion chain, given by  $U_e$ ,  $U_s$  and  $U_{df}$ . Each of the figure's blocks represents a sensing node and its color the perceived channel state.

When comparing the experienced spectrum state,  $U_e$ , and sensed spectrum state,  $U_s$ , it can be seen that some of the local detectors fail to detect that the channel is occupied, i.e. a missed detection occurs, while the other local detectors judge the channel as occupied when it is not, i.e. a false detection or false

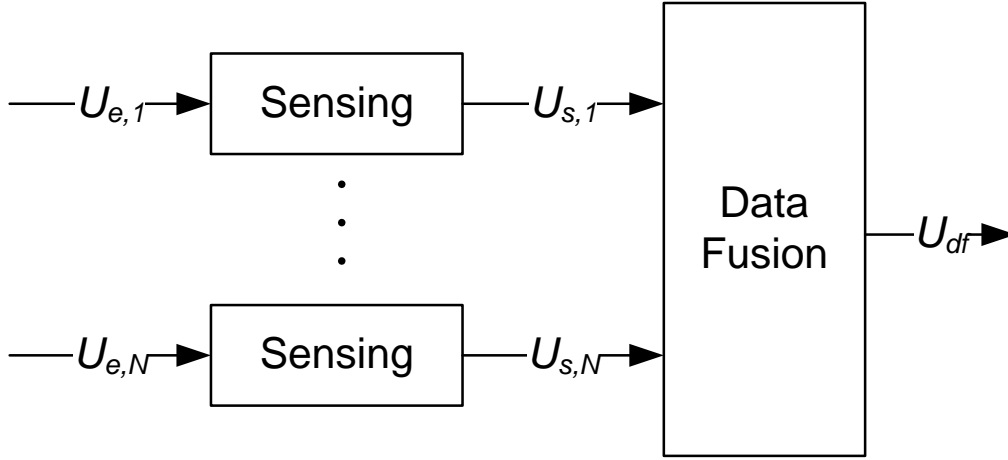

Figure 4.23: Capacity along the paralel data fusion chain

alarm occurs. Both events have impact on the perceived system capacity, the missed detections because they cause the local detector to perceive a channel as free when it is occupied, and the false alarm because the node perceives the channel as occupied when it is free. So in the former, one assumes to have more resources than the ones available, while in the latter one misses the available resources.

After the data fusion takes place,  $U_{df}$ , all local detectors are assumed to perceive the channel state that resulted from the data fusion. From the example in Figure 4.24, after the data fusion all local detectors are assumed to perceive the channel as occupied, although some of the nodes actually perceive the channel as free, causing a decrease of the system perceived capacity.

To measure the system perceived capacity at the different stages of the data fusion chain, several metrics are defined. While what is meant by capacity in the cooperative spectrum sensing context is the number of local detectors which are experiencing or perceiving the channel state as free.

The potential capacity of the set of considered local detectors, given by  $C_r$ , is defined as,

$$C_r = \frac{\sum_{i=1}^N U_{e,i}}{N} \quad (4.28)$$

where  $U_{e,i}$  is the experienced channel state of the  $i^{th}$  local detector and  $N$  the number of local detectors. This metric allows to measure the fraction of local detectors that are experiencing a free channel, i.e. before the sensing takes place.

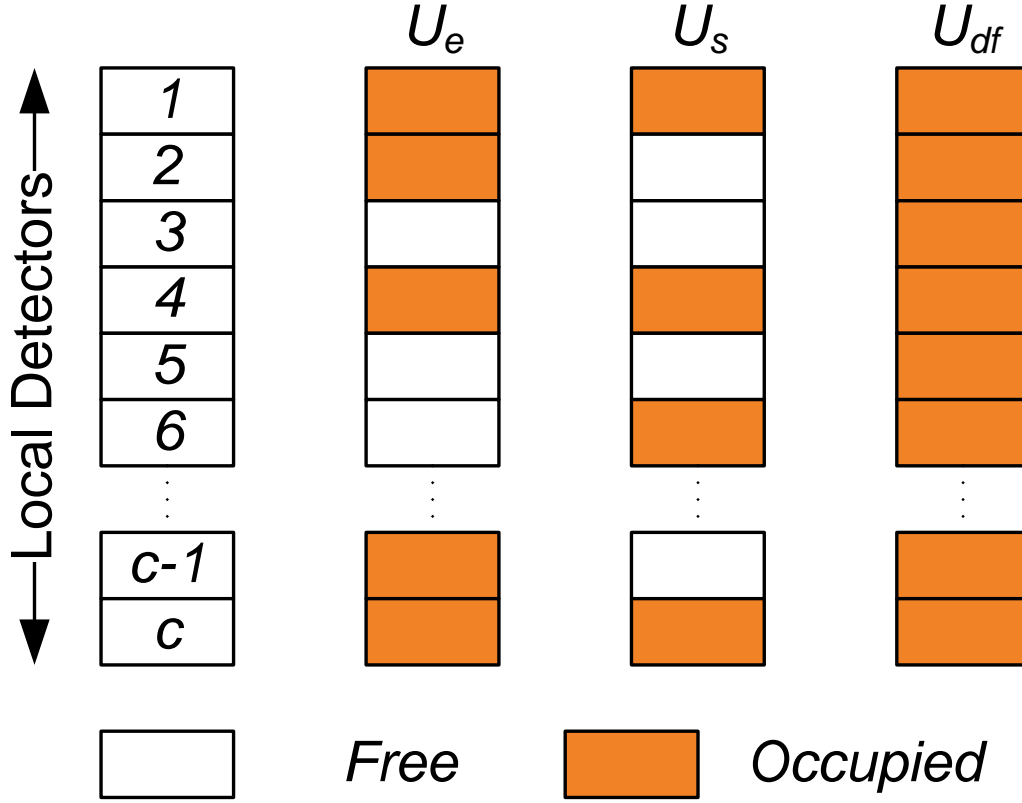

Figure 4.24: Spectrum sensing capacity illustration

The post-sensing capacity of the considered local detectors set, given by  $C_s$ , is defined as,

$$C_s = \frac{\sum_{i=1}^N U_{s,i} U_{e,i}}{N} \quad (4.29)$$

where  $U_{s,i}$  is the sensed channel state of the  $i^{th}$  local detector. This metric allows measuring the fraction of local detectors that perceive the sensed channel as free when the channel is in fact free. Therefore when a local detector perceives the channel as occupied when it is actually free, i.e. a false alarm as occurred, then the  $C_s$  does not consider it. So the occurrence of false alarms is the phenomenon that causes the  $C_s$  to be lower than the  $C_r$ .

The post-data fusion capacity of the set of the considered local detectors, given by  $C_{df}$ , is defined as,

$$C_{df} = U_{df} \frac{\sum_{i=1}^N U_{e,i}}{N} \quad (4.30)$$

where  $U_{df}$  is the decided spectrum state after the data fusion. This metric measures the fraction of local detectors of the set that are indeed experiencing a free channel when the perceived state resulting from the data fusion is as free channel. Here the occurrence of false alarms, i.e. perceiving the channel as occupied and it is free, causes the  $C_{df}$  to be lower than the  $C_r$ .

The  $C_r$ ,  $C_s$  and  $C_{df}$  are the system's perceived capacity at three different points of the data fusion chain, and the difference among them accounts for the probability of false alarm, i.e. of perceiving the spectrum as occupied when it is in fact free. But these metrics do not account for the effect of perceiving erroneously the channel state as free, i.e. they do not account for the occurrence of misdetections.

The potential false capacity of the set of considered local detectors, given by  $FC_r$ , is defined as,

$$FC_r = 1 - C_r \quad (4.31)$$

where  $C_r$  is the potential capacity of the set of considered local detectors. This metric allows to measure the fraction of local detectors that can potentially decide the channel to be free when it is not, i.e. before the sensing takes place.

To measure the fraction of local detectors which perceive erroneously the channel as free post sensing, the post-sensing false capacity, given by  $FC_s$ , is defined as,

$$FC_s = \frac{\sum_{i=1}^N U_{s,i} (1 - U_{e,i})}{N} \quad (4.32)$$

where  $U_{s,i}$  is the sensed channel state of the  $i^{th}$  local detector. This metric allows measuring the fraction of nodes that perceive the sensed channel as free when the channel is in fact occupied, this achieved by using the term  $(1 - U_{e,i})$ .

To measure the fraction of local detectors which perceive erroneously the channel as free post data fusion, the post-data fusion false capacity is defined, given by  $FC_{df}$ , as,

$$FC_{df} = U_{df} \frac{\sum_{i=1}^N (1 - U_{e,i})}{N} \quad (4.33)$$

where  $U_{df}$  is the decided spectrum state after the data fusion. This metric measures the fraction of local detectors of the set that are indeed experiencing a occupied channel when the perceived state resulting from the data fusion is as free channel.

To visualize better the obtained results, the  $C_s$  and  $C_{df}$  can be normalized in regards to  $C_r$ , and are defined as,

$$\bar{C}_s = \frac{C_s}{C_r} \quad (4.34)$$

$$\bar{C}_{df} = \frac{C_{df}}{C_r} \quad (4.35)$$

while the  $FC_s$  and  $FC_{df}$  can be normalized in regard to  $(1 - C_r)$ , and are defined as,

$$\overline{FC}_s = \frac{FC_s}{1 - C_r} \quad (4.36)$$

$$\overline{FC}_{df} = \frac{FC_{df}}{1 - C_r} \quad (4.37)$$

Through these five metrics it is possible to characterize completely the perceived capacity at each point of the data fusion chain, and therefore to understand and quantify the capacity limits achieved by using different data fusion schemes as well on the case where the data fusion is not performed. In Figure 4.25 is depicted an example where the defined metrics are applied and where it can be seen that although the data fusion scheme minimizes the False Capacity, i.e. it maximizes the  $GP_d$ , at the same time it also minimizes the Capacity, i.e. maximizes the  $GP_{fa}$ . In the next sub-section is shown and analyzed how the Capacity and False Capacity vary in different situations.

## 4.7.2 Effect of Environment Correlation on System Capacity

Here is studied how varying correlation between the local detectors affects the capacity perceived by the cooperative spectrum sensing scheme. The correlation considered in this study is the average correlation index across all the local detectors. Where the pair wise correlation is obtained from the Pearson's product-moment coefficient,  $\rho$ , defined as

$$\rho_{ij} = \frac{E[u_i u_j | H_k] - E[u_i | H_k] E[u_j | H_k]}{\sqrt{E[(u_i - E[u_i])^2 | H_k] E[(u_j - E[u_j])^2 | H_k]}}, \forall_{i,j} i \neq j, k = 0, 1 \quad (4.38)$$

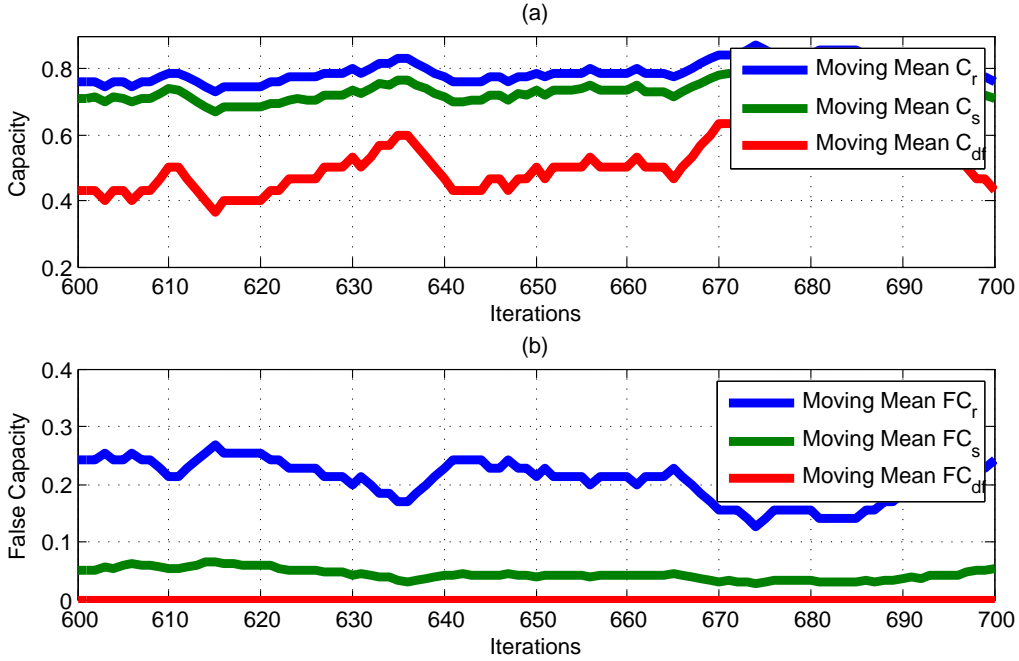

Figure 4.25: Capacity and False Capacity metrics use illustration

where  $u_i$  and  $u_j$  are the sequence of decisions at the  $i^{th}$  and  $j^{th}$  local detectors. The average correlation index,  $\rho$ , is defined as,

$$\rho = \frac{\sum_{i=1}^N \sum_{j=1}^N \rho_{ij}}{2N}, \forall_{i,j} i \neq j \quad (4.39)$$

The study was performed with the aid of simulation using a scenario where 4 signal sources were present and the local detectors were deployed around them following a uniform distribution. The  $\rho$  variation was obtained through artificial means by adjusting the noise level at each of the local detectors while maintaining the transmission power constant at the signal sources. Through this process was then possible to obtain a correspondence between the noise level and the average correlation, as depicted in the plot in Figure 4.26. Although not possible to replicate the same scenario experimentally, it serves as an approximation which allows to control the average experienced correlation by the local detectors.

The main simulation setup parameters are listed in Table 4.1. Where the  $SNR_{target}$  is the SNR to which the Energy Detector is dimensioned to detect with the  $p_{d,target}$  and  $p_{fa,target}$ , while the  $SNR_{Threshold}$  is the SNR level below which the local detector is deemed to be experiencing a vacant channel.

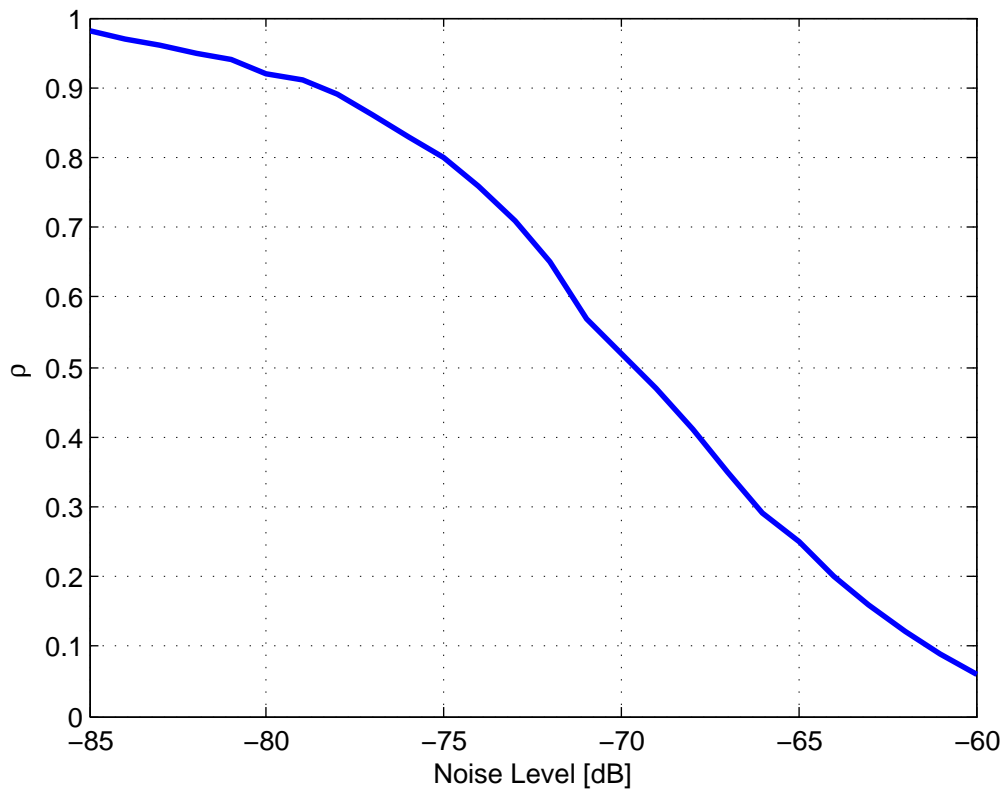

Figure 4.26:  $\rho$  vs Noise Level at the local detectors

Parameter	Value
Primary Signal Duty Cycle	0.5
Number of Local Detectors	20
Detector Model	Energy Detector
$p_{d,target}$	0.80
$p_{fa,target}$	0.05
$SNR_{target}$	0 dB
$SNR_{Threshold}$	-7.5 dB
Correlation Index Variation	0 to 1

Table 4.1: Relevant simulation parameters

In Figure 4.27 is plotted the behaviour of the Capacity and False Capacity of a data fusion based CSS mechanism in regards to the average experienced correlation. The plots consider the ACR presented previously as well as the OR counting rule. i.e. (1 - out - of - c).

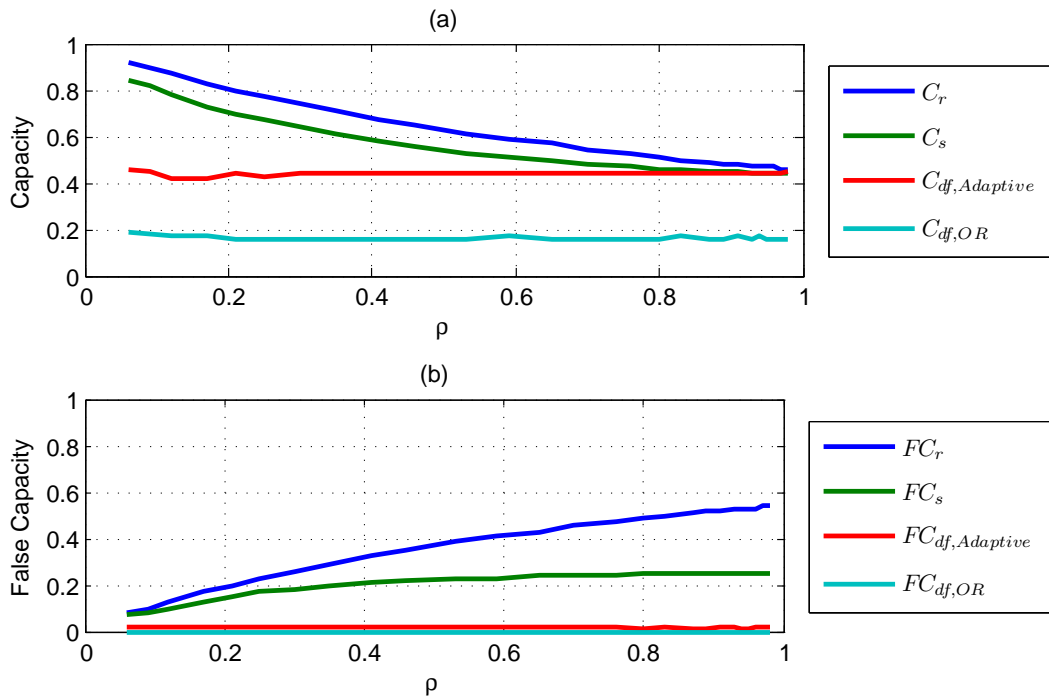

Figure 4.27: (a) Capacity and (b) False Capacity versus average local detectors experienced correlation

From Figure 4.27(a), it is seen that the  $C_r$  decreases with the increase of the  $\rho$ . This occurs because the higher is the correlation, the lower is the spatial diversity leading to lower potential capacity. The  $C_s$  follows the same behavior, and the observed gap between the  $C_r$  and  $C_s$  is due to the  $p_{fa}$  of the local detectors. For both data fusion schemes the  $C_{df}$  maintains the same perceived capacity along the  $\rho$  variation. This occurs since the purpose of using data fusion schemes is to collate correlated measurements to improve the detection of a phenomenon, which in the considered case is the presence of a signal in the sensed channel. Therefore the more correlated are the nodes the better are the data fusion schemes performance, as observed when normalizing the  $C_{df}$  in regard to the  $C_r$ , as depicted in Figure 4.28.

In Figure 4.27(b) it is depicted the False Capacity, and as expected  $1 - C_r$  increases with the increase of the average correlation index, this behavior is followed by the  $FC_s$ , although when the average correlation index is above 0.4, i.e. when there is a high degree of correlation, the  $FC_s$  growth rate decreases.

To further illustrate the dependence of the Capacity and False Capacity in Figure 4.28 are depicted respectively the normalized Capacity and normalized False Capacity.

From Figure 4.28(a) it can be seen that the  $\bar{C}_s$  remains almost the same independently of the average correlation index, while when considering the case of  $\bar{C}_{df}$ , for both fusion rules, there is an increase on the achieved capacity with the increase of the average correlation index. Also, the ACR allows for an higher perceived capacity than the OR rule.

The perceived capacity in the case of the data fusion schemes is proportional to the global probability of false alarm,  $GP_{fa}$ . Then it can be concluded that the reason why the adaptive rule  $C_{df}$  is higher than the  $C_{df}$  of the OR rule is because the adaptive rule allows to achieve a lower  $GP_{fa}$ .

The  $C_s$  is higher than the  $C_{df}$ , not due to the individual  $p_{fa}$ , but instead because in the case of the data fusion when there is enough local detectors experiencing and detecting the channel as occupied then after the data fusion the fusion center decides that all the local detectors are experiencing the local channel as occupied. This causes the previously mentioned loss of the diversity information which the consequence is a lower perceived capacity.

From Figure 4.28(b) it can be seen that in all cases the Normalized False Capacity (NFC) decreases with the increase of the average correlation index. Note that the False Capacity (FC) as defined relates to the probability of missed detection. This can be confirmed by observing that the NFC for the  $FC_s$  is higher than the  $FC_{df}$ , since the purpose of using data fusion schemes is to decrease the probability of occurring missed detections.

From Figure 4.28, it is observed that although the sensing without data fusion achieves a higher perceived capacity, it also achieves a higher perceived FC. From the analysis in this subsection it can be seen that the use of data fusion although reducing substantially the perceived capacity, also minimizes the perceived FC.

This occurs because the probability of detection and false alarm are dependent of each other; in fact it is possible to express them as a function of each other, as discussed previously. Therefore, as seen in the previous plots, by minimizing one the other is also minimized, since their relationship is of direct proportionality, although this relationship can be altered so that they become more robust against the effect of the other.

The DF schemes employed, perform the data fusion of the sensing results of all the participating local detectors, so hypothetically by using a subset of

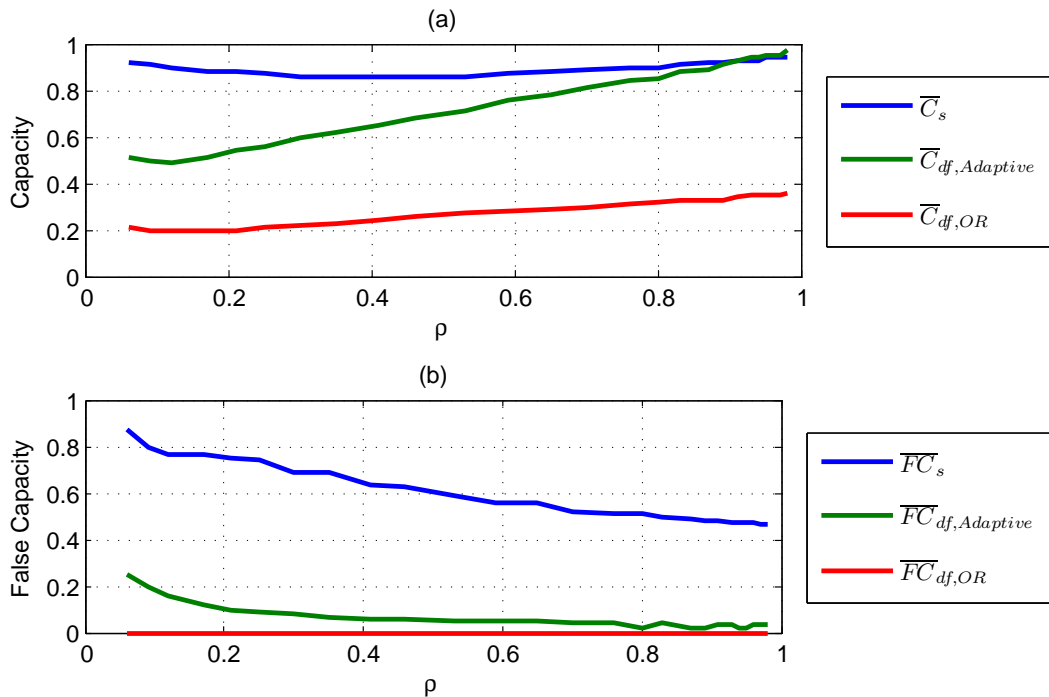

Figure 4.28: (a) Normalized Capacity and (b) Normalized False Capacity versus average local detectors experienced correlation

these nodes to perform the data fusion, it might be possible to increase the achieved capacity while minimizing the FC. This will be made apparent in the next sub-section, where the effect of the number of local detectors on the system perceived capacity is analyzed.

### 4.7.3 Effect of Number of Network Nodes on System Capacity

In this subsection the effect of varying the number of local detectors participating in the CSS is analyzed. The simulation parameters are the same as in the previous subsection, and the only difference is that here the average correction index is set to be 0.2, while varying the number of local detectors.

From Figure 4.27 it can be seen that the potential capacity,  $C_r$ , achievable by the CSS mechanism decreases with the increase of the average correlation index, i.e. the more correlated are the nodes the lower is the probability of the nodes to be experiencing different conditions, leading to less opportunities to

find available resources. The potential capacity is therefore a function of the spatial diversity degree.

In Figure 4.29 are depicted the Capacity and False Capacity versus the number of network nodes,  $c$ , respectively. From Figure 4.29(a) it is observed that  $C_s$  is constant when increasing the number of nodes, while the  $C_{df}$  decreases. The decrease of  $C_{df}$  is explained by the data fusion reducing the spatial diversity, and therefore the more nodes are performing data fusion, the less is the perceived capacity. The increase of the number of nodes leads to an increase of the overall probability of false alarm on data fusion schemes, which causes the system's perceived capacity to decrease. This becomes evident when considering the OR rule, since in this scheme the probability of false alarm increases with the number of nodes participating in the data fusion, as discussed before.

From Figure 4.29(b) is observed that the  $FC_s$  is constant with respect to the increase of the number of nodes, while the  $FC_{df}$  decreases with the number of nodes, which is explained by the decrease of the missed detection probability. This occurs because the purpose of using data fusion schemes is to increase the chances of performing a detection, which is what is observed in Figure 4.29(b).

The study presented in this subsection confirms the hypothesis formulated before, that the use of a lower number of nodes in the data fusion increases the system's perceived capacity, although it also increases the false capacity.

#### 4.7.4 Effect of Channel Occupation on System Capacity

In the previous sub-sections it was observed how the system perceived capacity varies with the average correlation index and with the number of nodes. In this subsection the effect of varying channel occupation statistics is considered. The simulation parameters are the same as in the previous subsections except that it is considered the  $\rho$  to be 0.2 and 0.5 with variable signal source duty cycle.

In Figure 4.30 is plotted the Capacity and FC versus the signal duty cycle. In Figure 4.30(a) it can be observed that the perceived capacity decreases with the increase of the channel occupation as expected, since if the channel is occupied an higher percentage of the time, then it is expected that the potential system's capacity will be lower. The reason the  $C_r$  is not 0 when the duty cycle is 1 because that some of the local detectors are outside the coverage of the transmitter, i.e. the signal is below the SNR detection threshold, so even if the transmitter is active these local detectors can still experience the channel as

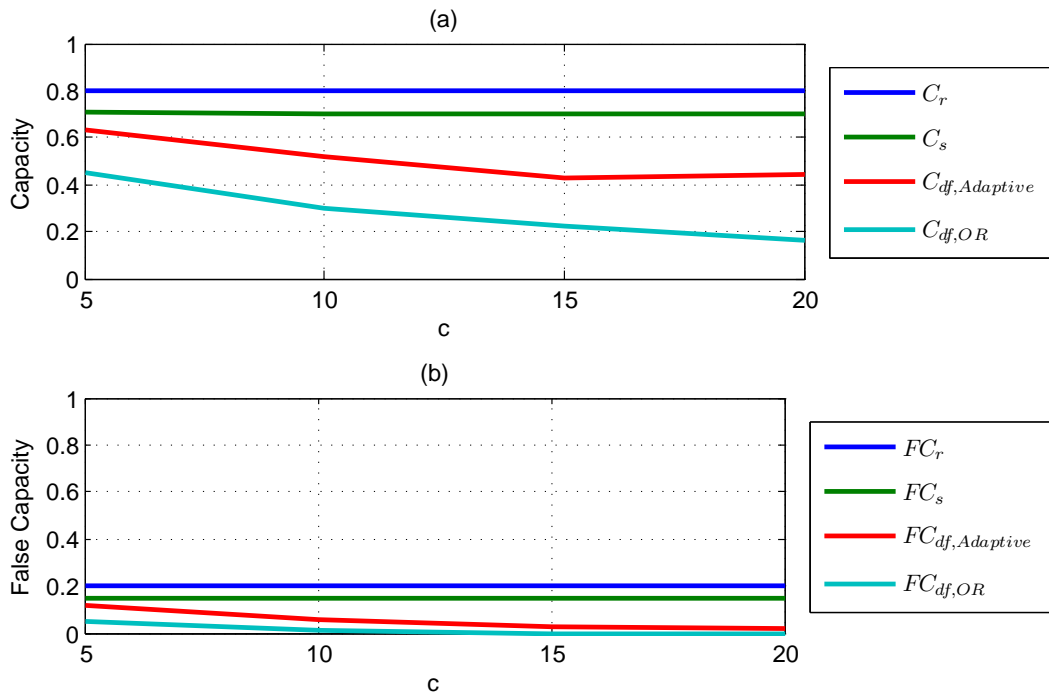

Figure 4.29: (a) Capacity and (b) False Capacity versus number of local detectors

free. The opposite trend can be seen in Figure 4.30(b), where the FC increases with the channel occupation, which is expected since a missed detection, can only occur if there is a signal being transmitted.

It should also be noted that although the perceived and potential capacity decreases linearly, its inclination is dependent on the environment average correlation. This can be observed by comparing Figure 4.30 with Figure 4.31.

#### 4.7.5 Considerations on how to increase System Capacity

From the analysis performed in the previous subsections it can be concluded that the environment correlation affects the potential capacity achievable by a CSS mechanism. The effect depends on how the sensing results are used, from the analysis it can be seen the capacity is higher when not using data fusion schemes while the false capacity is lower when using data fusion schemes.

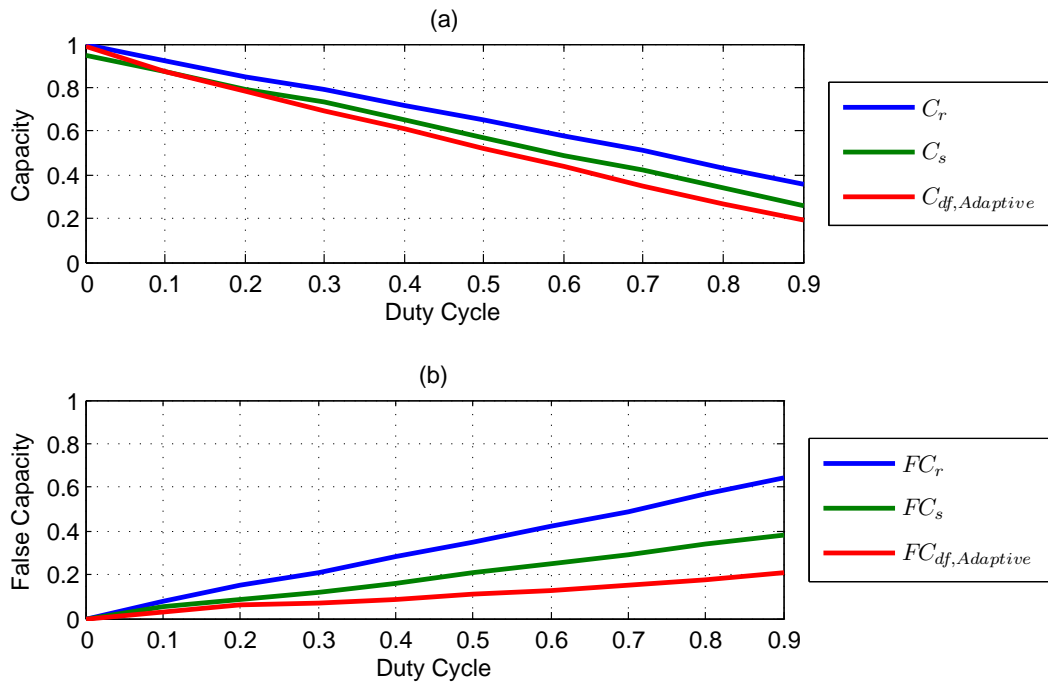

Figure 4.30: (a) Capacity and (b) False Capacity versus channel occupation,  $\rho = 0.5$  and  $c = 20$

Another observation is that the increase of the number of local detectors participating in a data fusion scheme reduces the perceived Capacity, while also reducing the FC. From this study the main conclusion drawn is that by using a lower number of local detectors in the data fusion it might be possible to achieve a higher perceived capacity, while the minimization of the FC will depend of the data fusion scheme in place.

Therefore, it is expected that if one groups together the local detectors in different sub-sets according with their correlation, then most likely the perceived capacity will be maximized while the FC will be minimized. The capacity gain from performing the division of the local detectors in sub-sets will of course depend on how correlated the local detectors are with each other.

In this section it was analyzed how the perceived capacity of a CSS mechanism behaves, according to the experienced environment correlation, channel occupation and number of cooperating local detectors. The analysis was made based on the defined metrics which characterize the perceived capacity and FC achieved by the studied schemes on all parts of the data fusion chain.

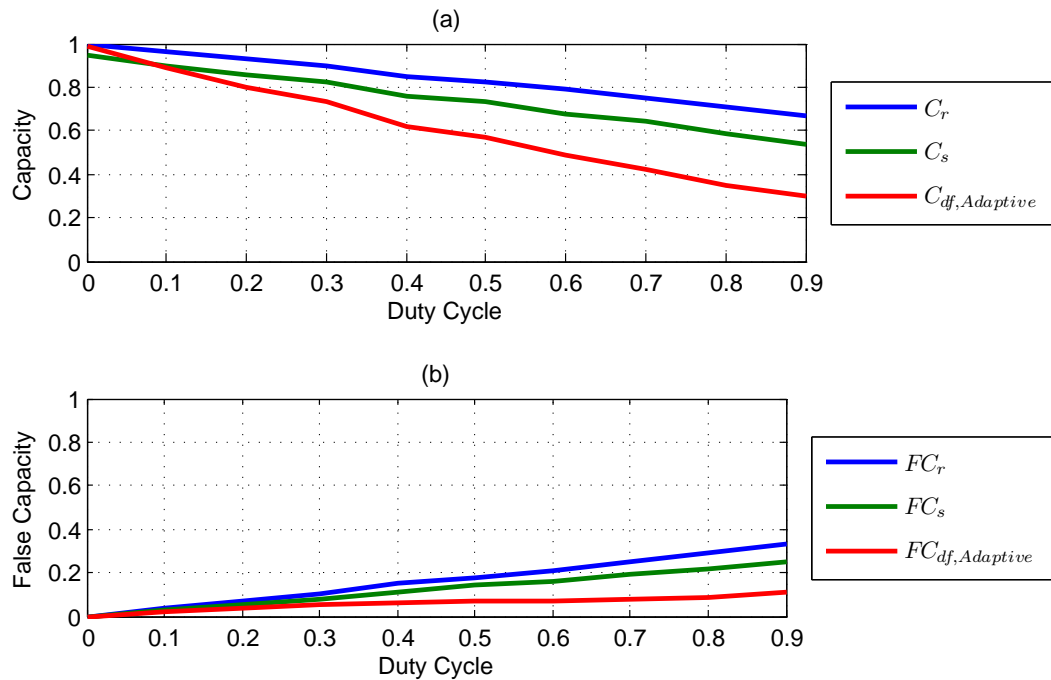

Figure 4.31: (a) Capacity and (b) False Capacity versus channel occupation,  $\rho = 0.2$  and  $c = 20$

In the next section a data fusion algorithm which groups the local detectors in sub-sets and then performs the data fusion within each one of these, is introduced.

## 4.8 Cluster based Adaptive Counting Rule

As discussed in the previous section, it might be possible to improve the network perceived capacity by gathering the LDs in different clusters, and then perform the data fusion individually at each cluster of LDs, as illustrated in Figure 4.32.

As a proof of concept consider the plot in Figure 4.33, where it is depicted the Capacity ( $C$ ) and FC at the different levels of the parallel data fusion chain. The metrics of interest are the  $C_{df}$ ,  $C_{df,PC}$ ,  $FC_{df}$  and  $FC_{df,PC}$ , which measure the  $C$  and  $FC$  perceived by using the MACR normally and by dividing the LDs in clusters, respectively. In the latter case, the LDs were grouped into two clusters, and the division method was given by a SNR threshold,  $SNR_{Thrs}$ , where any LD experiencing a SNR below that threshold was assumed to be



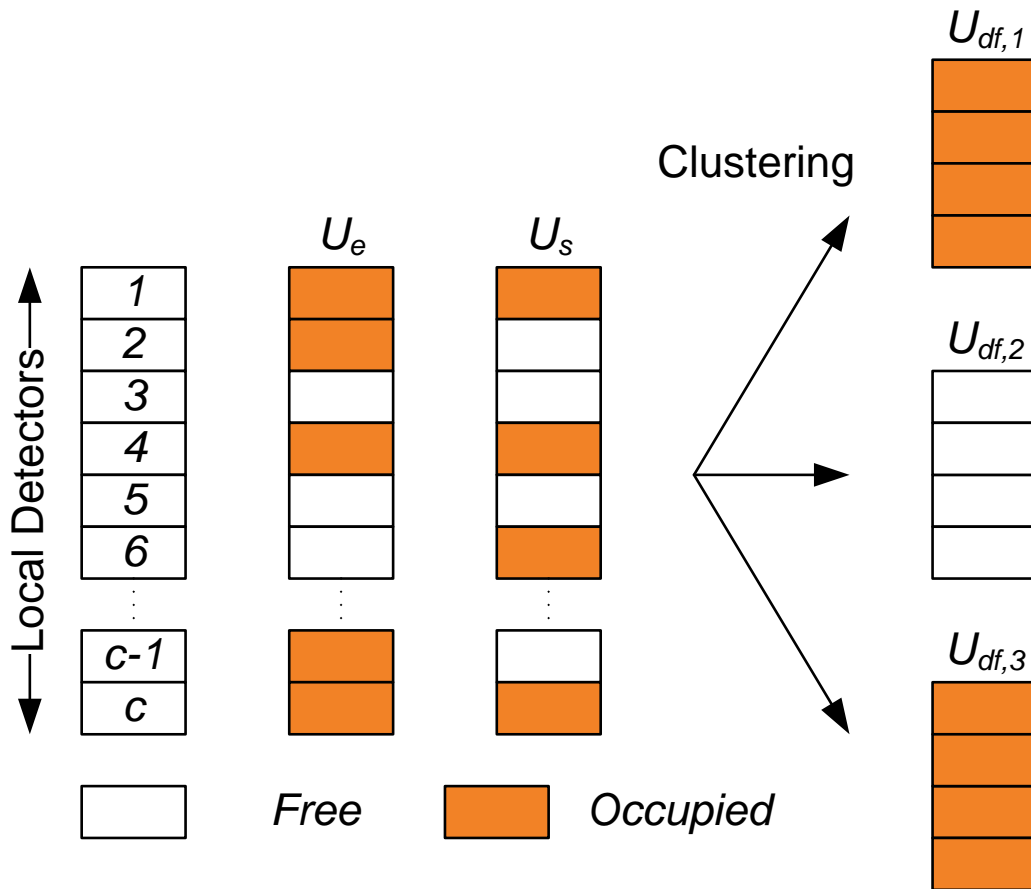

Figure 4.32: Clustering of LDs illustration

experiencing the channel as vacant. The motivation for defining such threshold, is that it is expected that below a certain  $SNR_{Thrs}$  it does not make sense to consider the channel to be occupied, since the amount of interference that the node associated to the LD would experience from the signal source can be neglected. This assumption is done from the CRN side, i.e. it does not consider the minimization of the interference of the CRN in the primary network and therefore this approach might not be applicable in some scenarios, where the goal is to ensure that the CRN does not interfere with the primary network. It should be noted that the purpose of this algorithm is to identify the maximum number of available opportunities for the CRN to use, and whether these will be used or not will depend on the access control mechanism in place at the CRN.

From the plot in Figure 4.33 it can be seen that it is worthwhile to group the LDs in clusters. The main challenge is to identify which information should

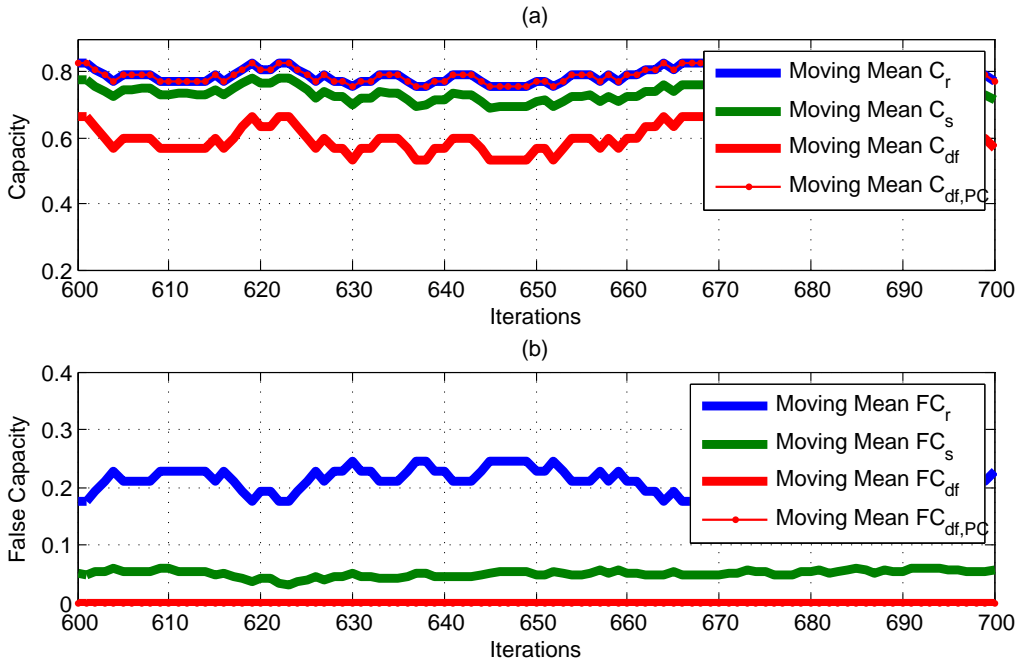

Figure 4.33: Proof of concept for the use of clustering in data fusion,  $c = 40$

be used as basis to perform the clustering process, since the information about the  $SNR_{Exp}$  is not available at the fusion center, as discussed previously. The alternative source of information found was the observed correlation between the LDs local decisions over time. The issue with this source of information is that the LDs are not perfect, i.e. their  $p_d < 1$  and their  $p_{fa} > 0$ , and therefore the LDs will most likely never be fully correlated. Therefore there is a need to find define a correlation threshold which translates to the considered  $SNR_{Thrs}$ .

The correlation can be measured with either the  $\rho$  or the  $\phi$  correlation coefficients. To analyze the viability of using these metrics, consider the plots in Figure 4.34, where it is depicted the variation of the correlation coefficients  $\rho$  and  $\phi$  in regards to the SNR experienced,  $SNR_{Exp}$ , by a pair of LDs in two different scenarios is depicted. In the first scenario, the blue curve, the pair of LDs have the same performance, i.e. they have the same  $p_d$ , which is dependent on the  $SNR_{Exp}$ . In the second scenario, the red curve, in one of the LDs the  $p_d$  is same in regards to the minimum  $SNR_{Exp}$ , while in the other LD the  $p_d$  varies with the  $SNR_{Exp}$ . In Figure 4.34(c) is plotted the relationship between the  $p_d$  and  $SNR_{Exp}$ , which was obtained following the Energy Detector (ED) model discussed in Chapter 2.

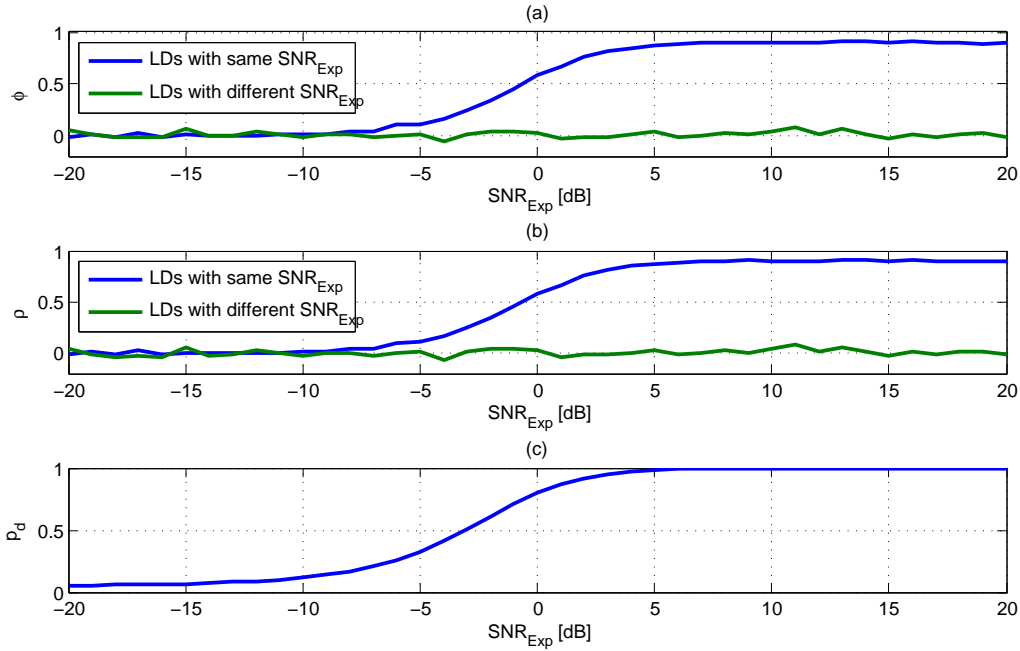

Figure 4.34: (a)  $\phi$  (b)  $\rho$  coefficients between the decisions of two LDs, with signal duty cycle of 0.5 and the LDs  $p_{fa} = 0.05$ , (c)  $p_d$  versus  $SNR_{Exp}$

In the first scenario, it can be seen that both correlation coefficients are higher than 0.5 only when the  $SNR_{Exp} > 0dB$ , which from the plot in Figure 4.34(c) translates to a  $p_d > 0.8$ . This observed relationship leads to that by using the correlation coefficients it is possible to identify whether a LD is experiencing a SNR above a certain level, if there at least one other LD which is also experiencing the same level of SNR. This pair matching will of course depend of the LDs performance.

In the second scenario, it can be seen that if the  $SNR_{Exp}$  by one of the LDs is low enough, then the correlation coefficients are always near zero. This is also observed in the first scenario, when the  $SNR_{Exp}$  by both LDs is low enough, where in the depicted scenarios low enough occurs when the  $SNR_{Exp} < -10dB$ . This occurs due to the mapping chosen in the local decisions in regards to the presence and absence of a signal, i.e. when the signal is absent,  $H_0$ , the local decision of the  $i^{th}$  detector is mapped as  $u_i = 0$ , while when the signal is present,  $H_1$ , the local decision of the  $i^{th}$  detector is mapped to  $u_i = 1$ .

Based on the previous observations, is now possible to define an algorithm which performs the grouping of LDs in clusters, by using the correlation coefficients of the LDs decisions over time as information source. For simplicity, it is considered that there is only one signal source, and therefore it is of interest to divide the LDs in only two clusters. The goal is that one of the clusters will include all the LDs which are experiencing a SNR above a pre-defined threshold, while the other cluster will include all the other LDs.

In Figure 4.35 is plotted, for the same the detector performance curve depicted in Figure 4.34(c), the evaluation of different  $\rho$  thresholds in regards to  $\phi$ , so to measure the performance of the classification mechanism which puts the LDs in one of two clusters. It can be observed that the  $\phi$  is maximized when the  $\rho \in [0.3, 0.4]$ , at least when all the LDs are dimensioned according to the considered performance curve.

To illustrate how the  $\rho$  threshold varies in regards to different performance curves, obtained by setting different  $p_d$  targets while maintaining the  $p_{fa} = 0.05$ , consider the plot in Figure 4.36. As observed in the plot the  $\rho$  threshold varies according to the performance of the LDs. The LDs performance range of interest is when the  $p_d \in [0.6, 1.0]$ , which translates to a  $\rho_{Thrs} \in [0.3, 0.6]$ .

The integration of the clustering algorithm with the MACR algorithm, for the case where there is only one signal source present, is listed in Algorithm 3. Where  $|L_\rho|$  represents the number of elements in the decrescent ordered list  $L_\rho$ . The  $SI$  is the sensing iteration counter, the  $SI_{min}$  is the minimum number of sensing iterations so that the  $\rho$  is statistically significant.  $C_1$  is the LD cluster where are stored the LDs which are experiencing a level of correlation above  $\rho_{Thrs}$ , which means that the LDs have a  $SNR_{Exp} \geq SNR_{Thrs}$ , while  $C_0$  is the cluster where all the uncorrelated LDs are stored. Note that the cluster decision,  $C_{df,0}$ , for  $C_0$  is  $H_0$ , because as seen in Figure 4.34 when a LD is uncorrelated with all others LDs then it means that the  $SNR_{Exp} < SNR_{Thrs}$ .

In Figure 4.37 is depicted the comparison over time using the capacity and false capacity metrics defined in Section 4.7 for the case of no DF, with DF using the MACR, and the DF with clustering, where the indices  $df, PC$  and  $df, CC$  refer to perfect clustering, as the one depicted in Figure 4.33, and the correlation based clustering, as the one defined by Algorithm 3 with a  $\rho_{Thrs} = 0.35$ , respectively. As seen from the results the proposed correlation based clustering algorithm is able to achieve the same performance of the perfect clustering algorithm.

**Algorithm 3** MACR integrated with single source clustering algorithm

---

```

if  $SI < SI_{min}$  then
  Group LDs in one cluster
  Perform the Data Fusion using Algorithm 2
else
  for all  $i, j$  LD pairs when  $i \neq j$  do
    Compute  $\rho_{ij}$  from local decisions  $u_i$  and  $u_j$  and  $L_\rho \leftarrow \rho_{ij}$ 
  end for
  while  $|L_\rho| > 0$  do
    Remove  $\rho_{ij}$  from the head of  $L_\rho$ 
    if  $i, j \notin C_1$  then
      if  $\rho_{i,j} \geq \rho_{Thrs}$  then
         $C_1 \leftarrow i, j$ 
        if  $i, j \in C_0$  then
          Remove  $i, j$  from  $C_0$ 
        end if
      else if  $i, j \notin C_0$  then
         $C_0 \leftarrow i, j$ 
      end if
    else
      if  $\rho_{i,j} \geq \rho_{Thrs}$  then
        if  $i \notin C_1$  then
           $C_1 \leftarrow i$ 
          Remove  $i$  from  $C_0$ 
        else
           $C_1 \leftarrow j$ 
          Remove  $j$  from  $C_0$ 
        end if
      else if  $i, j \notin C_0$  then
         $C_0 \leftarrow i, j$ 
      end if
    end if
  end while
  if  $|C_1| > 0$  then
    Obtain  $C_{df,1}$  from Algorithm 2
  end if
  if  $|C_0| > 0$  then
     $C_{df,0} = H_0$ 
  end if
end if

```

---

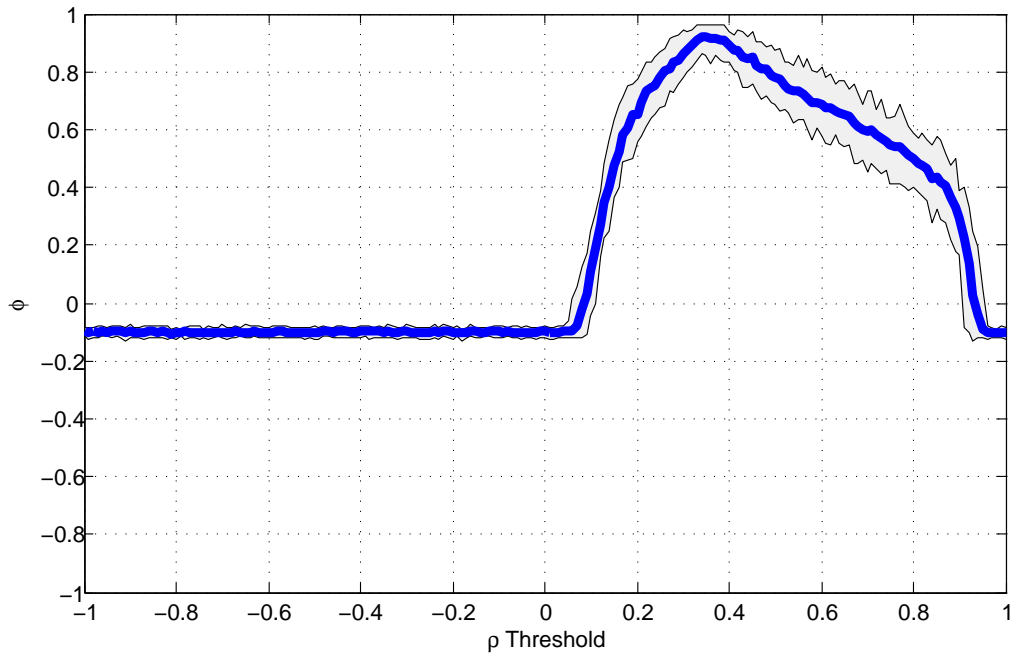
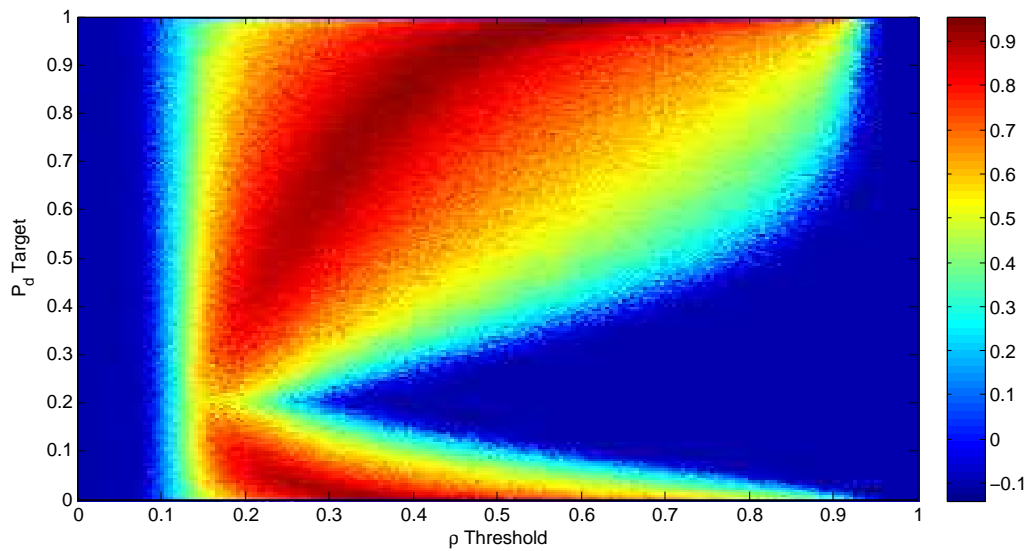
Figure 4.35:  $\rho$  threshold variation evaluated through  $\phi$ Figure 4.36:  $\phi$  variation in regards to  $\rho_{Thrs}$  and  $p_d$  target, when  $p_{fa}$  target is 0.05,  $c = 100$  and the  $SNR_{Thrs} = -5dB$ 

In Figure 4.38 is depicted the variation of the  $k$ -threshold of the MACR without clustering and with perfect and correlation based clustering. It can

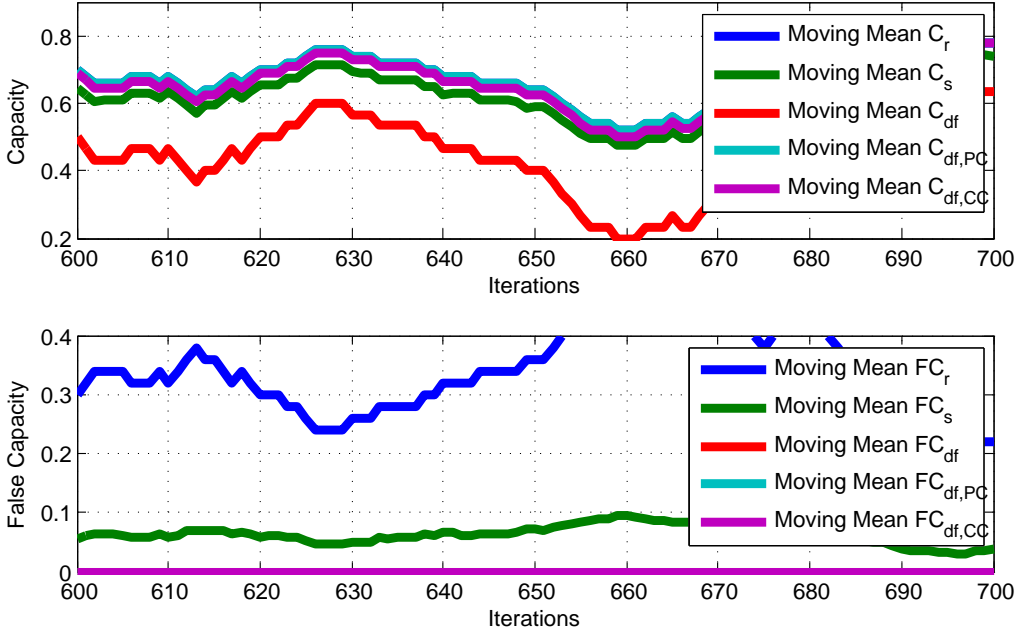

Figure 4.37: Non and clustering based data fusion algorithms comparison

be observed that all algorithms adapt the  $k$ -threshold at the same speed. Although it should be noted that while the simple MACR deals with all the  $c$  LDs, the MACR with clustering work with a lower number of LDs, which means that in relative terms the  $k$ -threshold is higher in the MACR with clustering than the simple one.

Now is the clustering algorithm is generalized to the case where there are multiple signal sources. The integration of the generalized clustering algorithm with the MACR algorithm is listed in Algorithm 4. Where  $|L_\rho|$  represents the number of elements in the decrescent ordered list  $L_\rho$ . The  $SI$  is the sensing iteration counter, the  $SI_{min}$  is the minimum number of sensing iterations so that the  $\rho$  is statistically significant.  $C_h$  is the  $h^{th}$  cluster and  $C_0$  is the cluster where all the uncorrelated LDs are stored. Note that the cluster decision for  $C_0$  is  $H_0$ , because as seen in Figure 4.34 when a LD is uncorrelated with all others LDs then it means that the  $SNR_{Exp}$  by the LD is below the  $SNR_{Thrs}$ .

Intuitively with the Algorithm 4 the LDs which experience similar conditions will be grouped together and therefore it will be possible to maximize the detection of the presence of a signal, while ensuring that LDs which are not experiencing the presence of the signal will be grouped together and therefore eliminating the occurance of false alarms.

---

**Algorithm 4** MACR integrated with Generalized Clustering Algorithm

---

```

if  $SI < SI_{min}$  then
  Group LDs in one cluster
  Perform the Data Fusion using Algorithm 2
else
  for all  $i, j$  LD pairs when  $i \neq j$  do
    Compute  $\rho_{ij}$  from local decisions  $u_i$  and  $u_j$  and  $L_\rho \leftarrow \rho_{ij}$ 
  end for
  while  $|L_\rho| > 0$  do
    Remove  $\rho_{ij}$  from the head of  $L_\rho$ 
    if  $i, j \notin \forall_h C_h$  then
      if  $\rho_{i,j} \geq \rho_{Thrs}$  then
        Create cluster  $C_h$  and add  $i, j$ 
        if  $i, j \in C_0$  then
          Remove  $i, j$  from  $C_0$ 
        end if
      else if  $i, j \notin C_0$  then
         $C_0 \leftarrow i, j$ 
      end if
    else
      if  $\rho_{i,j} \geq \rho_{Thrs}$  then
        if  $i \notin \forall_h C_h$  then
          Add  $i$  to  $C_h$  for which  $j \in C_h$ 
        else
          Add  $j$  to  $C_h$  for which  $i \in C_h$ 
        end if
      if  $i, j \in C_0$  then
        Remove  $i, j$  from  $C_0$ 
      end if
      else if  $i, j \notin C_0$  then
         $C_0 \leftarrow i, j$ 
      end if
    end if
  end while
  for all  $C_h$  when  $h > 0$  do
    Obtain  $C_{df,h}$  from Algorithm 2
  end for
  if  $|C_0| > 0$  then
     $C_{df,0} = H_0$ 
  end if
end if

```

---



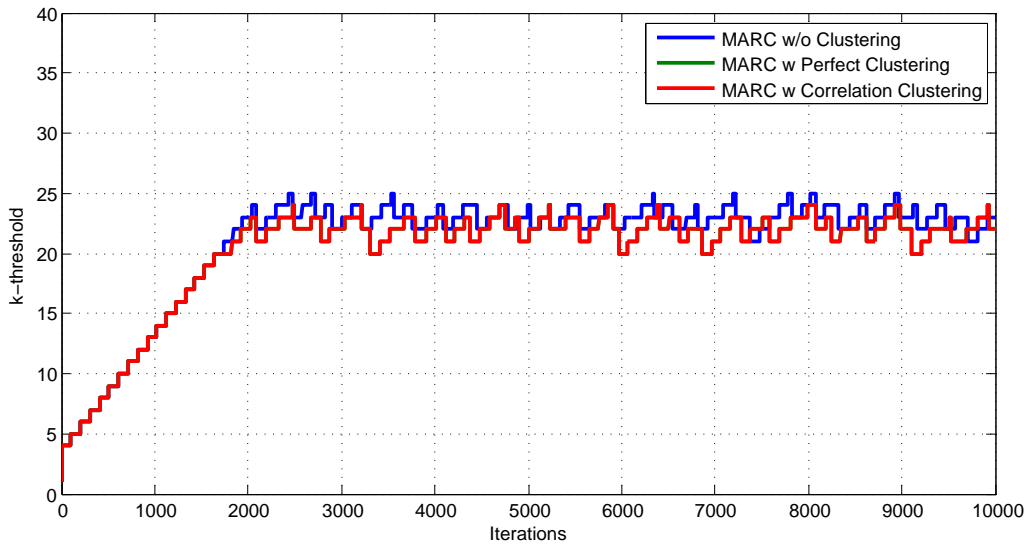

Figure 4.38:  $k$ -threshold variation over time, with  $c = 40$  and  $OW = 100$

In Algorithm 4 is expected that the number of clusters will not be higher than the twice the number of signal sources. This is expected because in the extreme case for each signal source the LDs can potentially be separated into a cluster which gathers the LDs which are experiencing that same signal. The Algorithm 4 as not been implemented at this point, so further analysis will be given in future work.

## 4.9 Conclusions

This chapter was focused on the *Local Decisions Fusion* step of the CSS flow. It was considered the case where the data fusion follows a two level parallel distributed detection system, which consists of a number of LDs connected to a fusion center. It was assumed that each LD reaches a local decision in each sensing session, of the hard decision type, i.e. the result of the decision is encoded in just one bit, which is then transmitted to the fusion center. At the fusion center its considered that the data fusion is performed over the received local decisions using a fusion rule of the counting rule type, i.e. that counts the number of LDs which have decided that a signal is present in the sensed channel and then compare that number with a decision threshold, which in case where it is higher than the threshold then the global decision is that a signal is present, otherwise that is absent.

The chapter starts with a detailed motivation for the use of counting rules as the fusion rules in place for the data fusion. Then a theoretical formulation of the counting rules is given, and how the performance of the data fusion is affected when varying its implicit parameters, such as the local probability of detection, false alarm and the number of LDs in place.

Two performance evaluation metrics  $\phi$  and  $\epsilon$  were introduced. The counting rules were then evaluated using these performance metrics, first in general without considering the underlying LD model, then when considering the LD model and finally when the signal duty cycle varies.

The case where the LDs are non-identical is considered, which then gives rise for the motivation of using an ACR mechanism, which adapts the  $k$ -threshold based on the experienced conditions of the LDs using the feedback when the CRN tries to access the sensed channel. The proposed ACR mechanism is then further refined to be more adaptable, and depend less on a-priori set thresholds.

The concept of Capacity and False Capacity in the spectrum sensing context is introduced, and then an evaluation of both capacities along the data fusion chain is given. The Capacity metric measures the effect of the exposed node problem, while the False Capacity metric measures the effect of the hidden node problem. In this evaluation it was considered the correlation between the LDs, the number of LDs participating in the data fusion and the effect of the signal duty cycle.

The Capacity and False capacity study gave insights on how the data fusion process can be improved, so to increase the amount of perceived available resources in the sensed channel. Based on these insights a Cluster based Adaptive Counting Rule is then proposed, on which the LDs that experience similar signal conditions are grouped in clusters and where the data fusion is done separately for each cluster. The proposed clustering algorithm uses the correlation between the local decisions of the LDs over time to select the cluster where each LD should go. It was observed, in the case where there is only one signal source, that the proposed algorithm was able to achieve the same level of performance in terms of Capacity and False Capacity when compared to the perfect clustering algorithm where full information about the conditions at each of the LDs was available at the fusion center. In the case of multiple signal sources a generalized clustering algorithm was proposed, but its evaluation was left for future work.

It should also be noted that it was assumed that the reporting channel is noiseless. Therefore it would be of interest for future work to consider

the impact of a noisy reporting channel in the performance of the proposed schemes.

## References

- [1] Ian F. Akyildiz, Brandon F. Lo, and Ravikumar Balakrishnan. Cooperative spectrum sensing in cognitive radio networks: A survey. *Physical Communication*, 4(1):40–62, 2011.
- [2] D. Cabric, A. Tkachenko, and R. W. Brodersen. Experimental study of spectrum sensing based on energy detection and network cooperation. In *Proceedings of the first international workshop on Technology and policy for accessing spectrum*, TAPAS '06, New York, NY, USA, 2006. ACM.
- [3] Harald Cramer. *Mathematical Methods of Statistics*. Princeton University Press, 1946.
- [4] E. Drakopoulos and C.-C. Lee. Optimum multisensor fusion of correlated local decisions. *IEEE Transactions on Aerospace and Electronic Systems*, 27(4):593–606, July 1991.
- [5] Andrea Goldsmith. *Wireless Communications*. Cambridge University Press, New York, NY, USA, 2005.
- [6] Way Kuo and Zuo Ming. *Optimal Reliability Modeling: Principles and Applications*. Wiley, 2002.
- [7] Ali M. and Rushdi. Utilization of symmetric switching functions in the computation of k-out-of-n system reliability. *Microelectronics Reliability*, 26(5):973 – 987, 1986.
- [8] Alexander M. Mood. *Introduction to the Theory of Statistics*. McGraw-Hill Series in Probability and Statistics. McGraw-Hill, 3rd edition, April 1974.
- [9] H. Urkowitz. Energy detection of unknown deterministic signals. *Proceedings of the IEEE*, 55(4):523–531, April 1967.
- [10] Pramod K. Varshney. *Distributed Detection and Data Fusion*. Springer-Verlag New York, Inc., Secaucus, NJ, USA, 1st edition, 1996.

- [11] Luis Vergara. On the equivalence between likelihood ratio tests and counting rules in distributed detection with correlated sensors. *Signal Processing*, 87(7):1808 – 1815, 2007.



# 5

## Node Selection Mechanisms

### 5.1 Introduction

In Figure 5.1 is given an overview of the Cooperative Spectrum Sensing (CSS) mechanism considered in this thesis, where as discussed in the previous chapters, the goal of the CSS mechanism is to ensure that all Cognitive Radio Network (CRN) nodes have updated and synchronized information about the state of the targeted spectrum.

In this chapter is discussed the role of the Node Selection (NS) step, which the purpose is to control how the Local Detectors (LDs) cooperate in regards to the Spectrum Sensing (SS). As stated in Chapter 2, the NS step plays a key role on the performance of the CSS since it can influence the cooperative gain as well as be used to address the possible overhead issues, although it should be noted that these gains and losses are not explicitly considered in this chapter. The focus on this chapter is instead on how to select which channels should each of the LDs sense at each sensing session, and therefore on which mechanism can accomplish this.

The NS mechanism proposed in this chapter, is described in a centralized and in a decentralized approach, as proposed in [4] and [3], respectively. In the centralized approach, there is a central entity, normally where the Fusion Center (FuC) is co-located, which performs the NS, while in the decentralized

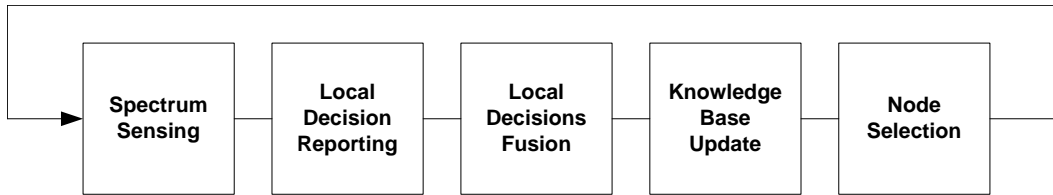

Figure 5.1: Distributed cooperative spectrum sensing flow

approach each CRN node performs the NS by itself. From a distributed protocol standpoint, both the centralized and decentralized approaches follow the protocol descriptions stated in Chapter 3.

The NS mechanism here proposed follows the same lines as an orchestration mechanism in computing, which the purpose here is the automated arrangement and coordination of the LDs among the monitored spectrum, so to maximize the gain of using cooperation, which in this case translates in identifying has many available resources as possible, while taking in account that the number of LDs available is a finite resource. In this chapter it is introduced the orchestrating mechanism which distributes the LDs across the monitored spectrum along consecutive SS sessions. The proposed NS mechanism, selects which channels should each Local Detector (LD) sense through the use of a scheduling mechanism, which belongs to the class of utility based schedulers proposed by Kelly [2]. It is assumed that the utility function of the scheduler is somehow related to the duty cycle of the primary signal in each channel. Therefore in the proposed mechanism the observed duty cycle serves as input for the scheduling metric, and so the mechanism tends to prioritise the sensing of channels which have an observed lower signal duty cycle, since these channels are the ones that most likely will have resources available to be used by the CRN.

In the following section is analyzed the performance gain in terms of potential capacity, as defined in Chapter 4, when the LDs are able to sense more than one channel at a time.

## 5.2 Multi Channel Sensing

Here is considered the case where the LDs are able to sense more than one channel at each sensing iteration. The analysis depicted refers to the potential gains and losses in regards to potential capacity and false capacity, and does not

consider the increased hardware or algorithmic complexity that such solutions would imply.

To quantify the performance, the metrics defined in Chapter 4 for the potential capacity and false capacity need to be extended to account the case where the CRN is monitoring multiple channels.

The multichannel potential capacity of the set of considered LDs, given by  $MC_r$ , is defined as,

$$MC_r = \frac{\sum_{j=1}^M \sum_{i=1}^N U_{e,ji}}{MN} \quad (5.1)$$

where  $U_{e,ji}$  is the experienced channel state of the  $i^{th}$  local detector at the  $j^{th}$  channel and  $N$  is the number of LDs. This metric allows to measure the fraction of LDs that are experiencing free channels, i.e. before the SS takes place.

The multichannel potential false capacity of the set of considered LDs, given by  $MFC_r$ , is defined as,

$$MFC_r = 1 - MC_r \quad (5.2)$$

where  $MC_r$  is the multichannel potential capacity of the set of considered LDs. This metric allows to measure the fraction of LDs that can potentially decide the channels to be free when they are not, i.e. before the SS takes place.

In the plots of Figure 5.2 are shown the normalized potential Multichannel Capacity (MC) and Multichannel False Capacity (MFC) achievable when using LDs which are able to sense one, two and three channels in each sensing session in regards to the case where the LDs are able to sense  $m$  channels in each sensing session. These results were obtained through a monte carlo type simulation, where the duty cycle of each of the monitored channels can be within  $[0, 1]$ , and as been obtained for each of the channels by drawing a random uniform variable,  $r \leftarrow U(0, 1)$ .

The results show that there is a potential gain and loss by using LDs which are able to sense multiple channels in the same sensing session, as seen in plots in Figure 5.2(a) and Figure 5.2(b), respectively. It can also be observed that the growth of the gain in potential MC decreases with the increase of the number of channels that the LDs can sense in each sensing session. This is made evident by the concavity observed in the trend line associated with the potential MC and the convexity in the trend line associated with the potential MFC, for the case  $m = 5$ . Although, the same phenomenon is not observable in the case where  $m = 10$ , since the number of channels that the LDs need to



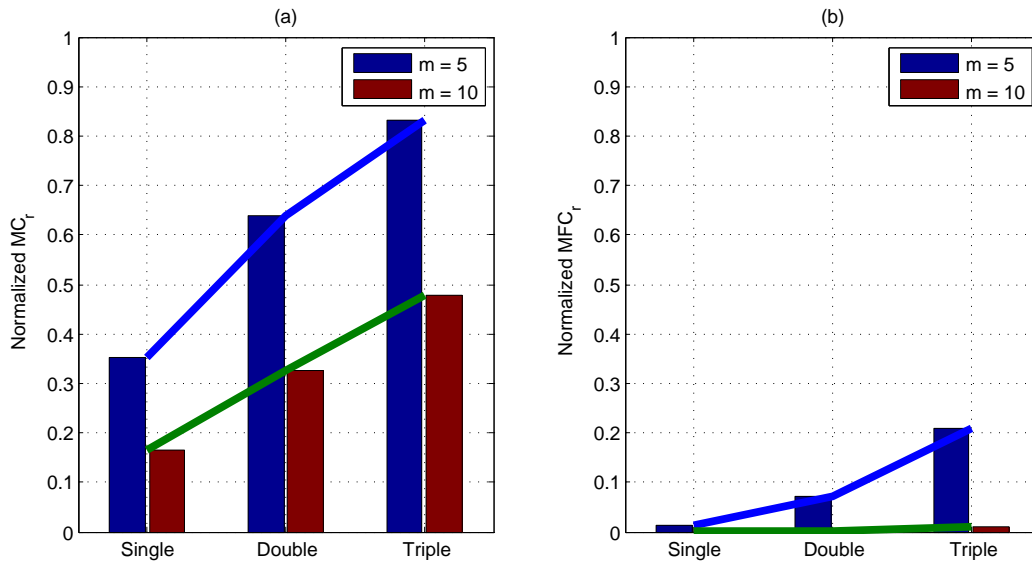

Figure 5.2: Comparison between normalized  $MC_r$  and  $MFC_r$  for LDs able to sense multiple channels, for  $m = 5$  and  $m = 10$

be able to sense in each sensing session needs to be higher than three so that the same saturation in the gain is observed.

From the observations of the plots in Figure 5.2 it can be concluded that there is an observable gain in regards to the potential MC, although with an increase in the potential MFC, especially when the number of channels that each LD is able to sense in each sensing session approximates the number of monitored channels. This leads to the conclusion that the optimum number of channels that the LDs should sense per sensing session depends on the number of channel monitored.

The drawback, although not measured, is on the added hardware and signal processing complexity to the LDs, which leads to an higher cost, which will depend on the technology used to implement the LDs. In the remaining of the chapter is considered that each LD is able to sense only one channel in each sensing session, which therefore implies that the developed NS algorithms were not tested nor designed for a scenario where the LDs are capable of sensing multiple channels in each sensing session.

In the next section is presented the rationale for using the channel observed signal duty cycle as scheduling metric for the NS mechanism.

## 5.3 Node Selection Rationale

In the plots of Figure 5.3 is depicted a comparison between several NS strategies, in regards to the normalized MC and MFC.

The *optimum* NS mechanism assumes that there is full knowledge about the monitored channel states and whether the LDs are in range of the signal source for each of the monitored channels. The *optimum* NS matches the performance of the LD which is able to sense only one channel at a time, i.e. *single*, as depicted in the plots of Figure 5.2.

The *sequential* NS mechanism selects one of the monitored channels for the LDs to sense in each sensing session. The choice of the channel to sense is done sequentially, as done in a round robin scheme. Therefore in stationary conditions it would be expected that each of the channels have been sensed the same amount of times.

In the *random* NS mechanism, each LD is assigned randomly a channel to sense. This is performed by drawing a uniform random variable that is then used to select which channel the LD should sense, therefore each channel has the same probability of being selected to be sensed.

Finally, the *lower duty cycle* NS mechanism selects the channel that each LD should sense based on the monitored channel duty cycle and on the information of whether the LD is in range of each of the signal sources in each of the monitored channels. The selection is done by prioritizing the sensing of channels that have a lower duty cycle. The information about the monitored channels duty cycle can be estimated from the results of the sensing over time. While the information about whether the LDs are in range of each of the transmitters in each of the monitored channels can be obtained by using a data fusion algorithm as the one the proposed and described in Chapter 4.

Comparing the performance of each of the described NS mechanisms, it can be concluded that the mechanism that prioritises the sensing of the *lower duty cycle* channels presents an higher performance, when compared to the *sequential* and *random* NS mechanisms. It should be noted that this difference in performance will only be observed when there is enough information for the *lower duty cycle* NS mechanism, which can only occur after sufficient number of sensing sessions. Therefore in the beginning the *sequential*, *random* and *lower duty cycle* NS mechanism will have the same performance, but then over several sensing sessions, the performance of the *lower duty cycle* NS will increase. The results shown in the plots of Figure 5.3 for the *lower duty cycle* NS refer to the case where the information available has the highest quality

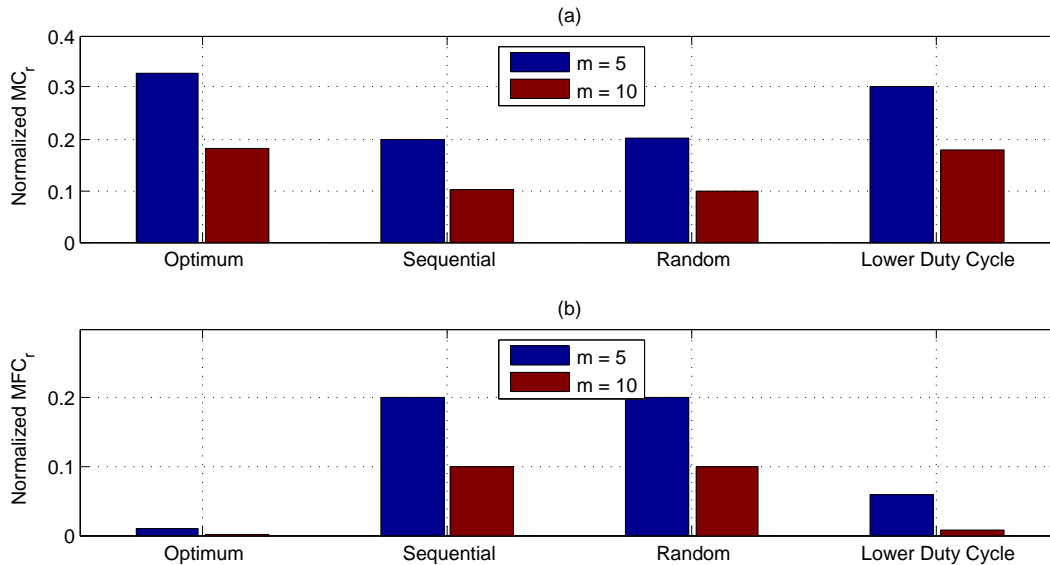

Figure 5.3: Comparison between NS strategies

possible, i.e. the estimation of the duty cycle and whether the LDs are in range of each of the transmitters is perfect.

These performance differences were expected since if the NS mechanism does not use any information about the monitored channels to select which channels should each LD sense, then it is expected that a mechanism that does use that information will present a higher performance. This also means that the *sequential* and *random* NS are simple to implement, while the other one requires more sophisticated techniques. In the remaining of this chapter is described how the *lower duty cycle* NS mechanism can be implemented.

In the following section is introduced the scheduling fundamentals of the NS proposed in this chapter.

## 5.4 Node Selection Fundamentals

The proposed NS mechanism is based on the Kelly scheduler [2], here described following the notation of [1].

Consider the case where  $M$  users are bidding for a share of a finite resource denoted as  $C$ . In the CSS context, the users are the channels being monitored, while the resources to distribute are the LDs.

Each  $m^{th}$  user has associated a utility function,  $U_m(d_m)$ , which determines the monetary value of any resource allocation,  $d_m$ , to the  $m^{th}$  user.

Consider now the triple  $(C, M, \mathbf{U})$ , where  $C > 0$ ,  $M > 1$ , and  $\mathbf{U} = [U_1, \dots, U_M]$ , as the utility system. The utility is measured in monetary units; therefore, if the  $m^{th}$  receives a resource allocation  $d_m$ , it must pay a price  $w_m$ , thus receiving a net payoff  $N_{PO}$ , given by,

$$N_{PO} = U_m(d_m) - w_m \quad (5.3)$$

Given any vector of utility functions  $\mathbf{U}$  the maximization problem can be expressed as the maximization of the aggregate utility, and can be defined as the triple  $(C, M, \mathbf{U})$  such that:

$$\begin{aligned} & \text{maximize } \sum_{m=1}^M U_m(d_m) \\ & \text{subject to } \sum_{m=1}^M d_m \leq C \\ & \quad \quad \quad d_m \geq 0 \end{aligned} \quad (5.4)$$

where  $d_m$  are the components of the non-negative vector of resource allocation  $\mathbf{d}$ . This vector  $\mathbf{d}$  can be computed, by considering that each  $m^{th}$  user submits a bid, denoted as  $w_m$ , to the resource manager, i.e. the CRN node responsible.

Then given the vector  $\mathbf{w}$ , defined as  $\mathbf{w} = [w_1, \dots, w_M]$ , the resource manager chooses and allocates  $d$ , according to,

$$d_m(w_m) = \begin{cases} \frac{w_m}{\sum_{k=1}^M w_k} C & , \text{ if } w_m > 0 \\ 0 & , \text{ if } w_m = 0 \end{cases} \quad (5.5)$$

Considering that the users choose the bid based on the maximization of the  $N_{PO}$ , then according to [1], the allocation of the resources is fully efficient, reaching the maximum possible aggregate utility.

Note that the  $U_m(d_m)$  is not defined here, and so is considered to be unknown. Revisiting the  $N_{PO}$ , it can be stated, in a CSS context, that the  $N_{PO}$  will be maximized when the number of received LDs will match the number of identified resources. Where the number of identified resources follows the same definition given in Section 4.7, i.e. the number of LDs that are experiencing the channel as free, which might be due to the absence of signal or because the LDs are outside the signal source range, i.e. the  $SNR_{Exp} < SNR_{Thrs}$ . Intuitively when a channel has a lower observed duty cycle then potentially there will be more resources to be identified by sending an higher number of LDs there. For simplification, it is considered that the channel observed duty cycle, represents the behaviour of all signal sources operating in that channel,

excluding the CRN signal sources, i.e. the duty cycle measures the channel occupation in regards to the primary system.

So following the exposed nomenclature, the  $m^{\text{th}}$  channel bid  $w_m$  is equal to the remainder of signal source duty cycle,  $s_m$ , defined as,

$$s_m = 1 - dc_m \quad (5.6)$$

where  $dc_m$  is the duty cycle of the  $m^{\text{th}}$  channel. It is assumed that the signal source duty cycle is obtained through estimation, which can be accomplished by using one of the estimators defined in Appendix D.

In the next section are introduced the NS mechanism which apply the presented scheduling framework.

## 5.5 Node Selection Mechanism

The scheduling framework presented in the previous section is here applied to design both a centralized and decentralized NS mechanism.

In the centralized mechanism there is one CRN node responsible for the orchestration, but in a decentralized approach, there is not a single CRN node which is responsible for the orchestration. Therefore, to apply this scheduler to the decentralized case the Eq. 5.5 needs to be obtained indirectly, i.e. each of the LDs will select which channel to sense based on the bids received from their neighbouring LDs, and in the end the resource distribution will try to follow Eq. 5.5.

These algorithms assume that the duty cycle of the monitored channels is estimated over time, using the estimators defined in Appendix D, and that the information obtained over time from the *Cluster based Adaptive Counting Rule*, defined in Chapter 4, is available, such as the information about which LDs are out of range of the signal source in each of the monitored channels.

Note that the proposed algorithms follows the same structure as the one expressed through the use of a process calculus in Chapter 3.

### 5.5.1 Centralized Mechanism

In Algorithm 5 is listed the algorithm used to implement the centralized NS mechanism. At the system initialization, since it is assumed that there is no information *a priori* available about the state of the channels then the LDs

are assigned to sense a random channel, and from there start the orchestration mechanism based on the estimated information.

The allocation of the resources can be accomplished by either assigning all the LDs to the channel with the higher  $d_m$ , stated in the algorithm as Single Channel Assignment (SCA), or by assigning the number of LDs proportionally to the  $d_m$ , while ensuring that the LDs assigned to sense the channel are the ones that are more likely to experience the channel as vacant.

The SCA strategy is adequate when the CSS system has not yet acquired sufficient information about whether the LDs are in range of each of the signal sources at each of the channels. While the later assignment strategy should be used when that same information is reliable enough. According to the performance from the *Cluster based Adaptive Counting Rule*, defined in Chapter 4, the required information should have enough reliability when each channel has been sensed at least 100 times. Therefore the proposed NS mechanism performance improves over consecutive sensing sessions. The drawback is that this improvement will only occur if the system observed conditions does not change often, i.e. if the LDs are mobile most likely the NS will never be able to take advantage of higher performance given by the later LD assignment strategy due to not be able to acquire the required information with enough reliability fast enough.

## 5.5.2 Decentralized Mechanism

In Algorithm 6 is depicted the algorithm which accomplishes the distribution of the sensing nodes across the monitored channels in the decentralized case. As in the centralized algorithm, when the CSS system is initialized the LDs are assigned to sense a random channel. The Algorithm 6 runs simultaneously in each of the CRN nodes which act as LDs, allowing this decentralized system to achieve the same behaviour as the centralized algorithm.

Similarly to the centralized algorithm, the assignment of the LDs can be accomplished by either assigning all the LDs to the channel with the higher  $\|w_m\|$ , stated in the algorithm as SCA, or by trying to assign the number of LDs proportionally to  $d_m$ , which here is obtained by drawing a uniform distributed random variable and then match it with the minimum  $m$  where  $r < \|w_m\|_{CDF}$ . The assignment to channels where the LD will most likely experience the channel as vacant is prioritized. As stated in the algorithm the LD performs a number of trials to try to assign the LD to a channel that where the LD will most likely experience it as vacant.

**Algorithm 5** Centralized Node Selection Scheme

---

```

Receive Sensing Results from LDs
for every channel  $m$  do
  if channel  $m$  has been sensed then
    Compute  $s_{inst}$  according to data fusion scheme
  end if
  Compute  $\hat{s}_m$  and obtain  $w_m$ 
end for
for every channel  $m$  do
  Compute  $d_m(w_m)$ 
end for
if Single Channel Assignment then
  Allocate all LDs to the channel  $m \leftarrow \max(d_m)$ 
else
  for every channel  $m$  do
    Allocate  $\lfloor d_m \rfloor$  LDs to channel  $m$ 
    Prioritise LDs that are out of range of the signal source in channel  $m$ 
  end for
  if There are unassigned LDs then
    Allocate the remaining LDs to the channel  $m \leftarrow \max(d_m)$ 
  end if
end if

```

---

The SCA strategy, as in the centralized algorithm, is adequate when the CSS system has not yet acquired sufficient information about whether the LDs are in range of each of the signal sources at each of the channels. While the later assignment strategy should be used when that same information is reliable enough. The decentralized algorithm has the same drawbacks as the centralized in regards to the required number of sensing sessions to acquire enough information to be able to perform a reliable estimation of which LDs are in range of each of the signal sources at each of the monitored channels.

### 5.5.3 Implementation Constraints

Although both algorithms are possible to implement, there are some observed performance constraints, especially for the decentralized algorithm. In the decentralized algorithm it is not possible to know for certain what will be the number of LDs which will be sensing a given channel, therefore the Adaptive Counting Rule data fusion scheme, proposed in Chapter 4, will most likely perform worse than the case where the number of LDs is constant. Therefore,

**Algorithm 6** Decentralized Node Selection Scheme

---

```

Receive Sensing Results from Cluster Nodes
for every channel  $m$  do
  if channel  $m$  has been sensed then
    Compute  $s_{inst}$  according with fusion rule
  end if
  Compute  $\hat{s}_m$  and obtain  $w_m$ 
end for
Normalize the channel bids, i.e.  $\|w_m\| = w_m / \sum_m^M w_m$ 
if Single Channel Assignment then
  Select channel to sense with index  $m \leftarrow \max(\|w_m\|)$ 
else
  Compute  $CDF$ , i.e.  $\|w_m\|_{CDF} = \|w_m\| + \|w_{m-1}\|_{CDF}$ 
  Set  $Counter =$  Number of trials
  while  $Counter == 0$  do
    Generate random variable,  $r \leftarrow \text{Uniform}(0, 1)$ 
    Select the minimum  $m$  for which  $r < \|w_m\|_{CDF}$  is true
    if channel  $m$  signal source is out of the LD range then
      Select channel to sense with index  $m$ 
       $Counter = 0$ 
    else
       $Counter = Counter - 1$ 
    end if
  end while
end if

```

---

the centralized NS algorithm will most likely achieve an higher performance than the decentralized one.

The purpose of the decentralized NS mechanism is to give a higher robustness to the CSS scheme, since if in the centralized scheme the CRN responsible for the orchestration stops working then the CSS collapses, while in the decentralized in the case that some of the LDs withdraws, it will still be possible to continue with the CSS.

The centralized and decentralized NS schemes complement each other, since allowing the CRN to support both schemes is a viable way to increase the robustness of the CSS. So in the case where the CRN node responsible for the orchestration, by any reason, stops working the CRN can continue to perform the CSS by activating the decentralized NS scheme, until another CRN node



can be elected to act as the orchestrating node. Through this is possible to achieve uninterrupted CSS as long as there are at least two LDs.

## 5.6 Performance Comparison

The comparison of the proposed NS with the optimum and the random NS, both described in Section 5.3, is depicted in the plots of Figure 5.4.

As expected the proposed NS performs better in regards to the Random NS, although it is not able to reach the same performance as the Optimum NS. The performance of the proposed NS is higher than the Random NS since the proposed NS uses the information harvested along the consecutive sensing sessions, while the Random NS disregards that same information. The performance of the proposed NS is always lower than the Optimum NS because the information available to the algorithm is not enough to make the perfect assignment. It should be noted that the plots shown in Figure 5.4 for the proposed NS algorithms, show the case where there is enough information for the algorithms to work properly without the SCA, therefore the performance in the best case. It should also be noted that the performance of the decentralized NS is slightly lower than the centralized NS, this is due to the weighted random selection in the decentralized NS.

In the plots of Figure 5.5 is shown the comparison between the performance of the centralized and decentralized NS with and without the SCA active. The SCA should only be active when there is not enough information to perform a proper channel assignment, therefore this case represents the lower performance bound of the algorithm. While the case of when the SCA is inactive gives the upper bound of the algorithm, since it considers that the required information as been perfectly estimated. Therefore it is expected upon implementation the performance of the proposed algorithms will be within this interval.

## 5.7 Conclusions

In this chapter was shown why a proper NS is required for a CSS to work properly in a multi-channel scenario. This was done by showing through the use of the Potential Capacity and and False Capacity metrics, which quantify not only the performance of the proposed NS but also to give a measure of the performance achievable when the using the optimum multi-channel and

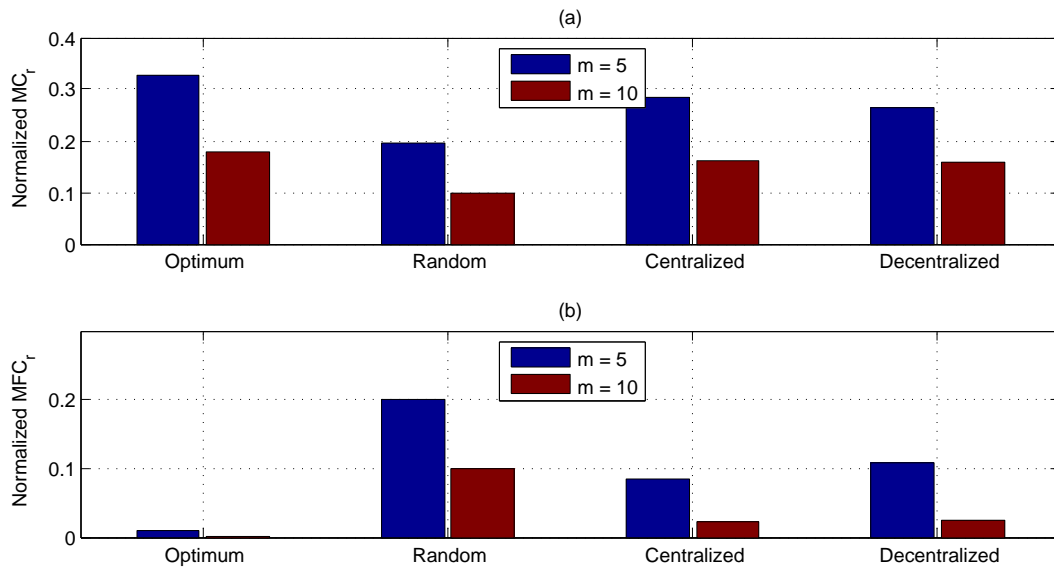

Figure 5.4: Performance Evaluation comparison between the proposed centralized and decentralized NS without SCA and random and optimum NS

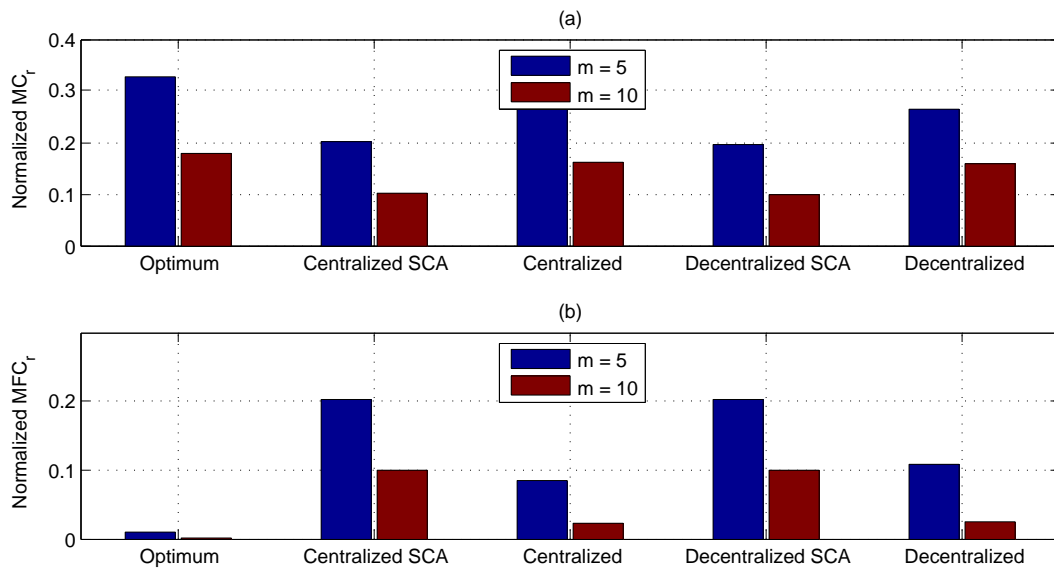

Figure 5.5: Performance comparison between centralized and decentralized NS with and without SCA

single-channel NS. Where these optimal NS assume that there is perfect and total information about the signal activity as well if each of the LDs is within range of the signal sources in each of the monitored channels.

A centralized and a decentralized NS algorithm were proposed, and their performance compared to the optimal NS, as well with the random NS, i.e. channel un-aware NS which has the same performance as a round-robin based scheme. The proposed schemes are able to work in the case where there is enough and the case where there is not yet enough information about the signal activity and the location of the LDs in regards to the signal source. In the case where there is not enough information the algorithms resort to the use of SCA, while when they acquire enough information the assignment of a LD is done preferentially to a channel that most likely the LD will experience as vacant. The use of this later strategy, as shown in the performance comparison, allows to reach a performance near the optimum NS.

The proposed centralized and decentralized NS algorithm can be combined in the CSS, so that in case the CRN node acting as the central node withdraws from the CRN, then the decentralized NS is activated and then CSS can proceed.

The future steps of this work should be to study the effect of mobility in the information needed by the proposed NS algorithms.

## References

- [1] Ramesh Johari and John N. Tsitsiklis. Efficiency of scalar-parameterized mechanisms. *OPERATIONS RESEARCH*, 57(4):823–839, 2009.
- [2] F. Kelly. Charging and rate control for elastic traffic. *European Transactions on Telecommunications*, 8:33–37, 1997.
- [3] N. Pratas, N. Marchetti, N. R. Prasad, A. Rodrigues, and R. Prasad. Decentralized cooperative spectrum sensing for ad-hoc disaster relief network clusters. In *IEEE 71st Vehicular Technology Conference (VTC 2010-Spring)*, pages 1–5, May 2010.
- [4] N. Pratas, N. Marchetti, N.R. Prasad, A. Rodrigues, and R. Prasad. Centralized cooperative spectrum sensing for ad-hoc disaster relief network clusters. In *IEEE International Conference on Communications (ICC 2010)*, pages 1–5, May 2010.

# 6

## Conclusions and Outlook

### 6.1 Conclusions

The rapid growth of services offered through wireless communication has led to an apparent shortage of the radio frequency spectrum. After several measurements campaigns the common conclusion is that this shortage is in most cases caused by the assignment of the spectrum in a static manner over large geographical regions over long time periods. To overcome this, a new paradigm which allows accessing the radio spectrum in an opportunistic manner has been put forward. This paradigm is called Cognitive Radio, and the foundation of this opportunistic spectrum access is the awareness of the state of the radio spectrum in the surroundings of the cognitive radio network, which is accomplished through Spectrum Sensing (SS).

The SS performance depends on the local channel conditions, such as the multipath, shadowing and the receiver uncertainty issues. The conjunction of these conditions can result in regimes where the signal strength is below the detection threshold of the sensor, resulting in missed detections. To overcome this limitation, there have been several proposals made in the research community towards the use of cooperation in SS. Since the signal strength varies with the sensor location, the worst fading conditions can be avoided if multiple

sensors in different spatial locations share their local sensing measurements, i.e. take advantage of the spatial diversity.

In this thesis the focus was on how to accomplish this cooperation. For that purpose a Cooperative Spectrum Sensing (CSS) mechanism was proposed, which consists of a distributed protocol that connects the elements of this mechanism, being those the SS, Local Decisions Data Fusion (LDDF), Knowledge Base Update (KBU) and Node Selection (NS). The CSS mechanism goal is to ensure that all the Cognitive Radio Network (CRN) nodes know which spectrum to sense and when to sense, how to share the results from the sensing and how to ensure that all CRN nodes have an updated and synchronized information about the state of the monitored spectrum.

A Process Calculus (PC), denoted as Bounded Broadcast Calculus (BBC), was introduced to reason about the computational properties of the proposed distributed protocol. The BBC uses broadcast communication over channels with bounded capacity to allow a more realistic modelling of the CSS. Three different network topologies were considered – centralized, decentralized and relay based topologies – and their associated CSS protocols. In each case it was straightforward to describe conditions for protocol correctness that ensure that the agents participating in the cooperative scheme will eventually reach a resolved state every time a SS round is initiated. A theorem on the correctness of the protocols was given and proved by standard inductive proof techniques. The work showed that the use of process calculi provide a promising approach for describing and reasoning about the computational properties wireless communication protocols.

In this thesis it was considered on how to combine the local decisions from each of the local detectors participating in the CSS. The approach taken to combine these local decisions follows a two level parallel distributed detection system, which consists of a number of Local Detectors (LDs) connected to a fusion center. It was assumed that each Local Detector (LD) reaches a local decision in each sensing session, of the hard decision type, i.e. the result of the decision is encoded in just one bit, which is then transmitted to the fusion center. At the fusion center its considered that the data fusion is performed over the received local decisions using a fusion rule of the counting rule type. This rule counts the number of LDs that decided that a signal is present in the sensed channel and then compares that number with a decision threshold. When the number of positive LDs is higher than the decision threshold then the global decision is that a signal is present, otherwise that is absent. The analysis of this data fusion method is given first by providing a theoretical formulation which motivates the use of the counting rules in detriment of other data fusion

methods. The behaviour of the counting rules is then observed when varying its implicit parameters, such as the local probability of detection, false alarm and the number of LDs in place.

To evaluate the performance of the counting rules based data fusion, two performance evaluation metrics  $\phi$  and  $\epsilon$  were introduced. The counting rules were then evaluated using these performance metrics, first in general without considering the underlying LD model, then when considering the LD model and finally when the signal duty cycle varies.

The case where the LDs are non-identical is considered, which then gives rise for the motivation of using an Adaptable Counting Rule (ACR) mechanism, which adapts the  $k$ -threshold based on the experienced conditions of the LDs using the feedback when the CRN tries to access the sensed channel. The proposed ACR mechanism is then further refined to be more adaptable, and depend less on a-priori set thresholds. To measure the potential resources that the CSS mechanism can identify, it was introduced the concept of Capacity and False Capacity in the spectrum sensing context, and then an evaluation of both capacities along the data fusion chain is given. The Capacity metric measures the effect of the exposed node problem, while the False Capacity metric measures the effect of the hidden node problem. In this evaluation it was considered the correlation between the LDs, the number of LDs participating in the data fusion and the effect of the signal duty cycle. This study gave insights on how the data fusion process can be improved, so to increase the amount of perceived available resources in the sensed channel. Based on these insights a Cluster based Adaptive Counting Rule is then proposed, on which the LDs that experience similar signal conditions are grouped in clusters and where the data fusion is done separately for each cluster. The proposed clustering algorithm uses the correlation between the local decisions of the LDs over time to select the cluster where each LD should go. It was observed, in the case where there is only one signal source, that the proposed algorithm was able to achieve the same level of performance in terms of Capacity and False Capacity when compared to the perfect clustering algorithm where full information about the conditions at each of the LDs was available at the fusion center. In the case of multiple signal sources a generalized clustering algorithm was proposed, but its evaluation was left for future work.

Finally, it was shown why a NS mechanism is required for a CSS to work properly in a multi-channel scenario. This was done by first extending the proposed Capacity and False Capacity metrics to account for the case where multiple channels are being monitored. These metrics quantify not only the performance of the proposed NS but also give a measure of the performance achievable when using the optimum multi-channel and single-channel NS. These optimal NS assume that there is complete information about the signal activity as well as information on if the LDs are within range of the signal sources in each of the monitored channels. Then a centralized and a decentralized NS mechanisms were proposed, and their performance compared to the optimal NS, as well with the random NS, i.e. channel un-aware NS which has the same performance as a round-robin based scheme. The proposed schemes are able to work in the case where there is enough information and the case where there is not yet enough information about the signal activity and the location of the LDs in regards to the signal source. In the case where there is not enough information the algorithms resort to the use of Single Channel Assignment (SCA), while when they acquire enough information the assignment of a LD is done preferentially to a channel that most likely the LD will experience as vacant. The use of this later strategy, as shown in the performance comparison, allows to reach a performance near the optimum NS. The proposed centralized and decentralized NS algorithm can be combined in the CSS, so that in case the CRN node acting as the central node withdraws from the CRN, then the decentralized NS is activated and then CSS can proceed.

In conclusion, in this thesis was proposed a CSS mechanism, where the focus was given in the properties and correctness of the distributed protocol that enables it, the way on how the data fusion is performed and finally on how the LDs should cooperate.

## **6.2 Outlook**

Possible directions of this work, can be on how to combine the proposed methodologies and algorithms to work together with knowledge databases, both to update them as well as using their information to improve the performance the proposed mechanism. Other future steps of this work should be to study the effect of mobility in the information needed by the proposed NS algorithms, as well as the effect of using a noisy reporting channel.

The proposed CSS mechanism should be integrated in an actual network, so that it could be possible to study if there is added value for the network

to be spectrum aware. An example could be an wifi network, where after the CSS mechanism is integrated, it could be measured if there was an increase on the performance of the network, both in terms of throughput as well as interference reduction in the surrounding wifi networks.





# A

## Appendix - Centralized Topology Induction Proof

The theorem for the Centralized Topology which states the correctness is given by the following:

**Theorem 3.** *Let  $S$  be:*

$$S \equiv (\nu\bar{c}\bar{c}) \left( \prod_{i \in I} cl \bowtie sl_i \right) \mid CN \mid \prod_{i \in I} SN_i \quad (\text{A.1})$$

if  $|I| = n$ .

*Then  $S$  satisfies the following:*

1.  $S \longrightarrow^* S'$  where  $S'$  is resolved
2. for any  $S'$  where  $S \longrightarrow^* S'$  and  $S'$  resolved.  $\exists S''$  such that  $S' \longrightarrow^+ S''$ ,  $S''$  is resolved.

*Proof.* The proof of the theorem is accomplished by induction hypothesis in the size of  $I$ .

## A.1 Base-Case

The purpose of the base case proof is to show that the network reaches after a sequence of reduction steps a certain step denoted as the resolved state, which if the network is properly constructed then according to Theorem 3 after a cycle of reduction steps that same resolved state will be reached, and therefore proof that the base case of the structure  $S$  reaches a resolved state and therefore is correct.

The definition of resolved state in the centralized topology is given by,

**Definition 7.**  $S$  is resolved if  $S \equiv S' | cl [\bar{c}\bar{c}\langle n_{CN}, NS(c)\rangle]$  for some  $n_{CN}$  and  $c$ .

The first step of the proof is to resolve the  $S$  structure when  $|I| = 1$ . The  $S$  structure in this case reduces as

$$S \equiv \underbrace{(\nu\bar{c}\bar{c})}_{S^I} (cl \bowtie sl) | CN | SN \quad (A.2)$$

When the network is instantiated, the Central Node,  $CN$ , needs to send the request to the Sensing Node,  $SN$ , regarding which channel should be sensed. This is assumed to be the network initial state.

And the sequence of reductions follows,

$$S^I | SN | CN \longrightarrow^* \underbrace{S^I | SN | CN | \bar{c}\bar{c}\langle n_{CN}, NS(c)\rangle}_{\text{Resolved State}} \quad (A.3)$$

In the following is shown the expanded version of the sequence of reductions. So first is shown the computation of the reduction sequences from the initial state until the resolved state.

$$S^I | SN | CN \equiv$$

$$S^I | SN | \left( \prod_{m \in M} Q_m | T \right) | \underbrace{(\nu n_{CN}) * \left( \prod_{m \in M} Q_m | T \right)}_{CN} | R \longrightarrow$$

$$S^I | SN \left( \prod_{m \in M} \underbrace{Q_m}_{\text{No SN reports available}} | T \right) | CN \equiv$$

$$\begin{aligned}
& S^I \mid SN \mid \left( \prod_{m \in M} \bar{h}\langle KBU(\square) \rangle \mid T \right) \mid CN \equiv \\
& S^I \mid SN \mid CN \mid \left( \prod_{m \in M} \bar{h}\langle \underbrace{KBU(\square)}_{kbu_m} \rangle \mid T \right) \equiv \\
& S^I \mid SN \mid CN \mid \left( \prod_{m \in M} \bar{h}\langle kbu_m \rangle \mid T_1 \mid T_2 \right) \equiv \\
& S^I \mid SN \mid CN \mid \left( \prod_{m \in M} \bar{h}\langle kbu_m \rangle \mid C_{KBU(\square)} \mid T_2 \right) \longrightarrow \\
& S^I \mid SN \mid CN \mid \bar{k}\langle kbu_1 :: kbu_M \rangle. \mid k(e). \bar{c}\bar{c}\langle n_{CN}, NS(e) \rangle \longrightarrow \\
& \underbrace{S^I \mid SN \mid CN \mid \bar{c}\bar{c}\langle n_{CN}, NS(kbu_1 :: kbu_M) \rangle}_{\text{Resolved State}}
\end{aligned}$$

And so the network reaches the resolved state and from there on the network is considered to be initialized. The purpose of this proof is to show that the network reaches the same resolved state after a given number of iterations, as stated in the Theorem 3.

$$\begin{aligned}
& S^I \mid SN \mid CN \mid \bar{c}\bar{c}\langle n_{CN}, \underbrace{NS(kbu_1 :: kbu_M)}_{ns} \rangle \equiv \\
& S^I \mid \underbrace{(\nu n_{SN}) * P \mid R}_{SN} \mid CN \mid \bar{c}\bar{c}\langle n_{CN}, ns \rangle \equiv \\
& S^I \mid P \mid \underbrace{(\nu n_{SN}) * P \mid R}_{SN} \mid CN \mid \bar{c}\bar{c}\langle n_{CN}, ns \rangle \equiv \\
& S^I \mid P \mid SN \mid CN \mid \bar{c}\bar{c}\langle n_{CN}, ns \rangle \equiv
\end{aligned}$$

$$S^I \mid \underbrace{P_1 \mid P_2 \mid P_3}_P \mid SN \mid CN \mid \bar{c}\bar{c}\langle n_{CN}, ns \rangle \equiv$$

$$S^I \mid cc(\lambda(x, y)(x, y)) \text{ if } x = n_{CN} \text{ then} \\ \bar{e}\langle y \rangle \mid P_2 \mid P_3 \mid SN \mid CN \mid \bar{c}\bar{c}\langle n_{CN}, ns \rangle \longrightarrow$$

$$S^I \mid \bar{e}\langle ns \rangle \mid P_2 \mid P_3 \mid SN \mid CN \equiv$$

$$S^I \mid \bar{e}\langle ns \rangle \mid e(a).\bar{f}\langle SS(a) \rangle \mid f(b).\bar{c}\bar{c}\langle n_{SN}, b \rangle \mid SN \mid CN \longrightarrow$$

$$S^I \mid \bar{f}\langle SS(ns) \rangle \mid f(b).\bar{c}\bar{c}\langle n_{SN}, b \rangle \mid SN \mid CN \longrightarrow$$

$$S^I \mid \bar{c}\bar{c}\langle n_{SN}, \underbrace{SS(ns)}_{x_1} \rangle \mid SN \mid CN \equiv$$

$$S^I \mid \bar{c}\bar{c}\langle n_{SN}, x_1 \rangle \mid SN \mid \underbrace{(\nu n_{CN}) * \left( \prod_{m \in M} Q_m \mid T \right)}_{CN} \mid R \longrightarrow$$

$$S^I \mid \bar{c}\bar{c}\langle n_{SN}, x_1 \rangle \mid SN \mid \left( \prod_{m \in M} Q_m \mid T \right) \mid CN \equiv$$

$$S^I \mid \bar{c}\bar{c}\langle n_{SN}, x_1 \rangle \mid SN \mid \left( \prod_{m \in M} Q_{m1} \mid Q_{m2} \mid Q_{m3} + Q_{m4} \right) \mid T \mid CN \longrightarrow$$

Since the Central Node (CN) receives the reports from the Sensing Node (SN) then the process  $Q_{m4}$  does not run.

$$S^I \mid \bar{c}\bar{c}\langle n_{SN}, x_1 \rangle \mid SN \mid \left( \prod_{m \in M} Q_{m1} \mid Q_{m2} \mid Q_{m3} \right) \mid T \mid CN \equiv$$

$$S^I \mid \bar{c}\bar{c}\langle n_{SN}, x_1 \rangle \mid SN \mid \left( \prod_{m \in M} C_m(\square) \mid Q_{m2} \mid Q_{m3} \right) \mid T \mid CN \longrightarrow$$

$$\begin{aligned}
& S^I \mid \bar{c}\langle n_{SN}, x_1 \rangle \mid SN \mid \\
& \left( \prod_{m \in M} cc(\lambda(x, y)(x, y)) \text{ if } x \neq n_{CN} \text{ then } C_m(y :: l) + \right. \\
& \quad \left. \bar{d}_m \langle l \rangle \mid Q_{m2} \mid Q_{m3} \right) \mid T \mid CN \longrightarrow \\
& S^I \mid SN \mid \left( \prod_{m \in M} \bar{d}_m \langle \underbrace{(x_1 :: x_k)}_{y_m} \rangle \mid Q_{m2} \mid Q_{m3} \right) \mid T \mid CN \equiv \\
& S^I \mid SN \mid \left( \prod_{m \in M} \bar{d}_m \langle y_m \rangle \mid d_m(e) \cdot \bar{g}_m \langle LDDF(e) \rangle \mid Q_{m3} \right) \mid T \mid CN \longrightarrow \\
& S^I \mid SN \mid \left( \prod_{m \in M} \bar{g}_m \langle LDDF(y_m) \rangle \mid g_m(i) \cdot \bar{h} \langle KBU(i) \rangle \right) \mid T \mid CN \equiv \\
& S^I \mid SN \mid \left( \prod_{m \in M} \bar{h} \langle \underbrace{KBU(LDDF(y_m))}_{kb_{um}} \rangle \right) \mid T \mid CN \equiv \\
& S^I \mid SN \mid \left( \prod_{m \in M} \bar{h} \langle kb_{um} \rangle \right) \mid T \mid CN \equiv \\
& S^I \mid SN \mid \left( \prod_{m \in M} \bar{h} \langle kb_{um} \rangle \right) \mid T_1 \mid T_2 \mid CN \equiv \\
& S^I \mid SN \mid \left( \prod_{m \in M} \bar{h} \langle kb_{um} \rangle \right) \mid C_{KBU}(\square) \mid T_2 \mid CN \longrightarrow \\
& S^I \mid SN \mid \bar{k} \langle kb_{u_1} :: kb_{u_M} \rangle \mid T_2 \mid CN \longrightarrow \\
& S^I \mid SN \mid \bar{k} \langle kb_{u_1} :: kb_{u_M} \rangle \mid k(e) \cdot \bar{c}\langle n_{CN}, NS(e) \rangle \mid CN \longrightarrow \\
& \underbrace{S^I \mid SN \mid \bar{c}\langle n_{CN}, NS(kb_{u_1} :: kb_{u_M}) \rangle \mid CN}_{\text{Resolved State}}
\end{aligned}$$

As stated, the resolved state is achieved and therefore it is shown that after the certain number of iterations the network  $S$  resolves to  $S'$

## A.2 $N + 1$ Case

Following the induction hypothesis it is assumed that when  $|I| = N$ ,  $S$  reaches the resolved state, and so to complete the proof it is shown what happens when an extra  $SN$  is added to the network, i.e. the number of nodes in the network is  $|I| = N + 1$ .

$$S \equiv \underbrace{(\nu \bar{c} \bar{c}) \left( \prod_{i \in I} cl \bowtie sl_i \right)}_{S^I} | CN | \prod_{i \in I} SN_i$$

The first step is to initialize the network until it reaches the resolved state, and although that it follows the same steps as in the base case, the sequence of reduction steps until the resolved state is reached are shown here.

$$\begin{aligned} S^I | SN_1 | SN_2 | \dots | SN_{N-1} | SN_N | SN_{N+1} | CN &\longrightarrow \\ \underbrace{S^I | SN_1 | SN_2 | \dots | SN_{N-1} | SN_N | SN_{N+1}}_{S^{II}} | \left( \prod_{m \in M} Q_m | T \right) &| \\ | (\nu n_{CN}) * \underbrace{\left( \prod_{m \in M} Q_m | T \right)}_{CN} &| R \equiv \\ S^{II} | \left( \prod_{m \in M} \underbrace{Q_{4m}}_{\text{No SN reports available}} | T \right) &| CN \equiv \\ S^{II} | \left( \prod_{m \in M} \bar{h} \langle \underbrace{KBU(\square)}_{kbu_m} \rangle | T \right) &| CN \equiv \\ S^{II} | \left( \prod_{m \in M} \bar{h} \langle kbu_m \rangle | T_1 | T_2 \right) &| CN \equiv \\ S^{II} | \left( \prod_{m \in M} \bar{h} \langle kbu_m \rangle | C_{KBU(\square)} | T_2 \right) &| CN \longrightarrow \end{aligned}$$

$$S^{II} | \bar{k}\langle kbu_1 :: kbu_M \rangle. | k(e).\bar{cc}\langle n_{CN}, NS(e) \rangle | CN \longrightarrow$$

$$\underbrace{S^{II} | \bar{cc}\langle n_{CN}, NS(kbu_1 :: kbu_M) \rangle | CN}_{\text{Resolved State}}$$

The network  $S$  reaches the resolved state and from here on the network is assumed to be initialized. In this part of the proof, it is shown that even when there are  $N + 1$  Sensing Nodes (SNs) in the network, the network will reach the resolved state after a finite number of reduction steps.

$$S^{II} | \bar{cc}\langle n_{CN}, \underbrace{NS(kbu_1 :: kbu_M)}_{ns} \rangle | CN \equiv$$

$$S' | SN_1 | SN_2 | \dots | SN_{N-1} | SN_N | SN_{N+1} | \bar{cc}\langle n_{CN}, ns \rangle | CN \longrightarrow$$

$S^{III}$  is introduced to ease the proof, since the reduction sequences that happen in  $SN_1$  are the same for the other  $N$  SNs, as shown in A.1.

$$SN_1 | \underbrace{S' | SN_2 | \dots | SN_{N-1} | SN_N | SN_{N+1} | CN}_{S^{III}} | \bar{cc}\langle n_{CN}, ns \rangle \equiv$$

$$S^{III} | \underbrace{((\nu n_{SN_1}) * P | R)}_{SN_1} | \bar{cc}\langle n_{CN}, ns \rangle \longrightarrow$$

$$S^{III} | P_1 | P_2 | P_3 | SN_1 | \bar{cc}\langle n_{CN}, ns \rangle \equiv$$

$$S^{III} | cc(\lambda(x, y)(x, y)) \text{ if } x = n_{CN} \text{ then } \bar{e}\langle y \rangle \\ | P_2 | P_3 | SN_1 | \bar{cc}\langle n_{CN}, ns \rangle \longrightarrow$$

$$S^{III} | \bar{e}\langle ns \rangle | P_2 | P_3 | SN_1 \equiv$$

$$S^{III} | \bar{e}\langle ns \rangle | e(a).\bar{f}\langle SS(a) \rangle | f(b).\bar{cc}\langle n_{SN_1}, b \rangle | SN_1 \longrightarrow$$

$$S^{III} | \bar{f}\langle SS(ns) \rangle | f(b).\bar{cc}\langle n_{SN_1}, b \rangle | SN_1 \equiv$$

$$S^{III} | \bar{cc}\langle n_{SN_1}, \underbrace{SS(ns)}_{x_1} \rangle | SN_1 \equiv$$

$$S^I | (\bar{cc}\langle n_{SN_1}, x_1 \rangle | SN_1) | (\bar{cc}\langle n_{SN_2}, x_2 \rangle | SN_2) | \dots | \\ (\bar{cc}\langle n_{SN_N}, x_N \rangle | SN_N) | (\bar{cc}\langle n_{SN_{N+1}}, x_{N+1} \rangle | SN_{N+1}) | CN \equiv$$

Now in this reduction step depending on when whether the  $N + 1$  is bigger or smaller than  $b(cc, cl)$ , messages can be dropped or not.



### A.2.1 $N + 1 < b(cc, cl)$

Here is considered the case where the number of SNs is lower than  $b(cc, cl)$ , the capacity of the control channel at the  $cl$  location.

$$\underbrace{S^I | (\overline{cc}\langle n_{SN_1}, x_1 \rangle | SN_1) | \dots | (\overline{cc}\langle n_{SN_{N+1}}, x_{N+1} \rangle | SN_{N+1}) | CN}_{S^{II}} \equiv$$

$$S^{II} | \underbrace{(\nu n_{CN}) * \left( \prod_{m \in M} Q_m | T \right)}_{CN} | R \longrightarrow$$

$$S^{II} | \left( \prod_{m \in M} Q_m | T \right) | CN \equiv$$

$$S^{II} | \left( \prod_{m \in M} Q_{m1} | Q_{m2} | Q_{m3} + Q_{m4} \right) | T | CN \longrightarrow$$

Since the CN receives the reports from the SNs then the process  $Q_{m4}$  does not run.

$$S^{II} | \left( \prod_{m \in M} Q_{m1} | Q_{m2} | Q_{m3} \right) | T | CN \equiv$$

$$S^{II} | \left( \prod_{m \in M} C_m(\square) | Q_{m2} | Q_{m3} \right) | T | CN \longrightarrow$$

$$S^{II} | \left( \prod_{m \in M} cc(\lambda(x, y)(x, y)) \text{ if } x \neq n_{CN} \text{ then } C_m(y :: l) + \overline{d}_m\langle l \rangle | \right. \\ \left. Q_{m2} | Q_{m3} \right) | T | CN \longrightarrow$$

$$S^{II} | \left( \prod_{m \in M} \overline{d}_m\langle (x_1 :: x_k) \rangle | Q_{2m} | Q_{3m} \right) | T | CN \equiv$$

$$S^{II} \mid \left( \prod_{m \in M} \bar{d}_m \langle (x_1 :: x_k) \rangle \mid d_m(e) \cdot \bar{g}_m \langle LDDF(e) \rangle \mid Q_{3m} \right) \mid T \mid CN \longrightarrow$$

$$S^{II} \mid \left( \prod_{m \in M} \bar{g}_m \langle LDDF(x_1 :: x_k) \rangle \mid g_m(i) \cdot \bar{h} \langle KBU(i) \rangle \right) \mid T \mid CN \longrightarrow$$

$$S^{II} \mid \left( \prod_{m \in M} \bar{h} \langle KBU(LDDF(x_1 :: x_k)) \rangle \right) \mid T \mid CN \equiv$$

$$S^{II} \mid \left( \prod_{m \in M} \bar{h} \langle \underbrace{KBU(LDDF(x_1 :: x_k))}_{kbu_m} \rangle \right) \mid T_1 \mid T_2 \mid CN \equiv$$

$$S^{II} \mid \left( \prod_{m \in M} \bar{h} \langle kbu_m \rangle \right) \mid T_1 \mid T_2 \mid CN \equiv$$

$$S^{II} \mid \left( \prod_{m \in M} \bar{h} \langle kbu_m \rangle \right) \mid C_{KBU}(\square) \mid T_2 \mid CN \longrightarrow$$

$$S^{II} \mid \bar{k} \langle kbu_1 :: kbu_M \rangle \mid T_2 \mid CN \equiv$$

$$S^{II} \mid \bar{k} \langle kbu_1 :: kbu_M \rangle \mid k(e) \cdot \bar{cc} \langle n_{CN}, NS(e) \rangle \mid CN \longrightarrow$$

$$\underbrace{S^{II} \mid \bar{cc} \langle n_{CN}, NS(kbu_1 :: kbu_M) \rangle}_{\text{Resolved State}} \mid CN \longrightarrow$$

The network  $S$  when  $|I| = N + 1$  and  $|I| < b(cc, cl)$ , reaches the resolved state, as stated in Theorem 3.

**A.2.2**  $N + 1 > b(cc, cl)$

In this case the SNs will start reporting back to the CN through the  $cc$ , which has limited capacity given by  $b(cc, cl)$ , and therefore some of the SNs messages will be dropped following the  $R - DROP$  reduction rule in Table 3.5.

$$S^I \mid \underbrace{(\overline{cc}\langle n_{SN_1}, x_1 \rangle \mid SN_1) \mid \dots \mid (\overline{cc}\langle n_{SN_b}, x_b \rangle \mid SN_b)}_{Keep} \mid \underbrace{(\overline{cc}\langle n_{SN_{b+1}}, x_{b+1} \rangle \mid SN_{b+1}) \mid \dots \mid (\overline{cc}\langle n_{SN_{N+1}}, x_{N+1} \rangle \mid SN_{N+1})}_{Drop} \mid CN \longrightarrow$$

$$S^I \mid \underbrace{(\overline{cc}\langle n_{SN_1}, x_1 \rangle \mid SN_1) \mid \dots \mid (\overline{cc}\langle n_{SN_b}, x_b \rangle \mid SN_b)}_{S^{IV}} \mid \underbrace{SN_{b+1} \mid \dots \mid SN_N \mid SN_{N+1}}_{S^V} \mid CN \longrightarrow$$

$$\underbrace{S^I \mid S^{IV} \mid S^V}_{S^{II}} \mid CN \equiv$$

$$S^{II} \mid * \left( \underbrace{\prod_{m \in M} Q_m \mid T}_{CN} \right) \mid R \longrightarrow$$

$$S^{II} \mid \left( \prod_{m \in M} Q_m \mid T \right) \mid CN \equiv$$

$$S^{II} \mid \left( \prod_{m \in M} Q_{m1} \mid Q_{m2} \mid Q_{m3} + Q_{m4} \right) \mid T \mid CN \longrightarrow$$

Since the CN receives the reports from the SNs then the process  $Q_{m4}$  does not run.

$$S^{II} \mid \left( \prod_{m \in M} Q_{m1} \mid Q_{m2} \mid Q_{m3} \right) \mid T \mid CN \equiv$$

$$\begin{aligned}
& S^{II} \mid \left( \prod_{m \in M} C_m(\emptyset) \mid Q_{m2} \mid Q_{m3} \right) \mid T \mid CN \longrightarrow \\
& S^{II} \mid \left( \prod_{m \in M} cc(\lambda(x, y)(x, y)) \text{ if } x \neq n_{CN} \text{ then } C_m(y :: l) + \overline{d_m}\langle l \rangle \mid \right. \\
& \qquad \qquad \qquad \left. Q_{2m} \mid Q_{3m} \right) \mid T \mid CN \longrightarrow \\
& S^{II} \mid \left( \prod_{m \in M} \overline{d_m}\langle (x_1 :: x_k) \rangle \mid Q_{2m} \mid Q_{3m} \right) \mid T \mid CN \equiv \\
& S^{II} \mid \left( \prod_{m \in M} \overline{d_m}\langle (x_1 :: x_k) \rangle \mid d_m(e).\overline{g_m}\langle LDDF(e) \rangle \mid Q_{3m} \right) \mid T \mid CN \longrightarrow \\
& S^{II} \mid \left( \prod_{m \in M} \overline{g_m}\langle LDDF(x_1 :: x_k) \rangle \mid g_m(i).\overline{h}\langle KBU(i) \rangle \right) \mid T \mid CN \longrightarrow \\
& S^{II} \mid \left( \prod_{m \in M} \overline{h}\langle \underbrace{KBU(LDDF(x_1 :: x_k))}_{kbu_m} \rangle \right) \mid T \mid CN \equiv \\
& S^{II} \mid \left( \prod_{m \in M} \overline{h}\langle kbu_m \rangle \right) \mid T_1 \mid T_2 \mid CN \equiv \\
& S^{II} \mid \left( \prod_{m \in M} \overline{h}\langle kbu_m \rangle \right) \mid C_{KBU}(\emptyset) \mid T_2 \mid CN \equiv \\
& S^{II} \mid \left( \prod_{m \in M} \overline{h}\langle kbu_m \rangle \right) \mid h(b).C_{KBU}(b :: l) + \overline{k}\langle l \rangle \mid T_2 \mid CN \equiv \\
& S^{II} \mid \overline{k}\langle kbu_1 :: kbu_M \rangle \mid T_2 \mid CN \equiv \\
& S^{II} \mid \overline{k}\langle kbu_1 :: kbu_M \rangle \mid k(e).\overline{cc}\langle n_{CN}, NS(e) \rangle \mid CN \longrightarrow \\
& \underbrace{S^{II} \mid \overline{cc}\langle n_{CN}, NS(kbu_1 :: kbu_M) \rangle \mid CN \longrightarrow}_{\text{Resolved State}}
\end{aligned}$$

So when  $|I| = N + 1$  and  $|I| > b(cc, cl)$  the network  $S$  still reaches the resolved state, as stated in Theorem 3.  $\square$



# B

## Appendix - Decentralized Topology Induction Proof

The theorem for the Decentralized Topology which states the correctness is given by the following:

**Theorem 4.** *Let  $S$  be:*

$$S \equiv (\nu\bar{c}\bar{c}) \left( \prod_{i,j \in I, i \neq j} sl_i \bowtie sl_j \right) \mid \prod_{i \in I} SN_i \quad (\text{B.1})$$

if  $|I| = n$ .

*Then  $S$  satisfies the following:*

1.  $S \longrightarrow^* S'$  where  $S'$  is resolved
2. for any  $S'$  where  $S \longrightarrow^* S'$  and  $S'$  resolved.  $\exists S''$  such that  $S' \longrightarrow^+ S''$ ,  $S''$  is resolved.

*Proof.* The proof of the theorem is accomplished by induction hypothesis in the size of  $I$ .

## B.1 Base-Case

### B.1.1 $|I| = 1$

Again, the procedure is to perform induction in  $n = |I|$ . The definition of resolved state in the decentralized topology is given by,

**Definition 8.**  $S$  is resolved if  $S \equiv S' \mid \prod_{i \in I} sl_i [\overline{w_i} \langle NS(c) \rangle]$  for some  $c$ .

The first step is to resolve  $S$  when  $|I| = 1$ , where there is only one node and therefore there is no network. In this case the node should still work, i.e. should still resolve.

The  $S$  structure in this case is defined as,

$$S \equiv \underbrace{(\nu \vec{c} \vec{c})}_{S^I} (sl_1) \mid SN_1$$

When the network is instantiated, none of the SNs knows which channel to sense. Therefore there is an initialization process to be done, which we will consider next.

So first we compute the steps from the initial state until the resolved state.

$$S^I \mid SN_1 \equiv$$

$$S^I \mid \nu_{n_{SN}} * \left( \prod_{m \in M} Q_m \mid T \mid P \right) \mid R_{SN} \longrightarrow$$

$$S^I \mid \left( \prod_{m \in M} Q_m \mid T \mid P \right) \mid \underbrace{\nu_{n_{SN}} * \left( \prod_{m \in M} Q_m \mid T \mid P \right) \mid R_{SN}}_{SN_1} \equiv$$

$$S^I \mid \left( \prod_{m \in M} Q_m \right) \mid T \mid P \mid \underbrace{\nu_{n_{SN}} * \left( \prod_{m \in M} Q_m \mid T \mid P \right) \mid R_{SN}}_{SN_1} \equiv$$

$$S^I \mid \left( \prod_{m \in M} Q_m \right) \mid T \mid P \mid SN_1 \equiv$$

$$S^I \mid \left( \prod_{m \in M} Q_{m1} \mid Q_{m2} \mid Q_{m3} + Q_{m4} \right) \mid T \mid P \mid SN_1 \longrightarrow$$

$$S^I \mid \left( \prod_{m \in M} Q_{m4} \right) \mid T \mid P \mid SN_1 \equiv$$

$$S^I \mid \left( \prod_{m \in M} \bar{h}\langle KBU(\square) \rangle \right) \mid T \mid P \mid SN_1 \equiv$$

$$S^I \mid \left( \prod_{m \in M} \bar{h}\langle KBU(\square) \rangle \right) \mid T_1 \mid T_2 \mid P \mid SN_1 \equiv$$

$$S^I \mid \left( \prod_{m \in M} \bar{h}\langle \underbrace{KBU(\square)}_{kbu_m} \rangle \right) \mid T_1 \mid T_2 \mid P \mid SN_1 \equiv$$

$$S^I \mid \left( \prod_{m \in M} \bar{h}\langle kbu_m \rangle \right) \mid (C_{KBU}(\square)) \mid T_2 \mid P \mid SN_1 \equiv$$

$$S^I \mid \left( \prod_{m \in M} \bar{h}\langle kbu_m \rangle \right) \mid h(b).C_{KBU}(b, y_1 :: y_M) \\ + \bar{k}\langle y_1 :: y_M \rangle \mid T_2 \mid P \mid SN_1 \longrightarrow^+$$

$$S^I \mid \bar{k}\langle kbu_1 :: kbu_M \rangle \mid k(e).\bar{w}\langle NS(e) \rangle \mid P \mid SN_1 \longrightarrow$$

$$S^I \mid \underbrace{\bar{w}\langle \underbrace{NS(kbu_1 :: kbu_M)}_{ss_1} \rangle}_{ResolvedState} \mid P \mid SN_1 \equiv$$

$$S^I \mid \bar{w}\langle ss_1 \rangle \mid P_1 \mid P_2 \mid P_3 \mid SN_1 \equiv$$

$$S^I \mid \bar{w}\langle ss_1 \rangle \mid w(a).\bar{e}\langle a \rangle \mid P_2 \mid P_3 \mid SN_1 \longrightarrow$$



$$S^I \mid \bar{e}\langle ss_1 \rangle \mid e(a).\bar{f}\langle SS(a) \rangle \mid P_3 \mid SN_1 \longrightarrow$$

$$S^I \mid \bar{f}\langle SS(ss_1) \rangle \mid P_3 \mid SN_1 \longrightarrow$$

$$S^I \mid \bar{f}\langle SS(ss_1) \rangle \mid f(b).\bar{v}\langle b \rangle.\bar{cc}\langle (n_{SN}, b) \rangle \mid SN_1 \longrightarrow$$

$$S^I \mid \bar{v}\langle SS(ss_1) \rangle.\bar{cc}\langle (n_{SN}, SS(ss_1)) \rangle \mid SN_1 \equiv$$

$$S^I \mid \bar{v}\langle SS(ss_1) \rangle.\bar{cc}\langle (n_{SN}, SS(ss_1)) \rangle \mid$$

$$\underbrace{\nu_{n_{SN}} * \left( \prod_{m \in M} Q_m \mid T \mid P \right)}_{SN_1} \mid R_{SN} \longrightarrow$$

$$S^I \mid \bar{v}\langle SS(ss_1) \rangle.\bar{cc}\langle (n_{SN}, SS(ss_1)) \rangle \mid \left( \prod_{m \in M} Q_m \right) \mid T \mid P \mid SN_1 \equiv$$

$$S^I \mid \bar{v}\langle SS(ss_1) \rangle.\bar{cc}\langle (n_{SN}, SS(ss_1)) \rangle \mid$$

$$\left( \prod_{m \in M} Q_{m1} \mid Q_{m2} \mid Q_{m3} + Q_{m4} \right) \mid T \mid P \mid SN_1 \longrightarrow$$

$$S^I \mid \bar{v}\langle SS(ss_1) \rangle.\bar{cc}\langle (n_{SN}, SS(ss_1)) \rangle \mid$$

$$\left( \prod_{m \in M} Q_{m1} \mid Q_{m2} \mid Q_{m3} \right) \mid T \mid P \mid SN_1 \equiv$$

$$S^I \mid \bar{v}\langle SS(ss_1) \rangle.\bar{cc}\langle (n_{SN}, SS(ss_1)) \rangle \mid$$

$$\left( \prod_{m \in M} v(b).C_m(b, x_1 :: x_k) + cc(\lambda(x, y)(x, y)) \text{ if } x = n_{SN} \text{ then} \right.$$

$$\left. C_m(y, x_1 :: x_k) + \bar{d}_m\langle (x_1 :: x_k) \rangle \mid Q_{m2} \mid Q_{m3} \mid T \mid P \mid SN_1 \longrightarrow$$

$$S^I \mid \bar{v}\langle SS(ss_1) \rangle.\bar{cc}\langle (n_{SN}, SS(ss_1)) \rangle \mid$$

$$\left( \prod_{m \in M} cc(\lambda(x, y)(x, y)) \text{ if } x = n_{SN} \text{ then} \right.$$

$$\left. C_m(y, x_1 :: x_k) + \bar{d}_m\langle (x_1 :: x_k) \rangle \mid Q_{m2} \mid Q_{m3} \mid T \mid P \mid SN_1 \longrightarrow$$

$$\begin{aligned}
& S^I \mid \overline{cc}\langle(n_{SN}, SS(ss_1))\rangle \mid \left( \prod_{m \in M} cc(\lambda(x, y)(x, y)) \text{ if } x = n_{SN} \text{ then} \right. \\
& \quad \left. C_m(y, x_1 :: x_k) + \overline{d_m}\langle(x_1 :: x_k)\rangle \mid Q_{m2} \mid Q_{m3} \mid T \mid P \mid SN_1 \longrightarrow \right. \\
& S^I \mid \left( \prod_{m \in M} \overline{d_m}\langle(ss_1 :: ss_k)\rangle \mid Q_{m2} \mid Q_{m3} \mid T \mid P \mid SN_1 \equiv \right. \\
& S^I \mid \left( \prod_{m \in M} \overline{d_m}\langle ss_1 :: ss_k \rangle \mid d(e).\overline{g}\langle LDDF(e)\rangle \mid Q_{m3} \mid T \mid P \mid SN_1 \longrightarrow^+ \right. \\
& S^I \mid \left( \prod_{m \in M} \overline{d_m}\langle ss_1 :: ss_k \rangle \mid d_m(e).\overline{g_m}\langle LDDF(e)\rangle \mid Q_{m3} \mid \right. \\
& \quad \left. T \mid P \mid SN_1 \longrightarrow \right. \\
& S^I \mid \left( \prod_{m \in M} d_m(e).\overline{g_m}\langle LDDF(ss_1 :: ss_k)\rangle \mid Q_{m3} \mid \right. \\
& \quad \left. T \mid P \mid SN_1 \equiv \right. \\
& S^I \mid \left( \prod_{m \in M} d_m(e).\overline{g_m}\langle LDDF(ss_1 :: ss_k)\rangle \mid g(i).\overline{h}\langle KBU(i)\rangle \mid \right. \\
& \quad \left. T \mid P \mid SN_1 \longrightarrow \right. \\
& S^I \mid \prod_{m \in M} \overline{h}\langle \underbrace{KBU(LDDF(ss_1 :: ss_k))}_{kbu_m} \rangle \mid T \mid P \mid SN_1 \equiv \\
& S^I \mid \prod_{m \in M} \overline{h}\langle kb u_m \rangle \mid T_1 \mid T_2 \mid P \mid SN_1 \equiv \\
& S^I \mid \prod_{m \in M} \overline{h}\langle kb u_m \rangle \mid (C_{KBU}(\square)) \mid T_2 \mid P \mid SN_1 \equiv \\
& S^I \mid \prod_{m \in M} \overline{h}\langle kb u_m \rangle \mid h(b).C_{KBU}(b, y_1 :: y_M) \\
& \quad + \overline{k}\langle y_1 :: y_M \rangle \mid T_2 \mid P \mid SN_1 \longrightarrow^+ \\
& S^I \mid \overline{k}\langle kb u_1 :: kb u_M \rangle \mid T_2 \mid P \mid SN_1 \equiv \\
& S^I \mid \overline{k}\langle kb u_1 :: kb u_M \rangle \mid k(e).\overline{w}\langle NS(e)\rangle \mid P \mid SN_1 \longrightarrow \\
& \underbrace{S^I \mid \overline{w}\langle NS(kb u_1 :: kb u_M)\rangle}_{ResolvedState} \mid P \mid SN_1
\end{aligned}$$

### B.1.2 $|I| = 2$

The second step is to show that  $S$  resolves when  $|I| = 2$ , where there are two nodes and therefore a network can be formed.

The  $S$  structure in this case reduces as

$$S \equiv \underbrace{(\nu c \bar{c}) (sl_1 \bowtie sl_2)}_{S^I} | SN_1 | SN_2 \quad (\text{B.2})$$

And the sequence of reductions follows,

$$S^I | SN_1 | SN_2 \longrightarrow^* \underbrace{S^{II} | \bar{w}_1 \langle NS(c) \rangle | P^1 | \bar{w}_2 \langle NS(c) \rangle | P^2}_{ResolvedState} \quad (\text{B.3})$$

In the following is shown the expanded version of the sequence of reductions. When the network is instantiated, none of the SNs knows which channel to sense. Therefore there is an initialization process to be done. So first is shown the computation of the reduction sequences from the initial state until the resolved state.

$$\begin{aligned}
 S^I | SN_1 | SN_2 &\equiv \\
 S^I | \underbrace{\nu_{n_{SN_1}} * \left( \prod_{m \in M} Q_m^1 | T^1 | P^1 \right)}_{SN_1} | R_{SN}^1 | \\
 \underbrace{\nu_{n_{SN_2}} * \left( \prod_{m \in M} Q_m^2 | T^2 | P^2 \right)}_{SN_2} | R_{SN}^2 &\longrightarrow \\
 S^I | \left( \prod_{m \in M} Q_m^1 \right) | T^1 | P^1 | SN_1 | \left( \prod_{m \in M} Q_m^2 \right) | T^2 | P^2 | SN_2 &\equiv \\
 \underbrace{S^I | SN_1 | SN_2}_{S^{II}} | \left( \prod_{m \in M} Q_m^1 \right) | T^1 | P^1 | \left( \prod_{m \in M} Q_m^2 \right) | T^2 | P^2 &\equiv
 \end{aligned}$$

$$\begin{aligned}
& S^{II} \mid \left( \prod_{m \in M} Q_{m1}^1 \mid Q_{m2}^1 \mid Q_{m3}^1 + Q_{m4}^1 \right) \mid T^1 \mid P^1 \mid \\
& \left( \prod_{m \in M} Q_{m1}^2 \mid Q_{m2}^2 \mid Q_{m3}^2 + Q_{m4}^2 \right) \mid T^2 \mid P^2 \longrightarrow \\
& S^{II} \mid \left( \prod_{m \in M} Q_{m4}^1 \right) \mid T^1 \mid P^1 \mid \left( \prod_{m \in M} Q_{m4}^2 \right) \mid T^2 \mid P^2 \longrightarrow \\
& S^{II} \mid \left( \prod_{m \in M} \overline{h^1} \langle KBU(\square) \rangle \right) \mid T^1 \mid P^1 \mid \left( \prod_{m \in M} \overline{h^2} \langle CE(\langle \rangle) \rangle \right) \mid T^2 \mid P^2 \equiv \\
& S^{II} \mid \left( \prod_{m \in M} \overline{h^1} \langle \underbrace{KBU(\square)}_{kbu_m^1} \rangle \right) \mid T_1^1 \mid T_2^1 \mid P^1 \mid \\
& \left( \prod_{m \in M} \overline{h^2} \langle \underbrace{KBU(\langle \rangle)}_{kbu_m^2} \rangle \right) \mid T_1^2 \mid T_2^2 \mid P^2 \equiv \\
& S^{II} \mid \left( \prod_{m \in M} \overline{h^1} \langle kb u_m^1 \rangle \right) \mid T_1^1 \mid T_2^1 \mid P^1 \mid \left( \prod_{m \in M} \overline{h^2} \langle kb u_m^2 \rangle \right) \mid T_1^2 \mid T_2^2 \mid P^2 \equiv \\
& S^{II} \mid \left( \prod_{m \in M} \overline{h^1} \langle kb u_m^1 \rangle \right) \mid C_{KBU}^1(\square) \mid T_2^1 \mid P^1 \mid \\
& \left( \prod_{m \in M} \overline{h^2} \langle kb u_m^2 \rangle \right) \mid C_{KBU}^2(\square) \mid T_2^2 \mid P^2 \equiv \\
& S^{II} \mid \left( \prod_{m \in M} \overline{h^1} \langle kb u_m^1 \rangle \right) \mid h^1(b).C_{KBU}^1(b, y_1 :: y_M) \\
& \quad \quad \quad + \overline{k^1} \langle y_1 :: y_M \rangle \mid T_2^1 \mid P^1 \mid \\
& \left( \prod_{m \in M} \overline{h^2} \langle kb u_m^2 \rangle \right) \mid h^2(b).C_{KBU}^2(b, y_1 :: y_M) \\
& \quad \quad \quad + \overline{k^2} \langle y_1 :: y_M \rangle \mid T_2^2 \mid P^2 \longrightarrow^+
\end{aligned}$$

$$S^{II} \mid \overline{k^1} \langle kb u_1^1 :: kb u_M^1 \rangle \mid T_2^1 \mid P^1 \mid \overline{k^2} \langle kb u_1^2 :: kb u_M^2 \rangle \mid T_2^2 \mid P^2 \equiv$$

$$\begin{aligned} & S^{II} \mid \overline{k^1} \langle kb u_1^1 :: kb u_M^1 \rangle \mid k^1(e). \overline{w^1} \langle NS(e) \rangle \mid P^1 \\ & \mid \overline{k^2} \langle kb u_1^2 :: kb u_M^2 \rangle \mid k^2(e). \overline{w^2} \langle NS(e) \rangle \mid P^2 \longrightarrow^+ \end{aligned}$$

$$\underbrace{S^{II} \mid \overline{w^1} \langle NS(kb u_1^1 :: kb u_M^1) \rangle \mid P^1 \mid \overline{w^2} \langle NS(kb u_1^2 :: kb u_M^2) \rangle \mid P^2}_{ResolvedState} \longrightarrow^+$$

The second item of the theorem states that when the network achieves the resolved state, it can achieve it again after a number of reduction steps, as follows,

$$\underbrace{S^{II} \mid \overline{w^1} \langle NS(c) \rangle \mid P^1 \mid \overline{w^2} \langle NS(c) \rangle \mid P^2}_{ResolvedState} \longrightarrow^+ \quad (B.4)$$

$$\underbrace{S^{II} \mid \overline{w^1} \langle NS(c) \rangle \mid P^1 \mid \overline{w^2} \langle NS(c) \rangle \mid P^2}_{ResolvedState} \quad (B.5)$$

This can be proved by the following sequence of reductions,

$$S^{II} \mid \overline{w^1} \underbrace{\langle NS(kb u_1^1 :: kb u_M^1) \rangle}_{ns^1} \mid P^1 \mid \overline{w^2} \underbrace{\langle NS(kb u_1^2 :: kb u_M^2) \rangle}_{ns^2} \mid P^2 \equiv$$

$$S^{II} \mid \overline{w^1} \langle ns^1 \rangle \mid P^1 \mid \overline{w^2} \langle ns^2 \rangle \mid P^2 \equiv$$

$$S^{II} \mid \overline{w^1} \langle ns^1 \rangle \mid P_1^1 \mid P_2^1 \mid P_3^1 \mid \overline{w^2} \langle ns^2 \rangle \mid P_1^2 \mid P_2^2 \mid P_3^2 \equiv$$

$$\begin{aligned} S^{II} \mid \overline{w^1} \langle ns^1 \rangle \mid w^1(a). \overline{e^1} \langle a \rangle \mid P_2^1 \mid P_3^1 \mid \overline{w^2} \langle ns^2 \rangle \mid \\ w^2(a). \overline{e^2} \langle a \rangle \mid P_2^2 \mid P_3^2 \longrightarrow \end{aligned}$$

$$S^{II} \mid \overline{e^1} \langle ns^1 \rangle \mid P_2^1 \mid P_3^1 \mid \overline{e^2} \langle ns^2 \rangle \mid P_2^2 \mid P_3^2 \equiv$$

$$S^{II} \mid \overline{e^1} \langle ns^1 \rangle \mid e^1(a). \overline{f^1} \langle SS(a) \rangle \mid P_3^1 \mid \overline{e^2} \langle ns^2 \rangle \mid e^2(a). \overline{f^2} \langle SS(a) \rangle \mid P_3^2 \equiv$$

$$\begin{aligned} S^{II} \mid \overline{e^1} \langle ns^1 \rangle \mid e^1(a). \overline{f^1} \langle SS(a) \rangle \mid f^1(b). \overline{v^1} \langle b \rangle. \overline{cc} \langle (n_{SN_1}, b) \rangle \\ \mid \overline{e^2} \langle ns^2 \rangle \mid e^2(a). \overline{f^2} \langle SS(a) \rangle \mid f^2(b). \overline{v^2} \langle b \rangle. \overline{cc} \langle (n_{SN_2}, b) \rangle \equiv \end{aligned}$$

$$\begin{aligned}
& S^I \mid \bar{e}^1 \langle ns^1 \rangle \mid e^1(a). \bar{f}^1 \langle SS(a) \rangle \mid f^1(b). \bar{v}^1 \langle b \rangle. \bar{c}\bar{c} \langle (n_{SN_1}, b) \rangle \\
& \quad \mid \underbrace{\nu_{n_{SN_1}} * \left( \prod_{m \in M} Q_m^1 \mid T^1 \mid P^1 \right)}_{SN_1} \mid R_{SN}^1 \\
& \mid \bar{e}^2 \langle ns^2 \rangle \mid e^2(a). \bar{f}^2 \langle SS(a) \rangle \mid f^2(b). \bar{v}^2 \langle b \rangle. \bar{c}\bar{c} \langle (n_{SN_2}, b) \rangle \\
& \quad \mid \underbrace{\nu_{n_{SN_2}} * \left( \prod_{m \in M} Q_m^2 \mid T^2 \mid P^2 \right)}_{SN_2} \mid R_{SN}^2 \longrightarrow
\end{aligned}$$

$$\begin{aligned}
& S^I \mid \bar{e}^1 \langle ns^1 \rangle \mid e^1(a). \bar{f}^1 \langle SS(a) \rangle \mid f^1(b). \bar{v}^1 \langle b \rangle. \bar{c}\bar{c} \langle (n_{SN_1}, b) \rangle \\
& \quad \mid \left( \prod_{m \in M} Q_m^1 \mid T^1 \mid P^1 \right) \mid SN_1 \\
& \mid \bar{e}^2 \langle ns^2 \rangle \mid e^2(a). \bar{f}^2 \langle SS(a) \rangle \mid f^2(b). \bar{v}^2 \langle b \rangle. \bar{c}\bar{c} \langle (n_{SN_2}, b) \rangle \\
& \quad \mid \left( \prod_{m \in M} Q_m^2 \mid T^2 \mid P^2 \right) \mid SN_2 \equiv
\end{aligned}$$

$$\begin{aligned}
& S^{II} \mid \bar{e}^1 \langle ns^1 \rangle \mid e^1(a). \bar{f}^1 \langle SS(a) \rangle \mid f^1(b). \bar{v}^1 \langle b \rangle. \bar{c}\bar{c} \langle (n_{SN_1}, b) \rangle \\
& \quad \mid \left( \prod_{m \in M} Q_m^1 \right) \mid T^1 \mid P^1 \\
& \mid \bar{e}^2 \langle ns^2 \rangle \mid e^2(a). \bar{f}^2 \langle SS(a) \rangle \mid f^2(b). \bar{v}^2 \langle b \rangle. \bar{c}\bar{c} \langle (n_{SN_2}, b) \rangle \\
& \quad \mid \left( \prod_{m \in M} Q_m^2 \right) \mid T^2 \mid P^2 \equiv
\end{aligned}$$

$$\begin{aligned}
& S^{II} \mid \bar{e}^1 \langle ns^1 \rangle \mid e^1(a). \bar{f}^1 \langle SS(a) \rangle \mid f^1(b). \bar{v}^1 \langle b \rangle. \bar{c}\bar{c} \langle (n_{SN_1}, b) \rangle \\
& \quad \mid \left( \prod_{m \in M} Q_{m1}^1 \mid Q_{m2}^1 \mid Q_{m3}^1 + Q_{m4}^1 \right) \mid T^1 \mid P^1 \\
& \mid \bar{e}^2 \langle ns^2 \rangle \mid e^2(a). \bar{f}^2 \langle SS(a) \rangle \mid f^2(b). \bar{v}^2 \langle b \rangle. \bar{c}\bar{c} \langle (n_{SN_2}, b) \rangle \\
& \quad \mid \left( \prod_{m \in M} Q_{m1}^2 \mid Q_{m2}^2 \mid Q_{m3}^2 + Q_{m4}^2 \right) \mid T^2 \mid P^2 \equiv
\end{aligned}$$

$$\begin{aligned}
 & S^{II} | \bar{e}^1 \langle ns^1 \rangle | e^1(a). \bar{f}^1 \langle SS(a) \rangle | f^1(b). \bar{v}^1 \langle b \rangle. \bar{c}\bar{c} \langle (n_{SN_1}, b) \rangle \\
 & | \left( \prod_{m \in M} v^1(b). C_m(b, x_1 :: x_k) + cc(\lambda(x, y)(x, y)) \text{ if } x = n_{SN_1} \text{ then} \right. \\
 & \quad C_m(y, x_1 :: x_k) + \bar{d}^1 \langle (x_1 :: x_k) \rangle | Q_{m_2}^1 | Q_{m_3}^1 + Q_{m_4}^1 | T^1 | P^1 \\
 & \quad \left. | \bar{e}^2 \langle ns^2 \rangle | e^2(a). \bar{f}^2 \langle SS(a) \rangle | f^2(b). \bar{v}^2 \langle b \rangle. \bar{c}\bar{c} \langle (n_{SN_2}, b) \rangle \right. \\
 & | \left( \prod_{m \in M} v^2(b). C_m(b, x_1 :: x_k) + cc(\lambda(x, y)(x, y)) \text{ if } x = n_{SN_2} \text{ then} \right. \\
 & \quad \left. C_m(y, x_1 :: x_k) + \bar{d}^2 \langle (x_1 :: x_k) \rangle | Q_{m_2}^2 | Q_{m_3}^2 + Q_{m_4}^2 | T^2 | P^2 \longrightarrow^+
 \end{aligned}$$

$$\begin{aligned}
 S^{II} & | \left( \prod_{m \in M} \bar{d}^1 \langle \underbrace{x_1 :: x_k}_{y_1} \rangle \right) | Q_{m_2}^1 | Q_{m_3}^1 | T^1 | P^1 \\
 & | \left( \prod_{m \in M} \bar{d}^2 \langle \underbrace{x_1 :: x_k}_{y_2} \rangle \right) | Q_{m_2}^2 | Q_{m_3}^2 | T^2 | P^2 \equiv
 \end{aligned}$$

$$\begin{aligned}
 S^{II} & | \left( \prod_{m \in M} \bar{d}^1 \langle y_1 \rangle | d^1(e). \bar{g}^1 \langle LDDF(e) \rangle | Q_{m_3}^1 | T^1 | P^1 \right. \\
 & \left. | \left( \prod_{m \in M} \bar{d}^2 \langle y_2 \rangle | d^2(e). \bar{g}^2 \langle LDDF(e) \rangle | Q_{m_3}^2 | T^2 | P^2 \longrightarrow
 \right.
 \end{aligned}$$

$$\begin{aligned}
 S^{II} & | \left( \prod_{m \in M} \bar{g}^1 \langle LDDF(y_1) \rangle | Q_{m_3}^1 | T^1 | P^1 \right. \\
 & \left. | \left( \prod_{m \in M} \bar{g}^2 \langle LDDF(y_2) \rangle | Q_{m_3}^2 | T^2 | P^2 \equiv
 \right.
 \end{aligned}$$

$$\begin{aligned}
 S^{II} & | \left( \prod_{m \in M} \bar{g}^1 \langle LDDF(y_1) \rangle | g^1(i). \bar{h}^1 \langle KBU(i) \rangle \right) | T^1 | P^1 \\
 & | \left( \prod_{m \in M} \bar{g}^2 \langle LDDF(y_2) \rangle | g^2(i). \bar{h}^2 \langle KBU(i) \rangle \right) | T^2 | P^2 \longrightarrow
 \end{aligned}$$

$$\begin{aligned}
 S^{II} & | \left( \prod_{m \in M} \bar{h}^1 \langle \underbrace{KBU(LDDF(y_1))}_{kbu_m^1} \rangle \right) | T^1 | P^1 \\
 & | \left( \prod_{m \in M} \bar{h}^2 \langle \underbrace{KBU(LDDF(y_2))}_{kbu_m^2} \rangle \right) | T^2 | P^2 \equiv
 \end{aligned}$$

$$\begin{aligned}
S^{II} &| \left( \prod_{m \in M} \bar{h}^1 \langle kbu_m^1 \rangle \right) | T_1^1 | T_2^1 | P^1 \\
&| \left( \prod_{m \in M} \bar{h}^2 \langle kbu_m^2 \rangle \right) | T_1^2 | T_2^2 | P^2 \equiv
\end{aligned}$$

$$\begin{aligned}
S^{II} &| \left( \prod_{m \in M} \bar{h}^1 \langle kbu_m^1 \rangle \right) | C_{KBV}^1(\square) | T_2^1 | P^1 \\
&| \left( \prod_{m \in M} \bar{h}^2 \langle kbu_m^2 \rangle \right) | C_{KBV}^2(\square) | T_2^2 | P^2 \equiv
\end{aligned}$$

$$\begin{aligned}
S^{II} &| \left( \prod_{m \in M} \bar{h}^1 \langle kbu_m^1 \rangle \right) | h^1(b).C_{KBV}(b, y_1 :: y_M) \\
&\quad + \bar{k}^1 \langle y_1 :: y_M \rangle | T_2^1 | P^1 \\
&| \left( \prod_{m \in M} \bar{h}^2 \langle kbu_m^2 \rangle \right) | h^2(b).C_{KBV}(b, y_1 :: y_M) \\
&\quad + \bar{k}^2 \langle y_1 :: y_M \rangle | T_2^2 | P^2 \longrightarrow^+
\end{aligned}$$

$$S^{II} | \bar{k}^1 \langle kbu_1^1 :: kbu_M^1 \rangle | T_2^1 | P^1 | \bar{k}^2 \langle kbu_1^2 :: kbu_M^2 \rangle | T_2^2 | P^2 \equiv$$

$$\begin{aligned}
S^{II} &| \underbrace{\bar{k}^1 \langle kbu_1^1 :: kbu_M^1 \rangle}_{z_1} | k^1(e).\bar{w}^1 \langle NS(e) \rangle | P^1 | \\
&\quad \underbrace{\bar{k}^2 \langle kbu_1^2 :: kbu_M^2 \rangle}_{z_2} | k^2(e).\bar{w}^2 \langle NS(e) \rangle | P^2 \equiv
\end{aligned}$$

$$\begin{aligned}
&S^{II} | \bar{k}^1 \langle z_1 \rangle | k^1(e).\bar{w}^1 \langle NS(e) \rangle | \\
P^1 &| \bar{k}^2 \langle z_2 \rangle | k^2(e).\bar{w}^2 \langle NS(e) \rangle | P^2 \longrightarrow^+
\end{aligned}$$

$$S^{II} | \bar{w}^1 \langle NS(z_1) \rangle | P^1 | \bar{w}^2 \langle NS(z_2) \rangle | P^2 \equiv$$

$$\underbrace{S^I | \bar{w}^1 \langle NS(z_1) \rangle | P^1 | SN_1 | \bar{w}^2 \langle NS(z_2) \rangle | P^2 | SN_2}_{\text{Resolved State}}$$

The resolved state was achieved and therefore shown that after the certain number of iterations the network  $S$  resolves to  $S'$ .



## B.2 $N + 1$ Case

Following the induction hypothesis it can be assumed that the case where  $|I| = N$ ,  $S$  reaches the resolved state, and so to complete the proof the final step is to show what happens when an extra Sensing Node (SN) is added to the network, i.e. the number of nodes in the network is  $|I| = N + 1$ . The  $S$  structure in this case is defined as,

$$S \equiv (\nu\vec{c}\hat{c}) \left( \prod_{i,j \in I, i \neq j} sl_i \bowtie sl_j \right) \mid \prod_{i \in I} SN_i$$

The flow of the proof is the same as in the base case, i.e. first show that the first item of the proof occurs and finish the proof by showing that the second item also occurs. When the network is instantiated, none of the Sensing Nodes (SNs) knows which channel to sense. Therefore there is an initialization process to be done, which is depicted next. So first are computed the steps from the initial state until the resolved state. By induction hypothesis is assumed that the case  $|I| = N$  is resolved, then here for illustration purposes it is shown explicitly that the reduction sequence of two sensing nodes while the reduction of the remaining sensing nodes is implicit.

$$(\nu\vec{c}\hat{c}) \left( \prod_{i,j \in I, i \neq j} sl_i \bowtie sl_j \right) \mid \prod_{i \in I} SN_i \equiv$$

$$(\nu\vec{c}\hat{c}) \left( \prod_{i,j \in I, i \neq j} sl_i \bowtie sl_j \right) \mid \prod_{i=1}^{N+1} SN_i \equiv$$

$$(\nu\vec{c}\hat{c}) \left( \prod_{i,j \in I, i \neq j} sl_i \bowtie sl_j \right) \mid SN_1 \mid SN_2 \mid \prod_{i=3}^{N+1} SN_i \equiv$$

$$\underbrace{(\nu\vec{c}\hat{c}) \left( \prod_{i,j \in I, i \neq j} sl_i \bowtie sl_j \right) \mid \prod_{i=3}^{N+1} SN_i}_{S^I} \mid SN_1 \mid SN_2 \equiv$$

$$S^I \mid \underbrace{\nu_{n_{SN_1}} * \left( \prod_{m \in M} Q_m^1 \mid T^1 \mid P^1 \right)}_{SN_1} \mid R_{SN}^1 \mid$$

$$\underbrace{\nu_{n_{SN_2}} * \left( \prod_{m \in M} Q_m^2 \mid T^2 \mid P^2 \right)}_{SN_2} \mid R_{SN}^2 \longrightarrow$$

$$S^I \mid \left( \prod_{m \in M} Q_m^1 \right) \mid T^1 \mid P^1 \mid SN_1 \mid \left( \prod_{m \in M} Q_m^2 \right) \mid T^2 \mid P^2 \mid SN_2 \equiv$$

$$\underbrace{S^I \mid SN_1 \mid SN_2}_{S^{II}} \mid \left( \prod_{m \in M} Q_m^1 \right) \mid T^1 \mid P^1 \mid \left( \prod_{m \in M} Q_m^2 \right) \mid T^2 \mid P^2 \equiv$$

$$S^{II} \mid \left( \prod_{m \in M} Q_{m_1}^1 \mid Q_{m_2}^1 \mid Q_{m_3}^1 + Q_{m_4}^1 \right) \mid T^1 \mid P^1 \mid$$

$$\left( \prod_{m \in M} Q_{m_1}^2 \mid Q_{m_2}^2 \mid Q_{m_3}^2 + Q_{m_4}^2 \right) \mid T^2 \mid P^2 \longrightarrow$$

$$S^{II} \mid \left( \prod_{m \in M} Q_{m_4}^1 \right) \mid T^1 \mid P^1 \mid \left( \prod_{m \in M} Q_{m_4}^2 \right) \mid T^2 \mid P^2 \longrightarrow$$

$$S^{II} \mid \left( \prod_{m \in M} \bar{h}^1 \langle KBU(\square) \rangle \right) \mid T^1 \mid P^1 \mid \left( \prod_{m \in M} \bar{h}^2 \langle KBU(\square) \rangle \right) \mid T^2 \mid P^2 \equiv$$

$$S^{II} \mid \left( \prod_{m \in M} \underbrace{\bar{h}^1 \langle KBU(\square) \rangle}_{b_m^1} \right) \mid T_1^1 \mid T_2^1 \mid P^1 \mid$$

$$\left( \prod_{m \in M} \underbrace{\bar{h}^2 \langle KBU(\square) \rangle}_{b_m^2} \right) \mid T_1^2 \mid T_2^2 \mid P^2 \equiv$$

$$S^{II} \mid \left( \prod_{m \in M} \bar{h}^1 \langle b_m^1 \rangle \right) \mid T_1^1 \mid T_2^1 \mid P^1 \mid \left( \prod_{m \in M} \bar{h}^2 \langle b_m^2 \rangle \right) \mid T_1^2 \mid T_2^2 \mid P^2 \equiv$$

$$S^{II} \mid \left( \prod_{m \in M} \bar{h}^1 \langle b_m^1 \rangle \right) \mid C_{KBU}^1 (\emptyset) \mid T_2^1 \mid P^1 \mid \\ \left( \prod_{m \in M} \bar{h}^2 \langle b_m^2 \rangle \right) \mid C_{KBU}^2 (\emptyset) \mid T_2^2 \mid P^2 \equiv$$

$$S^{II} \mid \left( \prod_{m \in M} \bar{h}^1 \langle b_m^1 \rangle \right) \mid h^1(b).C_{KBU}^1(b, y_1 :: y_M) \\ + \bar{k}^1 \langle y_1 :: y_M \rangle \mid T_2^1 \mid P^1 \mid \\ \left( \prod_{m \in M} \bar{h}^2 \langle b_m^2 \rangle \right) \mid h^2(b).C_{KBU}^2(b, y_1 :: y_M) \\ + \bar{k}^2 \langle y_1 :: y_M \rangle \mid T_2^2 \mid P^2 \longrightarrow^+$$

$$S^{II} \mid \bar{k}^1 \langle y_1 :: y_M \rangle \mid T_2^1 \mid P^1 \mid \bar{k}^2 \langle y_1 :: y_M \rangle \mid T_2^2 \mid P^2 \equiv$$

$$S^{II} \mid \bar{k}^1 \langle y_1 :: y_M \rangle \mid k^1(e).\bar{w} \langle NS(e) \rangle \mid P^1 \mid \\ \bar{k}^2 \langle y_1 :: y_M \rangle \mid k^2(e).\bar{w} \langle NS(e) \rangle \mid P^2 \longrightarrow^+$$

$$S^{II} \mid \bar{w} \langle NS(y_1 :: y_M) \rangle \mid P^1 \mid \bar{w} \langle NS(y_1 :: y_M) \rangle \mid P^2 \longrightarrow^+$$

$$S^{II} \mid \underbrace{\bar{w} \langle NS(y_1 :: y_M) \rangle}_{ss_1} \mid P^1 \mid \underbrace{\bar{w} \langle NS(y_1 :: y_M) \rangle}_{ss_2} \mid P^2 \equiv$$

$$\underbrace{S^{II} \mid \bar{w} \langle ss_1 \rangle \mid P^1 \mid \bar{w} \langle ss_2 \rangle \mid P^2}_{ResolvedState} \equiv$$

So the network reached the resolved state. In the next step is shown that through a sequence of reductions steps the network tends to the same resolved state.

$$S^{II} \mid \bar{w} \langle ss_1 \rangle \mid P_1^1 \mid P_2^1 \mid P_3^1 \mid \bar{w} \langle ss_2 \rangle \mid P_1^2 \mid P_2^2 \mid P_3^2 \equiv$$

$$S^{II} | \bar{w}\langle ss_1 \rangle | w^1(a).\bar{e}^1\langle a \rangle | P_2^1 | P_3^1 | \bar{w}\langle ss_2 \rangle || w^2(a).\bar{e}^2\langle a \rangle | P_2^2 | P_3^2 \longrightarrow$$

$$S^{II} | \bar{e}^1\langle ss_1 \rangle | P_2^1 | P_3^1 | \bar{e}^2\langle ss_2 \rangle | P_2^2 | P_3^2 \equiv$$

$$S^{II} | \bar{e}^1\langle ss_1 \rangle | e^1(a).\bar{f}^1\langle SS(a) \rangle | P_3^1 | \bar{e}^2\langle ss_2 \rangle | e^2(a).\bar{f}^2\langle SS(a) \rangle | P_3^2 \equiv$$

$$S^{II} | \bar{e}^1\langle ss_1 \rangle | e^1(a).\bar{f}^1\langle SS(a) \rangle | f^1(b).\bar{v}^1\langle b \rangle.\bar{cc}\langle (n_{SN_1}, b) \rangle \\ | \bar{e}^2\langle ss_2 \rangle | e^2(a).\bar{f}^2\langle SS(a) \rangle | f^2(b).\bar{v}^2\langle b \rangle.\bar{cc}\langle (n_{SN_2}, b) \rangle \equiv$$

$$S^I | \bar{e}^1\langle ss_1 \rangle | e^1(a).\bar{f}^1\langle SS(a) \rangle | f^1(b).\bar{v}^1\langle b \rangle.\bar{cc}\langle (n_{SN_1}, b) \rangle \\ | \underbrace{\nu_{n_{SN_1}} * \left( \prod_{m \in M} Q_m^1 | T^1 | P^1 \right)}_{SN_1} | R_{SN}^1 \\ | \bar{e}^2\langle ss_2 \rangle | e^2(a).\bar{f}^2\langle SS(a) \rangle | f^2(b).\bar{v}^2\langle b \rangle.\bar{cc}\langle (n_{SN_2}, b) \rangle \\ | \underbrace{\nu_{n_{SN_2}} * \left( \prod_{m \in M} Q_m^2 | T^2 | P^2 \right)}_{SN_2} | R_{SN}^2 \longrightarrow$$

### B.2.1 $N + 1 < b(cc, sl_i)$

Here is considered the case where the number of SNs is lower than  $b(cc, sl_i)$ , the capacity of the control channel at the  $sl_i$  location.

$$S^I | \bar{e}^1\langle ss_1 \rangle | e^1(a).\bar{f}^1\langle SS(a) \rangle | f^1(b).\bar{v}^1\langle b \rangle.\bar{cc}\langle (n_{SN_1}, b) \rangle \\ | \left( \prod_{m \in M} Q_m^1 | T^1 | P^1 \right) | SN_1 \\ | \bar{e}^2\langle ss_2 \rangle | e^2(a).\bar{f}^2\langle SS(a) \rangle | f^2(b).\bar{v}^2\langle b \rangle.\bar{cc}\langle (n_{SN_2}, b) \rangle \\ | \left( \prod_{m \in M} Q_m^2 | T^2 | P^2 \right) | SN_2 \equiv$$

$$\begin{aligned}
 S^{II} &| \bar{e}^1 \langle ss_1 \rangle | e^1(a). \bar{f}^1 \langle SS(a) \rangle | f^1(b). \bar{v}^1 \langle b \rangle. \bar{c}\bar{c} \langle (n_{SN_1}, b) \rangle \\
 &| \left( \prod_{m \in M} Q_m^1 \right) | T^1 | P^1 \\
 &| \bar{e}^2 \langle ss_2 \rangle | e^2(a). \bar{f}^2 \langle SS(a) \rangle | f^2(b). \bar{v}^2 \langle b \rangle. \bar{c}\bar{c} \langle (n_{SN_2}, b) \rangle \\
 &| \left( \prod_{m \in M} Q_m^2 \right) | T^2 | P^2 \equiv
 \end{aligned}$$

$$\begin{aligned}
 S^{II} &| \bar{e}^1 \langle ss_1 \rangle | e^1(a). \bar{f}^1 \langle SS(a) \rangle | f^1(b). \bar{v}^1 \langle b \rangle. \bar{c}\bar{c} \langle (n_{SN_1}, b) \rangle \\
 &| \left( \prod_{m \in M} Q_{m_1}^1 | Q_{m_2}^1 | Q_{m_3}^1 + Q_{m_4}^1 \right) | T^1 | P^1 \\
 &| \bar{e}^2 \langle ss_2 \rangle | e^2(a). \bar{f}^2 \langle SS(a) \rangle | f^2(b). \bar{v}^2 \langle b \rangle. \bar{c}\bar{c} \langle (n_{SN_2}, b) \rangle \\
 &| \left( \prod_{m \in M} Q_{m_1}^2 | Q_{m_2}^2 | Q_{m_3}^2 + Q_{m_4}^2 \right) | T^2 | P^2 \equiv
 \end{aligned}$$

$$\begin{aligned}
 &S^{II} | \bar{e}^1 \langle ss_1 \rangle | e^1(a). \bar{f}^1 \langle SS(a) \rangle | f^1(b). \bar{v}^1 \langle b \rangle. \bar{c}\bar{c} \langle (n_{SN_1}, b) \rangle \\
 &| \left( \prod_{m \in M} v^1(b). C_m(b, x_1 :: x_k) + cc(\lambda(x, y)(x, y)) \text{ if } x = n_{SN_1} \text{ then} \right. \\
 &\quad \left. C_m(y, x_1 :: x_k) + \bar{d}^1 \langle (x_1 :: x_k) \rangle | Q_{m_2}^1 | Q_{m_3}^1 + Q_{m_4}^1 \right) | T^1 | P^1 \\
 &| \bar{e}^2 \langle ss_2 \rangle | e^2(a). \bar{f}^2 \langle SS(a) \rangle | f^2(b). \bar{v}^2 \langle b \rangle. \bar{c}\bar{c} \langle (n_{SN_2}, b) \rangle \\
 &| \left( \prod_{m \in M} v^2(b). C_m(b, x_1 :: x_k) + cc(\lambda(x, y)(x, y)) \text{ if } x = n_{SN_2} \text{ then} \right. \\
 &\quad \left. C_m(y, x_1 :: x_k) + \bar{d}^2 \langle (x_1 :: x_k) \rangle | Q_{m_2}^2 | Q_{m_3}^2 + Q_{m_4}^2 \right) | T^2 | P^2 \longrightarrow^+
 \end{aligned}$$

$$\begin{aligned}
 S^{II} &| \left( \prod_{m \in M} \bar{d}^1 \langle \underbrace{x_1 :: x_k}_{y_1} \rangle \right) | Q_{m_2}^1 | Q_{m_3}^1 | T^1 | P^1 \\
 &| \left( \prod_{m \in M} \bar{d}^2 \langle \underbrace{x_1 :: x_k}_{y_2} \rangle \right) | Q_{m_2}^2 | Q_{m_3}^2 | T^2 | P^2 \equiv
 \end{aligned}$$

$$\begin{aligned}
 S^{II} &| \left( \prod_{m \in M} \bar{d}^1 \langle y_1 \rangle | d^1(e). \bar{g}^1 \langle LDDF(e) \rangle | Q_{m_3}^1 \right) | T^1 | P^1 \\
 &| \left( \prod_{m \in M} \bar{d}^2 \langle y_2 \rangle | d^2(e). \bar{g}^2 \langle LDDF(e) \rangle | Q_{m_3}^2 \right) | T^2 | P^2 \longrightarrow
 \end{aligned}$$



$$S^{II} | \bar{k}^1 \langle z_1 \rangle | k^1(e) \cdot \bar{w}^1 \langle NS(e) \rangle | P^1 | \\ \bar{k}^2 \langle z_2 \rangle | k^2(e) \cdot \bar{w}^2 \langle NS(e) \rangle | P^2 \longrightarrow^+$$

$$S^{II} | \bar{w}^1 \langle NS(z_1) \rangle | P^1 | \bar{w}^2 \langle NS(z_2) \rangle | P^2 \equiv$$

$$\underbrace{S^I | \bar{w}^1 \langle NS(z_1) \rangle | P^1 | SN_1 | \bar{w}^2 \langle NS(z_2) \rangle | P^2 | SN_2}_{\text{Resolved State}}$$

It was shown that the network  $S$  resolves to  $S'$  after the certain number of reduction steps.

### B.2.2 $N + 1 > b(cc, sl_i)$

In this case when the SNs start reporting to the other SNs through the  $cc$ , they overcome the channel capacity which is given by  $b(cc, sl_i)$ , and therefore some of the SNs messages will be dropped following the  $R - DROP$  reduction rule in Table 3.5.

$$S^I | \bar{e}^1 \langle ss_1 \rangle | e^1(a) \cdot \bar{f}^1 \langle SS(a) \rangle | f^1(b) \cdot \bar{v}^1 \langle b \rangle \cdot \bar{cc} \langle (n_{SN_1}, b) \rangle \\ | \left( \prod_{m \in M} Q_m^1 | T^1 | P^1 \right) | SN_1 \\ | \bar{e}^2 \langle ss_2 \rangle | e^2(a) \cdot \bar{f}^2 \langle SS(a) \rangle | f^2(b) \cdot \bar{v}^2 \langle b \rangle \cdot \bar{cc} \langle (n_{SN_2}, b) \rangle \\ | \left( \prod_{m \in M} Q_m^2 | T^2 | P^2 \right) | SN_2 \equiv$$

$$S^{II} | \bar{e}^1 \langle ss_1 \rangle | e^1(a) \cdot \bar{f}^1 \langle SS(a) \rangle | f^1(b) \cdot \bar{v}^1 \langle b \rangle \cdot \bar{cc} \langle (n_{SN_1}, b) \rangle \\ | \left( \prod_{m \in M} Q_m^1 \right) | T^1 | P^1 \\ | \bar{e}^2 \langle ss_2 \rangle | e^2(a) \cdot \bar{f}^2 \langle SS(a) \rangle | f^2(b) \cdot \bar{v}^2 \langle b \rangle \cdot \bar{cc} \langle (n_{SN_2}, b) \rangle \\ | \left( \prod_{m \in M} Q_m^2 \right) | T^2 | P^2 \equiv$$

$$\begin{aligned}
 & S^{II} | \overline{e^1} \langle ss_1 \rangle | e^1(a). \overline{f^1} \langle SS(a) \rangle | f^1(b). \overline{v^1} \langle b \rangle. \overline{cc} \langle (n_{SN_1}, b) \rangle \\
 & \quad | \left( \prod_{m \in M} Q_{m1}^1 | Q_{m2}^1 | Q_{m3}^1 + Q_{m4}^1 \right) | T^1 | P^1 \\
 & | \overline{e^2} \langle ss_2 \rangle | e^2(a). \overline{f^2} \langle SS(a) \rangle | f^2(b). \overline{v^2} \langle b \rangle. \overline{cc} \langle (n_{SN_2}, b) \rangle \\
 & \quad | \left( \prod_{m \in M} Q_{m1}^2 | Q_{m2}^2 | Q_{m3}^2 + Q_{m4}^2 \right) | T^2 | P^2 \equiv \\
 & S^{II} | \overline{e^1} \langle ss_1 \rangle | e^1(a). \overline{f^1} \langle SS(a) \rangle | f^1(b). \overline{v^1} \langle b \rangle. \overline{cc} \langle (n_{SN_1}, b) \rangle \\
 & | \left( \prod_{m \in M} v^1(b). C_m(b, x_1 :: x_k) + cc(\lambda(x, y)(x, y)) \text{ if } x = n_{SN_1} \text{ then} \right. \\
 & \quad C_m(y, x_1 :: x_k) + \overline{d^1} \langle (x_1 :: x_k) \rangle | Q_{m2}^1 | Q_{m3}^1 + Q_{m4}^1 | T^1 | P^1 \\
 & \quad \left. | \overline{e^2} \langle ss_2 \rangle | e^2(a). \overline{f^2} \langle SS(a) \rangle | f^2(b). \overline{v^2} \langle b \rangle. \overline{cc} \langle (n_{SN_2}, b) \rangle \right. \\
 & \quad \left. | \left( \prod_{m \in M} v^2(b). C_m(b, x_1 :: x_k) + cc(\lambda(x, y)(x, y)) \text{ if } x = n_{SN_2} \text{ then} \right. \right. \\
 & \quad \left. \left. Collect_m(y, x_1 :: x_k) + \overline{d^2} \langle (x_1 :: x_k) \rangle | Q_{m2}^2 | Q_{m3}^2 + Q_{m4}^2 | T^2 | P^2 \longrightarrow^+ \right. \right.
 \end{aligned}$$

In this sequence of reductions the  $SN$ s all messages above the channel capacity  $b(cc, sl_i)$  are discarded.

$$\begin{aligned}
 & S^{II} | \left( \prod_{m \in M} \overline{d^1} \langle \underbrace{x_1 :: x_k}_{y_1} \rangle \right) | Q_{m2}^1 | Q_{m3}^1 | T^1 | P^1 \\
 & | \left( \prod_{m \in M} \overline{d^2} \langle \underbrace{x_1 :: x_k}_{y_2} \rangle \right) | Q_{m2}^2 | Q_{m3}^2 | T^2 | P^2 \equiv \\
 & S^{II} | \left( \prod_{m \in M} \overline{d^1} \langle y_1 \rangle | d^1(e). \overline{g^1} \langle LDDF(e) \rangle | Q_{m3}^1 \right) | T^1 | P^1 \\
 & | \left( \prod_{m \in M} \overline{d^2} \langle y_2 \rangle | d^2(e). \overline{g^2} \langle LDDF(e) \rangle | Q_{m3}^2 \right) | T^2 | P^2 \longrightarrow \\
 & S^{II} | \left( \prod_{m \in M} \overline{g^1} \langle LDDF(y_1) \rangle | Q_{m3}^1 \right) | T^1 | P^1 \\
 & | \left( \prod_{m \in M} \overline{g^2} \langle LDDF(y_2) \rangle | Q_{m3}^2 \right) | T^2 | P^2 \equiv
 \end{aligned}$$



$$S^{II} | \left( \prod_{m \in M} \overline{g^1} \langle LDDF(y_1) \rangle | g^1(i). \overline{h^1} \langle KBU(i) \rangle \right) | T^1 | P^1$$

$$| \left( \prod_{m \in M} \overline{g^2} \langle LDDF(y_2) \rangle | g^2(i). \overline{h^2} \langle KBU(i) \rangle \right) | T^2 | P^2 \longrightarrow$$

$$S^{II} | \left( \prod_{m \in M} \overline{h^1} \langle KBU(LDDF(y_1)) \rangle \right) | T^1 | P^1$$

$$| \left( \prod_{m \in M} \overline{h^2} \langle KBU(LDDF(y_2)) \rangle \right) | T^2 | P^2 \equiv$$

$$S^{II} | \left( \prod_{m \in M} \overline{h^1} \langle KBU(LDDF(y_1)) \rangle \right) | T_1^1 | T_2^1 | P^1$$

$$| \left( \prod_{m \in M} \overline{h^2} \langle KBU(LDDF(y_2)) \rangle \right) | T_1^2 | T_2^2 | P^2 \equiv$$

$$S^{II} | \left( \prod_{m \in M} \overline{h^1} \langle KBU(LDDF(y_1)) \rangle \right) | C_{KBU}^1(\square) | T_2^1 | P^1$$

$$| \left( \prod_{m \in M} \overline{h^2} \langle KBU(LDDF(y_2)) \rangle \right) | C_{KBU}^2(\square) | T_2^2 | P^2 \equiv$$

$$S^{II} | \left( \prod_{m \in M} \overline{h^1} \langle KBU(LDDF(y_1)) \rangle \right) | h^1(b). C_{KBU}^1(b, y_1 :: y_M)$$

$$+ \overline{k^1} \langle y_1 :: y_M \rangle | T_2^1 | P^1$$

$$| \left( \prod_{m \in M} \overline{h^2} \langle KBU(LDDF(y_2)) \rangle \right) | h^2(b). C_{KBU}^2(b, y_1 :: y_M)$$

$$+ \overline{k^2} \langle y_1 :: y_M \rangle | T_2^2 | P^2 \longrightarrow^+$$

$$S^{II} | \overline{k^1} \langle y_1 :: y_M \rangle | T_2^1 | P^1 | \overline{k^2} \langle y_1 :: y_M \rangle | T_2^2 | P^2 \equiv$$

$$S^{II} | \overline{k^1} \underbrace{\langle y_1 :: y_M \rangle}_{z_1} | k^1(e). \overline{w^1} \langle NS(e) \rangle | P^1$$

$$| \overline{k^2} \underbrace{\langle y_1 :: y_M \rangle}_{z_2} | k^2(e). \overline{w^2} \langle NS(e) \rangle | P^2 \equiv$$

$$S^{II} | \overline{k^1} \langle z_1 \rangle | k^1(e). \overline{w^1} \langle NS(e) \rangle | P^1$$

$$| \overline{k^2} \langle z_2 \rangle | k^2(e). \overline{w^2} \langle NS(e) \rangle | P^2 \longrightarrow^+$$

$$S^{II} | \overline{w^1} \langle NS(z_1) \rangle | P^1 | \overline{w^2} \langle NS(z_2) \rangle | P^2 \equiv$$

$$\underbrace{S^I | \overline{w^1} \langle NS(z_1) \rangle | P^1 | SN_1 | \overline{w^2} \langle NS(z_2) \rangle | P^2 | SN_2}_{\text{Resolved State}}$$

So the resolved state was achieved and therefore shown that after a certain number of reduction steps the network  $S$  resolves to  $S'$   $\square$



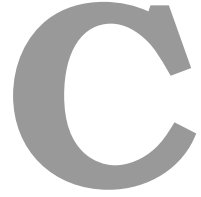

## Appendix - Relay Topology Induction Proof

The theorem for the Relay Assisted Topology which states the correctness is given by the following:

**Theorem 5.** *Let  $S$  be the following networks:*

$$S \equiv (\nu \vec{c}\vec{c}) \left( \prod_{j \in J} cl \bowtie rl_j \mid \prod_{j \in J} \prod_{i \in I_j} sl_i \bowtie rl_j \right) \mid CN \mid \prod_{j \in J} RN_j \mid \prod_{i \in \bigcup_{j \in J} I_j} SN_i \quad (\text{C.1})$$

if  $|\bigcup_{j \in J} I_j| = |I|$ ,  $|J| > 0$ ,  $|I| > 0$  and  $n = |J| + |I|$

Then  $S$  satisfies the following:

1.  $S \longrightarrow^* S'$  where  $S'$  is resolved
2. for any  $S'$  where  $S \longrightarrow^* S'$  and  $S'$  resolved.  $\exists S''$  such that  $S' \longrightarrow^+ S''$ ,  $S''$  is resolved.

*Proof.* The proof of the theorem will be done through induction in the size of  $n$ , where  $n = |J| + |I|$ , as stated in the theorem 5. The proof is composed of

two steps the base case where  $n = 2$ , since that is the minimum size of the network, and  $n + 1$ .

The definition of resolved state in the relay assisted topology is given by,

**Definition 9.**  $S$  is resolved if  $S \equiv S' \mid cl [\overline{cc} \langle n_{CN}, NS(c) \rangle]$  for some  $n_{CN}$  and  $c$ .

## C.1 Base Case

The purpose of the base case proof is to show that the network reaches the resolved state, which if the network is properly constructed then according to Theorem 5 after a cycle that same resolved state will be reached, and therefore we will have proved that for the base case the structure  $S$  is resolved. This proves the first item of the theorem.

As state before the base case in this topology occurs when  $n = 2$ , the minimum size of the network. The network topology in this case is given by,

$$S \equiv \underbrace{(\nu \overline{cc}) (sl \bowtie rl \mid cl \bowtie rl)}_{S^I} \mid SN \mid RN \mid CN$$

To simplify the notation, in the base case we do not included the index of the  $SN$  nor the  $RN$  since there is only one of each.

When the network is instatiated, the Central Node,  $CN$ , needs to send the request to the Sensing Node,  $SN$ , regarding which channel should be sensed. This is assumed to be the network initial state.

So first are computed the steps from the initial state until the resolved state.

$$\underbrace{S^I \mid SN \mid RN}_{S^{II}} \mid CN \equiv$$

$$S^{II} \mid CN \equiv$$

$$S^{II} \mid \underbrace{(\nu n_{CN}) * \left( \prod_{m \in M} Q_m \mid T \right)}_{CN} \mid R \longrightarrow$$

$$S^{II} \mid \left( \prod_{m \in M} Q_m \mid T \right) \mid \underbrace{(\nu n_{CN}) * \left( \prod_{m \in M} Q_m \mid T \right)}_{CN} \mid R \equiv$$

$$S^{II} \mid \left( \prod_{m \in M} Q_m \mid T \right) \mid CN \equiv$$

$$S^{II} \mid \left( \prod_{m \in M} Q_{m1} \mid Q_{m2} \mid Q_{m3} + Q_{m4} \mid T \right) \mid CN \longrightarrow$$

$$S^{II} \mid \left( \prod_{m \in M} \underbrace{Q_{4m}}_{\text{No SN reports available}} \mid T \right) \mid CN \equiv$$

$$S^{II} \mid \left( \prod_{m \in M} \bar{h} \langle \underbrace{KBU(\square)}_{kbu_m} \rangle \mid T \right) \mid CN \equiv$$

$$S^{II} \mid \left( \prod_{m \in M} \bar{h} \langle kbu_m \rangle \mid T_1 \mid T_2 \right) \mid CN \equiv$$

$$S^{II} \mid \left( \prod_{m \in M} \bar{h} \langle kbu_m \rangle \mid (C_{KBU}(\square)) \mid T_2 \right) \mid CN \equiv$$

$$S^{II} \mid \left( \prod_{m \in M} \bar{h} \langle kbu_m \rangle \mid h(b).C_{KBU}(b, y_1 :: y_M) \right. \\ \left. + \bar{k} \langle y_1 :: y_M \rangle \mid T_2 \right) \mid CN \longrightarrow$$

$$S^{II} \mid \bar{k} \langle kbu_1 :: kbu_M \rangle \mid T_2 \mid CN \equiv$$

$$S^{II} \mid \bar{k} \langle kbu_1 :: kbu_M \rangle \mid k(e).\bar{c}\bar{c} \langle (n_{CN}, NS(e)) \rangle \mid CN \longrightarrow$$

$$S^{II} \mid \overline{cc}\langle(n_{CN}, NS(kbu_1 :: kbu_M))\rangle \mid CN \equiv$$

$$\underbrace{S^{II} \mid \overline{cc}\langle(n_{CN}, NS(kbu_1 :: kbu_M))\rangle \mid CN}_{\text{Resolved State}}$$

So the resolved state is reached and from here on the network is initialized. The purpose of this proof is to show that the network reaches the same resolved state after a given number of iterations, as stated in the theorem.

$$S^{II} \mid \overline{cc}\langle(n_{CN}, \underbrace{NS(kbu_1 :: kbu_M)}_{ns})\rangle \mid CN \equiv$$

$$S^{II} \mid \overline{cc}\langle(n_{CN}, ns)\rangle \mid CN \equiv$$

$$S^I \mid SN \mid RN \mid \overline{cc}\langle(n_{CN}, ns)\rangle \mid CN \equiv$$

$$S^I \mid SN \mid \underbrace{(\nu n_{RN}) * RC \mid R_{RN}}_{RN} \mid \overline{cc}\langle(n_{CN}, ns)\rangle \mid CN \longrightarrow$$

$$S^I \mid SN \mid RC \mid \underbrace{(\nu n_{RN}) * RC \mid R_{RN}}_{RN} \mid \overline{cc}\langle(n_{CN}, ns)\rangle \mid CN \equiv$$

$$S^I \mid SN \mid RC \mid RN \mid \overline{cc}\langle(n_{CN}, ns)\rangle \mid CN \equiv$$

$$S^I \mid SN \mid R_1 \mid R_2 \mid RN \mid \overline{cc}\langle(n_{CN}, ns)\rangle \mid CN \equiv$$

$$S^I \mid SN \mid CP([], [], f) \mid R_2 \mid RN \mid \overline{cc}\langle(n_{CN}, ns)\rangle \mid CN \longrightarrow^+$$

$$S^I \mid SN \mid cc(\lambda(x, y)(x, y)).CP(x_1 :: l_1, y_1 :: l_2; f) + \overline{f}\langle(l_1, l_2)\rangle \mid R_2 \mid \\ RN \mid \overline{cc}\langle(n_{CN}, ns)\rangle \mid CN \longrightarrow^+$$

$$S^I \mid SN \mid \overline{f}\langle(n_{CN}, ns)\rangle \mid R_2 \mid RN \mid CN \equiv$$

$$S^I \mid SN \mid \overline{f}\langle(n_{CN}, ns)\rangle \mid f(a, i).\overline{cc}\langle(a, i)\rangle \mid RN \mid CN \longrightarrow$$

$$S^I \mid SN \mid \bar{c}c\langle(n_{CN}, ns)\rangle \mid RN \mid CN \equiv$$

$$S^I \mid RN \mid CN \mid SN \mid \bar{c}c\langle(n_{CN}, ns)\rangle \equiv$$

$$S^I \mid RN \mid CN \mid \underbrace{(\nu n_{SN}) * P \mid R_{SN}}_{SN} \mid \bar{c}c\langle(n_{CN}, ns)\rangle \longrightarrow$$

$$\underbrace{S^I \mid RN \mid CN \mid SN \mid P}_{S^{III}} \mid \bar{c}c\langle(n_{CN}, ns)\rangle \equiv$$

$$S^{III} \mid P \mid \bar{c}c\langle(n_{CN}, ns)\rangle \equiv$$

$$S^{III} \mid P_1 \mid P_2 \mid P_3 \mid \bar{c}c\langle(n_{CN}, ns)\rangle \equiv$$

$$S^{III} \mid cc(\lambda(x, y)(x, y)) \text{ if } x = n_{CN} \text{ then } \bar{e}\langle y \rangle \mid \\ P_2 \mid P_3 \mid \bar{c}c\langle(n_{CN}, ns)\rangle \longrightarrow$$

$$S^{III} \mid \bar{e}\langle ns \rangle \mid P_2 \mid P_3 \equiv$$

$$S^{III} \mid \bar{e}\langle ns \rangle \mid e(a).\bar{f}\langle SS(a) \rangle \mid P_3 \longrightarrow$$

$$S^{III} \mid \bar{f}\langle SS(ns) \rangle \mid P_3 \equiv$$

$$S^{III} \mid \bar{f}\langle SS(ns) \rangle \mid f(b).\bar{c}c\langle(n_{SN}, b)\rangle \longrightarrow$$

$$S^{III} \mid \bar{c}c\langle(n_{SN}, \underbrace{SS(ns)}_{ss})\rangle \equiv$$

$$S^{III} \mid \bar{c}c\langle(n_{SN}, ss)\rangle \equiv$$

$$S^I \mid CN \mid SN \mid RN \mid \bar{c}c\langle(n_{SN}, ss)\rangle \equiv$$



$$S^I \mid CN \mid SN \mid \underbrace{(\nu n_{RN}) * RC \mid R_{RN}}_{RN} \mid \overline{cc}\langle (n_{SN}, ss) \rangle \longrightarrow$$

$$\underbrace{S^I \mid CN \mid SN \mid RN}_{S^{III}} \mid RC \mid \overline{cc}\langle (n_{SN}, ss) \rangle \equiv$$

$$S^{III} \mid RC \mid \overline{cc}\langle (n_{SN}, ss) \rangle \equiv$$

$$S^{III} \mid R_1 \mid R_2 \mid \overline{cc}\langle (n_{SN}, ss) \rangle \equiv$$

$$S^{III} \mid CP(\square, \square; f) \mid R_2 \mid \overline{cc}\langle (n_{SN}, ss) \rangle \longrightarrow$$

$$S^{III} \mid cc(\lambda(x, y)(x, y)).CP(x :: l_1, y :: l_2; f) + \\ \overline{f}\langle l_1, l_2 \rangle \mid R_2 \mid \overline{cc}\langle (n_{SN}, ss) \rangle \longrightarrow$$

$$S^{III} \mid \overline{f}\langle n_{SN}, ss \rangle \mid R_2 \longrightarrow$$

$$S^{III} \mid \overline{f}\langle n_{SN}, ss \rangle \mid f(a, i). \overline{cc}\langle (a, i) \rangle \longrightarrow$$

$$S^{III} \mid \overline{cc}\langle (n_{SN}, ss) \rangle \longrightarrow$$

$$S^I \mid RN \mid SN \mid CN \mid \overline{cc}\langle (n_{SN}, ss) \rangle \equiv$$

$$S^I \mid RN \mid SN \mid \underbrace{(\nu n_{CN}) * \left( \prod_{m \in M} Q_m \mid T \right)}_{CN} \mid R_{CN} \mid \overline{cc}\langle (n_{SN}, ss) \rangle \longrightarrow$$

$$\underbrace{S^I \mid RN \mid SN \mid CN}_{S^{III}} \mid \prod_{m \in M} Q_m \mid T \mid \overline{cc}\langle (n_{SN}, ss) \rangle \equiv$$

$$S^{III} \mid \prod_{m \in M} Q_m \mid T \mid \overline{cc}\langle (n_{SN}, ss) \rangle \equiv$$

$$S^{III} \mid \left( \prod_{m \in M} Q_{m1} \mid Q_{m2} \mid Q_{m3} + Q_{m4} \right) \mid T \mid \overline{cc}\langle (n_{SN}, ss) \rangle \longrightarrow$$

$$S^{III} \mid \left( \prod_{m \in M} Q_{m1} \mid Q_{m2} \mid Q_{m3} \right) \mid T \mid \overline{cc}\langle (n_{SN}, ss) \rangle \equiv$$

$$S^{III} \mid \left( \prod_{m \in M} C_m(\square) \mid Q_{m2} \mid Q_{m3} \right) \mid T \mid \overline{cc}\langle (n_{SN}, ss) \rangle \equiv$$

$$S^{III} \mid \left( \prod_{m \in M} cc(\lambda(x, y)(x, y)) \text{ if } x = n_{CN} \text{ then } C_m(y, x_1 :: x_k) + \right. \\ \left. \overline{d}_m\langle (x_1 :: x_k) \rangle \mid Q_{m2} \mid Q_{m3} \right) \mid T \mid \overline{cc}\langle (n_{SN}, ss) \rangle \longrightarrow$$

$$S^{III} \mid \left( \prod_{m \in M} \overline{d}_m\langle ss \rangle \mid Q_{m2} \mid Q_{m3} \right) \mid T \equiv$$

$$S^{III} \mid \left( \prod_{m \in M} \overline{d}_m\langle ss \rangle \mid d_m(e) \cdot \overline{g}_m\langle LDDF(e) \rangle \mid Q_{m3} \right) \mid T \longrightarrow$$

$$S^{III} \mid \left( \prod_{m \in M} \overline{g}_m\langle LDDF(ss) \rangle \mid Q_{m3} \right) \mid T \equiv$$

$$S^{III} \mid \left( \prod_{m \in M} \overline{g}_m\langle LDDF(ss) \rangle \mid g_m(i) \cdot \overline{h}\langle KBU(i) \rangle \right) \mid T \longrightarrow$$

$$S^{III} \mid \left( \prod_{m \in M} \overline{h}\langle \underbrace{KBU(LDDF(ss))}_{kbu_m} \rangle \right) \mid T \equiv$$

$$S^{III} \mid \prod_{m \in M} \overline{h}\langle kbu_m \rangle \mid T \equiv$$

$$S^{III} \mid \prod_{m \in M} \overline{h}\langle kbu_m \rangle \mid T_1 \mid T_2 \equiv$$

$$S^{III} \mid \prod_{m \in M} \bar{h}\langle kb u_m \rangle \mid (C_{KBU}(\square)) \mid T_2 \equiv$$

$$S^{III} \mid \prod_{m \in M} \bar{h}\langle kb u_m \rangle \mid h(b).C_{KBU}(b, y_1 :: y_M) + \bar{k}\langle y_1 :: y_M \rangle \mid T_2 \longrightarrow$$

$$S^{III} \mid \bar{k}\langle kb u_1 :: kb u_m \rangle \mid T_2 \equiv$$

$$S^{III} \mid \bar{k}\langle kb u_1 :: kb u_m \rangle \mid k(e).\bar{c}\langle (n_{CN}, NS(e)) \rangle \longrightarrow$$

$$S^{III} \mid \bar{c}\langle (n_{CN}, NS(kb u_1 :: kb u_m)) \rangle \equiv$$

$$\underbrace{S^I \mid SN \mid RN \mid CN \mid \bar{c}\langle (n_{CN}, NS(kb u_1 :: kb u_m)) \rangle}_{\text{Resolved State}}$$

The resolved state is achieved and therefore it is shown that after the certain number of iterations the network  $S$  resolves to  $S'$

## C.2 N+1 Case

Following the induction hypothesis it is assumed that the case where  $|I| + |J| = n = N$ ,  $S$  reaches the resolved state, and so to complete the proof it is shown what happens when  $n = N + 1$ .

So assuming by induction hypothesis that for all  $n' < n$ ,  $S$  reaches a resolved state. Then it can be shown that for  $n$  the network  $S$  can also reach a resolved state. To perform the proof, due the network topology, there are the following two subcases:

1. Induction in the size of  $|J|$ , when  $|I| = 1$ . The case  $|J| = 1$  is the same as the base case, so the case  $|J| > 1$  needs to be proved by induction hypothesis;
2. Induction in the size of  $|I|$ , when  $|J| > 1$ . This is only possible after the first sub-case has been proved.

### C.2.1 Induction in $|J|$

In here is performed the induction in the size of  $|J|$  and as stated before the case  $|J| = 1$  is the same as the base case, so by induction hypothesis it is assumed that when  $|J| = N$  the network  $S$  reaches a resolved state and in the following it is shown that the network  $S$  also resolves when  $|J| = N + 1$ .

In this case the channel capacity is never reached at any of the locations because there is only one Sensing Node (SN), and even in the case where the number of Relay Nodes (RNs) tend to infinity the channel capacity is never reached, since there is still only one SN. This is will be made clear along the following sequence of reductions.

The  $S$  structure in this case is defined as,

$$S \equiv \underbrace{(\nu\vec{c}\vec{c}) \left( sl_1 \bowtie rl_1 \mid \prod_{j \in J} cl \bowtie rl_j \right)}_{S^I} \mid SN \mid \prod_{j \in J} RN_j \mid CN$$

Note that  $sl_1 \bowtie rl_1$  was chosen to ease the readability of the proof. The  $sl_1$  can of course be connected to any other  $rl_j$ .

So first are computed the steps from the initial state until the resolved state.

$$S^I \mid SN \mid \underbrace{\prod_{j \in J} RN_j}_{S^{II}} \mid CN \equiv$$

$$S^{II} \mid CN \equiv$$

$$S^{II} \mid \underbrace{(\nu n_{CN}) * \left( \prod_{m \in M} Q_m \mid T \right)}_{CN} \mid R \longrightarrow$$

$$S^{II} \mid \left( \prod_{m \in M} Q_m \mid T \right) \mid \underbrace{(\nu n_{CN}) * \left( \prod_{m \in M} Q_m \mid T \right)}_{CN} \mid R \equiv$$

$$S^{II} \mid \left( \prod_{m \in M} Q_m \mid T \right) \mid CN \equiv$$

$$S^{II} \mid \left( \prod_{m \in M} Q_{m1} \mid Q_{m2} \mid Q_{m3} + Q_{m4} \mid T \right) \mid CN \longrightarrow$$

$$S^{II} \mid \left( \prod_{m \in M} \underbrace{Q_{4m}}_{\text{No SN reports available}} \mid T \right) \mid CN \equiv$$

$$S^{II} \mid \left( \prod_{m \in M} \bar{h}\langle KBU(\square) \rangle \mid T \right) \mid CN \equiv$$

$$S^{II} \mid \left( \prod_{m \in M} \bar{h}\langle KBU(\square) \rangle \mid T_1 \mid T_2 \right) \mid CN \equiv$$

$$S^{II} \mid \left( \prod_{m \in M} \bar{h}\langle KBU(\square) \rangle \mid (C_{KBU}(\square)) \mid T_2 \right) \mid CN \equiv$$

$$S^{II} \mid \left( \prod_{m \in M} \underbrace{\bar{h}\langle KBU(\square) \rangle}_{kbm} \mid h(b).C_{KBU}(b, y_1 :: y_M) + \right. \\ \left. \bar{k}\langle y_1 :: y_M \rangle \mid T_2 \right) \mid CN \longrightarrow$$

$$S^{II} \mid \bar{k}\langle kbm_1 :: kbm_m \rangle \mid T_2 \mid CN \equiv$$

$$S^{II} \mid \bar{k}\langle kbm_1 :: kbm_m \rangle \mid k(e).\bar{c}\langle (n_{CN}, NS(e)) \rangle \mid CN \longrightarrow$$

$$S^{II} \mid \bar{c}\langle (n_{CN}, NS(kbm_1 :: kbm_m)) \rangle \mid CN \equiv$$

$$\underbrace{S^{II} \mid \bar{c}\langle (n_{CN}, NS(kbm_1 :: kbm_m)) \rangle \mid CN}_{\text{Resolved State}}$$

So the resolved state is reached and from here on the network is initialized. The purpose of this proof is to show that the network reaches the same resolved state after a given number of iterations, as stated in the theorem.

$$S^{II} \mid \overline{cc}\langle(n_{CN}, \underbrace{NS(kbu_1 :: kbu_m)}_{ns})\rangle \mid CN \equiv$$

$$S^I \mid SN \mid \prod_{j \in J} RN_j \mid \overline{cc}\langle(n_{CN}, ns)\rangle \mid CN \equiv$$

$$S^I \mid SN \mid RN_1 \mid \prod_{j \in J, j \neq 1} RN_j \mid \overline{cc}\langle(n_{CN}, ns)\rangle \mid CN \equiv$$

$$\underbrace{S^I \mid \prod_{j \in J, j \neq 1} RN_j \mid SN \mid RN_1 \mid \overline{cc}\langle(n_{CN}, ns)\rangle \mid CN}_{S^{III}} \equiv$$

$$S^{III} \mid RN_1 \mid \overline{cc}\langle(n_{CN}, ns)\rangle \mid CN \equiv$$

$$S^{III} \mid \underbrace{(\nu n_{RN}) * RC}_{RN_1} \mid R_{RN} \mid \overline{cc}\langle(n_{CN}, ns)\rangle \mid CN \longrightarrow$$

$$S^{III} \mid RN_1 \mid RC \mid \overline{cc}\langle(n_{CN}, ns)\rangle \mid CN \equiv$$

$$S^{III} \mid RN_1 \mid R_1 \mid R_2 \mid \overline{cc}\langle(n_{CN}, ns)\rangle \mid CN \equiv$$

$$S^{III} \mid RN_1 \mid CP([], [], f) \mid R_2 \mid \overline{cc}\langle(n_{CN}, ns)\rangle \mid CN \equiv$$

$$S^{III} \mid RN_1 \mid cc(\lambda(x, y)(x, y)).CP(x_1 :: l_1, y_1 :: l_2; f) + \overline{f}\langle(l_1, l_2)\rangle \mid R_2 \mid \overline{cc}\langle(n_{CN}, ns)\rangle \mid CN \longrightarrow$$

$$S^{III} \mid RN_1 \mid \overline{f}\langle(n_{CN}, ns)\rangle \mid R_2 \mid CN \equiv$$

$$S^{III} \mid RN_1 \mid \overline{f}\langle(n_{CN}, ns)\rangle \mid f(a, i). \overline{cc}\langle(a, i)\rangle \mid CN \longrightarrow$$

$$S^{III} | RN_1 | \bar{c}\bar{c}\langle(n_{CN}, ns)\rangle | CN \longrightarrow$$

$$S^I | \prod_{j \in J, j \neq 1} RN_j | SN | RN_1 | \bar{c}\bar{c}\langle(n_{CN}, ns)\rangle | CN \equiv$$

$$S^I | \underbrace{\prod_{j \in J, j \neq 1} RN_j}_{S^{IV}} | RN_1 | SN | \bar{c}\bar{c}\langle(n_{CN}, ns)\rangle | CN \equiv$$

$$S^{IV} | SN | \bar{c}\bar{c}\langle(n_{CN}, ns)\rangle | CN \equiv$$

$$S^{IV} | \underbrace{(\nu n_{SN}) * P}_{SN} | R_{SN} | \bar{c}\bar{c}\langle(n_{CN}, ns)\rangle | CN \longrightarrow$$

$$S^{IV} | SN | P | \bar{c}\bar{c}\langle(n_{CN}, ns)\rangle | CN \equiv$$

$$S^{IV} | SN | P_1 | P_2 | P_3 | \bar{c}\bar{c}\langle(n_{CN}, ns)\rangle | CN \equiv$$

$$S^{IV} | SN | cc(\lambda(x, y)(x, y)) \text{ if } x = n_{CN} \text{ then} \\ \bar{e}\langle y \rangle | P_2 | P_3 | \bar{c}\bar{c}\langle(n_{CN}, ns)\rangle | CN \longrightarrow$$

$$S^{IV} | SN | \bar{e}\langle ns \rangle | P_2 | P_3 | CN \equiv$$

$$S^{IV} | SN | \bar{e}\langle ns \rangle | e(a).\bar{f}\langle SS(a) \rangle | P_3 | CN \longrightarrow$$

$$S^{IV} | SN | \underbrace{\bar{f}\langle SS(ns) \rangle}_{ss} | P_3 | CN \equiv$$

$$S^{IV} | SN | \bar{f}\langle ss \rangle | P_3 | CN \equiv$$

$$S^{IV} | SN | \bar{f}\langle ss \rangle | f(b).\bar{c}\bar{c}\langle n_{SN}, b \rangle | CN \longrightarrow$$

$$S^{IV} | SN | \bar{c}\bar{c}\langle n_{SN}, ss \rangle | CN \equiv$$

$$S^I \mid \prod_{j \in J, j \neq 1} RN_j \mid RN_1 \mid SN \mid \overline{cc}\langle n_{SN}, ss \rangle \mid CN \equiv$$

$$S^I \mid \prod_{j \in J, j \neq 1} RN_j \mid \underbrace{(\nu n_{RN}) * RC \mid R_{RN}}_{RN_1} \mid SN \mid \overline{cc}\langle n_{SN}, ss \rangle \mid CN \longrightarrow$$

$$S^I \mid \prod_{j \in J, j \neq 1} RN_j \mid RC \mid RN_1 \mid SN \mid \overline{cc}\langle n_{SN}, ss \rangle \mid CN \equiv$$

$$\underbrace{S^I \mid \prod_{j \in J, j \neq 1} RN_j \mid RN_1 \mid SN \mid RC \mid \overline{cc}\langle n_{SN}, ss \rangle \mid CN}_{S^V} \equiv$$

$$S^V \mid RC \mid \overline{cc}\langle n_{SN}, ss \rangle \mid CN \equiv$$

$$S^V \mid R_1 \mid R_2 \mid \overline{cc}\langle n_{SN}, ss \rangle \mid CN \equiv$$

$$S^V \mid CP(\square, \square; f) \mid R_2 \mid \overline{cc}\langle n_{SN}, ss \rangle \mid CN \equiv$$

$$S^V \mid cc(\lambda(x, y)(x, y)).CP(x :: l_1, y :: l_2; f) + \overline{f}\langle l_1, l_2 \rangle \mid R_2 \mid \overline{cc}\langle n_{SN}, ss \rangle \mid CN \longrightarrow$$

$$S^V \mid \overline{f}\langle n_{SN}, ss \rangle \mid R_2 \mid CN \equiv$$

$$S^V \mid \overline{f}\langle n_{SN}, ss \rangle \mid f(a, i).\overline{cc}\langle (a, i) \rangle \mid CN \longrightarrow$$

$$S^V \mid \overline{cc}\langle (n_{SN}, ss) \rangle \mid CN \equiv$$

$$S^V \mid \overline{cc}\langle (n_{SN}, ss) \rangle \mid \underbrace{(\nu n_{CN}) * \left( \prod_{m \in M} Q_m \mid T \right)}_{CN} \mid R_{CN} \equiv$$



$$S^V \mid \overline{cc}\langle(n_{SN}, ss)\rangle \mid \prod_{m \in M} (Q_{m1} \mid Q_{m2} \mid Q_{m3} + Q_{m4}) \mid T \mid CN \longrightarrow$$

$$S^V \mid \overline{cc}\langle(n_{SN}, ss)\rangle \mid \prod_{m \in M} (Q_{m1} \mid Q_{m2} \mid Q_{m3}) \mid T \mid CN \equiv$$

$$S^V \mid \overline{cc}\langle(n_{SN}, ss)\rangle \mid \prod_{m \in M} (cc(\lambda(x, y)(x, y)) \text{ if } x \neq n_{CN} \text{ then } C_m(y :: l) \\ + \overline{d_m}\langle l \rangle \mid Q_{m2} \mid Q_{m3}) \mid T \mid CN \longrightarrow$$

$$S^V \mid \prod_{m \in M} (\overline{d_m}\langle ss \rangle \mid Q_{m2} \mid Q_{m3}) \mid T \mid CN \equiv$$

$$S^V \mid \prod_{m \in M} (\overline{d_m}\langle ss \rangle \mid d_m(e).\overline{g_m}\langle LDDF(e) \rangle \mid Q_{m3}) \mid T \mid CN \longrightarrow$$

$$S^V \mid \prod_{m \in M} (\overline{g_m}\langle LDDF(ss) \rangle \mid Q_{m3}) \mid T \mid CN \equiv$$

$$S^V \mid \prod_{m \in M} (\overline{g_m}\langle LDDF(ss) \rangle \mid g_m(i).\overline{h}\langle KBU(i) \rangle) \mid T \mid CN \longrightarrow$$

$$S^V \mid \prod_{m \in M} (\overline{h}\langle \underbrace{KBU(LDDF(ss))}_{kbu_m} \rangle) \mid T \mid CN \equiv$$

$$S^V \mid \prod_{m \in M} \overline{h}\langle kbu_m \rangle \mid T \mid CN \equiv$$

$$S^V \mid \prod_{m \in M} \overline{h}\langle kbu_m \rangle \mid T_1 \mid T_2 \mid CN \equiv$$

$$S^V \mid \prod_{m \in M} \overline{h}\langle kbu_m \rangle \mid C_{KBU}(\square) \mid T_2 \mid CN \equiv$$

$$\begin{aligned}
S^V &| \prod_{m \in M} \bar{h}\langle kb u_m \rangle | h(b).C_{KBU}(b :: l) + \bar{k}\langle l \rangle | T_2 | CN \longrightarrow \\
S^V &| \bar{k}\langle (kb u_1 :: kb u_m) \rangle | T_2 | CN \equiv \\
S^V &| \bar{k}\langle (kb u_1 :: kb u_m) \rangle | k(e).\bar{c}\bar{c}\langle (n_{CN}, NS(e)) \rangle | CN \longrightarrow \\
\underbrace{S^V &| \bar{c}\bar{c}\langle (n_{CN}, NS(kb u_1 :: kb u_m)) \rangle | CN}_{\text{Resolved State}}
\end{aligned}$$

The network reaches the resolved state, as proved by induction in the size of  $|J|$ . When the size of  $|J|$  varies the capacity of the channel is never reached, since it only depends on the number of Sensing Nodes (SNs).

### C.2.2 Induction in $|I|$

After proving that the network reaches the resolved state periodically independently of the size of  $|J|$ , then it is finally possible to prove that the network reaches the resolved state also independently of the size of  $|I|$ . For that it is assumed that by induction hypothesis the network reaches a resolved state when  $|I| = N$  and then it can be shown that the network still resolves for  $|I| = N + 1$ . This proof is performed while considering that  $|J| > 1$ .

As stated in the proof by induction in the size of  $|J|$  the channel capacity is only reached when the number of SNs is above a certain threshold. Therefore this part of the proof is divided in three parts, the case where the channel capacity is not overcome at any location, the case where the channel capacity is overcome at the  $RN_j$  location and the case where the capacity is overcome at the  $CN$  location.

Since the differences between each one is only at instance where the  $RN$  receives data from the  $SN$ s and when the  $CN$  receives messages from the  $RN$ s then at those point in the reduction sequence, we will show what would happen in each case. This will allow to simplify the proof and make it less cumbersome to follow.

The  $S$  structure in this case is defined as,

$$S \equiv (\nu \bar{c}\bar{c}) \underbrace{\left( \prod_{j \in J} cl \bowtie rl_j \mid \prod_{j \in J} \prod_{i \in I_j} sl_i \bowtie rl_i \right)}_{S^I} \mid \prod_{j \in J} RN_j \mid \prod_{i \in \bigcup_{j \in J} I_j} SN_i \mid CN \equiv$$

$$S^I \mid \prod_{j \in J, j \neq l} RN_j \mid RN_l \mid \prod_{i \in \bigcup_{j \in J} I_j, i \neq k} SN_i \mid SN_k \mid CN \equiv$$

$$\underbrace{S^I \mid \prod_{j \in J, j \neq l} RN_j \mid \prod_{i \in \bigcup_{j \in J} I_j, i \neq k} SN_i \mid RN_l \mid SN_k \mid CN}_{S^{II}} \equiv$$

$$S^{II} \mid RN_l \mid SN_k \mid CN \equiv$$

From this step we can compute the sequence of reductions which will allow the network to reach the resolved state.

$$\underbrace{S^{II} \mid RN_l \mid SN_k \mid CN}_{S^{III}} \equiv$$

$$S^{III} \mid CN \equiv$$

$$S^{III} \mid \underbrace{(\nu n_{CN}) * \left( \prod_{m \in M} Q_m \mid T \right)}_{CN} \mid R \longrightarrow$$

$$S^{III} \mid \left( \prod_{m \in M} Q_m \mid T \right) \mid \underbrace{(\nu n_{CN}) * \left( \prod_{m \in M} Q_m \mid T \right)}_{CN} \mid R \equiv$$

$$S^{III} \mid \left( \prod_{m \in M} Q_m \mid T \right) \mid CN \equiv$$

$$S^{III} \mid \left( \prod_{m \in M} Q_{m1} \mid Q_{m2} \mid Q_{m3} + Q_{m4} \mid T \right) \mid CN \longrightarrow$$

$$S^{III} \mid \left( \prod_{m \in M} \underbrace{Q_{4m}}_{\text{No SN reports available}} \mid T \right) \mid CN \equiv$$

$$S^{III} \mid \left( \prod_{m \in M} \bar{h} \langle \underbrace{KBU(\square)}_{kbu_m} \rangle \mid T \right) \mid CN \equiv$$

$$S^{III} \mid \left( \prod_{m \in M} \bar{h} \langle kbu_m \rangle \mid T \right) \mid CN \equiv$$

$$S^{III} \mid \left( \prod_{m \in M} \bar{h} \langle kbu_m \rangle \mid T_1 \mid T_2 \right) \mid CN \equiv$$

$$S^{III} \mid \left( \prod_{m \in M} \bar{h} \langle kbu_m \rangle \mid C_{KBU}(\square) \mid T_2 \right) \mid CN \equiv$$

$$S^{III} \mid \left( \prod_{m \in M} \bar{h} \langle kbu_m \rangle \mid h(b).C_{KBU}(b :: l) + \bar{k}(l) \mid T_2 \right) \mid CN \longrightarrow$$

$$S^{III} \mid \bar{k} \langle kbu_1 :: kbu_M \rangle \mid T_2 \mid CN \equiv$$

$$S^{III} \mid \bar{k} \langle kbu_1 :: kbu_M \rangle \mid k(e).\bar{c}c \langle (n_{CN}, NS(e)) \rangle \mid CN \longrightarrow$$

$$S^{III} \mid \bar{c}c \langle (n_{CN}, NS(kbu_1 :: kbu_M)) \rangle \mid CN \equiv$$

$$\underbrace{S^{III} \mid \bar{c}c \langle (n_{CN}, NS(kbu_1 :: kbu_M)) \rangle \mid CN}_{\text{Resolved State}}$$

So the resolved state is reached and from here on the network is initialized. In the rest of the proof it will be shown that after a number of sequence of reductions the network reaches the same resolved state as state in the theorem. Note that emphasis will be given in the reduction sequences where the effect of the channel capacity takes place.

$$S^{III} \mid \bar{c}c \langle (n_{CN}, \underbrace{NS(kbu_1 :: kbu_M)}_{ns}) \rangle \mid CN \equiv$$

$$S^{III} \mid \overline{cc}\langle(n_{CN}, ns)\rangle \mid CN \equiv$$

$$S^{II} \mid SN_k \mid RN_l \mid \overline{cc}\langle(n_{CN}, ns)\rangle \mid CN \equiv$$

The message broadcasted from the Central Node (CN) is received by all the RNs, to ease the demonstration it is only shown what happens in one of the RNs, but it should be noted that the same process is occurring in all the RNs.

$$S^{II} \mid SN_k \mid \underbrace{(\nu n_{RN}) * RC \mid R_{RN}}_{RN_l} \mid \overline{cc}\langle(n_{CN}, ns)\rangle \mid CN \longrightarrow$$

$$S^{II} \mid SN_k \mid RN_l \mid RC \mid \overline{cc}\langle(n_{CN}, ns)\rangle \mid CN \equiv$$

$$S^{II} \mid SN_k \mid RN_l \mid R_1 \mid R_2 \mid \overline{cc}\langle(n_{CN}, ns)\rangle \mid CN \equiv$$

$$S^{II} \mid SN_k \mid RN_l \mid CP([], [], f) \mid R_2 \mid \overline{cc}\langle(n_{CN}, ns)\rangle \mid CN \equiv$$

$$S^{II} \mid SN_k \mid RN_l \mid cc(\lambda(x, y)(x, y)).CP(x :: l_1, y :: l_2; f) + \overline{f}\langle l_1, l_2 \rangle \mid R_2 \mid \overline{cc}\langle(n_{CN}, ns)\rangle \mid CN \longrightarrow$$

$$S^{II} \mid SN_k \mid RN_l \mid \overline{f}\langle n_{CN}, ns \rangle \mid R_2 \mid CN \equiv$$

$$S^{II} \mid SN_k \mid RN_l \mid \overline{f}\langle n_{CN}, ns \rangle \mid f(a, i). \overline{cc}\langle(a, i)\rangle \mid CN \longrightarrow$$

$$S^{II} \mid SN_k \mid RN_l \mid \overline{cc}\langle(n_{CN}, ns)\rangle \mid CN \equiv$$

$$S^{II} \mid RN_l \mid CN \mid \underbrace{(\nu n_{SN_k}) * P \mid R_{SN}}_{SN_k} \mid \overline{cc}\langle(n_{CN}, ns)\rangle \longrightarrow$$

$$\underbrace{S^{II} \mid RN_l \mid CN \mid SN_k \mid P}_{S^{IV}} \mid \overline{cc}\langle(n_{CN}, ns)\rangle \equiv$$

$$S^{IV} \mid P_1 \mid P_2 \mid P_3 \mid \overline{cc}\langle(n_{CN}, ns)\rangle \equiv$$

$$S^{IV} \mid cc(\lambda(x, y)(x, y)) \text{ if } x = n_{CN} \text{ then } \bar{e}\langle y \rangle \mid P_2 \mid P_3 \mid \\ \bar{cc}\langle (n_{CN}, ns) \rangle \longrightarrow$$

$$S^{IV} \mid \bar{e}\langle ns \rangle \mid P_2 \mid P_3 \equiv$$

$$S^{IV} \mid \bar{e}\langle ns \rangle \mid e(a).\bar{f}\langle SS(a) \rangle \mid P_3 \longrightarrow$$

$$S^{IV} \mid \bar{f}\langle SS(ns) \rangle \mid P_3 \equiv$$

$$S^{IV} \mid \underbrace{\bar{f}\langle SS(ns) \rangle}_{ss_k} \mid f(b).\bar{cc}\langle (n_{SN_k}, b) \rangle \longrightarrow$$

$$S^{IV} \mid \bar{cc}\langle (n_{SN_k}, ss_k) \rangle \equiv$$

$$S^{II} \mid CN \mid SN_k \mid RN_l \mid \bar{cc}\langle (n_{SN_k}, ss_k) \rangle \equiv$$

$$S^{II} \mid CN \mid SN_k \mid \underbrace{(\nu n_{RN}) * RC \mid R_{RN}}_{RN_l} \mid \bar{cc}\langle (n_{SN_k}, ss_k) \rangle \longrightarrow$$

$$S^{II} \mid CN \mid SN_k \mid RN_l \mid RC \mid \bar{cc}\langle (n_{SN_k}, ss_k) \rangle \equiv$$

So after the sequence of reductions it is reached the step where the capacity of the channel might be overcome. To ease the exposition of the proof it is only shown what happens to the SNs associated with  $RN_l$ .

$$S^I \mid \prod_{j \in J, j \neq l} RN_j \mid \prod_{i \in \bigcup_{j \in J} I_j, i \neq k} (SN_i \mid \bar{cc}\langle (n_{SN_i}, ss_i) \rangle) \\ \mid SN_k \mid \bar{cc}\langle (n_{SN_k}, ss_k) \rangle \mid CN \mid RN_l \mid RC \equiv$$

$$S^I \mid \prod_{j \in J, j \neq l} RN_j \mid \prod_{i \in \bigcup_{j \in J, j \neq l} I_j} (SN_i \mid \bar{cc}\langle (n_{SN_i}, ss_i) \rangle) \\ \mid \prod_{h \in I_l, h \neq k} (SN_h \mid \bar{cc}\langle (n_{SN_h}, ss_h) \rangle) \\ \mid SN_k \mid \bar{cc}\langle (n_{SN_k}, ss_k) \rangle \mid CN \mid RN_l \mid RC \equiv$$

Consider that at the location of the  $RN_l$  the capacity of the  $cc$  is given by  $b(cc, rn_l)$ . If the size of  $|I_l|$  is lower than  $b(cc, rn_l)$  then the capacity of the channel is not reached and therefore none of the messages from the  $SNs$  are dropped. When the size of  $|I_l|$  is higher than  $b(cc, rn_l)$  some of the messages are dropped. The first case follows the same sequence of reductions as the base case, so here it is shown only what happens in the second case, i.e. when some of the messages are dropped, according the R-DROP rule. For that is considered  $I_l = I_l^d \cup I_l^{nd}$ , where  $I_l^d$  is the set of  $SNs$  with dropped messages and  $I_l^{nd}$  is the set of  $SNs$  which their messages are not dropped and that  $k \in I_l^{nd}$ . So first is shown the reduction sequence where the messages are dropped. Note that messages directed to other RNs are also exchanged, although they are not shown explicitly here.

$$\begin{aligned}
& S^I \mid \prod_{j \in J, j \neq l} RN_j \mid \prod_{i \in \bigcup_{j \in J, j \neq l} I_j} (SN_i \mid \overline{cc}\langle(n_{SN_i}, ss_i)\rangle) \\
& \mid \prod_{h \in I_l^d} (SN_h \mid \overline{cc}\langle(n_{SN_h}, ss_h)\rangle) \mid \prod_{h \in I_l^{nd}, h \neq k} (SN_h \mid \overline{cc}\langle(n_{SN_h}, ss_h)\rangle) \\
& \mid SN_k \mid \overline{cc}\langle(n_{SN_k}, ss_k)\rangle \mid CN \mid RN_l \mid RC \longrightarrow^+
\end{aligned}$$

$$\begin{aligned}
& S^I \mid \prod_{j \in J, j \neq l} RN_j \mid \prod_{i \in \bigcup_{j \in J, j \neq l} I_j} SN_i \\
& \mid \prod_{h \in I_l^d} SN_h \mid \prod_{h \in I_l^{nd}, h \neq k} (SN_h \mid \overline{cc}\langle(n_{SN_h}, ss_h)\rangle) \\
& \mid SN_k \mid \overline{cc}\langle(n_{SN_k}, ss_k)\rangle \mid CN \mid RN_l \mid RC \equiv
\end{aligned}$$

So from here the normal reduction sequence continues, which coincides with the case where the  $|I_l|$  is lower than  $b(cc, rn_l)$ .

$$\begin{aligned}
& S^I \mid \prod_{j \in J, j \neq l} RN_j \mid \prod_{i \in \bigcup_{j \in J, j \neq l} I_j} SN_i \\
& \mid \prod_{h \in I_l^d} SN_h \mid \prod_{h \in I_l^{nd}, h \neq k} (SN_h \mid \overline{cc}\langle(n_{SN_h}, ss_h)\rangle) \\
& \mid SN_k \mid \overline{cc}\langle(n_{SN_k}, ss_k)\rangle \mid CN \mid RN_l \mid R_1 \mid R_2 \equiv
\end{aligned}$$

$$\begin{aligned}
& S^I \mid \prod_{j \in J, j \neq l} RN_j \mid \prod_{i \in \bigcup_{j \in J, j \neq l} I_j} SN_i \mid \prod_{h \in I_l^d} SN_h \mid \prod_{h \in I_l^{nd}, h \neq k} (SN_h \mid \overline{cc}\langle(n_{SN_h}, ss_h)\rangle) \\
& \mid SN_k \mid \overline{cc}\langle(n_{SN_k}, ss_k)\rangle \mid CN \mid RN_l \mid \\
& cc(\lambda(x, y)(x, y)).CP(x :: l_1, y :: l_2; f) + \bar{f}\langle l_1, l_2 \rangle \mid R_2 \longrightarrow^+
\end{aligned}$$

$$S^I \mid \prod_{j \in J, j \neq l} RN_j \mid \prod_{i \in \cup_{j \in J, j \neq l} I_j} SN_i \mid \prod_{h \in I_l^d} SN_h \mid \prod_{h \in I_l^{nd}, h \neq k} SN_h \\ \mid SN_k \mid CN \mid RN_l \mid \bar{f} \langle \underbrace{n_{SN_h} :: n_{SN_k}}_{x_l}, \underbrace{ss_h :: ss_k}_{y_l} \rangle \mid R_2 \equiv$$

$$S^I \mid \prod_{j \in J, j \neq l} RN_j \mid \prod_{i \in \cup_{j \in J, j \neq l} I_j} SN_i \mid \prod_{h \in I_l^d} SN_h \mid \prod_{h \in I_l^{nd}, h \neq k} SN_h \\ \mid SN_k \mid CN \mid RN_l \mid \bar{f} \langle x_l, y_l \rangle \mid R_2 \equiv$$

$$S^I \mid \prod_{j \in J, j \neq l} RN_j \mid \prod_{i \in \cup_{j \in J, j \neq l} I_j} SN_i \mid \prod_{h \in I_l^d} SN_h \mid \prod_{h \in I_l^{nd}, h \neq k} SN_h \\ \mid SN_k \mid CN \mid RN_l \mid \bar{f} \langle x_l, y_l \rangle \mid f(a, i) \cdot \bar{cc} \langle (a, i) \rangle \longrightarrow$$

$$S^I \mid \prod_{j \in J, j \neq l} RN_j \mid \prod_{i \in \cup_{j \in J, j \neq l} I_j} SN_i \mid \prod_{h \in I_l^d} SN_h \mid \prod_{h \in I_l^{nd}, h \neq k} SN_h \\ \mid SN_k \mid CN \mid RN_l \mid \bar{cc} \langle (x_l, y_l) \rangle \longrightarrow$$

$$S^I \mid \prod_{j \in J, j \neq l} RN_j \mid RN_l \mid \bar{cc} \langle (x_l, y_l) \rangle \mid \prod_{i \in \cup_{j \in J} I_j, i \neq k} SN_i \mid SN_k \mid CN \equiv$$

At this point in the sequence of reductions it is reached the second step where the capacity of the channel might be overcome. At this step the RNs are going to send the concatenated messages that they received from their respective SNs. The same will occur as in the previous step, i.e. some of these messages will be dropped. In the following it is shown only the case where some of the messages need to be dropped. Following the same reasoning as before, the RNs are divided into two groups, the one where the messages will be dropped and the one where the messages will not. Therefore  $J = J^d \cup J^{nd}$ , where  $J^d$  is the set of RNs where the message is dropped and  $J^{nd}$  the set of RNs where the message is not dropped and  $l \in J^{nd}$ .

$$S^I \mid \prod_{j \in J^d} RN_j \mid \bar{cc} \langle (x_j, y_j) \rangle \mid \prod_{j \in J^{nd}, j \neq l} RN_j \mid \bar{cc} \langle (x_j, y_j) \rangle \mid RN_l \mid \bar{cc} \langle (x_l, y_l) \rangle \\ \mid \prod_{i \in \cup_{j \in J} I_j, i \neq k} SN_i \mid SN_k \mid CN \longrightarrow^+$$



$$\begin{aligned}
& S^I \mid \prod_{j \in J^d} RN_j \mid \prod_{j \in J^{nd}, j \neq l} RN_j \mid \overline{cc}\langle(x_j, y_j)\rangle \mid RN_l \mid \overline{cc}\langle(x_l, y_l)\rangle \\
& \quad \mid \prod_{i \in \cup_{j \in J} I_j, i \neq k} SN_i \mid SN_k \mid CN \equiv \\
& S^I \mid \prod_{j \in J^d} RN_j \mid \prod_{j \in J^{nd}, j \neq l} RN_j \mid \overline{cc}\langle(x_j, y_j)\rangle \mid RN_l \mid \overline{cc}\langle(x_l, y_l)\rangle \\
& \mid \prod_{i \in \cup_{j \in J} I_j, i \neq k} SN_i \mid SN_k \mid \underbrace{(\nu n_{CN}) * \left( \prod_{m \in M} Q_m \mid T \right)}_{CN} \mid R_{CN} \longrightarrow \\
& S^I \mid \prod_{j \in J^d} RN_j \mid \prod_{j \in J^{nd}, j \neq l} RN_j \mid \overline{cc}\langle(x_j, y_j)\rangle \mid RN_l \mid \overline{cc}\langle(x_l, y_l)\rangle \\
& \quad \mid \prod_{i \in \cup_{j \in J} I_j, i \neq k} SN_i \mid SN_k \mid CN \mid \prod_{m \in M} Q_m \mid T \equiv \\
& S^I \mid \prod_{j \in J^d} RN_j \mid \prod_{j \in J^{nd}, j \neq l} RN_j \mid \overline{cc}\langle(x_j, y_j)\rangle \mid RN_l \mid \overline{cc}\langle(x_l, y_l)\rangle \\
& \quad \mid \prod_{i \in \cup_{j \in J} I_j, i \neq k} SN_i \mid SN_k \mid CN \\
& \quad \mid \left( \prod_{m \in M} Q_{m1} \mid Q_{m2} \mid Q_{m3} + Q_{m4} \right) \mid T \longrightarrow \\
& S^I \mid \prod_{j \in J^d} RN_j \mid \prod_{j \in J^{nd}, j \neq l} RN_j \mid \overline{cc}\langle(x_j, y_j)\rangle \mid RN_l \mid \overline{cc}\langle(x_l, y_l)\rangle \\
& \quad \mid \prod_{i \in \cup_{j \in J} I_j, i \neq k} SN_i \mid SN_k \mid CN \mid \\
& \quad \left( \prod_{m \in M} cc(\lambda(x, y)(x, y)) \text{ if } x \neq n_{CN} \text{ then } C_m(y :: l) + \right. \\
& \quad \quad \left. \overline{d}_m\langle l \rangle \mid Q_{m2} \mid Q_{m3} \right) \mid T \longrightarrow \\
& \underbrace{S^I \mid \prod_{j \in J^d} RN_j \mid \prod_{j \in J^{nd}, j \neq l} RN_j \mid RN_l \mid \prod_{i \in \cup_{j \in J} I_j, i \neq k} SN_i \mid SN_k \mid CN}_{SV} \\
& \quad \mid \left( \prod_{m \in M} \overline{d}_m\langle \underbrace{(y_1, \dots, y_k)}_{ssm} \rangle \mid Q_{m2} \mid Q_{m3} \right) \mid T \equiv
\end{aligned}$$

$$\begin{aligned}
S^V &| \left( \prod_{m \in M} \overline{d}_m \langle ss_m \rangle \mid Q_{m2} \mid Q_{m3} \right) \mid T \equiv \\
S^V &| \left( \prod_{m \in M} \overline{d}_m \langle ss_m \rangle \mid d(e) \cdot \overline{g}_m \langle LDDF(e) \rangle \mid Q_{m3} \right) \mid T \longrightarrow \\
S^V &| \left( \prod_{m \in M} \overline{g}_m \langle LDDF(ss_m) \rangle \mid Q_{m3} \right) \mid T \longrightarrow \\
S^V &| \left( \prod_{m \in M} \overline{g}_m \langle LDDF(ss_m) \rangle \mid g_m(i) \cdot \overline{h} \langle KBU(i) \rangle \right) \mid T \longrightarrow \\
S^V &| \left( \prod_{m \in M} \overline{h} \langle \underbrace{KBU(LDDF(ss_m))}_{kb_{u_m}} \rangle \right) \mid T \equiv \\
S^V &| \prod_{m \in M} \overline{h} \langle kb_{u_m} \rangle \mid T \equiv \\
S^V &| \prod_{m \in M} \overline{h} \langle kb_{u_m} \rangle \mid T_1 \mid T_2 \equiv \\
S^V &| \prod_{m \in M} \overline{h} \langle kb_{u_m} \rangle \mid C_{KBU}(\square) \mid T_2 \equiv \\
S^V &| \prod_{m \in M} \overline{h} \langle kb_{u_m} \rangle \mid h(b) \cdot C_{KBU}(b :: l) + \overline{k} \langle l \rangle \mid T_2 \equiv \\
S^V &| \prod_{m \in M} \overline{k} \langle kb_{u_1} :: kb_{u_M} \rangle \mid T_2 \equiv \\
S^V &| \prod_{m \in M} \overline{k} \langle kb_{u_1} :: kb_{u_M} \rangle \mid k(e) \cdot \overline{c} \langle (n_{CN}, NS(e)) \rangle \longrightarrow \\
S^V &| \underbrace{\prod_{m \in M} \overline{c} \langle (n_{CN}, NS(kb_{u_1} :: kb_{u_M})) \rangle}_{\text{Resolved State}}
\end{aligned}$$

So the network  $S$  still reaches the resolved state, as stated in Theorem 5.

□



# D

## Appendix - Channel Duty Cycle Estimation

After a decision is reached in regards to the state of the channel after the data fusion, it is time to combine it with past observations. This will allow to obtain updated statistics of the state of the sensed channel, e.g. duty cycle, longest observed free period, etc. Through the use of these statistics, it is then possible for the Cognitive Radio Network (CRN) to reach an adequate decision on when to use a given channel for communications.

The purpose here is to estimate the  $m^{th}$  channel remainder of signal source duty cycle, also known as un-occupancy, denoted as  $s_m$ . For this estimation to be of use it needs to be updated continuously during the CRN lifetime. The issue is that sometimes there are no recent observations available for the  $m^{th}$  channel.

To get an estimation of  $s_m$ , two methods are considered, which are an exponential moving average and a linear moving average, respectively. Both are modified to include a reset mechanism which allows to update the  $s_m$ , although introducing an error, even when the channel was not sensed.

## D.1 Exponential Moving Average Estimator

The channel  $m$  un-occupancy,  $s_m$ , is estimated continuously during the network lifetime. This estimation is based on previous observations, when available, while taking in account when the channels have not been observed in a long time. The channel un-occupancy estimator, an exponential moving average with reset factor, is given by,

The exponential moving average with reset factor channel un-occupancy estimator is given by,

$$\hat{s}_m = \begin{cases} (1 - \alpha)\hat{s}_{m,old} + \alpha s_{m,inst} & ,\text{if } m \text{ sensed} \\ (1 - \alpha)\hat{s}_{m,old} + \alpha s_{reset} & ,\text{if } m \text{ not sensed} \end{cases} \quad (\text{D.1})$$

where  $\hat{s}_m$  is the estimated unoccupancy of the channel  $m$ ,  $\hat{s}_{m,old}$  is the estimated un-occupancy from the last scheduling bid,  $s_{m,inst}$  is the instantaneous occupancy obtained from the sensing of the channel  $m$  in the previous sensing session,  $s_{reset}$  is the term that is used to reset the channel un-occupancy estimation when the channel has not been sensed in the previous sensing session and finally  $\alpha$  the forgetting factor used to tune the exponential moving average. Through this scheme it is possible to estimate the channel un-occupancy and to have a feedback mechanism which enables a controlled distribution of the sensing nodes by using the  $\hat{s}_m$  as the channel bid, i.e.  $w_m$ .

### D.1.1 Linear Moving Average Estimator

The linear moving average with reset factor channel un-occupancy estimator is given by,

$$\hat{s}_m = \begin{cases} \frac{\sum_{i=1}^{OW} s_{m,old}^i + s_{m,inst}}{OW} & ,\text{if } m \text{ sensed} \\ \frac{\sum_{i=1}^{OW} s_{m,old}^i + s_{reset}}{OW} & ,\text{if } m \text{ not sensed} \end{cases} \quad (\text{D.2})$$

where  $\hat{s}_m$  is the estimated un-occupancy of the channel  $m$  is,  $s_{m,old}^i$  is the observed un-occupancy in the  $i^{th}$  previous spectrum sensing session,  $s_{m,inst}$  is the instantaneous occupancy obtained from the sensing of the channel  $m$  in the previous sensing session,  $s_{reset}$  is the term that is used to reset the channel un-occupancy estimation when the channel has not been sensed in the previous sensing session, and  $O_W$  is the observation window length.

### D.1.2 Implementation Issues and Performance Comparison

The linear estimator achieves the minimum  $RMSE$  if the observation window is the same as the number of observations, although needing to have all the previous observations stored. The exponential average can offer similar performance, depending on the distribution of the samples, but it only needs to store the previous estimation. Therefore from an implementation point of view the exponential estimator is the one to choose.

In Figure D.1 it is depicted the obtained  $RMSE$  while using both estimators for each of the channels. Two scenarios are considered, one where the channel is sensed each session, i.e. all samples are considered, and the case where the channel is sensed every second sensing session, i.e. half of the available samples are taken into account.  $s_{reset}$  was set to 0.5,  $\alpha$  was set to 0.01 and the  $OW$  was set to 40.

From Figure D.1 it can be observed, as expected, that both estimators have similar performance, except in the  $Ch2$  during the interrupted sensing, where the  $RMSE$  was substantially higher for the exponential estimator. This was caused by the  $s_{reset}$  value which was set as 0.5. Although it can be argued that by taking out the  $s_{reset}$  the  $RMSE$  would be minimized, it needs to be considered since the estimation is used as channel bid for the scheduler and therefore needs to be updated in every sensing cycle.

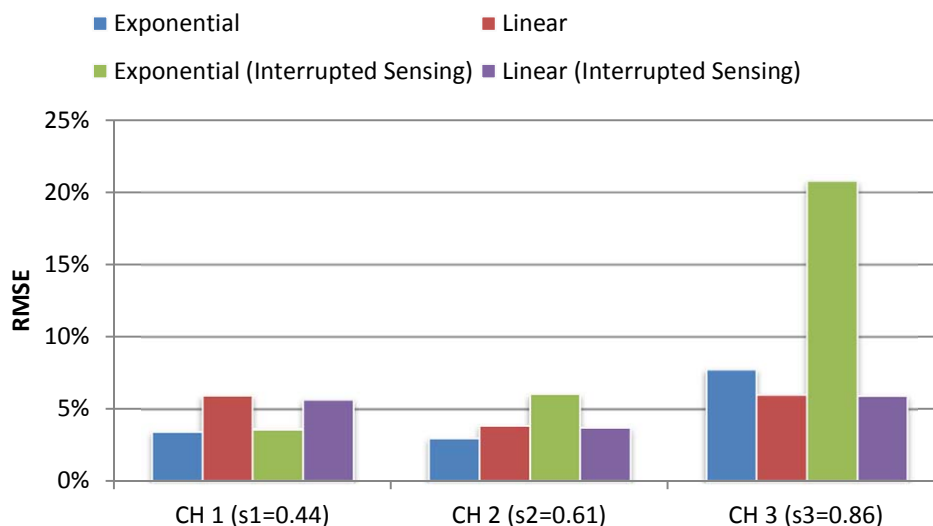

Figure D.1: Channel Estimation Performance Comparison