



AALBORG UNIVERSITY
DENMARK

Aalborg Universitet

Loss and Thermal Modeling of Metal Oxide Varistors (MOV) Under Standard Current Surge Mission Profile

Vernica, Ionut; Jensen, Per Thåstrup; Wang, Huai; Iannuzzo, Francesco; Otto, Susanne; Blaabjerg, Frede

Published in:
2019 IEEE Energy Conversion Congress and Exposition, ECCE 2019

DOI (link to publication from Publisher):
[10.1109/ECCE.2019.8913287](https://doi.org/10.1109/ECCE.2019.8913287)

Publication date:
2019

Document Version
Accepted author manuscript, peer reviewed version

[Link to publication from Aalborg University](#)

Citation for published version (APA):
Vernica, I., Jensen, P. T., Wang, H., Iannuzzo, F., Otto, S., & Blaabjerg, F. (2019). Loss and Thermal Modeling of Metal Oxide Varistors (MOV) Under Standard Current Surge Mission Profile. In *2019 IEEE Energy Conversion Congress and Exposition, ECCE 2019* (pp. 7113-7117). Article 8913287 IEEE Press. <https://doi.org/10.1109/ECCE.2019.8913287>

General rights

Copyright and moral rights for the publications made accessible in the public portal are retained by the authors and/or other copyright owners and it is a condition of accessing publications that users recognise and abide by the legal requirements associated with these rights.

- Users may download and print one copy of any publication from the public portal for the purpose of private study or research.
- You may not further distribute the material or use it for any profit-making activity or commercial gain
- You may freely distribute the URL identifying the publication in the public portal -

Take down policy

If you believe that this document breaches copyright please contact us at vbn@aub.aau.dk providing details, and we will remove access to the work immediately and investigate your claim.

Loss and Thermal Modeling of Metal Oxide Varistors (MOV) Under Standard Current Surge Mission Profile

Ionuț Vernica¹, Per Thåstrup Jensen², Huai Wang¹, Francesco Iannuzzo¹, Susanne Otto², and Frede Blaabjerg¹

¹ Department of Energy Technology, Aalborg University, 9220 Aalborg Øst, Denmark

² FORCE Technology, 2970 Hørsholm, Denmark

Email: iov@et.aau.dk, ptj@force.dk, hwa@et.aau.dk, fia@et.aau.dk, suo@force.dk, and fbl@et.aau.dk

Abstract—Because of their crucial role in protecting power electronic equipment against over-voltages and transients, metal oxide varistors (MOV) represent a key component of the electrical system. Although improper heat dissipation and internal temperature rises can lead to a significant decrease in performance or even to a wear-out failure of the MOV, there are very few studies in the literature describing the thermal modeling of varistors. Thus, in this paper, an instantaneous loss and thermal modeling procedure for MOV under a standard current surge mission profile is proposed. Initially, the specification and characteristics of a study-case varistor are presented, followed by a detailed description of the electro-thermal modeling procedure. Afterwards, the thermal behavior of the MOV is investigated and the differences between the heating and cool-down thermal models are highlighted. Finally, in order to validate the proposed electro-thermal models, the temperature of the varistor is measured with an infrared camera. The experimental measurements are in well agreement with the simulation results, and thus, providing an initial validation of the proposed modeling procedure.

Index Terms—Metal oxide varistor, surge current, power loss model, thermal model.

I. INTRODUCTION

Nowadays, with the ever-growing number of power semiconductor devices used in mission-critical applications, cost constrains and reliability requirements are becoming more and more stringent. In many applications (e.g., pump drives, street lightning, home appliances, etc.), over-voltages and transients generated by lightning strikes or non-ideal grid conditions, are among the main causes of failure in semiconductor components [1]. These failures will inherently lead to an overall life-cycle cost increase of the electrical system, due to the expenses associated with maintenance and downtime.

In order to protect the power electronic components and equipment against voltage and current surges, the metal oxide varistors (MOV) are connected in parallel with the necessary sub-assembly, and thus forming a low-resistance shunt during over-voltage occurrences [2].

However, in order for the MOV to operate correctly, the absorbed electrical energy must be converted into thermal energy and dissipated quickly into the ambient [3]. Otherwise, the increase in temperature will lead to the MOV operating outside its operating temperature limit, which can result in a decrease in performance, or even a failure. Similarly, the

negative impact of rising temperature on the lifetime of MOV has been shown in [4].

Thus, an accurate thermal modeling of the MOV under actual operating conditions becomes nearly crucial. Unfortunately, there are little to no studies throughout the literature investigating the instantaneous thermal behavior of MOV.

Consequently, in order to address this issue, the power loss and thermal modeling of a MOV operating under standard current surge mission profile is proposed and investigated in this paper. Initially, the varistor specifications and its operating requirements are introduced. Afterwards, a brief description of the electro-thermal modeling procedure is presented and the resulting thermal behavior of the varistor under the given current surge mission profile is highlighted. Finally, experimental measurements are used in order to validate the simulation results and the thermal modeling procedure.

II. SPECIFICATIONS AND TYPICAL REQUIREMENTS FOR METAL OXIDE VARISTORS

In this paper, a disk type varistor with epoxy resin coating is used as study-case. As shown in Fig. 1, the zinc oxide (ZnO) plate has a thickness of 2.9 mm and a diameter of 14 mm, and according to the manufacturer datasheet, the nominal operating temperature of the varistor ranges from -40 °C up to 85 °C [5].

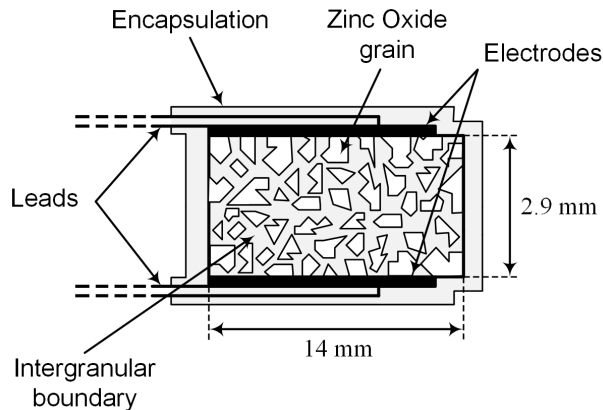

Fig. 1. General structure of a ZnO varistor.

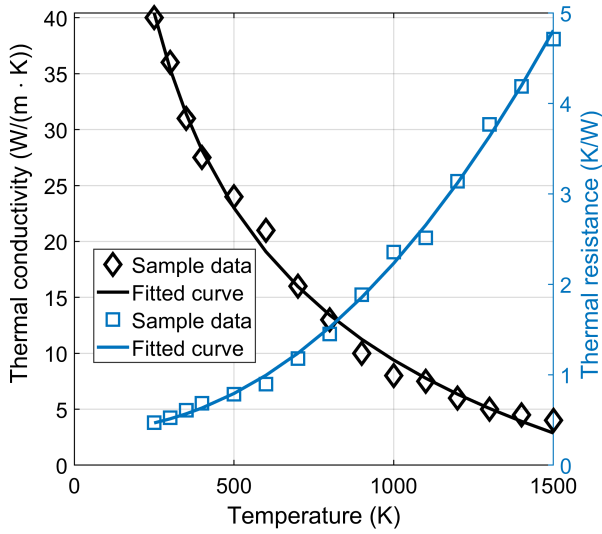

Fig. 2. Temperature dependency of ZnO thermal conductivity and thermal resistance [6].

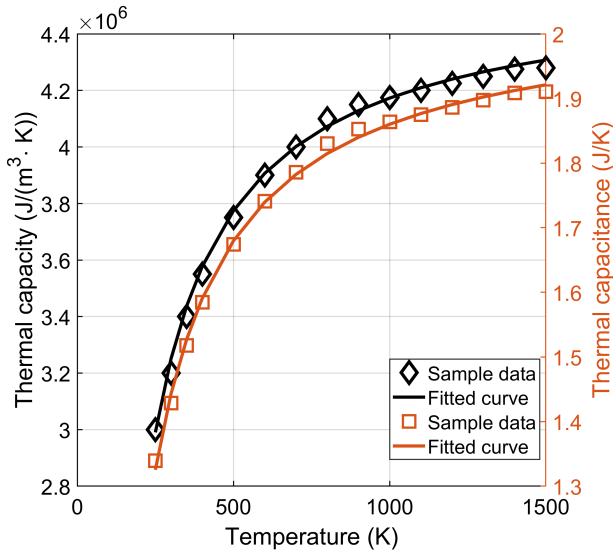

Fig. 3. Temperature dependency of ZnO specific heat and thermal capacitance [6].

As presented in [6], the thermal properties of the ZnO compound vary strongly with temperature. Despite the ZnO core inside the body of the varistor reaching very high temperatures (most likely, larger than 1000 K) during a surge current pulse, the temperature rise seen on the surface of the component is much less. This is mainly due to the slow propagation of the heat to the surface and due to the surge energy distribution over the volume of the varistor. Thus, based on the data from [6], the thermal conductivity and thermal capacity characteristics of ZnO can be calculated as a function of temperature, and are plotted in Fig. 2 and Fig. 3, respectively.

In order to correctly include the temperature dependency

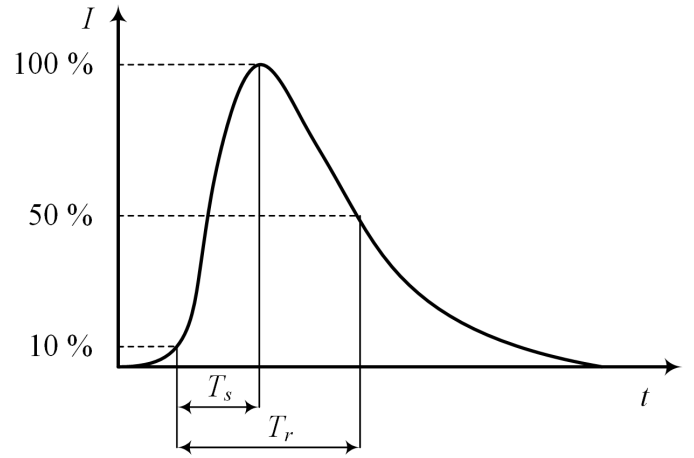

Fig. 4. Surge current pulse waveform defined by IEC 60060 [8].

of the varistor characteristics into its thermal model, the thermal resistance (R_{th}) and thermal capacitance (C_{th}) have to be determined. Thus, from the given characteristics and the geometrical dimension of the varistors, the thermal resistance can be calculated according to the following equation,

$$R_{th} = \frac{t}{A \cdot k_{th}} \quad (1)$$

where t is the thickness of the varistor, and k_{th} is the thermal conductivity. Similarly, the thermal capacitance is computed based on the formula given below,

$$C_{th} = q_{th} \cdot V \quad (2)$$

where V is the volume of the varistor, and q_{th} is the thermal capacity.

The resulting thermal resistance and thermal capacitance characteristics can be utilized to describe the thermal behavior of the MOV as a function of temperature, within a RC Foster thermal network [7], and are shown in Fig. 2 and Fig. 3, respectively.

In order to operate correctly, the MOV must be able to present a maximum energy absorption capability defined by the IEC 60060 standard [8] and to withstand a current surge pulse described by the waveform shown in Fig. 4. The current pulse rises from 10% of its nominal value to its peak value within $8 \mu s$ (T_s) and then decreases to half of its peak value in $12 \mu s$ ($T_r - T_s$). The mission profile that will be considered within this paper will consist of five consecutive current surge pulses (as shown in Fig. 4), which will be repeated at a fixed interval of 8 seconds.

III. ELECTRO-THERMAL MODELING PROCEDURE

According to the mission profile-based thermal characterization of power electronic components [9–11], the proposed modeling concept for the electro-thermal behavior of MOV is shown in Fig. 5. The current pulse mission profile (I), together

Electro-thermal Modeling of Metal-Oxide Varistors (MOV)

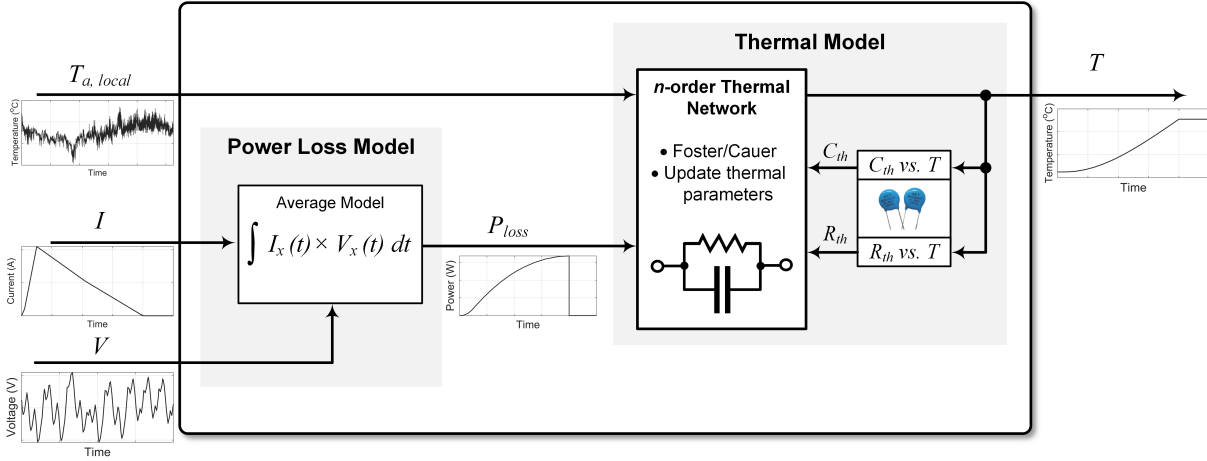

Fig. 5. Generic electro-thermal modeling procedure for MOV.

with the test voltage (V) will represent the inputs to the power loss model, which will calculate the total losses generated by the varistor under the given test conditions. Afterwards, the power losses (P_{loss}) and the local ambient temperature ($T_{a,local}$) are included into the thermal model, and translated to the temperature of the varistor.

Additionally, the resulting varistor temperature (T) will represent a feedback to the thermal model, in order to characterize the temperature dependency of the ZnO compound thermal resistance and thermal capacitance (according to the thermal properties presented in Fig. 2 and Fig. 3).

The average power losses dissipated by the varistor can be determined based on the instantaneous surge current pulse ($I_{peak} = 1050$ A) and the voltage drop ($V = 1350$ V) across

the varistor during the current flow.

Thus, the following equation can be utilized:

$$P_{loss} = \frac{1}{T_{pulse}} \int_{t_0}^{t_1} v(t) \cdot i(t) dt \quad (3)$$

where T_{pulse} is the current pulse duration, t_0 is the start time of the current pulse, t_1 is the end time of the current pulse, $v(t)$ is the instantaneous voltage drop across the varistor, and $i(t)$ is the instantaneous surge current pulse. The resulting power losses generated by the MOV under the given mission profile and operating conditions are presented in Fig. 6.

With respect to the MOV thermal model, due to the thermal properties of the ZnO compound [6], two thermal networks with different thermal time constants are employed in order to model the varistor heating and cool-down phases. An overview of the varistor thermal model is shown in Fig. 7.

Even though during both temperature cycles (heating/cool-down) the RC network is built based on a first-order transfer function, the values of the thermal resistance and thermal ca-

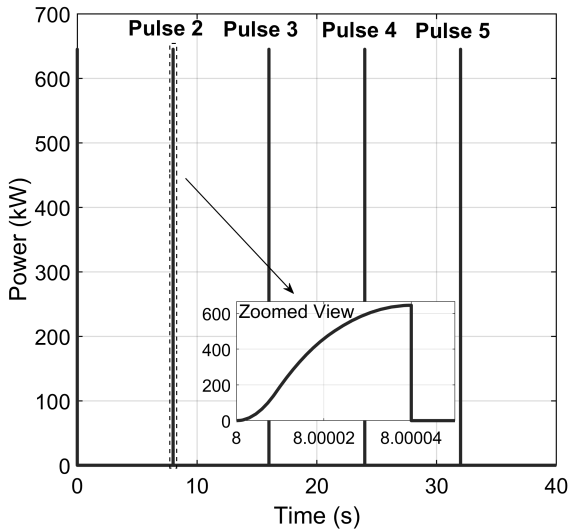

Fig. 6. Average power loss dissipated by the ZnO varistor under the 5-pulse 1050 A current surge mission profile.

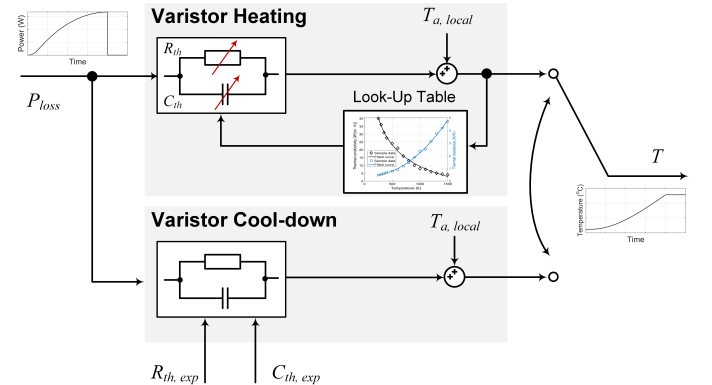

Fig. 7. Proposed dynamic thermal modeling for MOV under heating and cool-down phases.

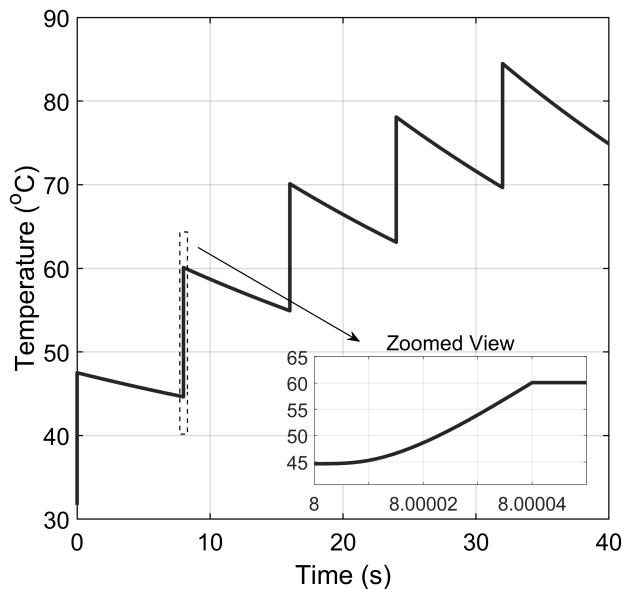

Fig. 8. Thermal behavior of the ZnO varistor under the given current surge mission profile.

capacitance will be different, according to the varistor's thermal phase.

During the heating phase, the thermal resistance and thermal capacitance are updated continuously according to their temperature dependency curves shown in Fig. 2 and Fig. 3, which are included as a look-up table.

On the other hand, during the cool-down phase of the varistor, the thermal network is built based on the empirical thermal resistance ($R_{th,exp}$) and capacitance ($C_{th,exp}$) values, which have been observed and fitted throughout experimental testing.

By employing the thermal model presented in Fig. 7, the power losses generated by the varistor under the given current surge mission profile are used in order to determine its thermal behavior. Considering a local ambient temperature ($T_{a,local}$) of 31 °C, the resulting thermal dynamics are shown in Fig. 8,

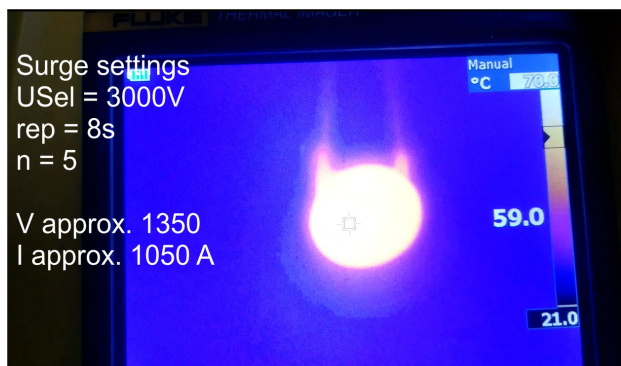

Fig. 9. Experimental recording using IR camera of varistor thermal behavior under given surge mission profile.

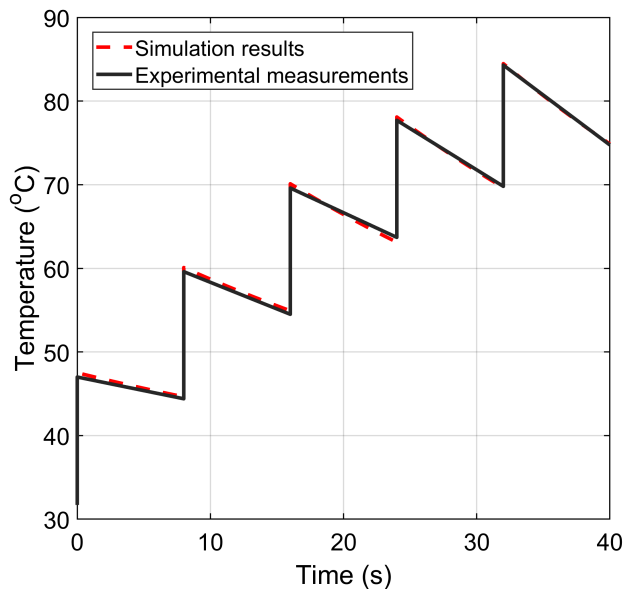

Fig. 10. Comparison between the experimental and simulation temperature swings of the ZnO varistor.

from which it can be observed that a high dynamic temperature swing occurs during the current pulse period, followed by a slow cool-down phase. As previously mentioned, this thermal behavior is due to the internal thermal properties of the ZnO core of the varistor.

IV. EXPERIMENTAL VERIFICATION

The thermal behavior of the MOV has been experimentally tested under the given study-case mission profile. Five current pulses, 40 microseconds each, have been applied to the varistor with an 8-second interval between them. A peak current amplitude of 1050 A has been considered, while the voltage drop across the varistor has been set to approximately 1350 V. The temperature has been recorded via an infrared (IR) camera as shown in Fig. 9, and the experimental thermal dynamics of the varistor are shown together with the simulation results in Fig. 10. From it, it can be inferred that the thermal measurements are in good agreement with the simulation results, thus providing an initial validation of the proposed thermal model.

V. CONCLUSIONS

In this paper an electro-thermal modeling procedure for a metal oxide varistor (MOV) has been proposed and investigated. Initially, the main specifications of the varistor and some of its typical application requirements have been introduced. Afterwards, the power loss and thermal loading models of the varistor have been discussed, demonstrating the dynamic model employed in order to characterize the varistor during its heating and cool-down phases. The loss and thermal dynamics of the MOV have been analyzed under standard surge-current mission profiles. Finally, experimental

results have been provided in order to validate the proposed thermal model and the different thermal time constants of the heating and cool-down phases. The simulation results are in well agreement with the experimental measurements, thus an initial validation of the proposed thermal model has been provided. Further testing and validation are required in order to verify the robustness of the proposed electro-thermal modeling procedure, and to facilitate the reliability modeling of MOV.

REFERENCES

- [1] TDK, "SIOV metal oxide varistors. General technical information." Available online [2019]: <https://www.tdk-electronics.tdk.com/download/185716/8954d4a78154a9da5c70a7119fa03e86/siov-general.pdf>
- [2] Vishay BCComponents, Tech. Note 29079, 2013.
- [3] S. M. Meysam, and M. Mirzaie, "Thermal balance diagram modelling of surge arrester for thermal stability analysis considering ZnO varistor degradation effect," *IET Gener. Transm. Distrib.*, vol. 10, no. 7, pp. 1570-15581, 2016.
- [4] Y. Wen, and C. Zhou, "A novel method for predicting the lifetime of MOV," *IEEE Trans. Power Del.*, vol. 19, no. 4, pp. 1688-1691, 2004.
- [5] Datasheet: S14K250 Leaded Varistor, Available online [2019]: <https://www.digchip.com/datasheets/parts/datasheet/2135/S14K250-pdf.php>
- [6] H. Morkoc, and U. Ozgur, *Zinc Oxide: Fundamentals, materials and device technology*, 2009, Wiley-VCH Verlag GmbH & Co KGaA, Weinheim.
- [7] Y. A. Cengel, and R. H. Turner, *Fundamentals of thermal fluids sciences (2nd edition)*, McGraw-Hill International Edition, 2015.
- [8] IEC 60060, "High-voltage and high-current test techniques," European Committee for Electrotechnical Standardization, Belgium, Feb. 2015.
- [9] K. Ma, M. Liserre, T. Kerekes, and F. Blaabjerg, "Thermal loading and lifetime estimation of for power devices considering mission profiles in wind power converter," *IEEE Trans. Power Electron.*, vol. 30, no. 2, pp. 590-602, 2015.
- [10] I. Vernica, H. Wang, and F. Blaabjerg, "Design for reliability and robustness tool platform for power electronic systems – Study case on motor drive applications," *Proc. of IEEE APEC*, 2018, pp. 1799-1806.
- [11] H. Wang, P. Davari, H. Wang, D. Kumar, F. Zare, and F. Blaabjerg, "Lifetime estimation of DC-link capacitors in adjustable speed drives under grid voltage unbalances," *IEEE Trans. Power Electron.*, vol. 34, no. 5, pp. 4064-4078, 2019.