



## On the Stability of Power Electronics-Dominated Systems

### *Challenges and Potential Solutions*

Peng, Qiao; Jiang, Qin; Yang, Yongheng; Liu, Tianqi; Wang, Huai; Blaabjerg, Frede

*Published in:*

IEEE Transactions on Industry Applications

*DOI (link to publication from Publisher):*

[10.1109/TIA.2019.2936788](https://doi.org/10.1109/TIA.2019.2936788)

*Creative Commons License*

CC BY 4.0

*Publication date:*

2019

*Document Version*

Publisher's PDF, also known as Version of record

[Link to publication from Aalborg University](#)

*Citation for published version (APA):*

Peng, Q., Jiang, Q., Yang, Y., Liu, T., Wang, H., & Blaabjerg, F. (2019). On the Stability of Power Electronics-Dominated Systems: Challenges and Potential Solutions. *IEEE Transactions on Industry Applications*, 55(6), 7657-7670. Article 8809097. <https://doi.org/10.1109/TIA.2019.2936788>

#### **General rights**

Copyright and moral rights for the publications made accessible in the public portal are retained by the authors and/or other copyright owners and it is a condition of accessing publications that users recognise and abide by the legal requirements associated with these rights.

- Users may download and print one copy of any publication from the public portal for the purpose of private study or research.
- You may not further distribute the material or use it for any profit-making activity or commercial gain
- You may freely distribute the URL identifying the publication in the public portal -

#### **Take down policy**

If you believe that this document breaches copyright please contact us at [vbn@aub.aau.dk](mailto:vbn@aub.aau.dk) providing details, and we will remove access to the work immediately and investigate your claim.

# On the Stability of Power Electronics-Dominated Systems: Challenges and Potential Solutions

Qiao Peng , *Student Member, IEEE*, Qin Jiang, Yongheng Yang , *Senior Member, IEEE*, Tianqi Liu, *Senior Member, IEEE*, Huai Wang , *Senior Member, IEEE*, and Frede Blaabjerg , *Fellow, IEEE*

**Abstract**—The modern power system is becoming more complicated due to the ever increasing penetration of power electronics, which is referred to as a power-electronics-dominated system (PEDS). In this case, the analysis, control, and operation of the entire power system should tune with the energy-paradigm transition pace, where the challenges should be properly tackled. After the brief introduction of grid-connected converters, this article explores stability challenges of PEDSs, especially on the low inertia issue and multimescale characteristics, as well as the dynamics when connected to weak grids. The low inertia issue is considered as one of great challenges that power electronics introduce to the conventional power grid. Accordingly, the stability issues of PEDSs are discussed. The exploration reveals that the multimescale coupling among various control loops and the mutual effects of multiple converters demand much more attention than ever before. The coordinated control of converters for the global stability of PEDSs is also summarized, part of which offers the possibility to solve the inertia problem. This article serves as an inspiration on potential solutions to these issues. In order to provide a more intuitive impression of the inertia problem in PEDSs, a case study is exemplified to highlight the analysis and discussion.

**Index Terms**—Low-inertia systems, multimescale analysis, mutual effect, modeling, power-electronics-dominated systems (PEDSs), power electronic converters, stability and control, virtual inertia.

## NOMENCLATURE

AGC	Automatic generation control.
AVR	Automatic voltage regulator.
CCM	Component connection method.
DFIG	Doubly fed induction generator.
DPGS	Distributed power generation system.
ESS	Energy storage system.

FSM	Frequency sensitive mode.
IR	Inertia response.
LCC	Line-commutated converter.
LCC-HVDC	LCC-based high voltage direct current.
MIESCR	Multiinfeed interactive effective short-circuit ratio.
MIIF	Multiinfeed interaction factor.
MPC	Model predictive control.
MPP	Maximum power point.
MPPT	Maximum power point tracking.
MTDC	Multiterminal direct current.
OPF	Optimal power flow.
PCC	Point of common -coupling.
PEDS	Power electronics-dominated system.
PI	Proportional-integral.
PIV	Power-internal voltage.
PLL	Phase-locked loop.
PMSG	Permanent-magnet synchronous generator.
PSS	Power system stabilizer.
PV	Photovoltaic.
PWM	Pulsewidth modulation.
RSC	Rotor-side converter.
SG	Synchronous generator.
SRF	Synchronous reference frame.
TSO	Transmission system operator.
VSC	Voltage source converter.
VSG	Virtual synchronous generator.

## I. INTRODUCTION

THE current energy network is being retrofitted with more renewable energy sources like wind and solar energy [1], [2]. By 2018, the global installed capacity of the wind power achieved 592 GW, and over 300 GW of new capacity is expected to be added until 2023 [3]. On the other hand, the solar power, mainly integrated via the PV technology, remains also at a high growth rate. By the end of 2018, the global cumulative installed PV capacity reached 509 GW [4]. In the conventional power grid, the source, network, and load are mainly electromagnetic equipment, e.g., SG, transformers, and induction motors. However, unlike to that, the modern power grid is increasingly integrated with renewable energy, heavily relying on static power electronics converters [5]. This makes the entire power grid more complicated. Moreover, in this case, the boundary between ac and dc grids becomes indistinct in such highly aggregated

Manuscript received December 27, 2018; revised June 11, 2019; accepted August 16, 2019. Date of publication August 20, 2019; date of current version November 7, 2019. Paper 2018-HPC-1169.R1, presented at the 2018 IEEE Industry Applications Society Annual Meeting (IAS), Portland, OR, USA, Sep. 23–27, and approved for publication in the IEEE TRANSACTIONS ON INDUSTRY APPLICATIONS by the High Performance Power Electronic Converters: Topologies, Control, and Devices of the IEEE Industry Applications Society. This work was supported by THE VELUX FOUNDATIONS under the VILLUM Investigator Grant REPEPS (Award Ref. No.: 00016591). (*Corresponding author: Yongheng Yang.*)

Q. Peng, Y. Yang, H. Wang, and F. Blaabjerg are with the Department of Energy Technology, Aalborg University, Aalborg 9220, Denmark (e-mail: qpe@et.aau.dk; yoy@et.aau.dk; hwa@et.aau.dk; fbl@et.aau.dk).

Q. Jiang and T. Liu are with the College of Electrical Engineering, Sichuan University, Chengdu 610065, China (e-mail: jiangqin\_jq@stu.scu.edu.cn; tqliu@scu.edu.cn).

Color versions of one or more of the figures in this article are available online at <http://ieeexplore.ieee.org>.

Digital Object Identifier 10.1109/TIA.2019.2936788

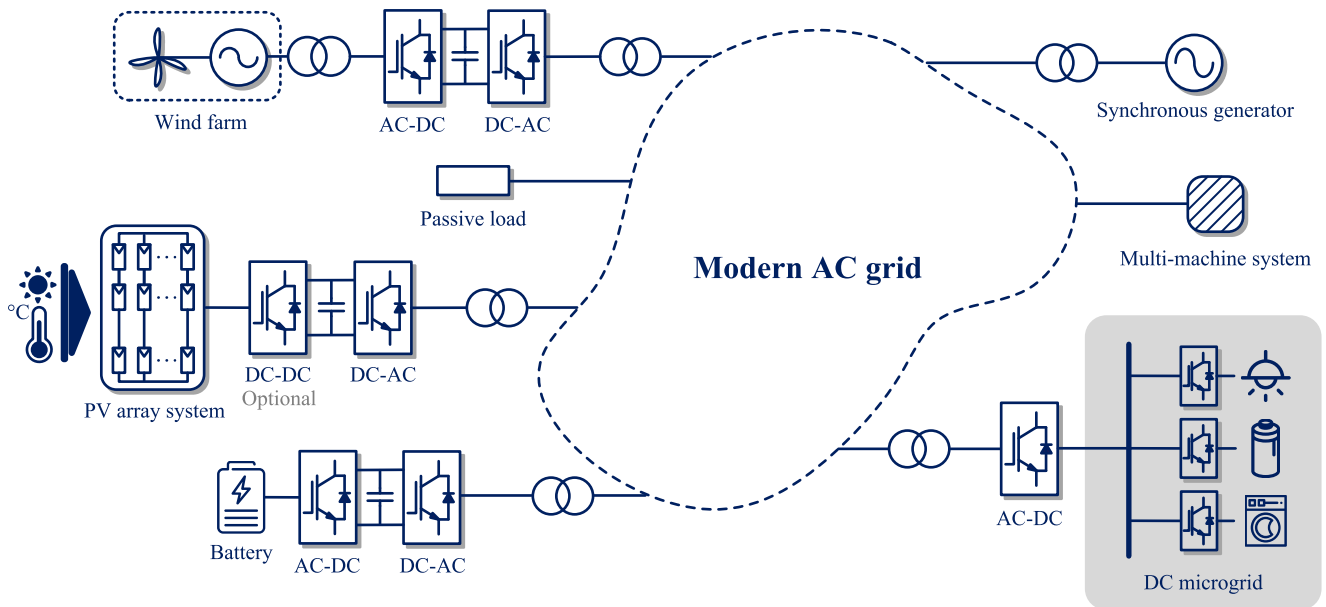

Fig. 1. Highly aggregated PEDS.

PEDSs, consisting of wind farms, PV plants, SGs, induction motors, etc., as exemplified in Fig. 1.

With this background and the continuous evolution of the energy paradigms, the modeling and dynamic analysis of PEDSs become more important than ever before. This ensures providing theoretical foundation and technological support for the cost-effective enhancement of the entire power system in terms of availability, stability, and reliability. For instance, in the literature, it has been demonstrated that the stability concern of MTDC systems or dc microgrids is one of the emerging issues, requiring much attention [6]–[8]. However, the focus was mainly put on the analysis on the dc side, mainly contributing to the coordinated control strategy for the power sharing in the dc grid [9], and the entire dc grid was taken as a large generating unit for the ac grid. Similarly, the focus of most of the research on the ac microgrids is mainly on the power sharing among converters [10], [11]. The cross-effect or mutual interactions between the ac and dc grids have not been fully explored. In addition, attempts have been made to address the harmonic resonance issue in power converter systems [12], e.g., the CCM and impedance-based approach [13], and the interaction-admittance model method [14]. However, a complete picture and a common understanding of the multiconverter system interactions have not yet been fully discussed. This becomes more important, as the power electronic penetration is still increasing.

In fact, power electronics have fast dynamics, but also the integration of multiple power converters brings instability. The root cause of the system instability is complicated and cross affected, which has not been thoroughly clarified yet. One of the common and critical reasons is the lack of physical inertia. Therefore, many measures have been taken to enhance the inertia of power converters. For instance, the power converter can be controlled to mimic the behaviors of SGs, whose inertia is provided by the rotating mass. This concept is known as the VSG and the emulated inertia is referred to as virtual inertia [15],

[16]. The relationship between the virtual inertia of VSGs and the system transient stability was presented in [17], following which a self-adaptive inertia and damping control was developed in [18]. It should be noted that the analysis or control strategy depends on an assumption that the inertia is provided by a large ESS or alike, i.e., the inertia requirement can be always satisfied, which is, however, not economical or practical. An alternative to emulate inertia can be achieved through the dc-link capacitor (notably, it can also be considered as a storage device) of the power converters [19], [20]. This inertia provision scheme has been effectively demonstrated for the short-term frequency support. In addition, the dc-link capacitor lifetime performance may be affected when the inertia emulation is enabled. Nonetheless, the virtual inertia should be further enhanced in a way that the well-established theory and control methods for the conventional SGs may be employed.

Consequently, additional attention has been paid to express the virtual inertia-related external characteristics of power converters with vector control strategies by a universal model. For example, in [21], a small-signal model of power converters with a vector control strategy was introduced to illustrate the impact of system parameters and control loops on the dc-link voltage stability. In [22], the concept of a multitime-scale control loop was depicted, based on which a model reflecting the PIV characteristics of converters was developed, and the stability analysis was subsequently achieved in [23]. Although the model may be overcomplicated and it is unnecessary to strictly model the converter in analogy with an SG, the modeling concept in a universal way to represent the power converter external characteristics is instructive and meaningful.

To shed light on the aforementioned issues, grid-connected power converters with different control strategies are discussed in this article. Based on our previous study [24]–[26], focuses are put on the associated stability issues, including the virtual inertia characteristics, the interaction between the power converters and

the ac grid, and the mutual effect among multiple converters. Prospective solutions are briefed for future studies, which may lay the foundation for the control system designs of the PEDSs. The rest of this article is organized as follows. Section II introduces the control of the grid-connected converters. Section III emphasizes the stability issues of the grid-connected converters, where the priority is the low inertia issue. The stability challenges in PEDSs are then depicted in Section IV, where, seen from the authors' perspective and understanding, possible solutions are put forward. In order to afford intuitive impression on the control interaction in the systems, a case study is given in Section V. Finally, concluding remarks are provided in Section VI.

## II. CONTROL AND MODELING OF GRID-CONNECTED CONVERTERS

This section will introduce the control strategies of power electronic converters. Among various control schemes, nonlinear control methods are attracting more popularity. One of the most studied methods is the predictive control, including the deadbeat control [27], general MPC [28], and modified predictive controls [29], [30]. Sliding mode control and artificial intelligence-based control are introduced to grid-connected converters as well [31], [32]. However, most of these nonlinear control methods require enormous computational burden. The complicated mathematical description makes it difficult to explain and further solve potential instability issues coming with the nonlinearity [33]. Although most of the nonlinear controllers proposed for the power converters are validated in laboratories, practical applications are still not widespread. Thus, the impact of nonlinear control methods on PEDS stability is not specifically discussed in this article. At present, the conventional linear controls are still the most mature and widely applied control methods. Notably, the following discussion on the stability issues and potential solutions may be also applicable to nonlinear control-based systems.

### A. Basic Control

In general, the power converters can be divided into three categories according to their control strategies or objectives, i.e., grid-feeding, grid-supporting, and grid-forming converters [34]. The grid-feeding converters usually operate as current sources to inject active and/or reactive power to the grid [35], [36]. The grid-forming converters can only operate in the islanded mode [37], while the grid-supporting ones are able to provide ancillary services to the grid (e.g., frequency regulation), being operated as either current or voltage sources [34]. In the PEDS, the system is significantly scaled up, and the diversity of power converters challenges the modeling, analysis, control, and operation of the entire system. The generality of power converters with various control strategies as aforementioned should thus be explored.

For the linear-controlled grid-connected converters, especially those for the large-scale renewable energy integration and long-distance power transmission, the dual-loop vector control strategy is widely used. In fact, in the current VSC-based projects in operation, the converters are mostly equipped with the dual-loop vector control strategy [38]–[40]. In general, the

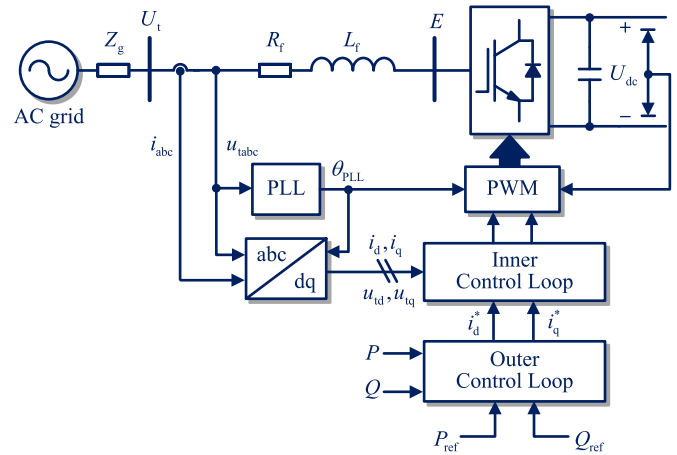

Fig. 2. Schematic diagram of a grid-connected converter with a dual-loop vector control structure. In this control,  $U_t$ ,  $E$ , and  $U_{dc}$  are the terminal voltage (voltage on the PCC), internal voltage (output ac voltage), and the dc-link voltage of converter, respectively,  $Z_g$  is the equivalent impedance of ac grid,  $R_f$  and  $L_f$  are the equivalent resistance and inductor of converter loss with the filter, respectively,  $P$  and  $Q$  are the actual active and reactive power on the PCC, respectively,  $P_{ref}$  and  $Q_{ref}$  are the reference active and reactive power on the PCC, respectively,  $i$  and  $i^*$  are the actual ac current and the reference ac current for the three phases, respectively,  $\theta_{PLL}$  is the terminal voltage phase angle tracked by the PLL, the subscripts  $d$  and  $q$  denote the corresponding components in the  $dq$ -reference frame, and the subscripts  $abc$  denote the components in the nature reference frame.

dual-loop vector control strategy includes an outer control loop and an inner control loop [41], [42]. The outer control loop is generally in charge of the control of the output power, the dc-link voltage, or the ac voltage at the PCC, depending on the converter types and strategies. The inner control loop regulates the converter internal voltage references for the PWM, depending on the current references generated by the outer control loops. A typical  $dq$ -frame-based dual-loop vector control structure for a grid-connected system is exemplified in Fig. 2, where the system can be either an inverter system (with a dc source) or a rectifier system (with a dc load). It should be noted that the outer control loop can be modified as required, and the active power control and reactive power control are selected as the outer control loop in this example.

Notably, the emergence of various modified control strategies cannot be ignored. For example, the droop controls are widely applied in microgrids [43], and adaptive droop-control schemes are adopted to enable a multifunctional control system [44], [45]. These attempts make the control of the PEDS much more complicated than before. However, the modified controls can be treated as extensions of the basic control with additional parts. Thus, the research of the basic control, including the discussion in this article, can be applied as well with minor modifications.

### B. Grid Synchronization

In the dual-loop vector control strategy, one important part is the grid synchronization, as demonstrated in Fig. 2. It enables the independent tuning of the active power and reactive power by controlling the active power ( $d$ -axis) current and reactive power ( $q$ -axis) current, respectively. Proportional-integral (PI)

controllers are generally adopted in the  $dq$ -frame control system. It is worth mentioning that actually, the transformation of the natural  $abc$ -frame currents into the  $dq$ -frame builds the connection between power converters and conventional power electrical devices such as SGs. Thus, the grid voltage phase angle information is important to achieve the reference frame transformation, and it is generally extracted by means of a PLL [46]. Among the prior-art PLL techniques, the SRF-PLL is the most commonly used method. It gives a fast and precise detection of grid voltage phase angle [47]–[49].

Although the basic SRF-PLL works well under the balanced grid conditions, it would be weak when the grid operation becomes unbalanced, as the positive-sequence components detected by the SRF-PLL may be affected by the negative-sequence components [50]. Moreover, the SRF-PLL is very sensitive to phase angle jumps of the grid voltage, which decreases the stability of converters under disturbances [51]. Despite the diversity of PLL technologies, the interaction between the PLL and other control loops, and the stability problem caused by the PLL under weak grids are important as well. This will be discussed in the following sections.

### C. Universal Modeling of Grid-Connected Converters

Modeling is an essential tool for stability analysis. For power converters, two typical modeling methods are used, i.e., the impedance-based and the state-space modeling. The impedance-based method is friendly in reduction of the calculation burden and is independent on system topologies [13], [52]. As the frequency characteristics of power converters and the grids can be obtained based on their equivalent impedances in the frequency domain, this method attracts much interest in dealing with harmonic problems [53]–[55]. Another method is the state-space model, of which the advantages include that the physical meaning of the model and the relationship between variables are clear, and the well-developed analysis tools based on the state-space theory can be used conveniently [56], [57].

The state-space model is more difficult to obtain mathematically, as the model of the converters is generally coupled with the grid, i.e., the parameters of the grid may be present in the converter's model. This is obviously not desired in the analysis of the PEDS. Although the impedance-based method is able to independently model the converter and the grid without parameters coupling, it is somehow troublesome to measure and calculate the impedance when there is a large amount of power converters. Thus, how to model the converters by addressing these issues is a challenge. Continuous research efforts have thus been devoted into the modeling. For instance, a state-space modeling method for grid-connected converters without grid parameters was introduced in [58], based on which a model considering effects of dead time and time delays was developed in [59]. This modeling method enables the universal stability analysis of the grid-connected converters.

In addition to the modeling method, the generality of the model is another important concern. As described in the last section, the control strategies of converters are complicated. The dynamics of converters differ with the control strategies.

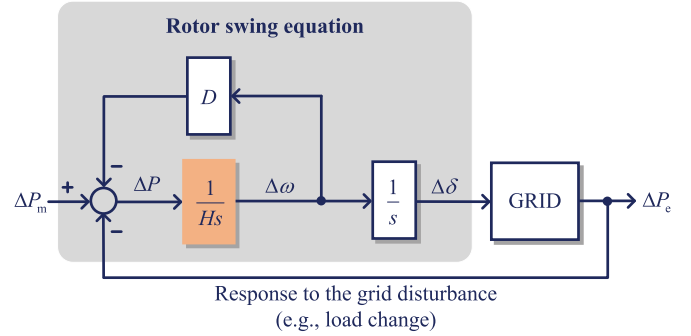

Fig. 3. Small-signal swing equation of an SG, where  $\Delta P$  is the unbalanced power between the mechanical power and electromagnetic power, where  $P_m$ ,  $P_e$ ,  $H$ ,  $\omega$ ,  $D$ , and  $\delta$  are the mechanical power (provided by the prime mover), electromagnetic power (output power), inertia constant, angular frequency, damping factor, and power angle of the SG, correspondingly, and  $\omega_0$  is the rated angular frequency.

For the grid-feeding converters, the control objectives are their output active and reactive power, while for the grid-forming converters, they are designed to regulate the voltage amplitude and frequency of the local grid. When these converters are connected to the same grid, what parameters and tools can be used to assess the stability of the converters and further the system should be discussed cautiously. That is to say, the grids need to determine the necessary information from converters. In this way, the stability of the PEDSs can be conducted by aggregating the universal converter model.

## III. STABILITY OF GRID-CONNECTED CONVERTERS

Before discussing the stability of PEDSs, the stability of grid-connected converters should be addressed. This section will illustrate the stability of grid-connected converters from various aspects and explore potential solutions to the stability.

### A. Power-Internal Voltage Characteristic

In the conventional multi-SG-based power systems, two of the most important stability issues include the power angle stability and voltage stability, which are closely related to the active power and reactive power, respectively [60], [61]. This is because the power distribution of the system can be adjusted by regulating the power angle of the generators. This self-adjusting process is achieved by the rotor motion in SGs, which is described as

$$\begin{cases} P_m - P_e = H\omega \frac{d\omega}{dt} + D\Delta\omega \\ \frac{d\delta}{dt} = \omega - \omega_0 \end{cases} \quad (1)$$

being the swing equation. Fig. 3 further presents the swing equation of an SG. As observed in Fig. 3, the output of the swing equation, i.e., the internal voltage phase angle, determines the grid power distribution, and then, the active power is fed back to the swing equation as an input. Additionally, as seen in Fig. 3, the inertia  $H$  decides the frequency response of the SG. Moreover, the inertia characteristic can be analyzed by the relationship between the active power  $P$  and the internal

voltage phase angle  $\delta$ , also referred to as the PIV characteristic of an SG. Accordingly, it may be valuable to model the power converters representing their PIV characteristics, which devotes to the overall analysis, especially the inertia issue of the PEDS.

For instance, attempts were made to establish the universal model that can reflect the PIV characteristics of power converters in [21] and [22]. In these cases, the relationship between the output power and internal voltages was demonstrated. Based on the model, the impact of control parameters, the converter operating point, and the grid stiffness on the stability of power converters can be investigated. Unfortunately, the application of these models for the entire system stability analysis has not been discussed. It requires more detailed analysis and modeling.

### B. Inertia Characteristics

For the SG, as there is mechanical-rotating mass, large physical inertia may be readily available to buffer the system dynamic responses. In contrast, for the grid-connected converters without mechanical rotors, either additional devices should be adopted or the control should be retrofitted to provide (virtual) inertia, i.e., absorb, or compensate for the transient energy; otherwise, the system may collapse under severe disturbances [62]. To achieve so, several virtual inertia solutions have been introduced in the literature, which will be reviewed in the following.

1) *Virtual Synchronous Generator With ESS*: To address the low inertia issue, the power converters can be arbitrarily designed or controlled to mimic the behavior of SGs, i.e., releasing the stored energy to damp the disturbances when needed. The grid-connected power converters operating in this way are referred to as VSGs. In this case, the inertia can be emulated and also directly adjusted, which makes it possible and flexible to use the emulated (virtual) inertia to stabilize the entire system [63], [64].

It should be noted that the virtual inertia of a VSG is limited by the ESS performance, e.g., batteries or supercapacitors [65]. The drastic development of ESS technologies is promoting the ESS as more viable and popular solutions for inertia support and primary frequency regulation in the future. However, completely emulating the power converter to an SG is not always the best option, as the inertia increase may sacrifice the advantages of power converters, including fast dynamics and high controllability. Thus, it deserves much attention to explore more universal inertia provision schemes in the PEDS.

2) *Virtual Inertia From the DC-Link Capacitor*: Some attempts have been made to seek the balance between inertia emulation and control flexibility. Instead of completely modifying the control of grid-connected converters, the dc-link capacitor, as an energy storage device, can be adopted to provide virtual inertia. Without additional ESS units, the virtual inertia can be emulated by charging and discharging the dc-link capacitor [23], [66]. Although the dc-link capacitor is generally unable to deal with large energy storage, it enables flexible frequency support from all power converters, especially in small-scale and relatively weak grids.

To achieve the inertia emulation by the dc-link capacitor, the dc-link voltage control should be modified. When there is energy

unbalance in the grid, the dc-link voltage will be regulated in a way to process the energy flow (i.e., emulating the inertia to stabilize the system). During this process, the energy unbalance is compensated, and the virtual inertia is generated by the dc-link capacitor. Clearly, the dc-link voltage control used to simulate the virtual inertia can be the conventional dual-loop vector control with minor modifications [67], the dc-link voltage-frequency droop control [20], or the self-synchronized dc-link voltage control [19].

It is worth mentioning that the significance of the virtual inertia from the dc-link capacitor is that it jumps out the limit of the VSG. That is, the rest of the power converter modeling and control may remain. As a consequence, it may stimulate further research in the inertia from complicated PEDSs.



3) *Inertia Emulating Control of Renewable Energies*: In addition to the virtual inertia from ESSs or dc-link capacitors, inertia can be provided from renewable energy sources. For wind turbine systems, especially the DFIG systems, the virtual inertia can be provided either by the dc-link capacitor or by recoupling the rotor mass to the grid frequency [68], [69]. More specifically, for the latter solution, the inertia can be generated by the rotating mass of the DFIG (i.e., control the rotor motion). In this case, a frequency response loop in the MPPT loop of the rotor-side converter should be introduced, and the active power reference can be adjusted following the grid frequency deviation [70], [71]. As the DFIG is operating in the MPPT mode in steady state, the inertia from the rotor motion can only deal with under-frequency conditions [62].

The inertia emulating is also applicable to PV systems, where the ESS or dc-link capacitor-based inertia provision is also feasible [72], [73]. In this case, the PV system keeps running in the MPPT mode and is barely affected by the frequency deviation, i.e., the PV system is operating as a constant current source without any grid support function. However, the output power of PV systems is fluctuating, and the frequent charging and discharging of energy storage devices (e.g., batteries and dc-link capacitors) are impractical and not economic-friendly. Thus, how to afford the virtual inertia by flexible PV output power control is of interest.

Various solutions have been reported in the literature. For instance, the coordinated frequency support control depending on the reserved power of PV systems was proposed in [74], where the linear frequency-power droop control and the inertia response control are included. By regulating the PV output power under the MPP, a specific amount of power can be reserved for the frequency support. Once the detected frequency is irregular, the PV unit can flexibly adjust its output power to balance the energy without the ESS [75]. Furthermore, an inertia emulating control of PV systems was developed in [76], where the PLL is replaced by a self-synchronous loop identical to the SG's and the frequency regulation loop complies with the swing equation of an SG.

To sum up, the possible inertia emulation/provision from PEDSs is shown in Table I [20], [62], where  $T_m$  and  $T_e$  are the input mechanical torque and output electromagnetic torque of the generator,  $\omega_r$  is the rotating speed of the SG rotor or wind turbine rotor,  $P_{dc}$  is the transient power of the energy storage

TABLE I  
POSSIBLE INERTIA EMULATING METHODS OF DIFFERENT DEVICES IN POWER ELECTRONICS-DOMINATED SYSTEMS

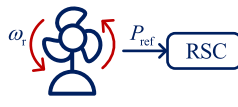
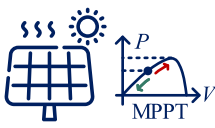
Device	Principle mapping	Inertia source	Energy form	Inertia restriction	Inertia cost
Synchronous generator		Rotor motion	Kinetic	Rotor specification	Mechanical loss
Energy storage device		Charge and discharge of device	Electrical	Capacity	Electrical loss
Wind turbine		Rotor motion	Kinetic	MPP	Mechanical loss
PV generation		Operating point adjustment	Electrical	MPP and reserved power	Limited output power

device,  $P_{ref}$  is the active power control reference of the RSC,  $P$  and  $V$  are the output active power and dc voltage of PV panels, respectively. It should be pointed out that the energy storage device in Table I can be the ESS in the VSG system or the dc-link capacitor in regular grid-connected converters. Beyond the solution in Table I, more extensive exploration is expected to strengthen the power systems with more and more power electronics. In this way, the virtual inertia of power converters should be quantitatively identified. By analyzing the inertia characteristics, the stability of the grid with power converters can be assessed [77].

### C. Multiscale Coupling of Control Loops

For a dual-loop vector-controlled converter, the bandwidth of the current control loop is typically designed depending on the switching frequency. The response of the inner current loop is generally in the millisecond range, and in contrast, the response time of the outer control loop is commonly ten times slower [78]. Due to the dynamic response distinction of the control loops, the entire control system should be analyzed in different timescales, where the cross-coupling effect should be explored. This concept is known as multiscale analysis [22], [79].

Under such a background, the instability in a PEDS may be amplified gradually due to the mutual effects among control loops. For example, the disturbance on the terminal voltage will affect the phase angle tracked by the PLL. As the  $dq$ -frame is generated according to this phase angle, it will affect the performance of the inner current controller and the dc-link voltage stability, and further, the output power of the converter [21]. On the other hand, the controllers in a small timescale may be designed to damp the disturbances in a large timescale. For instance, the low-frequency oscillations, which were conventionally damped by the PSS installed in the excitation system of an SG, can be tackled by additional controllers added on the active power control loops of LCCs or VSGs [80], [81].

In all, in the PEDS, to understand the mutual effect among control loops, it is important to model the system to decouple the control in various timescales in order to develop control strategies with ensured system stability. That is, for a particular timescale, what assumptions can be made and what dynamics can be ignored should be addressed properly.

### D. Stability Problems Due to Grid Stiffness

The grid stiffness is being altered by various factors, e.g., long transmission lines, solid-state transformers, or highly aggregated DPGSs [82]. The decreasing grid stiffness is threatening the stable operation of PEDSs. For example, when an  $LCL$  filter is adopted, the increase in the grid impedance decreases the filter resonance frequency and the system bandwidth, which may yield harmonic problems or instability [83]. In such a case, the grid impedance should be considered in the design phase of the filter and the control parameters [52], [82]. More importantly, the PLL performance is significantly affected by the grid stiffness. The decreased grid stiffness magnifies the negative effect of the PLL on the system damping, and the system is thus more likely to lose stability [84]. Additionally, it has been revealed that the interaction between the PLL and control loops has a significant impact on the system stability [21], [66], [79], [85], [86]. For instance, in [66], a dual-torque analysis method was presented to explore the impact of ac-bus voltage control on the dc-link voltage control stability in weak grids. Specifically, the ac-bus voltage control behaves as a lagging regulator for the dc-bus voltage control by providing phase-lagged damping and restoring virtual torques to the dc-link voltage stability [66]. When the grid stiffness decreases, the damping torque may be negative and the system is more vulnerable to disturbances, i.e., the ac-bus voltage control worsens the dc-link voltage control stability.

Notably, it has been verified in [84] that the VSC performs better than the LCC when grid stiffness decreases, and thus, the boundary between “weak” and “strong” grids with VSCs should

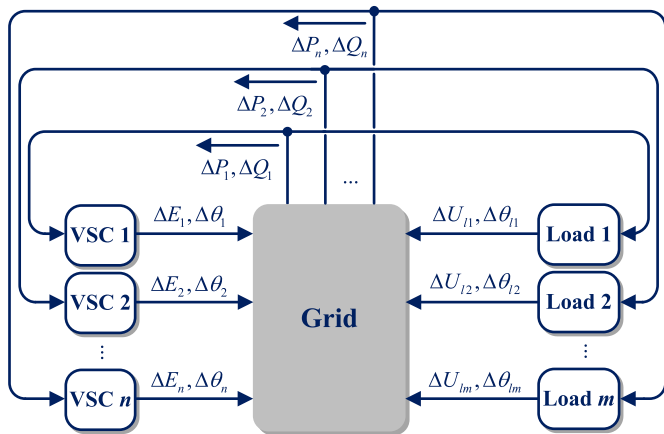
 Fig. 4. Universal model of multiconverter systems with  $n$  VSCs and  $m$  loads.

differ from that with LCCs. In that case, with the state-space model, the dynamics of control loops under weak grid conditions can be assessed, and the control parameters can be designed for optimal performance, correspondingly.

#### IV. STABILITY CHALLENGES AND POTENTIAL SOLUTIONS FOR THE PEDSS

As aforementioned, the PEDSSs are complicated with various power equipment. In such systems, not only the dynamics of power converters should be investigated, but also the mutual effect among converters and other devices, e.g., wind generators, PV panels, batteries, and SGs, should be addressed. Hence, many challenges to the stability and control emerge. Owing to the specialty of power electronic converters, the stability analysis methods used in multi-SG systems may not be directly applied in the PEDSSs. On the contrary, experience gained in such applications can be adopted. Enlightened by the analysis in multi-SG systems, this section will discuss the challenges (e.g., due to mutual effects) and potential solutions to the stability in multiple power converters-based systems.

##### A. Universal Model-Based Stability Analysis

The converter universal model reflecting the PIV characteristics has been discussed in Section III. Accordingly, the PIV characteristic and the stability of the entire PEDS can be assessed, as demonstrated in Fig. 4 [22]. It can be observed in Fig. 4 that the most important parameters, i.e., the amplitude and phase angle of the internal voltage of each power converter are considered in this model. When the universal model is considered in an ac grid, the operation matrix of the grid can be obtained, known as the Hessian matrix or the Jacobian matrix. By analyzing the characteristics of the matrix, the mutual effect among power converters and also the interaction with the ac grid may be disclosed. Notably, other power devices can be modeled in a similar way, i.e., modeling each device reflecting its PIV characteristics, and then, it will be straightforward to investigate the system stability.

As for the mutual effect among converters and other devices, the analysis methods used in multiinfeed LCC-HVDC systems can be referenced. For example, in the LCC-based systems, one of the most important problems is the commutation failure issue, which is generally caused by the grid voltage drops, so the MIIF is adopted to assess the voltage amplitude interaction and further the commutation failure possibility [87]. Inspired by this, the similar concepts, such as the multiconverter interaction factor, for the PEDSSs can be developed. However, for the VSC-based systems, as discussed previously, the interaction on the voltage phase angle may be more attractive, as it accounts for the performance of the PLL and thus, the control system. Additionally, another index, e.g., the MIESCR, can also be referenced for the stability analysis under weak grid conditions [88].

##### B. Cross-Effect of Power Devices in Multitimescale

The multitimescale coupling of control loops in grid-connected converters has been discussed in Section III. However, there are not only grid-connected converters in the PEDSSs. As shown in Fig. 1, the controllers or control strategies in the conventional multi-SG-based systems and renewable energy systems should also be considered when analyzing the control loops coupling in different timescales. For instance, in an SG, the AVR is in the voltage control timescale (hundreds of milliseconds) [89], while its inertia response to frequency is in the rotor speed control timescale (above seconds). The conventional low-frequency oscillation damping device—the PSS and the AGC adopted widely in distribution systems are working in the rotor speed control timescale as well [8], [90]. Moreover, with longer response time (above minutes), there are more control strategies at the dispatching level, including the power management strategy, OPF control [91], and active power reserve coordinated by the TSO [92]. Although the control strategies at the dispatching level are with slow response dynamics, the impact on the faster control loops cannot be ignored. For example, a grid frequency support method of the PV system was presented in [74], where the FSM and IR loops were added in the PV system control. These additional control loops, both of which were in the rotor speed control timescale, enabled the PV adjusting its output power to support the system frequency, where the reserved power was assigned by the TSO [74]. As a summary, the control timescales are briefly classified in [79] and enriched, as shown in Fig. 5.

It can be seen from Fig. 5 that, due to the sophisticated coupling of not only control loops but also power devices, it is more difficult to explore the dynamics of the PEDSSs. Even just in one power generation unit, the coupling is complicated. For instance, the control of a DFIG-based wind turbine can be layered into three loops, including the active and reactive current control, dc-link voltage and terminal voltage control, and rotational speed control and reactive power control, of which the response time is ascending [71].

Some interaction issues have been exemplified in the literature. For example, due to the power exchange of the energy storage elements, there will be mutual effects among the current

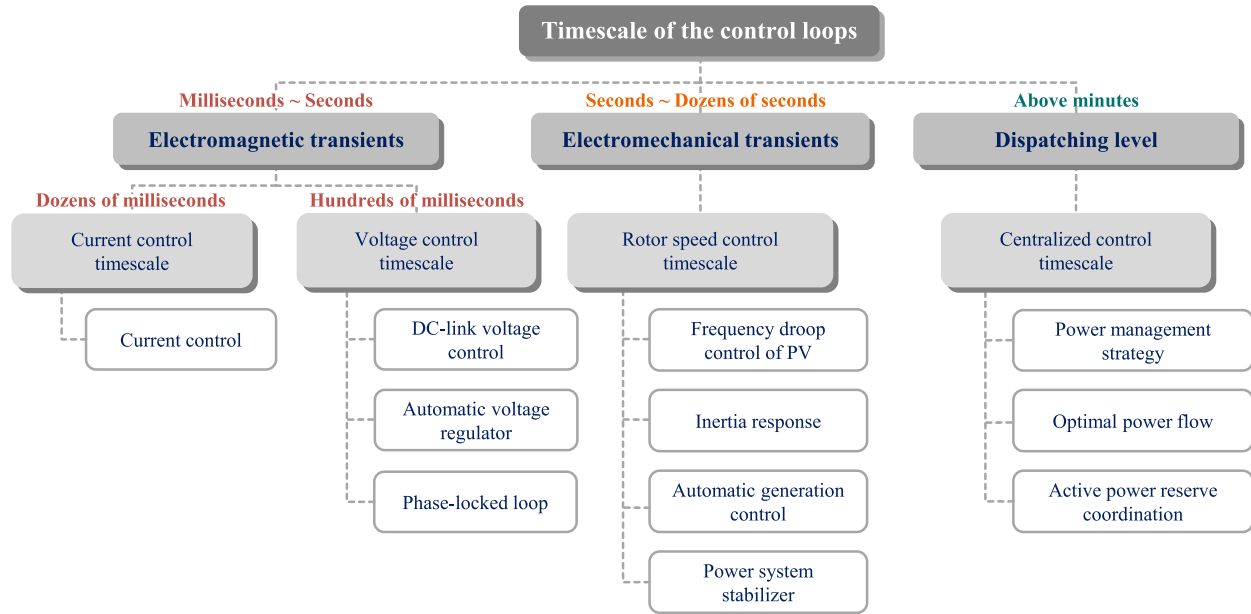

Fig. 5. Classification of the timescales of the control loops in PEDSSs.

controllers of the DFIG wind turbines, PV systems, and VSCs [79]. The interaction between direct-drive PMSGs and weak grids can cause negative-resistance effect to the system, which may trigger subsynchronous oscillations [93]. Furthermore, the rotational speed control of the wind turbine may affect the rotor motion of the SG, or the PSS operation [94].

### C. Central-Allocated Coordinated Control of Converters

As has been emphasized in the aforementioned, the power electronic converter owns high controllability and fast dynamics. Moreover, the output active power and reactive power of the power converter can be adjusted separately. All of these features make it possible to build up the converter to be a comprehensive control machine in charge of the tasks that are assigned to it. In such a case, the coordination of power converters, including the task assignment and controller performance requirement, becomes more vital.

The control of individual grid-connected power converters has been illustrated in Section II. The droop controls mentioned in Section II are generally decentralized, based on which the grid support can be effectively achieved. More specifically, the information of the neighboring area is collected for the droop control schemes, which then quickly regulate the converter outputs. This process can be an automatic coordinated control strategy, which effectively enhances the system stability [43]. However, in the PEDSSs, the coordination of power converters and other power devices cannot be ignored. That is to say, as there are multiple converters in the system, the role of each converter and the contribution of the converter to the grid should be assessed comprehensively. Moreover, the control parameters of the decentralized control, e.g., the droop control, should be set globally according to the stability assessment of the large-scale power system.

Much work has been done for the coordinated control strategy in microgrids considering the global system stability, which is known as the power sharing control [11]. The power sharing control is generally divided into three hierarchical layers, i.e., the primary control, secondary control, and tertiary control [95]. In the design of each layer, the global system stability should be considered. An example has been presented in [96], where the voltage droop control parameters are tuned by the optimal dc-power flow result from the secondary control layer.

The central-allocated coordinated control concept of converters can be referenced for the inertia support as well. For example, from the universal model of multiconverter systems shown in Section IV-A, the grid can collect the virtual inertia information from the converters conveniently. By solving the optimization problem based on the information, the allocation of the virtual inertia can be obtained. A similar concept has been proposed in [97], where it has been revealed that the disturbance location and the inertia placement in the grid are more crucial for the power system resilience, rather than the total inertia.

Moreover, supplementary plug-in controllers can be designed for more advanced control functions. For instance, for the power converter arranged to be as a low-frequency oscillation damper, the plug-in damping controllers can be installed to attenuate the oscillations [98]. The advantage of these so-called plug-in controllers compared to the main controller of the power converter lies in the high flexibility. More importantly, the added controllers should not affect the performance of the main controller and can be removed anytime when the function is no longer needed. In the future PEDSSs, the roles of power electronic converters will be much diversified, which may require supplementary controllers to enhance the system stability.

An example of the central-allocated coordinated control system is shown in Fig. 6, where the wind turbine, PV system,

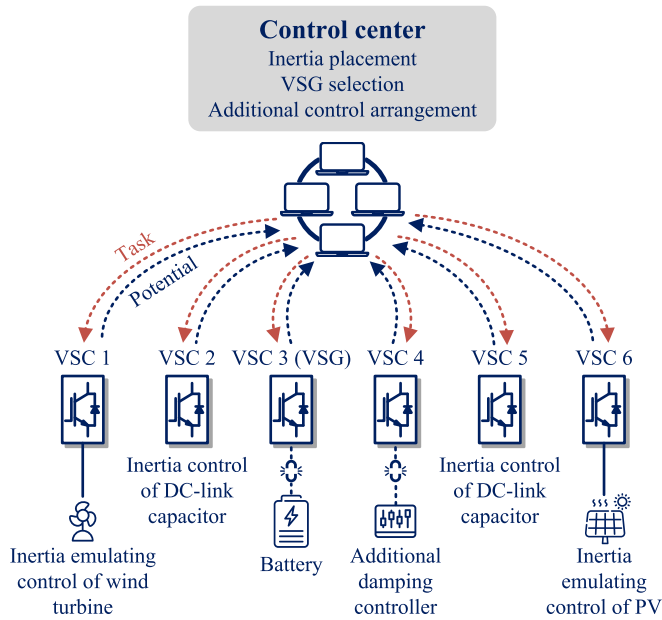

Fig. 6. Example of the central-allocated coordinated control system.

converter with a large-capacity ESS, and the regular grid-feeding converters are considered. In this example, all the converters update their control potential to the control center, e.g., the maximum inertia that they can emulate, and the additional control capability for particular emergencies such as low-frequency oscillations. Then, the control center will analyze the collected information to solve several issues, including the optimization of the virtual inertia placement, the VSG selection, and the additional control arrangement, etc. After that, the control center will send the task instruction to the converters to enable an optimized operation mode. For example, in Fig. 6, VSC 1, VSC 2, VSC 5, and VSC 6 are required to provide specified inertia, from the wind turbine, dc-link capacitors, and PV system, correspondingly. VSC 3 is selected to operate as a VSG with a large-capacity battery to support the system. VSC 4 is considered to be the best one to install the additional controller to damp oscillations in the system.

The stability issues and potential solutions for PEDSs are further summarized in Fig. 7. More specifically, the analysis and the subsequent development of potential solutions may consider these points in Fig. 7. In a summary, the high penetration of power converters makes the grid inertialess, complicated, and relatively vulnerable due to various dynamic features. Solutions should be developed to ensure the system stability, where all the aspects of the PEDSs may be considered essentially, as the system is highly cross coupled.

## V. CASE STUDY

In this section, a case study will be given to demonstrate the aforementioned discussion, where the interaction among the different control loops will be investigated as well. The case study system is shown in Fig. 8. It is constructed by a VSG and a grid-feeding inverter. Especially, in the grid-feeding

inverter, a frequency-dc-link voltage droop control loop is added to provide virtual inertia from the dc-link capacitor, as illustrated in Section III-B. The system parameters are given in Table II. In the steady state, the VSG supports the grid by controlling the grid frequency, and the inertia of the system is equivalent to the inertia coefficient of the VSG. The initial load is 2 kW, which is the same as the VSG rated power. For the grid-feeding inverter, its initial output power is 0, i.e., there is no power from the dc side, which benefits the analysis of the frequency support from the dc-link capacitor.

By adding a frequency-dc-link voltage droop control loop, the dc-link capacitor in the grid-feeding inverter can respond to the frequency deviation and regulate its output power to balance the deviation. As the charging and discharging processes contain a differential operator, which naturally emulates the swing equation of an SG, the virtual inertia can be provided. The detailed discussions are directed to [20].

### A. Virtual Inertia From the DC-Link Capacitor

In this case, a 10% load step (0.2 kW) is applied at  $t = 2$  s. When the frequency-dc-link voltage droop coefficient  $K_{wu}$  is set to 0, i.e., the frequency-dc-link voltage droop control is disabled, the dynamic of the inverter is shown in Fig. 9. Observations in Fig. 9 indicate that the output power of inverter remains almost unchanged (it is -0.02 kW in the steady state due to the inverter loss), which means that there is no inertia provided by the dc-link capacitor. In this case, the inertia of the entire system includes only the inertia of the VSG. After the load step, the grid frequency drops to 49.49 Hz, and slides to 49.92 Hz at the new steady state. When the frequency-dc-link voltage droop control is enabled by setting  $K_{wu}$  to be 24, the system dynamics are compared in Fig. 9. It can be seen in Fig. 9 that the inverter output power changes in response to the load step. In this case, the grid frequency drops to 49.63 Hz, and the new steady-state frequency is the same as 49.92 Hz. As the dc source of the inverter is set to be zero, the inverter output power is actually the power released by the dc-link capacitor. Thus, it is implied that the frequency-dc-link voltage droop control provides virtual inertia to the grid, which validates the discussion in Section III-B.

### B. Impact of Control Parameters on Virtual Inertia

Although the inertia response is in the rotor speed control timescale, the control loops in other timescales have impacts on it. For example, the PLL is in the current control timescale, but the parameters, e.g.,  $k_{kPLL}$ , will affect the system stability. For a certain  $K_{wu}$ , an inappropriate  $k_{kPLL}$  may lead to system instability. In such a case, the acceptable  $K_{wu}$  should be reduced, and the virtual inertia provided by the dc-link capacitor will, thereby, decrease. To validate this, the gain  $k_{kPLL}$  is increased from 100 to 200, and the load step is the same. The system responses when  $K_{wu} = 24$  are shown in Fig. 10. It can be seen in Fig. 10 that the increase of  $k_{kPLL}$  introduces high-frequency oscillations to the system, which is not desired. To avoid the oscillation,  $K_{wu}$  is reduced to 5, and the system dynamics are benchmarked in Fig. 10. It can be observed that the oscillation

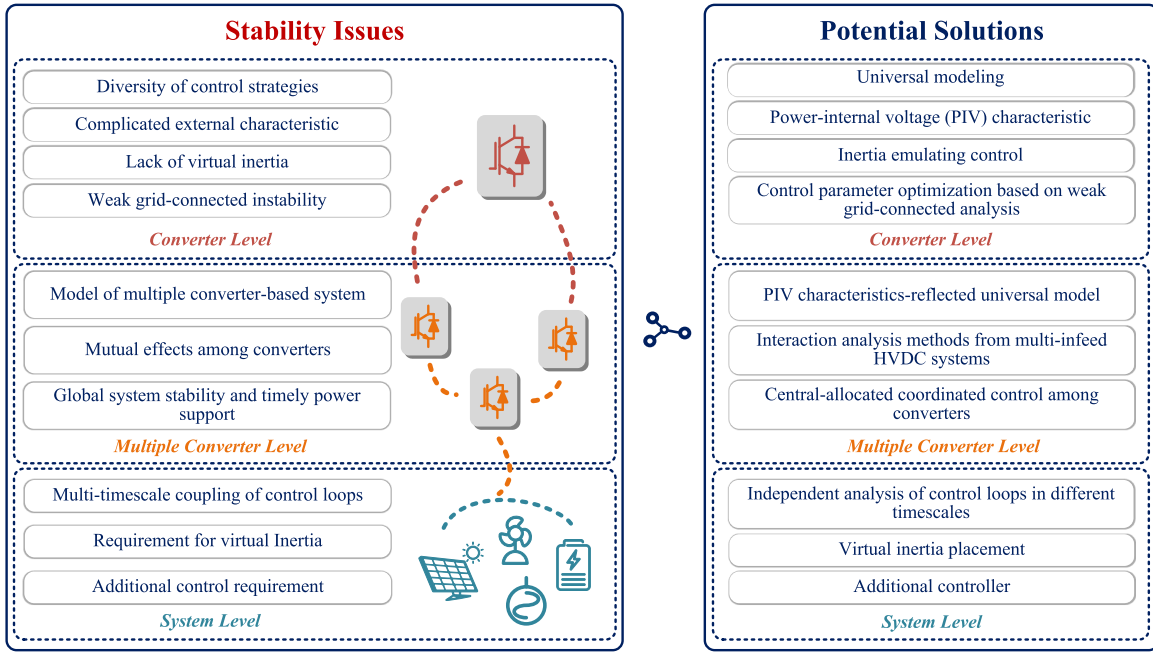

Fig. 7. General issues and future prospective research topics of PEDSs.

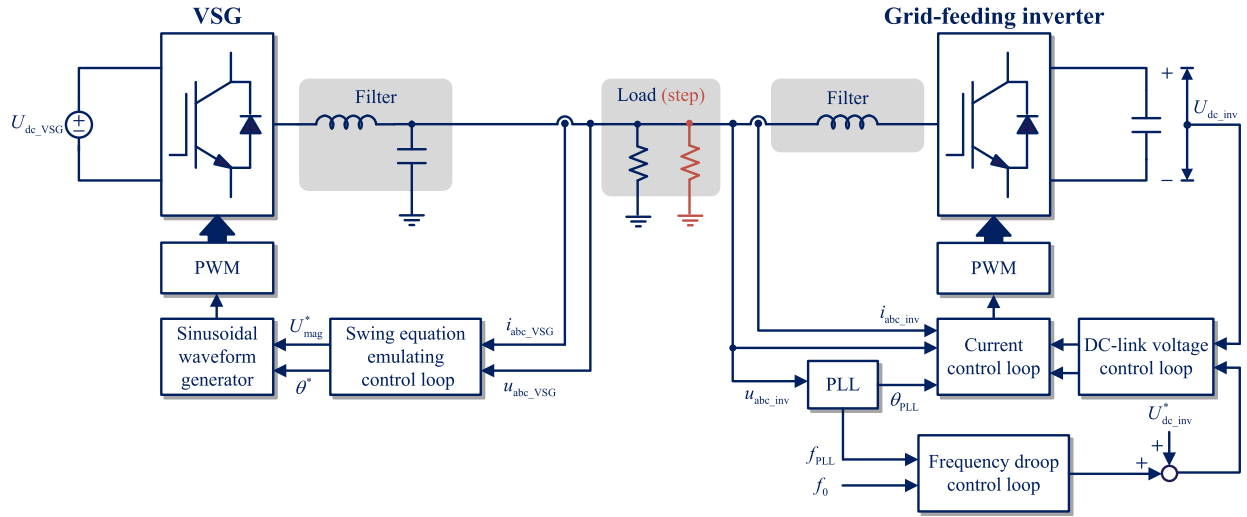

Fig. 8. Case study system including a VSG system and a grid-feeding inverter system.

TABLE II  
CASE STUDY SYSTEM PARAMETERS IN FIG. 8

VSG			Grid-feeding inverter		
Parameter	Description	Value	Parameter	Description	Value
$P_{\text{rated}}^{\text{VSG}}$	Rated power	2 kW	$P_{\text{rated}}^{\text{inv}}$	Rated power	0
$U_{\text{dc}}^{\text{VSG}}$	Rated DC-link voltage	800 V	$U_{\text{dc}}^{\text{inv}}$	Rated DC-link voltage	800 V
$R$	Frequency-power droop coefficient	0.005	$\Delta U_{\text{dc}}^{\text{max}}$	Maximum voltage deviation	$\pm 80$ V
$T_G$	Speed governor coefficient	0.1 s	$K_{wu}$	Frequency-DC-link voltage droop coefficient	24
$F_{\text{HP}}$	Turbine HP coefficient	0.3 s	$L_f$	Filter inductance	8 mH
$T_{\text{RH}}$	Reheater time constant	7.0 s	$C_{\text{dc}}$	DC-link capacitor	2.8 mF
$T_{\text{CH}}$	Main inlet volumes time constant	0.3 s	$(k_{\text{pdc}}, k_{\text{idc}})$	PI coefficients in the DC-link voltage controller	(0.5, 20)
$H$	Inertia constant	10 s	$(k_{\text{pi}}, k_{\text{ii}})$	PI coefficients in the current controller	(100, 1000)
$D$	Damping coefficient	1.0	$(k_{\text{pPLL}}, k_{\text{iPLL}})$	PI coefficients in the PLL	(100, 1000)
$f_0$	Rated frequency	50 Hz			

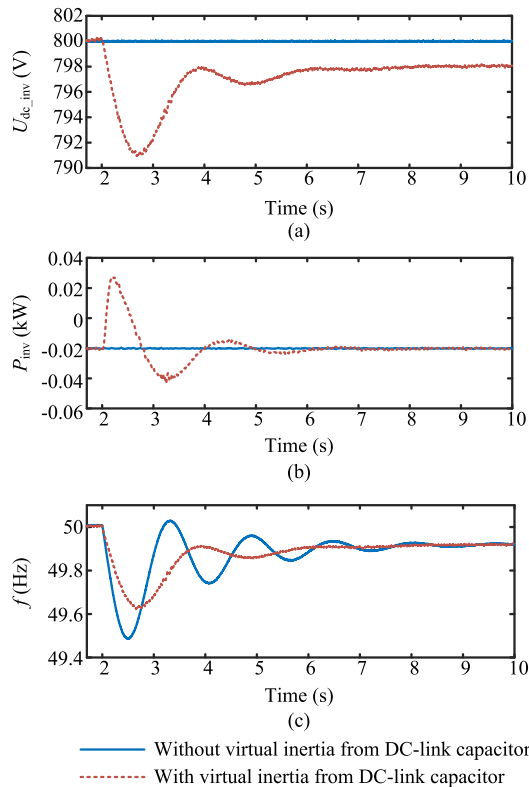

Fig. 9. Dynamic responses of the system shown in Fig. 8 under load changes without and with virtual inertia from the dc-link capacitor. (a) DC-link voltage. (b) Inverter output active power. (c) Grid frequency.

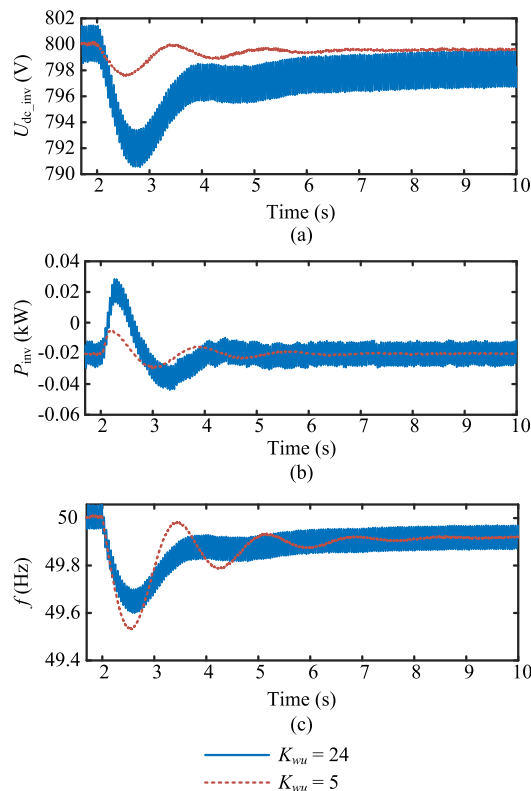

Fig. 10. Dynamic responses of the system shown in Fig. 8 under load changes with different  $K_{wu}$  when  $k_{kPLL} = 200$ . (a) DC-link voltage. (b) Inverter output active power. (c) Grid frequency.

is damped with the decreased gain  $K_{wu}$ , which yields reduced virtual inertia. It confirms that the virtual inertia provided by dc-link capacitors is not infinite; instead, it is limited by the control parameters and operating conditions. This case study provides evidence on the mutual effects among various control loops, as discussed in Section IV-B.

## VI. CONCLUSION

This article has discussed the stability issues of PEDSs. Specifically, the external characteristics, the complicated system inertia, and the severe weak grid issues of the grid-connected converters were discussed. It has been revealed that for the PEDSs, the stability issues may result from the multitime-scale coupling of control loops, and the mutual effect of converters and/or other power devices. In addition, the coordinated control among converters was briefed as a potential enhancement of the global system stability. A case study was presented in this article to demonstrate the inertia problem in PEDSs. It was shown that the dc-link capacitors in power converters could provide virtual inertia to the grid, which was constrained by control parameters and operating points of converters.

In conclusion, the future power grid with a high penetration level of power-electronics-based systems will become much inertialess. In that case, the inertia from power converters will play an important role in maintaining and enhancing the entire system stability. By then, the participation of power converters in the power system stability, such as their inertia contribution to the system, will be more visible and touchable. However, the boundary and concept of PEDSs are still relatively unclear, which also requires more standardization efforts. Nevertheless, an increasing number of power electronics in power systems can be foreseen, and thus, much more attention to the modeling and stability should be paid to enhance the system integration. Potential solutions summarized in this article may be considered to advance the power grid in terms of stability.

## REFERENCES

- [1] B. K. Bose, "Global energy scenario and impact of power electronics in 21st century," *IEEE Trans. Ind. Electron.*, vol. 60, no. 7, pp. 2638–2651, Jul. 2013.
- [2] F. Blaabjerg and K. Ma, "Wind energy systems," *Proc. IEEE*, vol. 105, no. 11, pp. 2116–2131, Nov. 2017.
- [3] Global Wind Energy Council, "Global Wind Report 2018," Global Wind Energy Council, Brussels, Belgium, Tech. Rep., Apr. 2019. [Online]. Available: <http://gwec.net/global-wind-report-2018/>
- [4] Solar Power Europe, "Global market outlook for solar power 2019-2023," Solar Power Europe, Brussels, Belgium, Tech. Rep., May 2019. [Online]. Available: <http://www.solarpowereurope.org/global-market-outlook-2019-2023/>
- [5] F. Blaabjerg, Y. Yang, D. Yang, and X. Wang, "Distributed power-generation systems and protection," *Proc. IEEE*, vol. 105, no. 7, pp. 1311–1331, Jul. 2017.
- [6] W. Wang and M. Barnes, "Power flow algorithms for multi-terminal VSC-HVDC with droop control," *IEEE Trans. Power Syst.*, vol. 29, no. 4, pp. 1721–1730, Jul. 2014.
- [7] Q. Xu, J. Xiao, X. Hu, P. Wang, and M. Y. Lee, "A decentralized power management strategy for hybrid energy storage system with autonomous bus voltage restoration and state-of-charge recovery," *IEEE Trans. Ind. Electron.*, vol. 64, no. 9, pp. 7098–7108, Sep. 2017.

- [8] A. Moawwad, E. F. El-Saadany, and M. S. El Moursi, "Dynamic security-constrained automatic generation control (AGC) of integrated AC/DC power networks," *IEEE Trans. Power Syst.*, vol. 33, no. 4, pp. 3875–3885, Jul. 2018.
- [9] Q. Peng, T. Liu, S. Wang, Y. Qiu, X. Li, and B. Li, "Determination of droop control coefficient of multi-terminal VSC-HVDC with system stability consideration," *IET Renew. Power Gener.*, vol. 12, no. 13, pp. 1508–1515, Oct. 2018.
- [10] D. E. Olivares *et al.*, "Trends in microgrid control," *IEEE Trans. Smart Grid*, vol. 5, no. 4, pp. 1905–1919, Jul. 2014.
- [11] H. Han, X. Hou, J. Yang, J. Wu, M. Su, and J. M. Guerrero, "Review of power sharing control strategies for islanding operation of AC microgrids," *IEEE Trans. Smart Grid*, vol. 7, no. 1, pp. 200–215, Jan. 2016.
- [12] X. Wang and F. Blaabjerg, "Harmonic stability in power electronic-based power systems: Concept, modeling, and analysis," *IEEE Trans. Smart Grid*, vol. 10, no. 3, pp. 2858–2870, May 2019.
- [13] X. Wang, F. Blaabjerg, and W. Wu, "Modeling and analysis of harmonic stability in an AC power-electronics-based power system," *IEEE Trans. Power Electron.*, vol. 29, no. 12, pp. 6421–6432, Dec. 2014.
- [14] M. Lu, Y. Yang, B. Johnson, and F. Blaabjerg, "An interaction-admittance model for multi-inverter grid-connected systems," *IEEE Trans. Power Electron.*, vol. 34, no. 8, pp. 7542–7557, Aug. 2019.
- [15] Q.-C. Zhong and G. Weiss, "Synchronverters: Inverters that mimic synchronous generators," *IEEE Trans. Ind. Electron.*, vol. 58, no. 4, pp. 1259–1267, Apr. 2011.
- [16] H. Wu *et al.*, "Small-signal modeling and parameters design for virtual synchronous generators," *IEEE Trans. Ind. Electron.*, vol. 63, no. 7, pp. 4292–4303, Jul. 2016.
- [17] J. Alipoor, Y. Miura, and T. Ise, "Power system stabilization using virtual synchronous generator with alternating moment of Inertia," *IEEE J. Emerg. Sel. Topics Power Electron.*, vol. 3, no. 2, pp. 451–458, Jun. 2015.
- [18] D. Li, Q. Zhu, S. Lin, and X. Y. Bian, "A self-adaptive inertia and damping combination control of VSG to support frequency stability," *IEEE Trans. Energy Convers.*, vol. 32, no. 1, pp. 397–398, Mar. 2017.
- [19] L. Huang *et al.*, "A virtual synchronous control for voltage-source converters utilizing dynamics of DC-link capacitor to realize self-synchronization," *IEEE J. Emerg. Sel. Topics Power Electron.*, vol. 5, no. 4, pp. 1565–1577, Dec. 2017.
- [20] J. Fang, H. Li, Y. Tang, and F. Blaabjerg, "Distributed power system virtual inertia implemented by grid-connected power converters," *IEEE Trans. Power Electron.*, vol. 33, no. 10, pp. 8488–8499, Oct. 2018.
- [21] Y. Huang, X. Yuan, J. Hu, and P. Zhou, "Modeling of VSC connected to weak grid for stability analysis of DC-link voltage control," *IEEE J. Emerg. Sel. Topics Power Electron.*, vol. 3, no. 4, pp. 1193–1204, Dec. 2015.
- [22] H. Yuan, X. Yuan, and J. Hu, "Modeling of grid-connected VSCs for power system small-signal stability analysis in DC-Link voltage control timescale," *IEEE Trans. Power Syst.*, vol. 32, no. 5, pp. 3981–3991, Sep. 2017.
- [23] Y. Huang, X. Zhai, J. Hu, D. Liu, and C. Lin, "Modeling and stability analysis of VSC internal voltage in DC-Link voltage control timescale," *IEEE J. Emerg. Sel. Topics Power Electron.*, vol. 6, no. 1, pp. 16–28, Mar. 2018.
- [24] Q. Peng, Y. Yang, H. Wang, and F. Blaabjerg, "On power electronic power systems: Challenges and solutions," in *Proc. IEEE Ind. Appl. Soc. Annu. Meet.*, Portland, OR, USA, Sep. 2018, pp. 1–9.
- [25] Q. Peng, J. Fang, Y. Yang, and F. Blaabjerg, "A universal model for grid-connected converters reflecting power-internal voltage characteristics," in *Proc. IEEE 4th Southern Power Electron. Conf.*, Singapore, Dec. 2018, pp. 1–7.
- [26] Q. Peng, Y. Yang, and F. Blaabjerg, "State-space modeling of grid-connected power converters considering power-internal voltage characteristics," in *Proc. 10th Int. Conf. Power Electron.-ECCE Asia*, May 2019, pp. 3047–3053.
- [27] S.-J. Park, F.-S. Kang, M. H. Lee, and C.-U. Kim, "A new single-phase five-level PWM inverter employing a deadbeat control scheme," *IEEE Trans. Power Electron.*, vol. 18, no. 3, pp. 831–843, May 2003.
- [28] J. Rodriguez and P. Cortes, *Predictive Control of Power Converters and Electrical Drives*, vol. 40. New York, NY, USA: Wiley, 2012.
- [29] S. Vazquez, J. Rodriguez, M. Rivera, L. G. Franquelo, and M. Norambuena, "Model predictive control for power converters and drives: Advances and trends," *IEEE Trans. Ind. Electron.*, vol. 64, no. 2, pp. 935–947, Feb. 2017.
- [30] T. Geyer and D. E. Quevedo, "Performance of multistep finite control set model predictive control for power electronics," *IEEE Trans. Power Electron.*, vol. 30, no. 3, pp. 1633–1644, Mar. 2015.
- [31] J. Liu, Y. Yin, W. Luo, S. Vazquez, L. G. Franquelo, and L. Wu, "Sliding mode control of a three-phase AC/DC voltage source converter under unknown load conditions: Industry applications," *IEEE Trans. Syst., Man, Cybern., Syst.*, vol. 48, no. 10, pp. 1771–1780, Oct. 2018.
- [32] X. Fu and S. Li, "Control of single-phase grid-connected converters with LCL filters using recurrent neural network and conventional control methods," *IEEE Trans. Power Electron.*, vol. 31, no. 7, pp. 5354–5364, Jul. 2016.
- [33] S. K. Sahoo, A. K. Sinha, and N. K. Kishore, "Control techniques in AC, DC, and hybrid AC-DC microgrid: A review," *IEEE J. Emerg. Sel. Topics Power Electron.*, vol. 6, no. 2, pp. 738–759, Jun. 2018.
- [34] J. Rocabert, A. Luna, F. Blaabjerg, and P. Rodríguez, "Control of power converters in AC microgrids," *IEEE Trans. Power Electron.*, vol. 27, no. 11, pp. 4734–4749, Nov. 2012.
- [35] S. Anand, S. K. Gundlapalli, and B. G. Fernandes, "Transformer-less grid feeding current source inverter for solar photovoltaic system," *IEEE Trans. Ind. Electron.*, vol. 61, no. 10, pp. 5334–5344, Oct. 2014.
- [36] A. A. A. Radwan and Y. A. I. Mohamed, "Power synchronization control for grid-connected current-source inverter-based photovoltaic systems," *IEEE Trans. Energy Convers.*, vol. 31, no. 3, pp. 1023–1036, Sep. 2016.
- [37] A. D. Paquette and D. M. Divan, "Virtual impedance current limiting for inverters in microgrids with synchronous generators," *IEEE Trans. Ind. Appl.*, vol. 51, no. 2, pp. 1630–1638, Mar. 2015.
- [38] T. An, G. Tang, and W. Wang, "Research and application on multi-terminal and DC grids based on VSC-HVDC technology in China," *High Voltage*, vol. 2, no. 1, pp. 1–10, 2017.
- [39] N. M. Kangwa, C. Venugopal, and I. E. Davidson, "A review of the performance of VSC-HVDC and MTDC systems," in *Proc. IEEE Power Energy Soc. PowerAfrica Conf.*, Accra, Ghana, Jun. 2017, pp. 267–273.
- [40] M. Callavik, P. Lundberg, and O. Hansson, "NORDLINK pioneering VSC-HVDC interconnector between Norway and Germany," *ABB White Paper*, Zurich, Switzerland, pp. 1–6, Mar. 2015.
- [41] F. Blaabjerg, R. Teodorescu, M. Liserre, and A. Timbus, "Overview of control and grid synchronization for distributed power generation systems," *IEEE Trans. Ind. Electron.*, vol. 53, no. 5, pp. 1398–1409, Oct. 2006.
- [42] R. Teodorescu, M. Liserre, and P. Rodríguez, *Grid Converters for Photovoltaic and Wind Power Systems*. Chichester, U.K.: Wiley, Jan. 2011.
- [43] Y. Sun, X. Hou, J. Yang, H. Han, M. Su, and J. M. Guerrero, "New perspectives on droop control in AC microgrid," *IEEE Trans. Ind. Electron.*, vol. 64, no. 7, pp. 5741–5745, Jul. 2017.
- [44] B. Li, T. Liu, and Y. Zhang, "Unified adaptive droop control design based on dynamic reactive power limiter in VSC-MTDC," *Elect. Power Syst. Res.*, vol. 148, pp. 18–26, Jul. 2017.
- [45] W. Wang, Y. Li, Y. Cao, U. Häger, and C. Rehtanz, "Adaptive droop control of VSC-MTDC system for frequency support and power sharing," *IEEE Trans. Power Syst.*, vol. 33, no. 2, pp. 1264–1274, Mar. 2018.
- [46] G.-C. Hsieh and J. C. Hung, "Phase-locked loop techniques. A survey," *IEEE Trans. Ind. Electron.*, vol. 43, no. 6, pp. 609–615, Dec. 1996.
- [47] F. Hans, W. Schumacher, and L. Harnefors, "Small-signal modeling of three-phase synchronous reference frame phase-locked loops," *IEEE Trans. Power Electron.*, vol. 33, no. 7, pp. 5556–5560, Jul. 2018.
- [48] S. Golestan and J. M. Guerrero, "Conventional synchronous reference frame phase-locked loop is an adaptive complex filter," *IEEE Trans. Ind. Electron.*, vol. 62, no. 3, pp. 1679–1682, Mar. 2015.
- [49] J. Fang, X. Li, H. Li, and Y. Tang, "Stability improvement for three-phase grid-connected converters through impedance reshaping in quadrature-axis," *IEEE Trans. Power Electron.*, vol. 33, no. 10, pp. 8365–8375, Oct. 2018.
- [50] P. Rodriguez, J. Pou, J. Bergas, J. I. Candela, R. P. Burgos, and D. Boroyevich, "Decoupled double synchronous reference frame PLL for power converters control," *IEEE Trans. Power Electron.*, vol. 22, no. 2, pp. 584–592, Mar. 2007.
- [51] P. Rodriguez, A. Luna, I. Candela, R. Mujal, R. Teodorescu, and F. Blaabjerg, "Multiresonant frequency-locked loop for grid synchronization of power converters under distorted grid conditions," *IEEE Trans. Ind. Electron.*, vol. 58, no. 1, pp. 127–138, Jan. 2011.
- [52] J. Sun, "Impedance-based stability criterion for grid-connected inverters," *IEEE Trans. Power Electron.*, vol. 26, no. 11, pp. 3075–3078, Nov. 2011.
- [53] M. Cespedes and J. Sun, "Impedance modeling and analysis of grid-connected voltage-source converters," *IEEE Trans. Power Electron.*, vol. 29, no. 3, pp. 1254–1261, Mar. 2014.
- [54] W. Cao, Y. Ma, and F. Wang, "Sequence-impedance-based harmonic stability analysis and controller parameter design of three-phase inverter-based multibus AC power systems," *IEEE Trans. Power Electron.*, vol. 32, no. 10, pp. 7674–7693, Oct. 2017.

- [55] X. Yue, X. Wang, and F. Blaabjerg, "Review of small-signal modeling methods including frequency-coupling dynamics of power converters," *IEEE Trans. Power Electron.*, vol. 34, no. 4, pp. 3313–3328, Apr. 2019.
- [56] Y. Wang, X. Wang, F. Blaabjerg, and Z. Chen, "Harmonic instability assessment using state-space modeling and participation analysis in inverter-fed power systems," *IEEE Trans. Ind. Electron.*, vol. 64, no. 1, pp. 806–816, Jan. 2017.
- [57] A. Singh, A. K. Kaviani, and B. Mirafzal, "On dynamic models and stability analysis of three-phase phasor PWM-Based CSI for stand-alone applications," *IEEE Trans. Ind. Electron.*, vol. 62, no. 5, pp. 2698–2707, May 2015.
- [58] N. Pogaku, M. Prodanović, and T. C. Green, "Modeling, analysis and testing of autonomous operation of an inverter-based microgrid," *IEEE Trans. Power Electron.*, vol. 22, no. 2, pp. 613–625, Mar. 2007.
- [59] A. Rodríguez-Cabero, M. Prodanovic, and J. Roldán-Pérez, "Analysis of dynamic properties of VSCs connected to weak grids including the effects of dead time and time delays," *IEEE Trans. Sustain. Energy*, vol. 10, no. 3, pp. 1066–1075, Jul. 2019.
- [60] P. Kundur, N. J. Balu, and M. G. Lauby, *Power System Stability and Control*. New York, NY, USA: McGraw-Hill, 1994.
- [61] P. Kessel and H. Glavitsch, "Estimating the voltage stability of a power system," *IEEE Trans. Power Del.*, vol. PWRD-1, no. 3, pp. 346–354, Jul. 1986.
- [62] J. Fang, H. Li, Y. Tang, and F. Blaabjerg, "On the inertia of future more-electronics power systems," *IEEE J. Emerg. Sel. Topics Power Electron.*, to be published, doi: [10.1109/JESTPE.2018.2877766](https://doi.org/10.1109/JESTPE.2018.2877766).
- [63] J. Liu, Y. Miura, H. Bevrani, and T. Ise, "Enhanced virtual synchronous generator control for parallel inverters in microgrids," *IEEE Trans. Smart Grid*, vol. 8, no. 5, pp. 2268–2277, Sep. 2017.
- [64] T. Shintai, Y. Miura, and T. Ise, "Oscillation damping of a distributed generator using a virtual synchronous generator," *IEEE Trans. Power Del.*, vol. 29, no. 2, pp. 668–676, Apr. 2014.
- [65] H. Bevrani, T. Ise, and Y. Miura, "Virtual synchronous generators: A survey and new perspectives," *Int. J. Elect. Power Energy Syst.*, vol. 54, no. 1, pp. 244–254, Jan. 2014.
- [66] Y. Huang, X. Yuan, J. Hu, P. Zhou, and D. Wang, "DC-Bus voltage control stability affected by AC-Bus voltage control in VSCs connected to weak AC grids," *IEEE J. Emerg. Sel. Topics Power Electron.*, vol. 4, no. 2, pp. 445–458, Jun. 2016.
- [67] J. Hu, J. Zhu, and M. Wan, "Modeling and analysis of modular multilevel converter in DC voltage control timescale," *IEEE Trans. Ind. Electron.*, vol. 66, no. 8, pp. 6449–6459, Aug. 2019.
- [68] M. F. M. Arani and E. F. El-Saadany, "Implementing virtual inertia in DFIG-based wind power generation," *IEEE Trans. Power Syst.*, vol. 28, no. 2, pp. 1373–1384, May 2013.
- [69] J. Hu, H. Yuan, and X. Yuan, "Modeling of DFIG-based WTs for small-signal stability analysis in DVC timescale in power electronic power systems," *IEEE Trans. Energy Convers.*, vol. 32, no. 3, pp. 1151–1165, Sep. 2017.
- [70] J. Zhao, X. Lyu, Y. Fu, X. Hu, and F. Li, "Coordinated microgrid frequency regulation based on DFIG variable coefficient using virtual inertia and primary frequency control," *IEEE Trans. Energy Convers.*, vol. 31, no. 3, pp. 833–845, Sep. 2016.
- [71] J. Ying, X. Yuan, J. Hu, and W. He, "Impact of inertia control of DFIG-Based WT on electromechanical oscillation damping of SG," *IEEE Trans. Power Syst.*, vol. 33, no. 3, pp. 3450–3459, May 2018.
- [72] N. Kakimoto, S. Takayama, H. Satoh, and K. Nakamura, "Power modulation of photovoltaic generator for frequency control of power system," *IEEE Trans. Energy Convers.*, vol. 24, no. 4, pp. 943–949, Dec. 2009.
- [73] X. Lyu, Z. Xu, J. Zhao, and K. P. Wong, "Advanced frequency support strategy of photovoltaic system considering changing working conditions," *IET Transmiss. Distrib. Gener.*, vol. 12, no. 2, pp. 363–370, 2018.
- [74] B. Crăciun, T. Kerekes, D. Séra, and R. Teodorescu, "Frequency support functions in large PV power plants with active power reserves," *IEEE J. Emerg. Sel. Topics Power Electron.*, vol. 2, no. 4, pp. 849–858, Dec. 2014.
- [75] H. Xin, Y. Liu, Z. Wang, D. Gan, and T. Yang, "A new frequency regulation strategy for photovoltaic systems without energy storage," *IEEE Trans. Sustain. Energy*, vol. 4, no. 4, pp. 985–993, Oct. 2013.
- [76] X. Huang, K. Wang, G. Li, and H. Zhang, "Virtual inertia-based control strategy of two-stage photovoltaic inverters for frequency support in islanded micro-grid," *Electronics*, vol. 7, no. 11, pp. 1–20, Nov. 2018.
- [77] J. Alipoor, Y. Miura, and T. Ise, "Stability assessment and optimization methods for microgrid with multiple VSG units," *IEEE Trans. Smart Grid*, vol. 9, no. 2, pp. 1462–1471, Mar. 2018.
- [78] L. Harnefors, M. Bongiorno, and S. Lundberg, "Input-admittance calculation and shaping for controlled voltage-source converters," *IEEE Trans. Ind. Electron.*, vol. 54, no. 6, pp. 3323–3334, Dec. 2007.
- [79] M. Zhao, X. Yuan, J. Hu, and Y. Yan, "Voltage dynamics of current control time-scale in a VSC-Connected weak grid," *IEEE Trans. Power Syst.*, vol. 31, no. 4, pp. 2925–2937, Jul. 2016.
- [80] Y. Li, C. Rehtanz, S. Ruberg, L. Luo, and Y. Cao, "Wide-area robust coordination approach of HVDC and FACTS controllers for damping multiple interarea oscillations," *IEEE Trans. Power Del.*, vol. 27, no. 3, pp. 1096–1105, Jul. 2012.
- [81] A. Fuchs, M. Imhof, T. Demiray, and M. Morari, "Stabilization of large power systems using VSC-HVDC and model predictive control," *IEEE Trans. Power Del.*, vol. 29, no. 1, pp. 480–488, Feb. 2014.
- [82] J. Xu, S. Xie, and T. Tang, "Evaluations of current control in weak grid case for grid-connected LCL-filtered inverter," *IET Power Electron.*, vol. 6, no. 2, pp. 227–234, Feb. 2013.
- [83] M. Liserre, R. Teodorescu, and F. Blaabjerg, "Stability of photovoltaic and wind turbine grid-connected inverters for a large set of grid impedance values," *IEEE Trans. Power Electron.*, vol. 21, no. 1, pp. 263–272, Jan. 2006.
- [84] J. Z. Zhou, H. Ding, S. Fan, Y. Zhang, and A. M. Gole, "Impact of short-circuit ratio and phase-locked-loop parameters on the small-signal behavior of a VSC-HVDC converter," *IEEE Trans. Power Del.*, vol. 29, no. 5, pp. 2287–2296, Oct. 2014.
- [85] J. Hu, B. Wang, W. Wang, H. Tang, Y. Chi, and Q. Hu, "Small signal dynamics of DFIG-Based wind turbines during riding through symmetrical faults in weak AC Grid," *IEEE Trans. Energy Convers.*, vol. 32, no. 2, pp. 720–730, Jun. 2017.
- [86] P. Zhou, X. Yuan, J. Hu, and Y. Huang, "Stability of DC-Link voltage as affected by phase locked loop in VSC when attached to weak grid," in *Proc. IEEE Power Energy Soc. Gen. Meet.*, Jul. 2014, pp. 1–5.
- [87] D. L. H. Aik and G. Andersson, "Analysis of voltage and power interactions in multi-infeed HVDC systems," *IEEE Trans. Power Del.*, vol. 28, no. 2, pp. 816–824, Apr. 2013.
- [88] CIGRÉ WG B4-41, "System with Multiple DC Infeed," CIGRÉ, Tech. Rep. ELT\_241\_6, Dec. 2008.
- [89] H. M. Hasanien, "Design optimization of PID controller in automatic voltage regulator system using Taguchi combined genetic algorithm method," *IEEE Syst. J.*, vol. 7, no. 4, pp. 825–831, Dec. 2013.
- [90] E. Rakhshani and P. Rodriguez, "Inertia emulation in AC/DC interconnected power systems using derivative technique considering frequency measurement effects," *IEEE Trans. Power Syst.*, vol. 32, no. 5, pp. 3338–3351, Sep. 2017.
- [91] R. T. Pinto, P. Bauer, S. F. Rodrigues, E. J. Wiggelinkhuizen, J. Pierik, and B. Ferreira, "A novel distributed direct-voltage control strategy for grid integration of offshore wind energy systems through MTDC network," *IEEE Trans. Ind. Electron.*, vol. 60, no. 6, pp. 2429–2441, Jun. 2013.
- [92] J. C. Hernández, P. G. Bueno, and F. Sanchez-Sutil, "Enhanced utility-scale photovoltaic units with frequency support functions and dynamic grid support for transmission systems," *IET Renew. Power Gener.*, vol. 11, no. 3, pp. 361–372, 2017.
- [93] H. Liu *et al.*, "Subsynchronous interaction between direct-drive PMSG based wind farms and weak AC networks," *IEEE Trans. Power Syst.*, vol. 32, no. 6, pp. 4708–4720, Nov. 2017.
- [94] G. Lalor, A. Mullane, and M. O'Malley, "Frequency control and wind turbine technologies," *IEEE Trans. Power Syst.*, vol. 20, no. 4, pp. 1905–1913, Nov. 2005.
- [95] J. M. Guerrero, J. C. Vasquez, J. Matas, L. G. de Vicuna, and M. Castilla, "Hierarchical control of droop-controlled AC and DC microgrids—A general approach toward standardization," *IEEE Trans. Ind. Electron.*, vol. 58, no. 1, pp. 158–172, Jan. 2011.
- [96] K. Rouzbehi, A. Miranian, A. Luna, and P. Rodriguez, "DC voltage control and power sharing in multiterminal DC grids based on optimal DC power flow and voltage-droop strategy," *IEEE J. Emerg. Sel. Topics Power Electron.*, vol. 2, no. 4, pp. 1171–1180, Dec. 2014.
- [97] B. K. Poolla, S. Bolognani, and F. Dorfler, "Optimal placement of virtual inertia in power grids," *IEEE Trans. Autom. Control*, vol. 62, no. 12, pp. 6209–6220, Dec. 2017.
- [98] R. Preece, J. V. Milanović, A. M. Almutairi, and O. Marjanovic, "Damping of inter-area oscillations in mixed AC/DC networks using WAMS based supplementary controller," *IEEE Trans. Power Syst.*, vol. 28, no. 2, pp. 1160–1169, May 2013.



**Qiao Peng** (S'18) received the B.Eng. degree in electrical engineering and automation from the College of Electrical Engineering, Sichuan University, Chengdu, China, in 2015. She is currently working toward the Ph.D. degree with Aalborg University, Aalborg, Denmark.

Her research interests include stability and control of power systems with renewable energies and power electronics, virtual inertia issues of grid-connected converters, and advanced control of PV systems.



**Qin Jiang** received the B.S. degree in electrical engineering and automation from Sichuan University, Chengdu, China, in 2016, where she is currently working toward the Ph.D. degree with the College of Electrical Engineering.

Her research interests include power system stability analysis and control, renewable energy, and high-voltage direct current transmission technology.



**Yongheng Yang** (SM'17) received the B.Eng. degree in electrical engineering and automation from Northwestern Polytechnical University, Shaanxi, China, in 2009, and the Ph.D. degree in electrical engineering from Aalborg University, Aalborg, Denmark, in 2014.

He was a Postgraduate Student with Southeast University, Nanjing, China, from 2009 to 2011. In 2013, he spent three months as a Visiting Scholar with Texas A&M University, College Station, TX, USA. He is currently an Associate Professor with the Department of Energy Technology, Aalborg University.

His current research interests include integration of grid-friendly photovoltaic systems with an emphasis on the power electronics converter design, control, and reliability.

Dr. Yang is the Chair of the IEEE Denmark Section. He serves as an Associate Editor for several prestigious journals, including the IEEE JOURNAL OF EMERGING AND SELECTED TOPICS IN POWER ELECTRONICS, the IEEE TRANSACTIONS ON INDUSTRIAL ELECTRONICS, and the IEEE TRANSACTIONS ON POWER ELECTRONICS. He is a Subject Editor for the *IET Renewable Power Generation* for Solar Photovoltaic Systems, including maximum power point tracking. He is the General Co-Chair of the 2020 IEEE International Future Energy Challenge and a Publicity Co-Chair of the 2020 IEEE Energy Conversion Congress and Exposition. He was the recipient of the 2018 IET Renewable Power Generation Premium Award and the IEEE TRANSACTIONS ON POWER ELECTRONICS' Outstanding Reviewer Award in 2018.



**Tianqi Liu** (SM'16) received the B.S. and the M.S. degrees from Sichuan University, Chengdu, China, in 1982 and 1986, respectively, and the Ph.D. degree from Chongqing University, Chongqing, China, in 1996, all in electrical engineering.

She is currently a Professor with the College of Electrical Engineering, Sichuan University. Her main research interests include power system analysis and stability control, HVDC, optimal operation, dynamic security analysis, and load forecast.



**Huai Wang** (M'12–SM'17) received the B.E. degree in electrical engineering from the Huazhong University of Science and Technology, Wuhan, China, in 2007, and the Ph.D. degree in power electronics from the City University of Hong Kong, Hong Kong, in 2012.

He is currently a Professor with the Center of Reliable Power Electronics, Department of Energy Technology, Aalborg University, Aalborg, Denmark. He was a Visiting Scientist with the ETH Zurich, Zurich, Switzerland, from August to September 2014, and with the Massachusetts Institute of Technology, Cambridge, MA, USA, from September to November 2013. He was with the ABB Corporate Research Center, Switzerland, in 2009. His research interests include the fundamental challenges in modeling and validation of power electronic component failure mechanisms, and application issues in system-level predictability, condition monitoring, circuit architecture, and robustness design.

Dr. Wang was the recipient of the Richard M. Bass Outstanding Young Power Electronics Engineer Award from the IEEE Power Electronics Society in 2016, and the Green Talents Award from the German Federal Ministry of Education and Research in 2014. He is currently the Chair of IEEE PELS/IAS/IES Chapter in Denmark. He serves as an Associate Editor for *IET Electronics Letters*, IEEE JOURNAL OF EMERGING AND SELECTED TOPICS IN POWER ELECTRONICS, and IEEE TRANSACTIONS ON POWER ELECTRONICS.



**Frede Blaabjerg** (S'86–M'88–SM'97–F'03) received the Ph.D. degree in electrical engineering from Aalborg University, Aalborg, Denmark, in 1995.

He was with ABB-Scandia, Randers, Denmark, from 1987 to 1988. He became an Assistant Professor in 1992, an Associate Professor in 1996, and a Full Professor of power electronics and drives in 1998, with Aalborg University, where in 2017, he became a Villum Investigator. He is honoris causa with the University Politehnica Timisoara, Timișoara, Romania and with Tallinn Technical University, Tallinn,

Estonia. His current research interests include power electronics and its applications such as in wind turbines, PV systems, reliability, harmonics, and adjustable speed drives. He has authored and coauthored more than 600 journal papers in the fields of power electronics and its applications. He is the Co-Author of four monographs and an Editor of ten books in power electronics and its applications.

Dr. Blaabjerg was the recipient of 31 IEEE Prize Paper Awards, the IEEE Power Electronics Society Distinguished Service Award in 2009, the EPE-PEMC Council Award in 2010, the IEEE William E. Newell Power Electronics Award 2014, the Villum Kann Rasmussen Research Award 2014, and the Global Energy Prize in 2019. He was the Editor-in-Chief for the IEEE TRANSACTIONS ON POWER ELECTRONICS from 2006 to 2012. He has been a Distinguished Lecturer for the IEEE Power Electronics Society from 2005 to 2007 and for the IEEE Industry Applications Society from 2010 to 2011 as well as 2017 to 2018. In 2019–2020 he serves a President for the IEEE Power Electronics Society. He is the Vice-President of the Danish Academy of Technical Sciences.