



Fast amplitude estimation for Low-Voltage Ride-Through Operation of Single-Phase Systems

Zhang, Juxiang; Zhao, Peiqi; Zhang, Zhen; Yang, Y.; Blaabjerg, F.; Dai, Zhiyong

Published in:
IEEE Access

DOI (link to publication from Publisher):
[10.1109/ACCESS.2019.2963226](https://doi.org/10.1109/ACCESS.2019.2963226)

Creative Commons License
CC BY 4.0

Publication date:
2020

Document Version
Publisher's PDF, also known as Version of record

[Link to publication from Aalborg University](#)

Citation for published version (APA):
Zhang, J., Zhao, P., Zhang, Z., Yang, Y., Blaabjerg, F., & Dai, Z. (2020). Fast amplitude estimation for Low-Voltage Ride-Through Operation of Single-Phase Systems. *IEEE Access*, 8, 8477-8484. Article 8946577. <https://doi.org/10.1109/ACCESS.2019.2963226>

General rights

Copyright and moral rights for the publications made accessible in the public portal are retained by the authors and/or other copyright owners and it is a condition of accessing publications that users recognise and abide by the legal requirements associated with these rights.

- Users may download and print one copy of any publication from the public portal for the purpose of private study or research.
- You may not further distribute the material or use it for any profit-making activity or commercial gain
- You may freely distribute the URL identifying the publication in the public portal -

Take down policy

If you believe that this document breaches copyright please contact us at vbn@aub.aau.dk providing details, and we will remove access to the work immediately and investigate your claim.

Received December 11, 2019, accepted December 26, 2019, date of publication December 31, 2019, date of current version January 15, 2020.

Digital Object Identifier 10.1109/ACCESS.2019.2963226

Fast Amplitude Estimation for Low-Voltage Ride-Through Operation of Single-Phase Systems

JUXIANG ZHANG¹, PEIQI ZHAO¹, ZHEN ZHANG²,
YONGHENG YANG³, (Senior Member, IEEE),
FREDE BLAABJERG³, (Fellow, IEEE), AND ZHIYONG DAI¹

¹School of Mechano-Electronic Engineering, Xidian University, Xi'an 710071, China

²School of Electronic and Control Engineering, Chang'an University, Xi'an 710064, China

³Department of Energy Technology, Aalborg University, 9220 Aalborg, Denmark

Correspondence: Zhen Zhang (zhenzhang@chd.edu.cn)

This work was supported in part by the NSF of China under Grant 51707140, in part by the NSF of Shaanxi Province under Grant 2018JQ5061, and in part by the Fundamental Research Funds for Central Universities under Grant JBX170416 and Grant XJS17037.

ABSTRACT Estimating the amplitude of the grid voltage is important for low-voltage ride-through (LVRT) operation in single-phase systems. It requires fast dynamics and is typically achieved through a phase-locked loop (PLL). This paper proposes a fast amplitude estimation (FAE) method without a PLL structure. The grid voltage is formulated as a vector sum of sine and cosine functions, resulting in an algebraic model with two unknown parameters. The proposed FAE identifies the two parameters, and thus achieving a fast fault detection (i.e., the amplitude estimation). Experimental results verify the performance of the proposed method in terms of fast dynamics.

INDEX TERMS Amplitude estimation, voltage sags, low-voltage ride-through (LVRT), parameter identification, single-phase systems, grid synchronization.

I. INTRODUCTION

In recent years, renewable energy sources, e.g., wind and photovoltaic (PV) power, have become essential in the grid modernization. However, the intermittent and non-dispatchable nature of the renewable energy challenges the grid stability [1], [2]. To enhance the resilience and robustness of power systems, grid codes are released to guide the integration of renewable energy [3]–[5]. For instance, it is now mandatory for grid-connected units to ride through temporary low-voltage grid faults, known as the low-voltage ride-through (LVRT) operation. In the LVRT operation, the generation units may provide dynamic grid support by injecting reactive currents as many grid codes requirements [6]. Taking the Chinese grid code for PV as an example, the voltage profile and the corresponding reactive current requirement are shown in Fig. 1 [6]. It can be observed in Fig. 1(a) that in certain cases the generation units have to remain connected, even when the grid voltage drops to zero volts for a period up to 150 ms. The grid codes also define that the amount of the reactive current injected into the grids should change with the

curve in Fig. 1(b) during LVRT. Meanwhile, the injection of the reactive current should be as fast as possible, since the required reactive power should be delivered into the grids through the PV generator within 30 ms. Thus, in order to ensure the stable operation of the grid-tied system, it is necessary to apply a fast fault detection method to the grid converter system. In details, the grid voltage amplitude should be estimated quickly so that the grid-tied inverter has sufficient time to response during fault periods [7].

There are many methods reported in the literature to estimate the grid voltage amplitude such as the root mean square (RMS) method [8], the peak voltage detection method [9] and the discrete Fourier transform (DFT) method [10]–[12]. However, the dynamics of above methods are slow. Both the RMS- and the DFT-based methods have at least one cycle time delay, and the solution based on the peak voltage detection results in at least one half cycle time delay. Alternatively, PLL-based methods, e.g., using the dq-transformation [13], the delayed signal cancellation-PLL (DSC-PLL) [14], [15] and the active power filter-PLL (APF-PLL) methods [16] can provide an estimate of the grid voltage amplitude. However, when the grid voltage suffers from the harmonic distortion, its detection performance will

The associate editor coordinating the review of this manuscript and approving it for publication was Fengjiang Wu¹.

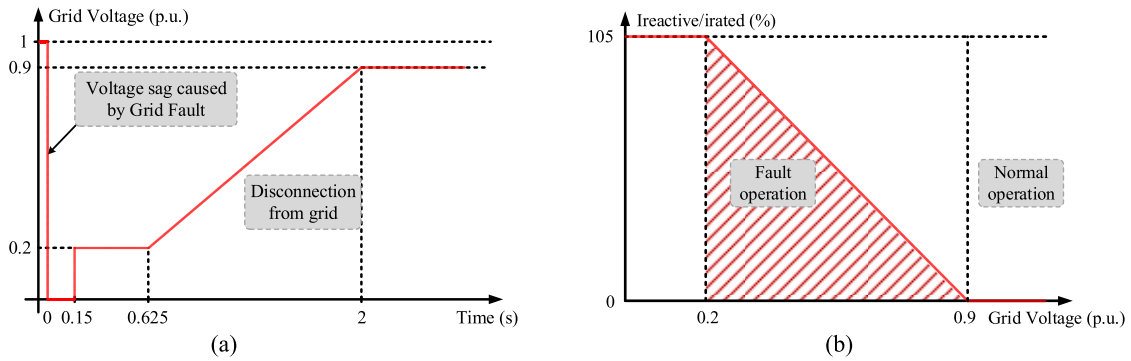

FIGURE 1. Low-voltage ride-through requirements in the Chinese grid code: (a) voltage profiles and (b) reactive current injection during the operation [4].

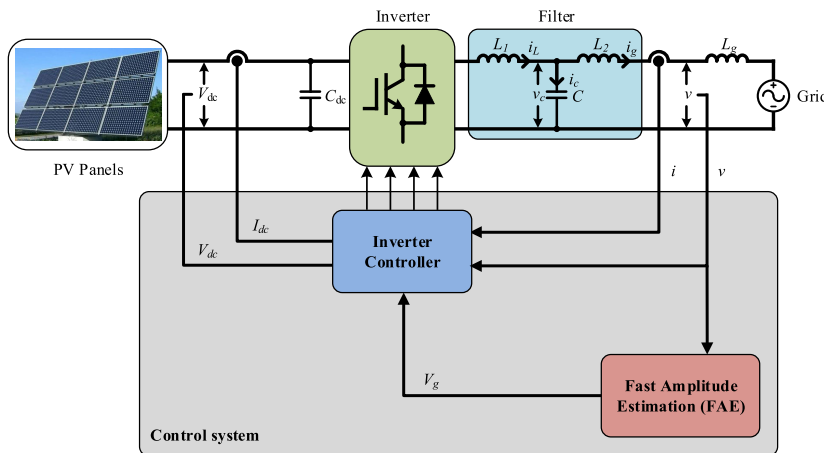

FIGURE 2. Control scheme of LVRT operation.

be degraded. To tackle this issue, the second-order generalized integration (SOGI-PLL) method [17]–[20] has been proposed. It is one of the most popular method among voltage detection because of its simple structure and good harmonic immunity. The enhanced PLL (EPLL) is another popular method in single-phase applications. The standard EPLL can track phase and frequency jumps without steady-state error. However, there will be a steady-state error in the presence of the frequency drifts [21]. In [22], an improved EPLL by adding multiple delayed signal cancellation filters has been proposed to tackle this problem. However, this EPLL have slow dynamics due to the filters. Meanwhile, there are several methods embed a digital filter into the PLLs to eliminate the harmonic components [23]–[26], such as the moving average filter based-PLL (MAF-PLL) method and the cascaded delayed signal cancellation based-PLL (CDSC-PLL) method. All the methods mentioned above has a good suppression effect on harmonics. Nevertheless, slow dynamics are associated with the PLLs, the settling time of these PLL-based methods usually lasts for one grid cycle, and hence, the entire LVRT performance is degraded.

In addition, in order to get the fast estimation of grid voltage amplitude during LVRT, there are some amplitude estimation methods with pre-filtering stage to deal with the harmonics and independent of PLL. For example, the method

in [3] achieves the accurate detection under harmonic conditions and its response time depends on the voltage variation point. On the basis of the delay signal cancellation (DSC) [27], [28] module, the cascaded DSC (CDSC) module [29] is designed as another non-PLL technique for voltage amplitude estimation, which benefits from the fast dynamic response and the strong harmonic suppression ability. Another DSC operator is used to reduce the response time. In addition, [30] proposed an adaptive observer to estimate the voltage amplitude with fast dynamics. However, the main shortcoming of the non-PLL methods is that the performance will be degraded seriously when the grid voltage suffers from the frequency variation.

In this paper, a fast amplitude estimation (FAE) method is proposed for single-phase systems to enhance the LVRT operation. The proposed FAE takes the grid voltage as a vector sum of standard sine and cosine functions. Subsequently, an algebraic model is established based on the measured grid voltage, the sine and cosine functions, and two unknown parameters related to the grid voltage amplitude and the phase angle. Furthermore, a parameter identification method is introduced to identify the unknown parameters of the established model, resulting in the estimation of the voltage amplitude. It is worth to mention that the proposed FAE does not rely on PLLs and achieves fast dynamics. Experimental

results also confirm the fast dynamics of the proposed method in Section IV.

II. THE CONTROL SYSTEM OF LVRT OPERATION

In Fig. 2, it shows the control scheme of LVRT operation to illustrate the function of the proposed FAE method in LVRT. The main structure consists of an inverter and its controller. According to the filtered voltage signal from the AC side of the inverter, the FAE method calculates the voltage amplitude and provides real-time information to the inverter controller. Meanwhile, the inverter controller asks the inverter to deliver the reactive power to the grids according to the amplitude information given by the FAE.

III. PROPOSED AMPLITUDE ESTIMATION METHOD

In single-phase systems, the grid voltage can be given by

$$v(t) = V_g \sin(\omega t + \phi) = V_g \sin \varphi \quad (1)$$

where $v(t)$ is the grid voltage, V_g , ω , ϕ and φ are the amplitude, frequency, initial phase angle and phase angle of the grid voltage respectively. Expanding (1) yields

$$\begin{aligned} v(t) &= V_g \cos \phi \sin \omega t + V_g \sin \phi \cos \omega t \\ &= a \sin \omega t + b \cos \omega t \end{aligned} \quad (2)$$

in which a and b are two unknown parameters as

$$a = V_g \cos \phi \quad (3)$$

$$b = V_g \sin \phi \quad (4)$$

Clearly, when a and b are known, the relationship between a and b indicates that the voltage amplitude can be obtained as

$$V_g = \sqrt{a^2 + b^2} \quad (5)$$

However, the parameters a and b in (2) are unknown. In the following, a and b are estimated, and the grid voltage amplitude is then calculated by (5).

For the grid voltage shown in (1), the estimated voltage can be expressed as

$$\hat{v}(t) = \hat{a}(t) \sin \omega t + \hat{b}(t) \cos \omega t \quad (6)$$

Accordingly, the error between the measured grid voltage and the estimation can be defined as

$$\varepsilon(t) = \hat{a}(t) \sin \omega t + \hat{b}(t) \cos \omega t - v(t) \quad (7)$$

$\varepsilon(t)$ represents the error between the estimation value and the actual value. \hat{a} and \hat{b} being the estimated values of a and b , respectively. With (7), the parameter estimators of a and b are proposed as

$$\dot{\hat{a}}(t) = -\gamma \varepsilon(t) \sin \omega t \quad (8)$$

$$\dot{\hat{b}}(t) = -\gamma \varepsilon(t) \cos \omega t \quad (9)$$

in which γ is the designed parameter of the proposed estimators and $\gamma > 0$. In the following, a mathematical analysis is presented to demonstrate that the proposed estimators in

(7)-(9) can achieve zero steady-state error estimation of the unknown parameters, a and b .

For simplicity, the estimation errors are further defined as

$$\tilde{a}(t) = \hat{a}(t) - a \quad (10)$$

$$\tilde{b}(t) = \hat{b}(t) - b \quad (11)$$

Substituting (2) into (7) and considering (10) and (11), we obtain

$$\begin{aligned} \varepsilon(t) &= \hat{a}(t) \sin \omega t + \hat{b}(t) \cos \omega t - a \sin \omega t - b \cos \omega t \\ &= \tilde{a}(t) \sin \omega t + \tilde{b}(t) \cos \omega t \end{aligned} \quad (12)$$

A Lyapunov function is then defined as

$$V(t) = \frac{\tilde{a}^2(t) + \tilde{b}^2(t)}{2} \quad (13)$$

Subsequently, taking the derivative of Lyapunov function (14) yields

$$\dot{V}(t) = \tilde{a}(t) \dot{\tilde{a}}(t) + \tilde{b}(t) \dot{\tilde{b}}(t) \quad (14)$$

From (10) and (11), we have

$$\dot{\tilde{a}}(t) = \dot{\hat{a}}(t) = -\gamma \varepsilon(t) \sin \omega t \quad (15)$$

$$\dot{\tilde{b}}(t) = \dot{\hat{b}}(t) = -\gamma \varepsilon(t) \cos \omega t \quad (16)$$

Then, substituting (15) and (16) into (14) and together with (12), it results in

$$\begin{aligned} \dot{V}(t) &= -\tilde{a}(t) \gamma \varepsilon(t) \sin \omega t + \tilde{b}(t) \gamma \varepsilon(t) \cos \omega t \\ &= -\gamma \left(\tilde{a}(t) \sin \omega t + \tilde{b}(t) \cos \omega t \right) \varepsilon(t) \\ &= -\gamma \varepsilon(t)^2 \end{aligned} \quad (17)$$

Since $\gamma > 0$, the following holds

$$\dot{V}(t) \leq 0 \quad (18)$$

Considering that $\sin \omega t$ and $\cos \omega t$ are persistently exciting and also according to the adaptive control theory [31], it can be concluded that

$$\lim_{t \rightarrow \infty} \hat{a} = a \quad (19)$$

$$\lim_{t \rightarrow \infty} \hat{b} = b \quad (20)$$

This means that the proposed method in (7)-(9) can estimate the unknown parameters a and b with zero steady-state error. In addition, the proposed controller ensures that the estimated quantities converge to zero exponentially, which has been proved in [31]. Accordingly, with the obtained a and b , the amplitude of the grid voltage is estimated as

$$\hat{V}_g = \sqrt{\hat{a}^2 + \hat{b}^2} \quad (21)$$

where \hat{V}_g is the estimation of V_g .

In summary, the proposed FAE can estimate the grid voltage amplitude, following (7)-(9) and (21). To give a more clear explanation of the proposed FAE, the control structure of the FAE method (7)-(9) and (21) is shown in Fig. 3. Moreover, the selection of the parameter γ is important for

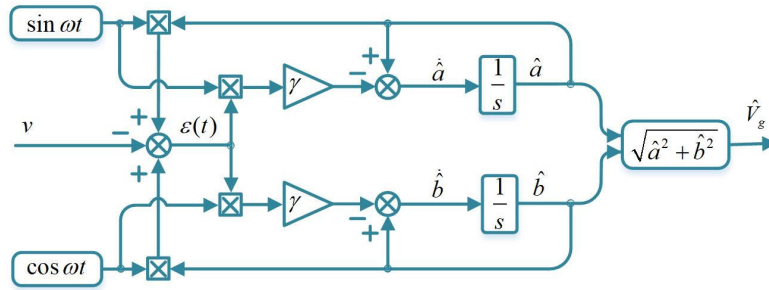

FIGURE 3. Proposed method for the amplitude estimation of the single-phase grid voltage.

TABLE 1. Steady-state performance under different values of γ .

The value of γ	Estimation error (p.u.)
0.04	0.012
0.05	0.017
0.06	0.019
0.07	0.018
0.08	0.021
0.09	0.020
1.0	0.023

TABLE 2. Estimation error under different frequency deviation.

Frequency deviation (Hz)	Estimation error (p.u.)
± 0.1	± 0.001
± 0.3	± 0.004
± 0.5	± 0.007

the performance of the proposed FAE. To discuss the relationships between the chosen parameter γ and the performance of the proposed method, FAE is tested with different γ under a voltage drop from 1 p.u. to 0.4 p.u. and the results are shown in Fig. 4. It is observed from Fig. 4 that a large γ results in a small fall time. However, too large γ will cause an overshoot and its settling time will slow down, as shown in the case of $\gamma = 0.1$. Meanwhile, the proposed method FAE is also tested with different values of γ under harmonic distortion, which contains the fifth- and seventh-order harmonic disturbances of 0.03 p.u. and 0.01 p.u., respectively. The simulation results are shown in TABLE 1. It can be observed that a large γ results in large estimation error. Above all, $\gamma = 0.07$ is the best choice for both dynamic and steady-state performance of FAE.

In addition, it should be pointed out that the proposed FAE requires the grid frequency information for generating the functions, $\sin \omega kT_s$ and $\cos \omega kT_s$, which can be obtained by a

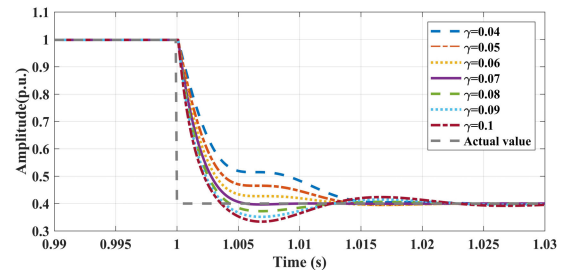

FIGURE 4. Performance comparison of the proposed fast amplitude estimation (FAE) under different values of γ .

frequency-locked loop. However, to maintain the dynamics of the proposed method, the frequency for $\sin \omega kT_s$ and $\cos \omega kT_s$ in this paper is set as the grid nominal frequency, while the robustness against the frequency jump is still high due to the adaptive scheme in the proposed method, which will be confirmed by the experimental results in the next section.

IV. EXPERIMENT RESULTS

In this section, experimental tests are performed to verify the effectiveness of the proposed FAE. The parameters of the proposed FAE are chosen as $\gamma = 0.07$, and the nominal frequency is 50 Hz. The sampling frequency is 10 kHz. Meanwhile, the estimation achieved by the SOGI-PLL [12] system is also compared through experimental tests. The parameters of SOGI-PLL are set as $k_p = 92$ and $k_i = 4232$. Similar with the setup in [33] and [34], Fig. 5 shows the hardware implementation of the experimental platform for the proposed method, which is based on a digital signal processor (DSP) TMS320F28335. The voltage sag is generated by an ac power generator, the grid amplitude is calculated by a DSP-based controller, and the detection results are displayed by an oscilloscope.

Case 1: Fig. 6 shows the experimental results under a voltage drop of 0.6 p.u.. It can be observed in Fig. 6 that the proposed FAE method can estimate the amplitude of the grid voltage with zero steady-state error, and its settling time is less than 5 ms. When compared to the estimations by the SOGI-PLL, the proposed method has faster dynamics, as shown in Fig. 6.

TABLE 3. Comparison with different methods.

Detection method	Settling time without harmonics (ms)	Settling time with harmonics (ms)	Estimation error under harmonic distortion
CDSC-PLL [22]	9.5	9.5	1.16%
APF-PLL [16]	6.5	--*	13.3%
Adaptive observer [28]	5.6	--*	11.3%
Proposed method	4	3.9	3.7%

*The steady-state errors of the APF-PLL and the adaptive observer [20] are larger than 5% under harmonic distortion. Hence, they have no settling time shown in Table II according to 5% criterion.

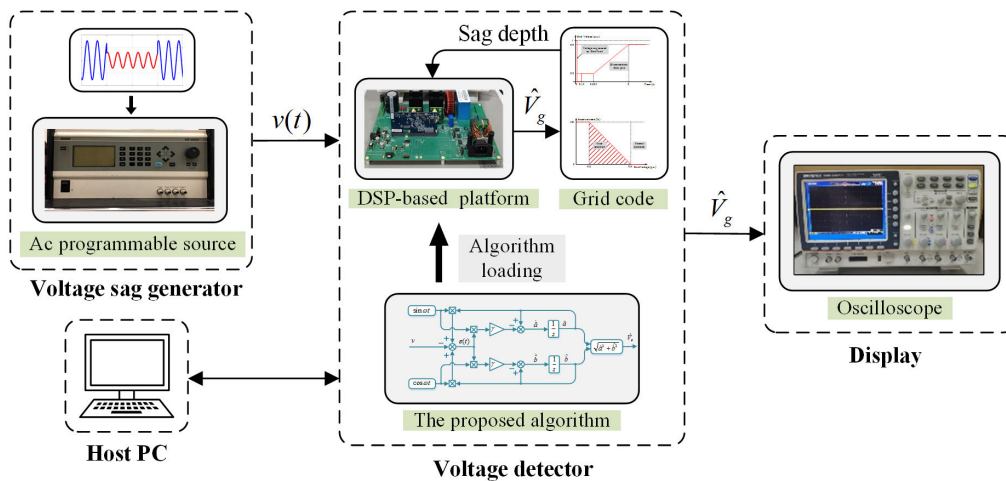

FIGURE 5. Experimental setup.

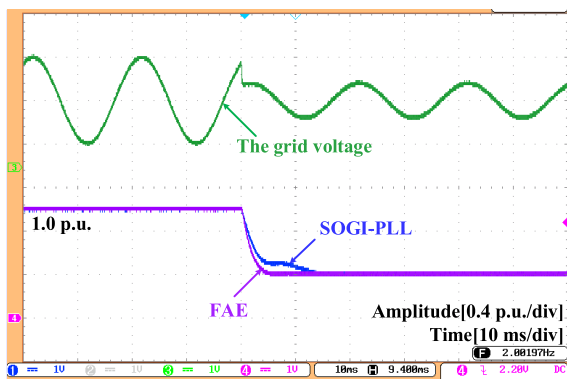

FIGURE 6. Performance comparison of the proposed fast amplitude estimation (FAE) and the estimation by the SOGI-PLL under a voltage drop of 0.6 p.u.

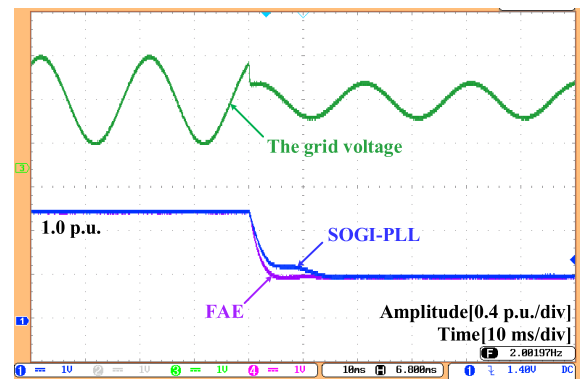

FIGURE 7. Performance comparison of the proposed fast amplitude estimation (FAE) and the estimation by the SOGI-PLL in the case of a voltage sag of 0.6 p.u. and a frequency jump of 1 Hz.

Case 2: Fig. 7 compares the performance of the proposed method and the SOGI-PLL method in the case of a grid disturbance with a voltage sag of 0.6 p.u. and a frequency jump of 1 Hz. As shown in Fig. 7, the proposed FAE method can accurately estimate the amplitude of the grid voltage. Further observations from Fig. 7 indicate that the proposed FAE method has fast dynamics and also high robustness

against frequency jumps even the nominal frequency was adopted (as discussed in Section III).

To further verify the robustness against frequency jump, the proposed method is tested under different frequency deviations. According to the grid code [32] on frequency deviation of power systems, the frequency jumps are limited in ± 0.5 Hz. Hence, the proposed method is further tested

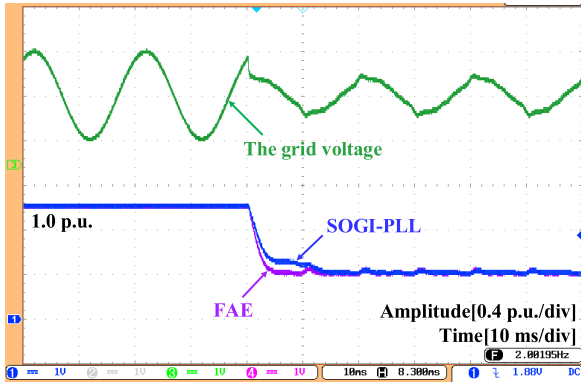

FIGURE 8. Performance comparison of the proposed fast amplitude estimation (FAE) and the estimation by the SOGI-PLL under a voltage drop of 0.6 p.u., where the grid voltage also contains 5% 3rd, 6% 5th, 5% 7th, 1.5% 9th and 3.5% 11th-order harmonics respectively.

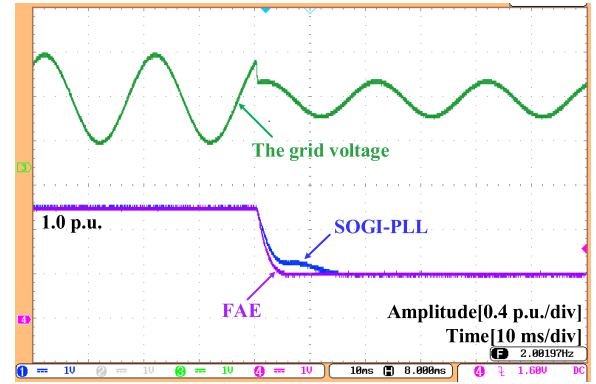

FIGURE 10. Performance comparison of the proposed fast amplitude estimation (FAE) and the estimation by the SOGI-PLL under the noise disturbances and a voltage drop of 0.6 p.u.

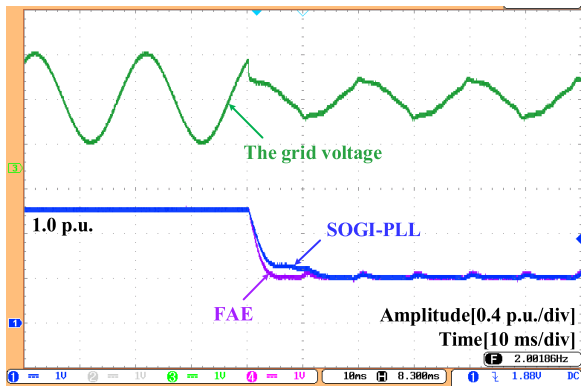

FIGURE 9. Performance comparison of the proposed fast amplitude estimation (FAE) and the estimation by the SOGI-PLL in the case of a voltage sag of 0.6 p.u. where the grid voltage also contains 5% 3rd, 6% 5th, 5% 7th, 1.5% 9th and 3.5% 11th-order harmonics respectively and a frequency jump of 1 Hz.

under different frequency deviations ($\leq 0.5\text{Hz}$). The results are shown in TABLE 2. The maximum estimation error is $\pm 0.7\%$ p.u.. It shows the proposed method has good robustness against frequency jump.

Case 3: In addition, the two estimation methods are tested under harmonics. Fig. 8 shows the experimental results under a voltage drop of 0.6 p.u. in the grid voltage, which also contains the 5% 3rd, 6% 5th, 5% 7th, 1.5% 9th and 3.5% 11th-order harmonics respectively. In this case, the proposed method again can estimate the amplitude of the distorted grid voltage with fast dynamics. Moreover, the harmonic attenuation capability of the proposed method is the same as that of the SOGI-PLL.

Case 4: In this case, the two methods are conducted under a voltage drop of 0.6 p.u. in the grid voltage, which also contains the 5% 3rd, 6% 5th, 5% 7th, 1.5% 9th and 3.5% 11th-order harmonics as well as 1 Hz frequency jump. The experiment results are shown in Fig. 9. It is obvious that the FAE and the SOGI-PLL methods both have a slight fluctuation in the amplitude estimation. However, the settling time of the SOGI-PLL method is longer than that of the FAE method.

Case 5: In order to verify the noise robustness of the proposed method, the experiment results under noise disturbances are shown in Fig. 10. From Fig. 10, it is seen that the steady-state performance of FAE is as good as SOGI-PLL under noise disturbances. Moreover, the FAE shows the fast dynamics again in this case.

In order to further illustrate the performance of the proposed method, a comparison between the proposed FAE and several other methods including CDSC-PLL, APF-PLL and the adaptive observer proposed in [30], under ideal grid and harmonic distortions, respectively. The parameter of CDSC-PLL is set as: $k_p = 92$ and $k_i = 4232$. The parameters of APF-PLL is set as: $k_p = 92$ and $k_i = 4232$. The parameters of the adaptive observer in [30] are set as: $k_p = 444$, $k_i = 4232$, $\tau = 0.05$, $L = [-1.2, -1]$. From TABLE 3, it is obvious that the response time of the PLL-based methods is much longer than the non-PLLs methods because of the existence of the PLL. Moreover, the APF-PLL is unable to track the voltage amplitude accurately under the harmonic variation. Compared to CDSC-PLL, APF-PLL and the adaptive observer proposed in [30], the proposed method has fast detection speed under both ideal and harmonic conditions, and its response time are 4ms and 3.9ms respectively. In addition, the proposed FAE has good robustness against harmonics. In summary, the proposed method shows a satisfactory performance in LVRT operation.

Above all, the experimental results demonstrate the strong performance of the proposed FAE method in terms of fast dynamics. Thus, it can be a promising solution for single-phase systems to enhance the performance under grid faults.

V. CONCLUSION

This paper has proposed a fast amplitude estimation method for single-phase systems to enhance the LVRT operation performance. The estimation is achieved by solving an algebraic model with two unknown parameters, which reflect the amplitude of the grid voltage. Based on the obtained model, a parameter estimator is introduced to identify the two parameters and then the estimation is realized. Compared to the SOGI-PLL method, the proposed solution is a

PLL-independent method, and it has fast dynamics. Experimental tests have verified the performance. The proposed method can be a promising solution for single-phase systems operating under grid faults.

REFERENCES

- [1] J. Rocabert, A. Luna, F. Blaabjerg, and P. Rodriguez, "Control of power converters in AC micro grids," *IEEE Trans. Power Electron.*, vol. 27, no. 11, pp. 4734–4749, Nov. 2012.
- [2] H. Zhou, S. Chen, J. Lai, X. Lu, C. Yu, W. Hu, Q. Deng, and D. Zhou, "Modeling and synchronization stability of low-voltage active distribution networks with large-scale distributed generations," *IEEE Access*, vol. 6, pp. 70989–71002, 2018.
- [3] C. Ma, F. Gao, G. He, and G. Li, "A voltage detection method for the voltage ride-through operation of renewable energy generation systems under grid voltage distortion conditions," *IEEE Trans. Sustain. Energy*, vol. 6, no. 3, pp. 1131–1139, Jul. 2015.
- [4] Y. Yang, F. Blaabjerg, and Z. Zou, "Benchmarking of grid fault modes in single-phase grid-connected photovoltaic systems," *IEEE Trans. Ind. Appl.*, vol. 49, no. 5, pp. 2167–2176, Sep. 2013.
- [5] P.-H. Wu, Y.-T. Chen, and P.-T. Cheng, "The delta-connected cascaded h-bridge converter application in distributed energy resources and fault ride through capability analysis," *IEEE Trans. Ind. Appl.*, vol. 53, no. 5, pp. 4665–4672, Sep. 2017.
- [6] *Technical Rules for Connecting Photovoltaic Power Station to Power Grid*, document Q/GDW 1617-2015, Beijing, China, Dec. 2015.
- [7] H. Geng, C. Liu, X. Zhang, G. Yang, *Low Voltage Crossing of New Energy Grid-Connected Power Generation Systems*. Machinery Industry Press, 2014, pp. 1–4.
- [8] E. Styvaktakis, M. Bollen, and I. Gu, "Automatic classification of power system events using RMS voltage measurements," in *Proc. IEEE Power Eng. Soc. Summer Meeting*, Beijing, China, Jun. 2003, pp. 824–829.
- [9] R. Naidoo and P. Pillay, "A new method of voltage sag and swell detection," *IEEE Trans. Power Del.*, vol. 22, no. 2, pp. 1056–1063, Apr. 2007.
- [10] W. Zou and S. Su, "Voltage flicker detection based on wavelet Fourier transform," in *Proc. Int. Conf. Electr. Control Eng.*, Sep. 2011, pp. 4218–4220.
- [11] K. Liu, W. Cao, J. Zhao, and J. You, "Unified digital phase-locked loop with multiple complex resonators for both single- and three-phase grid synchronization," *IEEE Access*, vol. 5, pp. 24810–24818, 2017.
- [12] X. Cai, C. Wang, and R. Kennel, "A fast and precise grid synchronization method based on fixed-gain filter," *IEEE Trans. Ind. Electron.*, vol. 65, no. 9, pp. 7119–7128, Sep. 2018.
- [13] Y. Kumsuwan and Y. Sillapawicham, "A fast synchronously rotating reference frame-based voltage sag detection under practical grid voltages for voltage sag compensation systems," in *Proc. 6th IET Int. Conf. Power Electron., Mach. Drives (PEMD)*, 2012, pp. 1–5.
- [14] H. Awad, J. Svensson, and M. Bollen, "Tuning software phase-locked loop for series-connected converters," *IEEE Trans. Power Del.*, vol. 20, no. 1, pp. 300–308, Jan. 2005.
- [15] M. Rasheduzzaman and J. W. Kimball, "Modeling and tuning of an improved delayed-signal-cancellation PLL for Microgrid Application," *IEEE Trans. Energy Convers.*, vol. 34, no. 2, pp. 712–721, Jun. 2019.
- [16] D. Somayajula and M. Crow, "An integrated active power filter-ultracapacitor design to provide intermittency smoothing and reactive power support to the distribution grid," in *Proc. IEEE Power Energy Soc. General Meeting*, Jul. 2015, p. 1.
- [17] M. Ciobotaru, R. Teodorescu, and F. Blaabjerg, "A new single-phase PLL structure based on second order generalized integrator," in *Proc. 37th IEEE Power Electron. Spec. Conf.*, Oct. 2006, pp. 1–6.
- [18] R. Teodorescu, M. Liserre, and P. Rodriguez, *Grid Converters for Photovoltaic and Wind Power Systems*. Hoboken, NJ, USA: Wiley, 2011.
- [19] F. Xiao, L. Dong, L. Li, and X. Liao, "A frequency-fixed SOGI-based PLL for single-phase grid-connected converters," *IEEE Trans. Power Electron.*, vol. 32, no. 3, pp. 1713–1719, Mar. 2017.
- [20] S. Golestan, S. Y. Mousazadeh, J. M. Guerrero, and J. C. Vasquez, "A critical examination of frequency-fixed second-order generalized integrator-based phase-locked loops," *IEEE Trans. Power Electron.*, vol. 32, no. 9, pp. 6666–6672, Sep. 2017.
- [21] S. Golestan, J. M. Guerrero, and J. C. Vasquez, "Single-phase PLLs: A review of recent advances," *IEEE Trans. Power Electron.*, vol. 32, no. 12, pp. 9013–9030, Dec. 2017.
- [22] S. Gude and C.-C. Chu, "Single-phase enhanced phase-locked loops based on multiple delayed signal cancellation filters for micro-grid applications," *IEEE Trans. Ind. Appl.*, vol. 55, no. 6, pp. 7122–7133, Nov. 2019.
- [23] L. Wang, Q. Jiang, L. Hong, C. Zhang, and Y. Wei, "A novel phase-locked loop based on frequency detector and initial phase angle detector," *IEEE Trans. Power Electron.*, vol. 28, no. 10, pp. 4538–4549, Oct. 2013.
- [24] Y. F. Wang and Y. W. Li, "Grid synchronization PLL based on cascaded delayed signal cancellation," *IEEE Trans. Power Electron.*, vol. 26, no. 7, pp. 1987–1997, Jul. 2011.
- [25] F. Liccardo, P. Marino, and G. Raimondo, "Robust and fast three-phase PLL tracking system," *IEEE Trans. Ind. Electron.*, vol. 58, no. 1, pp. 221–231, Jan. 2011.
- [26] I. Carugati, S. Maestri, P. G. Donato, D. Carrica, and M. Benedetti, "Variable sampling period filter PLL for distorted three-phase systems," *IEEE Trans. Power Electron.*, vol. 27, no. 1, pp. 321–330, Jan. 2012.
- [27] J. Svensson, M. Bongiorno, and A. Sannino, "Practical implementation of delayed signal cancellation method for phase-sequence separation," *IEEE Trans. Power Del.*, vol. 22, no. 1, pp. 18–26, Jan. 2007.
- [28] S. Gude and C.-C. Chu, "Three-phase PLLs by using frequency adaptive multiple delayed signal cancellation prefilters under adverse grid conditions," *IEEE Trans. Ind. Appl.*, vol. 54, no. 4, pp. 3832–3844, Jul. 2018.
- [29] F. Xiao, L. Dong, L. Li, and X. Liao, "Fast voltage detection method for grid-tied renewable energy generation systems under distorted grid voltage conditions," *IET Power Electron.*, vol. 10, no. 12, pp. 1487–1493, Oct. 2017.
- [30] Z. Dai, W. Lin, and H. Lin, "Estimation of Single-Phase Grid Voltage Parameters With Zero Steady-State Error," *IEEE Trans. Power Electron.*, vol. 31, no. 5, pp. 3867–3879, May 2016.
- [31] G. Tao, *Adaptive Control Design and Analysis*. Hoboken, NJ, USA: Wiley, 2003.
- [32] *Power Quality-Frequency Deviation for Power System*, document GB/T 15945-2008, 2008.
- [33] P. Rodriguez, A. Luna, I. Candela, R. Mujal, R. Teodorescu, and F. Blaabjerg, "Multiresonant frequency-locked loop for grid synchronization of power converters under distorted grid conditions," *IEEE Trans. Ind. Electron.*, vol. 58, no. 1, pp. 127–138, Jan. 2011.
- [34] A. Luna, J. Rocabert, J. I. Candela, J. R. Hermoso, R. Teodorescu, F. Blaabjerg, and P. Rodriguez, "Grid voltage synchronization for distributed generation systems under grid fault conditions," *IEEE Trans. Ind. Appl.*, vol. 51, no. 4, pp. 3414–3425, Jul. 2015.



JUXIANG ZHANG is currently an Associate Professor with the School of Mechanical and Electrical Engineering, Xidian University, Xi'an. Her research interests include power electronics and motion control.



PEIQI ZHAO received the B.Eng. degree from the Henan Institute of Science and Technology, Henan, China, in 2017. She is currently pursuing the M.Eng. degree with Xidian University. Her research interests include power electronics on distributed power systems, adaptive control, and phase-locked loops.



ZHEN ZHANG received the B.S. degree in automation and the M.S. and Ph.D. degrees in electrical engineering from Northwestern Polytechnical University, Xi'an, China, in 2009, 2012, and 2019, respectively.

From 2016 to 2017, he was a Visiting Scholar with the Department of Energy Technology, Aalborg University, Aalborg, Denmark. He is currently an Assistant Professor with the School of Electronic and Control Engineering, Chang'an

University, Xi'an. His research interests include the control of power converters and motor drive.



YONGHENG YANG (Senior Member, IEEE) received the B.Eng. degree in electrical engineering and automation from Northwestern Polytechnical University, Shaanxi, China, in 2009, and the Ph.D. degree in electrical engineering from Aalborg University, Aalborg, Denmark, in 2014.

He was a Postgraduate Student with Southeast University, China, from 2009 to 2011. In 2013, he spent three months as a Visiting Scholar with Texas A&M University, USA. He is currently an

Associate Professor with the Department of Energy Technology, Aalborg University. His current research is on the integration of grid-friendly photovoltaic systems with an emphasis on the power electronics converter design, control, and reliability.

Dr. Yang was the recipient of the 2018 *IET Renewable Power Generation* Premium Award and an Outstanding Reviewer for the IEEE TRANSACTIONS ON POWER ELECTRONICS in 2018. He is the Chair of the IEEE Denmark Section, the General Co-Chair of the IEEE International Future Energy Challenge (IFEC 2020) and the Publicity Co-chair of the IEEE Energy Conversion Congress and Exposition (ECCE 2020). He serves as an Associate Editor for several prestigious journals, including the IEEE JOURNAL OF EMERGING AND SELECTED TOPICS IN POWER ELECTRONICS, the IEEE TRANSACTIONS ON INDUSTRIAL ELECTRONICS, and the IEEE TRANSACTIONS ON POWER ELECTRONICS. He is also a Subject Editor of the *IET Renewable Power Generation* for Solar Photovoltaic Systems, including MPPT.



FREDE BLAABJERG (Fellow, IEEE) received the Ph.D. degree in electrical engineering with Aalborg University, in 1995.

He was with ABB-Scandia, Randers, Denmark, from 1987 to 1988. He became an Assistant Professor in 1992, an Associate Professor in 1996, and a Full Professor of power electronics and drives, in 1998. In 2017, he became a Villum Investigator. He is currently the honoris causa with the University Politehnica Timisoara, Timisoara, Romania,

and Tallinn Technical University, Tallinn, Estonia. He has published more than 600 journal article in the fields of power electronics and its applications. He is the co-author of four monographs and editor of ten books in power electronics and its applications. His current research interests include power electronics and its applications, such as in wind turbines, PV systems, reliability, harmonics, and adjustable speed drives.

Dr. Blaabjerg has received 31 IEEE Prize Paper Awards, the IEEE PELS Distinguished Service Award, in 2009, the EPE-PEMC Council Award, in 2010, the IEEE William E. Newell Power Electronics Award, in 2014, the Villum Kann Rasmussen Research Award, in 2014, and the IEEE Edison Medal, in 2020. He was the Editor-in-Chief of the IEEE TRANSACTIONS ON POWER ELECTRONICS, from 2006 to 2012. He has been a Distinguished Lecturer of the IEEE Power Electronics Society, from 2005 to 2007 and the IEEE Industry Applications Society, from 2010 to 2011 and 2017 to 2018. He serves as the President of IEEE Power Electronics Society for the period of 2019–2020. He is also the Vice-President of the Danish Academy of Technical Sciences. He is also the 2019 Global Energy Prize Laureate. He was nominated in 2014–2019 by Thomson Reuters to be between the most 250 cited researchers in Engineering in the world.



ZHIYONG DAI received the B.S. and M.S. degrees in electrical engineering and the Ph.D. degree in detection technology and automation device from Northwestern Polytechnical University, Xi'an, China, in 2009, 2012, and 2016, respectively. From 2014 to 2016, he was a Visiting Ph.D. Student with the Department of Electrical Engineering and Computer Science, Case Western Reserve University, Cleveland, OH, USA. He is currently an Associate Professor with the School

of Mechanical and Electrical Engineering, Xidian University, Xi'an. His research interests include power electronics and motion control.

• • •