



Reliability of Power Electronic Systems for EV/HEV Applications

Blaabjerg, Frede; Wang, Huai; Vernica, Ionut; Liu, Bochen; Davari, Pooya

Published in:
Proceedings of the IEEE

DOI (link to publication from Publisher):
[10.1109/JPROC.2020.3031041](https://doi.org/10.1109/JPROC.2020.3031041)

Publication date:
2021

Document Version
Accepted author manuscript, peer reviewed version

[Link to publication from Aalborg University](#)

Citation for published version (APA):
Blaabjerg, F., Wang, H., Vernica, I., Liu, B., & Davari, P. (2021). Reliability of Power Electronic Systems for EV/HEV Applications. *Proceedings of the IEEE*, 109(6), 1060-1076. Article 9250437. <https://doi.org/10.1109/JPROC.2020.3031041>

General rights

Copyright and moral rights for the publications made accessible in the public portal are retained by the authors and/or other copyright owners and it is a condition of accessing publications that users recognise and abide by the legal requirements associated with these rights.

- Users may download and print one copy of any publication from the public portal for the purpose of private study or research.
- You may not further distribute the material or use it for any profit-making activity or commercial gain
- You may freely distribute the URL identifying the publication in the public portal -

Take down policy

If you believe that this document breaches copyright please contact us at vbn@aub.aau.dk providing details, and we will remove access to the work immediately and investigate your claim.

Reliability of Power Electronic Systems for EV/HEV Applications

Frede Blaabjerg, *Fellow IEEE*, Huai Wang, *Senior Member IEEE*, Ionut Vernica, *Member IEEE*, Bochen Liu, *Student Member IEEE*, and Pooya Davari, *Senior Member IEEE*.

Abstract—The electrification of the transportation sector is moving on at a fast pace. All car manufacturers have strong programs to electrify their car fleet to fulfill the demands of society and customers by offering carbon-neutral technologies to bring goods and persons from one location to another. Power electronics technology is in this evolution essential and also in a rapid development technology-wise. Some of the introduced technologies are quite mature and the systems designed must have a high reliability as they can be quite complicated from an electrical perspective. Therefore, this paper focuses on the reliability of the used power electronic systems applied in EVs and HEVs. It introduces the reliability requirements and challenges given for the power electronics applied in EV/HEV applications. Then the advances in power electronic components to address the reliability challenges are introduced as they individually contribute to the overall system reliability. Reliability-oriented design methodology is also discussed, including two examples: an EV on-board charger and the drive train inverter. Finally, an outlook in terms of research opportunities in power electronics reliability related to EV/HEVs is provided. It can be concluded that many topics are already well handled in terms of reliability, but issues related to complete new technology introduction are important to keep the focus on.

Index Terms—Reliability; power converter; EV; HEV; power electronics; thermal management; charger; drive train

I. INTRODUCTION

THE electrification of modern society is going with a very rapid pace to make the society more efficient, sustainable and to reduce carbon footprint – the electrical generation need to be renewable based [1], the electrical transmission and distribution systems are expanded and all aspects of consumption are demanded to be more efficient – mostly enabled by the power electronics technology ability to control the electrical power efficiently. One of the main areas that can dramatically reduce carbon emissions is the electrification of the transportation sector – which is now in development and it is moving with a very strong pace and accelerated penetration. The electrification will not only reduce the carbon emission – it will also improve the air-quality in cities and reduce the noise level significantly. Countries are by legislation moving in that direction – Norway has announced that by 2025 all new cars should be carbon emission-free – Denmark has the same goal by 2030, thus, such decisions will pave the way for a very fast implementation [2] if the necessary electrical infrastructure will follow. Germany has analyzed about how to become decarbonized by 2050 [3], here indicating that many technical solutions are possible and there are also many challenges. However, a recent study by Bloomberg [4] said that by 2040 more than 50% of all sold cars will be electrified,

meaning a market of +40 million electric cars. Car technology can be different – it can be fully electric vehicles (EV's), it can be hybrid electric vehicles (HEV's), where the battery size typically is the defining difference in order to obtain the wanted range of the car, or it can be based on systems where the generated electricity is converted to gas or fuel [3]. Common for all electrical solutions is that power electronics technology is applied for the power processing in many aspects – it is used for the drive-train, for the battery management system, for charging the battery and delivering power to all auxiliary units in a vehicle. Common demand for the applied technology is that it should be as reliable as needed to the lowest cost – and for some of the parts, failure is not an option due to safety. As the EV/HEV is not fully mature yet – e.g., the promising wide bandgap power devices are not fully developed; also, more and more specialized integration (thermal management) of the power electronics is seen in the solutions with uncertainties; further on condition monitoring enters into the vehicle with advantages and potential risks in terms of higher complexity. Therefore, modern reliability engineering methods are steadily being developed and applied to the transportation sector.

Reliability is an important performance metric, which needs to be carefully considered during design, manufacturing, testing and field operation of EVs/HEVs. Reliability is defined as the probability that a product will perform its designated function without failure, under stated conditions, for a given period of time [5]. However, due to its large number of interdependent components and sub-assemblies, the power electronics system of the EV/HEV is susceptible to a wide range of failure modes and failure mechanisms. Also, having in mind that vehicles are mass-produced and there is an expectation of high reliability and low operational/maintenance cost. To achieve this, it demands life-cycle-cost reduction and performance boost of power electronic converters through innovative design and testing methods, an in-depth understanding of the component and system failure mechanisms, and predictive maintenance programs, when the car fleet is operating. With such information, it is also possible to online learn about the design and how to do predictive maintenance if needed. Reliability involves many aspects in terms of handling and optimizing it. Aspects like the application lifetimes (e.g., private or autonomous car), longer time between its maintenance, very few early failures (even zero) and the ability to survive fault events in the power electronic systems.

From the system-level perspective, the failure modes that occur in the EV/HEV power electronic system can be divided

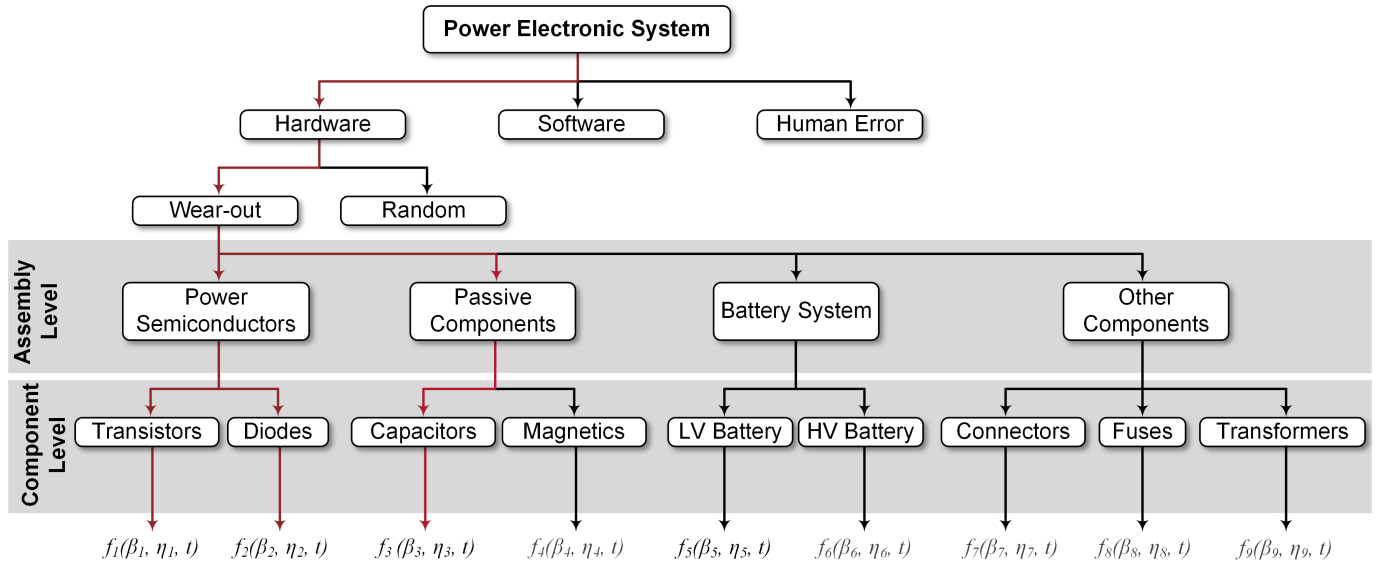

Fig. 1. Typical failure modes of the EV/HEV power electronic system.

into software failure, failures caused by human error, and hardware failures. The latter can be further classified into wear-out failures and random (or catastrophic) failures. Due to the lack of accurate modeling or estimation approaches for failures induced by random events or human error, failure mode and effect analysis (FMEA) and qualitative accelerated test methods can be used to investigate the target components/sub-assemblies under these types of failures. Software failures are not included in the scope of the paper, but several software reliability modeling and assessment methods are presented in [6]. On the other hand, for hardware wear-out failures, a more realistic reliability assessment procedure can be carried out based on the Design for Reliability (DfR) [7] and Physics-of-Failure (PoF) [8], complementing conventional reliability methods. The main power electronic assemblies and components affected by the time-dependent wear-out failure function $f_x(\beta_x, \eta_x, t)$ are showcased in Fig. 1. In this paper, the main focus is placed on the wear-out failure of the power semiconductor devices and capacitors, as they are two of the most prone-to-failure components of the power electronic system [9].

Three main aspects exist for power electronics reliability engineering, which are related to a fundamental knowledge base (physics of failure), a design stage (design for reliability and robustness validation), and an operational phase (intelligent control and condition monitoring) [10]–[12]. Therefore, to master power electronics reliability engineering, many aspects are important. Power cycling testing of power modules is essential to understand the wear out of the power components, when they are in operation, and predict when failures might occur [13] e.g., through degradation. Variations in packaging technologies, test strategies for the power cycling, failure mechanisms, and failure analysis methods are all aspects to consider. Methods to estimate the stress conditions (i.e., junction temperature) and health conditions of power modules are of high interest [14]–[16]. Using wide bandgap devices and new packaging technologies [17, 18], which are being

adapted to the transportation sector and their reliability requirements, are also important. Chip-level and packaging-level failure mechanisms, testing, and condition monitoring health indicators of SiC/GaN devices are also attractive topics [19]. Besides active components, the capacitor reliability is also essential to understand and take into consideration when doing reliability analysis for the complete system [20]. Batteries, their state-of-charge and remaining useful life are important to know – though in this paper, the battery technology itself incl. power electronics for balancing is not discussed. Already now reliability standardization is moving forward in the EV/HEV industry. In [21], the robustness of the power electronics, incl. validation, has been published for the automotive applications, and in [22] a standard was defined on how to make reliability prediction based on field return data. More recommendations/standards are under development. This paper focuses on the reliability aspects of the power electronic systems in EVs and HEVs. First, it will start with the reliability requirements and challenges for the power electronics applied in EV/HEV applications in Section II. Next, the advances in power electronic components to address the reliability challenges will be discussed as they individually contribute to the overall system reliability, which is discussed in Section III. To improve the system reliability – reliability-oriented design can also be applied and it is exemplified in Section IV. In Section V, a specific outlook in power electronics reliability research opportunities related to EV/HEVs will be provided. Section VI gives the main conclusions of the paper.

II. RELIABILITY REQUIREMENTS AND CHALLENGES OF POWER ELECTRONICS FOR EV/HEV APPLICATION

Automotive application with a typical expected operating life of more than 10 years, ambient temperature operating range of $-55\text{ }^{\circ}\text{C}$ to $150\text{ }^{\circ}\text{C}$ and with zero acceptable failure rate is one of the most challenging applications from the reliability aspect. These requirements are in place for both combustion engine based and electric vehicles. Furthermore, high safety

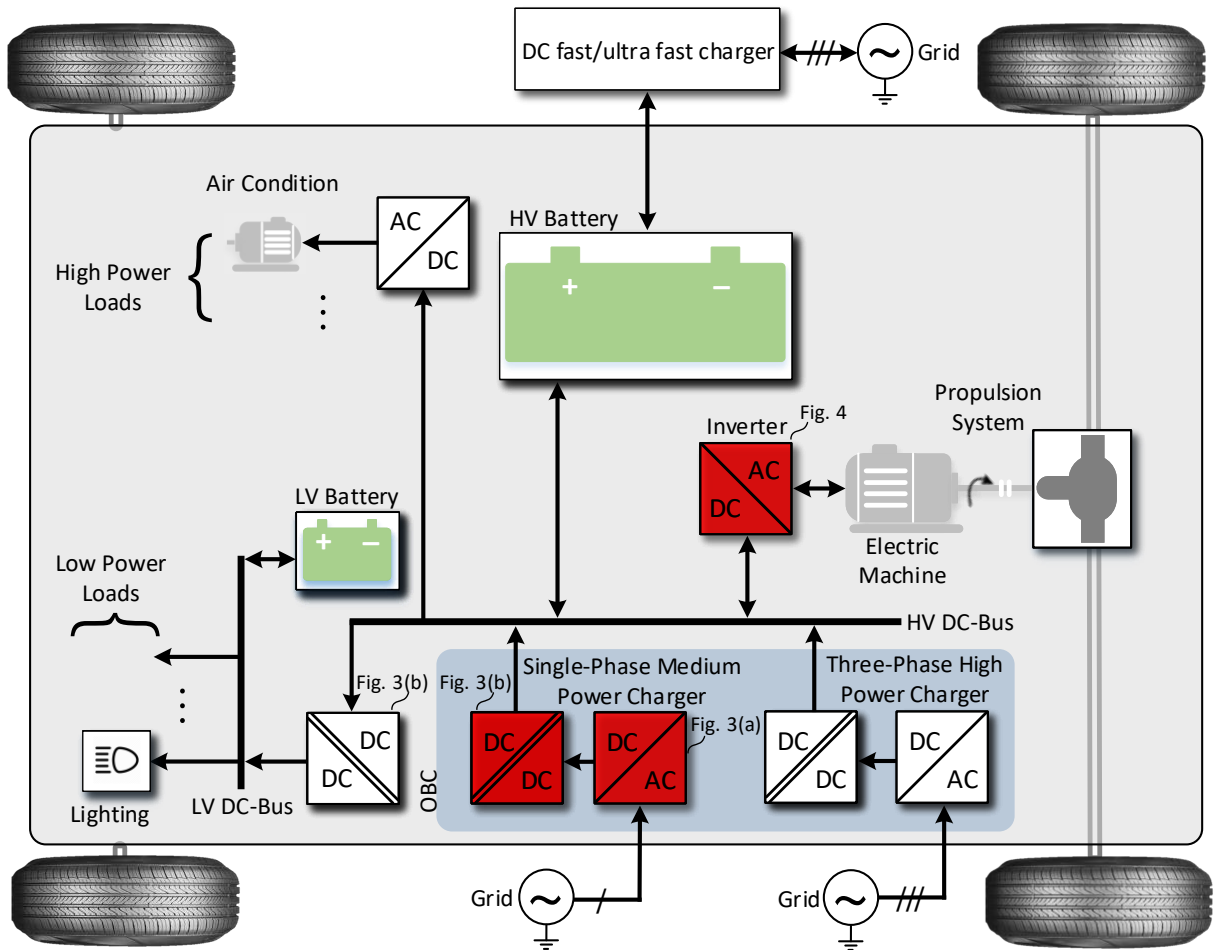

Fig. 2. Overview of the electrical power system in EV/HEV.

level is another requirement for this type of applications. It is expected that the incorporated systems fail gracefully. This implies considering system redundancy or the ability of an alternative system (which was not originally designed for that particular task) to take over the operation of the failed system. For EV/HEV, the power electronics technology is the main key enabler and main driver for advances in automotive electronics technology. EV/HEV electrification involves different power levels and voltage levels (e.g., 12 and 450 V), which requires the incorporation of power electronics technology at various levels. Thereby, to fulfill automotive expected operating life, acceptable failure rate and safety level, high reliability of power electronic components is an essential requirement for EV/HEV applications.

A. Power Conversion Architecture in EV/HEV

To understand the involvement of power electronics at various levels in an electric vehicle power system, Fig. 2 shows a block diagram of a typical electrical power system architecture in EV/HEV, including the major power electronic systems that can be found in an electric-based vehicle [23, 24]. Here the high voltage (HV) DC-Bus is typically in the range of 250 Vdc to 450 Vdc depending on the utilized battery voltage and the low voltage (LV) DC-bus is rated at 12/48Vdc.

Notably, different possible configurations for the power train in EV/HEV can be found in the automotive market [25]–[28].

The on-board charger (OBC) is an essential part of the EV and plug-in HEV. OBC has two main roles; firstly, charging the battery through the main power grid and secondly power factor correction (PFC) to provide high power factor (≈ 0.99) and low harmonic distortion following the standard grid codes. According to SAE J1772 [29] three power levels are defined for OBCs. The power level depends on the available voltage and current capacity from the main grid and it can be as low as 1.9 kW up to 43 kW [30]. Single-phase OBC is the most adopted charger in the current vehicles and it can be rated as high as 19.2 kW. However, it is more suitable to adopt three-phase OBC for power levels above 7.4 kW (or up to 7.7 kW single-phase with 240V at 32 A) due to components count and efficiency. This is why most EV/HEV worldwide are currently utilizing OBC between 6.6 kW and 7.4 kW. Fig. 3(a) shows the most popular single-phase OBC topology also known as interleaved boost PFC. Although interleaved boost PFC has advantages from efficiency and power density over single-switch boost PFC, but it requires higher components count, which may lead to lower reliability. However, since each boosting stage in the interleaved PFC is designed to

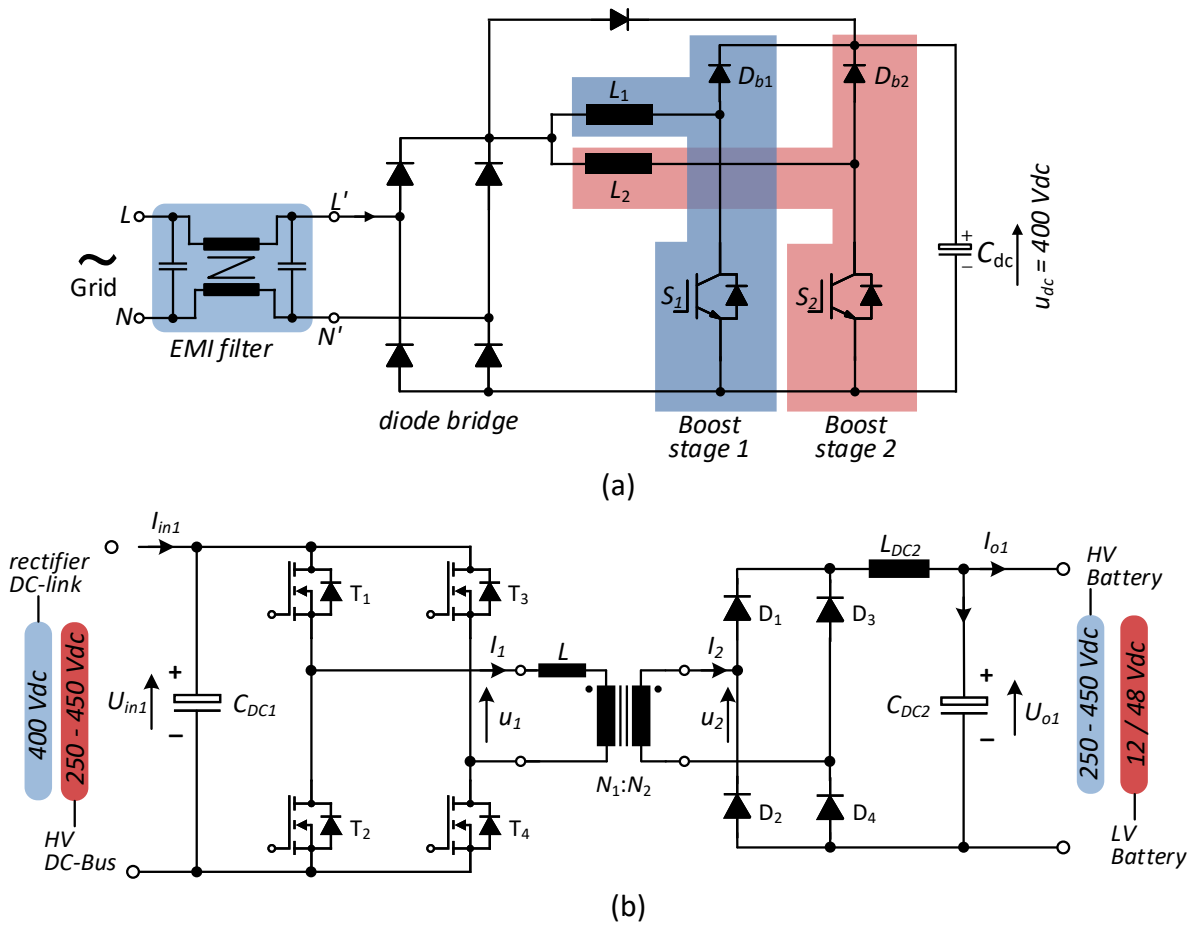

Fig. 3. Block diagram of on-board charger and DC-DC converters: (a) single-phase AC/DC with interleaved boost PFC topology, (b) isolated DC-DC converter with unidirectional phase shift full bridge (PSFB) configuration.

handle half of the rated power, it can provide redundancy to the system if one boosting stage fails. Therefore, the OBC can continue charging the battery up to half of its rated power. Currently, research and development are undergoing on more advanced topologies such as totem-pole PFC with wide-band gap (WBG) devices to further improve the efficiency and the power density of OBC. The long-term trend is moving towards bidirectional charging, where EV/HEV can support the power grid by feeding the battery power back to grid [31].

One of the main challenges with OBC is the charging time. With continuous increase of battery capacity (i.e., extended vehicle driving range), the demand for higher power chargers increases. Although, fast and ultrafast DC charging stations (i.e., > 350 kW) [1] can minimize the charging time (e.g., 10-15 mins), since they are not widely available yet, car manufacturers are adopting high-power OBC through a three-phase supply (see Fig. 2). In most commercial vehicles due to power density and size limitations, the three-phase OBC power level is from 11 kW up to 20 kW except for Renault Zoe, which is rated at 43 kW using the integrated motor drive and OBC configuration [30]. Notably, depending on the topology the HV DC-bus voltage will be different [32, 33].

Fig. 3(b) shows a typical isolated DC-DC converter topologies employed in electric-based vehicles. The DC-DC con-

verter is employed at two stages. Firstly, to charge the battery from the active front-end rectifier. At this stage the DC-DC converter should provide the HV DC bus (e.g., typically at 250 V – 450 Vdc). Another DC-DC converter based on the same topology is adopted to form the LV DC bus which can be at 12 Vdc or 48 Vdc depending on the vehicle low voltage load types (see Fig. 2). Due to the safety requirements, the DC-DC converter should isolate the power grid from HV DC-Bus and HV DC-Bus from LV DC-Bus [34, 35].

As it is depicted in Fig. 3(b), the converter comprises of primary and secondary sides. The isolation transformer can be formed employing a resonant network based on a series resonant converter (SRC), also known as an LLC configuration. As shown in Fig. 3(b), an alternative method is to adapt the transformer leakage inductance (additional inductance may be required), which is known as phase shift full bridge (PSFB) converter.

While the primary side is based on an H-bridge configuration, the most in use configuration for the secondary is a diode bridge. Although it can only provide a unidirectional power flow, utilizing a diode bridge can simplify converter from gate driver requirement, reduce cost and improve reliability. However, it may adversely affect the converter performance from an efficiency point of view, causing high conduction

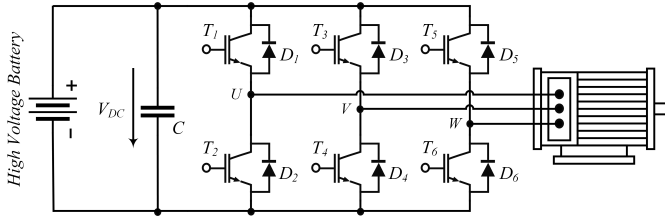

Fig. 4. Block diagram of standard voltage source inverter (VSI) topology used in the propulsion system.

losses from diodes and having low flexibility on the applied modulation technique.

The PSFB converter can provide a promising performance of operating with fixed switching frequency, soft-switching, low filter requirement and wide power and voltage ranges [34, 36]. The resonant-based converters can achieve a high performance for a specific application needs. However, maintaining their performance over a wide range of power levels and voltage gain ratios and their variable switching frequency nature may also reduce the converter efficiency. Furthermore, tuning the resonant network for high frequency operation considering the layout, switches and transformer parasitic is challenging. Therefore, PSFB converter shows promising performance over resonant-based in adapting to different application needs, while maintaining a desirable converter performance. This has become a new trend to adapt PSFB converters based on WBG devices for EV/HEV applications [31, 34, 35, 37].

One of the main components in an electric-based vehicle is the electric machine (EM) and its inverter (Fig. 4). The EMs utilized in today's EV/HEV are commonly AC induction machine or AC permanent magnet (PM) type [46, 47]. The majority of the main inverters for HEV are in the range of 30 – 60 kW, while in EVs the rated power is beyond 100 kW. In the near future, the power rating will reach 500 kW [47]. Intensive research and development are currently going on enhancing PM EMs and adopting different types of EMs in order to further improve the performance of future electric-based vehicles [48]. Compared to the OBC, the main inverter will be imposed on more power cycling, which means that the adopted power electronic components should endure a higher number of active and passive thermal cycles. Due to their higher power capabilities, in some EV/HEV applications, the main inverter is re-used for OBC, which are referred to as on-board integrated chargers or propulsion system integrated OBCs [30, 49]. For instance, Renault Zoe uses an integrated Chameleon charger rated up to 43 kW [23, 30]. Further investigations are required from a reliability perspective since the components are utilized for both OBC and main inverter operation exposing them to higher thermal cycling stress.

Different types of commercial power switching devices are designed for all mentioned power converters in automotive applications. Currently, most of the EV/HEV are employing insulated-gate bipolar transistors (IGBTs) for high power, while using silicon metal-oxide-semiconductor field-effect transistors (Si MOSFETs) for DC-DC converters, which can achieve zero voltage switching (ZVS) for further loss reduction. The future trend is to replace the silicon switches with

silicon carbide (SiC) and gallium nitride (GaN) devices (i.e., WBG devices), which can further reduce the power loss and system size through their high switching operation capability. For instance, Tesla has moved to utilized SiC devices for both OBC and the main inverter [23].

B. Reliability Aspect Challenges

Fig. 5 shows the automotive lifetime requirements and power electronics research and development for electric-based vehicles [38]–[42]. As shown in the figure, with the everlasting needs of efficiency and power density improvement, power electronic components face more and more stringent operating conditions in EV/HEV applications [38, 42]. High power, high voltage and higher converter switching frequency operations are required to fulfill these needs, which, combined with vehicle stringent operating conditions, create a harsh environment.

Table I shows the different source of stress for power electronic components [43]. Furthermore, this table has exemplified typical environmental and stress test conditions for EV/HEV applications [20, 44, 45]. As can be seen from the table, temperature stress is a major stressor that destroys power electronic components. This stress factor can be counted as a maximum steady-state temperature and temperature cycling.

To account for the first one, it is vital to make a good cooling system so that component's temperature never exceeds their specified maximum rated temperature. In automotive applications, to prevent an oversized cooling system, it is important to make a good thermal design by identifying the worst-case operating case from the vehicle mission profiles due to size and volume limitations. However, this will not guarantee the expected lifetime of power devices, as the high probability of power device failures is primarily due to temperature cycling [43]. The main cause of temperature cycles are active power cycling and passive temperature cycling [50, 51]. Although both results in temperature swings adversely affecting power component lifetime, they are different.

The active power cycling leads to temperature swings due to the power dissipated in the power electronic components. This generates high temperature gradients and inhomogeneous temperature distribution among power electronic devices and components. To minimize the thermal swings due to active power cycling, active thermal control methods can be applied [52]–[54]. Active thermal controls are based on two principles. Firstly, minimizing the power dissipation through switching and conduction loss reduction. Secondly, by re-routing the flowing path of the current among the power devices [55, 56], both cases can be achieved through suitable selection of the modulation strategy and reactive power control. As it is exemplified in Table I in EV/HEV, the active thermal cycles can go beyond 100 °C, which might significantly reduce the life of the power devices.

In EV/HEV, passive temperature cycling represents a challenging condition considering the reliability requirements in automobiles comparing to other applications. Passive temperature cycles occur due to environmental temperature changes such as variation in the ambient temperature or cooling liquid temperature. This becomes further challenging when the

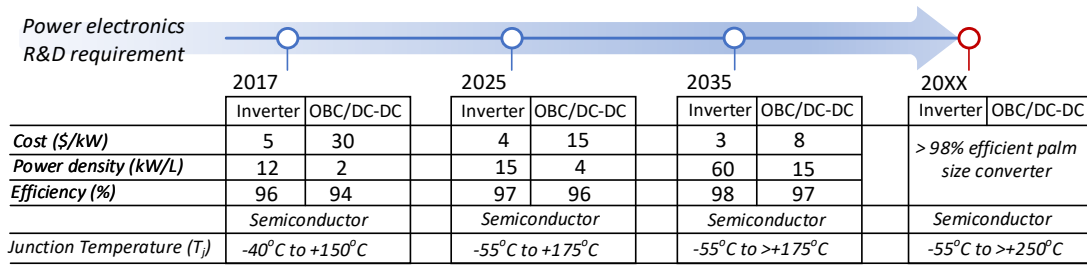

(a)

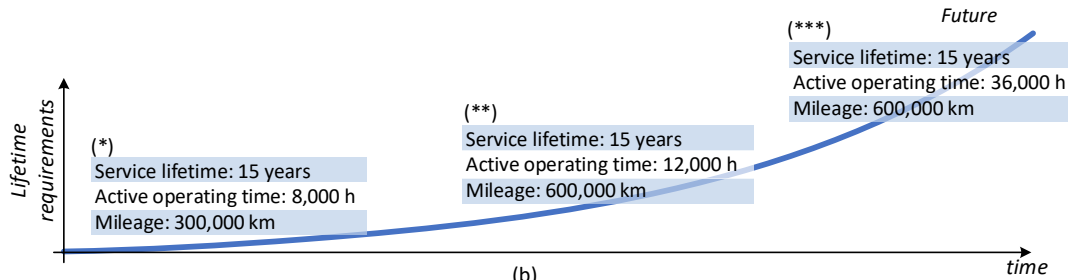

(b)

Fig. 5. R&D and lifetime requirements in EV/HEV: (a) power electronics R&D development roadmap for electric-based vehicles based on the reports in [38] and [39], (b) automotive lifetime requirements based on [39], *[40], **[38], ***[41].

TABLE I
SOURCE OF STRESS FOR POWER ELECTRONIC COMPONENTS IN ELECTRIC-BASED VEHICLES [20, 38]–[45]

Source of Stress Conditions	Temperature steady State & Cyclical 55 %	Vibration/Shock 20 %	Humidity/Moisture 19 %	Contaminants & Dust 6 %
Typical	ambient temperature -55 °C to 150 °C	(Chassis): 2.2 to 4.4 G (Engine): 20 to 40 G	(Maximum) 38 °C / 95 % RH 27 °C / 91 % RH	
Stress Test	passive thermal cycle (SM,R & F-Cap): -55 °C to 150 °C (MG/Al-Cap): -40 °C to 150 °C active thermal cycle (SM): $\Delta T_j \geq 100$ °C	(SM): 100 Hz to 2 kHz @ 50 G (Others): 20 min, 12 cycles @ 5G	85 °C / 85 % RH	Exposing to salt spray and chemicals

SM: Semiconductor, R: Resistor, F-Cap: Film Capacitor, MG: Magnetics, Al-Cap: Aluminum Capacitor

hot engine liquid cooling system is utilized for the power electronics, with typical high temperature of cooling liquid in 90 °C to 125 °C [57]. Due to the high dwell time during passive temperature cycles, there are no temperature gradients. Besides, the temperature ranges may go as low as -55 °C up to 150 °C. Passive thermal cycles may cause higher stress on the power devices [51]. Thereby, electric-based vehicle power electronic components need to be designed and tested considering the possible passive thermal cycles (as exemplified in Table I).

Table I also shows that humidity and vibration are another two critical types of stressors, which are of high relevance to automotive applications. Humidity and condensation cause problems in electronic circuits due to its electrically conductive and corrosive nature [58]. Understanding the humidity-related failure mechanisms and component- and system-level

mitigation methods are needed to reduce corrosion-related failure [59]. With the higher mechatronics integration level of power electronics, increased vibration and shock stresses are expected in EV/HEV applications. For example, multilayer ceramic capacitor is one type of vibration and shock sensitive electronic components [60].

Considering the different stress factors and field return data in power electronics, the reliability issues of power semiconductors and capacitors stand out [9]. In automotive applications, the interconnects among components and within the packaging are also reliability-critical due to vibration and thermal-mechanical stresses. Combine with the ability to withstand transient high voltage and current (e.g., during sudden acceleration and braking), power components must be selected to withstand EV/HEV operating conditions and perform smoothly in those conditions.

TABLE II
REGULATORY REQUIREMENTS FOR AUTOMOTIVE GRADE POWER ELECTRONIC COMPONENT MANUFACTURERS

<i>Standard</i>	<i>Description</i>
IATF-16949	Automotive Quality Management System Standard
AEC-Q100	Stress Test Qualification for Integrated Circuits
AEC-Q101	Stress Test Qualification for Discrete Semiconductors
AEC-Q102	Stress Test Qualification for Optoelectronic Semiconductors
AEC-Q104	Stress Test Qualification for Multichip Modules
AEC-Q200	Stress Test Qualification for Passive Components
IPC-6011	Generic Qualification and Performance Specification for PCBs
IPC-6012DA	Qualification and Performance Specification for Rigid PCBs
IPC-6013D	Qualification and Performance Specification for Flexible and Rigid-Flexible PCBs

This means components need to deal with inhospitable conditions with increased reliability helping to maximize a vehicle’s lifetime, and consequently, they should be subjected to much harsher test conditions compared to components utilized in common power electronic applications.

C. Automotive-Grade Power Electronic Components

To ensure essential requirements for automotive-grade power electronic components, specific certification requirements are put in place by International Automotive Task Force (IATF) and Automotive Electronics Council (AEC). While IATF ensures an optimal level of quality for automotive-grade components, AEC determines the stress test qualification of components. Furthermore, Industry association for Printed Circuit board (IPC) provides the specification for design and development process of Printed Circuit Boards (PCBs). Table II summarizes the common required certification for automotive-grade power electronic components.

Notably, depending on the design specification, power semiconductor modules might be a better choice over discrete semiconductors due to lower processing requirements, tooling and engineering costs. However, as shown in Table II, there is a lack of qualification standards for power semiconductor modules. In 2019, the European Center for Power Electronics (ECPE) has released AQG 324, which is a guideline on “Qualification of Power Modules for use in Power Electronics Converter Units in Automotive Application” [61]. Currently, most manufacturers have adopted this qualification guideline for their automotive-grade power module products.

III. ADVANCES IN POWER ELECTRONIC COMPONENTS TO ADDRESS RELIABILITY CHALLENGES

Section III and Section IV present the power electronic component-level technology advancements and system-level design methodologies to address the challenges discussed in Section II. It represents the joint efforts from power electronic component suppliers and system designers, respectively. To limit its scope, this paper focuses on the advances in power modules and capacitors only in Section III as below, and mission-profile based design for reliability method considering thermal-related wear out issues in Section IV.

A. Power Modules

The advancements in wide bandgap semiconductor materials and power module packaging technologies are two of the enablers to realize the roadmap shown in Fig. 5. It is reported that SiC MOSFETs with conventional packaging have lower power cycling capability than Si IGBTs [62]. Various advanced packaging concepts are proposed as surveyed in [18] to overcome the challenges in reliability, high-temperature operation, and low parasitic inductance. Fig. 6 shows the respective advances in packaging elements for interconnection, substrate, and die attach of power modules as presented in [18]. The maximum temperature of the next-generation automotive module is expected to reach 175 °C. This can substantially enhance the reliability. Since the temperature is closely dependent on the thermal resistance, a low overall thermal resistance is expected by using high thermal conductivity materials from the chip to the base plate, such as AlN and Si3N4 ceramic. For the manufacturers, enhancing the interconnections between chips is a potential choice to delay the bond wire liftoff [63]. Relevant techniques include heavy copper wire bonding, sintered connections, and buffer layers between different materials [64, 65]. Moreover, the bond wire-related failures can be avoided by removing the bond wires from the power module and replacing them with direct lead bonds [66, 67].

By leveraging the emerging concepts in packaging elements, different package structures are proposed, which help overcome the challenges in automotive applications. Fig. 6 shows the advances in packaging structures, as presented in [18]. Overmold structures enhance modularity and reduce the size and weight of power modules. The packaging structure optimization efforts could be developing the cooling structure from the conventional indirect water cooling to single-sided or double-sided direct water cooling [68]. Besides, the pin fins of the direct liquid cooling can also be optimized in terms of shape and layout. Examples can be found in [69]–[72]. The Hitachi double-side cooling power modules from Audi e-tron’s inverters are introduced in [73]. New technology itself may imply uncertainties in reliability aspect performance. Therefore, adequate testing methods and standards are important tools to accelerate the adoption of the latest advancements in power

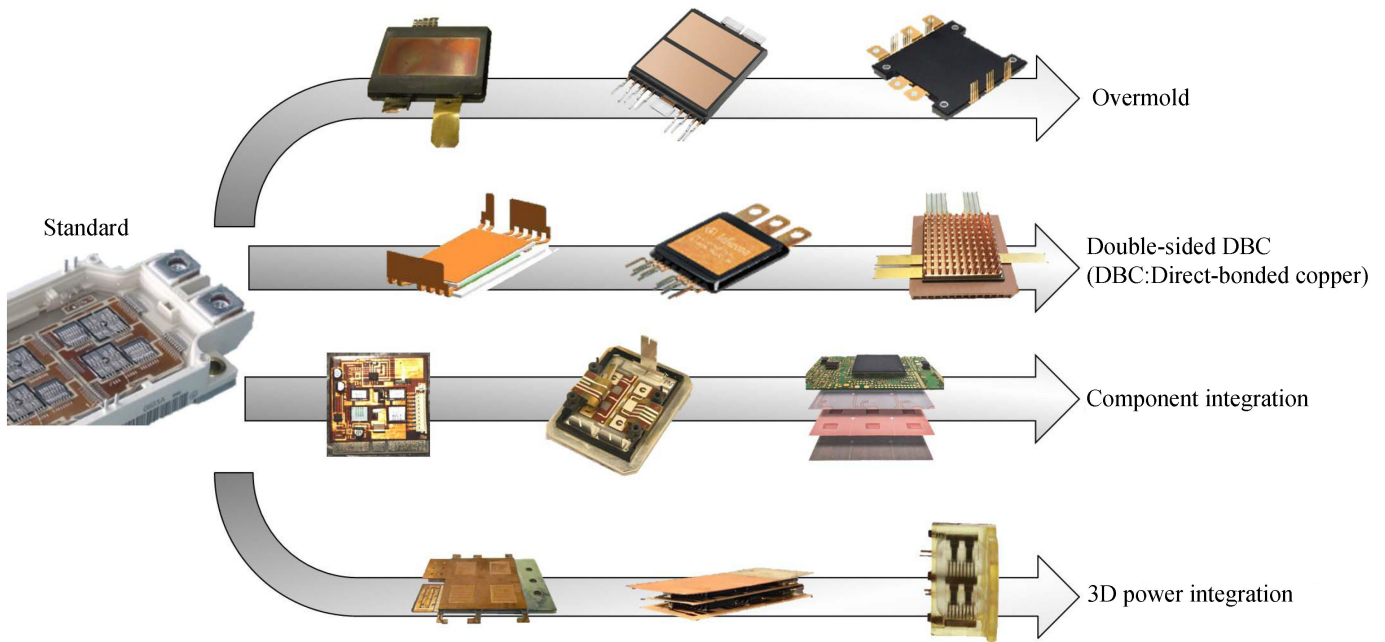

Fig. 6. Advances in packaging elements for power modules [18].

modules.

B. Capacitors

In EV and HEV applications, film capacitors, electrolytic capacitors, and ceramic capacitors are widely used for vehicle motor drives, on-board chargers, and other electronic systems. Three aspects of advancements are going on for different types of capacitors. Firstly, at the material level, research activities on dielectric films to increase energy density and upper temperature limits of existing film capacitors are discussed in [74]. Anti-ferroelectric ceramics are applied in the CeraLink capacitors from TDK-EPCOS, which overcome the capacitance stability issues under voltage bias and maintain performance at high operation temperature up to 150 °C. Secondly, at the packaging level, high vibration and mechanical stress create demands for anti-vibration methods. Thirdly, at the application level, design strategies for low-inductive DC-link capacitor bank design are developed for the trend of using an increasing switching frequency [75].

C. Cooling Assemblies and Concepts

The demands for increasing power density and reducing cost bring a great challenge for the on-board cooling system. Besides, the ambient temperature under the hood could be as high as 100 °C with high humidity [77]. Furthermore, the frequent acceleration/deceleration of the vehicle could lead to large power cycling and surging, which will further challenge the cooling system. Another challenge is that the traction inverter is expected to share one cooling system with the engine for the sake of cost and complexity. To cope with the challenges above, currently, there are three research directions to protect the power electronic components from being overheated, i.e., improving the power package design as discussed in Section III Part A, developing advanced thermal

interface material [78] and utilizing more powerful cooling techniques [79].

Regarding the cooling techniques, the conventional natural and forced convection of air cooling is no longer practical. In the earlier versions of electric cars, such as the Nissan Leaf, forced air cooling is used for the on-board charger at the charging level 1 (1.44 kW). With motor driving and boosted charging power, liquid cooling becomes a popular choice in the automotive industry. The extensively utilized forced convection of liquid cooling and the simple two-phase boiling technique is gradually difficult to satisfy the heat transfer requirement with the adoption of WBG devices and higher power density requirements. Therefore, advanced cooling technologies, such as spray cooling and jet impingement, are developed to meet the demands of the automotive industry [79].

IV. RELIABILITY-ORIENTED DESIGN OF POWER ELECTRONIC SYSTEMS

A. Concepts of Mission-profile-based Design of Power Electronics

In past decades, a paradigm shift from the conventional statistics-based reliability evaluation procedures towards a physics-of-failure-based lifetime estimation of power electronics has been gaining more and more attraction [11]. The Physics-of-Failure (PoF) concept implies that the root failure causes and failure mechanisms of the electrical/electronic components are well understood, before being modeled under realistic operating and environmental conditions [8]. However, most of the available PoF models focus on microelectronic components and cannot be scaled and utilized for power electronics. Thus, empirical lifetime models based on PoF understandings are commonly applied for modeling the wear-out failure of power electronic components [82]. In addition,

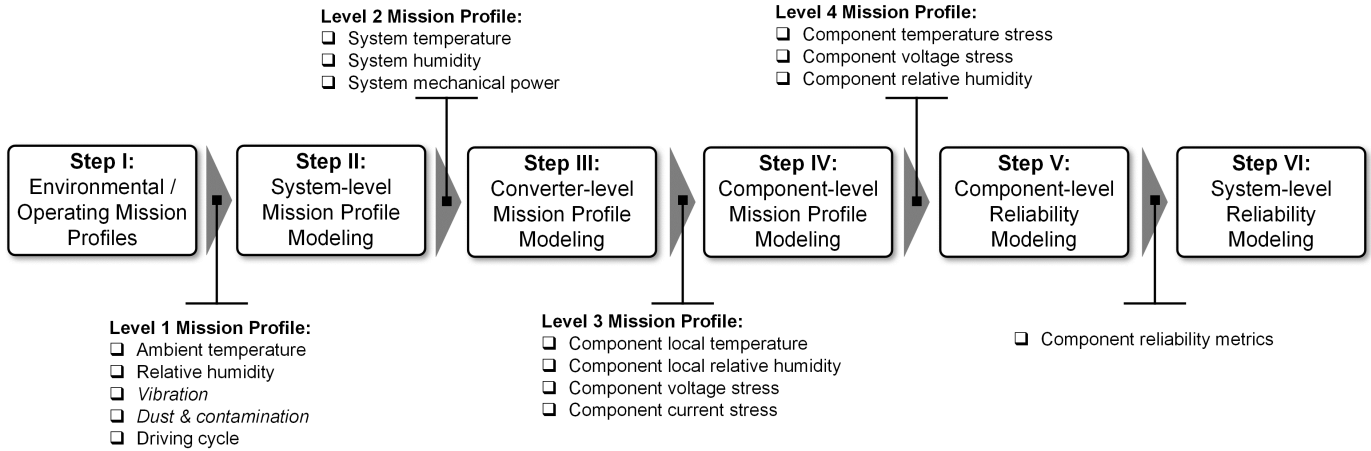

Fig. 7. General mission-profile-based reliability assessment procedure for power electronic systems [76].

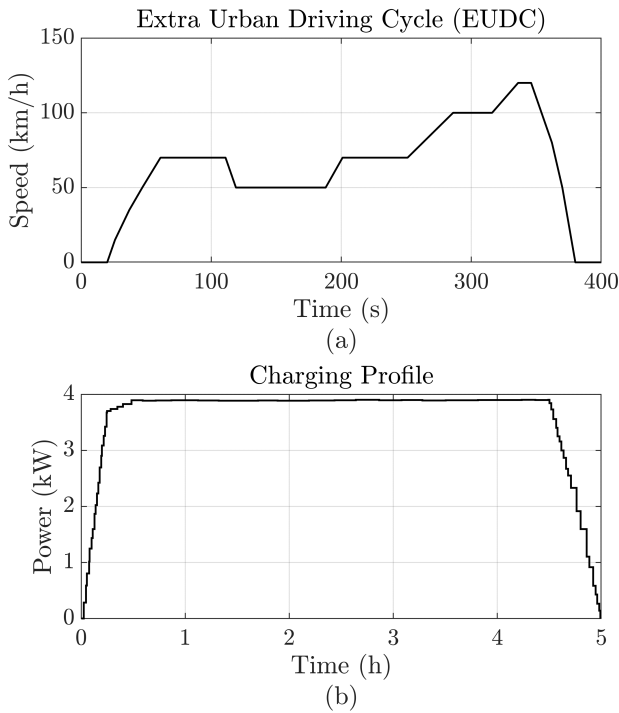

Fig. 8. Typical operational mission profiles for the two sub-assemblies (a) Electric vehicle driving cycle [80], and (b) Scaled-down power demand for an EV on-board charger (based on [81]).

the Design for Reliability (DfR) method, which is defined as the process carried out during early product development stages to ensure certain reliability and quality targets, is used alongside the PoF concept [7, 83].

As a result, many mission-profile-based reliability assessment procedures, which incorporate the DfR method and PoF understandings of power electronics, have been proposed and successfully applied for various applications (e.g., wind power converters [84], grid-connected PV inverter [85], variable frequency drives [86], or more electric aircraft [87]). For EV/HEV applications, the main focus has been placed on the reliability evaluation methodology of the power module used

within the electrical drive train inverter [88]–[90]. Moreover, a thorough six-step mission-profile-based lifetime estimation procedure, which assesses the reliability of power electronics, both at component-level and system-level, has been proposed in [76]. A general overview of the reliability assessment process is given in Fig. 7.

The above-mentioned methodology requires extensive knowledge of the mechanical, electro-thermal and lifetime parameters of the vehicle drive train and of the individual power electronic components. The vehicle driving cycle and the ambient temperature form a representative collection of operating and environmental conditions, and are considered as the input mission profiles for the reliability assessment procedure. It should be noted that stressors such as vibration or dust and contamination, are currently not considered during the reliability modeling procedure, due to the lack of empirical lifetime models. According to the mechanical parameters of the vehicle, in Step II, the input mission profiles are converted into the mechanical power required by the Electrical Machine (EM) used in the drive train. By employing the electro-mechanical models of the vehicle drive train, the mechanical power is used to determine the voltage and current loadings of the power electronic components in Step III. The resulting electrical stressors (e.g., current and voltage) represent the inputs to Step IV, in which electro-thermal models are utilized for calculating the thermal loading of the components of interest. In Step V, the thermal and electrical stressors are used together with empirical lifetime models in order to estimate some of the vital reliability metrics (e.g., lifetime distribution, unreliability curve, etc.) of the power electronic components. Finally, within Step VI, using Reliability Block Diagram (RBD) analysis, the individual component reliability information can be merged, and the system-level reliability estimation can be determined. A more detailed description of the mission-profile-based reliability assessment procedure is given in [76].

B. Reliability Analysis of an Electric Vehicle Case Study

To demonstrate the applicability of the proposed reliability evaluation method, two sub-assemblies (e.g., main traction

TABLE III
PARAMETERS OF A 75 kW DRIVE TRAIN PMSM USED FOR RELIABILITY STUDY

Parameter	Value
Peak motor power	75 (kW)
Stator resistance	1 (mΩ)
d-axis Inductance	7.2 (μH)
q-axis Inductance	7.5 (μH)
Magnetic flux	0.0095 (Vs)
Number of pole pairs	10 (-)
Rotor inertia	0.023 (kg · m ²)

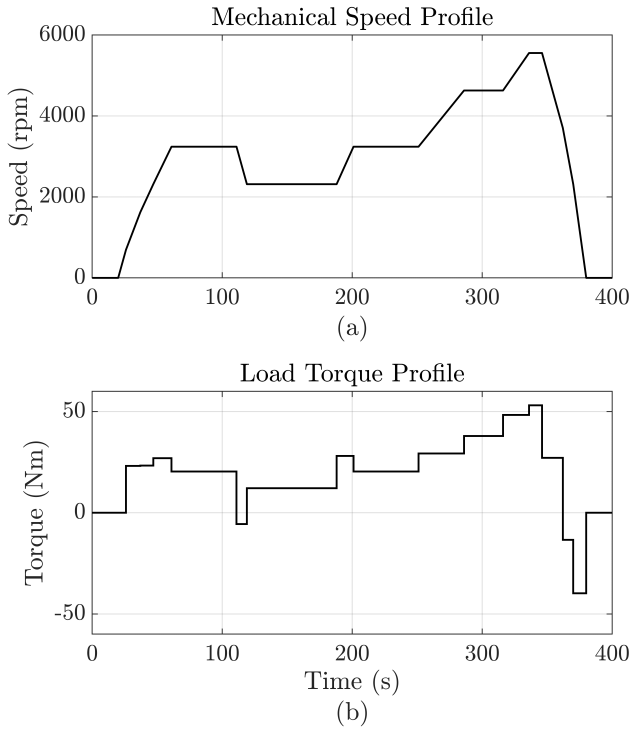

Fig. 9. Mission profile of the electric drive train with (a) Mechanical speed profile, and (b) Load torque profile.

inverter, and on-board charger) of an EV case study are investigated. The reliability performance of the electrical drive train power module is analyzed under a typical vehicle driving cycle profile (as shown in Fig. 8(a)), while the reliability of the electrolytic capacitor used in the EV on-board charger is studied according to a standard charging profile (as shown in Fig. 8(b)). The overall topology configurations of the electrical drive train main inverter and of the on-board EV charger, for the two selected sub-assemblies, are shown in Fig. 5 and Fig. 3, respectively.

A typical electrical drive train used to drive a fully electric battery-based electric vehicle is selected as study-case, and it is shown in Fig. 4. The mechanical power of the EV is generated by a 75 kW Permanent Magnet Synchronous Machine (PMSM), which is supplied by a 330 V high-voltage battery. The main parameters of the electrical machine are

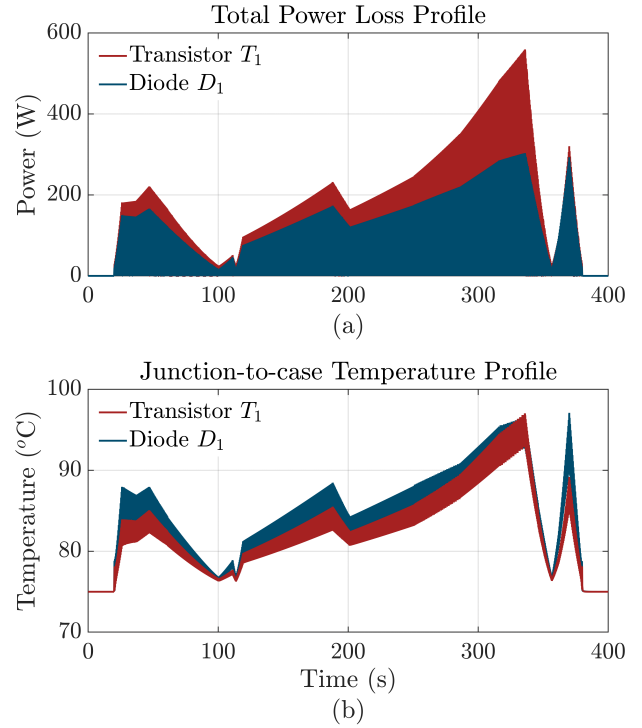

Fig. 10. Electro-thermal loading profiles of the drive train power semiconductor devices under the given mission profiles (a) Total power losses, and (b) Junction-to-case temperature for the drive train.

given in Table III. The interface between the battery and the motor is assured by the electronic power stack, which consists of the 300 μF/450 V film capacitor DC-link, and a three-phase 400 A/650 V IGBT power module fully qualified for automotive applications.

The above-mentioned mission-profile-based reliability assessment procedure is used to evaluate the lifetime estimation of the power semiconductor devices, and inherently of the power module, under the given Extra Urban Driving Cycle (EUDC) mission profile (Fig. 8(a)).

Initially, the driving cycle of the vehicle is converted into the mechanical power required by the PMSM. This is achieved through the vehicle's mathematical models, which take into account its mechanical parameters (e.g., mass, gear ratio, wheel radius, drag coefficient, etc.). The mechanical equations introduced in [90] (and their corresponding coefficients) have been employed, and the resulting speed and torque requirements of the PMSM are presented in Fig. 9.

Afterwards, similar to any typical motor drive application, the speed and torque profiles of the motor are used to determine the current flowing through each of the components of interest. This is achieved by modeling the drive systems and its control in the dq-reference frame. A detailed description of the electro-mechanical models for the PMSM and voltage source inverter is given in [84].

The resulting current and voltage loadings of the power semiconductor devices are then utilized using electro-thermal models. Average switching cycle power loss models [91, 92] are first used to calculate the total losses (e.g., switching losses and conduction losses) generated by the power semiconductor

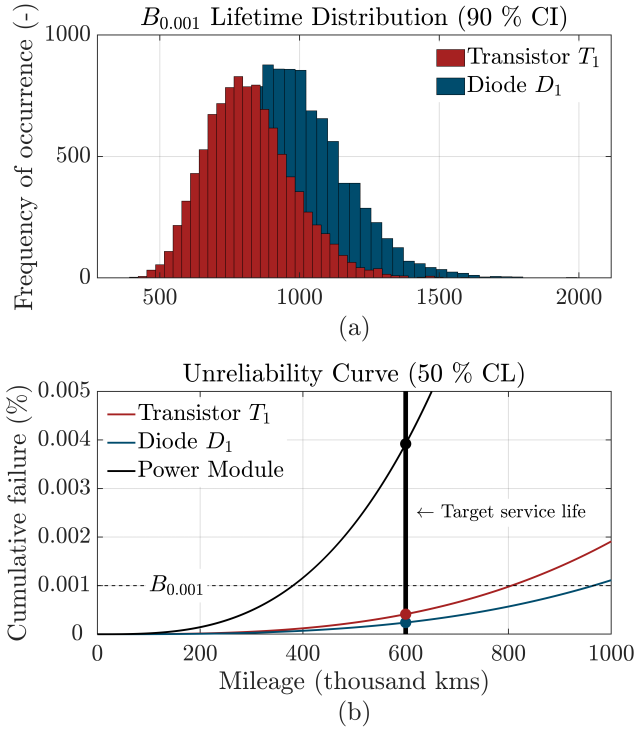

Fig. 11. Reliability metrics of the drive train IGBT power stage for the driving cycle (a) $B_{0.001}$ lifetime distribution with 90 % confidence interval (CI), and (b) Cumulative failure distribution of the B_x lifetime with 50 % confidence level (CL).

devices. Based on the loss characteristics provided by the IGBT power module manufacturer in the datasheet, the total power loss profile of the upper transistor/diode pair (T1/D1) is calculated and shown in Fig. 10(a). As expected, due to the limited braking/stop periods of the selected EUDC mission profile, the motor operates mainly in the motor-mode. Thus, more stress is focused on the transistor. Afterwards, the power loss profile is fed into the thermal models, where RC Foster thermal networks are used to determine the thermal loading behavior of the power devices [93]. The required thermal parameters (e.g., thermal resistance and thermal capacitance) are extracted from the power module datasheet as a four-level thermal network. However, due to the limited information regarding the outer thermal network of the IGBT module (e.g., thermal grease, case, coolant), only the junction-to-case temperature is modeled, while the coolant temperature is assumed to be 75 °C [70]. The resulting thermal behavior of the power semiconductor devices is shown in Fig. 10(b). Despite generating higher losses than the diode, the transistor exhibits a lower average temperature during the low-speed operation of the vehicle. This is mainly due to its thermal impedance characteristic, which is approximately twice as low as the thermal impedance of the diode.

To apply a lifetime model, the resulting junction temperature data needs to be represented in terms of thermal cycle amplitude, and thermal cycle mean value. This is done with the help of a Rainflow counting algorithm [94, 95]. Due to the lack of publicly available empirical lifetime models for automotive-qualified IGBT modules, the obtained thermal

cycle representation of the power device thermal stress is applied to the lifetime model proposed in the LESIT project [96, 97]. However, the given lifetime model is used to describe the general failure of IGBT modules at the 10 % lifetime percentile (B_{10} lifetime) with 50 % confidence. Because such a high probability of failure (e.g., 10 %) is not realistic for automotive applications, which expect failure rates in the ppm range, lower probabilities of failure (e.g., 0.001 % or lower) are required. By assuming the shape parameters of the Weibull distribution ($\beta = 3$), the Weibull cumulative distribution function (cdf) is used to estimate the lifetime of the power semiconductor devices at a lower probability of failure levels [5]. Additionally, to provide a more realistic lifetime estimation, the variations that might occur in the lifetime model coefficients need to be considered. Thus, by assuming a 5 % deviation in the lifetime model coefficients, a Monte Carlo simulation is used to calculate the lifetime distribution on the components of interest. The outcomes of the Monte Carlo analysis are shown in Fig. 11(a), where it can be noticed that the $B_{0.001}$ lifetime (0.001 % probability of failure) of the transistor is between approximately 500 and 1300 thousand kilometers, with a 90 % confidence interval. On the other hand, due to its lower thermal cycle amplitude, the diode seems to be less prone-to-failure, with a 0.001 % probability of failure ranging between approximately 600 and 1500 thousand kilometers.

Finally, the cumulative distribution function of the wear-out failure of the power semiconductors can be used to estimate the system-level reliability (e.g., IGBT power module). Assuming that all six transistors and all six diodes of the IGBT power module have the same reliability performance as the upper transistor/diode pair (T1/D1), the Reliability Block Diagram (RBD) analysis [98] is used to merge the reliability information of each device, and to calculate the unreliability curve of the IGBT power module. The outcomes of the RBD analysis are shown in Fig. 11(b). Considering a typical service life target of 600 thousand kilometers [43], the probability that the transistor and the diode fail before the target service life is approximately 0.0004 %, and 0.0002 %, respectively. On the other hand, at the assembly level, in the case of the entire power module, the probability of failure before the 600 thousand kilometers target is approximately 0.004 %.

A similar reliability modeling approach can be carried out for estimating the lifetime of a 560 μ F/400 V DC-link capacitor used in a 3.3 kW single-phase on-board charger, as shown in Fig. 3. The main parameters of the charging system are presented in Table IV.

The charging profile shown in Fig. 8(b) is used to calculate the capacitor's electrical and thermal loading [86, 99]. The resulting core-to-ambient temperature profile is then used to determine the capacitor's reliability metrics, under the given mission profiles. Considering the empirical lifetime model presented in [86], and a 5 % variation in its coefficients, the capacitor's B_1 lifetime distribution is calculated by Monte Carlo simulations. As shown in Fig. 12(a), the DC-link capacitor of the on-board charger has a 1 % probability of failure between 500 and 2500 thousand kilometers, with a 90 % confidence interval.

TABLE IV
PARAMETERS OF THE 3.3 kW ON-BOARD CHARGING SYSTEM

Parameter	Value
Input grid voltage	220 V
PFC inductance	130 μ H
PSFB leakage inductance	8 μ H
PSFB output inductance	400 μ H
PSFB output capacitance	33 μ F
Transformer turns ratio	12 : 16
DC-link voltage	400 V
DC-link capacitance	1.68 mF

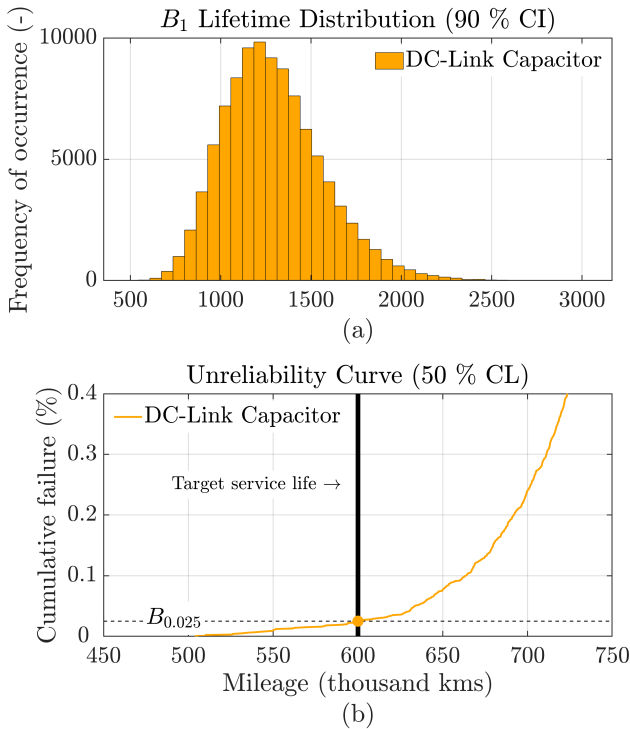

Fig. 12. Reliability metrics of the on-board charger DC-link capacitor (a) B₁ lifetime distribution with 90 % confidence interval (CI), and (b) Cumulative failure distribution of the B_x lifetime with 50 % confidence level (CL).

Finally, assuming the shape parameter of the Weibull distribution ($\beta = 3$), the cumulative distribution function (cdf) is needed to estimate the lifetime of the capacitor at other probabilities of failure than the one associated with the utilized lifetime model. Considering the same target service lifetime as for the drive train power module, it can be seen from Fig. 12(b) that the probability of the on-board charger DC-link capacitor failing before the 600 thousand kilometer target is approximately 0.025 %.

C. Reliability Design Guidelines and Implementation Approaches

Despite being a relatively straight-forward and fast approach for determining the critical reliability metrics of the EV/HEV

power electronic system, the results of the above-mentioned reliability assessment procedure are subject to many uncertainties.

As shown in [100]–[102], certain degrees of uncertainty can be introduced by various factors such as: environmental mission profiles, electro-thermal modeling, lifetime models, etc. The error margins introduced by the different modeling approaches can lead to significant deviations in the lifetime estimation, and reduce the confidence in the predicted result. Thus, before taking any reliability-related decisions and/or actions regarding the design of the power electronic system, one must be fully aware of the underlying assumptions and uncertainties behind the reliability metrics.

For cases in which many aspects of the system/reliability modeling are unknown and “rule-of-thumb” approximations need to be made, the above-mentioned mission-profile-based reliability assessment methodology can be used for relative lifetime prediction purposes. Thus, due to the high degree of uncertainty, the reliability metrics are not considered as direct lifetime indicators of the power electronic systems, but rather used in order to benchmark different solutions (e.g., control algorithms, system topologies, cooling methods, etc.). In this way, the impact of various solutions on the reliability of the power electronic system can be quantified, and thus, educated reliability-oriented design actions can be taken.

V. FUTURE RESEARCH DIRECTIONS

Research opportunities related to dealing with power electronics reliability challenges for EV and HEV applications are discussed below from three aspects of component technology, design and testing method, and operation management.

A. Component Technology

The increasing EV and HEV market paves the way to bring new resources and strong motivations to advance further science and technology in power semiconductors, capacitors, and converter-level interconnects. Due to the harsh environment, high-temperature power electronic components enable improved reliability and reduced cooling requirements. Vibration-robust component packaging and interconnect design are also relevant research areas.

B. Design and Testing Methods

Design to build reliability into power electronic converters is the first layer to fulfill reliability aspects specifications. Design methodologies, such as design for reliability and digital-twin based design, could create promising added values. Research is needed to develop relevant multi-physics models, digital design procedures and platforms.

There is a continuous demand for reducing the time required for accelerated degradation testing, and reliability demonstration testing. New testing concepts and methods are needed. Virtual-physical hybrid testing methods and accelerated testing methods combined with early wear out prediction model could be promising directions. In a recent case study on battery testing presented in [103], it demonstrates that the required time for identifying high-cycle-life charging protocols among

224 candidates is reduced to 3.2 % of the expected time without early-prediction. It is worth exploring the application of such concept into other accelerated degradation testing methods for other types of electronic components.

C. Condition Monitoring and Operation Management

Smart control and condition monitoring of power converters are the second layer to ensure reliability and availability in field operation. Control strategies that can adapt to the in-situ mission profile to optimize the electrical and thermal performance could bring additional benefits by leveraging the capability of digital controllers. With the demand for high-reliability power electronic converters in automotive applications, a failure-free operation may become a requirement for many applications. If failure is not an option, the understanding of the degradation process becomes important. Condition monitoring becomes an even more important tool in reliability engineering if failure is not allowed within the service life. Degradation modeling helps to predict the time for maintenances. Robust and cost-effective condition monitoring methods are demanded. Even though a wide range of health precursors and implementations have been proposed in literature, the fact is that they are rarely adopted in field operation, both for power semiconductors and capacitors. Complexity, cost, converter-level design constraints and accessibility, and effectiveness under field operation environment are of great concern.

D. Understanding and Modeling for Multi-Components and Multi-Stressors

This paper mainly focuses on thermal-related failures of power semiconductor devices and capacitors. Nevertheless, in-depth understanding of other types of components such as interconnects, PCBs, cooling assemblies, etc., and other stressors such as humidity, vibration, and shock, is needed. Moreover, the methods for the reliability aspect investigations for the power stage and low-power control and signal-conditioning stage could be different, due to different dominant failure mechanisms, critical stressors, standardization, and modularity of components.

VI. CONCLUSIONS

The power electronics is an essential technology for EV and HEV. Its design and implementation are essential, especially the reliability is a success-criteria for the penetration of EV/HEV. Many power electronic components are applied and design for reliability and predictive maintenance programs can make such systems highly reliable. This paper gives a broad overview of power electronic architectures in EV/HEV, where also the reliability requirements are specified. Some of them are already given in standards while others are needed. It can though be concluded that still reliability challenges will continue to come as the technology is evolving. In the power electronics the first condition for evolution is component development. The paper highlights issues related to capacitors and active devices but also in respect to cooling aspects to make the power electronic systems reliable and safe. At the system level, reliability-oriented design is a key to reduce/optimize cost combined with the possibility of

condition monitoring when an EV/HEV fleet is operating. Multi-disciplinary simulation tools are essential to a proper design for reliability, which is demonstrated in two case studies in the paper. Some of the future challenges and research opportunities are more widely use of wide bandgap devices to reduce size and increase power density, overall system control during life operation where reliability indexes of the parts are used to make decision about system operation, make better packaging technologies incl. thermal management as well as handling large data dynamically and pro-actively in terms of preventive maintenance.

REFERENCES

- [1] F. Blaabjerg, Y. Yang, D. Yang, and X. Wang, "Distributed power-generation systems and protection," *Proc. IEEE*, vol. 105, no. 7, pp. 1311–1331, 2017.
- [2] G. Knappik and J. Schwab, "The advantages of 48-volt vehicle electronics," *Vehicle Technology*, pp. 1–5, 2019.
- [3] U. Kramer, "Defossilizing the transportation sector – options and requirements for germany," *FVV, Germany*, pp. 1–112, 2018.
- [4] Bloomberg, "Electrical vehicles outlook 2020," 2020.
- [5] P. O'Connor and A. Kleynner, *Practical reliability engineering*. John Wiley & Sons, 2012.
- [6] M. R. Lyu *et al.*, *Handbook of software reliability engineering*. IEEE computer society press CA, 1996, vol. 222.
- [7] K. Ma, H. Wang, and F. Blaabjerg, "New approaches to reliability assessment: Using physics-of-failure for prediction and design in power electronics systems," *IEEE Power Electron. Mag.*, vol. 3, no. 4, pp. 28–41, 2016.
- [8] M. Pecht and A. Dasgupta, "Physics-of-failure: An approach to reliable product development," *Journal of the IES*, vol. 38, no. 5, pp. 30–34, 1995.
- [9] S. Yang, A. Bryant, P. Mawby, D. Xiang, L. Ran, and P. Tavner, "An industry-based survey of reliability in power electronic converters," *IEEE Trans. Ind. Appl.*, vol. 47, no. 3, pp. 1441–1451, 2011.
- [10] H. Wang, M. Liserre, and F. Blaabjerg, "Toward reliable power electronics: Challenges, design tools, and opportunities," *IEEE Ind. Electron. Mag.*, vol. 7, no. 2, pp. 17–26, 2013.
- [11] H. Wang, M. Liserre, F. Blaabjerg, P. de Place Rimmens, J. B. Jacobsen, T. Kvisgaard, and J. Landkildehus, "Transitioning to physics-of-failure as a reliability driver in power electronics," *IEEE J. Emerg. Sel. Topics Power Electron.*, vol. 2, no. 1, pp. 97–114, 2014.
- [12] F. B. Henry Shu-Hung Chung Huai Wang and M. Pecht, *Reliability of power electronic converter systems*. Institution of Engineering and Technology, 2015, vol. 80.
- [13] C. Durand, M. Klingler, D. Coutellier, and H. Naceur, "Power cycling reliability of power module: A survey," *IEEE Trans. Device Mater. Rel.*, vol. 16, no. 1, pp. 80–97, 2016.
- [14] N. Baker, M. Liserre, L. Dupont, and Y. Avenas, "Improved reliability of power modules: A review of online junction temperature measurement methods," *IEEE Ind. Electron. Mag.*, vol. 8, no. 3, pp. 17–27, 2014.
- [15] Y. Avenas, L. Dupont, N. Baker, H. Zara, and F. Barruel, "Condition monitoring: A decade of proposed techniques," *IEEE Ind. Electron. Mag.*, vol. 9, no. 4, pp. 22–36, 2015.
- [16] H. Oh, B. Han, P. McCluskey, C. Han, and B. D. Youn, "Physics-of-failure, condition monitoring, and prognostics of insulated gate bipolar transistor modules: A review," *IEEE Trans. Power Electron.*, vol. 30, no. 5, pp. 2413–2426, 2015.
- [17] R. Khazaka, L. Mendizabal, D. Henry, and R. Hanna, "Survey of high-temperature reliability of power electronics packaging components," *IEEE Trans. Power Electron.*, vol. 30, no. 5, pp. 2456–2464, 2015.
- [18] H. Lee, V. Smet, and R. Tummala, "A review of sic power module packaging technologies: Challenges, advances, and emerging issues," *IEEE J. Emerg. Sel. Topics Power Electron.*, vol. 8, no. 1, pp. 239–255, 2020.
- [19] Z. Ni, X. Lyu, O. P. Yadav, B. N. Singh, S. Zheng, and D. Cao, "Overview of real-time lifetime prediction and extension for sic power converters," *IEEE Trans. Power Electron.*, vol. 35, no. 8, pp. 7765–7794, 2020.

- [20] H. Wang and F. Blaabjerg, "Reliability of capacitors for dc-link applications in power electronic converters-an overview," *IEEE Trans. Ind. Appl.*, vol. 50, no. 5, pp. 3569–3578, 2014.
- [21] "Handbook for robustness validation of semiconductor devices in automotive applications," ZVEI - Zentralverband Elektrotechnik- und Elektronikindustrie, German Electrical and Electronic Manufacturers Association, Third edition, Tech. Rep., 2015.
- [22] "Reliability prediction for automotive electronics based on field return data," J3083 201703, SAE International, Tech. Rep., 2017.
- [23] A. Khaligh and M. D'Antonio, "Global trends in high-power on-board chargers for electric vehicles," *IEEE Trans. Veh. Technol.*, vol. 68, no. 4, pp. 3306–3324, 2019.
- [24] J. Schafer, D. Bortis, and J. W. Kolar, "Multi-port multi-cell dc/dc converter topology for electric vehicle's power distribution networks," Stanford, CA: IEEE, 2017, pp. 1–9.
- [25] J. Drobnik and P. Jain, "Electric and hybrid vehicle power electronics efficiency, testing and reliability," Barcelona: IEEE, 2013, pp. 1–12.
- [26] Ehsani, *Modern Electric, Hybrid Electric, and Fuel Cell Vehicles*.
- [27] Mi, *Hybrid Electric Vehicles: Principles and Applications with Practical Perspectives*.
- [28] A. Emadi, Y. J. Lee, and K. Rajashekara, "Power electronics and motor drives in electric, hybrid electric, and plug-in hybrid electric vehicles," *IEEE Trans. Ind. Electron.*, vol. 55, no. 6, pp. 2237–2245, 2008.
- [29] S. Standard, *Sae electric vehicle and plug-in hybrid electric vehicle conductive charge coupler*, 2010.
- [30] G. R. C. Mouli, P. Venugopal, and P. Bauer, "Future of electric vehicle charging," in *Proc. Int. Symp. Power Electronics (Ee)*, 2017, pp. 1–7.
- [31] B. Li, Q. Li, F. C. Lee, Z. Liu, and Y. Yang, "A high-efficiency high-density wide-bandgap device-based bidirectional on-board charger," *IEEE J. Emerg. Sel. Topics Power Electron.*, vol. 6, no. 3, pp. 1627–1636, 2018.
- [32] T. Friedli, M. Hartmann, and J. W. Kolar, "The essence of three-phase pfc rectifier systems—part ii," *IEEE Trans. Power Electron.*, vol. 29, no. 2, pp. 543–560, 2014.
- [33] Infineon. (2018). Shaping future electromobility with semiconductor innovations, [Online]. Available: https://www.mouser.com/pdfdocs/Infineon_Electric_Cars.pdf.
- [34] F. Krismer, "Modeling and optimization of bidirectional dual active bridge dc-dc converter topologies," PhD thesis, ETH Zurich, 2010.
- [35] F. Krismer and J. W. Kolar, "Efficiency-optimized high-current dual active bridge converter for automotive applications," *IEEE Trans. Ind. Electron.*, vol. 59, no. 7, pp. 2745–2760, 2012.
- [36] B. Liu, P. Davari, and F. Blaabjerg, "Nonlinear coss-vds profile based ZVS range calculation for dual active bridge converters," *IEEE Trans. Power Electron.*, vol. 36, no. 1, pp. 45–50, 2021.
- [37] B. Liu, P. Davari, and F. Blaabjerg, "An optimized hybrid modulation scheme for reducing conduction losses in dual active bridge converters," *IEEE J. Emerg. Sel. Topics Power Electron.*, pp. 1–1, 2019.
- [38] UK. (2018). The roadmap report, towards 2040: A guide to automotive propulsion technologies, Advanced Propulsion Centre UK, 2018, [Online]. Available: <https://www.apcuk.co.uk/app/uploads/2018/06/roadmap-report-26-6-18.pdf>.
- [39] O. Wittler, "Lifetime modeling strategies in the context of automotive requirements," ECPE workshop, Reliability Engineering 10 Years Robustness Validation, Tech. Rep., 2018.
- [40] "Vw 80000: Electric and electronic components in motor vehicles up to 3,5t," General Requirements Test Conditions and Test standard, Tech. Rep., 2013.
- [41] "Vorlesung: Qualitat und zuverlassigkeit von fahrzeug e/e hardware an der tu berlin," Tech. Rep., 2008.
- [42] US. (2017). Electrical and electronics technical team roadmap, U.S. DRIVE Department of Energy, 2017, [Online]. Available: <https://www.energy.gov/sites/prod/files/2017/11/f39/EETT%20Roadmap%2010-27-17.pdf>.
- [43] "Zvei: Die elektroindustrie, handbook for robustness validation of automotive electrical/electronic modules," German Electrical and Electronics Manufacturer Association, Tech. Rep., 2013.
- [44] "Aec q200: Stress test qualification for passive components, rev d," Automotive Electronic Council, Tech. Rep., 2010.
- [45] "Aec q101: Failure mechanism based stress test qualification for discrete semiconductors in automotive applications, rev d1," Automotive Electronic Council, Tech. Rep., 2013.
- [46] B. Bilgin, P. Magne, P. Malysz, Y. Yang, V. Pantelic, M. Preindl, A. Korobkine, W. Jiang, M. Lawford, and A. Emadi, "Making the case for electrified transportation," *IEEE Trans. Transport. Electrific.*, vol. 1, no. 1, pp. 4–17, 2015.
- [47] J. Reimers, L. Dorn-Gomba, C. Mak, and A. Emadi, "Automotive traction inverters: Current status and future trends," *IEEE Trans. Veh. Technol.*, vol. 68, no. 4, pp. 3337–3350, 2019.
- [48] Z. Q. Zhu and D. Howe, "Electrical machines and drives for electric, hybrid, and fuel cell vehicles," *Proc. IEEE*, vol. 95, no. 4, pp. 746–765, 2007.
- [49] Z. Wang, B. Liu, L. Guan, Y. Zhang, M. Cheng, B. Zhang, and L. Xu, "A dual-channel magnetically integrated EV chargers based on double-stator-winding permanent-magnet synchronous machines," *IEEE Trans. Ind. Appl.*, vol. 55, no. 2, pp. 1941–1953, Mar. 2019.
- [50] N. Pavliček, C. Liu, J. Loisy, G. Salvatore, F. Mohn, J. Schuderer, A. Apelsmeier, F. Dresel, A. Schletz, and S. Vater, "Power module platform for automotive reliability requirements," in *Proc. 21st European Conf. Power Electronics and Applications (EPE '19 ECCE Europe)*, 2019, P.1–P.10.
- [51] U. Scheuermann, "Reliability challenges of automotive power electronics," *Microelectron. Reliab.*, vol. 49, no. 9-11, pp. 1319–1325, 2009.
- [52] P. Kumar Prasobhu, V. Raveendran, G. Buticchi, and M. Liserre, "Active thermal control of GaN-based DC/dc converter," *IEEE Trans. Ind. Appl.*, vol. 54, no. 4, pp. 3529–3540, 2018.
- [53] M. Andresen, G. De Carne, and M. Liserre, "Load-dependent active thermal control of grid-forming converters," *IEEE Trans. Ind. Appl.*, vol. 56, no. 2, pp. 2078–2086, 2020.
- [54] C. H. van der Broeck, L. A. Ruppert, R. D. Lorenz, and R. W. De Doncker, "Methodology for active thermal cycle reduction of power electronic modules," *IEEE Trans. Power Electron.*, vol. 34, no. 8, pp. 8213–8229, 2019.
- [55] L. Wei, J. McGuire, and R. A. Lukaszewski, "Analysis of PWM frequency control to improve the lifetime of PWM inverter," *IEEE Trans. Ind. Appl.*, vol. 47, no. 2, pp. 922–929, 2011.
- [56] D. A. Murdock, J. E. R. Torres, J. J. Connors, and R. D. Lorenz, "Active thermal control of power electronic modules," *IEEE Trans. Ind. Appl.*, vol. 42, no. 2, pp. 552–558, 2006.
- [57] N. Seliger, E. Wolfgang, G. Lefranc, H. Berg, and T. Licht, "Reliable power electronics for automotive applications," *Microelectron. Reliab.*, vol. 42, no. 9-11, pp. 1597–1604, 2002.
- [58] P. Drexhage, "Effect of humidity and condensation on power electronics systems," *Semikron Application Note NA*, pp. 16–001, 2016.
- [59] V. Verdingovas, "Climatic reliability of electronics: Early prediction and control of contamination and humidity effects," PhD thesis, Technical University of Denmark, 2015.
- [60] A. Teverovsky, "Cracking problems in low-voltage chip ceramic capacitors," NASA Electronic Parts and Packaging (NEPP) Program, Tech. Rep., 2019.
- [61] "Aqg 324: Qualification of power modules for use in power electronics converter units in motor vehicles," Edition 02.1, ECPE Guideline, Tech. Rep., 2019.
- [62] C. Herold, J. Sun, P. Seidel, L. Tinschert, and J. Lutz, "Power cycling methods for SiC mosfets," in *Proc. 29th Int. Symp. Power Semiconductor Devices and IC's (ISPSD)*, 2017, pp. 367–370.
- [63] M. Andresen, M. Liserre, and G. Buticchi, "Review of active thermal and lifetime control techniques for power electronic modules," in *Proc. 16th European Conf. Power Electronics and Applications*, 2014, pp. 1–10.
- [64] T. Krebs, S. Duch, W. Schmitt, S. Katter, P. Prenosil, and S. Thomas, "A breakthrough in power electronics reliability - new die attach and wire bonding materials," Las Vegas, NV: IEEE, 2013, pp. 1746–1752.
- [65] S. Haumann, J. Rudzki, F. Osterwald, M. Becker, and R. Eisele, "Novel bonding and joining technology for power electronics - enabler for improved lifetime, reliability, cost and power density," Long Beach, CA: IEEE, 2013, pp. 622–626.
- [66] M. Ishihara, K. Hiyama, K. Yamada, T. Radke, M. Honsberg, and T. Nakano, "New transfer-mold power module series for automotive power-train inverters," in *PCIM Europe*, 2012, pp. 1408–1413.
- [67] M. Ishihara, N. Miyamoto, K. Hiyama, T. Radke, and T. Nakano, "New compact-package power modules for electric and hybrid vehicles (j1 series)," in *PCIM Europe*, 2014, pp. 1093–1097.
- [68] T. Kimura, R. Saitou, K. Kubo, K. Nakatsu, H. Ishikawa, and K. Sasaki, "High-power-density inverter technology for hybrid and electric vehicle applications," *Hitachi Review*, vol. 63, no. 2, pp. 41–46, 2014.
- [69] Y. Wang, X. Dai, G. Liu, Y. Wu, D. Li, and S. Jones, "Integrated liquid cooling automotive IGBT module for high temperatures coolant application," in *Proc. PCIM Europe 2015; Int. Exhibition and Conf. for Power Electronics, Intelligent Motion Renewable Energy and Energy Management*, 2015, pp. 1–7.

- [70] Y. Wang, S. Jones, A. Dai, and G. Liu, "Reliability enhancement by integrated liquid cooling in power igbt modules for hybrid and electric vehicles," *Microelectron. Reliab.*, vol. 54, no. 9-10, pp. 1911–1915, 2014.
- [71] A. Christmann, M. Thoben, and K. Mainka, "Reliability of power modules in hybrid vehicles," in *PCIM Europe*, 2009, pp. 359–366.
- [72] K. Higuchi, A. Kitamura, H. Arai, T. Ichimura, H. Gohara, P. Dietrich, and A. Nishiura, "An intelligent power module with high accuracy control system and direct liquid cooling for hybrid system," in *PCIM Europe 2014; International Exhibition and Conference for Power Electronics, Intelligent Motion, Renewable Energy and Energy Management*, VDE, 2014, pp. 1–8.
- [73] A. Allouche and V. L. Troade. (2020). Hitachi dsc power module from audi e-tron inverter, [Online]. Available: https://www.systemplus.fr/wp-content/uploads/2020/01/SP20516-Hitachi-Power-Module-Audi-e-tron-Inverter_flyer.pdf.
- [74] L. Qi, L. Petersson, and T. Liu, "Review of recent activities on dielectric films for capacitor applications," *Journal of International Council on Electrical Engineering*, vol. 4, no. 1, pp. 1–6, 2014.
- [75] J. Stewart, J. Neely, J. Delhotal, and J. Flicker, "DC link bus design for high frequency, high temperature converters," in *Proc. IEEE Applied Power Electronics Conf. and Exposition (APEC)*, 2017, pp. 809–815.
- [76] I. Vernica, H. Wang, and F. Blaabjerg, "A mission-profile-based tool for the reliability evaluation of power semiconductor devices in hybrid electric vehicles," in *Proc. 32nd Int. Symp. Power Semiconductor Devices and ICs (ISPSD)*, 2020, pp. 380–383.
- [77] Y. Wang, X. Dai, G. Liu, Y. Wu, Y. Li, and S. Jones, "Status and trend of power semiconductor module packaging for electric vehicles," *Modeling and Simulation for Electric Vehicle Applications*, p. 23, 2016.
- [78] D. L. Saums and C. I. Center, "Application of metallic tims for harsh environments and non-flat surfaces," *Thermal Management of Onboard Charger in E-Vehicles Reliability of Nano-sintered Silver Die Attach Materials Thermal Energy Harvesting with*, p. 20, 2017.
- [79] C. Mi, F. Z. Peng, K. J. Kelly, M. O'Keefe, and V. Hassani, "Topology, design, analysis and thermal management of power electronics for hybrid electric vehicle applications," *Int. J. Electr. Hybrid Veh.*, vol. 1, no. 3, pp. 276–294, 2008.
- [80] T. J. BARLOW, S. Latham, I. McCrae, and P. Boulter, "A reference book of driving cycles for use in the measurement of road vehicle emissions," *TRL Published Project Report*, 2009.
- [81] M. S. Islam and N. Mithulananthan, "Daily ev load profile of an ev charging station at business premises," in *2016 IEEE Innovative Smart Grid Technologies-Asia (ISGT-Asia)*, IEEE, 2016, pp. 787–792.
- [82] H. Wang and F. Blaabjerg, "Power electronics reliability- state of the art and outlooks," *IEEE J. Emerg. Sel. Topics Power Electron.*, 2020.
- [83] K. Ma, D. Zhou, and F. Blaabjerg, "Evaluation and design tools for the reliability of wind power converter system," *J. Power Electron.*, vol. 15, no. 5, pp. 1149–1157, 2015.
- [84] K. Ma, M. Liserre, F. Blaabjerg, and T. Kerekes, "Thermal loading and for power device considering mission profiles in wind power converter," *IEEE Trans. Power Electron.*, vol. 30, no. 2, pp. 590–602, 2015.
- [85] A. Sangwongwanich, Y. Yang, D. Sera, and F. Blaabjerg, "Lifetime evaluation of grid-connected PV inverters considering panel degradation rates and installation sites," *IEEE Trans. Power Electron.*, vol. 33, no. 2, pp. 1225–1236, 2018.
- [86] H. Wang, P. Davari, H. Wang, D. Kumar, F. Zare, and F. Blaabjerg, "Lifetime estimation of DC-link capacitors in adjustable speed drives under grid voltage unbalances," *IEEE Trans. Power Electron.*, vol. 34, no. 5, pp. 4064–4078, 2019.
- [87] R. Burgos, G. Chen, F. Wang, D. Boroyevich, W. G. Odendaal, and J. D. Van Wyk, "Reliability-oriented design of three-phase power converters for aircraft applications," *IEEE Trans. Aerosp. Electron. Syst.*, vol. 48, no. 2, pp. 1249–1263, 2012.
- [88] D. Hirschmann, D. Tissen, S. Schroder, and R. W. De Doncker, "Reliability prediction for inverters in hybrid electrical vehicles," *IEEE Trans. Power Electron.*, vol. 22, no. 6, pp. 2511–2517, 2007.
- [89] A. T. Bryant, P. A. Mawby, P. R. Palmer, E. Santi, and J. L. Hudgins, "Exploration of power device reliability using compact device models and fast electrothermal simulation," *IEEE Trans. Ind. Appl.*, vol. 44, no. 3, pp. 894–903, 2008.
- [90] A. Soldati, G. Pietrini, M. Dalboni, and C. Concarì, "Electric-vehicle power converters model-based design-for-reliability," *CPSS Transactions on Power Electronics and Applications*, vol. 3, no. 2, pp. 102–110, 2018.
- [91] K. Ma, A. S. Bahman, S. Beczkowski, and F. Blaabjerg, "Complete loss and thermal model of power semiconductor including device rating information," *IEEE Trans. Power Electron.*, vol. 30, no. 5, pp. 2556–2569, 2015.
- [92] M. Musallam, C. Yin, C. Bailey, and M. Johnson, "Mission profile-based reliability design and real-time life consumption estimation in power electronics," *IEEE Trans. Power Electron.*, vol. 30, no. 5, pp. 2601–2613, 2015.
- [93] K. Ma, N. He, M. Liserre, and F. Blaabjerg, "Frequency-domain thermal modeling and characterization of power semiconductor devices," *IEEE Trans. Power Electron.*, vol. 31, no. 10, pp. 7183–7193, 2016.
- [94] A. C. E.-. on Fatigue and Fracture, *Standard practices for cycle counting in fatigue analysis*. ASTM International, 2005.
- [95] M. Musallam and C. M. Johnson, "An efficient implementation of the rainflow counting algorithm for life consumption estimation," *IEEE Trans. Rel.*, vol. 61, no. 4, pp. 978–986, 2012.
- [96] M. Held, P. Jacob, G. Nicoletti, P. Scacco, and M.-. Poech, "Fast power cycling test of IGBT modules in traction application," in *Proc. Second Int. Conf. Power Electronics and Drive Systems*, vol. 1, 1997, 425–430 vol.1.
- [97] A. Wintrich, U. Nicolai, W. Tursky, and T. Reimann, "Application manual power semiconductor. semikron international gmbh," ed: *ISLE Verlag, Illmenau*, 2011.
- [98] D. Zhou, H. Wang, and F. Blaabjerg, "Mission profile based system-level reliability analysis of DC/dc converters for a backup power application," *IEEE Trans. Power Electron.*, vol. 33, no. 9, pp. 8030–8039, 2018.
- [99] Y. Wang, X. Dai, G. Liu, Y. Wu, Y. Li, and S. Jones, "Status and trend of power semiconductor module packaging for electric vehicles," *Modeling and Simulation for Electric Vehicle Applications*, p. 23, 2016.
- [100] I. Vernica, H. Wang, and F. Blåbjerg, "Uncertainties in the lifetime prediction of igbts for a motor drive application," in *2018 IEEE International Power Electronics and Application Conference and Exposition (PEAC)*, IEEE, 2018, pp. 1–6.
- [101] I. Vernica, H. Wang, and F. Blaabjerg, "Impact of long-term mission profile sampling rate on the reliability evaluation of power electronics in photovoltaic applications," in *Proc. IEEE Energy Conversion Congress and Exposition (ECCE)*, 2018, pp. 4078–4085.
- [102] I. Vernica, U. M. Choi, H. Wang, and F. Blaabjerg, "Wear-out failure of an igbt module in motor drives due to uneven thermal impedance of power semiconductor devices," *Microelectron. Rel.*, 2020.
- [103] P. M. Attia, A. Grover, N. Jin, K. A. Severson, T. M. Markov, Y.-H. Liao, M. H. Chen, B. Cheong, N. Perkins, Z. Yang, et al., "Closed-loop optimization of fast-charging protocols for batteries with machine learning," *Nature*, vol. 578, no. 7795, pp. 397–402, 2020.



Frede Blaabjerg (S'86–M'88–SM'97–F'03) was with ABB-Scandia, Randers, Denmark, from 1987 to 1988. From 1988 to 1992, he got the PhD degree in Electrical Engineering at Aalborg University in 1995. He became an Assistant Professor in 1992, an Associate Professor in 1996, and a Full Professor of power electronics and drives in 1998. From 2017 he became a Villum Investigator. He is honoris causa at University Politehnica Timisoara (UPT), Romania and Tallinn Technical University (TTU) in Estonia.

His current research interests include power electronics and its applications such as in wind turbines, PV systems, reliability, harmonics and adjustable speed drives. He has published more than 600 journal papers in the fields of power electronics and its applications. He is the co-author of four monographs and editor of ten books in power electronics and its applications.

He has received 32 IEEE Prize Paper Awards, the IEEE PELS Distinguished Service Award in 2009, the EPE-PEMC Council Award in 2010, the IEEE William E. Newell Power Electronics Award 2014, the Villum Kann Rasmussen Research Award 2014, the Global Energy Prize in 2019 and the 2020 IEEE Edison Medal. He was the Editor-in-Chief of the IEEE TRANSACTIONS ON POWER ELECTRONICS from 2006 to 2012. He has been Distinguished Lecturer for the IEEE Power Electronics Society from 2005 to 2007 and for the IEEE Industry Applications Society from 2010 to 2011 as well as 2017 to 2018. In 2019-2020 he serves a President of IEEE Power Electronics Society. He is Vice-President of the Danish Academy of Technical Sciences too. He is nominated in 2014-2019 by Thomson Reuters to be between the most 250 cited researchers in Engineering in the world.



Bochen Liu (S'18) received his B.S. and M.S. degrees in electrical engineering and power electronics from Southeast University, Nanjing, China, in 2014 and 2017, respectively. He is currently working toward the Ph.D. degree in power electronics at Aalborg University, Aalborg, Denmark.

He was a student visitor with the University of Cambridge, UK, in 2020. His current research interests include thermal management and multi-objective optimization of dc-dc converters, and applications of power electronics on electric vehicles.



Huai Wang (M'12, SM'17) received the B.E. degree in electrical engineering, from Huazhong University of Science and Technology, Wuhan, China, in 2007 and the Ph.D. degree in power electronics, from the City University of Hong Kong, Hong Kong, in 2012. He is currently Professor with the Center of Reliable Power Electronics (CORPE), Department of Energy Technology at Aalborg University, Denmark. He was a Visiting Scientist with the ETH Zurich, Switzerland, from Aug. to Sep. 2014, and with the Massachusetts Institute of Technology (MIT), USA,

from Sep. to Nov. 2013. He was with the ABB Corporate Research Center, Switzerland, in 2009. His research addresses the fundamental challenges in modelling and validation of power electronic component failure mechanisms, and application issues in system-level predictability, condition monitoring, circuit architecture, and robustness design.

Dr. Wang received the Richard M. Bass Outstanding Young Power Electronics Engineer Award from the IEEE Power Electronics Society in 2016, and the Green Talents Award from the German Federal Ministry of Education and Research in 2014. He is currently the Chair of IEEE PELS/IAS/IES Chapter in Denmark. He serves as an Associate Editor of IET Electronics Letters, IEEE JOURNAL OF EMERGING AND SELECTED TOPICS IN POWER ELECTRONICS, and IEEE TRANSACTIONS ON POWER ELECTRONICS.



Pooya Davari (S'11–M'13–SM'19) received the B.Sc. and M.Sc. degrees in electronic engineering from University of Mazandaran (Noushivani), Iran, in 2004 and 2008, respectively, and the Ph.D. degree in power electronics from QUT, Australia, in 2013. From 2005 to 2010, he was involved in several electronics and power electronics projects as a Development Engineer. From 2013 to 2014, he was with QUT, as a Lecturer. He joined Aalborg University, in 2014, as a Postdoc, where he is currently an Associate Professor.

He has been focusing on EMI, power quality and harmonic mitigation analysis and control in power electronic systems. He has published more than 140 technical papers. Dr. Davari served as a Guest Associate Editor of IET Journal of Power Electronics, IEEE Access Journal, Journal of Electronics and Journal of Applied Sciences. He is an Associate Editor of Journal of Power Electronics, Associate Editor of IET Electronics, Editorial board member of EPE journal and Journal of Applied Sciences. He is member of the International Scientific Committee (ISC) of EPE (ECCE Europe) and a member of Joint Working Group six and Working Group eight at the IEC standardization TC77A. Dr. Davari is the recipient of a research grant from the Danish Council of Independent Research (DFR-FTP) in 2016, and 2020 IEEE EMC Society Young Professional Award for his contribution to EMI and Harmonic Mitigation and Modeling in Power Electronic Applications. He is currently Editor-in-Chief of Circuit World Journal.



Ionut Vernica (S'16, M'19) received the B.Sc. degree in electrical engineering from Politehnica University of Bucharest, Bucharest, Romania, in 2014. He received the M.Sc. and Ph.D. degrees in energy engineering from Aalborg University, Aalborg, Denmark, in 2016 and 2019, respectively.

Since October 2019, he has been with the Department of Energy Technology, Aalborg University, where he is currently employed as a Postdoctoral Researcher working on several industrial collaboration projects related to the reliability of power electronic systems. He was a visiting researcher with Grundfos A/S, Bjerringbro, Denmark, and Danfoss Drives A/S, Gråsten, Denmark, from January to April 2019. His current research interests include reliability of IGBT power modules and capacitors, thermal management of power devices, electric vehicle applications and the design automation of power electronic systems.

Dr. Vernica is the recipient of the "Best Originality Award" at the TECO Green Tech International Contest, Taipei, Taiwan, in 2019.