



**AALBORG UNIVERSITY**  
DENMARK

**Aalborg Universitet**

## **Large Eddy Simulation of Sydney Swirl Non-Reaction Jets**

Yang, Yang; Kær, Søren Knudsen; Yin, Chungen

*Publication date:*  
2010

*Document Version*  
Accepted author manuscript, peer reviewed version

[Link to publication from Aalborg University](#)

*Citation for published version (APA):*

Yang, Y., Kær, S. K., & Yin, C. (2010). *Large Eddy Simulation of Sydney Swirl Non-Reaction Jets*. Paper presented at Fifth European Conference on Computational Fluid Dynamics, Lisbon, Portugal.

### **General rights**

Copyright and moral rights for the publications made accessible in the public portal are retained by the authors and/or other copyright owners and it is a condition of accessing publications that users recognise and abide by the legal requirements associated with these rights.

- ? Users may download and print one copy of any publication from the public portal for the purpose of private study or research.
- ? You may not further distribute the material or use it for any profit-making activity or commercial gain
- ? You may freely distribute the URL identifying the publication in the public portal ?

### **Take down policy**

If you believe that this document breaches copyright please contact us at [vbn@aub.aau.dk](mailto:vbn@aub.aau.dk) providing details, and we will remove access to the work immediately and investigate your claim.

## **LARGE EDDY SIMULATION OF SYDNEY SWIRL NON-REACTION JETS**

**Yang Yang, Søren Knudsen Kær and Chungen Yin**

Department of Energy Technology  
Aalborg University, Pontoppidanstræde 101, 9220 Aalborg, Denmark

e-mail: {yya,skk,chy}@iet.aau.dk

**Key words:** Large eddy simulation, Sydney swirl burner, Spectral characteristic

**Abstract.** *The Sydney swirl burner non-reaction case was studied using large eddy simulation. The two-point correlation method was introduced and used to estimate grid resolution. Energy spectra and instantaneous pressure and velocity plots were used to identify features in flow field. By using these methods, vortex breakdown and precessing vortex core are identified and different flow zones are shown.*

## 1 INTRODUCTION

Swirl flow devices can be seen in many reactors, separators, whirlpools, agricultural spraying machines, and so on. In combustion systems, the swirl devices are usually used to stabilize the flame and shorten its length, increase the mixing of fuel and oxidant, control formation of harmful emissions, and increase the life of system.

At certain Reynolds numbers, when swirl number around 0.6, high swirl flow can generate a large radial pressure gradient due to the centrifugal effects. Strong coupling between axial and tangential velocity components occurs, resulting in the axial adverse pressure gradient exceeds the forward kinetic forces, eventually leading to the flow being sucked back forming a central toroidal recirculation zone (CTRZ). Lucca-Negro and O'Doherty (2001) summarized that with the increase of swirl number and Reynolds number, CTRZ breaks down again. This second vortex breakdown maybe helical in nature, forming a double helix, or has a spherical body placed on the axis of vortex, sometimes it looks like a corkscrew-shaped flow.

After vortex breakdown, the flow becomes fully turbulent and unstable and starts to precess about the axis of symmetry. Syred (2006) showed this phenomenon named precessing vortex cores (PVC). PVC lies on the boundary of the reverse flow zone and corresponds closely to the area of high tangential velocity fluctuations.

Large eddy simulation (LES), as a powerful tool for solving large scale unsteady turbulent flow, has been widely accepted. This project aims at using LES as a tool to investigate structures of swirl flows. In this preliminary study, the commercial package FLUENT is used and the Sydney swirl burner non-reaction case is used as test case. In the following sections, the Sydney swirl burner and numerical details are described. The two-point correlation method is used to evaluate mesh quality. The discussion is focused on the structure of flow field.

## 2 SYDNEY SWIRL BURNER

The Sydney swirl burner is an extension of a bluff-body burner, which has both non-reaction and reaction cases, and becomes a tool for promoting research and development. The burner is sketched in Figure 1. At the burner outlet surface, there is a 50mm cylindrical face bluff-body with 3.6mm diameter nozzle, which is the exit of the central air jet ( $U_j$ ). The 5mm wide annulus is the outlet of the swirl flow ( $U_s$ ). The whole device is put into a wind tunnel which generates co-flow ( $U_e$ ). Experiments were carried out by Al-Abdeli and Masri (2003) using LDV. The present study uses non-reaction case N29S054 with geometry swirl number  $S_g (=W_s/U_s) = 0.54$  and central jet velocity  $U_j = 66\text{m/s}$ .

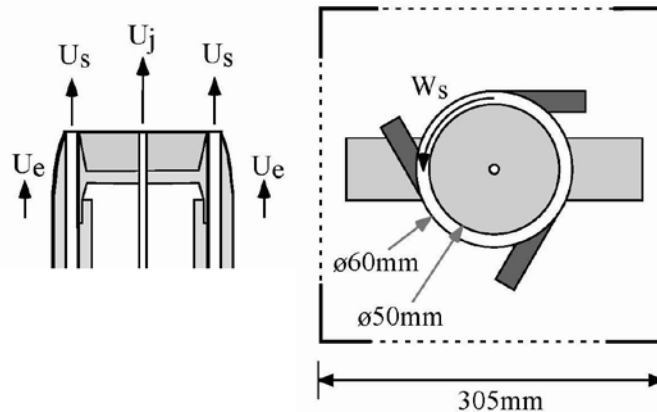

Figure 1: Structure of Sydney swirl burner

### 3 COMPUTATIONAL METHOD

Kempf and Malalasekera et al. (2008) from Imperial College London and Ranga-Dinesh et al. (2007) from Loughborough University studied the N29S054 case and reaction cases; table 1 gives main computational method of their works and the present work at AAU.

	AAU	IC	LU
Simulation domain	Cylinder D200mm, L250mm	Cylinder D440mm, L250mm	Cartesian 300mm*300mm*250mm
cells	2.23M	3.04M	1M
code	FLUENT	FLOWSI	PUFFIN
Inlet boundary	experiment velocity value	Upstream of burner exit plane	Burner exit plane
Inflow generation	Spectral synthesizer	Power law + random fluct.	Exp./DNS + turb. Generation
lateral	Free slip	Allows entrainment	Free slip
outflow	Zero gradient Neumann	Zero gradient Neumann	Convective
SGS model	Dynamic Smagorinsky-Lilly model	Dynamic Smagorinsky model	Smagorinsky eddy viscosity model with localized dynamic procedure

Table 1: computational method in this paper and previous work

## 4 RESULTS AND DISCUSSION

### 4.1 Estimating Grid Resolution

How to generate grids for LES can be guided by principle of LES; however how to evaluate resolution of LES cannot be easily decided. In this study, the two-point correlation method is used, which gives quantitative estimation of grid resolution. The initial grid is generated by calculating integral scale. Compared with Davidson's method (2009), this study focuses on the location where PVC happens. The correlation coefficient represents the degree of correlation between instantaneous pressure and velocity at two points. In the PVC vortex tube scale, a large correlation coefficient close to 1 means the two points are close and belong to the same flow structure, when it decrease to less values close to 0, the two points do not have significant connection and probably belong to different flow structures. The number of point with correlation coefficients between 1 and 0 gives an estimate of the resolution of the flow structure.

For this study, the flow zone which related to vortex breakdown and PVC needs to be well resolved. According to experimental research from Al-Abdeli and Masri (2003), the correlations are presented at axial length  $z=40\text{mm}$ , and radial position is  $r=9\sim 14\text{mm}$ .

Figure 2 shows the results. According to the figure below, in this region the correlation coefficient value increase from 0 to around 1 over 11 points, this means the largest scales are resolved by 11 cells. Based on this finding this mesh is considered sufficient for LES simulation.

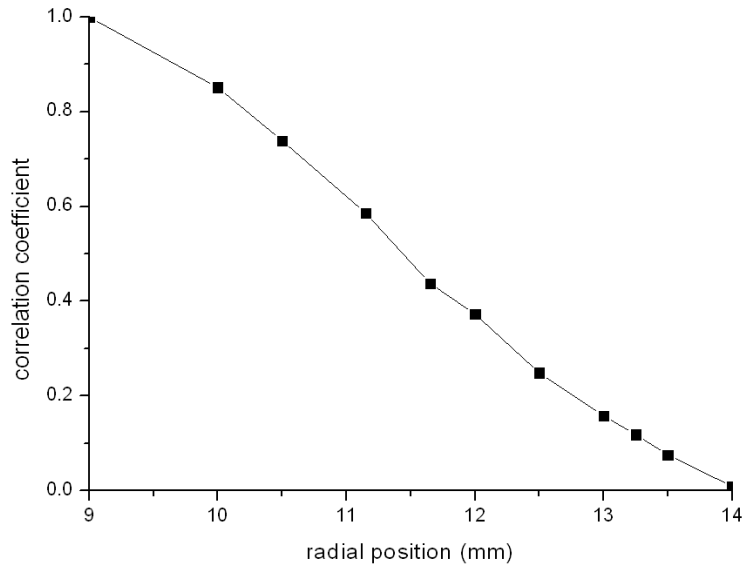

Figure 2: Two-point correlation coefficient at z=40mm, r=9~14mm

#### 4.2 Flow Field Structure

Figure 3 shows the plot of mean axial velocity at the centerline, which reveals the statistic position where vortex breakdown happens. From 0.05m to 0.09m downstream from the jet exit, the mean axial velocity is negative, which indicates bubble type recirculation zone. However, it cannot give any clue of PVC.

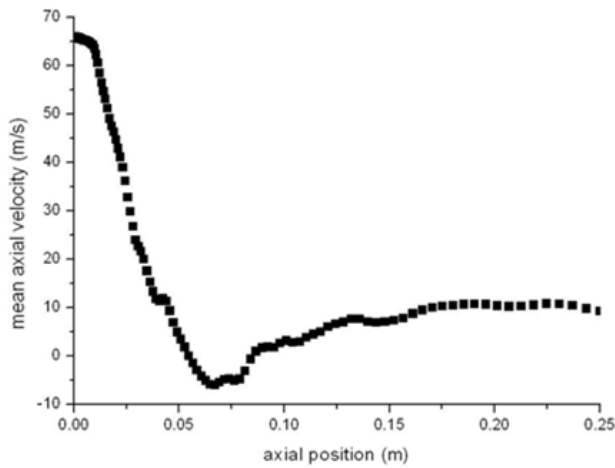

Figure 3: Mean axial velocity at centerline

Syred (2006). shows that local peak velocity fluctuations have significant relationship with PVC. By drawing the zero axial velocity line (dashed, which also shows the reverse flow zone) and localized maximum value of RMS velocity fluctuation distribution lines, their boundaries gives the flow zone of PVC.

Figure 4 shows the average axial velocity component and the RMS velocity fluctuation distributions. The value used here has been validated with experiment results and considered accordance.

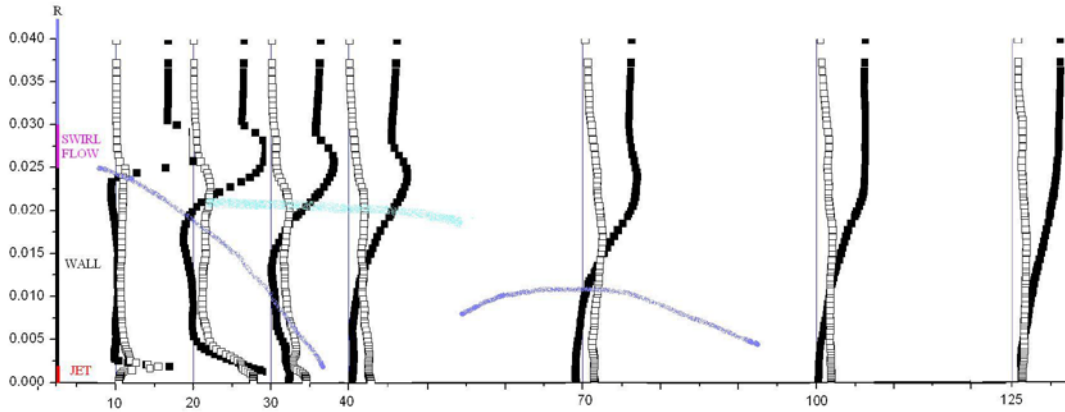

Figure 4: Radial distribution of average axial and relative RMS velocity along streamwise

Similarly, negative value of average axial velocity in different stream wise positions gives the reverse flow region. From this figure, another negative value zone can be seen. According to the preceding description, it is the second vortex breakdown.

In order to identify the small flow structure, two methods are used: (1) energy spectrum of velocity and (2) iso-surface of static pressure and contour of mean axial velocity. The former is used to distinguish different zones; and the latter is used to explain the formation of these zones.

The dominating frequencies and their relative energy distributions are expected to be different in different flow zones. Figures 5 shows the example spectrum at locations of ( $z=50\text{mm}$ ,  $r=20\text{mm}$ ).

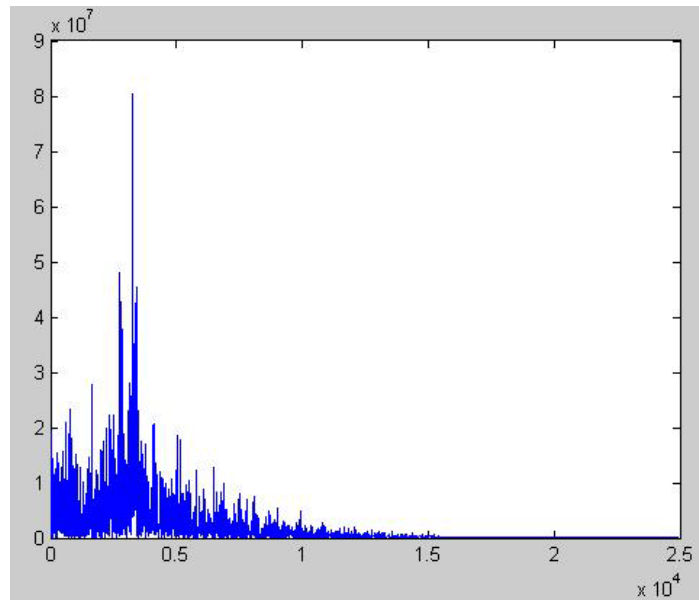

Figure 5: Spectrum at  $x=50\text{mm}$ ,  $r=20\text{mm}$

From the spectrum at different locations, the flow structure with seven different zones might be identified, as shown in Figure 6.

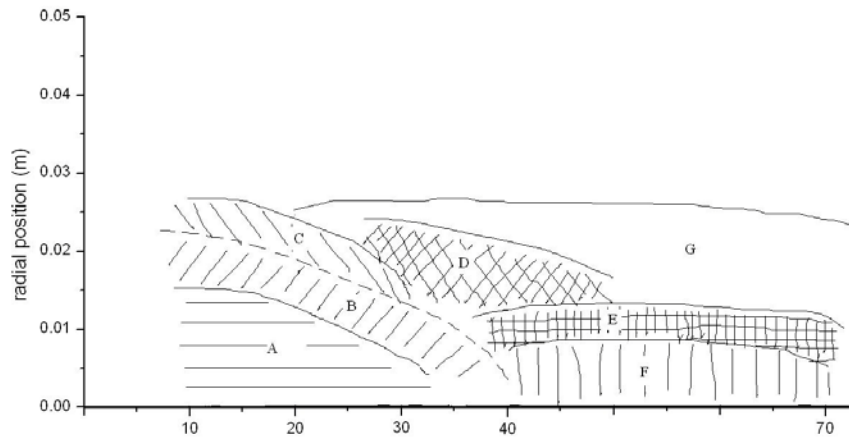
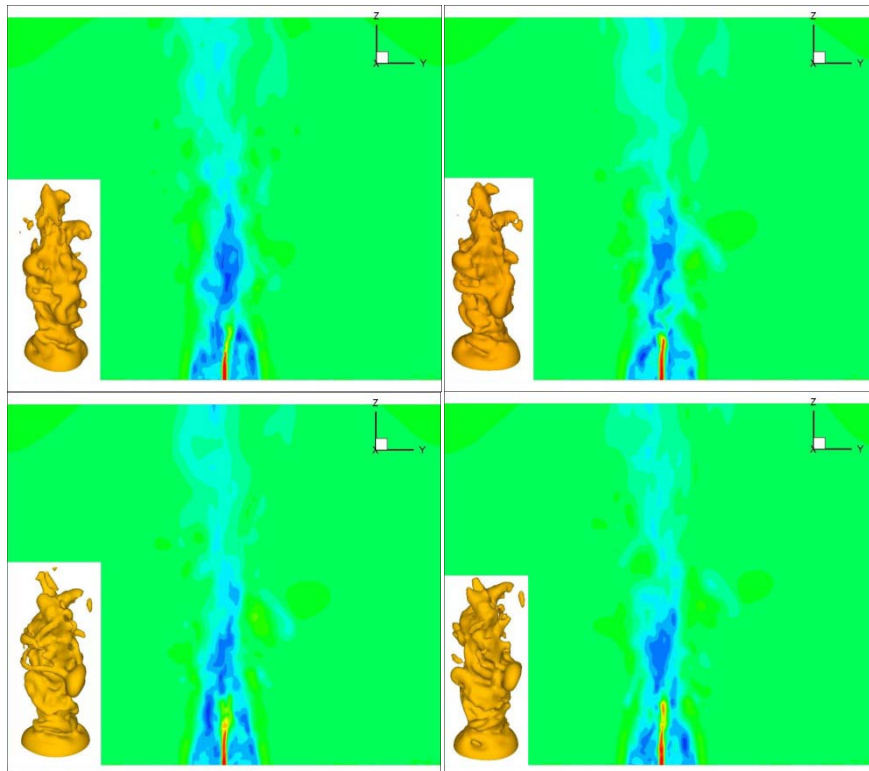

Figure 6: Sketch of the different flow zones

In order to identify the movements in the different zones, isosurface and axial velocity fields on cross-sections are introduced. By using the isosurfaces of static pressure, features can be found at relevant positions. Combined with axial velocity fields on cross-sections, we can deduce inner structure.



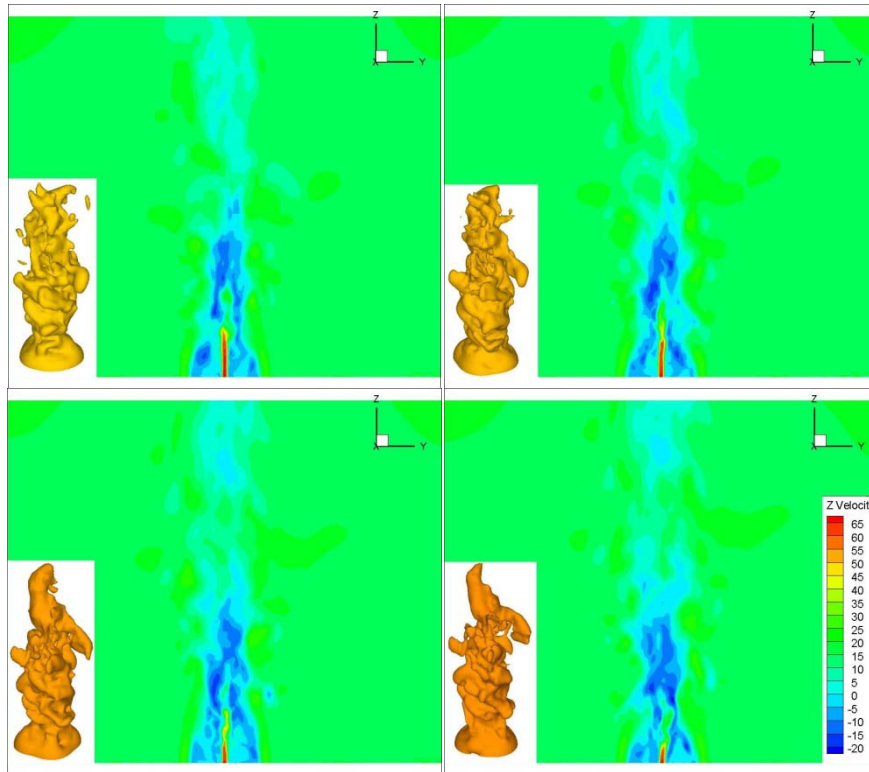

Figure 7: Isosurface of pressure and contour of axial velocity from  $t=0.171s$  to  $t=0.178s$

The axial velocity fields give the hint that there is high velocity flow group shedding along central line and there exists another reverse flow zone on central line downstream. Moreover, pressure isosurface figures indicates that the envelop wrap CTRZ zone and helix to downstream.

**Zone A:** It's expected to be the position which is dominated by the flow from central jet exit from the bluff body, which forms the reversed flow zone and central high velocity magnitude. The flow out of the jet exit first goes up, since pressure between the jet flow and the surrounding is different, then the jet flow spirals. The difference in radial direction leads to different spiral radius; hence there are many small eddies in this zone. Dominate frequency here is found to be less than 10Hz.

**Zone B:** This may correspond to the zone which has been influenced by both zone A and zone C. Shear stress is generated from the spiral jet flow and the outer ring swirl flow. This zone is found to have two dominate frequencies, around 20Hz and 85Hz.

**Zone C:** This zone is controlled by swirl flow, which entrains the flow from wind tunnel. The dominate frequency is around 160Hz.

**Zone D:** This zone can be understood as the swirl flow develops to center where the jet flow influence is dampened. Many small eddies are generated by shear stresses between them. The dominate frequency is around 160Hz, and the spectrum figure shows similar behavior as zone C.

**Zone E:** Here is the zone in which PVC may occur. According to the spectrum figure, the energy in 30Hz has a relatively high value, which could be the frequency of the PVC. The PVC starts around 40mm at axial distance. The flow follows this behavior both from the central jet and swirl jet.

**Zone F:** Flow in this region has negative axial velocity value, which implies zone F is the second reverse flow zone and second vortex breakdown zone. This VB forms bubble type.

**Zone G:** The zone is mainly influenced by the environment flow.



## 5 CONCLUSIONS

In this paper, we use large eddy simulation to study Sydney swirl flow non-reaction case N29S054. As primary study, simulation results using cube mesh and cylindrical mesh both agree with experimental data.

Two-point correlation method is used to estimate the grid resolution required. The simulation results show recirculation zones, vortex breakdown and precessing vortex core. In order to distinguish detailed structures, different monitors are set inside the flow field and the flow parameters are recorded. The spectral analysis of the monitored parameters may reveal seven different flow zones in the flow.

Further work could be focused on the reduction of noise in spectral analysis and investigation of other swirl number cases.

## ACKNOWLEDGEMENT

This research is supported by DONG Energy [PSO2007-7333].

## REFERENCES

- [1] Al-Abdeli, Y. M. and A. R. Masri (2003). "Recirculation and flowfield regimes of unconfined non-reacting swirling flows." *Experimental Thermal and Fluid Science* 27(5): 655-665
- [2] Al-Abdeli, Y. M. and A. R. Masri (2004). "Precession and recirculation in turbulent swirling isothermal jets." *Combustion Science and Technology* 176(5-6): 645-665
- [3] Davidson, L. (2009). "Large Eddy Simulations: How to evaluate resolution." *International Journal of Heat and Fluid Flow* 30(5): 25
- [4] Dinesh, K. and M. P. Kirkpatrick (2009). "Study of jet precession, recirculation and vortex breakdown in turbulent swirling jets using LES." *Computers & Fluids* 38(6): 1232-1242
- [5] Gupta A. K, D. G. Lilly, N. Syred (1984). *Swirl flows*. Kent, England, Abacus Press
- [6] Kempf, A., W. Malalasekera, et al. (2008). "Large Eddy Simulations of Swirling Non-premixed Flames With Flamelet Models: A Comparison of Numerical Methods." *Flow Turbulence and Combustion* 81(4): 523-561
- [7] Lu, X. Y., S. W. Wang, et al. (2005). "Large-eddy simulations of turbulent swirling flows injected into a dump chamber." *Journal of Fluid Mechanics* 527: 171-195
- [8] Lucca-Negro, O. and T. O'Doherty (2001). "Vortex breakdown: a review." *Progress in Energy and Combustion Science* 27(4): 431-481
- [9] Malalasekera, W., K. Dinesh, et al. (2007). "Large eddy simulation of isothermal turbulent swirling jets." *Combustion Science and Technology* 179(8): 1481-1525

[10] Stein, O. and A. Kempf (2007). "LES of the Sydney swirl flame series: A study of vortex breakdown in isothermal and reacting flows." *Proceedings of the Combustion Institute* 31: 1755-1763

[11] Syred, N. (2006). "A review of oscillation mechanisms and the role of the precessing vortex core (PVC) in swirl combustion systems." *Progress in Energy and Combustion Science* 32(2): 93-161.