



**AALBORG UNIVERSITY**  
DENMARK

**Aalborg Universitet**

## **Compressed Air Energy Storage in Denmark**

*a feasibility study and an overall energy system analysis*

Salgi, Georges Garabeth; Lund, Henrik

*Published in:*

Proceedings of the 9th World Renewable Energy Congress

*Publication date:*

2006

*Document Version*

Publisher's PDF, also known as Version of record

[Link to publication from Aalborg University](#)

*Citation for published version (APA):*

Salgi, G. G., & Lund, H. (2006). Compressed Air Energy Storage in Denmark: a feasibility study and an overall energy system analysis. In Proceedings of the 9th World Renewable Energy Congress: WREC IX, Florence, Italy, August 2006 Elsevier.

### **General rights**

Copyright and moral rights for the publications made accessible in the public portal are retained by the authors and/or other copyright owners and it is a condition of accessing publications that users recognise and abide by the legal requirements associated with these rights.

- ? Users may download and print one copy of any publication from the public portal for the purpose of private study or research.
- ? You may not further distribute the material or use it for any profit-making activity or commercial gain
- ? You may freely distribute the URL identifying the publication in the public portal ?

### **Take down policy**

If you believe that this document breaches copyright please contact us at [vbn@aub.aau.dk](mailto:vbn@aub.aau.dk) providing details, and we will remove access to the work immediately and investigate your claim.

# Compressed air energy storage in Denmark; a feasibility study and an overall energy system analysis

Georges Salgi\* and Henrik Lund

Department of Development and Planning, Aalborg University,  
Fibigerstraede 13, 9220 Aalborg, Denmark

## Abstract

Compressed air energy storage system (CAES) is a technology which can be used for integrating more fluctuating renewable energy sources into the electricity supply system. On a utility scale, CAES has a high feasibility potential compared to other storage technologies. Here, the technology is analysed with regard to the Danish energy system. In Denmark, wind power supplies 20% of the electricity demand and 50% is produced by combined heat and power (CHP). The operation of CAES requires high electricity price volatility. However, in the Nordic region, large hydro capacities have so far kept the prices from fluctuating to the extent that CAES investments have not been considered feasible. This report studies the effect of technological development and possible future price development of investments in CAES plants of various capacities. It is found that advanced high-efficiency CAES plants are likely to become feasible in the near future.

**Keywords:** Compressed air energy storage, electricity market, regulating power

---

## 1. Introduction

In 2004, wind energy provided 32% of the electricity consumption in Western Denmark. The current total installed wind turbine capacity is 2400 MW, of which 213 MW is offshore. This compares to an electricity consumption that varies between 1,150MW and 3,800MW. With high wind velocities, wind power production can exceed the local electricity demand. Moreover, the changing wind velocity gives rise to a large need of fast reserve capacity to regulate the power imbalances. The ability of the electricity system to accommodate this high level of wind energy is further complicated by the high percentage of decentralized small-scale CHP power plants with a total capacity of 1593 MW.

The system operator in Western Denmark (Energinet.dk) has so far

been able to deal with these challenges by using both local thermal resources and connections to neighbouring electricity systems. Following a new legislation, major CHP plants exceeding 5 MW are gradually operating on market conditions. As an initial result, this operation has shown an improved system balance. Such CHP plants used to operate in accordance with a triple tariff system which was not influenced by system unbalances coming from e.g. wind power [1]. However, as neighbouring countries have plans to increase their wind production in the future, this could reduce the regulating capacities available from abroad. From the perspective of socio-economy and security of supply, local reserves are preferred, especially since excess wind power is sold at low prices and bought again later at higher prices.

To solve the problem on a long term with even more wind power in the system, one will have to combine a variety of different technologies [2-6].

Electricity storage is one of the possible solutions to the challenges mentioned above. However, very few technologies tend to be economical on a utility scale. At a local level in Denmark, one of the potentially feasible technologies available nowadays is *compressed air energy storage* (CAES).

Compressed air energy storage (CAES) is a modification of the basic gas turbine (GT) technology, in which low cost electricity is used for storing compressed air in an underground cavern. This air is then heated and expanded in a gas turbine to produce electricity during peak demand hours. As it derives from GT technology, CAES technology is readily available and reliable. Two plants have been constructed in the world so far; one in Germany and one the USA of 390 MW and 110 MW turbine capacities, respectively.

Recent feasibility studies have shown that a CAES plant investment in Denmark is economically unfeasible with the current electricity prices [7]. This is mainly due to the connection with the hydro-dominated Nordic region which reduces price volatility.

However, future system analyses show an expected increase in both average electricity prices and price volatility, in particular after year 2012 in the case that no investments in new power plants are made. This increase arises from a combination of projected increase in electricity demand and a rise in CO<sub>2</sub> quota prices [8]. On the basis of these future price analyses, the feasibility of three CAES technological

scenarios is studied in this paper from a business- economic perspective.

## 2. CAES Plant Modelling

A mathematical model was developed for simulating the behaviour of a CAES plant on the electricity market. The model is divided into two parts: technical model and operational model.

### Technical Model

The technical model follows an object-oriented approach. A thermodynamic model is constructed for the main CAES plant components (compressors, inter and after coolers, throttling valves, storage cavern, combustion chambers, turbines, a regenerator, and a motor/generator unit).

A generic CAES plant design is then constructed on the basis of data from the CAES plant in Alabama [9]. The plant consists of a four-stage compression and a two-stage expansion including a regenerator (figure 1). The components are cascaded in the model where the output of one unit is used as the input to another.

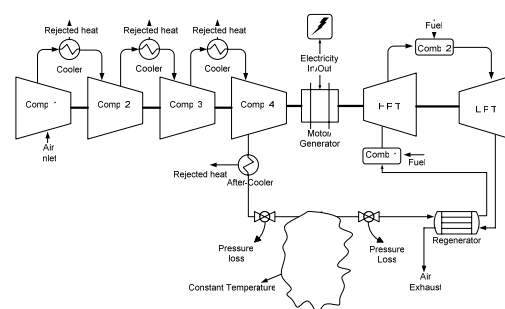

**Figure 1:** Generic CAES plant design used in the mathematical model.

The behaviour of the individual compressor and turbine units was described using isentropic efficiencies. The storage was assumed to be airtight with constant wall temperature at 35°C [10].

Three main performance indicators were used to describe the efficiency of the plant:

- The **electricity ratio (El.Ratio)**, defined as the amount of electrical power input per electricity unit output.
- The **Fuel Ratio** defined as the heat value of the utilized fuel per electricity unit output.
- The **Heat Ratio** defined as the wasted heat in the compression and expansion process per electricity unit output for a reference temperature of 30°C.

#### *Operational Model*

The operational model is concerned with optimizing the operation of the technical model on the electricity market. For this purpose, a deterministic price time series is used.

The model assumes that the plant operator develops a strategy that includes a “maximum purchase price” for air compression and a “minimum bidding price” for power generation. The optimum strategy is then found by individually varying the purchase and bidding prices in order to reach a maximum variable operational income (VOI) during the specified period. The VOI is calculated as the difference between the earnings made on the electricity market and the costs incurred by natural gas, electricity consumption, start-up costs, and operational costs.

On the basis of the time series shown in figure 2, the year is divided into four periods. The optimum purchase and bidding prices are calculated for each period and the Annual Variable Operational Income (AVOI) is found as the sum of the resulting VOI.

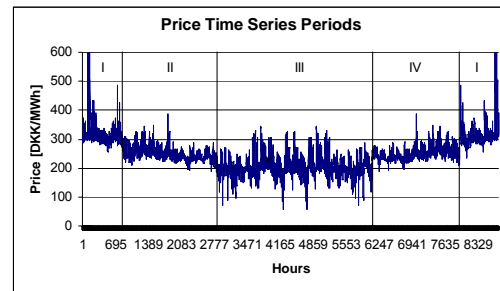

**Figure 2:** Synthetic price time series based on the 2002 system prices in Western Denmark.

Iteration is used for ensuring that the storage content is the same in the beginning and in the end of the year. Besides, a sensitivity factor is included to account for the effect of the extra consumption/ production capacity incurred by the CAES plant on the system prices.

### **3. CAES Future Scenarios**

Three main technical scenarios were used for simulating a CAES plant in Denmark. The first is the **Current Day Technology (CDT)** scenario, which is based on available data from the Alabama CAES plant [7,9].

The **State-of-the-Art Technology (SOAT)** scenario is based on the General Electric 109H system gas turbines. This advanced turbine model has a firing temperature of up to 1430°C and a combined cycle efficiency that exceeds 60% [11].

Finally, the **Advanced Technology (AT)** scenario is an attempt to reduce the fuel consumption of the SOAT by having a regenerator with 0.9% effectiveness (as compared to 0.7% in the previous scenarios) and having heat storage in which 50% of the heat rejected by the compressor can be re-used to preheat the air during expansion. Table 1 summarizes the main technical differences between the three scenarios.

**Table 1:** High and Low Pressure Turbine (HPT & LPT) firing temperature (°C), regenerator effectiveness, and compression waste heat utilization factor for the 3 technological scenarios.

	CDT	SOAT	AT
HPT Ti	538	882	882
LPT Ti	871	1428	1428
Regen. Effect.	70%	70%	90%
Waste heat use	None	None	50%

Figure 3 shows the main performance indicators of the 3 scenarios. It is seen that the SOAT represents a reduction in the electricity ratio compared to the CDT scenario. This means a lower amount of compressed air for the same turbine power output. The AT, on the other hand, represents a reduction in the fuel ratio compared to SOAT, with the electricity ratio being the same.

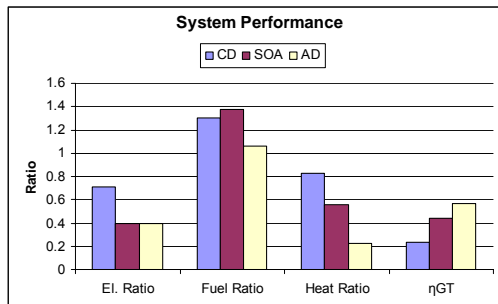

**Figure 3:** The electricity ratio, fuel ratio, heat ratio, and standard gas turbine efficiency of the three technological scenarios employed.

#### 4. Electricity Price Future Scenario

The system price development is based on a recent study done by the Risø National Laboratory (figure 4). The study assumes no major power plant investments will be made in the Nordic region apart from the plants already planned. The study also projects an increase in electricity demand and an increase in the price of the CO<sub>2</sub> quota from 6.7 Euro to 13.4 Euro in 2012.[8]

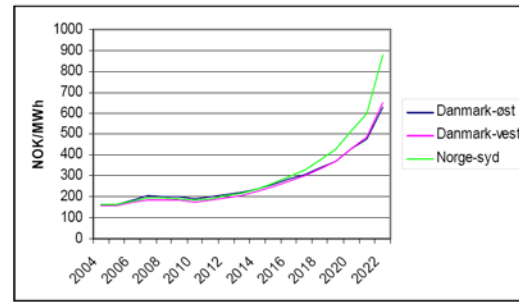

**Figure 4:** Mean annual prices in Norwegian Kroner (1NOK≈0.127Euro) as found in [8] for East and West Denmark and South Norway

#### 5. Simulation Results

The VAOI results of the three technologies at two different storage sizes are shown in Figures 5-6 for the years 2010 and 2020. Both figures show that better technology results in higher VAOI. Besides, it is seen that the VAOI increases proportionally to the turbine capacity.

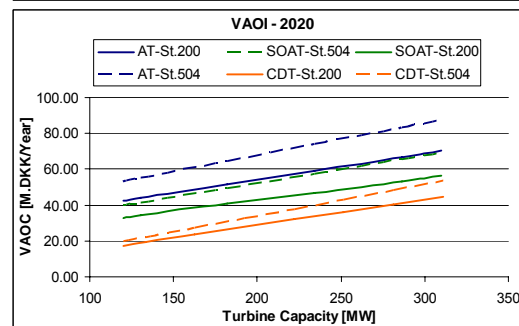
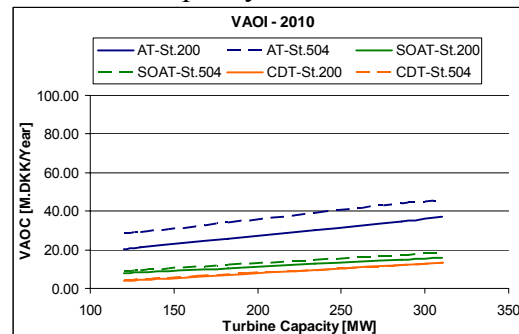

**Figures 5-6:** VAOI as a function of the turbine capacity for storage sized of 200,000m<sup>3</sup> and 504,000m<sup>3</sup> for the years 2010 and 2020.

Figure 7 shows the resulting annual turbine operational hours for the years 2010 and 2020 for the SOAT and the AT. For a small storage size of 200,000m<sup>3</sup>, the number of operational

hours is barely changed between the years 2010 and 2020 for both technologies. For the larger storage, however, the AT tends to operate a larger amount of hours in 2010.

It can be concluded that with low price fluctuation, efficiency and storage size act as limiting factors to the possible amount of operation. As prices fluctuate more, the storage size becomes the dominant factor limiting the number of operational hours.

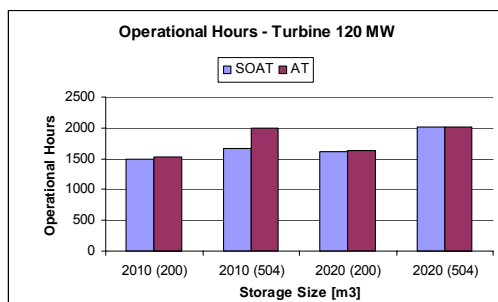

**Figure 7:** Number of turbine operational hours for a turbine capacity of 120 MW, storage sizes of 200,000m<sup>3</sup> and 504,000m<sup>3</sup>, and years 2010 and 2020.

## 6. Feasibility Study

Table 1 summarizes the main investment costs, the fixed annual costs, and the key financial parameters used [7,12]

**Table 2:** Investment costs, fixed annual costs and other financial parameters [1,6]

	AT	Unit
Cavern [1]	321	DKK/m3
Comp.+ Intercooler	0.81	MDKK/MW
Turb + Burner + Regenerator	1.35	MDKK/MW
Motor/Generator	0.54	MDKK/MW
Land/Build/ Transactions	20	MDKK
Heat Storage	1700	DKK/m3
Fixed O&M [50 - 150MW]	75,000	DKK/MW/Yr
Fixed O&M [150 - 250MW]	45,000	DKK/MW/Yr

Fixed Cost [>250MW]	30,000	DKK/MW/Yr
Lifetime	30	Yrs
Interest Rate	4.00%	%

The investment costs are annualized using the Net Present Value relation and then subtracted from the VOAI. The results for the SOAT and the AT are shown in Figures 8-9. The results for the CDT are not shown since the investment is not feasible over all the years. It is noted, however, that the curves for the CDT display a similar trend to the one shown in Figures 10-11. The figures show, on the other hand, that the SOAT can become feasible around year 2018, whereas the AT may be feasible as early as in 2012.

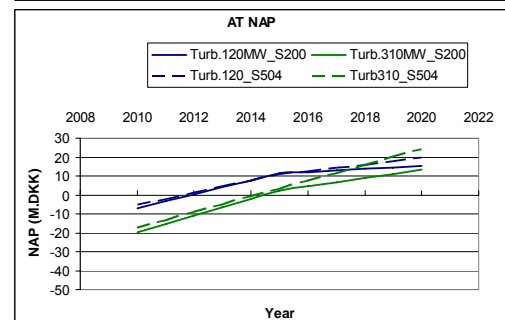
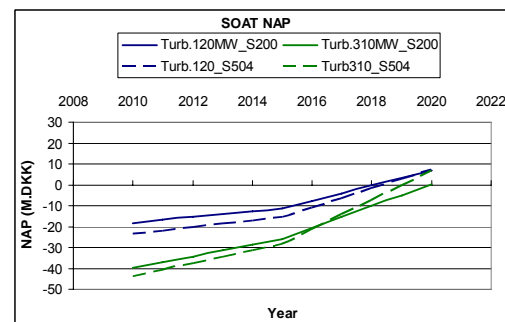

**Figures 8-9:** Net Annual Profit (NAP) for the SOAT and AT for two values of storage size (200,000 m<sup>3</sup> and 504,000 m<sup>3</sup>) and two turbine sizes (120 MW and 310 MW).

Figures 8-9 show that, during the initial years with low price volatility, a smaller turbine capacity benefits from the lower investment cost which gives a higher feasibility than the 310 MW. As the fluctuation increases, larger turbine sizes start gaining significance and tend to exceed the profit from the small turbine. This is because 310 MW

turbines are able to benefit better from sharp price peaks than 120 MW turbines.

## 7. Conclusion

A feasibility study of various technical and future price scenarios was performed. For this purpose, a technical model was developed that could simulate the behaviour of a CAES plant. This model is used within an operational model that optimizes the CAES plant operation.

It is found that an improved CAES plant performance improves the feasibility of such a plant considerably. Advanced technology plants can be feasible as early as 2012. The recommended turbine capacity depends on the expected price average and fluctuation as well as the plant efficiency. At low price volatility, low turbine capacities are more feasible, whereas at higher price volatility, larger turbine capacities are more feasible. Concerning the storage size, larger storage sizes are favourable for advanced technology in all years and for state-of-the-art technology in years with high price volatility. For the current technology, the cavern size has little impact on the number of operational hours.

## References

- [1] Lund, H and Andersen, A N. Optimal designs of small CHP plants in a market with fluctuating electricity prices. *Energy Conversion and Management* 2005;46(6):893-904.
- [2] Lund, H. Excess Electricity Diagrams and the Integration of Renewable Energy. *International Journal of Sustainable Energy* 2003;23(4):149-156.
- [3] Lund, H and Münster, E. Modelling of energy systems with a high percentage of CHP and wind power. *Renewable Energy* 2003;28(14):2179-2193.
- [4] Lund, H. Large-scale integration of optimal combinations of PV, wind and wave power into the electricity supply. *Renewable Energy* 2006;31(4):503-515.
- [5] Lund, H and Munster, E. Integrated energy systems and local energy markets. *Energy Policy* In Press, Corrected Proof
- [6] Lund, H. Large-scale integration of wind power into different energy systems. *Energy* 2005;30(13):2402-2412.
- [7] Brix W., Szameitat N., CAES – Muligheder I Danmark, Danish Technical University, Institute of mechanics, energy and construction., spring 2003
- [8] Morthorst P.E., Jensen G.S., Meibom P., Investering og prisdannelse på et liberaliseret elmarked, Risø Research Center, Roskilde, Denmark, May 2005.
- [9] Boyce M.P., Handbook for Cogeneration and Combined Cycle Power Plants, ASME Press, New York, 2002
- [10] Crotogino F., Mohmeyer K.U., Scharf R., Huntorf CAES: More than 20 years of Successful Operation, KBB GmbH and E.ON Kraftwerke Bremen, Spring 2001 Meeting, Orlando, Florida, USA, 15-18 April, 2001
- [11] Matta R.K., Mercer C.D., Tuthill R.S., Power Systems for the 21st Century – “H” Gas Turbine Combined Cycles, GE Power Systems, Schenectady NY, 2004.
- [12] Energistyrelsen, Eltra, and Elkraft, Technology Data for Electricity and Heat Generating Plants, March 2005