



**AALBORG UNIVERSITY**  
DENMARK

**Aalborg Universitet**

## **LTR Design of Proportional-Integral Observers**

Niemann, H.H.; Stoustrup, Jakob; Shafai, B.; Beale, S.

*Published in:*  
International Journal of Robust and Nonlinear Control

*DOI (link to publication from Publisher):*  
[10.1002/rnc.4590050706](https://doi.org/10.1002/rnc.4590050706)

*Publication date:*  
1995

*Document Version*  
Tidlig version også kaldet pre-print

[Link to publication from Aalborg University](#)

*Citation for published version (APA):*  
Niemann, H. H., Stoustrup, J., Shafai, B., & Beale, S. (1995). LTR Design of Proportional-Integral Observers. *International Journal of Robust and Nonlinear Control*, 671-693. <https://doi.org/10.1002/rnc.4590050706>

### **General rights**

Copyright and moral rights for the publications made accessible in the public portal are retained by the authors and/or other copyright owners and it is a condition of accessing publications that users recognise and abide by the legal requirements associated with these rights.

- Users may download and print one copy of any publication from the public portal for the purpose of private study or research.
- You may not further distribute the material or use it for any profit-making activity or commercial gain
- You may freely distribute the URL identifying the publication in the public portal -

### **Take down policy**

If you believe that this document breaches copyright please contact us at [vbn@aub.aau.dk](mailto:vbn@aub.aau.dk) providing details, and we will remove access to the work immediately and investigate your claim.

## LTR DESIGN OF PROPORTIONAL-INTEGRAL OBSERVERS

H. H. NIEMANN

*Institute of Automation Systems, Building 326, Technical University of Denmark, DK-2800, Lyngby, Denmark*

J. STOUSTRUP

*Mathematical Institute, Technical University of Denmark, Building 303, DK-2800, Lyngby, Denmark*

AND

B. SHAFAI AND S. BEALE

*Department of Electrical and Computer Engineering, Northeastern University, 360 Huntington Avenue, Boston, MA 02115, U.S.A.*

### SUMMARY

This paper applies the proportional-integral (PI) observer in connection with loop transfer recovery (LTR) design for continuous-time systems. We show that a PI observer makes it possible to obtain time recovery, i.e., exact recovery for  $t \rightarrow \infty$ , under mild conditions. Based on an extension of the LQG/LTR method of proportional (P) observers, a systematic LTR design method is derived for the PI observer. Our recovery design method allows time recovery and frequency (normal) recovery to be done independently. Furthermore, we give explicit expressions for the recovery error when asymptotic recovery cannot be obtained. A design example demonstrates the advantages of time recovery in the non-minimum phase case.

**KEY WORDS** loop transfer recovery; proportional–integral observer; non–minimum phase systems

### 1. INTRODUCTION

Since the appearance of the papers by Doyle and Stein<sup>5,6</sup> dealing with loop transfer recovery (LTR), many papers have been written on this topic for both continuous- and discrete-time systems. The reason for the current research effort is that one is required to (a) provide LTR design with low gain, (b) consider the trade-off between the level of LTR and the necessary gain, which in turn relates to fundamental trade-offs in control system design, (c) handle non-minimum phase systems, (d) achieve recovery at both the plant input and output, and (e) provide a parallel treatment for discrete-time systems. Recent works, including Lee and Chen,<sup>8</sup> Okada *et al.*,<sup>16,17</sup> Niemann *et al.*,<sup>14,15</sup> Shafai *et al.*<sup>20</sup> and Saeki<sup>19</sup> concentrated on these issues; and both observer-based controllers and general compensator structures were proposed. The applied observer types have been, in most cases, full-order or minimal-order observers, but more general observer architectures have also been used in LTR design.

Beale and Shafai<sup>3</sup> introduced the proportional-integral (PI) observer in LTR design. A PI observer is an observer with an integrating effect which takes care of the asymptotic time behaviour. The

results derived in Reference 3 are based on an extension of the LTR results for full-order observers given in References 5 and 6; however, Niemann *et al.*<sup>14</sup> later presented more general forms.

The main benefit of the PI observer is the time recovery effect. Under mild conditions the PI observer results in exact loop transfer recovery (ELTR) as time tends to infinity, termed as time recovery. Another advantage over the usual full-order, proportional (P) observer is the need for relatively low observer gains. This benefit makes the PI observer useful from a practical standpoint since bounded controller gains are often a design condition which limits the LTR design. In general, a PI observer allows good recovery at low frequencies even without employing specific LTR design methods, whereas the usual full or reduced-order P observer allows good recovery at low frequencies only in the limit. Unfortunately, the formulation given in Reference 3 cannot be used systematically as in LQG, pole placement, etc. due to too many free parameters. To overcome this problem a new formulation of the PI observer was given in Reference 12. This new formulation allows one to use systematic design methods.

An alternative way to obtain good recovery at low frequencies, is to augment integrators to the plant before the target design is performed.<sup>29,2</sup> By doing this, the target design is changed in such a way that it is easy to recover the target loop at low frequencies. However, this implies that in this approach, the target loop is no longer entirely free, because an integral effect needs to be included in the target loop. In contrast, when the PI-observer approach is used, the integral effect is included in the observer. Therefore, the target design is completely free.

In this paper we use this new formulation of the continuous-time PI observer to derive systematic LQG and LQG/LTR design methods for PI observers.

## 2. CONTINUOUS-TIME PI OBSERVER

### 2.1. Full-order PI observer

Consider a finite-dimensional, linear, time-invariant system  $\Sigma$  described by a stabilizing and detectable state-space realization  $(A, B, C)$ :

$$\Sigma: \begin{cases} \dot{x} = Ax + Bu \\ y = Cx \end{cases} \quad (1)$$

where  $x \in \mathbb{R}^n$ ,  $u \in \mathbb{R}^r$ , and  $y \in \mathbb{R}^m$  with  $m \geq r$ ,  $n > m$ ,  $(A, B)$  stabilizable,  $(C, A)$  detectable,  $C$  and  $B$  has full rank.

Let the plant be controlled by an observer-based controller having the state feedback

$$u = F\hat{x} + r = w + r \quad (2)$$

where  $F$  is the state feedback gain and  $\hat{x}$ , the state estimate.  $F$  is required to be stabilizing, i.e.  $A + BF$  having eigenvalues in the left half plane and otherwise free. The states are estimated by a proportional-integral (PI) observer:<sup>3,14</sup>

$$\Sigma_{\text{O}}: \begin{cases} \dot{\hat{x}} = A\hat{x} + K(C\hat{x} - y) + Bu + Hv \\ \dot{v} = C\hat{x} - y \end{cases} \quad (3)$$

where  $v \in \mathbb{R}^m$ ,  $K$  is the P observer gain and  $H$ , the I observer gain. The PI observer is required to be internally stabilizing, which is satisfied if and only if all the eigenvalues of the matrix

$$R = \begin{bmatrix} A + KC & H \\ C & 0 \end{bmatrix} \quad (4)$$

have negative real parts.

Note that the two gains  $K$  and  $H$  cannot be designed independently, which complicates the observer design. Furthermore, there are  $2(n \times m)$  parameters to be selected for placing the  $n + m$  closed-loop poles. There does not exist any direct method at this time for the design of  $K$  and  $H$  in (3).

Instead of using the PI observer described above, we modify it and use this modified version to derive systematic design methods. The dual version of the PI state feedback<sup>1</sup> gives the following PI observer, as shown in Figure 2:

$$\Sigma_{PI} : \begin{cases} \dot{\hat{x}} = A\hat{x} + K_p(C\hat{x} - y) + Bu + Bv \\ \dot{v} = K_I(C\hat{x} - y) \end{cases} \quad (5)$$

where  $K_I \in \mathbb{R}^{m \times m}$ . Note that when  $K_I = 0$ ,  $K_p = K$  we have a conventional P observer as shown in Figure 1. The stability condition requires that the eigenvalues of  $R$ , given by

$$R = \begin{bmatrix} A + K_p C & B \\ K_I C & 0 \end{bmatrix} \quad (6)$$

have negative real parts.

In this configuration, the number of design parameters for placing the  $n + m$  observer poles reduces to  $(n + m) \times m$ . Moreover, it is now possible to derive systematic design methods by considering the closed-loop system as an extended state system. The PI observer-based controller can be represented by

$$\Sigma_{PIC} : \begin{cases} \dot{z} = A_x z + K_x(C_x z - y) + B_x u \\ u = F_x z \end{cases} \quad (7)$$

where

$$A_x = \begin{bmatrix} A & B \\ 0 & 0 \end{bmatrix}, \quad B_x = \begin{bmatrix} B \\ 0 \end{bmatrix}, \quad C_x = [C \ 0], \quad K_x = \begin{bmatrix} K_p \\ K_I \end{bmatrix} \quad (8)$$

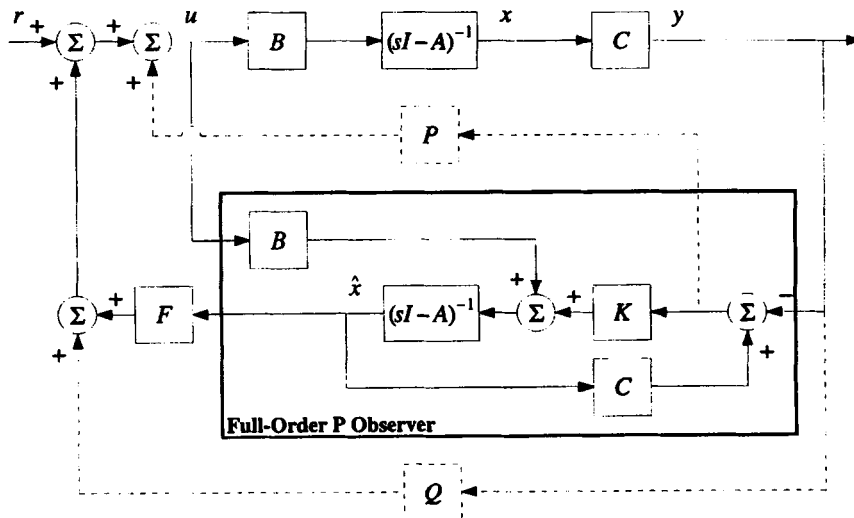

Figure 1

and

$$F_x = [F \ 0] \tag{9}$$

Methods such as LQG, eigenstructure assignment, etc. can now be applied as in ordinary observer design to determine the gain  $K_x$ .<sup>25,23,18</sup>

2.2. Reduced-order PI observer

The difficulty encountered in the past for the design of a reduced-order PI observer can be overcome by considering  $\Sigma_{PI}$  as applied to the subsystem of  $\Sigma$ . Without loss of generality, let us assume that

$$C = [I_m \ 0] \tag{10}$$

and, hence, the system described by (1) is in the form

$$\Sigma: \begin{cases} \dot{x}_2 = A_{22}x_2 + \tilde{B}\tilde{u} \\ \tilde{y} = A_{12}x_2 \end{cases} \tag{11}$$

where  $\tilde{y} = \dot{y} - A_{11}y - B_1u$ ,  $\tilde{u} = [y^T \ u^T]^T$ , and  $\tilde{B} = [A_{21} \ B_2]$ . Furthermore, let the state feedback gain  $F$  be partitioned consistently as

$$F = [F_1 \ F_2] \tag{12}$$

Recall<sup>9</sup> that for a reduced-order P observer of the form

$$\Sigma_{RP}: \begin{cases} \dot{z} = Dz + Gy + Hu \\ \hat{x} = Mz + Ny \end{cases} \tag{13}$$

we have the following constraints:

$$\text{Re}[\lambda(D)] < 0 \tag{14}$$

$$TA - DT = GC \tag{15}$$

$$H = TB \tag{16}$$

$$MT + NC = I \tag{17}$$

where the  $(n - m) \times n$  matrix  $T$  relates the observer and the system through  $z = Tx + e$ , which in turn is related to the state reconstruction error by  $\tilde{x} = \hat{x} - x = M(z - Tx)$ . Figure 2 shows the conventional reduced-order P observer.

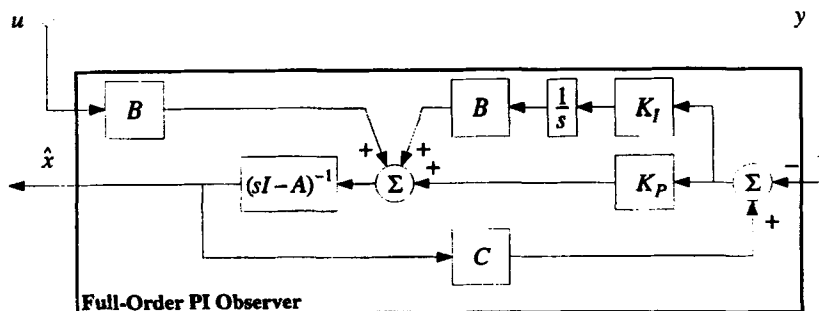

Figure 2

Under the above partitioning for  $\Sigma$ , the matrix  $T$  is of the form  $T = [-L \ I]$ , and the observer matrices  $D$ ,  $G$  and  $H$  are given respectively by

$$D = A_{22} + LA_{12} \quad (18)$$

$$G = A_{21} + LA_{11} - LA_{12}L - A_{22}L \quad (19)$$

$$H = B_2 + LB_1 \quad (20)$$

Note that the estimated states are specified by  $\hat{x}_1 = x_1 = y$  and  $\hat{x}_2 = z - Ly$ .

Now we are ready to define the following reduced-order PI observer:<sup>14</sup>

$$\Sigma_{\text{RPI}}: \begin{cases} \dot{\hat{x}}_2 = A_{22}\hat{x}_2 + L_P(A_{12}\hat{x}_2 - \bar{y}) + \bar{B}\bar{u} + \bar{B}w \\ \dot{w} = L_1(A_{12}\hat{x}_2 - \bar{y}) \end{cases} \quad (21)$$

An extended state form of (21) is given by

$$\Sigma_{\text{RPI}}: \dot{z} = A_E z + L_E(C_E z - \bar{y}) + B_E \bar{u} \quad (22)$$

where  $z = [\hat{x}_2^T \ w^T]^T$  and

$$A_E = \begin{bmatrix} A_{22} & \bar{B} \\ 0 & 0 \end{bmatrix}, \quad B_E = \begin{bmatrix} \bar{B} \\ 0 \end{bmatrix}, \quad C_E = [A_{12} \ 0], \quad L_E = \begin{bmatrix} L_P \\ L_1 \end{bmatrix} \quad (23)$$

To avoid the need for differentiators, due to the presents of  $\dot{y}$  in  $\bar{y}$ , we rewrite (22) with respect to a new variable,  $z_E = z - L_E y$ , as follows:

$$\Sigma_{\text{RPI}}: \begin{cases} \dot{z}_E = D_E z_E + G_E y + H_E u \\ \dot{\hat{x}}_E = M_E z_E + N_E y \end{cases} \quad (24)$$

where  $\hat{x}_E = [\hat{x}_2^T \ w^T]^T$  is an extended state estimate. The matrices  $D_E$ ,  $G_E$ , and  $H_E$  are given respectively by

$$D_E = A_E + L_E C_E \quad (25)$$

$$G_E = R_E + L_E A_{11} - L_E C_E L_E - A_E L_E \quad (26)$$

$$H_E = S_E + L_E B_1 \quad (27)$$

where

$$R_E = \begin{bmatrix} A_{21} \\ 0 \end{bmatrix}, \quad S_E = \begin{bmatrix} B_2 \\ 0 \end{bmatrix} \quad (28)$$

and

$$M_E = \begin{bmatrix} 0 \\ I_{n+r} \end{bmatrix}, \quad N_E = \begin{bmatrix} I_m \\ -L_E \end{bmatrix} \quad (29)$$

The reduced-order observer given by (24) includes, inherently, the integral term and has the same configuration as depicted in Figure 2 with the parameters  $\{D_E, G_E, H_E, M_E, N_E\}$  replaced by  $\{D, G, H, M, N\}$ .

Using the form of  $\Sigma_{\text{RPI}}$  given in (24), we can now apply systematic design methods as in conventional reduced-order observer design<sup>22</sup> to determine the gain  $L_E$ . Since our main interest is LTR design of P and PI observers, we shall consider this in the next section.

### 3. LTR WITH P AND PI OBSERVERS

To design a controller for the system  $\Sigma$  by the LTR design methodology, we first determine a static state feedback, the target design, which satisfies our design specifications. The design specifications, such as robust stability and nominal performance conditions, are assumed to be reflected at the plant input point.<sup>25</sup>

Based on the target (full-state feedback) design gain  $F$  for the system  $\Sigma$ , the target sensitivity function is given by

$$S_{\text{TFL}}(s) = (I - L_{\text{TFL}}(s))^{-1} \quad (30)$$

where  $L_{\text{TFL}}(s) = F(sI - A)^{-1}B$  represents the target (full-state feedback) loop transfer function. Next the LTR step is performed in which we attempt to recover the target design over a range of frequencies by a dynamic compensator  $C(s)$ . This step gives a full-loop, sensitivity transfer function of the form

$$S_1(s) = (I - C(s)G(s))^{-1} \quad (31)$$

where  $G(s)$  represents the plant transfer function.

Assuming that  $C(s)$  is implemented via an observer (or Kalman filter) based controller, the resulting loop transfer function  $C(s)G(s)$ , in general, is not the same as the target loop transfer function  $L_{\text{TFL}}(s)$ . In the LTR step the required observer is designed so as to recover either exactly (perfectly) or asymptotically (approximately) the target loop transfer function.

For a more careful analysis, we define the sensitivity loop transfer recovery error as

$$E_S(s) = S_{\text{TFL}}(s) - S_1(s) \quad (32)$$

and say that exact loop transfer recovery at the input point (ELTRI) is achieved if the closed-loop system comprised of  $C(s)$  and  $G(s)$  is asymptotically stable and  $E_S(s) = 0$ . To define approximate or asymptotic LTR at the input point (ALTRI), see References 6 and 25, we parametrize the family of controllers as  $C(s, q)$ , where  $q$  is a positive scalar, and say that ALTRI is achieved if the closed-loop system is asymptotically stable and  $S_1(s) \rightarrow S_{\text{TFL}}(s)$  pointwise in  $s$  as  $q \rightarrow \infty$ , i.e.,  $E_S(s, q) \rightarrow 0$  pointwise in  $s$  as  $q \rightarrow \infty$ .

The sensitivity recovery error is related to the so-called recovery matrix  $M_1(s)$  given in Reference 14 by the equation

$$E_S(s) = S_{\text{TFL}}(s)M_1(s)$$

With this background we are ready to discuss the LTR of full-order observers.

#### 3.1. ELTRI and ALTRI with full-order P and PI observers

*3.1.1. Overview.* Consider the full-order P observer-based controller having the transfer function

$$C(s) = F(sI - (A + KC) - BF)^{-1}K \quad (33)$$

where  $F$  and  $K$  are the regulator and observer gains, respectively. Then ELTRI is achieved if and only if  $E_S(s) = 0$  or equivalently  $M_1(s) = 0$  where

$$M_1(s) = F(sI - A - KC)^{-1}B \quad (34)$$

In practice, the condition  $M_1(s) = 0$  cannot always be satisfied exactly. Consequently, the size of  $M_1(s)$  should be made small in some sense.

Let the controller be parametrized in terms of the observer gain by  $K(q)$ . Then to obtain ALTRI we seek a  $K(q)$  such that for all  $\omega$

$$M_1(j\omega) = F(j\omega I - A - K(q)C)^{-1}B \rightarrow 0 \quad \text{as } q \rightarrow \infty \quad (35)$$

The literature reports several methods<sup>5,2,25,23,18</sup> of obtaining such a  $K(q)$ . Usually, exact recovery is not possible. Hence, good recovery can be achieved only in the limit as  $q \rightarrow \infty$  which implies that  $\|K(q)\| \rightarrow \infty$ .

Increasing the gain  $K(q)$  is related to the level of recovery and requires minimization of  $\sigma_{\max}[M_1(j\omega)]$ . This trade-off can be visualized in terms of the trade-off between the singular values of the sensitivity and complementary sensitivity functions, reflecting the trade-off between robust stability and performance, and the level of recovery which is related to the singular values of  $M_1(j\omega)$ . Søgaard-Andersen and Niemann<sup>24</sup> derived analytical expressions and bounds which relate these singular values. More recently Stoustrup and Niemann<sup>27,28</sup> introduced LTR design methods which use  $H_\infty$  control theory. These results enable one to examine the limit of recovery for both minimum and non-minimum phase systems. Consequently, Saeki<sup>19</sup> and Niemann *et al.*<sup>15</sup> developed  $H_\infty$ /LTR procedures with a specified degree of recovery.

Other approaches consider observer-based controllers having structural changes so that either ELTR or ALTR is achieved without large filter or regulator gains. Consider the closed-loop system comprising a plant and full-order P observer-based controller as shown in Figure 1. Both closed-loop asymptotic stability and ELTRI can be achieved under the assumptions that (1)  $FB = 0$ , (2) the plant has all of its infinite zeros of order one (i.e.,  $CB$  has full rank), and (3) the plant is left invertible and has all its invariant zeros in the left half  $s$ -plane (i.e., the plant is minimum phase).

Since  $FB = 0$  severely restricts the design of ELTRI systems, most researchers have focused attention on ALTRI methods. Here one tries to find a gain  $K$  which satisfies (35) as we discussed earlier. If the plant is left invertible and minimum phase, it can be shown that there exists such a gain which both achieves ALTRI and guarantees asymptotic stability.

The loss of robustness in observer-based systems is due to the path from the control signal  $u$  to the observer via the control input matrix  $B$  as depicted in Figures 1 and 2. Based on this observation Saberi *et al.*,<sup>18</sup> removed the aforementioned path at the outset of controller design. This technique leads to a new compensator design philosophy which is outside the realm of observer theory and, hence, the separation principle. Consequently, one must prove that closed-loop stability and LTR are simultaneously achieved. For a plant which is neither minimum phase nor left-invertible, Saberi *et al.*,<sup>18</sup> established necessary and sufficient conditions for the existence of a recoverable target loop for observer-based and general compensator structures, respectively. They have shown that the set of recoverable target loops is nonempty if and only if an auxiliary system constructed from the plant is stabilizable by a static output feedback. This leads to a surprising result which states that the strong stabilizability of the plant is a necessary condition for the plant to have at least one recoverable target loop.

Within the framework of observer theory, attempts have been made to define alternative structures. An interesting approach which achieves ELTR, under the assumptions (2) and (3) above, is reported in Reference 16 whereby an output feedback path having a gain  $Q$ , shown by the broken line of Figure 1, is added to the configuration. The resulting characteristic equation of the closed-loop system is given by the product of  $\det(sI - A - KC)$ , which is from the observer or Kalman filter and thus stable, and  $\det(sI - A - BF + BQC)$ . The latter polynomial remains stable despite how large  $Q$  becomes, provided that (1)  $CB$  has rank  $m$  ( $m \leq r$ ) and (2)  $\Lambda(s)$  has rank  $n + m$  for all  $s$  where

$$\Lambda(s) = \begin{bmatrix} sI - A - BF & B \\ C & 0 \end{bmatrix} \quad (36)$$



Okada *et al.*<sup>17</sup> proposed an optimization technique to determine a  $Q$  so that stability and performance robustness requirements are satisfied while ALTRI or ELTRI is realized. It has been shown that with P<sup>16</sup> and PI<sup>4</sup> observers, ELTRI can be achieved by including this output feedback path with the usual assumptions on the plant as stated above. Section 3.2 explores the rationale behind this achievement of ELTRI in connection to the LTR design of reduced-order observers.

A precompensator may be used in an ELTRI system to improve the response properties with respect to parameter perturbations and disturbances. The precompensator makes behaviour of the perturbed closed-loop system between  $r$  and  $y$  similar to that of the optimal, full-state regulator. For arbitrary response characteristics one can use a prefilter or extended perfect model following the methods of References 16 and 17. The drawback of these precompensation methods is the increase in controller dimension.

To overcome this increase in controller dimension, one may add an output estimating error feedback loop with gain  $P$  as shown by the broken line of Figure 1. Since this loop does not change the closed-loop response characteristic, the resulting system does not require a precompensator and is, therefore, termed as an implicit model matching system. The possibility of achieving recovery at both the plant input and output makes this method advantageous; however, it is generally difficult to realize this goal with a fixed gain  $P$ , and one is required to use a dynamic gain matrix. Shafai *et al.*<sup>21</sup> analysed P and PI observer-based controllers, as shown in Figures 1 and 2, with both  $P$  and  $Q$  considered as general dynamic structures.

Our discussion so far has concentrated on full-order observer-based controllers with the target loop specified at the plant input point. Similar arguments pertain to the case where the target loop is specified at the plant output point. In this case we try to achieve ELTRO or ALTRO; however, we shall not elaborate on these topics.

**3.1.2 ELTRI AND ALTRI with PI observers.** For the PI observer-based controller as described in Section 2.1, we obtain the following result.

*Lemma 3.1*

Consider the system (1) with the controller (7). We get

$$E_S(s) = S_{\text{TFL}}(s)M_1(s) \quad (37)$$

where the recovery matrix  $M_1$  is given by

$$M_1(s) = F_x(sI - A_x - K_x C_x)^{-1} B_x \quad (38)$$

$$= sF(s^2 I - s(A + K_p C) - BK_1 C)^{-1} B \quad (39)$$

*Proof.* The proof can be found in Reference 14. □

As shown above the matrix  $M_1(s)$  introduced here is strongly related to the recovery error. In Reference 14 it has been shown that  $M_1(s)$  is the open-loop transfer function between the control input signal and the control output signal of the observer. Henceforth we shall call  $M_1(s)$  the recovery matrix.

Using Lemma 3.1 we give the following necessary and sufficient conditions on  $M_1(s)$  for exact or asymptotic recovery.

*Lemma 3.2*

Let the sensitivity recovery error be given by (32). ELTRI is obtained if and only if one of the following equivalent conditions holds:

$$E_S(s) = 0 \quad (40)$$

$$M_1(s) = 0 \quad (41)$$

ALTRI is obtained if and only if for all  $\varepsilon > 0$  there exists a controller  $C_\varepsilon$  such that

$$\|E_{S,\varepsilon}(\cdot)\|_H < \varepsilon \quad (42)$$

or equivalently

$$\|M_{E,\varepsilon}(\cdot)\|_H < \varepsilon \quad (43)$$

where  $E_{S,\varepsilon}(s)$  and  $M_{1,\varepsilon}(s)$  correspond to  $C_\varepsilon(s)$  and where  $\|\cdot\|_H$  is the  $\mathcal{H}_2$  or the  $\mathcal{H}_\infty$ , norm.

*Proof.* See Reference 14. □

In some cases the step response of the recovery error  $E_S$  tends to zero as  $t \rightarrow \infty$  which happens exactly when  $\lim_{s \rightarrow 0} E_S(s) = 0$ .

Motivated by (37) let us define *time recovery* in the following way.

*Definition 3.1*

Let  $M_1(s)$  be the recovery matrix. Time recovery is obtained if and only if

$$M_1(0) = 0 \quad (44)$$

Time recovery means that we obtain exact recovery in the steady state ( $t \rightarrow \infty$ ). Traditional LTR design normally yields a steady-state recovery error; see the example in Reference 27. It is, in general, difficult to obtain time recovery with an arbitrary observer type. As pointed out above, however, the PI observer architecture facilitates time recovery under mild conditions. These conditions are given in the following theorem.

*Theorem 3.1*

Time recovery is obtained if and only if the largest invariant subspace of the matrix  $A_K^{-1}BK_1C$ , where  $A_K = A + K_pC$ , contained in the controllable subspace of the pair  $(A_K^{-1}BK_1C, A_K^{-1}B)$  corresponding to the eigenvalue  $s = 0$  is itself contained in the unobservable subspace of the pair  $(F, A_K^{-1}BK_1C)$ .

*Proof.* See Appendix A. □

From the constructive proof, we can easily find verifiable matrix conditions corresponding to Theorem 3.1. The corollary below follows from the observation that the only trajectory which tends to zero as  $t \rightarrow \infty$  for a system in which all of its eigenvalues are zero is the zero trajectory. In particular  $sFT_1(sI + J_0)^{-1}S_1A_K^{-1}B \rightarrow 0$  as  $s \rightarrow 0$  if and only if  $FT_1(sI + J_0)^{-1}S_1A_K^{-1}B$  is actually the zero transfer function or, equivalently, the triple  $(FT_1, J_0, S_1A_K^{-1}B)$  has no states which are both controllable and observable.

*Corollary 3.1*

Let the Jordan normal form of the matrix  $A_K^{-1}BK_1C$  be given by

$$T^{-1}(A_K^{-1}BK_1C)T = \begin{bmatrix} J_0 & 0 \\ 0 & J_0 \end{bmatrix} \tag{45}$$

where  $J_0$  contains all Jordan blocks associated with the eigenvalue 0 according to the partitionings

$$T = [T_1 \ T_2], \quad T^{-1} = \begin{bmatrix} S_1 \\ S_2 \end{bmatrix} \tag{46}$$

Then time recovery is obtained if and only if

$$FT_1(S_1A_K^{-1}B, J_0S_1A_K^{-1}B, \dots, J_0^{n-1}S_1A_K^{-1}B) = 0 \tag{47}$$

The condition on  $K_1$  for time recovery is not simple, but it will generically be satisfied if  $K_1C$  has full row rank. The full row rank condition for  $K_1C$ , however, is neither necessary nor sufficient.

*3.2. ELTRI and ALTRI with reduced-order P and PI observers*

Consider the reduced-order observer-based control system of Figure 3, and let the plant be left-invertible, minimum phase and have all of its infinite zeros of order one. Then both closed-loop asymptotic stability and ELTRI can be achieved; that is, one can recover exactly the target loop transfer function  $L(s)$ . This is then satisfied if (16) reduces to

$$H = TB = 0 \tag{48}$$

It is well known<sup>4,20</sup> that such a T exists if and only if the matrix product  $CB$  has full rank ( $\det(CB) \neq 0$  for  $m = r$ ), with a free target design. With respect to the partitioning of the system  $\Sigma$  given in (11), the condition for ELTRI given by (48) reduces to

$$B_2 + LB_1 = 0 \tag{49}$$

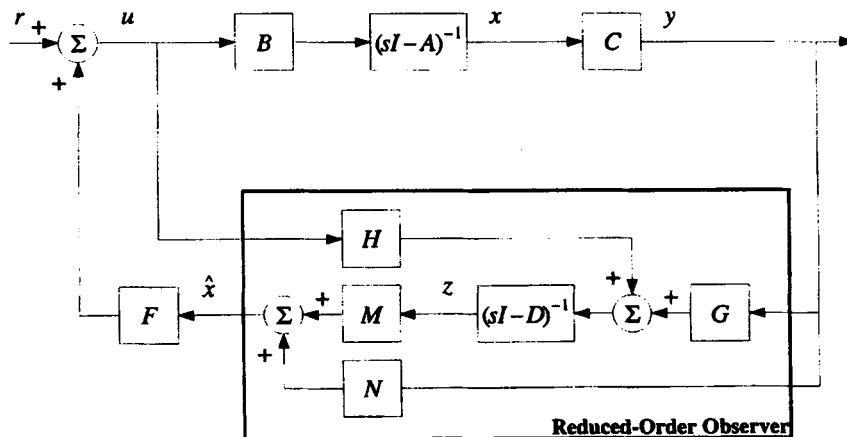

Figure 3

For the reduced-order P observer-based implementation, the sensitivity recovery error, and recovery matrix are given by

$$E_{Sr}(s) = S_{TFL}(s)M_{Ir}(s) \quad (50)$$

$$M_{Ir}(s) = F_2(sI - A_{22} - LA_{12})^{-1}H \quad (51)$$

respectively.<sup>14</sup> Clearly ELTRI is obtained if and only if  $M_{Ir}(s) = 0$  which is satisfied if  $H = 0$ .

The achievement of ELTRI ties into the inherent presence of an output feedback in the reduced-order observer-based implementation (see Figure 3). By moving the summing junction ahead of the gain  $F$  we obtain an output feedback gain  $Q = FN$ , an equivalent of the output term shown by the broken line of Figure 1.

It is of particular interest to investigate the ELTRI design of a reduced-order PI observer. This investigation is reflected in the following result.

### Theorem 3.2

Let the system  $\Sigma$  described by (11) be left-invertible, minimum phase and have all of its infinite zeros of order one (i.e., let  $CB$  have full rank). Then the reduced-order PI observer  $\Sigma_{RPI}$ , described by (24), achieves ELTRI if and only if its corresponding reduced-order P observer  $\Sigma_{RP}$ , described by (13), achieves ELTRI.

*Proof.* The proof follows from the preliminary development of Section 2 and the fact that (24) has the same structure as (13). Thus, ELTRI is achieved by setting the expression for  $H_E$  in (27) equal to zero, i.e.,

$$H_E = S_E + L_E B_1 = T_E B = 0 \quad (52)$$

where

$$T_E = \begin{bmatrix} L_P & I_{n-m} \\ L_I & 0 \end{bmatrix} \quad (53)$$

The condition (52) is similar to the condition for ELTRI with a reduced-order P observer and reduces to

$$B_2 + L_P B_1 = 0 \quad (54)$$

$$L_I B_1 = 0 \quad (55)$$

Consequently, we have  $L_I = 0$ , and (54) is exactly the same as (49) with  $L_p = L$ . This completes the proof.  $\square$

Next, define the loop recovery error, sensitivity recovery error, and recovery matrix for the reduced-order PI observer-based implementation by

$$E_{SR}(s) = S_{TFL}(s)M_{IR}(s) \quad (56)$$

$$M_{IR}(s) = F_{2E}(sI - D_E)^{-1}H_E \quad (57)$$

respectively, with  $F_{2E} = [F_2 \ 0]$ . Then we have the following result.

### Corollary 3.2

$E_{SR}(s) = 0$ , and  $M_{IR}(s) = 0$  if and only if  $E_{Sr}(s) = 0$ , and  $M_{Ir}(s) = 0$ .

*Proof.* The proof is obvious in view of Theorem 3.2.  $\square$

Since  $M_{IR}(s)$  or  $M_{IR}(s)$  cannot, in general, be made zero, researchers have focused attention on ALTRI. To this end, we may employ the full-order observer-based ALTRI techniques described in Section 3.1 for the reduced-order observer as well; however, we shall not further elaborate here.

#### 4. LQG/LTR DESIGN OF PI OBSERVERS

As we discussed in Section 3.1, there are various observer-based LTR design techniques. We can classify these techniques into two categories: those involving structural changes to the basic observer architecture and those not. A separate publication<sup>21</sup> discusses this classification and the design methods based on structural changes. This section derives the LTR design of PI observers based on the LQG method. First we shall apply the LQG method to the PI observer, and thereafter we shall extend the familiar LQG/LTR method for full-order P observers<sup>25</sup> to handle the PI observer case. Both the asymptotic and nonasymptotic cases will be analysed.

##### 4.1. LQG design

The standard LQG design method can be directly applied to the PI observer. The observer gain  $K_x$  is given simply by

$$K_x = \begin{bmatrix} K_P \\ K_I \end{bmatrix} = -PC_x^T \Sigma^{-1} \quad (58)$$

where  $P$  is the positive definite solution of the algebraic Riccati equation

$$A_x P + PA_x^T + \Gamma - PC_x^T \Sigma^{-1} C_x P = 0 \quad (59)$$

with  $\Gamma = L^T L \geq 0$  and  $\Sigma \geq 0$  being the given weighting matrices.

Let the Riccati solution  $P$  be partitioned as follows:

$$P = \begin{bmatrix} P_{11} & P_{12} \\ P_{12}^T & P_{22} \end{bmatrix} \quad (60)$$

then the observer gain takes the following form:

$$K_x = \begin{bmatrix} K_P \\ K_I \end{bmatrix} = - \begin{bmatrix} P_{11} & P_{12} \\ P_{12}^T & P_{22} \end{bmatrix} \begin{bmatrix} C^T \\ 0 \end{bmatrix} \Sigma^{-1} = - \begin{bmatrix} P_{11} C^T \Sigma^{-1} \\ P_{12}^T C^T \Sigma^{-1} \end{bmatrix} \quad (61)$$

Equation (61) shows that  $K_I$  has full rank, hence time recovery is obtained, if and only if  $CP_{12}$  has full rank.

The condition for  $K_I$  to have full rank can be derived from (59). This Riccati equation is equivalent to four (effectively three) equations given by

$$AP_{11} + P_{11}A^T + BP_{12}^T + P_{12}B^T + P_{11}C^T \Sigma^{-1} CP_{11} - L_1^T L_1 = 0 \quad (62)$$

$$AP_{12} + BP_{22} + P_{11}C^T \Sigma^{-1} CP_{12} - L_1^T L_2 = 0 \quad (63)$$

$$P_{12}^T C^T \Sigma^{-1} CP_{12} - L_2^T L_2 = 0 \quad (64)$$

where

$$\Gamma = \begin{bmatrix} \Gamma_{11} & \Gamma_{12} \\ \Gamma_{21} & \Gamma_{22} \end{bmatrix} = \begin{bmatrix} L_1^T \\ L_2^T \end{bmatrix} [L_1 \ L_2] \quad (65)$$

Equation (64) implies that  $CP_{12}$  has full rank if and only if  $\Gamma_{22} = L_2^T L_2$  is positive definite, i.e. iff  $L_2$  is injective; therefore, LQG design of a PI observer, in general, yields time recovery if the weighting matrix  $\Gamma_{22}$  is positive definite.

4.2. LQG/LTR design of PI observers for minimum phase systems

Let us instead apply the LQG/LTR method to the PI observer. As in References 5 and 6 let the weighting matrices  $\Gamma$  and  $\Sigma$  in (59) be given by

$$\Gamma = \Gamma_0 + q^2 B_x V B_x^T, \quad \Gamma_0 \geq 0, \quad V > 0, \quad 0 \leq q < \infty \tag{66}$$

$$\Sigma = \Sigma_0, \quad \Sigma_0 > 0 \tag{67}$$

respectively. In the limit the observer gain behaves as follows:

$$\frac{K_x}{q^2} \rightarrow -B_x V^{1/2} \Theta \Sigma^{1/2} = -\begin{bmatrix} B \\ 0 \end{bmatrix} V^{-1/2} \Theta \Gamma^{-1/2} \quad \text{as } q \rightarrow \infty \tag{68}$$

where  $\Theta$  is an orthogonal matrix. Equation (68) shows that  $K_1$  is zero in the limit. Hence, the PI observer reduces to a full-order P observer without time recovery effects.

It is not surprising that the time recovery effect disappears in the LQG/LTR design as  $q$  tends to infinity. In the limit we obtain asymptotic recovery for minimum phase systems,<sup>14</sup> hence, good recovery for all frequencies. The integral effect (time recovery effect), therefore, vanishes in the recovery process. This result can also be seen by rewriting the recovery matrix in (39) as follows:

$$M_1(s) = sF(sI - A - K_p C)^{-1} B (sI - K_1 C (sI - A - K_p C)^{-1} B)^{-1} \tag{69}$$

As  $q \rightarrow \infty$  in (68) the P observer gain  $K_p$  behaves like the usual, full-order observer, LQG/LTR design gain. In the minimum phase case, the two transfer functions  $F(sI - A - K_p C)^{-1} B$  and  $C(sI - A - K_p C)^{-1} B$  both approach zero as  $q \rightarrow \infty$ . Thus from (69) we see that  $M_1(s)$  also approaches zero.

Another way to verify the vanishing of the time recovery effect as  $q \rightarrow \infty$  is to examine the zeros of the system  $\Sigma_x$ :  $(A_x, B_x, C_x)$ . Since

$$\text{rank} \begin{bmatrix} zI - A & -B & -B \\ 0 & zI & 0 \\ C & 0 & 0 \end{bmatrix} < n + 2m \tag{70}$$

the extended system  $\Sigma_x$  has  $m$  extra zeros at  $z = 0$ . The LQG/LTR method asymptotically places  $m$  poles at the origin which cancel these  $m$  zeros. As a result the time recovery effect vanishes.

Similar to the conclusion arrived at in Theorem 3.2 for reduced-order P and PI observers, we do not receive any benefits by using a full-order PI observer instead of a full-order P observer in recovery design. This conclusion agrees with Reference 15 where it was shown that use of a full-order observer is always sufficient to obtain asymptotic recovery. However, asymptotic recovery will in general result in high observer gains.<sup>24</sup> In practice, therefore, it is difficult to obtain good recovery with a limited observer gain. This limitation of the full-order P observer makes the PI observer interesting from a time recovery point of view. To obtain time recovery we do not necessarily need high gains. Motivated by this fact we derive an LTR design method for the PI observer which allows one to design explicitly for time recovery and frequency recovery (normal recovery).

A modification of the LQG/LTR method allows for time recovery to be achieved in the limit. From (64) the conditions for time recovery are that  $\Gamma_{22} = L_2^T L_2$  be positive definite and  $\Gamma_{22}/q^2$  not

approach zero for a fixed  $q$ . These conditions can be satisfied by including a scalar parameter  $\alpha$  in  $\Gamma_{22}$  such that the I observer gain is designed explicitly. We may include this  $\alpha$ -parameter in  $\Gamma_{22}$  through a number of ways. The simplest way is to change  $B_x$  in the expression for  $\Gamma$  given by (66). Let the recovery weight  $\Gamma$  be given by

$$\Gamma = \Gamma_0 + q^2 B_\alpha V B_\alpha^\top, \quad \Gamma_0 \geq 0, \quad V > 0, \quad 0 \leq q < \infty \quad (71)$$

where

$$B_\alpha = \begin{bmatrix} B \\ \alpha I \end{bmatrix}, \quad \alpha \geq 0 \quad (72)$$

The extra  $m$  poles of the PI observer are now placed at  $p = -\alpha$  (as  $q \rightarrow \infty$ ). This property can be seen by considering the zeros of  $\Sigma_x$ . Note that  $B_\alpha$  need not be given by (72). As an alternative to the identity matrix for the extended states, one could use any regular matrix having positive eigenvalues.

To summarize the LQG/LTR design method for PI observers, we give the following theorem.

#### Theorem 4.1

An LQG/LTR design of the PI observer described by (7), (8), (9) can be done in the following way: Let the observer gain be given by

$$K_x = -PC_x^\top \Sigma^{-1} \quad (73)$$

where  $P$  is the positive definite solution to

$$A_x P + P A_x^\top + \Gamma - PC_x^\top \Sigma^{-1} C_x P = 0 \quad (74)$$

with the weighting matrices  $\Gamma$  and  $\Sigma$  specified, respectively, by

$$\Gamma = \Gamma_0 + q^2 B_\alpha V B_\alpha^\top, \quad \Gamma_0 \geq 0, \quad V > 0, \quad 0 \leq q < \infty \quad (75)$$

$$\Sigma = \Sigma_0, \quad \Sigma_0 \geq 0 \quad (76)$$

in which

$$B_\alpha = \begin{bmatrix} B \\ \alpha I \end{bmatrix}, \quad \alpha \geq 0 \quad (77)$$

and adjust the degree of time recovery and frequency recovery via the scalars  $\alpha$  and  $q$ , respectively.

For obvious reasons the scalar  $\alpha$  is called the *time recovery parameter* and  $q$ , the *frequency recovery parameter*.

#### 4.3. LQG/LTR design of PI observers for non-minimum phase systems

In general it is impossible to obtain exact or asymptotic recovery for non-minimum phase systems.<sup>14,15</sup> Niemann and Jannerup<sup>11</sup> and Zhang and Freudenberg<sup>29</sup> studied the application of full-order observer-based controllers for non-minimum phase systems and gave explicit forms of the resulting finite recovery error.

With respect to the PI observer, we can also give an explicit expression for the recovery error as  $q$  approaches infinity. To derive such an expression, we need some preliminary results. First consider the systems  $\Sigma$ :  $(A, B, C)$  and  $\Sigma_+$ :  $(A, Z, C)$  where  $\Sigma_+$  is minimum phase. Furthermore, let the

recovery matrix of a full-order observer-based design for  $\Sigma$  be given by (34). Now let the observer gain satisfy

$$\frac{K}{q} \rightarrow ZW, \det(W) \neq 0 \text{ as } q \rightarrow \infty \quad (78)$$

We have the following result.

*Lemma 4.1*

Let the full-order P observer gain  $K$  satisfy (78). The limit value of  $M_1(s)$  is then given by

$$M_1(s) = F(sI - A)^{-1}(B - Z(C(sI - A)^{-1}Z)^{-1}C(sI - A)^{-1}B) \quad (79)$$

*Proof.* See Appendix B. □

If the two systems  $\Sigma$  and  $\Sigma_z$  are related by  $Z = B_m$  where  $B_m$  satisfies

$$G(s) = C(sI - A)^{-1}B = C(sI - A)^{-1}B_m B_z(s) = G_m(s)B_z(s) \quad (80)$$

we obtain a more familiar form of the limit value of the recovery matrix given by

$$M_1(s) = F(sI - A)^{-1}(B - B_m B_z(s)) \quad (81)$$

This result is the same as found in Reference 29.

If the factorization in (80) is an all-pass factorization,  $B_m$  and  $B_z(s)$  can be calculated in two ways. The first method is iterative<sup>29</sup> and  $B_m$  and  $B_z(s)$  are given by

$$B_m^i = B_m^{i-1} - 2\text{Re}(z_i) \xi_i \eta_i^T \quad (82)$$

$$B_z(s) = I - \frac{2\text{Re}(z_i)}{s + z_i} \eta_i \eta_i^T \quad (83)$$

respectively, where  $\eta_i$  and  $\xi_i$  are solutions of

$$\begin{bmatrix} z_i I - A & -B_m^{i-1} \\ -C & 0 \end{bmatrix} \begin{bmatrix} \xi_i \\ \eta_i \end{bmatrix} = 0, \quad \eta_i^T \eta_i = 1 \quad (84)$$

and  $z_1, z_2, \dots, z_l$  are the non-minimum phase zeros of  $\Sigma$ . We further note that

$$G_m(s) = G_m^l(s) = C(sI - A)^{-1}B_m^l \quad (85)$$

$$B_z(s) = B_{z_1}(s)B_{z_2}(s) \dots B_{z_l}(s) \quad (86)$$

The second method is based on solving a 'dissipation inequality' which appears in singular  $\mathcal{H}_2$  control; see Reference 26. A  $B_m$  for the all-pass factorization is given by:

$$(i) \quad \dot{A}Q + QA^T + BB^T = B_m B_m^T \geq 0 \quad (87)$$

$$(ii) \quad \text{rank } B_m = \text{rank } B \quad (88)$$

$$(iii) \quad \text{rank} \begin{pmatrix} sI - A & B_m \\ -C & 0 \end{pmatrix} = n + \text{normrank } G(s), \forall s \in \mathbb{C}^+ \quad (89)$$

for a (unique)  $Q \geq 0$  satisfying the above three conditions. In this case  $B_z(s)$  can only be calculated implicitly from

$$G(s) = G_m(s)B_z(s)$$



An algorithm for calculating  $Q$  and  $B_m$  satisfying (i) through (iii) can be found in Reference 13.

Based on Lemma 4.1 and the 'quadratic matrix inequality', we now give an explicit expression for the recovery matrices as  $q \rightarrow \infty$  in the LQG/LTR design of a PI observer.

*Theorem 4.2*

Let the PI observer gain  $K_x$  be designed by the LQG/LTR method of Theorem 4.1. As  $q \rightarrow \infty$  the recovery matrix approaches

$$M_1(s) = F(sI - A)^{-1} \left[ B - \left( B_{\alpha m} + \frac{\alpha}{s} B \right) \left( C \Phi(s) B_{\alpha m} + \frac{\alpha}{s} C \Phi(s) B \right)^{-1} C \Phi(s) B \right] \quad (90)$$

or

$$M_1(s) = F(sI - A)^{-1} \left[ B - \left( \frac{s}{\alpha} B_{\alpha m} + B \right) \left( \frac{s}{\alpha} C \Phi(s) B_{\alpha m} + C \Phi(s) B \right)^{-1} C \Phi(s) B \right] \quad (91)$$

where  $B_{\alpha m}$  satisfies

$$C_x(sI - A_x)^{-1} B_{\alpha}(s) = C_x(sI - A_x)^{-1} \begin{pmatrix} B_{\alpha m} \\ \alpha I \end{pmatrix} B_z(s) \quad (92)$$

*Proof.* Using  $A = A_x$ ,  $B = B_x$ ,  $F = F_x$  and

$$Z = \begin{pmatrix} B_{\alpha m} \\ \alpha I \end{pmatrix}$$

in Lemma 4.1, the above recovery matrix appears immediately by using the 'dissipation inequality' method.  $\square$

Note that (90) reduces to the recovery matrix in (81) when  $\alpha = 0$ . As a direct consequence of Theorem 4.2 we have:

*Corollary 4.1*

Consider a PI observer with gain  $K_x$  as above. Then

$$M_1(0) = 0$$

and time recovery is obtained.

It is important to note that the time recovery effect also appears in the non-minimum phase case.

## 5. EXAMPLE

For the purpose of illustration consider the following second-order plant:

$$G(s) = \frac{s + b}{s^2 + 4s + 3} \quad (93)$$

5.1. Case 1: Minimum phase plant ( $b = 2$ )

A minimal realization for  $G(s)$  is given by

$$A = \begin{bmatrix} 0 & 1 \\ -3 & -4 \end{bmatrix}, \quad B = \begin{bmatrix} 0 \\ 1 \end{bmatrix}, \quad C = [2 \ 1] \tag{94}$$

and the target design (full-state feedback) is given by  $u = Fx$  with  $F = [-50 \ -10]$ . Let the nominal weighting matrices for the LQG/LTR design given in (66) and (67) be specified by  $\Gamma_0 = I$  and  $\Sigma_0 = 1$ , respectively.

Figure 4 compares the recovery matrix  $M_1(s)$  of an LQG/LTR design of a conventional full-order P observer with  $q = 1000$  to that of an LQG/LTR design of a PI observer (with  $q = 1000$ ) for several values of  $\alpha$ . The main difference between the two implementations appears at low frequencies where the integral effect of the PI observer-based implementation yields significantly smaller recovery matrix gain, i.e. time recovery is obtained.

The gain of the recovery matrix at high frequencies is independent of the selected  $\alpha$ -parameter. If we increase  $q$  the norm of the P observer gain  $K_p$  increases. In the same manner the norm of the I observer gain  $K_i$  increases as we increase  $\alpha$ . However, for PI implementations we do not need high observer gains for obtaining time recovery.

5.2. Case 2: Non-minimum phase plant ( $b = -2$ )

Here a minimal realization for  $G(s)$  is given by

$$A = \begin{bmatrix} 0 & 1 \\ -3 & -4 \end{bmatrix}, \quad B = \begin{bmatrix} 0 \\ 1 \end{bmatrix}, \quad C = [-2 \ 1] \tag{95}$$

with the same full-state feedback gain for the target design as in the minimum phase case. Since the non-minimum phase zero frequency (2 rad/s) is within the desired or target feedback loop

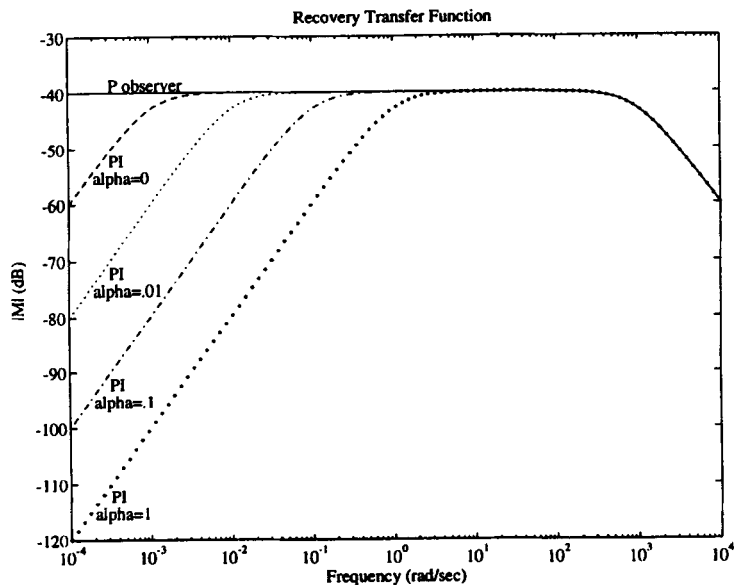

Figure 4

(TFL) bandwidth (10 rad/s), we expect conventional LQG/LTR design to fail to recover the loop properties. However, using LQG/LTR design of a PI observer we expect some degree of recovery in the low-frequency range by tweaking the  $\alpha$ -parameter.

We apply the conventional LQG/LTR method with  $q = 1000$  and compare the resulting P observer-based design to a PI observer-based design obtained by our modified LQG/LTR

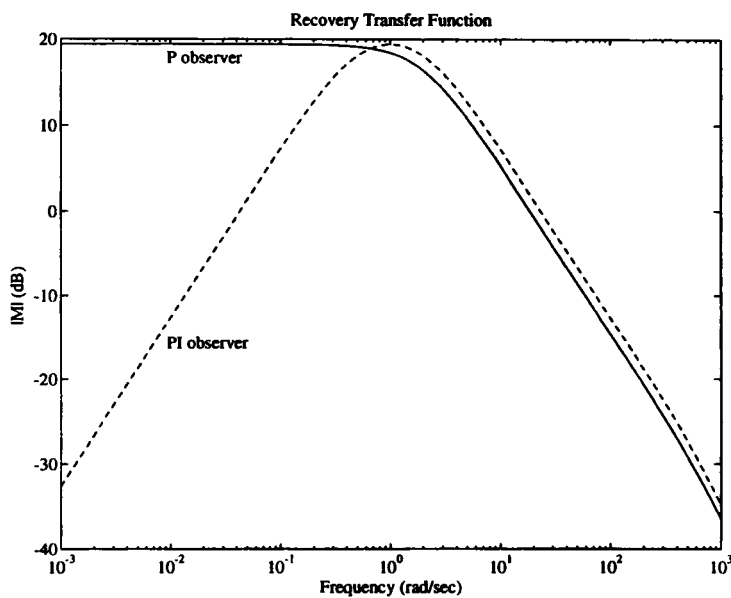

Figure 5

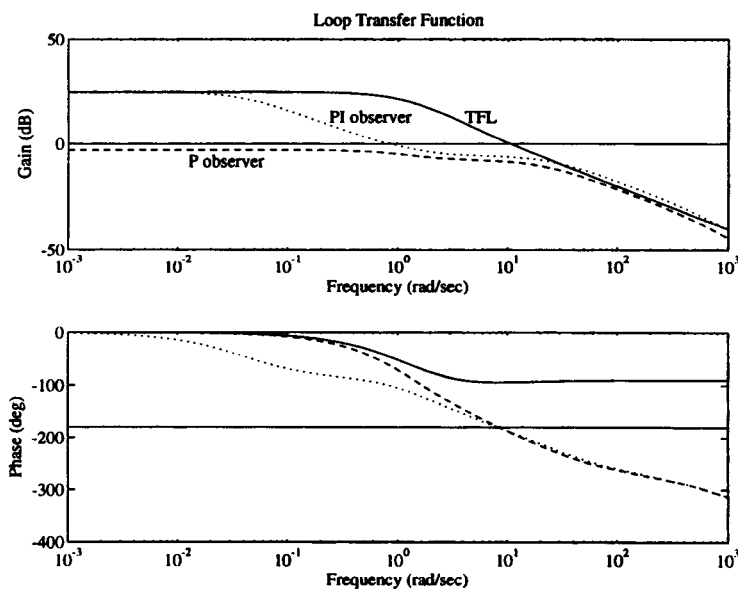

Figure 6

method with  $q = 1000$ ,  $\alpha = 0.5$ . Figure 5 shows the recovery matrix gain for the two observer types, and Figure 6 shows the loop transfer function for the three implementations (target full loop given by  $F(sI - A)^{-1}B$  and the full loop for the P and the PI observers given by  $C(s)G(s)$ ). As expected the P observer-based LQG/LTR design fails to recover the TFL (for any value of  $q$ ); however, our method shows some degree of recovery at low frequencies as well as excellent

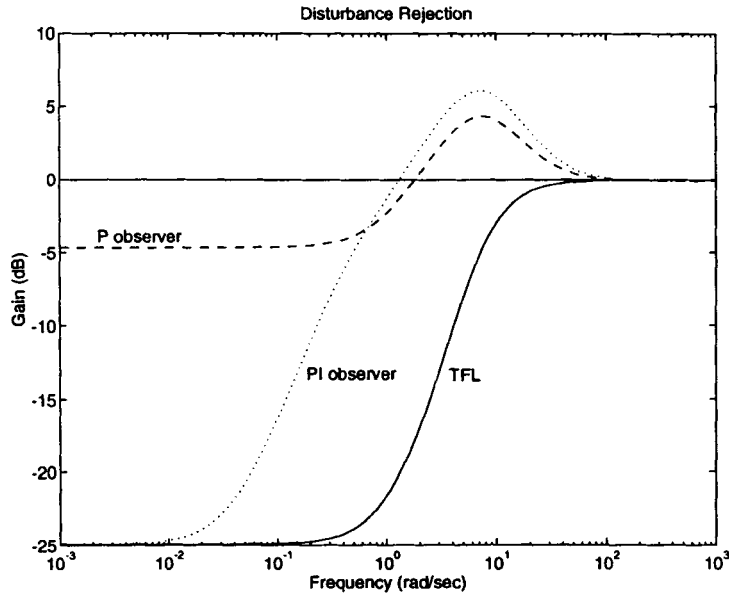

Figure 7

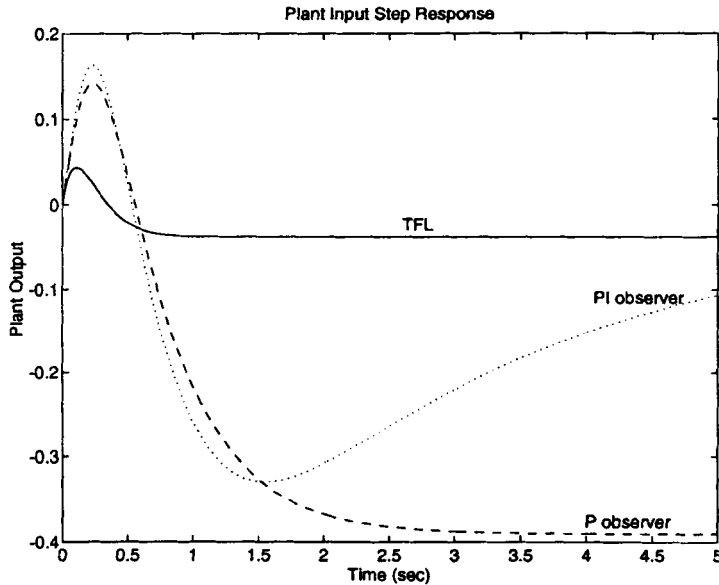

Figure 8

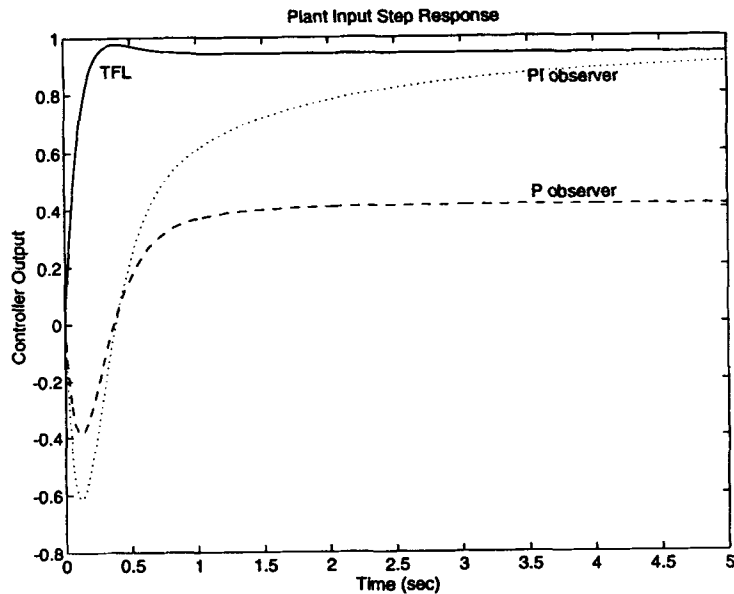

Figure 9

phase margin ( $80^\circ$ ). The improvement at low frequencies is further illustrated in Figure 7 which shows the disturbance rejection (at the plant input), i.e. the sensitivity functions, for the three implementations. It is important to note the difference between the transfer functions at low frequencies for the two observer implementations. In the PI observer case, the target loop is recovered quite well, except from the frequency range from 0.02 rad/s to 8 rad/s, whereas the P observer gives poor recovery for frequencies below 8 rad/s. Figures 8 and 9 show the plant input step responses (step applied at the plant input) with respect to plant output and controller output, respectively. Again, it can be seen clearly that the PI observer results in time recovery, i.e. exact recovery in steady state.

## 6. CONCLUSION

This paper presented the continuous time full-order and minimal-order PI observer. Both LQG and LQG/LTR design methods were derived for the full-order PI observer with special attention to the time recovery effect of the PI observer. Necessary and sufficient conditions for achieving LTR and time recovery in PI observer-based systems were given.

Our analysis shows that the time recovery effect appears, in both the minimum and non-minimum phase cases, when standard LQG design is applied for PI observers. We also show that there are no advantages in using PI observers when the LTR design tend to the limit for minimum phase systems or when the standard LQG/LTR method is applied to non-minimum phase systems. Instead, the standard LQG/LTR method has been modified such that we can design for time recovery and frequency recovery independently. This independence makes it possible to obtain time recovery in LTR design.

The LTR results presented in this paper are all obtained with respect to the plant input point.

When the LTR design method is applied with respect to the plant output point, the target design turn out to be a normal full-order observer design. The LTR step will then be a recovery design of a PI state feedback gain, i.e. the dual of a PI observer.

## ACKNOWLEDGEMENT

This work is supported in part by the Danish Technical Research Council under grant no. 26-1830.

## APPENDIX A: PROOF OF THEOREM 3.1

Since  $A_K$  is stable,  $sF(s^2I - sA_K - BHC)^{-1}B \rightarrow 0$  as  $s \rightarrow 0$  if and only if  $sF(sA_K + BHC)^{-1}B \rightarrow 0$  as  $s \rightarrow 0$  or, equivalently, if and only if  $sF(sI + A_K^{-1}BHC)^{-1}A_K^{-1}B \rightarrow 0$  as  $s \rightarrow 0$ . Only states which are both controllable and observable are relevant to time recovery. Hence, we can assume without loss of generality that the triple  $(F, A_K^{-1}BHC, A_K^{-1}B)$  is both observable and controllable. Let a similarity transformation  $T$  be given such that

$$T^{-1}(A_K^{-1}BHC)T = \begin{bmatrix} J_0 & 0 \\ 0 & \bar{J} \end{bmatrix} \quad (96)$$

where  $J_0$  is a matrix of Jordan blocks associated with the eigenvalue 0,  $\bar{J}$  is a nonsingular matrix, and  $T, T^{-1}$  have the associated partitionings

$$T = [T_1 \ T_2], \quad T^{-1} = \begin{bmatrix} S_1 \\ S_2 \end{bmatrix} \quad (97)$$

respectively. Now we have

$$sF(sI + A_K^{-1}BHC)^{-1}A_K^{-1}B = sF[T_1 \ T_2] \left( sI + \begin{bmatrix} J_0 & 0 \\ 0 & \bar{J} \end{bmatrix} \right)^{-1} \begin{bmatrix} S_1 \\ S_2 \end{bmatrix} A_K^{-1}B \quad (98)$$

$$= sFT_1(sI + J_0)^{-1}S_1A_K^{-1}B + sFT_2(sI + \bar{J})^{-1}S_2A_K^{-1}B \quad (99)$$

Clearly  $sFT_2(sI + \bar{J})^{-1}S_2A_K^{-1}B \rightarrow 0 \cdot FT_2\bar{J}^{-1}S_2A_K^{-1}B = 0$  as  $s \rightarrow 0$ . Hence,

$$\lim_{s \rightarrow 0} sF(s^2I + sA_K + BHC)^{-1}B = \lim_{s \rightarrow 0} sFT_1(sI + J_0)^{-1}S_1A_K^{-1}B \quad (100)$$

$$= \begin{cases} FT_1S_1A_K^{-1}B & \text{if } J_0 = 0 \\ \infty & \text{if } J_0 \neq 0 \end{cases} \quad (101)$$

Because of the controllability and observability assumption on  $(F, A_K^{-1}BHC, A_K^{-1}B)$  we have  $FT_1S_1A_K^{-1}B \neq 0$ . This completes the proof.

## APPENDIX B: PROOF OF LEMMA 4.1

$$\begin{aligned} M_1(s) &= F(sI - A - KC)^{-1}B \\ &= F(sI - A)^{-1}(I - KC(sI - A)^{-1})^{-1}B \\ &= F(sI - A)^{-1}[I + KC((sI - A)^{-1} - KC)^{-1}]B \\ &= F(sI - A)^{-1}[I + K(I - C(sI - A)^{-1}K)^{-1}C(sI - A)^{-1}]B \end{aligned}$$

Using

$$K = qZW$$

we get

$$\begin{aligned} M_1(s) &= F(sI - A)^{-1}[I + qZW(I - C(sI - A)^{-1}qZW)^{-1}C(sI - A)^{-1}]B \\ &= F(sI - A)^{-1}[I + Z(q^{-1}W^{-1} - C(sI - A)^{-1}Z)^{-1}C(sI - A)^{-1}]B \end{aligned}$$

Letting

$$q \rightarrow \infty$$

we obtain

$$\begin{aligned} M_1(s) &\rightarrow F(sI - A)^{-1}[I - Z(C(sI - A)^{-1}Z)^{-1}C(sI - A)^{-1}]B \\ &= F(sI - A)^{-1}[B - Z(C(sI - A)^{-1}Z)^{-1}C(sI - A)^{-1}]B \end{aligned}$$

#### REFERENCES

1. Anderson, B. D. O., and J. B. Moore, *Optimal Control, Linear Quadratic Methods*, Prentice-Hall, Englewood Cliffs, NJ, 1989.
2. Athans, M., 'A tutorial on the LQG/LTR method', *Proc. Amer. Contr. Conf.*, Seattle, WA, 1986, pp. 1289–1296.
3. Beale, S., and B. Shafai, 'Robust control system design with a proportional-integral observer', *Int. J. Contr.*, **50**, 97–111 (1989).
4. Beale, S., and B. Shafai, 'Loop transfer recovery via a proportional-integral observer', *Proc. IEEE Int. Conf. on Systems Engineering*, Pittsburgh, PA, 1990, pp. 468–473.
5. Doyle, J., and G. Stein, 'Robustness with observers', *IEEE Trans. Automatic Control*, **AC-24**, 607–611 (1979).
6. Doyle, J., and G. Stein, 'Multivariable feedback design: concepts for a classical/modern synthesis', *IEEE Trans. Automatic Control*, **AC-26**, 4–16 (1981).
7. Goodman, G. C., 'The LQG/LTR method and discrete-time control systems', M.Sc. thesis, rep. no. LIDS-TH-1392, Massachusetts Institute of Technology, Cambridge, MA, 1984.
8. Lee, T. T., and M. S. Chen, 'Robustness recovery of LQG based multivariable control designs', *Int. J. Contr.*, **45**, 1131–1136 (1987).
9. Luenberger, D. G., 'An introduction to observers', *IEEE Trans. Automatic Control*, **AC-16**, 596–602 (1971).
10. Moore, J. B., and T. T. Tay, 'Loop recovery via  $H^\infty/H^2$  sensitivity recovery', *Int. J. Contr.*, **49**, 1249–1271 (1989).
11. Niemann, H. H., and O. Jannerup, 'An analysis of pole/zero cancellation in LTR-based feedback design', *Proc. Amer. Contr. Conf.*, San Diego, CA, 1990, pp. 848–853.
12. Niemann, H. H., and J. Stoustrup, 'Proportional-integral observers used in recovery design', *Proc. Amer. Contr. Conf.*, Chicago, 1992, pp. 1009–1010.
13. Niemann, H. H., and J. Stoustrup, 'Regular vs. singular methods in cheap  $H_\infty$  control: a numerical study', *Proc. European Contr. Conf., ECC-93*, Groningen, The Netherlands, 1993, pp. 733–738.
14. Niemann, H. H., P. Sogaard-Andersen and J. Stoustrup, 'Loop transfer recovery for general observer architectures', *Int. J. Contr.*, **53**, 1177–1203 (1991).
15. Niemann, H. H., P. Sogaard-Andersen and J. Stoustrup, ' $H_\infty$  optimization of the recovery matrix', *Control—Theory and Advances Technology, C-TAT*, **9**, 547–564 (1993).
16. Okada, T., M. Kihara and H. Furihata, 'Robust control system with observer', *Int. J. Contr.*, **45**, 1207–1219 (1985).
17. Okada, T., M. Kihara, M. Ikeda and T. Honma, 'System observer techniques in robust control system design synthesis', in *Control and Dynamic Systems*, Vol. 50, Academic Press, New York, 1992, pp. 79–118.
18. Saberi, A., B. M. Chen and P. Sannuti, *Loop Transfer Recovery: Analysis and Design*, Springer-Verlag, New York, 1993.
19. Saeki, M., ' $H^\infty$ /LTR procedure with specified degree of recovery', *Automatica*, **28**, 509–517 (1992).
20. Shafai, B., L. H. Keel and S. Beale, 'Zero assignment and loop transfer recovery in LQG design', *Proc. 29th IEEE Conf. on Decision and Contr.*, Honolulu, HI, 1990, pp. 1217–1221.
21. Shafai, B., S. Beale, H. H. Niemann and J. Stoustrup, 'Modified structures for loop transfer recovery design', *Proc. 32nd IEEE Conf. on Decision and Contr.*, San Antonio, TX, 1993, pp. 3341–3344.
22. Sogaard-Andersen, P., 'Loop transfer recovery with minimal order observers', *Proc. 26th IEEE Conf. on Decision and Contr.*, Los Angeles, CA, 1987, pp. 933–938.
23. Sogaard-Andersen, P., 'Loop transfer recovery—an eigenstructure interpretation', *Control—Theory and Advanced Technology, C-TAT*, **5**, 351–365 (1989).
24. Sogaard-Andersen, P. and H. H. Niemann, 'Trade-offs in LTR-based feedback design', *Proc. Amer. Contr. Conf.*, Pittsburgh, PA, 1989, pp. 922–928.

25. Stein, G., and M. Athans, 'The LQG/LTR procedure for multivariable feedback control design', *IEEE Trans. Automatic Control*, AC-32, 105–114 (1987).
26. Stoorvogel, A. A., 'The singular  $\mathcal{H}_2$  control problem', *Automatica*, 28, 627–631 (1992).
27. Stoustrup, J., and H. H. Niemann, ' $H_\infty$ /LTR observer based controllers: direct and indirect design methods', *Proc. IEE Int. Conf. on Control-91*, Edinburgh, Scotland (1991), pp. 190–195.
28. Stoustrup, J., and H. H. Niemann, 'State space solutions to the  $H_\infty$ /LTR design problem', *Int. J. Robust and Nonlinear Control*, 3, 1–45 (1993).
29. Zhang, Z., and J. S. Freudenberg, 'Loop transfer recovery for non-minimum phase plants', *IEEE Trans. Automatic Control*, AC-35, 547–553 (1990).