



Design and In-Vivo Test of Battery-Free Implantable Temperature Sensor Based on Magnetic Resonant Wireless Power Transfer

Hua, Qirui; Ryttoft, Laura Amalie; Krøyer, Ben Klauman; Rahbek, Ole; Kold, Søren Vedding; Shen, Ming

Published in:
2022 IEEE Nordic Circuits and Systems Conference (NorCAS)

DOI (link to publication from Publisher):
[10.1109/NorCAS57515.2022.9934626](https://doi.org/10.1109/NorCAS57515.2022.9934626)

Publication date:
2022

Document Version
Accepted author manuscript, peer reviewed version

[Link to publication from Aalborg University](#)

Citation for published version (APA):

Hua, Q., Ryttoft, L. A., Krøyer, B. K., Rahbek, O., Kold, S. V., & Shen, M. (2022). Design and In-Vivo Test of Battery-Free Implantable Temperature Sensor Based on Magnetic Resonant Wireless Power Transfer. In J. Nurmi, D. T. Wisland, S. Aunet, & K. Kjelgaard (Eds.), *2022 IEEE Nordic Circuits and Systems Conference (NorCAS)* (pp. 1-6). IEEE (Institute of Electrical and Electronics Engineers). <https://doi.org/10.1109/NorCAS57515.2022.9934626>

General rights

Copyright and moral rights for the publications made accessible in the public portal are retained by the authors and/or other copyright owners and it is a condition of accessing publications that users recognise and abide by the legal requirements associated with these rights.

- Users may download and print one copy of any publication from the public portal for the purpose of private study or research.
- You may not further distribute the material or use it for any profit-making activity or commercial gain
- You may freely distribute the URL identifying the publication in the public portal -

Take down policy

If you believe that this document breaches copyright please contact us at vbn@aub.aau.dk providing details, and we will remove access to the work immediately and investigate your claim.

Design and In-Vivo Test of Battery-Free Implantable Temperature Sensor Based on Magnetic Resonant Wireless Power Transfer

Qirui Hua^{*1}, Laura Amalie Rytøft², Ben Klauman Krøyer¹,
Ole Rahbek², Søren Vedding Kold^{*2} and Ming Shen^{*1}

¹Department of Electronic Systems, Aalborg University, Denmark

²Department of Clinical Medicine, Aalborg University Hospital, Denmark

*Email: qihu@es.aau.dk, sovk@rn.dk, mish@es.aau.dk

Abstract—The in-body operation of implantable medical devices (IMDs) bring the challenge of delivering power conveniently and safely from outside of the body-contact distance through obstacles, including skin and tissue. Magnetic resonance-based wireless power transfer (WPT) provides a promising solution for IMDs, featured by its high-power transfer efficiency at mid-range distances. However, to our knowledge, very few works have investigated the performance of the resonance-based method for transferring power to sensors in vivo. Therefore, in this paper, we design an IMD powered by a WPT system and carry out an in-vivo experiment on the device. This IMD is a Bluetooth module integrated with a temperature sensor and its power is provided by a 3-coil magnetic resonance-based WPT system without batteries. Through the in-vivo experiment on a pig, we successfully apply the WPT system to power the implanted sensor for wireless in-body temperature monitoring. The results demonstrate that the examined 3-coil coupled magnetic resonance WPT method can meet the power requirement and ensure the functional operations of the implanted temperature sensor. Consequently, the capability and feasibility of the magnetic resonance approach for powering in-vivo IMDs are verified, paving the way for the future design and applications of implantable sensors.

Index Terms—Power Transfer, Magnetic Resonance Coupling, Implantable Medical Device, Temperature Sensor, In-Vivo Test

I. INTRODUCTION

Electronic implantable medical devices (IMDs) are able to operate specific functions inside the human body, breaking the limits of traditional methods and offering the possibility to treat and diagnose various types of diseases. This technology has been widely applied in capsule endoscopy [1], pacemaker [2], visual prostheses [3] and bone fracture healing [4], benefiting lots of patients. But the difficulty of harvesting sufficient power for the operation of implants raises a critical challenge for their development. Using batteries is the most common traditional way to supply power, but it is not a promising solution due to the risk of chemical leakage and short lifetimes [5], [6]. In addition, advances in integrated circuit (IC) manufacturing have driven the miniaturisation of implantable sensors, so batteries are being replaced in most integrated sensors to save space [7].

Transferring power wirelessly is a reliable solution for implantable devices, which guarantees security and convenience, and therefore, in recent years, wireless power transfer (WPT) systems are increasingly popular for electronic biomedical implants [1], [8], [9]. With acceptable efficiency, the power can be delivered by a transmitter outside the body to the implanted device. Its dimension, operating duration and safety factor is promising, as no batteries or additional surgeries are required. With the consideration of these factors, the inductive method,

which is featured by small dimension for implants, acceptable efficiency and low tissue absorption of energy, is competitive compared to other WPT methods, including ultrasonic, optical, and capacitive coupling methods [10]. Hence, the inductive technique attracts lots of attention and is regarded as a popular option to realize WPT for IMDs. In an inductive power transfer (IPT) system, power is transferred through the magnetic field, which is created by the oscillating AC current in a primary coil at a certain distance from the implanting site. The secondary coil in the near field converts the changing fields to current to the IMD thanks to induction according to Faraday's Law. The operating frequency of the current, transmission distance and inductive coupling between the primary coil and secondary coil determine the power transfer efficiency (PTE) [11]. However, the design of IMDs requires a reduced size of the power receiver and a wide coverage range to supply power safely and conveniently, which causes difficulty in reaching strong coupling for high PTE. In addition, the attenuation of the electromagnetic field caused by biological tissue also degrades the PTE in the inductive link. These factors may raise a challenge for the inductive-based WPT system to deliver enough power for the electronic implantable device, especially for mid-range applications where the transmission distance is larger than the size of the receiver coil.

Aiming at higher delivered power and extended powering range, in the past decade, the magnetic resonance coupling (MRC) method is proposed for IPT systems by introducing resonance capacitors and additional resonator coils [12]. Operating at a specific frequency, capacitors connected to the coils can resonate out the leakage inductance of the coils so that the reactive impedance is eliminated and more active power can be delivered to the load. Furthermore, based on the maximum power transfer principle, the use of resonator coils contributes to the matching of the source impedance and load impedance and increases the power delivered to the load (PDL) [6], [11]. According to [13], it may sacrifice the overall PTE to achieve maximum PDL by impedance matching. But in mid-range applications, it is possible to realize both high PTE and PDL in a 3-coil coupled magnetic resonance WPT system [11]. It is because the resonator coil helps to reduce the requirement for the load quality factor to reach impedance matching while an extremely high quality factor sometimes is not feasible to realize. By optimising the design, the MRC method for WPT provides higher PDL and therefore, makes it possible to increase the transmission range with the same transmitted power. Increased power output also offers the possibility to reduce the dimension of WPT circuits and to

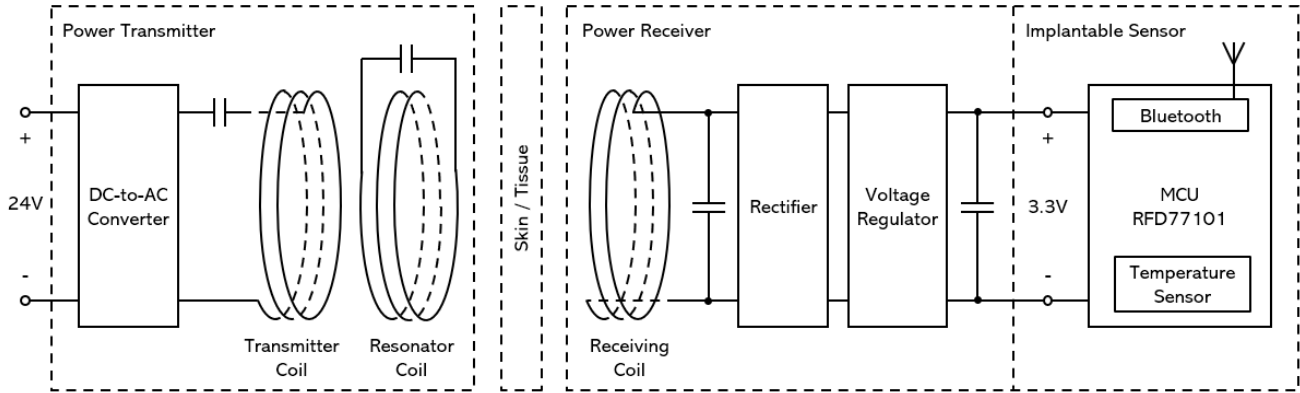

Fig. 1. System overview, including a power transmitter, a power receiver and an implantable sensor.

realize miniaturized ICs as biomedical implants.

A number of researchers investigate the practicability of adopting the magnetic resonance coupling WPT (MRC-WPT) system to power up IMDs [1], [14], [15], including one of our previous works [16]. However, considering the power dissipation in the tissue, the performance of the magnetic resonant system in free space may not be guaranteed for implants inside the body, so it is essential to test the system through an ex-vivo or in-vivo study with real animal tissue or tissue-mimicking materials. Throughout the literature, most research has verified the magnetic resonance-coupled method with ex-vivo experiments while few of them have been tested with the in-vivo experiment. As the real environment of an implant is more complicated, which may have an unexpected influence on the WPT system, it is of importance to have an animal in-vivo experiment to validate the performance of the MRC method, convincingly showing its ability to drive an implantable sensor and the distance it can cover.

As an extension of our previous work [16], in this paper, we report an in-vivo experiment of a wireless-powered implantable temperature sensor to demonstrate the in-body performance of the MRC-WPT system for maximum transfer power. The WPT module is implemented by a 3-coil coupled magnetic resonance method to achieve good driving ability and a wide delivery range, together with peripheral power conversion circuits as shown in Fig. 1. Besides, the complete tested system also includes an implantable microchip sensor, an RFD77101 Bluetooth Low Energy (BLE) System on chip (SoC) integrated with a temperature sensor, which leverages the transferred power to collect the in-body thermal parameter.

Firstly, the temperature measurement performance of the sensor powered wirelessly by the proposed 3-coil MRC-WPT system is evaluated by an ex-vivo experiment. We then conduct the in-vivo experiment implanting the wireless device near and inside the tibia of a pig's leg to demonstrate the applicability of the WPT system. The wireless measurement of the internal temperature of the pig by the implanted microchip sensor is achieved, including acquiring reliable temperature data at desired sites and sending data to a laptop through a BLE connection. Such a result indicates that the proposed 3-

coil magnetic resonant WPT system can support the in-body operation of an IMD by supplying sufficient power wirelessly without using batteries. To the best of our knowledge, this work represents the first in-vivo experiment of the implantable device powered by the 3-coil MRC method, which proves it to be a promising WPT solution for IMDs and paves the path for future design toward multiple types of implantable sensors.

II. SYSTEM DESCRIPTION

A. System Overview

To evaluate the 3-coil MRC-WPT architecture, an IMD for temperature sensing is utilized for demonstration. It is powered up by the proposed method in [16] with no need for batteries. In total, the overall system is composed of a WPT module and an implantable sensor module, as shown in Fig. 1. The WPT module consists of a power transmitter and a receiver, where the receiver side is connected to the sensor part for the power supply. Furthermore, the implantable sensor module is a BLE SoC with a built-in ARM Cortex M0 microcontroller (MCU) and a temperature sensor.

According to [6] and [11], multi-coil WPT systems based on magnetic resonance coupling can promote transmission efficiency for mid-range applications. In particular, the 3-coil system contributes to the highest power delivered to the load (PDL), which is 1.5 times higher than that of the traditional 2-coil system at a distance of 12cm. In addition to its performance, using a 3-coil system also can reduce the volume by saving a resonator coil from the receiving side compared to the 4-coil system. As a result, the 3-coil system is chosen for the design and experiment.

The WPT system leverages 3 planar coils for the magnetic resonance coupling, among which the transmitter coil and the resonator coil on the power transmitter side are much larger than the receiver coil on the power receiver side. At the transmitter side, a 24V DC input is converted to AC as the power source for the transmitter coil to generate the magnetic field. Through this magnetic field, the resonator coil is strongly coupled with the transmitter coil to enhance power transfer and the electromagnetic induction at the receiver coil generates AC current. The AC power acquired wirelessly through the skin

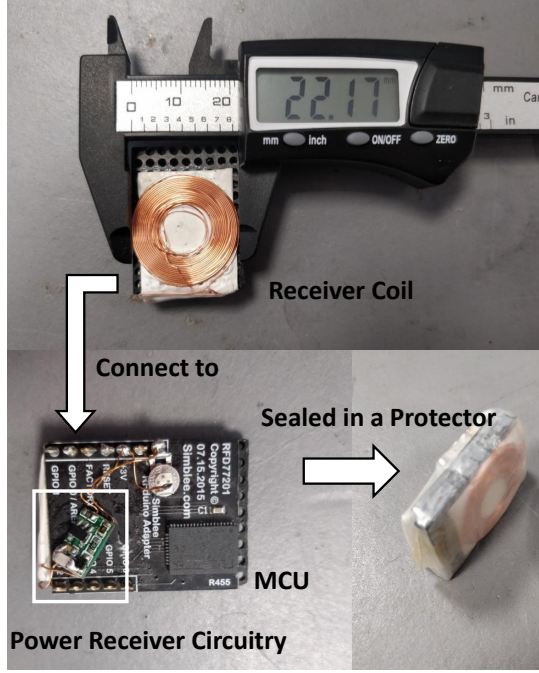

Fig. 2. Wireless implantable device, powered by the wireless power transfer.

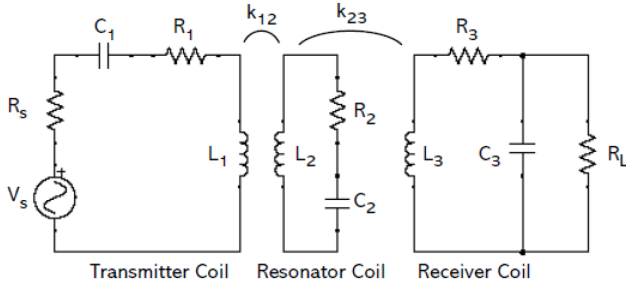

Fig. 3. Equivalent circuit model of the WPT system.

and tissues is converted by a power rectifier and a voltage regulator to produce a stable 3.3V DC output. All coils in the WPT system are connected to capacitors, which are tuned according to the resonant frequency. The collaboration of leakage inductance of coils and capacitors contributes to resonance, which eliminates the reactive impedance and maximizes the active power to the load. Besides, a supercapacitor is introduced at the output port to help initialize Bluetooth connection with higher power demands. The stability is improved considering the variations of the coupling during applications.

The implantable part as an IMD, consisting of the power receiver and sensor chip, is packaged in plastic water-proof protection. The images of the complete implantable device are presented in Fig. 2.

B. Magnetic Resonance Wireless Power Transfer

The principle of the MRC-WPT method studied in this work has been explained in this section according to the deduction in [11] and [16]. Fig. 3 shows the schematic of the 3-coil coupled

magnetic resonant WPT structure. k_{12} and k_{23} represent the mutual coupling coefficients between the transmitter coil and resonator coil, and between the resonator coil and receiver coil, respectively. The coupling between the transmitter coil and receiver coil is ignored assuming there is a larger distance between them. To compensate for the leakage inductance of coils, the system is operating at a resonance frequency $\omega = 1/\sqrt{L_1 C_1} = 1/\sqrt{L_2 C_2} = 1/\sqrt{L_3 C_3}$. Thus, the quality factors of coils can be defined by $Q_1 = \omega L_1/R_1'$, $Q_2 = \omega L_2/R_2$ and $Q_3 = \omega L_3/R_3$, where $R_1' = R_1 + R_s$. The PTE from the voltage source to the load R_L can be written as:

$$\eta_{3-coil} = \frac{(k_{12}^2 Q_1 Q_2)(k_{23}^2 Q_2 Q_{3L})}{(1 + k_{12}^2 Q_1 Q_2 + k_{23}^2 Q_2 Q_{3L})(1 + k_{23}^2 Q_2 Q_{3L})} \cdot \frac{Q_{3L}}{Q_L} \quad (1)$$

where $Q_L = R_L/\omega L_3$ and $Q_{3L} = R_p/\omega L_3$. The resistance approximated at the receiving side is given by $R_p = R_{p3} || R_L$, where $R_{p3} = Q_3^2 R_3$. In addition, the PDL of the system can be deduced as:

$$P_{3-coil} = \frac{V_s^2}{2R_1} \frac{(k_{12}^2 Q_1 Q_2)(k_{23}^2 Q_2 Q_{3L})}{(1 + k_{12}^2 Q_1 Q_2 + k_{23}^2 Q_2 Q_{3L})^2} \cdot \frac{Q_{3L}}{Q_L} \quad (2)$$

where V_s is the supply voltage. Finally, the WPT system is implemented by components specified in Table 1.

The PDL and PTE performance of the 3-coil MRC-WPT system for the in-vivo test has been demonstrated in our previous research [16]. From a distance of 8cm and through biological tissue, the wireless receiving side can provide up to 56mW power to the load (equivalent to 17mA current at 3.3V), while consuming 2.88W from the source. This outperforms the conventional 2-coil WPT system using the same transmitter and receiver coils by a factor of 1.5 at the same distance.

C. Bluetooth Module with a Temperature Sensor

The implantable sensor module is powered by the WPT module, which enables the operation of the MCU, temperature sensor, and BLE communication. The MCU is programmed by Arduino IDE and is designed to take a temperature measurement using the sensor every 5 seconds and then send the data to an external laptop via BLE. As it operates under a low-power mode and with measuring intervals, the microchip system only consumes less than 7mA on average.

In this work, we proceed to evaluate the WPT system from the perspective of practical applications. We carry out experiments using it to power up the wireless microchip sensor, so that the functional performance of the system, including temperature sensing accuracy and operational stability, can indicate the capability of the 3-coil MRC-WPT system.

III. EX-VIVO TEST

Before the in-vivo test, the ex-vivo test is first conducted. The IMD sensor is used to measure the temperature of a tank of water and the results are compared with those from a digital thermometer. This ex-vivo test can mimic an environment for the temperature sensor, where only the wireless 3-coil MRC-WPT system for power supply is available, without any wire

TABLE I
SYSTEM SPECIFICATIONS

Parameters	Symbols	Values
Transmitter Coil (L_1)		
Inductance (μH)	L_1	12.74
Resonance capacitance (nF)	C_1	60
Series resistance (Ω)	R_1	0.81
Num. of turns	n_1	6
Outer diameter (cm)	D_1	19.9
Inner diameter (cm)	d_1	18.9
Wire width (mm)	w_1	1
Resonator Coil (L_2)		
Inductance (μH)	L_2	12.56
Resonance capacitance (nF)	C_2	60
Series resistance (Ω)	R_2	0.5
Num. of turns	n_2	6
Outer diameter (cm)	D_2	20
Inner diameter (cm)	d_2	19
Wire width (mm)	w_2	1
Receiver Coil (L_3)		
Inductance (μH)	L_3	19.14
Resonance capacitance (nF)	C_3	37.73
Series resistance (Ω)	R_3	0.7
Num. of turns	n_3	36
Outer diameter (cm)	D_3	2.2
Inner diameter (cm)	d_3	1
Wire width (mm)	w_3	0.36
Overall System		
Frequency (kHz)	f	180
L_1/L_2 distance (cm)	h_{12}	2
DC input voltage (V)	V_s	24
Source Resistance (Ω)	R_s	5

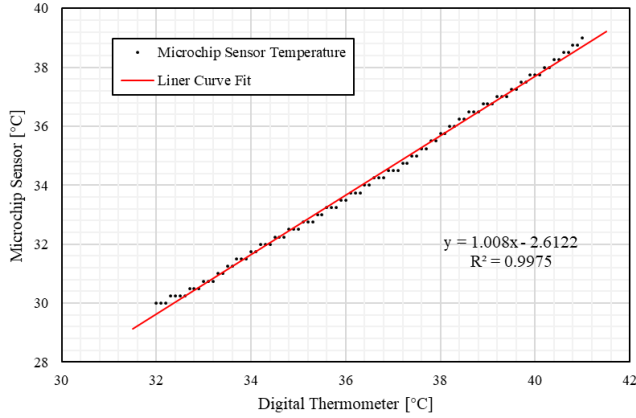

Fig. 4. Results of the ex-vivo test, digital thermometer readings versus microchip sensor readings.

connection. The tested IMD in the water-proof protector is placed in the middle of a 500mL water tank. Its power is supplied wirelessly by the transmitter from a distance of 5cm. For reference and comparison, a probe of the digital thermometer is attached to the tested device so that they can measure the temperature of the same spatial position. After completing the setup, the experiment is achieved by filling the tank with water at approximately 50°C and recording temperature values from the digital thermometer and temperature sensor on the microchip. The readings are recorded at 0.1°C intervals as the digital thermometer reading drops from 41°C to 32°C.

The measured results from the microchip temperature sensor

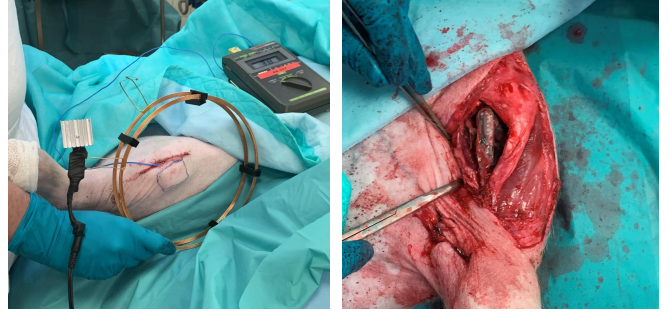

Fig. 5. In-vivo test of the WPT system to power the temperature sensor which is implanted in the leg of the pig, highlighted by the blue box. The digital thermometer probe is set in the same place as a reference.

and the respective referenced values from the digital thermometer are illustrated in Fig. 4. Based on linear curve fitting, the microchip sensor readings are linearly correlated with the reference temperature from the digital thermometer, with the coefficient of determination equal to 0.9975. While the slope of the regression curve is close to 1, some offset is observed which needs to be calibrated to improve accuracy. Besides, the resolution is limited at 0.25°C due to the characteristics of the microchip sensor itself. Thus, the one-hour ex-vivo test reveals that the microchip sensor can measure the temperature of the liquid in the tank consistently and precisely compared to the reference values. It can be concluded that the microchip sensor supplied by our 3-coil MRC-WPT system can maintain its proper measurement performance without any degradation.

IV. IN-VIVO TEST

The in-vivo test is conducted to validate the practical application of the 3-coil MRC-WPT system and its capability to support the in-body operation of the temperature sensor and the BLE communication. Similar to the ex-vivo test, the temperature sensor integrated with the microcontroller on the same chip is connected to the wireless power receiver, and they are sealed in a protector as an IMD for implantation into the long-leg bone of a pig. For in-vivo testing, surgery is performed by our clinicians to implant the device into the tibia of the pig. The sensor is placed in order under the bone, behind the muscle, behind the bone, and inside the bone. Each time the sensor is implanted at a different site, the probe of the digital thermometer is inserted at the same place and the wound is sutured. The temperature at each position is measured for 600 seconds, with the WPT transmitter set above the sensor and at a distance of 5cm away from the skin. Besides, the collected data is recorded by the laptop via BLE.

Fig. 5 presents the in-vivo test described above for in-body temperature collection. When the device is implanted in the tibia bone of the pig, the WPT system is verified to be able to supply power for the proper operation of the sensor 5cm away from the skin. The measurement results are illustrated in Fig. 6, denoting temperature values gathered by the IMD microchip sensor and the digital thermometer versus

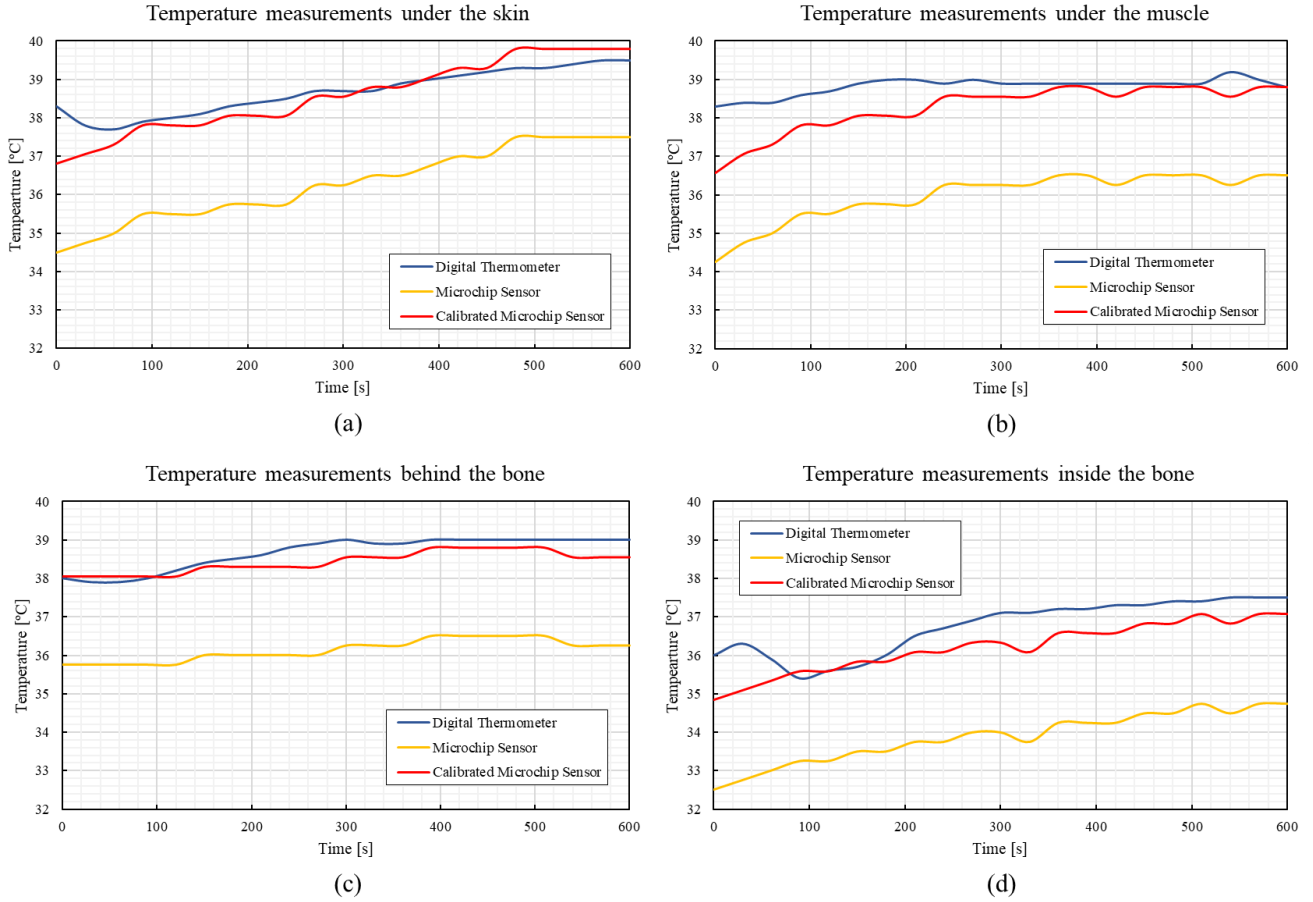

Fig. 6. Time-temperature results of the in-vivo test, measured by a digital thermometer and microchip sensor at different positions: (a) under the skin, (b) under the muscle, (c) behind the bone and (d) inside the bone.

the measurement duration at a series of positions at the pig tibia. It should be noted that the results of the microchip sensor are calibrated based on the linear curve fitting from the ex-vivo test. Both uncalibrated and calibrated temperature lines are plotted in Fig. 6 for comparison. It is apparent from all graphs that there is a considerable gap between the uncalibrated temperature measurements from the microchip sensor and the digital thermometer. But calibration can significantly minimize this gap as it eliminates the offset of the microchip sensor found through the ex-vivo test.

Most temperature profiles exhibit an increasing trend until they stabilize after around 300 to 400 seconds. This is because it should take some time for both sensors to respond to the temperature under the in-body environments. As the microchip temperature sensor is embedded inside the IC, its temperature conductivity is lower, and thus, it requires a longer time to complete the measurement as shown in these results. According to the final steady-state results (after around 400 seconds), the temperatures collected behind the muscle and behind the bone are almost constant at about 39°C. The measured temperature under the skin is slightly higher and exceeds 39.5°C. These values are close to the bladder temperature of the pig, which is 38.3°C, showing good

consistency. Furthermore, as shown in Fig. 6(d), the internal temperature of bone is approximately 37°C, which is 2°C lower than that of muscle and blood.

This in-vivo test validates the tested 3-coil MRC-WPT system can guarantee the functionality of the sensor together with the microcontroller working inside the pig near the tibia bone. The wireless microchip sensor can correctly reflect the temperature at desired places, by the comparison with reference temperature defined by the digital thermometer. Neither the implant positions nor the different implant depths affect its performance. During the 10-minute measurements, the stability of the system is approved as no error in data communication and degradation in measurement accuracy are observed. We believe the results of this experiment demonstrate the feasibility of further application of the 3-coil MRC-WPT system for implantable sensors.

V. CONCLUSION

In this paper, we present a wireless-powered IMD and its experiments with a pig for validation of the proposed 3-coil coupled magnetic resonant WPT method. This implantable sensing device for testing consists of a BLE SoC for data communication and temperature measurements and a receiver

acquiring power wirelessly from the transmitter of the WPT system. First, through the ex-vivo experiment, we verify the measuring performance of the temperature sensor of the IMD when powered by the proposed 3-coil MRC-WPT system. After that, we conduct an in-vivo experiment on a pig, during which the sensor is implanted in a series of positions near the tibia, to evaluate its wireless in-body temperature measurements. Taking the readings of a digital thermometer as a reference, the implanted sensor powered wirelessly is able to collect the desired information and send them to a laptop via BLE, with the transmitter of the WPT system placed 5cm away from the skin above the sensor.

With the ex-vivo and in-vivo experiments on the proposed WPT system, we demonstrate its driving capability to enable the implanted device to perform proper operations including accurate temperature sensing and BLE communication without the use of other stable voltage sources. The advantages of the 3-coil MRC-WPT method also come to the fore during the test. For power delivery, the operating distance of 5cm from the skin of the animal can tolerate a certain amount of mismatch and allow for flexible movements. It is essential for some animal experiments with implantable sensors where the normal activities of animals must not be restricted. Due to its high power output, the size of both the receiver coil and transmitter coil can be kept small, reducing the impacts of the implant and offering convenience and privacy when using the power transmitter. Besides, it is believed the size of the WPT system can be further minimized by integrating the power receiver with the sensor module for more versatile and secure implantation, which is an objective of our future study.

In conclusion, this study complements the lack of in-vivo experiments on the 3-coil MRC-WPT system for IMDs and validates its practical application. Future studies on implantable sensors and their related in-vivo animal experiments may benefit from the proven WPT concept.

ETHICS

This study was approved by the Inspectorate of the Animal Experimentation under the Danish Ministry of Justice. All care and well-being of the animals were carried out in accordance with the EU legislation and directives regarding animal research.

REFERENCES

- [1] K. Na, H. Jang, H. Ma, and F. Bien, "Tracking optimal efficiency of magnetic resonance wireless power transfer system for biomedical capsule endoscopy," *IEEE Transactions on Microwave Theory and Techniques*, vol. 63, no. 1, pp. 295–304, 2014.
- [2] O. Aquilina, "A brief history of cardiac pacing," *Images in paediatric cardiology*, vol. 8, no. 2, p. 17, 2006.
- [3] J. D. Weiland and M. S. Humayun, "Visual prosthesis," *Proceedings of the IEEE*, vol. 96, no. 7, pp. 1076–1084, 2008.
- [4] S. Fountain, M. Windolf, J. Henkel, A. Tavakoli, M. A. Schuetz, D. W. Huttmacher, and D. R. Epari, "Monitoring healing progression and characterizing the mechanical environment in preclinical models for bone tissue engineering," *Tissue Engineering Part B: Reviews*, vol. 22, no. 1, pp. 47–57, 2016.
- [5] B. D. Nelson, S. S. Karipott, Y. Wang, and K. G. Ong, "Wireless technologies for implantable devices," *Sensors*, vol. 20, no. 16, p. 4604, 2020.

- [6] S. R. Khan, S. K. Pavuluri, G. Cummins, and M. P. Desmulliez, "Wireless power transfer techniques for implantable medical devices: A review," *Sensors*, vol. 20, no. 12, p. 3487, 2020.
- [7] J. Zhang, R. Das, J. Zhao, N. Mirzai, J. Mercer, and H. Heidari, "Battery-free and wireless technologies for cardiovascular implantable medical devices," *Advanced Materials Technologies*, vol. 7, no. 6, p. 2101086, 2022.
- [8] D. C. Ng, C. E. Williams, P. J. Allen, S. Bai, C. S. Boyd, H. Meffin, M. E. Halpern, and E. Skafidas, "Wireless power delivery for retinal prostheses," in *2011 Annual International Conference of the IEEE Engineering in Medicine and Biology Society*. IEEE, 2011, pp. 8356–8360.
- [9] K. Ding, Y. Yu, H. Lin, and J. Xie, "Wireless power transfer at sub-gHz frequency for capsule endoscope," *Progress In Electromagnetics Research C*, vol. 66, pp. 55–61, 2016.
- [10] H.-J. Kim, H. Hirayama, S. Kim, K. J. Han, R. Zhang, and J.-W. Choi, "Review of near-field wireless power and communication for biomedical applications," *IEEE Access*, vol. 5, pp. 21 264–21 285, 2017.
- [11] M. Kiani, U.-M. Jow, and M. Ghovanloo, "Design and optimization of a 3-coil inductive link for efficient wireless power transmission," *IEEE transactions on biomedical circuits and systems*, vol. 5, no. 6, pp. 579–591, 2011.
- [12] A. Kurs, A. Karalis, R. Moffatt, J. D. Joannopoulos, P. Fisher, and M. Soljacic, "Wireless power transfer via strongly coupled magnetic resonances," *science*, vol. 317, no. 5834, pp. 83–86, 2007.
- [13] S. Y. R. Hui, W. Zhong, and C. K. Lee, "A critical review of recent progress in mid-range wireless power transfer," *IEEE Transactions on Power Electronics*, vol. 29, no. 9, pp. 4500–4511, 2013.
- [14] C.-L. Yang, C.-K. Chang, S.-Y. Lee, S.-J. Chang, and L.-Y. Chiou, "Efficient four-coil wireless power transfer for deep brain stimulation," *IEEE Transactions on Microwave Theory and Techniques*, vol. 65, no. 7, pp. 2496–2507, 2017.
- [15] S. A. Mirbozorgi, P. Yeon, and M. Ghovanloo, "Robust wireless power transmission to mm-sized free-floating distributed implants," *IEEE transactions on biomedical circuits and systems*, vol. 11, no. 3, pp. 692–702, 2017.
- [16] Q. Hua, B. K. Krøver, L. A. Rytøft, M. W. Frost, S. V. Kold, O. Rahbek, G. F. Pedersen, and M. Shen, "Wireless power transfer based on 3-coil magnetic resonance coupling for biomedical implants," in *2021 IEEE MTT-S International Wireless Symposium (IWS)*. IEEE, 2021, pp. 1–3.