

Aalborg Universitet



The effect of filter cake viscoelasticity on filtration

a study of activated sludge dewatering

Christensen, Morten Lykkegaard

Publication date:
2006

Document Version
Publisher's PDF, also known as Version of record

[Link to publication from Aalborg University](#)

Citation for published version (APA):

Christensen, M. L. (2006). *The effect of filter cake viscoelasticity on filtration: a study of activated sludge dewatering*. Aalborg Universitet.

General rights

Copyright and moral rights for the publications made accessible in the public portal are retained by the authors and/or other copyright owners and it is a condition of accessing publications that users recognise and abide by the legal requirements associated with these rights.

- Users may download and print one copy of any publication from the public portal for the purpose of private study or research.
- You may not further distribute the material or use it for any profit-making activity or commercial gain
- You may freely distribute the URL identifying the publication in the public portal -

Take down policy

If you believe that this document breaches copyright please contact us at vbn@aub.aau.dk providing details, and we will remove access to the work immediately and investigate your claim.

**THE EFFECT OF FILTER CAKE
VISCOELASTICITY ON FILTRATION
- A STUDY OF ACTIVATED SLUDGE DEWATERING**

MORTEN LYKKEGAARD CHRISTENSEN

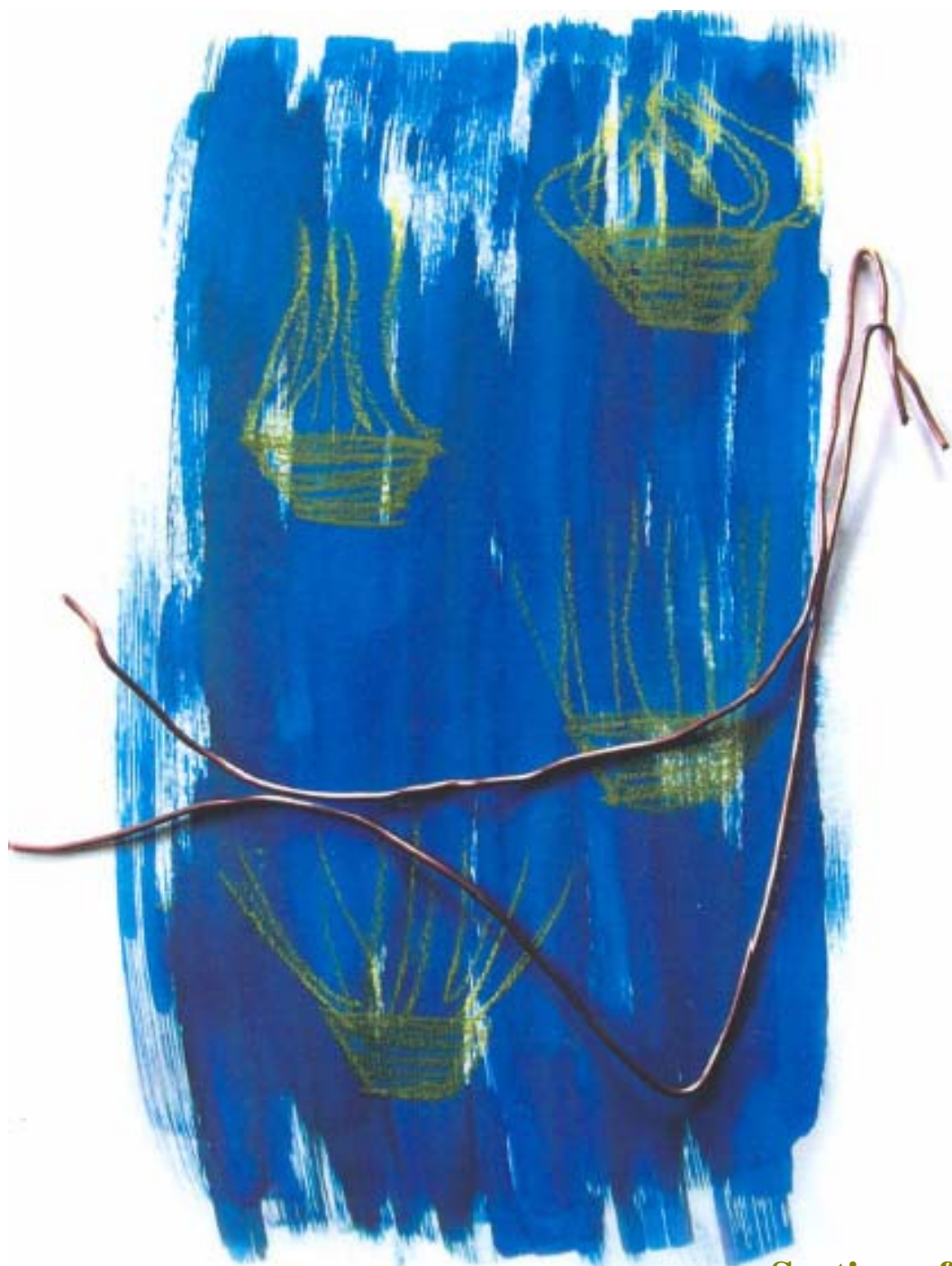

**Section of Chemistry
Aalborg University
Ph.D. Dissertation, 2006**

**THE EFFECT OF FILTER CAKE
VISCOELASTICITY ON FILTRATION
- A STUDY OF ACTIVATED SLUDGE DEWATERING**

MORTEN LYKKEGAARD CHRISTENSEN

**Section of Chemistry
Aalborg University
Ph.D. Dissertation, 2006**

Printed in Denmark by
UNIPRINT, Aalborg University, September 2006
ISBN 87-90033-44-2

Preface

This dissertation is submitted in partial fulfilment of the requirements for obtaining the degree of doctor of philosophy (Ph.D.). The dissertation consists of abstracts in English and Danish, a short thesis, and six supporting papers.

The study was carried out at the Section of Chemistry, Department of Biotechnology, Chemistry and Environmental Engineering, Aalborg University during the period from August 2001 to January 2006 and was financed by Aalborg University. Part of the work has been carried out at Chalmers University of Technology, Department of Chemical Engineering and Environmental Science (Gothenburg, Sweden). In this connection, I wish to thank Professor Hans Theliander, assistant professor Peter Sedin and Christian Johansson for supervision and technical assistance during my stay at Chalmers University. I also wish to thank my supervisor Kristian Keiding for help and guidance, as well as Søren Hvidt (Roskilde University, Denmark) for helpful discussions and suggestions. Likewise, I wish to thank, Niels Peter Raj Andersen, Lisbeth Wybrandt, Peter Vittrup Christensen, and Mogens Hinge for their encouragement, experimental assistance and many rewarding discussions. Finally, I wish to thank my wife Helle Christensen and my sons David and Simon for all their support and patience.

Aalborg, January 2006

Morten Lykkegaard Christensen

List of contents

Preface.....	1
Abstract	5
Dansk resume (Danish abstract)	7
1. Introduction.....	9
2. Objective	11
3. Existing knowledge.....	13
3.1. Filtration theory.....	13
Permeability	13
Compressibility	18
Permeability and compressibility measurements.....	20
3.2. Dead-end filtration experiments.....	22
Accumulation stage.....	22
Consolidation stage.....	25
Secondary consolidation	29
3.3. Filtration of activated sludge.....	32
4. A study of filter cake properties.....	37
4.1. Equipment and materials.....	37
4.2. The transition between accumulation and consolidation	38
4.3. Elastic model for consolidation.....	42
4.4. Viscoelastic model for consolidation.....	45
4.5. Study of activated sludge filter-cakes	48
5. Model materials for filtration studies.....	53
6. Filtration model for activated sludge	57
7. Conclusion	61
Nomenclature	63
Literature.....	67
List of supporting papers	75
Publications not included in this thesis	76

Abstract

Wastewater is usually treated biologically, and a by-product from this treatment is waste-activated sludge with high water content. It is therefore economically viable to dewater the sludge in order to reduce the volume for handling and disposal, and to minimise the water content before incineration of the sludge. However, the dewatering process is expensive, i.e. 30 – 50 % of the total operational costs for wastewater treatment are related to the dewatering process. Thus, optimisation of the dewatering process is of great interest.

A method for sludge dewatering is filtration. The key objectives in filtration dewatering are a high filtrate flux and high dry matter content in the filter cake that is formed during the filtration. Pre-treatment of the feed, such as addition of salts and/or polymers, regulation of pH, and heating, can be used to optimise the process. Furthermore, it is possible to change process parameters such as applied pressure and volume of activated sludge per filter media area. Therefore, it is important to know how these parameters influence the filtration performance. Mathematical models exist that can be used to simulate filtrations. These models have been tested on inorganic particles such as titanium dioxide, kaolin, and bentonite, and they have been used to scale up filtrations of minerals. Nevertheless, it is difficult to find similar examples where the filtration models have been used to scale-up filtrations of activated sludge. This suggests that the assumptions, made for the state-of-art models, are not being fulfilled when filtrating sludge. Thus, a study of dewatering of activated sludge has not only practical implication but also principal and theoretical implications.

The filtration performance is mainly determined by the filter cake properties, and in this study methods have been developed to investigate the properties of waste-activated sludge filter cakes. It has been shown how the average specific filter-cake resistance and the average filter-cake compressibility can be calculated during the consolidation stage from measurements of the liquid pressure at the sample-piston interface. The method has been tested on titanium dioxide and later used to study activated sludge filter cakes. Furthermore, experiments have been performed where the pressure (creep experiments) or the filter cake thickness (stress relaxation experiment) was kept constant. These experiments show that there is no unique relationship between pressure and dry matter.

In order to study this phenomenon in more detail, poly(styrene-*co*-acrylic acid) (poly(ST-*co*-AA)) latex particles have been synthesised. Poly(ST-*co*-AA) latex particles consist of a hard polystyrene core and a soft/deformable water-soluble polyacrylic acid shell. The latex particles therefore contain water, as do the sludge flocs whereas they in this perspective deviate from hard inorganic particles. Moreover, latex particles form filter cakes that creep, as does activated sludge. The retardation time due to creep deformation (Θ_3) increases with the acrylic acid content in the latex particles. Thus, it is possible to vary Θ_3 and study how such changes influence the accumulation stage, i.e. the time until the piston touches the filter cake. Pressure and dry matter profiles have been measured through such filter cakes and results indicate that the time dependent compression of the filter cake is present during the accumulation stage and not only during the consolidation stage.

When using the conventional filtration models it is usually assumed that a unique relationship between pressure and dry matter exists and the reason why it is difficult to use the existing filtration models to simulate filtrations of activating sludge may be that this assumption is incorrect. Based on the results from this study, a modified filtration model has been developed. A viscoelastic expression has been suggested for calculating the pressure profile in the filter cake, which is easily incorporated in the existing filtration models. Two new input parameters are introduced, and it is shown how stress relaxation experiments can be used to find both parameters. All other input parameters can be determined in the same way as done for the conventional filtration models. Numerical simulations show that the modified filtration model fits filtration data for waste-activated sludge, well. Furthermore, it has been shown that the model is capable of being scaled with respect to volume and dry matter concentration in the feed suspension. This is important if the model is to be used for dimensioning of sludge-dewatering plants. Moreover, it has been shown how simple, well-characterised materials can be synthesised and used to study the influence of physicochemical properties of solid particles on filter cake viscoelasticity. This knowledge can be used to improve pre-treatment and dewatering of sludge.

Dansk resume (Danish abstract)

Spildevand behandles som ofte biologisk og et restprodukt fra processen er biologisk slam med et højt vandindhold. På grund af det høje vandindhold er det rentabelt at afvande slammet inden den efterfølgende behandling, opbevaring og eventuelle afbrænding. Udgifterne til afvandingen udgør dog mellem 30 – 50 % af de samlede udgifter til spildevandsrensningen, hvilket gør det interessant at undersøge mulighederne for at optimere afvandingsprocessen.

En vigtig metode til at afvande biologisk slam er filtrering. Under filtrering er det vigtigt at opnå en hurtig afvanding samt et højt tørstofindhold i den filterkage, der dannes under filtreringen. Det er blandt andet muligt at optimere filtreringsprocessen ved at forbehandle slammet for eksempel ved tilsætning af salt, tilsætning af polymer, regulering af pH, og/eller opvarmning af slammet. Det er desuden muligt at ændre operationsparametrene for eksempel påsat tryk og slamvolumen pr. filterareal. Der findes en række filtreringsmodeller, der kan anvendes til at simulere filtreringsprocesser med henblik på at optimere disse. Filtreringsmodellerne er testet på uorganiske stoffer såsom titaniumdioxid, kaolin og bentonit, og anvendes til at opskalere filtreringer af mineraler. Det er derimod svært at finde lignende eksempler for biologisk slam. Det forhold kan skyldes, at en eller flere af de antagelser, der er foretaget i forbindelse med udledningen af de eksisterende filtreringsmodeller, ikke er opfyldt for biologisk slam.

I denne afhandling er egenskaberne af slamfilterkager undersøgt. Det er vist, hvordan det er muligt at måle filterkagemodstand og sammentrykkelighed under konsolideringen ved at introducere en tryktransducer til filtreringsudstyret samt et rør, der forbinder tryktransducere med filtreringsstempet. Metoden er testet på titaniumdioxid og senere brugt til at undersøge slamfilterkager. Der er ligeledes udført forsøg, hvor henholdsvis tryk (creep eksperimenter) og kagetykkelsen (stress relaksation eksperimenter) holdes konstant. Disse forsøg har vist, at der ikke er en entydig sammenhæng mellem tryk og tørstof. Det vil sige tørstoffet i slammet ændrer sig ikke kun som funktion af tryk men også som funktion af tid.

For at undersøge fænomenet yderligere, er der syntetiseret latexpartikler med en kerne af polystyren og en ydre skal bestående af polyakrylsyre. Polyakrylsyre skallen optager vand, hvis pH hæves og latexpartiklerne afviger dermed fra de hårde uorganiske stoffer. Derimod er der en vis lighed med

slamflokkene, der også indeholder vand og er bløde/deformerbare. Poly(styren-*co*-akrylsyre) latexpartikler danner ligesom biologisk slam filterkager der udviser tidsafhængig deformation (creep). Den karakteristiske tid for denne deformation (Θ_3) er afhængig af akrylsyreindholdet i latexpartiklerne. Ved at ændre indholdet af akrylsyre har det derfor været muligt at variere Θ_3 og undersøge hvordan dette påvirker filtreringen. Der er udført forsøg, hvor tryk- og koncentrationsprofiler er målt ned gennem filterkagen, og resultatet viser at den tidsafhængige sammenpresning af filterkagen er til stede under filtreringen og ikke kun under konsolideringen.

I de filtreringsmodeller, der normalt anvendes, antages det imidlertid, at der er en entydig sammenhæng mellem tryk og tørstof og det kan derfor tyde på, at de eksisterende filtreringsmodeller ikke er gode til at simulere filtreringsforløbet for biologisk slam, fordi denne antagelse ikke er opfyldt. Baseret på en række forsøg er der derfor udviklet en modificeret filtreringsmodel, der gør det muligt at simulere filtreringer af suspensioner. Et viskoelastisk udtryk er foreslået til at bestemme trykprofilen ned gennem filter kagen og kan let indsættes i de nuværende filtreringsmodeller. Der er introduceret to nye parameterkonstanter, og det er vist, hvordan stressrelaksationsforsøg kan anvendes til at bestemme begge konstanter. De øvrige konstanter i modellen kan bestemmes ved brug af de metoder, der anvendes, når de konventionelle filtreringsmodeller benyttes. Numeriske simuleringer viser, at det er muligt at simulere filtreringsforløbet for slam ved brug af den modificerede model. Desuden er det muligt at skalere med hensyn til tørstofkoncentrationen og/eller prøvevolumenet. Det er vigtigt, hvis modellen skal bruges i forbindelse med dimensionering af slamafvandingsanlæg. Det er desuden vist, hvordan simple velkarakteriserede materialer kan syntetiseres og anvendes til at undersøge hvordan partiklernes fysisk-kemiske egenskaber påvirker filterkagers viskoelasticitet. Denne viden kan bruges til at forbedre forbehandling og afvanding af biologisk slam.

1. Introduction

Dewatering is an important chemical unit operation and is widely used for example on wastewater treatment plants. Wastewater is usually treated biologically, and a by-product from this treatment is waste-activated sludge with high water content (95 – 99% w/w) (Winther *et al.* 2004). It is therefore economical viable to dewater sludge in order to reduce the volume before handling and disposal, and/or to minimise the water content before incineration of sludge (Dirkzwager *et al.* 1997; Sørensen and Sørensen 1997; Gurjar 2001). The dewatering process is one of the most expensive processes on wastewater treatment plants. It has been reported that 30 – 50% of the total operational costs for wastewater treatment is related to the dewatering process (Parker *et al.* 1972; Sørensen 1992). Thus, optimisation of the dewatering process is of great interest.

The dewatering process can usually be divided into three stages:

1. Pre-treatment
2. Mechanical dewatering
3. Drying

Pre-treatment includes adjustment of pH, heating, aeration, mechanical agitation, addition of coagulants (iron, aluminium or lime), and addition of flocculants (synthetic water soluble polymers) (Parker *et al.* 1972; Kang *et al.* 1990; Novak *et al.* 1999; Harbour *et al.* 2001; Chen *et al.* 2004; Neyens *et al.* 2004; Saveyn *et al.* 2005). This stage is important as it improves the performance of the following dewatering processes considerably (Wakeman and Tarleton 1999; Neyens *et al.* 2004).

Mechanical dewatering includes a range of sedimentation, centrifugation and filtration processes (Wakeman and Tarleton 1999; Gurjar 2001). Moreover, these processes can be combined i.e. sedimentation followed by filtration.

Drying is used when a product with low water content (< 40% w/w) is wanted, for example for incineration of sludge (Dirkzwager *et al.* 1997). The drying process is expensive as water is

evaporated from the solid material. Thus, low water content after the mechanical dewatering will normally lower the cost of the whole dewatering process.

Alternatively, sludge can be dewatered naturally for example by using drying beds or sludge lagoons (Gurjar 2001). The sludge dewatering is then achieved by draining and evaporation of water (Gurjar 2001).

The focus in this report is mechanical dewatering and more specifically filtration processes, where the key objectives are a fast filtration and low water content in the dewatered filter cake. The filtration time and the water content can often be lowered by changing the pre-treatment procedure i.e. the amount of salt and polymer added to the sample (Parker *et al.* 1972; Novak *et al.* 1999). It is also possible to improve the filtration process by changing the applied pressure, the amount of filter cake deposited per unit area, and the type of filter media. However, in order to do this, it is important to know how different changes influence the filtration process. This is often only possible if a range of small-scale filtration experiments has been performed, as it is difficult to predict filtration time and dry matter content directly from the physicochemical properties of the solid particles and of the liquid. The slurries that are filtrated often consist of a complex mixture of different organic and inorganic materials, whereas the filtration models, that have been developed to simulate the filtration processes, are based on filtration experiments performed on hard, low charged, inorganic particles such as titanium dioxide, kaolin, or bentonite. These conventional filtration models are suitable for scaling up the dewatering process when minerals, such as kaolin, are filtrated (Eberl *et al.* 1996). However, it is difficult to find similar examples where the filtration models have been successfully used to scale-up a filtration process where organic materials such as waste-activated sludge have been filtrated. The reason might be that it is impossible; as the assumption in the state-of-art models is not satisfied when activated sludge is filtrated.

2. Objective

The aim of this project is to improve existing filtration models in order to simulate filtrations of activated sludge as well as other slurries or suspensions with similar properties.

It is well known from literature that filter cake properties control the filtration performance (See section 3). A filtration apparatus has recently been developed in which the liquid pressure is measured at the sample-piston interface giving measurements at the top of the filter cake during the consolidation stage, where the piston touches the filter cake. The first task is to develop new methods to characterise filter cakes for example by using this additional information.

The complexity of sludge makes it difficult to study how different physicochemical properties affect the filter cake and thereby the filtration. However, such knowledge is of great value in order to optimise the sludge dewatering process and to develop filtration models. The next task is to synthesise simple, well-characterised organic compounds and use these to study how physicochemical properties of the solid particles influence the filter-cake properties. Comparison can then be made with results for sludge.

The third task is to develop a new filtration model and methods to determine the input parameters based on the above studies and a series of sludge filtrations.

3. Existing knowledge

3.1. Filtration theory

The principle of filtration is pressing a suspension towards a filter medium permeable to the liquid phase but impermeable to the solid particles. Solid particles therefore deposit on the filter medium forming a porous filter cake, and the dewatering rate is mainly determined by the *permeability* of the filter cake. The permeability is a function of the filter cake solidosity, i.e. the solid volume divided with the total volume. Further, the solidosity is a function of the effective pressure, i.e. the force acting on the particle network divided with the area perpendicular to the liquid flow (Tiller and Leu 1980). The increase of the solidosity with effective pressure has been defined as the filter cake *compressibility*. The basis for all filtration theory, as well as other forms of mechanical dewatering processes, is therefore the filter cake *permeability* and the filter cake *compressibility*. These two concepts will be described in the following two sections based on the existing filtration theory developed for hard, low charged, inorganic particles.

Permeability

The filter cake permeability (k_p) is given implicit from Darcys law as the ratio between the liquid flow (q) and the pressure gradient (dp_L/dx). The Darcys law is given as Eq. (3.1) if the system is defines as shown in Figure 3.1.

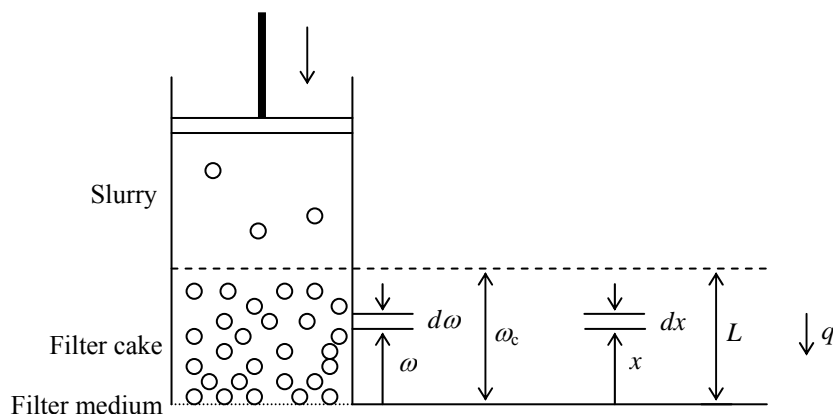

Figure 3.1: Schematic diagram of cake filtration with spatial (x) and material (ω) coordinates.

$$q = v \cdot (1 - \phi) = \frac{k_p}{\mu} \cdot \frac{dp_L}{dx} \quad (3.1)$$

The Darcys law has later been modified by introducing Lagrangian (material) coordinates (ω) instead of Eulerian (space) coordinates, and a specific filter-cake resistance (α) instead of the permeability, whereby

$$q = \frac{1}{\mu \alpha} \cdot \frac{dp_L}{d\omega} \quad (3.2)$$

and

$$d\omega = \phi \cdot \rho_s \cdot dx \quad (3.3)$$

The relationship between the permeability and the local specific filter-cake resistance can be derived by inserting Eq. (3.2) and (3.3) into Eq. (3.1), whereby

$$k_p = \frac{1}{\phi \cdot \rho_s \cdot \alpha} \quad (3.4)$$

An expression for the local specific filter-cake resistance has been derived theoretically for hard, spherical, mono-sized, non-charged particles in the dilute limit with no direct and/or indirect (i.e. hydrodynamic) interaction between the individual particles (Happel 1958). The frictional drag on each particle is then given by Stokes law if the motion of the liquid relative to the particles is slow ($Re < 0.2$), whereby Eq. (3.5) is obtained (Happel 1958).

$$q = \frac{D^2}{18 \cdot \phi \cdot \mu} \cdot \frac{dp_L}{dx} \quad (3.5)$$

Inserting Eq. (3.2) and (3.3) into (3.5) yields Eq. (3.6).

$$\alpha = \frac{18}{\rho_s \cdot D^2}, \text{ for } \phi \rightarrow 0 \quad (3.6)$$

Nevertheless, the solidosity of interest in filtration processes usually ranges from 0.2 to 0.65 where the direct and/or indirect interaction between the particles is not negligible. Thus, the actual local specific filter-cake resistance is higher than that calculated from Eq. (3.6), and a dimensionless interaction parameter, $r(\phi)$ can be introduced to correct for interaction effects.

$$\alpha = r(\phi) \cdot \frac{18}{\rho_s \cdot D^2} \quad (3.7)$$

The interaction parameter is slightly modified with respect to the interaction parameter introduced by Buscall and White (1987), and has the following properties: $r(\phi) \rightarrow 1$ for $\phi \rightarrow 0$, $dr(\phi)/d\phi > 0$, and $r(\phi) \rightarrow \infty$ for $\phi \rightarrow 1$.

In order to calculate the local specific filter-cake resistance, the relationship between the interaction parameter and the solidosity has to be known. There exist different semi-theoretical expressions for this relation (Carman 1938; Brinkman 1947; Happel 1958). The two most commonly used when modelling filtration processes will be described here shortly: 1) the Kozeny-Carman model and 2) the Happel spherical cell model.

Kozeny and Carman modelled the flow through sand-beds regarding the bed as equivalent to a bundle of circular, parallel, discrete capillary channels to which the Hagen-Poiseuilles equation can be applied (Carman 1938). This can be transformed into the following expression for the interaction parameter:

$$r(\phi) = 2 \cdot K \cdot \frac{\phi}{(1-\phi)^3} \quad (3.8)$$

where the Kozenys constant, K , has been measured to $5.0 \pm 10\%$ for spherical particles with a hydrodynamic diameter larger than $5 \mu\text{m}$ (Carman 1937). For other particle geometries K varies between 3 and 6. Yet K is not constant as function of solidosity (Coulson 1949), and the Kozeny-

Carman model does not satisfactory apply to compressible filter cake consisting of flocculated particles, where the local specific filter-cake resistance increases more rapidly than predicted (Grace 1953). In addition, the interaction parameter $r(\phi) \rightarrow 0$ and not 1 in the dilute limit.

Happel and Brenner (1965) have developed a model based on a spherical cell model and the Navier-Stokes' equation. The interaction parameter is then given in Eq. (3.9).

$$r(\phi) = \frac{6 + 4 \cdot \phi^{5/3}}{6 - 9 \cdot \phi^{1/3} + 9 \cdot \phi^{5/3} - 6 \cdot \phi^2} \quad (3.9)$$

which satisfy that $r(\phi) \rightarrow 1$ for $\phi \rightarrow 0$, $dr(\phi)/d\phi > 0$, and $r(\phi) \rightarrow \infty$ for $\phi \rightarrow 1$. The cell model agrees closely with the Kozeny-Carman model in the solidosity range from $0.3 < \phi < 0.6$ (Happel 1958; Wakeman and Tarleton 1999). Thus, the spherical cell model also underestimates the increase of the specific filter-cake resistance with solidosity for compressible filter cakes consisting of flocculated particles. Constitutive equations have therefore been used as well as the semi-theoretical expressions (Eberl *et al.* 1996; Lee and Wang 2000). One such equation is obtained by combining two constitutive equations (Tiller and Kwon 1998).

$$\alpha = \alpha_0 \cdot \phi^m \quad (3.10)$$

where m has been estimated to be 5 ± 2 (standard deviation) using data from 20 different filtration experiments (Tiller and Yeh 1987; Fathi-Najafi and Theliander 1995; Theliander and Fathi-Najafi 1996; Tiller and Kwon 1998; Teoh *et al.* 2001; Teoh *et al.* 2002).

These data are shown in Figure 3.2. It is interesting to notice the Gaussian distribution of the experimental data, although the experimental data are obtained for a broad range of different inorganic and organic compounds.

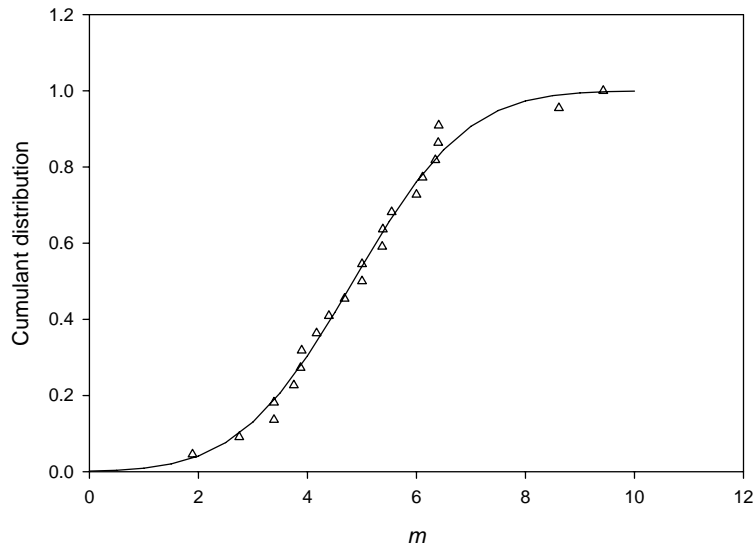

Figure 3.2: The cumulative distribution function of m calculated from 20 different filtrations (triangle). The Gaussian distribution has been fitted to the experimental data (solid line).

Other constitutive equations have been used as well (Eberl *et al.* 1996):

$$\alpha = \alpha_0 \cdot (1 - \phi)^m \quad (3.11)$$

and

$$\alpha = \frac{\alpha_0 \cdot 10^{m\phi}}{1 - \phi} \quad (3.12)$$

Thus, the specific filter-cake resistance increases with solidosity, and the filter cake compressibility is therefore also an important factor when modelling filtrations.

Compressibility

Flocculated or single particles in a suspension move freely at low solidosity, whereas the particles become interconnected and fixed in a solid-like network structure at higher solidosities. The concept of a threshold solidosity, where the particles just forms a continuous network, has therefore been introduced and denoted the gel point, ϕ_{gel} (Buscall and White 1987; Landman and White 1994). The concept has further been described and discussed in the literature (Koenders and Wakeman 1997a; Tien 2002).

The solid-like network structure can support stress elastically up to a given effective pressure, defined as the compressive yield stress $P_y(\phi)$ (Buscall and White 1987). Further, the network structure collapses irreversibly at effective pressures above $P_y(\phi)$ due to breaking and rearrangement of bounds between the particles and/or formation of more contact points between the particles (Eberl *et al.* 1996). $P_y(\phi)$ increases with solidosity. Hence, the network structure consolidate until the effective pressure equals $P_y(\phi)$. The dynamic of the compression has been given by Eq. (3.13) (Buscall and White 1987)

$$\frac{d\phi}{dt} = \begin{cases} 0 & p_s < P_y(\phi) \\ \kappa(\phi, p_s) \cdot (p_s - P_y(\phi)) & p_s \geq P_y(\phi) \end{cases} \quad (3.13)$$

where $\kappa(\phi, p_s)$ is the dynamic compressibility. Generally, it is assumed that $\kappa(\phi, p_s)$ is large, i.e. the compression of the filter cake is rate-determined by drainage of the liquid, and not by the breaking and/or reformation of interparticle bonds (Landman and White 1994). Thus,

$$p_s = P_y(\phi) \quad (3.14)$$

in filtration processes, because $dp_s/dt \geq 0$ during the whole process.

The compressive yield stress $P_y(\phi)$ is an implicit function of the strength of the interparticle bonds and the heterogeneity of the network structure (Potanin and Russel 1996; Channell *et al.* 2000). Moreover, the heterogeneity of the formed filter cake depends of the shear history of the suspension. Thus, pre-treatment procedures such as mixing and ultrasonication may influence the

filtration process (Channell *et al.* 2000). It has been shown, for example, that shear history of an α -alumina particle suspension influences $P_y(\phi)$ up to $\phi = 0.45$ (Channell *et al.* 2000).

Most of the functions relating $P_y(\phi)$ with solidosity are purely empirical, e.g. power law expressions such as Eq. (3.15) and (3.16) (Buscall and White 1987; Landman *et al.* 1995).

$$P_y(\phi) = p_a \cdot \left[\left(\frac{\phi}{\phi_{\text{gel}}} \right)^n - 1 \right] \quad (3.15)$$

and

$$P_y(\phi) = p_a \cdot \left[\left(\frac{\phi}{\phi_{\text{gel}}} \right) - 1 \right]^n \quad (3.16)$$

Auzerais *et al.* (1988) have used Eq. (3.17):

$$P_y(\phi) = p_a \cdot \left(\frac{\phi^n}{\phi_m - \phi} \right) \quad (3.17)$$

Further, Tiller and Leu (1980) used the following constitutive equation for the effective pressure as function of solidosity:

$$p_s = p_a \cdot \left[\left(\frac{\phi}{\phi_0} \right)^n - 1 \right] \quad (3.18)$$

where ϕ_0 is the solidosity at null effective pressure. Tiller and Kwon (1998) stated that Eq. (3.18) is the equilibrium relationship between effective pressure and solidosity based on the assumption of slowly changing effective pressures during the filtration i.e. the effective pressure equals $P_y(\phi)$ as in Eq. (3.14). Thus, combining Eq. (3.18) and Eq. (3.14) gives Eq. (3.15), if ϕ_0 is replaced with ϕ_{gel} . n has been regarded as a compressibility coefficient, and the coefficient has been used to divide

materials into three groups: incompressible ($n \approx 0.05$), moderately compressible ($n \approx 0.15$) and highly compressible materials ($n \approx 0.30$) (Tiller and Leu 1980).

Semi-theoretical expressions that describe the relationship between solidosity and effective pressure also exist. The effective pressure for filter cakes consisting of charged, inorganic, colloidal particles (0.1 – 10 μm) has been calculated from the number of interacting particle and analytical expressions for the two-particle interactive potential (Koenders and Wakeman 1997a; 1997b). Expressions for the two-particle interactive potential have been obtained from the DLVO theory assuming double layer repulsion as the only force acting on the particles (Koenders and Wakeman 1997a; 1997b). Thus, the potential is a function of particle size, ζ -potential, electrical double layer thickness and the distance between the particle surfaces. Furthermore, the surface distance is a function of solidosity and the electrical double layer thickness is a function the ionic strength in the suspension. The model can thereby give a more fundamental understanding of how pH, particle size, ζ -potential and ionic strength influence the compressibility. Nevertheless, the model parameters still have to be calculated from experiments.

Permeability and compressibility measurements

The input data of the conventional filtration models are the filter cake permeability and the filter cake compressibility. However, the existence of theoretical expressions for the relationship between permeability and physicochemical properties of the solid particles is limited and can neither be used for complex mixture of particles nor flocculated particles systems. Hence, the permeability normally has to be measured directly as function of solidosity. This can be done using a compression–permeability (C–P) cell, where a filter cake is compressed until a homogenous filter cake is formed (Ruth 1946; Grace 1953). Liquid is then pressed through the filter cake at lower pressure and the permeability is calculated from the filtrate flux and the applied pressure (Ruth 1946; Grace 1953). Such measurements are, however, time consuming, and several experiments are needed. Moreover, friction between the filter cake and the side-wall may influence the result (Tiller *et al.* 1972). Alternative methods have therefore been introduced. The most common method is constant pressure dead-end filtration, where an average specific filter-cake resistance is calculated from measured values of the filtrate volume (Wakeman *et al.* 1991). The average specific filter-cake resistance is defined in Eq. (3.19).

$$\alpha_{av} \equiv \frac{P_2 - P_1}{\int_{P_1}^{P_2} \alpha(p_s)^{-1} dp_s} \quad (3.19)$$

where p_1 is the effective pressure at the top of the filter cake and p_2 is the effective pressure at the bottom of the filter cake. Eq. (3.19) is identical to the definition of the average specific filter-cake resistance given in Ruth (1946) if the effective pressure at the top of the filter cake is set to zero.

In order to calculate the local specific filter-cake resistance, a constitutive equation describing its relationship with the effective pressure is needed; and simple power law or parametric functions like Eq. (3.20) and (3.21) have been widely accepted and used (Tiller *et al.* 1972; Tiller and Yeh 1987).

$$\alpha = \alpha_0 \cdot p_s^m \quad (3.20)$$

and

$$\alpha = \alpha_0 \cdot \left(1 + \frac{P_s}{P_a}\right)^m \quad (3.21)$$

The C-P method and the constant pressure dead-end filtration method have been compared showing a difference in the specific filter-cake resistance of 16% for CaCO_3 and kaolin filter cakes (Teoh *et al.* 2002).

The filter cake compressibility has been linked to the shear properties, and experiments show that the compressive yield stress has the same power-law dependency of the solidosity as the shear yield stress for alumina suspensions (Channell and Zukoski 1997). Moreover, it has been shown for inorganic particles that both the compressive yield stress and the shear yield stress reach a maximum at the isoelectric point and decrease in a parabolic manner with pH (Zhou *et al.* 2001). Although the measurement of shear experiment is faster and therefore desirable, the proportionality

factor can vary two orders in magnitude (Zhou *et al.* 2001), and it is difficult to use measurements of shear yield stress instead of measurements of compressive yield stress in order to determine the filter cake compressibility. The compressibility is therefore most accurately measured directly from filtration experiments. The compressibility is usually found by using dead-end filtrations where the filter cake is compressed until no more liquid is squeezed out of the filter cake. The dry content of the filter cake is then measured and the solidosity calculated from the solid density. The effective pressure is assumed to be uniform throughout the filter cake and equal to the applied pressure.

Both methods of determining permeability and compressibility are time consuming. Thus, stepped pressure filtration has been introduced in order to reduce the experimental time (Usher *et al.* 2001). Moreover, Sedin *et al.* (2003) have developed a filtration cell which allows the determination of filter cake compressibility and local specific filter-cake resistance by means of the simultaneous measurement of local liquid pressure and solidosity at several positions in the filter cake. It is assumed that the effective pressure equals the applied pressure minus the liquid pressure. Thus, it is possible to measure the effective pressure vs. solidosity relationship directly during the filtrations. Moreover, it is possible to calculate the local specific filter-cake resistance if the liquid flow is uniform throughout the filter cake. Still, constant pressure dead-end filtration are the most common used method for determining filter cake permeability and compressibility and the method will be described in more details in the next sections.

3.2. Dead-end filtration experiments

Dead-end filtrations are often divided into three distinct stages: an *initial stage*, an *accumulation stage* and a *consolidation stage* (Koenders and Wakeman 1996). The initial stage has been described in the literature (Koenders and Wakeman 1996; 1997b), and will not be discussed here. The accumulation and the consolidation stage are described separately in the next two sections.

Accumulation stage

The principle of the accumulation stage is shown in Figure 3.3. Liquid is pressed through a filter medium whereby solid particles accumulate on the filter medium forming a filter cake of gradually increasing thickness (Koenders and Wakeman 1996). Further, the particles in the suspension between the piston and the filter cake move freely, and the solidosity is equal to the solidosity in the

feed suspension if gravity is negligible. The particles in the filter cake, on the other hand, are fixed in a solid network structure i.e. $\phi \geq \phi_{\text{gel}}$. Hence, the liquid phase has to move relative to the solid particles in the filter cake, whereby the liquid pressure decreases and the effective pressure increases due to the frictional drag.

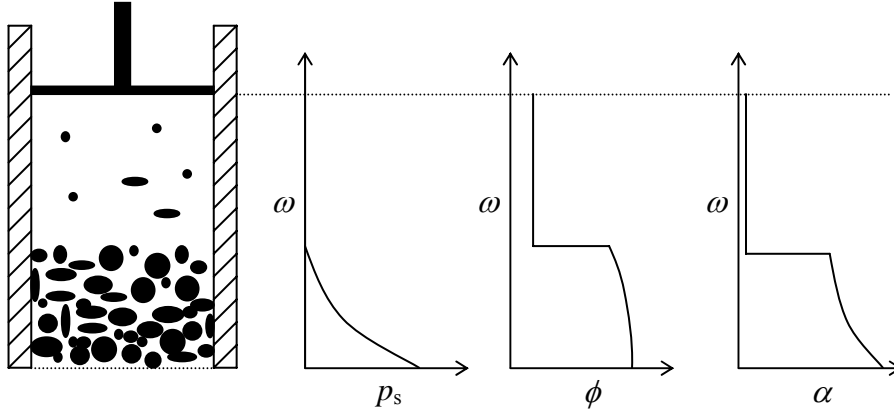

Figure 3.3: The principle of the accumulation stage

Eq. (3.22) and (3.23) shows how the effective pressure is related to the liquid pressure if the pressure loss to the cylinder and gravity are negligible.

$$P_{\text{appl}} = p_L + p_s \quad (3.22)$$

and

$$\left(\frac{dp_L}{d\omega} \right)_t + \left(\frac{dp_s}{d\omega} \right)_t = 0 \quad (3.23)$$

Hence, the effective pressure distribution through the thickness of the filter cake can be calculated from measured liquid pressures at different positions in the filtration cylinder (Wakeman 1981; Massuda *et al.* 1988; Fathi-Najafi and Theliander 1995; Sedin *et al.* 2003; Tarleton and Hadley 2003; Christensen *et al.* 2006b). Such measurements show that the effective pressure is zero at the top of the filter cake and increases down to the filter medium. Furthermore, the effective pressure at the filter medium ($p_{s,\omega=0}$) is given from the medium resistance (R_{mem}) and the filtrate flux according to the filtration theory cf. Eq. (3.24) (Sørensen *et al.* 1996).

$$p_{s,\omega=0} = P_{\text{appl}} - \mu \cdot R_{\text{mem}} \cdot \frac{dv}{dt} \quad (3.24)$$

The solidosity has been measured at different positions in the filtration cylinder using both destructive and non-destructive methods (Hutto 1957; Baird and Perry 1967; Bierck *et al.* 1988; Horsfield *et al.* 1989; Meeten 1993; Tarleton and Hancock 1996; Tarleton 1999; Sedin *et al.* 2003). A sharp change of the solidosity is usually observed across the interface between the suspension and the filter cake. It has, moreover, been shown that the solidosity of compressible filter cakes increases from the top of the filter cake to the filter medium.

The local specific filter-cake resistance also increases down through the filter cake as the solidosity increases (Sedin *et al.* 2003). Nevertheless, the average specific filter-cake resistance is often calculated instead. The average specific filter-cake resistance is defined in Eq. (3.19) and its relationship to the filtrate volume can be derived. Eq. (3.25) is obtained inserting Eq. (3.23) into Eq. (3.2) and integrating the equation using the following lower limits: $p_s = p_{s, \omega=0}$ at $\omega = 0$ and upper limits: $p_s = 0$ at $\omega = \omega_c$.

$$\int_0^{\omega_c} q d\omega = \int_0^{p_{s,\omega=0}} \frac{1}{\mu \alpha} dp_s \quad (3.25)$$

Inserting Eq. (3.19) and (3.24) into Eq. (3.25) gives Eq. (3.26) if it is assumed that q is constant throughout the filter cake.

$$\frac{dv}{dt} = \frac{P_{\text{appl}}}{\mu \cdot \alpha_{\text{av}} \cdot \omega_c + \mu \cdot R_{\text{mem}}} \quad (3.26)$$

The filter cake thickness (ω_c) changes during the accumulation stage and it are usually assumed that the filter cake thickness increases proportional with the filtrate volume:

$$\omega_c = c \cdot v \quad (3.27)$$

where c can be calculated by using Eq. (3.28) (Wakeman *et al.* 1991).

$$c = \frac{\rho_L \cdot s}{1 - Ms} \quad (3.28)$$

c is almost equal to the solid concentration in the feed suspension for dilute suspensions.

It is now possible to insert Eq. (3.27) into Eq. (3.28) and integrate the equation. This way Eq. (3.29) is obtained if the lower limits are set to zero and it is assumed that the average specific filter-cake resistance is constant during the accumulation stage.

$$\frac{t}{v} = \alpha_{av} \cdot \frac{\mu \cdot c}{2 \cdot P_{appl}} \cdot v + \frac{\mu \cdot R_{mem}}{P_{appl}} \quad (3.29)$$

Moreover, Eq. (3.30) can be derived if the filter media resistance is low compared to the filter-cake resistance.

$$v = \sqrt{\frac{2 \cdot P_{appl}}{\alpha_{av} \cdot c \cdot \mu}} \cdot \sqrt{t} \quad (3.30)$$

Hence, the filtrate volume increases linearly with the squared filtration time. The average specific filter-cake resistance can therefore be calculated from filtrate volume vs. time data. Moreover, the relationship between average specific filter-cake resistance and pressure can be measured by repeating the filtration experiments at different applied pressures, whereby it is possible to estimate the empirical parameters in Eq. (3.20) or (3.21) by using Eq. (3.19).

Consolidation stage

The filtration experiment enters the *consolidation stage* when the piston touches the filter cake (Koenders and Wakeman 1996). Moreover, the accumulation stage and the consolidation stage are often analysed separately, as the consolidation stage differs from the accumulation stage in many

aspects. No dry matter is added to the filter cake and the filter cake thickness decreases due to the compression. Furthermore, a gradually increasing part of the applied pressure is transferred directly to the filter cake (Christensen *et al.* 2006a). Thus, the effective pressure at the top of the filter cake increases, whereby the solidosity and specific filter-cake resistance increase as well (Figure 3.4). The effective pressure at the filter cake/filter medium interface is equal to the applied pressure if the medium resistance is negligible. Hence, the effective pressure, the solidosity and the specific filter-cake resistance distribution through the thickness of the filter cake change during the consolidation stage, whereby the average filter-cake resistance increases.

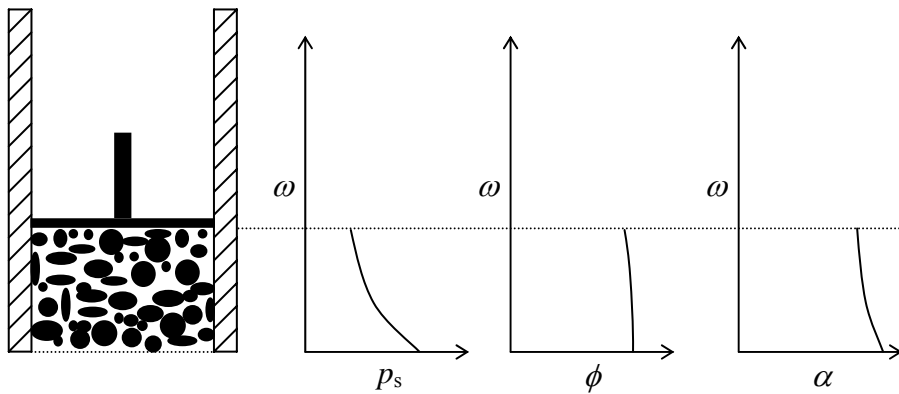

Figure 3.4: The principle of the consolidation stage

It is necessary to identify the transition between the accumulation and the consolidation stage in order to analyse the consolidation stage. A common method is to measure the filtrate volume as function of time and identify the point where the linearity between filtrate volume and square root time ceases. There are different ways of doing this (Tarleton and Wakeman 1999).

Terzaghi and Peck (1948) have developed a model that describe the consolidation of soils assuming that all voids are filled with water, there is no interchange of water between solid and liquid, and d'Arcys law is strictly valid. The consolidation model has later been used to analyse the consolidation stage in filtration experiments (Shirato *et al.* 1970). Terzaghis consolidation model can be derived from Eq. (3.2) and Eq. (3.31a) where Eq. (3.31a) is the mass balance for the liquid in the filter cake.

$$\frac{dq}{d(\omega/\rho_s)} = \frac{de}{dt_c} \quad (3.31a)$$

where the void ratio (e) can be calculated from the solidosity by using Eq. (3.31b).

$$e = \frac{1 - \phi}{\phi} \quad (3.31b)$$

Eq. (3.32) is obtained by inserting Eq. (3.31b) into Eq. (3.31a).

$$\frac{dq}{d\omega} = -\frac{1}{\rho_s \cdot \phi^2} \cdot \frac{d\phi}{dt_c} \quad (3.32)$$

Further, Eq. (3.33) can be derived from Eq. (3.32) by using the chain rule.

$$\frac{dq}{d\omega} = -\frac{a_v}{\rho_s} \cdot \frac{dp_s}{dt_c} \quad (3.33)$$

where a_v is the coefficient of compressibility and defined in Eq. (3.34) .

$$a_v \equiv -\frac{de}{dp_s} = \frac{1}{\phi^2} \cdot \frac{d\phi}{dp_s} \quad (3.34)$$

The Terzaghi consolidation equation can now be derived by differentiating Eq. (3.2) with respect to ω , and inserting Eq. (3.23) and Eq. (3.33). It is assumed that the specific filter-cake resistance in Eq. (3.2) is constant.

$$\frac{dp_s}{dt_c} = C_e \cdot \rho_s^2 \frac{d^2 p_s}{d\omega^2} \quad (3.35)$$

where C_e is the consolidation coefficient defined in Eq. (3.36).

$$C_e \equiv \frac{\phi \cdot k_p}{\mu \cdot a_v} = \frac{1}{\mu \cdot a_v \cdot \alpha \cdot \rho_s} \quad (3.36)$$

The consolidation coefficient has been denoted the moisture diffusivity or filtration diffusivity as the Terzaghi consolidation equation has the form of a diffusion equation from a mathematical point of view (Smiles 1970; Sherwood 1993; Landman *et al.* 1999). The consolidation coefficient is simply the ratio between the filter-cake permeability and the coefficient of compressibility; and a measure of how quickly equilibrium is achieved during the consolidation. A high consolidation coefficient indicates a rapid consolidation.

It has been assumed that the consolidation coefficient is constant, as it is difficult to solve the Terzaghi consolidation equation analytically if the consolidation coefficient varies with pressure (Shirato *et al.* 1970). Moreover, the boundary conditions and the initial effective pressure profile through the thickness of the filter cake have to be known in order to solve the Terzaghi consolidation equation. The boundary conditions in Eq. (3.37) to (3.39) have often been used as well as a uniform initial effective pressure distribution throughout the filter cake (Shirato *et al.* 1986).

$$0 \leq t_c \leq \infty \text{ and } \omega = \omega_c, \frac{\partial p_s}{\partial \omega} = 0 \quad (3.37)$$

$$0 \leq t_c \leq \infty \text{ and } \omega = 0, p_s = P_{\text{appl}} \quad (3.38)$$

$$t_c = \infty \text{ and } 0 \leq \omega \leq \omega_c, p_s = P_{\text{appl}} \quad (3.39)$$

The Terzaghi consolidation equation can now be solved and Eq. (3.40) obtained (Terzaghi and Peck 1948).

$$U \equiv \frac{v_c}{v_\infty} = 1 - \frac{8}{\pi^2} \sum_{N=0}^{\infty} \left[\frac{1}{(2N+1)^2} \cdot \exp\left(-\frac{(2N+1)^2 \cdot \pi^2 \cdot \rho_s^2}{4 \cdot \omega_c^2} \cdot t_c\right) \right] \quad (3.40)$$

Sivaram and Swamee (1997) later modified this solution by making an empirical approximation that fits the exact solution to within 3%:

$$U = \frac{\left[\frac{4}{\pi} \cdot \frac{C_e \cdot \rho_s^2}{\omega_c^2} \cdot t_c \right]^{0.5}}{\left(1 - \left[\frac{4}{\pi} \cdot \frac{C_e \cdot \rho_s^2}{\omega_c^2} \cdot t_c \right]^{2.8} \right)^{0.179}} \quad (3.41)$$

The denominator is approximately equal to 1 for $U \leq 0.5$. Thus, the filtrate volume increases linearly with the square root of time during the initial part of the consolidation stage.

In the above equation it has been assumed that the initial effective pressure is uniform throughout the filter cake. Nevertheless, this is not the case when consolidation succeeds an accumulation stage. Thus, other solutions have been devised. One such is given in Shirato *et al.* (1970), who have found that the initial effective pressure distribution through the thickness of the filter cake can be approximated by a sinusoidal curve for moderately compressible filter cakes. Using the boundary conditions in Eq. (3.37) to (3.39) and an initial sinusoidal effective pressure distribution gives Eq. (3.42) when the Terzaghi consolidation model is solved analytically (Shirato *et al.* 1986).

$$U = 1 - \exp\left(-\frac{\pi^2 \cdot \rho_s^2 \cdot C_e}{\omega_c^2} \cdot t_c\right) \quad (3.42)$$

This equation has also been used for highly compressible materials such as lignin (Sedin 2003). However, poor agreement between the measured and the assumed initial effective pressure distribution has been observed (Sedin 2003). Thus, it is not possible to derive an equation that can be used for all types of materials and the compressibility of the material has to be known in order to make the correct choice.

Secondary consolidation

The Terzaghi consolidation model does not always give a satisfying description of the experimental data (Shirato *et al.* 1974; Wakeman and Tarleton 1999). A proper explanation of such deviations could be that the local solidosity in the filter cakes depends not only upon the local effective

pressure but also on time. Models exist that can be used to describe the consolidation of such filter cakes (Shirato *et al.* 1974; Sherwood *et al.* 1991; LaHeij *et al.* 1996a; Kamst *et al.* 1997b; 1997a). Shirato *et al.* (1974) and (1986) for example have modified the Terzaghi consolidation model by dividing the consolidation into two stages: *primary* and *secondary consolidation*. Primary consolidation is dominated by dissipation of pore water and collapse of the filter cake global structure. Secondary consolidation is dominated by creep, which is a result of the relative movements of individual particles into a more stable configuration (Mesri 1973; Chang and Lee 1998). The mass balance for the liquid has been written as Eq. (3.43) instead of Eq. (3.32)

$$\frac{dq}{d\omega} = -\frac{1}{\rho_s \cdot \phi^2} \cdot \left(\frac{d\phi}{dp_s} \right)_{t_c} \cdot \left(\frac{dp_s}{dt_c} \right)_{\omega} - \frac{1}{\rho_s \cdot \phi^2} \cdot \left(\frac{d\phi}{dt_c} \right)_{p_s} \quad (3.43)$$

where the first term on the left hand side represents the primary consolidation controlled by hydrodynamic effects, while the second term represents the secondary consolidation controlled by creep deformation.

Inserting Eq. (3.34) into Eq. (3.43) gives Eq. (3.44).

$$\frac{dq}{d\omega} = -\frac{a_v}{\rho_s} \frac{dp_s}{dt_c} - \frac{1}{\rho_s \cdot \phi^2} \cdot \left(\frac{d\phi}{dt_c} \right)_{p_s} \quad (3.44)$$

The time-dependent deformation of the filter cake has been describe mathematically by using the mechanical analogy shown in Figure 3.5 (Shirato *et al.* 1974).

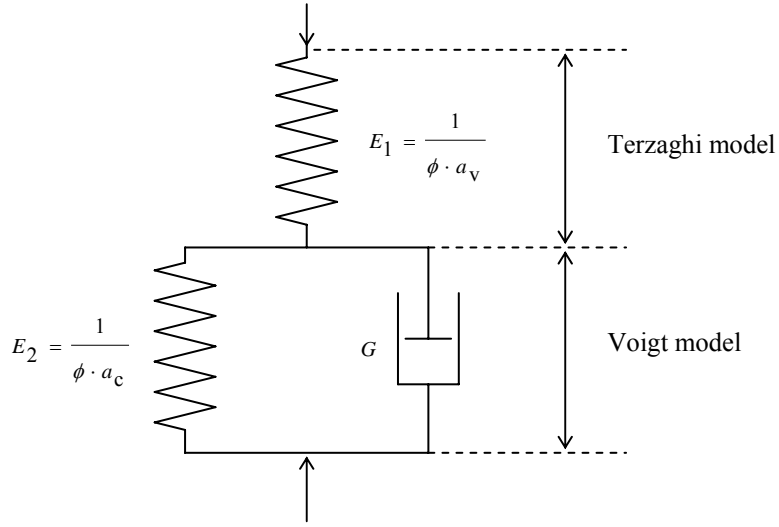

Figure 3.5: The Terzaghi-Voigt combined model for consolidation.

The primary consolidation is modelled as a spring, and the elastic coefficient of the spring (E_1) is related to the coefficient of compressibility for primary consolidation (a_v) as shown in Figure 3.5. This approach is similar to that used in the Terzaghi consolidation model for the whole consolidation stage. The secondary consolidation is modelled by a so called Voigt element, which is a spring and a dashpot in parallel. The relationship between the elastic coefficient for the Voigt element (E_2) and the coefficient of compressibility for secondary consolidation (a_c) is given in Figure 3.5

The second term on the left hand side of Eq. (3.44) is then given as Eq. (3.45) (Shirato *et al.* 1974).

$$\frac{1}{\rho_s \cdot \phi^2} \cdot \left(\frac{d\phi}{dt_c} \right)_{p_s} = \frac{1}{\rho_s} \frac{d}{dt_c} \int_0^{t_c} a_c \left(1 - \exp \left[-\frac{E_2}{G} \cdot (t_c - \tau_d) \right] \right) \frac{dp_s}{d\tau_d} d\tau_d \quad (3.45)$$

Assuming that a_v , a_c and E_2/G are constants, differentiating Eq. (3.2) with respect to ω and inserting (3.23), (3.44) and Eq. (3.45) gives Eq. (3.46) (Shirato *et al.* 1974).

$$\frac{dp_s}{dt_c} + \frac{a_c}{a_v} \cdot \frac{E_2}{G} \cdot \frac{d}{dt_c} \int_0^{t_c} (p_s - p_{s,t_c=0}) \cdot \exp \left[-\frac{E_2}{G} \cdot (t_c - \tau_d) \right] d\tau_d = C_e \cdot \rho_s^2 \frac{d^2 p_s}{d\omega^2} \quad (3.46)$$

Eq. (3.46) has been solved using the boundary conditions in Eq. (3.37) – (3.39), and an initial sinusoidal effective pressure distribution through the thickness of the filter cake (Shirato *et al.* 1974). The result is given as Eq. (3.47) if the time rate of secondary consolidation is much smaller than the time rate of the primary consolidation.

$$U = (1 - B) \cdot \left[1 - \exp\left(-\frac{t_c}{\Theta_1}\right) \right] + B \cdot \left[1 - \exp\left(-\frac{t_c}{\Theta_3}\right) \right] \quad (3.47)$$

where $B \equiv a_c/(a_v + a_c)$, $\Theta_3 \equiv G/E_2$, and Θ_1 is defined in Eq. (3.48).

$$\Theta_1 \equiv \frac{4 \cdot \omega_c^2}{\pi^2 \cdot \rho_s^2 \cdot C_e} \quad (3.48)$$

Furthermore, Eq. (3.49) is obtained if the initial effective pressure is uniform throughout the filter cake, and the Sivaram and Swamee approximation is used (Shirato *et al.* 1974; Sivaram and Swamee 1977).

$$U = (1 - B) \cdot \frac{\left(\frac{16 \cdot t_c}{\Theta_1 \cdot \pi^3}\right)^{0.5}}{\left[1 + \left(\frac{16 \cdot t_c}{\Theta_1 \cdot \pi^3}\right)^{2.8}\right]^{0.179}} + B \cdot \left[1 - \exp\left(-\frac{t_c}{\Theta_3}\right) \right] \quad (3.49)$$

3.3. Filtration of activated sludge

The development of the described filtration theory has been based on filtration of inorganic particles, and the theory has later been transferred to filtration of activated sludge. However, several features make activated sludge different from inorganic particles (Chang and Lee 1998). Activated sludge consists of primary particles (0.5 – 5 μm) and sludge flocs (25 – 200 μm) (Snidaro *et al.* 1997; Mikkelsen 1999), where the flocs consist of a complex mixture of bacteria, organic and inorganic particles, and extracellular polymeric substances (EPS) (Palmgren 1996). The flocs are

highly porous having a fractal-like interior structure with water gabs of various size inside the flocs (Li and Ganczarczyk 1990; Snidaro *et al.* 1997). Large amount of water is bound chemically or physically to the surfaces, physicochemically adsorbed due to the osmotic effects of counter ions, and/or trapped inside crevices and interstitial spaces (Mikkelsen and Keiding 2002; Vaxelaire and Cezac 2004). Furthermore, the properties of sludge change over time due to chemical and microbial processes (Nielsen *et al.* 1996).

It is not well documented how these features affect the dewatering process, but several differences between inorganic particles and activated sludge have been reported. The average specific filter-cake resistance for sludge filter cakes is usually high compared to the resistance found for filter cakes of inorganic particles (Tiller and Kwon 1998; Mikkelsen and Keiding 2002). Storage of sludge often increases the average specific filter-cake resistance (Rasmussen *et al.* 1994; Nielsen *et al.* 1996). Moreover, measurements of the solidosity distribution through the filter cake when filtrating iron/lime conditioned sludge have not shown a sharp discontinuity between the solidosity in the suspension and the solidosity in the filter cake as usually observed when filtrating inorganic particle suspensions (LaHeij *et al.* 1996b). Further, sludge forms highly compressible filter cakes in contrast to inorganic particles that form moderately compressible or incompressible filter cakes (Tiller and Kwon 1998). Mathematical simulations have shown that highly compressible filter cakes form a thin skin layer on the top of the media, which is only a few percent of the whole filter cake thickness (Sørensen and Hansen 1993). Most of the pressure drop happens in this thin skin layer and the filtrate flow is almost independent of filtration pressure (Sørensen and Hansen 1993). A filtration study of activated sludge has shown that the filtrate flow becomes constant above an applied pressure of 0.02 bar (Sørensen and Sørensen 1997), and it has been suggested that the filterability is quantified by a specific filtrate flow rate (SFF) instead of the average specific filter-cake resistance (Sørensen *et al.* 1996). In addition, mathematical simulations of the filtration process have shown that the average specific filter-cake resistance calculated from Eq. (3.29) or (3.30) is underestimated for highly compressible filter cakes, because the assumption of a constant superficial liquid flow resistance through out the thickness of the filter cake is incorrect (Shirato *et al.* 1969; Tiller *et al.* 1999; Lee *et al.* 2000a).

Filtration studies have shown that the filtrate volume measured during the accumulation stage does not always increase linearly with the square root of time (Notebaert *et al.* 1975). An explanation

may be that not all solid particles in the sludge are deposited at the top of the filter cake, but some of the fine particle clog the free flow paths in the filter cake and/or the filter media (blinding) (Notebaert *et al.* 1975). The so-called blinding theory has been supported by measurements of turbidity in the filtrate, which decreases during the filtration process. This indicates that an increasing amount of fine particles is caught in the filter cake as the filter cake grows (Sørensen *et al.* 1995). Thus, the average specific filter-cake resistance increases during the accumulation stage because the pores in the filter cake are blocked by small particles, which results in a non-linear dependency between filtrate volume and the square root of filtration time. Some attempts have been made to develop mathematical models that describe the blinding process; most of these are purely empirical (Notebaert *et al.* 1975; Tiller *et al.* 1981; Sørensen *et al.* 1995; Sørensen *et al.* 1997; Tien *et al.* 1997).

A study of the consolidation stage has shown two transition points when filtrating conditioned activated sludge, whereas only one transition point has been observed when filtrating inorganic particle suspensions (Chang and Lee 1998). The consolidation stage for sludge filter cakes has therefore been divided into three distinct stages instead of two stages as done when deriving the Terzaghi-Voigt combined model (Chang and Lee 1998). These three stages are

1. *Primary consolidation*

Dissipation of pore water and collapse of the filter cake global structure.

2. *Secondary consolidation*

Particle migration into a more stable stage, which requires the particles to overcome the shear stress introduced by highly viscous surface absorbed water between the particles.

3. *Tertiary consolidation*

Deformation and compression of individual particles accompanied with erosion of bound water.

It has been described how different pre-treatment procedures influence the filterability of sludge (Kang *et al.* 1990; Rasmussen *et al.* 1994; Chang *et al.* 1997; Novak *et al.* 1999; Chen *et al.* 2004; Saveyn *et al.* 2005). Moreover, different types of sludge have been characterised and the data has

been correlated with the average specific filter-cake resistance and the compressibility (Kang *et al.* 1989; Houghton and Stephenson 2002; Mikkelsen and Keiding 2002). It is, however, difficult to use filtration experiments with activated sludge to develop a link between the physicochemical properties of the feed suspension and the filtration result as sludge is a complex mixture of different components (Ormeçi and Vesilind 2000). Furthermore, the composition varies from plant to plant and changes over time due to aging (Ormeçi and Vesilind 2000; Nielsen 2002). Hence, the dewatering mechanism for activated sludge is not well understood and it is still difficult to predict the performance of sludge filtrations. Model materials with properties similar to them found for activated sludge have therefore been used in order to improve the understanding of the dewatering mechanism (Legrand *et al.* 1998; Ormeçi and Vesilind 2000). Legrand *et al.* (1998) have synthesised anionic hydrogel particles and afterwards filtrated the particles suspensions with varying amount of added salt (LaCl_3) and cationic polyelectrolytes. The result was compared to experiments where sludge was used. Both the sludge and the synthetic hydrogel particles flocculate when the number of positive charges from La^{3+} equals the number negative charge in the sludge or gel network; or when the number of charge from high molecular weight polycations equals 10% of the negative charge in the sludge or gel network. However, the synthetic hydrogel deswells when adding salt and polycations, whereas the sludge does not. Sanin and Vesilind (1996) and (1999) created synthetic chemical sludge flocs by mixing polystyrene latex particles, alginate and calcium ions. Polystyrene latex particles were used to simulated individual bacteria, alginate was used to simulate EPS and calcium ions were used as the bridging ions. Later, cellulose fibres have been added to the mixture to simulate filamentous micro-organisms (Ormeçi and Vesilind 2000). It was found that the average specific filter-cake resistance of the chemical sludge was similar to that found for activated sludge. Moreover, it was investigated how addition of cationic polyelectrolyte influence the specific filter-cake resistance (Sanin and Vesilind 1996; 1999).

4. A study of filter cake properties

The filtration performance is mainly determined by the filter cake properties as already described in section 3. Thus, it is important to have methods for measuring the filter cake properties when developing new filtration models. One such method is to consolidate the filter cake while measuring the deformation, and afterwards analyse the consolidation data (See section 3.3). In order to do this, it is necessary to determine the transition between the accumulation and the consolidation stage. This is usually done by identifying the point in time where the linearity between filtration volume and square root time ceases (See section 3.2). However, filtrations of sludge show that the filtrate volume measured during the accumulation stage does not always increase linearly with square root time (See section 3.3). Thus, a new method has been developed to identify the transition point. Moreover, the methods, used to obtain and analyse the consolidation data, have been further developed in order to avoid some of the needed assumptions and to improve the obtained results. Both the elastic (Terzaghi) and the viscoelastic (Terzaghi-Voigt) models have been tested and used to study the behaviour of activated sludge filter cakes.

4.1. Equipment and materials

Figure 4.1 shows a sketch of the filtration apparatus used for most of the experiments in this study.

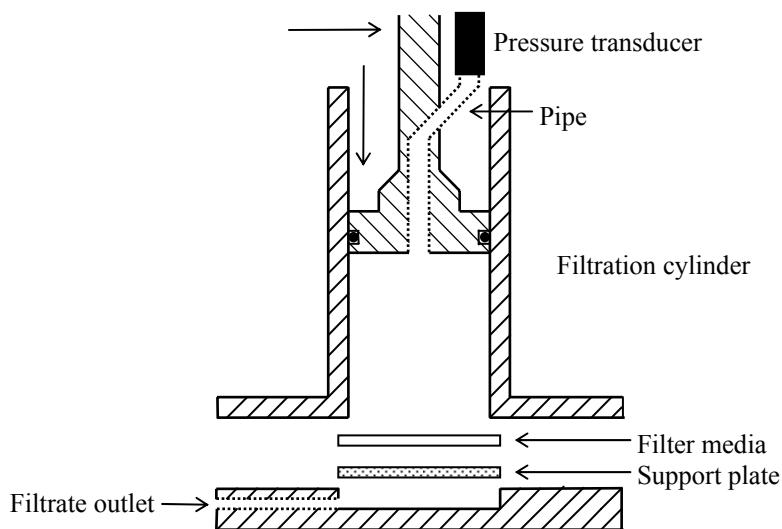

Figure 4.1: Filtration/Expression cell with liquid pressure transducer.

Filtrations are carried out by placing the filtration cell (cylinder, media and piston) in a controlled deformation apparatus. A constant pressure is then applied to the piston while measuring the liquid pressure at the sample-piston interface and the piston position. The apparatus is called a “filtration/expression cell with liquid pressure sensor” and has been described in more details in Sørensen and Hansen (1993) and Novak *et al.* (1999). Some experiments have been performed by using a further modified apparatus, where a membrane transducer (Danfoss MBS 4010, Denmark) has been placed at the centre of the piston in level with the piston head so it is possible to measure the pressure transferred directly from the piston to the sample (piston pressure, p_{Piston}). The piston pressure has been kept constant during these experiments.

Three different materials have been used for the studies: 1) titanium dioxide (anatase) particles as a model material for testing the elastic model, 2) poly(styrene-co-acrylic acid) (poly(ST-co-AA)) latex particles as a model material testing the viscoelastic model, and 3) activated sludge. The experimental details for titanium dioxide particles are found in Andersen *et al.* (2004), for poly(ST-co-AA) latex particles in Christensen *et al.* (2006b), and for activated sludge in Christensen and Keiding (2006a) and (2006b).

4.2. The transition between accumulation and consolidation

A new method has been developed to identify the transition between the accumulation and the consolidation stage. By definition, the filtration process enters the consolidation stage when the piston touches the filter cake, where after a gradually increasing part of the piston pressure is transferred directly to the filter cake structure (See section 3.2). Thus, the liquid pressure at the sample-piston interface starts to decrease at the transition between the accumulation and the consolidation stage, and measurements of the liquid pressure can be used to determine the transition point. Figure 4.2 and Figure 4.3 show the result from an experiment where titanium dioxide particles have been filtrated. The liquid pressure starts to decrease after approximately 0.9 h or after approximately 22 mL filtrate has been squeezed out. Furthermore, for a broad range of compounds it has been shown that the liquid pressure starts to decrease before the linearity between filtrate volume and square root time ceases (Christensen *et al.* 2006a). Thus, application of liquid pressure measurement is the most accurate method for identifying the transition point.

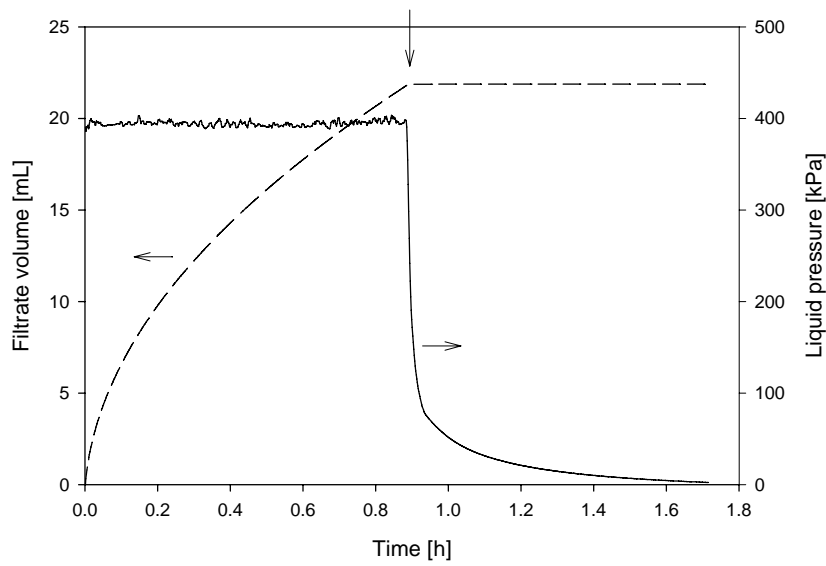

Figure 4.2: Filtration of titanium dioxide particles with an applied pressure of 4 bar (pH 9.2). The vertical arrow indicates the transition between the accumulation stage and the consolidation stage. Additional information about the experiment is given in Christensen *et al.* (2006).

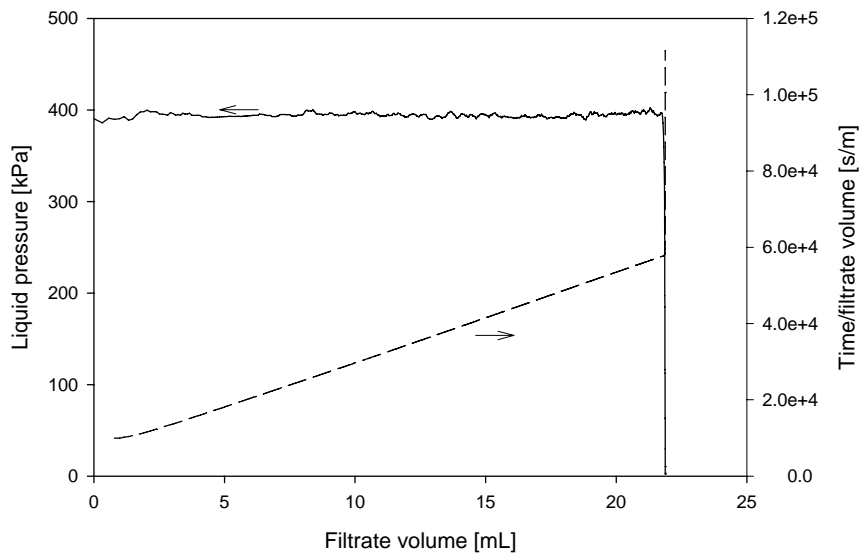

Figure 4.3: The time/filtrate volume (dashed line) and liquid pressure (solid line) are shown as function of the filtrate volume. Data from Figure 4.2 has been used.

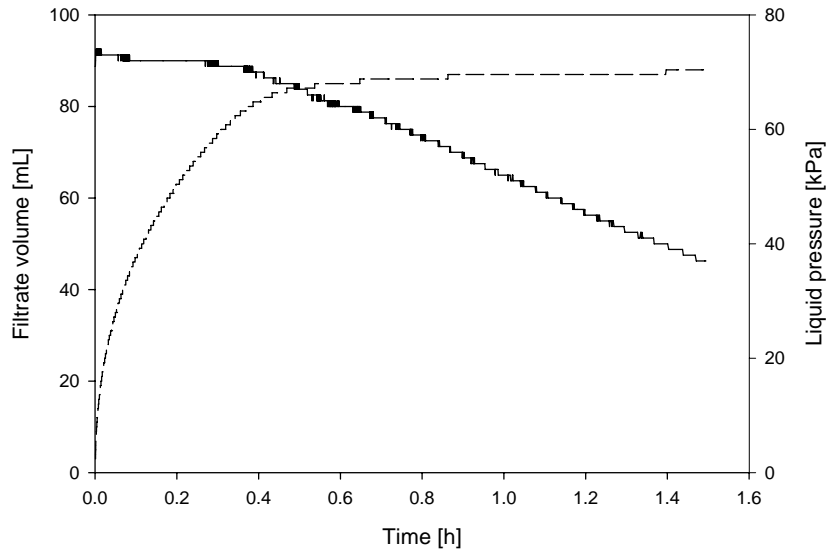

Figure 4.4: Filtration of 8.1 g/L activated sludge with an applied pressure of 1 bar at 20 °C, pH 7 and conductivity around 1.0 mS/cm.

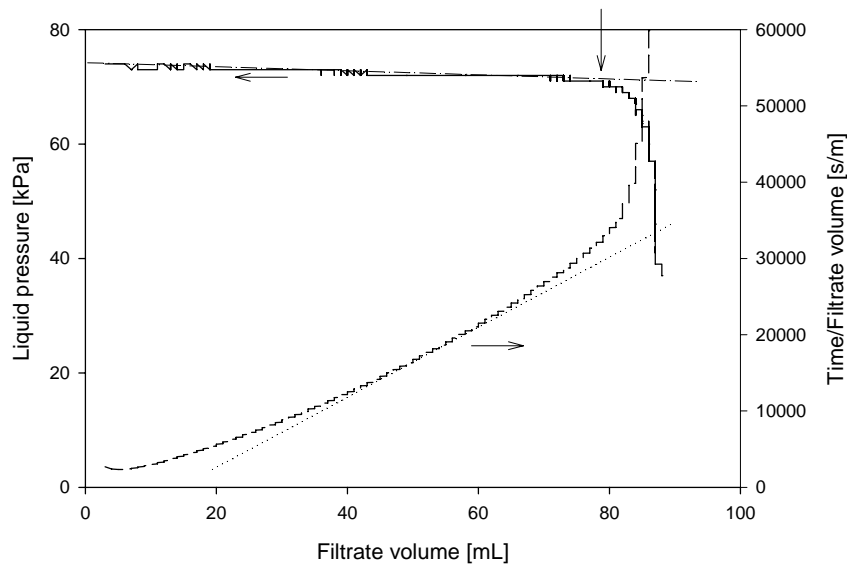

Figure 4.5: The time/filtrate volume (dashed line) and liquid pressure (solid line) are shown as function of the filtrate volume. Data from Figure 4.4 has been used. The vertical arrow indicates the transition between the accumulation stage and the consolidation stage. A dotted line has been added to illustrate the non-linear relationship between filtrate volume and time/filtrate volume. Furthermore, a dashed-dotted line has been added and used to determine the transition point.

Figure 4.4 and Figure 4.5 show similar results from an experiment with activated sludge. It is seen from Figure 4.5 that time/filtrate volume increases non-linearly with filtrate volume during the whole filtration. Moreover, the liquid pressure decreases slightly during the first part of the experiment and starts to drop rapidly after approximately 80 mL filtrate has been squeezed out. Thus, it has been concluded that 80 mL filtrate has been squeezed out at the transition between the accumulation and consolidation stage, and the slightly decreasing liquid pressure during the accumulation stage has been ascribed to friction between the piston and filtration cylinder.

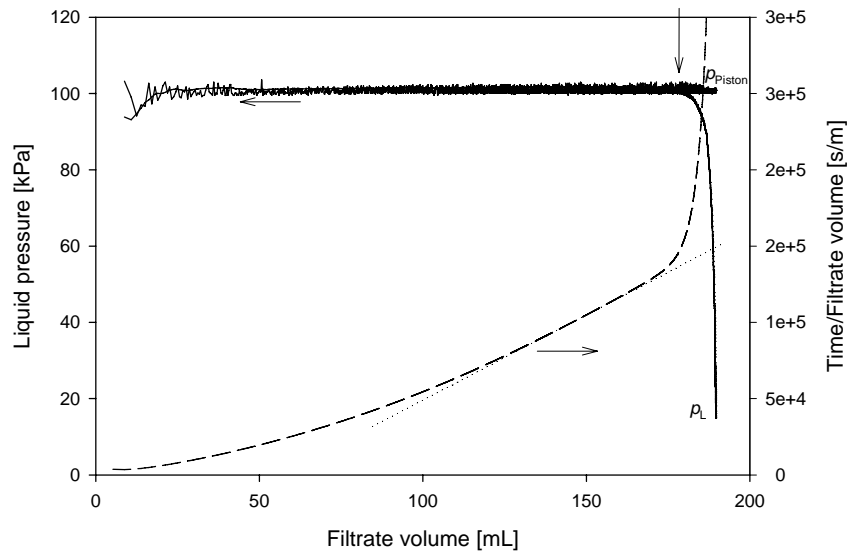

Figure 4.6: Filtration of 11 g/L activated sludge with a piston pressure of 1 bar. The time/filtrate volume (dashed line), liquid pressure (solid line), and the piston pressure (solid line) are shown as function of the filtrate volume. The vertical arrow indicates the transition between the accumulation stage and the consolidation stage. A dotted line has been added to illustrate the non-linear relationship between filtrate volume and time/filtrate volume.

To further improve the method and avoid the problem with friction between the filtration cylinder and the piston, a filtration apparatus has been built in which it is possible to measure the pressure that is transferred directly from the piston to the sample (piston pressure). Figure 4.6 shows the results from an experiment where activated sludge has been filtrated by using the modified filtration apparatus. Again, the time/filtrate volume increases non-linearly with filtrate volume during the filtration. Moreover, it is seen that the liquid pressure measured at the sample-piston interface equals the piston pressure during the initial part of the filtration but decreases after 175 mL filtrate has been squeezed out. The transition between the accumulation stage and the consolidation stage

can then easily be determined by identifying the point in time where the liquid pressure starts to deviate from the piston pressure.

4.3. Elastic model for consolidation

Titanium dioxide particles have been filtrated and the result analysed in order to study the elastic model for the consolidation stage. Figure 4.7 shows the degree of consolidation as function of time for one such experiment. The Terzaghi consolidation model fits the experimental data well. Thus, the filter cake does not creep or creep deformation only constitute a minor part of the consolidation

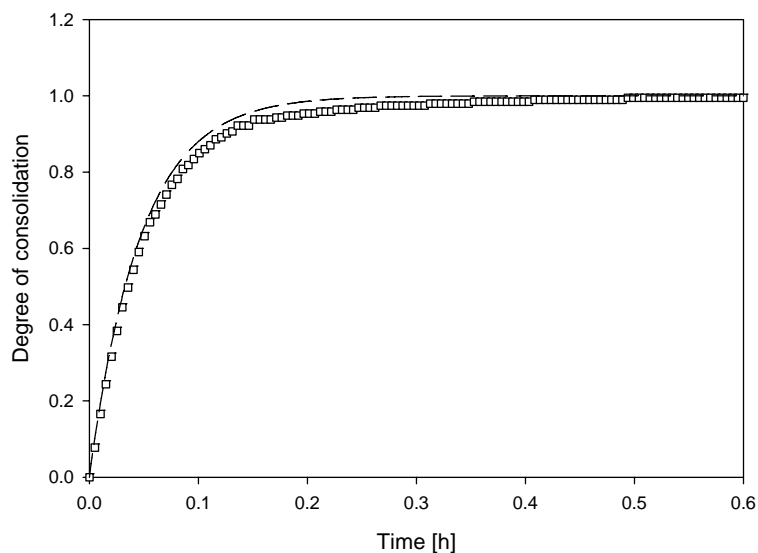

Figure 4.7: Filtration of titanium oxide particles at 2 bar (pH 7.1). The transition between the accumulation and consolidation stage has been determined and the consolidation data analysed. Terzaghi consolidation model (Eq. 3.41) has been fitted to the experimental data (dashed line). C_e calculated to be $2.4 \cdot 10^{-8} \text{ m}^2/\text{s}$. See further details in Christensen and Keiding (2006b).

Another method has been used in which the consolidation coefficient is calculated from the average specific filter-cake resistance as well as the coefficient of compressibility by using the definition of the consolidation coefficient in Eq. (3.36). The average specific filter-cake resistance during the accumulation stage has been calculated by using the measurements of filtrate volume (cf. section 3.2). Furthermore, the coefficient of compressibility has been obtained by measuring the solidosity as function of effective pressure, fitting one of the compressive yield stress functions to the experimental data (Eq. (3.15) – (3.17)), and afterwards inserting the compressible yield function

and Eq. (3.14) into Eq. (3.34). Eq. (4.1), for example, is obtained by inserting Eq. (3.14) and (3.15) into Eq. (3.34).

$$a_v = \frac{\phi_{\text{gel}}^n}{n \cdot p_a \cdot \phi^{n+1}} \quad (4.1)$$

where p_a , ϕ_{gel} and n can be estimated by fitting Eq. (3.15) to measured values of solidosity and effective pressure.

The method has been used to calculate the consolidation coefficient for titanium dioxide particles filtrated at different pH and pressures (Andersen *et al.* 2004). It has been shown the calculated consolidation coefficients are in the same order of magnitude as the consolidation coefficients that have been found using the Terzaghi consolidation model to analyse the data (Andersen *et al.* 2004). Furthermore, the method is to prefer for thin filter cakes where the filtrate volume squeezed out during the consolidation stage is low.

A weakness of the above-mentioned methods is the assumption of a constant average specific filter-cake resistance and compressibility during the whole consolidation stage. A method has been developed in order to avoid this problem, and to ensure a known initial effective pressure distribution through the thickness of the filter cake (Christensen and Keiding 2006b). The suspension is filtrated and the filter cake compressed until the measured liquid pressure at the sample-piston interface is lower than 5% of the applied pressure. It can then be assumed that the effective structure stress distribution throughout the filter cake is uniform and equal to the applied pressure cf. Eq. (3.22). The applied pressure is now stepped up to a new pressure level. This initiates the consolidation and the initial effective pressure distribution is uniform throughout the filter cake if the time that is needed to increase the applied pressure to the new pressure level is low compared to the duration of the consolidation. This condition can easily be controlled. Thus, the error due to a varying consolidation coefficient can be minimised using a stepped-pressure filtration experiment (Christensen and Keiding 2006b). However, it is difficult to measure the consolidation coefficient at low pressures.

Finally, it has been shown how it is possible to measure the average specific filter-cake resistance and the average filter-cake compressibility directly during the consolidation stage. This has been done from measurements of the filtrate volume and the liquid pressure at the sample – piston interface. The liquid pressure at the top of the filter cake (p_{L,ω_c}) is known when the liquid pressure at the sample – piston interface is measured as the piston touches the filter cake. It is therefore possible to solve Eq. (3.25) by inserting Eq. (3.19) and (3.22) whereby Eq. (4.2) is obtained (Christensen *et al.* 2006a).

$$\alpha_{av} = \frac{P_{L,\omega_c}}{\mu \cdot J_R \cdot \frac{dv}{dt} \cdot \omega_c} \quad (4.2)$$

where J_R is the correction factor defined by Shirato *et al.* (1969):

$$J_R = \int_0^1 \frac{q}{dv/dt} d(\omega/\omega_c) \quad (4.3)$$

J_R is equal to 1 when the velocity of the solid particles is zero and the superficial liquid velocity is uniform throughout the filter cake. However, the linear velocity of the solid particles at the upper part of the filter cake is close to the linear velocity of the liquid phase during the consolidation stage whereby $q < dv/dt$. Thus, J_R is lower than 1, and a lower bound for J_R has been estimated to be 0.56 (Lee *et al.* 2000b). A minimum value of the average specific filter-cake resistance can therefore be calculated using Eq. (4.2) and setting $J_R = 1$ while a maximum value can be calculated using the same equation and setting $J_R = 0.56$.

Moreover, it is possible to calculate the average coefficient of compressibility ($a_{v,av}$) by using Eq. (4.4) (Christensen *et al.* 2006a).

$$a_{v,av} = \frac{d\left(\frac{1-\phi_{av}}{\phi_{av}}\right)}{d(P_{appl} - p_{L,\omega_c})} = \frac{\rho_s}{\omega_c} \frac{dv}{d(P_{appl} - p_{L,\omega_c})} \quad (4.4)$$

It has been found that the average specific filter-cake resistance increases and the filter-cake compressibility decreases during the consolidation stage when filtrating titanium dioxide particles (Christensen *et al.* 2006a). This is expected as the locale specific filter cake resistance increases when the filter cake is compressed and the solidosity increases (See Eq. 3.10 – 3.12). Moreover, the local coefficient of compressibility decreases with the solidosity (See Eq. 4.1) and therefore the average coefficient of compressibility will also decrease.

4.4. Viscoelastic model for consolidation

Poly(ST-*co*-AA) latex particles with 7% w/w acrylic acid have been filtrated in order to study the viscoelastic model.

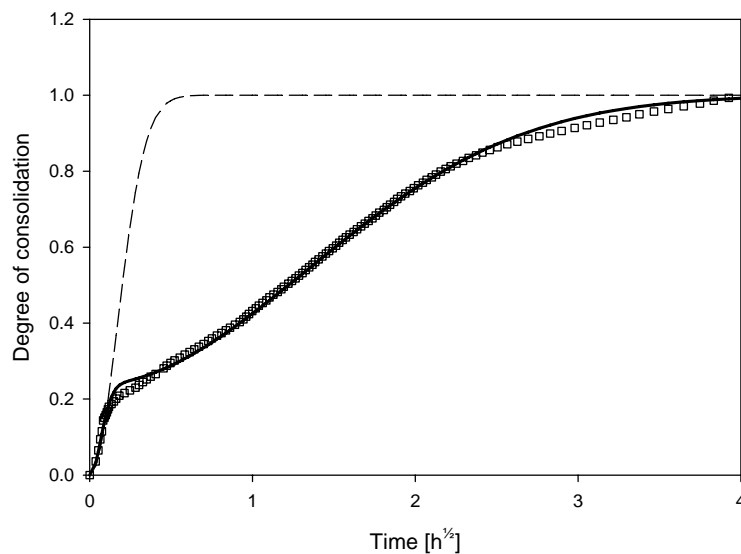

Figure 4.8: Filtration of poly(ST-*co*-AA) latex particles at 4 bar (Hinge 2005). Notice that the degree of consolidation has been plotted as function of square root time. The transition between the accumulation and consolidation stage has been determined and the consolidation data analysed. Terzaghi consolidation model (Eq. 3.41, dashed line) and Terzaghi-Voigt combined model (Eq. 3.49, solid line) have been fitted to the experimental data. C_e calculated to be $3.4 \cdot 10^{-9} \text{ m}^2/\text{s}$, Θ_3 to be 3.5 h, and B to be 0.75.

Figure 4.8 shows consolidation data for such an experiment. The Terzaghi consolidation model fits the experimental data up to $U = 0.2$ whereas the Terzaghi-Voigt combined model fits the whole

consolidation. Thus, the experimental data confirms that poly(ST-co-AA) latex particles form filter cakes that creep.

Figure 4.9 shows liquid pressures measured at the top of the filter cake. The liquid pressure decreased from P_{appl} to zero during the primary consolidation while it was almost zero during the secondary consolidation. This result supports the theory that the compression is rate-determined by drainage of the liquid during the primary consolidation but not during the secondary consolidation and it is possible to use the liquid pressure measurements to evaluate the estimated values for B (Christensen and Keiding 2006b).

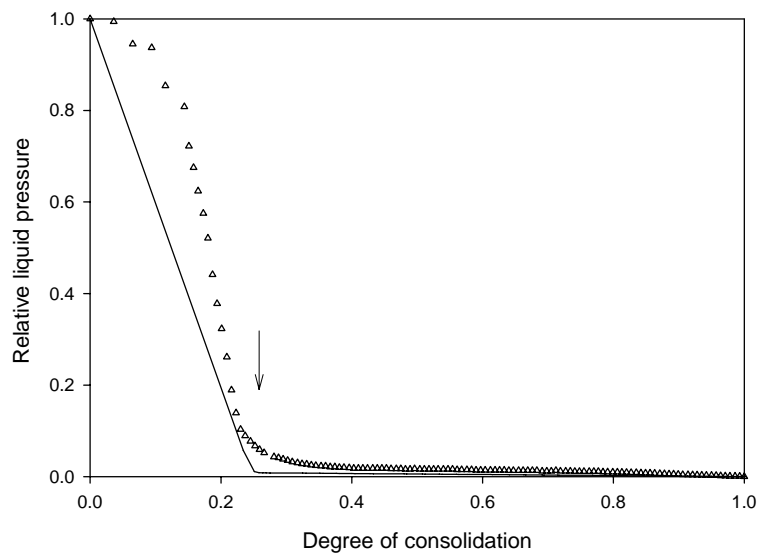

Figure 4.9: The ratio between the measured liquid pressure and the liquid pressure measured during the accumulation stage (relative liquid pressure) as function of the degree of consolidation for the filtration experiment shown in Figure 4.8. Eq. (4.5a) - (4.5e) have been used to fit the relative liquid pressure by inserting the consolidation data found when fitting the Terzaghi-Voigt combined model to the data in Figure 4.8.

Moreover, it has been shown how to calculate the liquid pressure at the top of the filter cake by inserting the found values for B , Θ_1 , and Θ_3 into Eq. (4.5a) – (4.5e). These equations have been derived from the work of Shirato *et al.* (1986) and Chang and Lee (1998).

$$p_{L,\omega_c} = P_{\text{piston}} \cdot (D_{11} \cdot \exp(\lambda_{11} \cdot t_c) + D_{21} \cdot \exp(\lambda_{21} \cdot t_c)) \quad (4.5a)$$

where

$$\lambda_{11} = \frac{1}{2} \cdot \left(\left[\Theta_3^{-1} + \frac{B}{1+B} \cdot \Theta_3^{-1} + \Theta_1^{-1} \right] + \sqrt{\left[\Theta_3^{-1} + \frac{B}{1+B} \cdot \Theta_3^{-1} + \Theta_1^{-1} \right] - 4 \cdot \Theta_1^{-1} \cdot \Theta_3^{-1}} \right) \quad (4.5b)$$

and

$$\lambda_{21} = \frac{1}{2} \cdot \left(\left[\Theta_3^{-1} + \frac{B}{1+B} \cdot \Theta_3^{-1} + \Theta_1^{-1} \right] - \sqrt{\left[\Theta_3^{-1} + \frac{B}{1+B} \cdot \Theta_3^{-1} + \Theta_1^{-1} \right] - 4 \cdot \Theta_1^{-1} \cdot \Theta_3^{-1}} \right) \quad (4.5c)$$

Furthermore,

$$D_{11} = \frac{\Theta_1^{-1} \cdot (\lambda_{11} - \Theta_3^{-1})^2}{\lambda_{11} \cdot (\lambda_{11} - \Theta_3^{-1})^2 + \frac{B}{1+B} \cdot \Theta_3^{-2}} \quad (4.5d)$$

and

$$D_{21} = \frac{\Theta_1^{-1} \cdot (\lambda_{21} - \Theta_3^{-1})^2}{\lambda_{21} \cdot (\lambda_{21} - \Theta_3^{-1})^2 + \frac{B}{1+B} \cdot \Theta_3^{-2}} \quad (4.5e)$$

The piston pressure equals the measured liquid pressure at the sample-piston interface during the accumulation stage. Moreover, Θ_1 can be calculated by using Eq. (3.48).

The liquid pressure at the top of the filter cake has been calculated and is shown in Figure 4.9. The calculated liquid pressures equals zero during the secondary consolidation as does the measured liquid pressures. Nevertheless, the calculations show that the liquid pressure decreases linearly during the primary consolidation, whereas the experimental data show a non-linear decrease. The deviation between the calculated and experimental data arises because the assumption of a constant coefficient of compressibility for primary consolidation is incorrect. Such a non-linear decrease of the liquid pressure during the primary consolidation has also been observed when filtrating titanium dioxide suspensions and activated sludge (Christensen and Keiding 2006b).

It is possible to further test the Terzaghi-Voigt combined model and evaluate the obtained parameters by varying the filter cake thickness because Θ_1 is a linear function of the squared filter cake thickness whereas B and Θ_3 are independent of the filter cake thickness according to the theory (Christensen and Keiding 2006b). Moreover, stepped-pressure filtrations can be used to ensure a known uniform initial effective pressure distribution throughout the filter cake (Christensen and Keiding 2006b).

4.5. Study of activated sludge filter-cakes

A series of sludge filtrations have been performed to study the behaviour of sludge filter cakes.

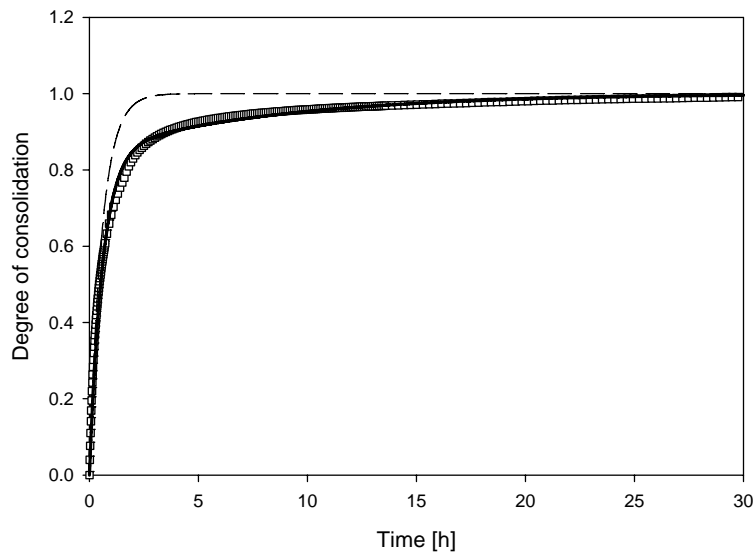

Figure 4.10: Filtration of activated sludge at 2 bar. Consolidation of anatase filter cake at 2 bar. Terzaghi consolidation model (Eq. 3.41, dashed line) and Terzaghi–Voigt combined model (Eq. (3.49, solid line) are fitted to the experimental data. C_e calculated to be $2.5 \cdot 10^{-10} \text{ m}^2/\text{s}$, Θ_3 to 8 h, and B to 0.15. Further details are found in Christensen and Keiding (2006b).

Figure 4.10 shows an experiment where the consolidation stage succeeded the accumulation stage i.e. not a stepped-pressure experiment. The Terzaghi consolidation model does not fit the consolidation data whereas the Terzaghi-Voigt combined model does. However the transition between primary and secondary consolidation is not as clear as for the filtration of poly(ST-co-AA) latex particles, neither when using the plot of degree of consolidation vs. time nor the plot of liquid

pressure vs. degree of consolidation. Hence stepped-pressure filtrations have been used instead and the thickness of the sludge filter cake varied in order to evaluate the estimated values.

A stepped pressure experiment is shown in Figure 4.11. Again Terzaghi consolidation model does not fit the consolidation data whereas the Terzaghi-Voigt combined model does. More than 50% of the compression is due to creep deformation when consolidating activated sludge filter cakes (Christensen and Keiding 2006b), as also shown in another study (Chu and Lee 1999). Moreover, it has been shown that the retardation time due to liquid flow resistance increased linearly with the squared filter cake thickness, whereas no systematic change in the retardation time due to creep deformation was observed (Christensen and Keiding 2006b). This result is consistent with the theory.

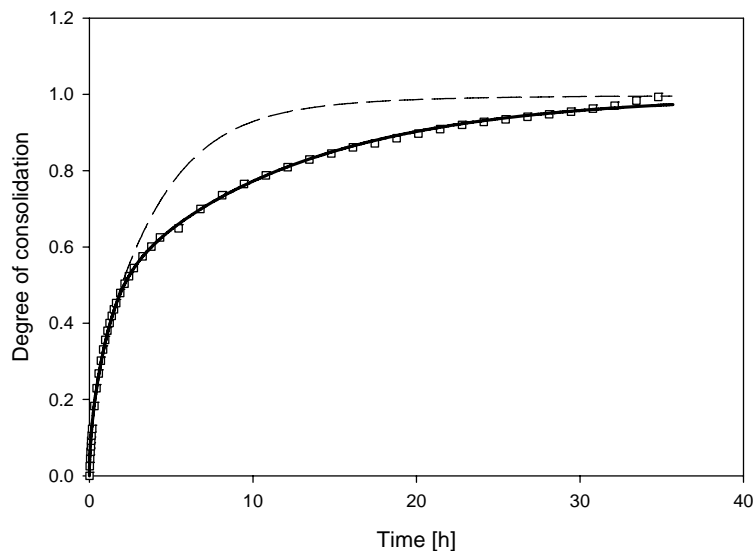

Figure 4.11: Filtration of activated sludge. The applied pressure was increased from 1 to 2 bar after 45 h. Consolidation of sludge at 2 bar. Terzaghi consolidation model (Eq. 3.42, dashed line) and Terzaghi–Voigt combined model (Eq. 3.47, solid line) are fitted to the experimental data. C_e calculated to be $1.1 \cdot 10^{-10} \text{ m}^2/\text{s}$, Θ_3 to 812 h, and B to 0.53. Further details are found in Christensen and Keiding (2006b).

The liquid pressure at the sample-piston interface increased during the first five hours after a pressure step or until the transition between primary and secondary consolidation (Christensen and Keiding 2006b). This indicated that the primary consolidation was rate-determined by drainage of the liquid, but it also showed that the filter cake crept during the primary consolidation.

Moreover, creep deformation will also influence the filtration process when the process is rate-determined by drainage of the liquid, as the specific filter-cake resistance is a function of the solids concentration. Thus, the often-observed non-linear relationship between filtrate volume and square root time when filtering activated sludge may be a result of a time-dependent deformation of the filter cake. The retardation time due to creep deformation is in the same order of magnitude as the duration of the accumulation stage. Furthermore, the filter cake is highly compressible. Both these observations indicate that creep deformation of the filter cake can influence the accumulation stage when filtering activated sludge.

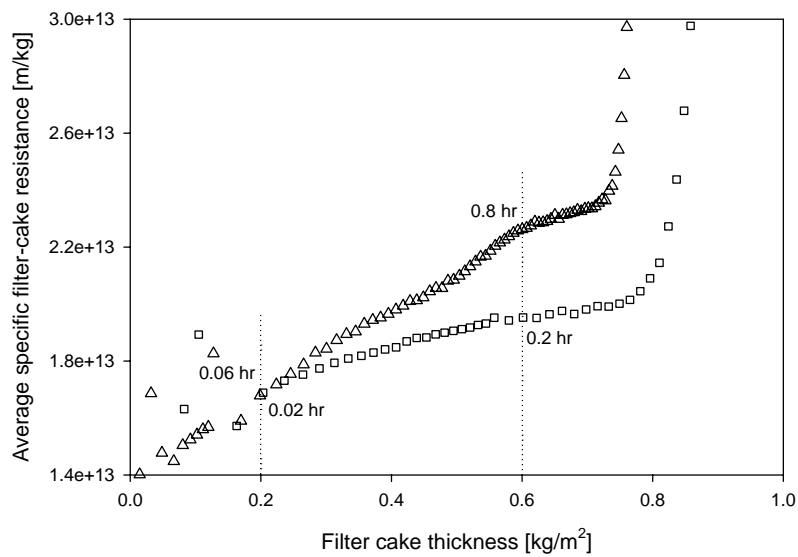

Figure 4.12: The average specific filter-cake resistance when filtering 92 mL 16 g/L activated sludge (squares) and 193 mL 7.3 g/L activated sludge (triangles). The time needed to reach the filter cake thickness $\omega_c = 0.2 \text{ kg/m}^2$ as well as $\omega_c = 0.6 \text{ kg/m}^2$ is shown for both experiments. The results are obtained from Christensen and Keiding (2005a).

Two filtrations have been performed in order to study whether creep effects influence the accumulation stage when filtering activated sludge. The total mass of dry matter was similar in the two feed suspensions, whereas the dry matter concentration and the sample volume was varied. It was thereby possible to vary the time necessary to build up the filter cake. The filter cake thickness was calculated using Eq. (3.27) and the average specific filter-cake resistance was calculated using Eq. (3.26) and neglecting the medium resistance. The result is shown in Figure 4.12. It is observed that the slope of $\alpha_{av}(\omega)$ is higher for the diluted suspension, where the filter cake grew slowly, than for the non-diluted suspension.

Thus, it has been concluded that activated sludge filter cakes creep and it is expected that creep deformation of activated sludge filter cake influence the accumulation stage as well as the consolidation stage.

5. Model materials for filtration studies

Activated sludge is a complex mixture of different compounds and it is difficult to use sludge in order to study filter-cake creep in more details i.e. to study the mechanism of the time-dependent filter-cake deformation and to investigate whether it influences the accumulation stage. An alternative is to use a model material, and in this study the following criteria have been set up for such a model material:

1. The model material has to be well characterised with regards to size, size distribution, charge density, water uptake and functional groups.
2. The model material has to form filter cakes that creep.
3. It must be possible to change specific physicochemical properties.
4. The suspension must only consist of one type of particles

Thus, the chemical sludge flocs created by Sanin and Vesilind (1996) and (1999) are too complex for this study. Moreover, the size distribution of the particles that have been used by Legrand *et al.* (1998) is too broad. Hence, others candidates are needed. An interesting group of model compounds is monodisperse colloidal latex particles prepared by free-radical surfactant-free emulsion polymerisation (Saunders and Vincent 1999). A range of different vinyl monomers can be used to prepare latex particles whereby it is possible to vary the physicochemical properties of the latex particles (Saunders and Vincent 1999). Two types of latex particles have been synthesised and studied. These are:

1. Poly(NIPAM-*co*-AA) latex particles consisting of *N*-isopropylacrylamide (NIPAM), acrylic acid (AA), and *N,N'*-methylenebisacrylamide monomers.
2. Poly(ST-*co*-AA) latex particles consisting of styrene (ST) and acrylic acid monomers.

Poly(NIPAM-*co*-AA) latex particles are aqueous gel particles and the degree of swelling depends on temperature, pH, and ionic strength (Christensen and Keiding 2004). Poly(NIPAM-*co*-AA) latex particles are soft particles with a high content of water, and it has been shown that poly(NIPAM-*co*-AA) latex particles are block copolymers with acrylic acid-rich clusters (Christensen and Keiding

2004). 0.8 μm poly(NIPAM-*co*-AA) latex particles¹ have been filtrated and the average specific filter-cake resistance calculated to be $1 \cdot 10^{16}$ m/kg whereas it for 0.3 μm titanium dioxide (anatase) particles² has been calculated to be $8 \cdot 10^{12}$ m/kg (Andersen *et al.* 2003). This shows that the specific filter-cake resistance for poly(NIPAM-*co*-AA) latex particles was three orders of magnitude higher than for titanium dioxide particles. Hence, the particle size is not the only important material parameter influencing the average specific filter-cake resistance. Nevertheless, filtrations of poly(NIPAM-*co*-AA) latex particles are time consuming filtrations.

Another candidate is poly(ST-*co*-AA) latex particles. These latex particles consist of a water insoluble polystyrene core and a water soluble polyacrylic acid shell (Pelton 2000). The average specific filter-cake resistance increases with the acrylic acid content (Hinge 2005; Christensen *et al.* 2006b). Moreover, filter cakes that consist of latex particles with an acrylic acid content $> 6.5\%$ w/w have been consolidated, and it has been shown that approximately 70% of the compression is due to creep deformation (Hinge 2005). The retardation time due to creep deformation has been calculated for the consolidation experiments and it has been observed that the retardation times increase with that acrylic acid content (Hinge 2005). Thus, it is possible to control the retardation time by changing the acrylic acid content in the latex particles. The main problem is that the solidosity change caused by creep deformation decreases when the retardation time decreases (Figure 5.1). Thus, it is difficult to measure any effects for filter cakes with low retardation times. Still, poly(ST-*co*-AA) latex particles with an acrylic content $< 5\%$ w/w have been synthesised and studied. The estimated retardation time of the formed filter cake for these latex particles is in the same order of magnitude as the duration of the accumulation stage. No creep deformation has been observed during the consolidation stage for these particles (Christensen *et al.* 2006b). However, the filtration data indicates that the solidosity increases with filtration time during the accumulation stage, whereas no correlation between the effective pressure and the solidosity was observed (Christensen *et al.* 2006b). Thus, the result seems to indicate that creep deformation can be observed during the accumulation stage and not only during the consolidation stage for poly(ST-*co*-AA) latex particles with low content of acrylic acid.

¹ Latex particles with 5% w/w acrylic acid and a hydrodynamic diameter of 0.8 μm was dissolved in 1 mM KCl at pH 5 before they were filtrated at 5 bar and 20 °C.

² Titanium dioxide (anatase) particles with a hydrodynamic diameter of 0.3 μm were suspended in 1 mM KCl solution at pH 8 and filtered at 4 bar and 20 °C.

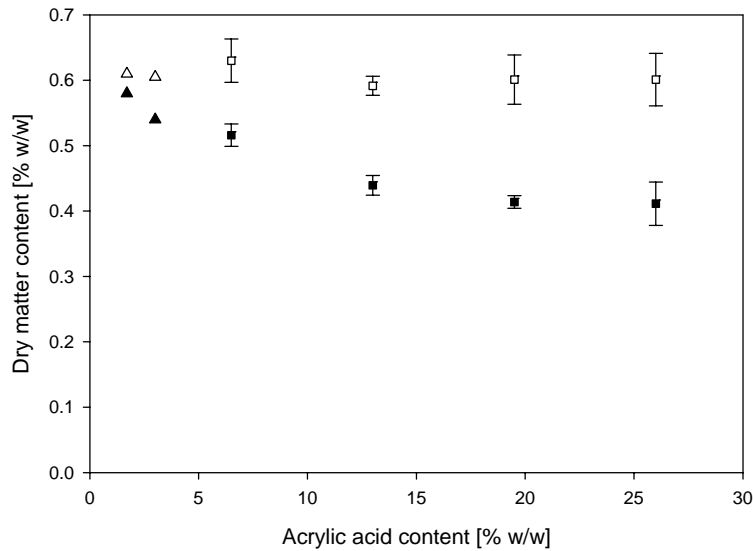

Figure 5.1: Data obtained from Hinge and Keiding (2005), where the dry matter content was measured at the transition between primary and secondary consolidation (closed squares), and at the end of the consolidation stage (open squares). Moreover data obtained from Christensen *et al.* (2006b) has been used, where the dry matter concentration at time zero (closed triangles) and at the end of filtration (open triangles) has been calculated.

Filtration of poly(ST-*co*-AA) latex particles shows that long, negatively charged, acrylic acid polymers at the surface give rise to filter-cake creep (Hinge and Keiding 2005). Further, the retardation time due to creep deformation increases with the acrylic acid content, and thereby the length of the polymer chains (Figure 5.1). The filter-cake creep might be due to viscoelastic compression of the water-soluble polyacrylic acid shell. Moreover, the result might be interesting in the understanding of creep deformation of activated sludge filter cakes. The water content in activated sludge flocs has been estimated to 0.98 – 0.99% w/w (Chung and Lee 2003). Furthermore, extracellular polymeric substances (EPS) contribute with approximately 14% of the total dry matter content in activate sludge flocs (Urbain *et al.* 1993). Hence, the time-dependent deformation of activated sludge filter cakes may be a result of expression of internal water from the sludge flocs and the resulting compression of EPS. However, it is necessary to further develop model materials both to study how the filter-cake creep influences the accumulation stage and to study the mechanism of the compression.

6. Filtration model for activated sludge

It has been shown that activated sludge filter cakes creep and the retardation time due to creep deformation is in the same order of magnitude as the duration of the accumulation stage. Hence, it might be expected that the filter cake also creep during the accumulation stage and that this time-dependent deformation influences the filtration performance as the specific filter cake resistance is a function of the solidsity. It has therefore been concluded that the creep effects influence the whole filtration also the accumulation stage, i.e. the creep has to be adopted in the filtration model when simulating filtrations of activated sludge.

Filter-cake creep has been adopted in the existing filtration model by defining an equilibrium pressure, p_c^{eq} , and an excess pressure, p_{excess} (Christensen and Keiding 2006a). p_c^{eq} is the effective pressure that is needed in order to compress a filter cake in the equilibrium stage, while p_{excess} is the extra pressure that is needed in order to compress a filter cake that has not reached the equilibrium stage. The effective pressure can then be calculated by using Eq. (6.1).

$$p_s = p_c^{\text{eq}} + p_{\text{excess}} \quad (6.1)$$

It has been assumed that p_{excess} increases proportionally with p_c^{eq} and decays exponentially, whereby Eq. (6.2) can be derived.

$$\frac{dp_{\text{excess}}}{dt} = k \frac{dp_c^{\text{eq}}}{dt} - \frac{p_{\text{excess}}}{\tau} \quad (6.2)$$

Thus, the effective pressure is given as a value between p_c^{eq} and $(1+k)p_c^{\text{eq}}$ as shown in Figure 6.1 (Christensen and Keiding 2006a).

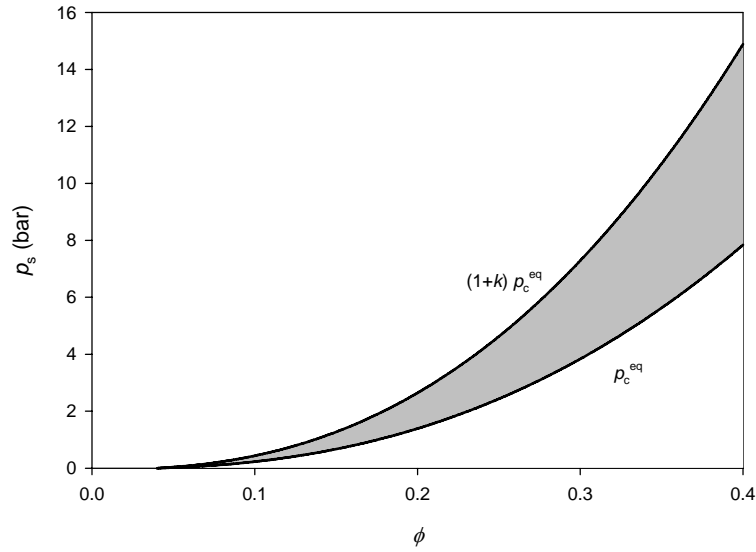

Figure 6.1: Effective pressure as function of solidosity

It is possible to determine k and τ by using stress relaxation experiments, where a filter cake in equilibrium is deformed instantaneously and the applied pressure is monitored until the filter cake reach the new equilibrium stage. The effective pressure throughout the filter cake is equal to the applied pressure if the liquid pressure is zero according to Eq. (3.22). Moreover, the effective pressure is given from Eq. (6.3) if the compression is reversible. Eq. (6.3) has been derived from Eq. (6.1) and (6.2).

$$p_s = p_c^{eq} + \Delta p_c^{eq} \cdot k \cdot \exp\left(-\frac{t}{\tau}\right) \quad (6.3)$$

where Δp_c^{eq} is the difference between the equilibrium pressure before and after the deformation of the filter cake.

It is, moreover, possible to derive Eq. (6.3) from the Terzaghi-Voigt combined model. The following differential equation can be set up for a stress relaxation experiment by using the description of the filter cake used in the Terzaghi-Voigt combined model as shown in Figure 3.5 (Goodwin and Hughes 2000).

$$\left(1 + \frac{E_2}{E_1}\right) \cdot p_s + \frac{G}{E_1} \cdot \frac{dp_s}{dt} = E_2 \cdot \gamma \quad \wedge \quad \frac{d\gamma}{dt} = 0 \quad (6.4)$$

Eq. (6.3) is a solution to the differential equation when

$$k \cdot \Delta p_c^{\text{eq}} = \left(E_1 - \frac{1}{E_1^{-1} + E_2^{-1}}\right) \cdot \Delta\gamma = B \cdot E_1 \cdot \Delta\gamma \quad (6.5)$$

and

$$\tau = \frac{G}{E_1 + E_2} = (1 - B) \cdot \Theta_3 \quad (6.6)$$

and

$$\Delta p_c^{\text{eq}} = \left(\frac{1}{E_1^{-1} + E_2^{-1}}\right) \cdot \Delta\gamma \quad (6.7)$$

Further, combining Eq. (6.5) and Eq. (6.6) gives Eq. (6.8).

$$B = \frac{p_{\text{excess}}^0}{\Delta p_c^{\text{eq}} + p_{\text{excess}}^0} = \frac{k}{1 + k} \quad (6.8)$$

Hence, a link between the constants in the Terzaghi-Voigt combined model and the constants in Eq. (6.2) is given in Eq. (6.6) and (6.8).

A stress relaxation experiment has been performed where the applied pressure was monitored for approximately 25 hours after the deformation (Christensen and Keiding 2006a). It has been observed that at least two relaxation times were needed in order to describe the experimental data properly. Thus, the extended Eq. (6.9) was fitted to the measured data instead of Eq. (6.3). It might also be possible to insert all the found relaxation times in Eq. (6.2) but in this study it has been

avoided in order to keep the model as simple as possible. The relaxation time closest to the duration of the accumulation stage has been used instead.

$$p_s = p_c^{eq} + \Delta p_c^{eq} \cdot \sum_{i=1}^n k_i \cdot \exp\left(-\frac{t}{\tau_i}\right) \quad (6.9)$$

The first relaxation time (τ_1) has been calculated to be 0.54 hr and the second relaxation time (τ_2) to be 7.3 hr. Furthermore, p_c^{eq} has been calculated to be 230 kPa, Δp_c^{eq} to be 130 kPa, k_1 to be 2.3, and k_2 to be 0.86 kPa. Inserting the values from the stress relaxation experiment i.e. τ_2 and k_2 into Eq. (6.7) and (6.9) gives $\Theta_3 = 14$ hr and $B = 0.46$. Similar results have been obtained from stepped pressure experiments of activated sludge where the applied pressure was increased from 2 to 3 bar. The result from these experiments is $\Theta_3 = 13 \pm 2$ hr and $B = 0.49 \pm 0.02$ (Christensen and Keiding 2006b).

The same equation is derived for stress relaxation experiments when Eq. (6.1) and (6.2) are used and the Terzaghi-Voigt combined model is used. Nevertheless, there is also an important difference between the two models as it is assumed that the coefficient of compressibility (a_v) is constant in the Terzaghi-Voigt combined model. This is avoided when using Eq. (6.1) and (6.2). It is well known that the coefficient of compressibility is not constant cf. Eq. (3.15) – (3.18). Thus, the Terzaghi-Voigt combined model seems only to be valid for small compressions of the filter cake as in stepped pressure filtration experiments. Moreover, Eq. (6.1) and (6.2) are easily incorporated in the existing filtration models, and most of the input parameters for the new filtration model can be determined in the same way as done for the conventional filtration models (cf. section 3) whereas the remaining input parameters, i.e. k and τ , can be found using stress relaxation experiments.

Eq. (6.1) and (6.2) have been inserted in the existing filtration model and numerical simulations have been performed using the lowest relaxation time from the stress relaxation experiment. It has been shown that the new filtration model fits experimental data well (Christensen and Keiding 2006a). Moreover, the model is capable of being scaled both with respect to volume and dry matter concentration in the feed suspension (Christensen and Keiding 2006a).

7. Conclusion

The key objectives in filtration dewatering are fast filtrations and high dry matter content in the formed filter cakes. Several filtration models have been developed to calculate the performance of filtrations. These models are suitable when simulating filtration processes of moderately compressible materials, but often not when simulating filtrations of highly compressible materials such as activated sludge. This suggests that the assumption in the state-of-art models may not be fulfilled.

The filtration performance is mainly determined by the properties of the filter cake i.e. the specific filter-cake resistance and the filter-cake compressibility. Activated sludge filter cakes have been studied during the consolidation stage where the piston touches the filter cake. The thickness of the filter cake has been calculated directly from the piston position. Moreover, a pressure transducer has been connected to the piston by a pipe in order to measure the liquid pressure at the top of the filter cake and thereby calculate the average specific filter-cake resistance and the average filter-cake compressibility. It has further been shown how liquid pressure measurements can be used to identify the transition between the accumulation and the consolidation stage.

Consolidation experiments show that the activated sludge filter cakes creep i.e. the solidosity increases at constant effective pressure. Moreover, creep controls more than half of the compression during the consolidation stage. A stress relaxation experiment has been performed, and two relaxation times were found, where the highest time constant was similar to the calculated retardation time for creep deformation found when using the Terzaghi-Voigt combined model to analyse the consolidation data. Both relaxation times are in the same order of magnitude as the duration of the accumulation stage. Moreover, other experiments have shown that the average specific filter-cake resistance increases during the accumulation stage, which might be due to creep effects.

In order to study this phenomenon in more details, well-characterised synthetic poly(ST-*co*-AA) latex particles have been synthesised. Filter cakes that consist of poly(ST-*co*-AA) latex particles creep and the retardation time due to creep deformation increases with the acrylic acid content of the latex particles. Thus, it is possible to study how different values of the retardation time influence

the filtration process. Latex particles with retardation time in the same order of magnitude as the duration of the accumulation stage have been synthesised, and simultaneous measurements of liquid pressure and solidosity through the filter cake indicate a small time-dependent increase of the solidosity. The result shows that the solidosity is a function of time and not only the effective pressure during the accumulation stage for such soft particles.

The reason for the poor agreement between the filtration models and the experimental filtration of biological sludge may therefore be due to creep deformation of waste-activated sludge filter cakes. A viscoelastic model has been developed; where the relaxation times are adopted in one of the conventionally used filtration models. Numerical simulations show that the filtration model fits experimental data for activated sludge filtrations, well. Furthermore, it has been shown that the model is capable of being scaled with respect to volume and dry matter concentration in the feed suspension.

Nomenclature

Roman letters

a_c	Coefficient of compressibility for secondary consolidation [Pa ⁻¹]
a_v	Coefficient of compressibility for primary consolidation [Pa ⁻¹]
$a_{v,av}$	Average coefficient of compressibility defined in Eq. (4.4) [Pa ⁻¹]
B	Ratio between secondary consolidation and total consolidation [-]
c	Ratio between deposited solid material and filtrate volume [kg·m ⁻³]
C_e	Consolidation coefficient [m ² ·s ⁻¹]
D	Hydrodynamic diameter [m]
dv/dt	Filtrate flux [m·s ⁻¹]
E_1	Elastic coefficient of the Terzaghi element [Pa]
E_2	Elastic coefficient of the Voigt element [Pa]
e	Void ratio defined as the ratio between the liquid and the solid volume [-]
G	Viscosity of the Voigt element [Pa·s]
J_R	Correction factor defined in Eq. (4.3) [-]
k	Empirical constant [-]
K	Kozenys constant [-]
k_p	Filter cake permeability [m ²]
m, n	Empirical constants [-]
M	Average ratio of mass of wet filter cake to the mass of dry filter cake at the transition between the accumulation and the consolidation stage [-]
p_a	Empirical constant [Pa]
P_{appl}	Applied pressure [Pa]
p_c^{eq}	Equilibrium pressure [Pa]
Δp_c^{eq}	Difference between the equilibrium pressure before and after a deformation step [Pa]
p_{excess}	Excess pressure [Pa]
p_L	Liquid pressure [Pa]
p_{Piston}	Piston pressure, i.e. the pressure transferred from the piston to the sample [Pa]
p_s	Effective pressure [Pa]
Δp_s	Maximum increase of the effective pressure during the consolidation stage [Pa]

$P_y(\phi)$	Compressive yield stress [Pa]
p_1	Effective pressure at the top of the filter cake [Pa]
p_2	Effective pressure at the bottom of the filter cake [Pa]
q	Superficial velocity of the liquid relative to the solid particles [$\text{m}\cdot\text{s}^{-1}$]
$r(\phi)$	Interaction parameter [-]
R	Gas constant [$\text{J}\cdot\text{K}^{-1}\cdot\text{mol}^{-1}$]
R_{mem}	Medium resistance [m^{-1}]
Re	Reynolds number [-]
s	Mass fraction of solid in a feed suspension [-]
T	Temperature [K]
t	Filtration time [s]
t_c	Consolidation time [s]
U	Degree of consolidation [-]
v_c	Filtrate volume squeezed out during the consolidation stage until t_c [m]
v_∞	Filtrate volume squeezed out during the consolidation stage until $t_c \rightarrow \infty$ [m]
x	Position measured from the filter medium [m]

Greek letters

α	Local specific filter-cake resistance [$\text{m}\cdot\text{kg}^{-1}$]
α_0	Empirical constant [$\text{m}\cdot\text{kg}^{-1}$]
α_{av}	Average specific filter-cake resistance [$\text{m}\cdot\text{kg}^{-1}$]
ϕ	Solidosity [-]
ϕ_{av}	Average solidosity in the filter cake [-]
ϕ_{gel}	Gel point – Solidosity below which the suspension is not networked [-]
ϕ_m	Solidosity for random closed packed mono-disperse particles (equal to 0.64) [-]
ϕ_0	Solidosity at null effective pressure [-]
γ	Strain [-]
$\kappa(\phi, p_s)$	Dynamic compressibility [$\text{s}^{-1}\cdot\text{Pa}^{-1}$]
μ	Viscosity of the liquid [$\text{Pa}\cdot\text{s}$]
ν	Linear velocity of the liquid relative to solid particles [$\text{m}\cdot\text{s}^{-1}$]
Θ_1	Retardation time due to liquid flow resistance of Terzaghi element [s]

Θ_3	Retardation time due to creep deformation of the filter cake [s]
ρ_L	Density of liquid [$\text{kg}\cdot\text{m}^{-3}$]
ρ_s	Density of the solid material [$\text{kg}\cdot\text{m}^{-3}$]
τ	Relaxation time [s]
τ_d	Dummy variable for representing an arbitrary consolidation time ranging up to the given consolidation time, t_c [s]
ω	Material coordinate measured from the filter medium [$\text{kg}\cdot\text{m}^{-2}$]
ω_c	Weight of filter cake per unit area [$\text{kg}\cdot\text{m}^{-2}$]

Literature

- Andersen, N. P. R., Agerbæk, M. L., Keiding, K. (2003). Measurement of electrokinetics in cake filtration. *Colloids and Surfaces A-Physicochem. Eng. Aspects*, 213, 27-36.
- Andersen, N. P. R., Christensen, M. L., Keiding, K. (2004). New approach to determining consolidation coefficients using cake-filtration experiments. *Powder Technol*, 142, 98-102.
- Auzerais, F. M., Jackson, R., Russel, W. B. (1988). The Resolution of Shocks and the Effects of Compressible Sediments in Transient Settling. *J. Fluid. Mech.*, 195, 437-462.
- Baird, R. L., Perry, M. G. (1967). The Distribution of Porosity in Filter Cakes. *Filt. Sep.*, 471-476.
- Bierck, B. R., Wells, S. A., Dick, R. I. (1988). Compressible Cake Filtration - Monitoring Cake Formation and Shrinkage Using Synchrotron X-Rays. *J. Water Pollut. Con. F*, 60, 645-650.
- Brinkman, H. C. (1947). A Calculation of the Viscous Force Exerted by a Flowing Fluid on a Dense Swarm of Particles. *Appl. Sci. Res*, 1, 27-34.
- Buscall, R., White, L. R. (1987). The Consolidation of Concentrated Suspensions .1. The Theory of Sedimentation. *Faraday Trans.*, 83, 873-891.
- Carman, P. C. (1937). Review of literature, confirming validity of Kozeny's theory. *Trans. Instn. Chem. Engrs.*, 15, 150-166.
- Carman, P. C. (1938). Fundamental principles of industrial filtration. *Trans. Instn. Chem. Engrs.*, 85, 168-188.
- Chang, I. L., Chu, C. P., Lee, D. J., Huang, C. (1997). Polymer dose effects on filtration followed by expression of clay slurries. *J. Colloid Interf. Sci*, 185, 335-342.
- Chang, I. L., Lee, D. J. (1998). Ternary expression stage in biological sludge dewatering. *Wat. Res.*, 32, 905-914.
- Channell, G. M., Miller, K. T., Zukoski, C. F. (2000). Effects of microstructure on the compressive yield stress. *AIChE J*, 46, 72-78.
- Channell, G. M., Zukoski, C. F. (1997). Shear and compressive rheology of aggregated alumina suspensions. *Aiche Journal*, 43, 1700-1708.
- Chen, Y. G., Chen, Y. S., Gu, G. W. (2004). Influence of pretreating activated sludge with acid and surfactant prior to conventional conditioning on filtration dewatering. *Chemical Engineering Journal*, 99, 137-143.
- Christensen, M. L., Andersen, N. P. R., Hinge, M., Keiding, K. (2006a). Characterisation of the transition between the filtration and consolidation stage from liquid pressure measurements. *Trans. Filt. Soc.*, 6, 71-78.

- Christensen, M. L., Keiding, K. (2004). Study of the Compositional Heterogeneity in Poly(N-isopropylacrylamide-acrylic acid) Microgels by Potentiometric Titration Experiments. *Colloids and Surfaces A-Physicochem. Eng. Aspects*, 252, 61-69.
- Christensen, M. L., Keiding, K. (2006a). Cake filtration model for suspensions that form viscoelastic filter cakes. Paper V.
- Christensen, M. L., Keiding, K. (2006b). Creep effects in activated sludge filter cakes. Paper IV.
- Christensen, M. L., Sedin, P., Theliander, H., Keiding, K. (2006b). Pressure and concentration profiles in filter cake consisting of core/shell latex particles. Paper VI.
- Chu, C. P., Lee, D. J. (1999). Three stages of consolidation dewatering of sludges. *J. Environ. Eng-Asce*, 125, 959-965.
- Chung, H. Y., Lee, D. J. (2003). Porosity and interior structure of flocculated activated sludge floc. *Journal of Colloid and Interface Science*, 267, 136-143.
- Coulson, J. M. (1949). The flow of fluids through granular beds: Effect of particle shape and voids in streamline flow. *Trans. Instn. Chem. Engrs*, 27, 237-256.
- Dirkzwager, A. H., Duvoort van Engers, L. E., van den Berg, J. J. (1997). Production, treatment and disposal of sewage sludge in The Netherlands. *European Water Pollution Control*, 7, 29-41.
- Eberl, M., Landman, K. A., Scales, P. J. (1996). Scale-up procedures and test methods in filtration: A test case on kaolin plant data (vol 103, pg 1, 1995). *Colloids and Surfaces A-Physicochem. Eng. Aspects*, 111, 159-159.
- Fathi-Najafi, M., Theliander, H. (1995). Determination of Local Filtration Properties at Constant-Pressure. *Sep. Tech*, 5, 165-178.
- Goodwin, J. W., Hughes, R. W. (2000). *Rheology for Chemists An Introduction*. Cambridge, The Royal Society of Chemistry.
- Grace, H. P. (1953). Resistance and Compressibility of Filter Cakes. *Chem. Eng. Prog.*, 49, 303-318.
- Gurjar, B. R. (2001). *Sludge treatment and disposal*. Tokyo, A.A. Balkema publishers.
- Happel, J. (1958). Viscous Flow in Multiparticle Systems - Slow Motion of Fluids Relative to Beds of Spherical Particles. *AIChE J*, 4, 197-201.
- Happel, J., Brenner, H. (1965). *Low Reynolds Number Hydrodynamics*. Prentice-Hall Inc.
- Harbour, P. J., Aziz, A. A. A., Scales, P. J., Dixon, D. R. (2001). Prediction of the dewatering of selected inorganic sludges. *Water Science and Technology*, 44, 191-196.
- Hinge, M. (2005). Unpublished results.

- Hinge, M., Keiding, K. (2005). Applying core/shell poly(styrene-co-acrylic acid) colloids to investigate physio-chemical properties in filtration. In prep.
- Horsfield, M. A., Fordham, E. J., Hall, C., Hall, L. D. (1989). H-1-Nmr Imaging Studies of Filtration in Colloidal Suspensions. *J Magn Reson*, 81, 593-596.
- Houghton, J. I., Stephenson, T. (2002). Effect of influent organic content on digested sludge extracellular polymer content and dewaterability. *Water Research*, 36, 3620-3628.
- Hutto, F., B. (1957). Distribution of porosity in filter cakes. *Chem Eng Prog*, 53, 328-332.
- Kamst, G. F., Bruinsma, O. S. L., deGraauw, J. (1997a). Permeability of filter cakes of palm oil in relation to mechanical expression. *AIChE J*, 43, 673-680.
- Kamst, G. F., Bruinsma, O. S. L., deGraauw, J. (1997b). Solid-phase creep during the expression of palm-oil filter cakes. *AIChE J*, 43, 665-672.
- Kang, S. M., Kishimoto, M., Shioya, S., Yoshida, T., Suga, K. (1990). Dewatering of Extracellular Polymer and Activated Sludges by Thermochemical Treatment. *J Ferment Bioeng*, 69, 117-121.
- Kang, S. M., Kishimoto, M., Shioya, S., Yoshida, T., Suga, K., Taguchi, H. (1989). Dewatering Characteristics of Activated Sludges and Effect of Extracellular Polymer. *J. Ferment. Bioeng*, 68, 117-122.
- Koenders, M. A., Wakeman, R. J. (1996). The initial stages of compact formation from suspensions by filtration. *Chem. Eng. Sci*, 51, 3897-3908.
- Koenders, M. A., Wakeman, R. J. (1997a). Filter cake formation from structured suspensions. *Trans. IChemE, Part A, Chem. Eng. Res. Des.*, 75, 309-320.
- Koenders, M. A., Wakeman, R. J. (1997b). Initial deposition of interacting particles by filtration of dilute suspensions. *AIChE J*, 43, 946-958.
- LaHeij, E. J., Kerkhof, P. J. A. M., Herwijn, A. J. M., Coumans, W. J. (1996a). Fundamental aspects of sludge filtration and expression. *Wat. Res*, 30, 697-703.
- LaHeij, E. J., Kerkhof, P. J. A. M., Kopinga, K., Pel, L. (1996b). Determining porosity profiles during filtration and expression of sewage sludge by NMR imaging. *AIChE J*, 42, 953-959.
- Landman, K. A., Stankovich, J. M., White, L. R. (1999). Measurement of the filtration diffusivity $D(\phi)$ of a flocculated suspension. *AIChE J*, 45, 1875-1882.
- Landman, K. A., White, L. R. (1994). Solid/Liquid Separation of Flocculated Suspensions. *Adv. Colloid Interfac*, 51, 175-246.
- Landman, K. A., White, L. R., Eberl, M. (1995). Pressure Filtration of Flocculated Suspensions. *AIChE J*, 41, 1687-1700.

- Lee, D. J., Ju, S. P., Kwon, J. H., Tiller, F. M. (2000a). Filtration of highly compactible filter cake: Variable internal flow rate. *AIChE J*, 46, 110-118.
- Lee, D. J., Ju, S. P., Kwon, J. H., Tiller, F. M. (2000b). Filtration of highly compactible filter cake: Variable internal flow rate. *Aiche Journal*, 46, 110-118.
- Lee, D. J., Wang, C. H. (2000). Theories of cake filtration and consolidation and implications to sludge dewatering. *Wat. Res*, 34, 1-20.
- Legrand, V., Hourdet, D., Audebert, R., Snidaro, D. (1998). Deswelling and flocculation of gel networks: Application to sludge dewatering. *Wat. Res.*, 32, 3662-3672.
- Li, D. H., Ganczarczyk, J. J. (1990). Structure of Activated-Sludge Flocs. *Biotechnol. Bioeng*, 35, 57-65.
- Massuda, M., Bridger, K., Harvey, M., Tiller, F. M. (1988). Filtration Behavior of Slurries with Varying Compressibilities. *Separation Science and Technology*, 23, 2159-2174.
- Meeten, G. H. (1993). A Dissection Method for Analyzing Filter Cakes. *Chem. Eng. Sci*, 48, 2391-2398.
- Mesri, G. (1973). Coefficient of Secondary Compression. *Journal of the Soil Mechanics and Foundations Division*, 99, 123-137.
- Mikkelsen, L. H. (1999). A physico-chemical approach to the floc strength concept - with dewatering implications. Ph.D thesis. Environmental Engineering Laboratory, Aalborg University. Aalborg, Centertrykkeriet, Aalborg University.
- Mikkelsen, L. H., Keiding, K. (2002). Physico-chemical characteristics of full scale sewage sludges with implications to dewatering. *Wat. Res.*, 36, 2451-2462.
- Neyens, E., Baeyens, J., Dewil, R., De heyder, B. (2004). Advanced sludge treatment affects extracellular polymeric substances to improve activated sludge dewatering. *J. Hazard Mater*, 106, 83-92.
- Nielsen, P. H. (2002). *Activated Sludge - The Floc*. Chichester, Wiley, UK.
- Nielsen, P. H., Frolund, B., Keiding, K. (1996). Changes in the composition of extracellular polymeric substances in activated sludge during anaerobic storage. *Appl. Microbiol. Biot*, 44, 823-830.
- Notebaert, F. F., Wilms, D. A., Vanhaute, A. A. (1975). New Deduction with a Larger Application of Specific Resistance to Filtration of Sludges. *Wat. Res*, 9, 667-673.
- Novak, J. T., Agerbaek, M. L., Sorensen, B. L., Hansen, J. A. (1999). Conditioning, filtering, and expressing waste activated sludge. *J. Environ. Eng-Asce*, 125, 816-824.
- Ormeçi, B., Vesilind, P. A. (2000). Development of an improved synthetic sludge: A possible surrogate for studying activated sludge dewatering characteristics. *Wat. Res*, 34, 1069-1078.

- Palmgren, R. (1996). Quantification of bacterial extracellular polymers in activated sludge - using *P.putida* as model organism. Ph.D thesis. Environmental Engineering Laboratory. Aalborg University. Aalborg, Centertrykkeriet, Aalborg University.
- Parker, D. G., King, P. H., Randall, C. W. (1972). Biological Conditioning for Improved Sludge Filterability. *J. WPCF*, 44, 2066-2077.
- Pelton, R. (2000). Temperature-sensitive aqueous microgels. *Adv. Colloid Interfac*, 85, 1-33.
- Potantin, A. A., Russel, W. B. (1996). Fractal model of consolidation of weakly aggregated colloidal dispersions. *Phys. Rev. E*, 53, 3702-3709.
- Rasmussen, H., Bruus, J. H., Keiding, K., Nielsen, P. H. (1994). Observations on Dewaterability and Physical, Chemical and Microbiological Changes in Anaerobically Stored Activated-Sludge from a Nutrient Removal Plant. *Wat. Res*, 28, 417-425.
- Ruth, B. F. (1946). Correlating filtration theory with industrial practice. *Ind. Eng. Chem*, 38, 564-571.
- Sanin, F. D., Vesilind, P. A. (1996). Synthetic sludge: A physical/chemical model in understanding bioflocculation. *Wat. Environ. Res*, 68, 927-933.
- Sanin, F. D., Vesilind, P. A. (1999). A comparison of physical properties of synthetic sludge with activated sludge. *Wat. Environ. Res.*, 71, 191-196.
- Saunders, B. R., Vincent, B. (1999). Microgel particles as model colloids: theory, properties and applications. *Adv. Colloid Interfac*, 80, 1-25.
- Saveyn, H., Meersseman, S., Thas, O., Van der Meeren, P. (2005). Influence of polyelectrolyte characteristics on pressure-driven activated sludge dewatering. *Colloids and Surfaces a-Physicochemical and Engineering Aspects*, 262, 40-51.
- Sedin, P. (2003). On the Determination and Application of Local Filtration Properties, Ph.D thesis, Division of Chemical Engineering Design, Luleå University of Technology. Luleå, Sweden, Universitetstrykkeriet.
- Sedin, P., Johansson, C., Theliander, H. (2003). On the measurement and evaluation of pressure and solidosity in filtration. *Trans IChemE, Part A, Chem. Eng. Res. Des*, 81, 1393-1405.
- Sherwood, J. D. (1993). Formation of a Cement Filtercake above a Compactible Mudcake. *Chem. Eng. Sci*, 48, 2767-2775.
- Sherwood, J. D., Meeten, G. H., Farrow, C. A., Alderman, N. J. (1991). Concentration Profile within Nonuniform Mudcakes. *Faraday Trans*, 87, 611-618.
- Shirato, M., Murase, T., Iwata, M., Nakatsuka, S. (1986). The Terzaghi-Voigt Combined Model for Constant-Pressure Consolidation of Filter Cakes and Homogeneous Semisolid Materials. *Chem. Eng. Sci*, 41, 3213-3218.

- Shirato, M., Murase, T., Kato, H., Fukaya, S. (1970). Fundamental Analysis for Expression under Constant Pressure. *Filt. Sep*, 7, 277-282.
- Shirato, M., Murase, T., Tokunaga, A., Yamada, O. (1974). Calculations of Consolidation Period in Expression Operations. *J. Chem. Eng. Japan*, 7, 229-231.
- Shirato, M., Sambuich, M., Kato, H., Aragaki, T. (1969). Internal Flow Mechanism in Filter Cakes. *AIChE J*, 15, 405-409.
- Sivaram, B., Swamee, P. K. (1977). A computational method for consolidation coefficient. *Japan Soc. Soil Mech. Found. Eng*, 17, 48-52.
- Smiles, D. E. (1970). A Theory of Constant Pressure Filtration. *Chem. Eng. Sci.*, 25, 985-996.
- Snidaro, D., Zartarian, F., Jorand, F., Bottero, J. Y., Block, J. C., Manem, J. (1997). Characterization of activated sludge flocs structure. *Wat. Sci. Tech*, 36, 313-320.
- Sørensen, B. L., Keiding, K., Lauritzen, S. L. (1997). A theoretical model for blinding in cake filtration. *Wat. Environ. Res*, 69, 168-173.
- Sørensen, B. L., Sørensen, P. B. (1997). Structure compression in cake filtration. *J. Environ. Eng-Asce*, 123, 345-353.
- Sørensen, P. B. (1992). Unified modeling of filtration and expression of biological sludge. Ph.D thesis. Environmental Engineering Laboratory. Aalborg University. Aalborg, Centertrykkeriet, Aalborg University.
- Sørensen, P. B., Agerbaek, M. L., Sorensen, B. L. (1996). Predicting cake filtration using specific filtration flow rate. *Wat. Environ. Res*, 68, 1151-1155.
- Sørensen, P. B., Christensen, J. R., Bruus, J. H. (1995). Effect of Small-Scale Solids Migration in Filter Cakes During Filtration of Waste-Water Solids Suspensions. *Wat. Environ. Res*, 67, 25-32.
- Sørensen, P. B., Hansen, J. A. (1993). Extreme Solid Compressibility in Biological Sludge Dewatering. *Wat. Sci. Technol*, 28, 133-143.
- Tarleton, E. S. (1999). The use of electrode probes in determinations of filter cake formation and batch filter scale-up. *Miner. Eng*, 12, 1263-1274.
- Tarleton, E. S., Hadley, R. C. (2003). The Application of Mechatronic Principles in Pressure Filtration and its Impact on Filter Simulation. *Trans. Filt Soc*, 3, 40-47.
- Tarleton, E. S., Hancock, D. L. (1996). Imaging of filter cakes through electrical impedance tomography. *Filt. Sep*, 33, 491-494.
- Tarleton, E. S., Wakeman, R. J. (1999). Software applications in filter control, data acquisition and data analysis. *Filtr. Sep*, 36, 57-64.

- Teoh, S. K., Tan, R. B. H., D., H., Tien, C. (2001). A Multifunction Test Cell for Cake Filtration Studies. *Trans. Filt. Soc.*, 1, 81-90.
- Teoh, S. K., Tan, R. B. H., Tien, C. (2002). Correlation of C-P cell and filtration test data using a new test cell. *Sep. Purif. Technol.*, 29, 131-139.
- Terzaghi, K., Peck, P. B. (1948). *Soil Mechanics in Engineering Practice*. New York, John Wiley.
- Theliander, H., Fathi-Najafi, M. (1996). Simulation of the build-up of a filter cake. *Filt. Sep.*, 33, 417-421.
- Tien, C. (2002). Cake filtration research - a personal view. *Powder Technol.*, 127, 1-8.
- Tien, C., Bai, R. B., Ramarao, B. V. (1997). Analysis of cake growth in cake filtration: Effect of fine particle retention. *AIChE J.*, 43, 33-44.
- Tiller, F. M., Chow, R., Weber, W., Davies, O. (1981). Filtering Coal Liquids - Clogging Phenomena in the Filtration of Liquefied Coal. *Chem. Eng. Prog.*, 77, 61-68.
- Tiller, F. M., Haynes, J., Stewart, Lu, W.-M. (1972). The role of porosity in filtration VII: Effect of side-wall friction in compression-permeability cells. *AIChE J.*, 18, 13-20.
- Tiller, F. M., Kwon, J. H. (1998). Role of porosity in filtration: XIII. Behavior of highly compactible cakes. *AIChE J.*, 44, 2159-2167.
- Tiller, F. M., Leu, W. F. (1980). Basic data fitting in filtration. *J. Chin. Inst. Chem. Eng.*, 11, 61-70.
- Tiller, F. M., Lu, R., Kwon, J. H., Lee, D. J. (1999). Variable flow rate in compactible filter cakes. *Wat. Res.*, 33, 15-22.
- Tiller, F. M., Yeh, C. S. (1987). The Role of Porosity in Filtration II. Filtration Followed by Expression. *AIChE J.*, 33, 1241-1256.
- Urbain, V., Block, J. C., Manem, J. (1993). Bioflocculation in Activated-Sludge - an Analytic Approach. *Water Research*, 27, 829-838.
- Usher, S. P., De Kretser, R. G., Scales, P. J. (2001). Validation of a new filtration technique for dewaterability characterization. *AIChE J.*, 47, 1561-1570.
- Vaxelaire, J., Cezac, P. (2004). Moisture distribution in activated sludges: a review. *Wat. Res.*, 38, 2215-2230.
- Wakeman, R. J. (1981). The Formation and Properties of Apparently Incompressible Filter Cakes under Vacuum on Downward Facing Surfaces. *Trans IChemE, Part A, Chem. Eng. Res. Des.*, 59, 260-270.
- Wakeman, R. J., Sabri, M. N., Tarleton, E. S. (1991). Factors Affecting the Formation and Properties of Wet Compacts. *Powder Technol.*, 65, 283-292.

Wakeman, R. J., Tarleton, E. S. (1999). Filtration: Equipment selection, modelling and process simulation. Elsevier Science Lth.

Winther, L., Henze, M., Linde, J. J., Jensen, H. T. (2004). Spildevandsteknik. Polyteknisk Forlag.

Zhou, Z. W., Scales, P. J., Boger, D. V. (2001). Chemical and physical control of the rheology of concentrated metal oxide suspensions. Chem. Eng. Sci, 56, 2901-2920.

List of supporting papers

- I. Christensen M. L., and Keiding K. Study of the compositional heterogeneity in poly(N-isopropylacrylamide-acrylic acid) microgels by potentiometric titration experiments. *Colloids and Surfaces A: Physicochem. Eng. Aspects*. (2005), 252: 61-69.

- II. Andersen N. P. R., Christensen M. L., and Keiding K. New approach to determining consolidation coefficients using cake-filtration experiments. *Powder Technol.* (2004), 142: 98-102.

- III. Christensen M. L., Andersen N. P. R., Hinge M., and Keiding K. Characterisation of the transition between the filtration and consolidation stage from liquid pressure measurements. *Trans. Filt. Soc.* (2006), 6: 71 – 78.

- IV. Christensen M. L., and Keiding K. Creep effects in activated sludge filter cakes. *Submitted Aug. 2005 to Powder Technol.*

- V. Christensen M. L., and Keiding K. Filtration model for suspensions which form filter cakes with creep behaviour. *Submitted to AIChE.*

- VI. Christensen M. L., Sedin P., Theliander H., and Keiding K. Pressure and concentration profiles in filter cake consisting of core/shell latex particle. *Accepted for publication June 2006 in Colloids and Surfaces A: Physicochem. Eng. Aspects.*

Publications not included in this thesis

Christensen M. L., and Eriksen N.T.. Growth and proton exchange in recombinant *Escherichia coli* BL21. *Enzyme Microb. Tech.*, (2002) 31:566–574.

Andersen N. P. R., Christensen M. L., Keiding K., and Petrinic I. Investigation of filtration conditions for nanofiltration of reactive dye printing wastewater. Proceedings - FILTECH, Weisbaden, Germany (2005), II-596 – II-603, and *accepted for publication 2006 in Trans. Filt. Soc.*

Christensen M. L., Andersen N. P. R., and Keiding K. Creep effects in filtration processes. Conference contribution. The FILTRATION Society: New developments in filtration technology, February 28, 2006, Loughborough, England.

The Section of Chemistry Ph.D. Dissertation Series:

1. NIELS PEDER RAJ ANDERSEN. 2003. Investigation of relations between fundamental solid/liquid suspension properties and dewatering characterisation parameters.
2. MORTEN LYKKEGAARD CHRISTENSEN. 2006. The effect of filter cake viscoelasticity on filtration – a study of activated sludge dewatering.