



Experimental analysis and proof-of-concept of distributed mechanisms for local area wireless networks

Tonelli, Oscar

Publication date:
2014

Document Version
Accepted author manuscript, peer reviewed version

[Link to publication from Aalborg University](#)

Citation for published version (APA):
Tonelli, O. (2014). *Experimental analysis and proof-of-concept of distributed mechanisms for local area wireless networks*. Department of Electronic Systems, Aalborg University.

General rights

Copyright and moral rights for the publications made accessible in the public portal are retained by the authors and/or other copyright owners and it is a condition of accessing publications that users recognise and abide by the legal requirements associated with these rights.

- Users may download and print one copy of any publication from the public portal for the purpose of private study or research.
- You may not further distribute the material or use it for any profit-making activity or commercial gain
- You may freely distribute the URL identifying the publication in the public portal -

Take down policy

If you believe that this document breaches copyright please contact us at vbn@aub.aau.dk providing details, and we will remove access to the work immediately and investigate your claim.

Experimental analysis and proof-of-concept of distributed mechanisms for local area wireless networks

PhD Thesis

by

Oscar Tonelli



AALBORG UNIVERSITY
DENMARK

A dissertation submitted to
Department of Electronic Systems,
the Faculty of Engineering and Science, Aalborg University
in partial fulfillment for the degree of
PhD Degree,
Aalborg, Denmark
September 2014.

Supervisors:

Troels B. Sørensen, PhD, (main supervisor)
Associate Professor, Aalborg University, Denmark.
Preben E. Mogensen, PhD,
Professor, Aalborg University, Denmark.
Principal Engineer, Nokia Networks, Aalborg, Denmark.
Gilberto Berardinelli, PhD,
Post doc, Aalborg University, Denmark.

Opponents:

Peter Koch (chairman), PhD
Associate Professor, Aalborg University, Denmark.
Linda Doyle, PhD
Professor, Trinity College University of Dublin, Ireland.
Mark Cudak
Principal Research Specialist, Nokia Networks, Rolling Meadows, USA.

List of published papers:

- Oscar Tonelli, Gilberto Berardinelli, Andrea Fabio Cattoni, Troels Bundgaard Sørensen, Preben Mogensen, "Software architecture design for a dynamic spectrum allocation-enabled cognitive radio testbed", *The 2011 European Signal Processing Conference (EUSIPCO)*, Barcelona, August 2011.
- Oscar Tonelli, Gilberto Berardinelli, Fernando Menezes Leitão Tavares, Andrea Fabio Cattoni, Petar Popovski, Troels Bundgaard Sørensen and Preben Mogensen "Real-world experimentation of distributed DSA network algorithms", Book Chapter in *Evolution of Cognitive Networks and Self-Adaptive Communication Systems*, IGI global, 2013.
- Oscar Tonelli, Gilberto Berardinelli, Fernando Menezes Leitão Tavares, Andrea Fabio Cattoni, Istvan Kovacs, Troels Bundgaard Sørensen, Petar Popovski, Preben Mogensen "Experimental validation of a distributed algorithm for dynamic spectrum access in local area networks", *VTS Vehicular Technology Conference, IEEE*, Dresden, June 2013.
- Oscar Tonelli, Ignacio Rodriguez, Gilberto Berardinelli, Andrea Fabio Cattoni, Jakob Lindbjerg Buthler, Troels Bundgaard Sørensen, Preben Mogensen "Validation of an Inter-Cell Interference Coordination Solution in Real-World Deployment Conditions", *VTS Vehicular Technology Conference, IEEE*, Seoul, May 2014.

Copyright ©2014, Oscar Tonelli

This thesis has been submitted for assessment in partial fulfillment of the PhD degree. The thesis is based on the submitted or published scientific papers which are listed above. Parts of the papers are used directly or indirectly in the extended summary of the thesis. As part of the assessment, co-author statements have been made available to the assessment committee and are also available at the Faculty. The thesis is not in its present form acceptable for open publication but only in limited and closed circulation as copyright may not be ensured.

“We choose to go to the moon. We choose to go to the moon in this decade and do the other things, not because they are easy, but because they are hard.”

John Fitzgerald Kennedy,
“September 12, 1962”

Abstract

In order to sustain the exponential growth of data traffic due to the increasing diffusion of internet-based communication services, a Fifth Generation (5G) of radio access technology is currently being envisaged. The ultra-dense deployment of small cells in local area is considered a fundamental requirement for 5G systems, enabling to achieve very ambitious capacity targets by reducing the distance between the user and its serving Access Point (AP). The centralized management of network configurations in indoor scenarios is, however, a critical challenge. Several limitations in the resource planning (e.g. the location of user-deployed APs in private premises cannot be foreseen in advance) may indeed hinder the achievement of the desired performance targets. In particular, the high levels of inter-cell interference due to the ultra-dense deployment are perceived as a major concern. Distributed network approaches have been proposed in the past years, as a possible solution to such problems. Specifically, distributed schemes for the Frequency Domain Inter-Cell Interference Coordination (FD-ICIC) may provide successful interference mitigation capabilities in the network, by enabling multiple APs of dynamically adjusting their frequency reuse.

In literature, the validation of distributed network concepts is typically carried out by means of system-level simulations, where reference scenarios and stochastic propagation models are usually employed. Despite the technical advantages of such approaches (e.g. rapid evaluation of large number of configurations, statistical coverage) the reliability of these studies has been often object of debate in the research community. The limited accuracy in the description of the multi-link characteristics of a wireless network is, in particular, of major concern. In order to improve the validation of such concepts, performance results obtained in simulations should be therefore validated with practical experiments conducted in realistic operating conditions on the field.

The objective of the thesis is to enable the experimental validation of distributed network concepts by developing tools and methodologies for the setup and execution of trials. The evaluation of **FD-ICIC** schemes is the main research focus in this study.

A network testbed —based on Software Defined Radio (**SDR**) platforms— has been realized in this project, supporting the implementation of the algorithms on the hardware and enabling their performance evaluation with *live execution* experiments. Path loss measurement campaigns have been conducted in indoor propagation scenarios, aiming at acquiring detailed information about the characteristics of wireless links in practical network deployments. Simulation-based studies exploiting such measurements (i.e. defined in the thesis as *hybrid-simulations*), have been then employed to characterize the differences between real-world deployment scenarios and common scenario modeling assumptions in simulations.

An **SDR** software framework —**ASGARD**— has been specifically developed in this thesis, easing the design of distributed network applications and the realization of wireless systems research prototypes. Practical methodologies have been developed, supporting the analysis of runtime execution aspects of the algorithms, as well as the investigation of larger-scale network features. A specific **FD-ICIC** algorithm named Autonomous Component Carrier Selection (**ACCS**), has been analyzed in the experiments, aiming at its performance validation. The obtained results —from both hybrid-simulations as well as live execution experiments— allowed to establish that the performance gains (e.g. increased throughput to users in high-interference conditions), previously presented in simulation-based literatures studies, are actually verified by the experience on the field. In this sense, the experiments conducted in this thesis allow to assess that, despite the presence of minor inaccuracies, the scenario modeling assumptions commonly adopted in simulations constitute a reliable basis for the validation of distributed network concepts.

Dansk Resumé¹

For at kunne opretholde den eksponentielle vækst af data overførsler, som skyldes stigende spredning af internetbaserede services indenfor kommunikation, må man kunne forudse en 5. generation af radio access teknologi. Den ultra-kompakte udnyttelse af små celler i lokale områder er en fundamental forudsætning for 5G systemer, som gør det muligt at opnå meget ambitiøse mål for kapacitet, ved at reducere afstanden mellem brugeren og forbindelsespunktet. Den centraliserede håndtering af indendørs netværkskonfigurationer er dog en svær udfordring. Mange begrænsninger i ressourceplanlægningen, (f.eks. kan lokationen af brugeranvendte servicepunkter i private boliger ikke forudses), kan i stor grad være en hindring for at opnå de ønskede performance mål. Især den store grad af interferens imellem de indbyrdes celler, som opstår på grund af den ultra-kompakte udnyttelse anses som et stort problem. Man har forsøgt sig med distribuerede netværk, som en mulig løsning i de senere år. Specielt kan distribuerede systemer til at koordinere Frekvens Domæne Interferens imellem de indbyrdes celler (FD-ICIC), vise sig at skabe en succesfuld mulighed for reduktion af interferens i netværket, ved at gøre det muligt for de mange servicepunkter dynamisk at tilpasse sig deres genbrug af frekvens.

Det står skrevet, at valideringen af det distribuerede netværkskoncept typisk gennemføres ved hjælp af system niveau simuleringer, hvor man normalt anvender reference scenarier og stokastiske spredningsmodeller. Selvom det er en teknisk fordel at gøre sådan, (f.eks. hurtig evaluering af et stort antal konfigurationer, statistisk dækning), har disse studier ofte været genstand for diskussion i forskningsmiljøerne. Specielt den begrænsede nøjagtighed i beskrivelsen af multilink karakteristikkene i et trådløst netværk vækker bekymring. For at forbedre valideringen af sådanne koncepter, skal performance resultater opnået ved hjælp af

¹The author is extremely thankful to Mads Lauridsen and Dorthe Sparre for their support in translating and proofreading this abstract.

simuleringer valideres ved hjælp af praktiske eksperimenter, som skal udføres i områder med realistisk fungerende forhold

Formålet med tesen er at muliggøre eksperimentel validering af distribuerede netværkskoncepter ved at udvikle værktøjer og metoder til opstilling og udførelse af forsøg. Det forskningsmæssige hovedfokus i dette studie er på evaluering af FD-ICIC teknikker.

I dette project er der realiseret en netværks testbed —baseret på SDR platforme, som supporterer implementation af algoritmer i hardwaren og gør det muligt at evaluere algoritmernes ydelse i live eksperimenter. Der er udført udbredelsestabsmålinger i indendørs miljøer, målrettet mod at indhente detaljeret information om trådløse forbindelsers egenskaber i praktiske netværks opstillinger. Simuleringsbaserede studier som udnytter disse målinger (defineret i tesen som hybrid simuleringer) er blevet anvendt til at karakterisere forskellen mellem scenarier i virkelighedens verden og typiske modelantagelser i simuleringer.

I denne tese er der specifikt udviklet en SDR software struktur, som letter designet af distribuerede netværksapplikationer og realiseringen af prototyper af trådløse systemer. Der er udviklet praktiske metoder, som supporterer analyse af algoritmernes egenskaber for runtime afvikling såvel som undersøgelse af stor-skala netværks egenskaber. En specifik FD-ICIC algoritme kaldet ACCS er blevet undersøgt i eksperimenterne for at validere dens ydelse. De opnåede resultater —fra både hybrid simuleringer såvel som live eksperimenter— tillod at fastsætte at de ydelsesforbedringer (for eksempel øget throughput for brugere i tilstande med høj interferens), som tidligere er præsenteret i simuleringsbaserede literaturstudier, virkelig kan verificeres med eksperimenterne. I denne forstand, tillader eksperimenterne foretaget i denne tese at vurdere, på trods af tilstedeværelsen af mindre unøjagtigheder, at de modelantagelser som ofte er anvendte i simuleringer udgør et troværdigt grundlag for at validere distribuerede netværkskoncepter.

Preface and Acknowledgments

This PhD dissertation is the result of a three-year research project carried out at the Radio Access Technology (RATE) Section, Department of Electronic Systems, Aalborg University (AAU), Denmark. The work was conducted alongside with the obligatory courses and teaching obligations required for attaining the PhD degree. The research was supervised by Associate Professor Troels B. Sørensen (Aalborg University, Aalborg, Denmark), Professor Preben E. Mogensen (Aalborg University, Nokia, Aalborg, Denmark) and Post-doc Gilberto Berardinelli (Aalborg University, Aalborg, Denmark).

This thesis investigates the problems related to the experimental validation of distributed wireless network concepts, specifically focusing on solutions for the resource management in next-generation (5G) small cells deployments in local area. A wide range of topics are actually discussed in the thesis. Software defined radio is the main technology component employed for the realization of the testbeds. Path loss models and deployment scenarios utilized in system-level simulators have been also discussed, in order to understand the differences between simulation-based studies and experiments. Inter-cell interference coordination in the frequency domain is the main object of the experimental analysis. Practical and methodological aspects, related to the execution of trials, have also received major attention.

I would like to express my sincere gratitude to my supervisors for their guidance and support throughout the entire course of this PhD project. I would like to extend this gratitude also to Dr. Istvan Z. Kovacs who shared precious knowledge with me during my first years at Aalborg University.

A special thanks to Gilberto Berardinelli who assisted me in every possible way in the completion of my PhD studies. I also want to thank Andrea F. Cattoni,

because if not for his contribution, I could have not started this journey in the first place.

I want to express my gratitude to all people and colleagues at RATE Section and Nokia for their collaboration and the nice time spent together during these years. A special thanks to Mads Lauridsen, Ignacio Rodriguez, Fernando Tavares and Nurul Huda Mahmood. I cannot forget all my italian (and almost-italian) friends who shared with me all this happy time in Denmark —in chronological order: Nicola Marchetti, Mauro Pelosi, Gilbert Micallef, Claudio Coletti, Carlo Galiotto, Simone Barbera, Davide Catania and Stefano Martin.

Finally, I want to thank my family for their support, and love, during all this time spent away from home. I want to thank Alexandra, who is now my new family, and whose affection gives me the strength to face every new day.

Oscar Tonelli
Aalborg, September 2014

Contents

Abstract	iii
Dansk Resumé	v
Preface and Acknowledgments	vii
1 Introduction	1
1.1 Improving the user capacity: dense network deployments in local area	3
1.2 Experimental Validation	5
1.3 Thesis Objectives	7
1.4 Thesis Outline and Contributions	9
2 Experimental validation of wireless concepts in local area	15
2.1 Introduction	15
2.2 Experimental activities in local area	16
2.3 Experimental activities with Cognitive Radios	20

2.4	Testbeds and trials	22
2.5	Summary	32
3	Design of an SDR platform for wireless network testbeds	33
3.1	Introduction	33
3.2	Design aspects of SDR platforms	34
3.3	Software Frameworks for SDR	35
3.4	Design requirements for a distributed network testbed in local area	39
3.5	The ASGARD software framework	40
3.6	Discussion	51
4	Experimental methodology and practical execution aspects	55
4.1	Introduction	55
4.2	Terminology and requisites of experimental trials	56
4.3	Experimental objectives	58
4.4	Live Execution	60
4.5	Hybrid Simulation approach and Channel Sounder	61
4.6	Practical aspects in the testbed management	72
4.7	Summary	75
5	Link path loss in indoor deployment scenarios	77
5.1	Introduction	77
5.2	Measurement campaigns in indoor environments	77
5.3	Estimating the path loss	80

5.4	Critical analysis of the data	80
5.5	Path loss modeling	84
5.6	Impact of path loss and scenario modeling on multi-link performance aspects	87
5.7	Scenario models comparison	90
5.8	Discussion	93
6	Validation of distributed concepts for local area wireless networks	95
6.1	Introduction	95
6.2	Inter-Cell Interference Coordination in local area small cells	96
6.3	The Autonomous Component Carrier Selection algorithm	98
6.4	Realization of a testbed for ACCS	101
6.5	Live trials with ACCS	105
6.6	ACCS analysis with Hybrid Simulations	115
6.7	A testbed for Interference Rejection Combining	125
6.8	A testbed for a distributed nodes synchronization	126
6.9	Summary	127
7	Conclusions and Future Work	129
7.1	Summary and Conclusions	129
7.2	Recommendations and guidelines	132
7.3	Future Work	135
A	A testbed for Interference Rejection Combining	137
A.1	Testbed setup and experiments	138

A.2 Performance Evaluation	140
A.3 Discussion	142
B A testbed for a distributed nodes synchronization	145
B.1 Distributed runtime synchronization algorithm	145
B.2 Testbed realization	147
B.3 Experimental results	148

Introduction

The rapid diffusion of new Internet-based communication services is pushing the user demand for ubiquitous connectivity and broadband wireless data access. In order to cope with an exponential increase in the data traffic, as well as providing low-latency communication services, wireless network infrastructures are expected to undergo major upgrading in the upcoming years. New technology solutions are currently being pursued —enabling to improve the network capabilities beyond the present-day limitations.

At the moment of writing of this thesis, the Fourth Generation (4G) of mobile networks is being rolled out; its large-scale exploitation is still in its early stages. In the meanwhile, however, a newer generation of wireless communication systems is already under intensive investigation, aiming at identifying the solutions able to satisfy the traffic requirements of the next decade. When focusing on the capacity improvement of mobile cellular networks, there is a widespread agreement —in both the industry and the academia— that the deployment of heterogenous cells with different coverage ranges, will be a fundamental requirement [1]. Outdoor macro and micro cells aim at delivering high-data rate with about 95% service coverage. Peak data-rates in hotspot and indoor areas, instead, should be provided by the ultra-dense deployment of small cells with a lower transmit power (e.g. pico-, femto- cells).

The improvement of wireless services in local area is motivated by the fact that the largest part of the data traffic is expected to be generated inside buildings (in a 70-30 proportion in respect to outdoor) [2]. At the present day the IEEE 802.11

family of standards is, by far, the most widespread solution for network access in local area —constituting *de-facto* the reference technology. The evolution of mobile/cellular networks aims at becoming a performing substitute of Wireless Local Area Network (WLAN) systems, despite their current penetration is still fairly limited.

A number of factors currently challenge the deployment of high-rate wireless networks in local area. First, the deployment of network access points (APs) inside private premises (e.g. residential houses and offices) cannot be foreseen in advance —signal coverage and co-channel interference issues are then likely to arise. Furthermore, the provision of low-latency and high-speed backhauling, inside buildings, can be significantly more complex compared to the outdoor macro cells case. In this context, traditional approaches to the centralized network management, e.g. planned frequency reuse schemes, may be ineffective. As an alternative, researchers are currently focusing on the development of distributed network solutions, which rely on the capabilities of “smart” network devices for enabling the dynamic optimization the transmission parameters. In this way, the network will become capable of self-reconfiguration thus able to adapt to variable deployment and operating conditions. One of the most relevant communication paradigms, in this context, is Cognitive Radio (CR). As defined by Haykin in [3] cognitive radios are devices able to *learn* from the surrounding environment and reconfigure their transmission parameters in order to optimize their communication capabilities. Specific applications of CR have been identified in the Dynamic Spectrum Access (DSA) and in distributed schemes for the interference management [4]. Elements of artificial intelligence, machine learning, game theory and other decision-making solutions have been introduced throughout the years in relation to CR applications [5].

One of the main challenges in the development of distributed network mechanisms is their performance validation. In literature works, novel wireless communication proposals are typically verified by means of system-level simulations. Simulations are a particularly convenient tool to employ, due to their reduced complexity in the analysis which is achieved by the use of several abstraction models. As a consequence, in simulations, a large number of configuration parameters can be easily analyzed in relatively short time. The modeling of deployment scenarios in simulations, often relies on stochastic channel propagation models and geometrically regular building facilities. The performance of distributed network solutions, however, is sensitive to the nodes topology (e.g. physical location of nodes, multi-link channel characteristics). Inaccuracies in the scenario modeling assumptions, adopted in simulations, may be therefore source of inaccuracies for the performance evaluation. In this context, given the requirements for robustness and reliability of solutions targeting the network resource management, there is a growing interest, from both industry and academia, for more tangible proofs of their contribution.

Several experimental works have been presented during the past years, in relation

to distributed and cognitive solutions to the spectrum management [6]. Specific attention has been given so far to single-link —Physical Layer (PHY)— applications, protocols for sensor networks, mesh networks as well as WiFi systems. Experiments with distributed decision-making concepts, in the context of small cell local area deployments, are still a relatively under-explored research field. The multi-link network perspective, in particular, is an aspect traditionally neglected, due to the several practical challenges involved in the management of experiment trials with large testbed configurations.

1.1 Improving the user capacity: dense network deployments in local area

Different radio access technologies are currently available for enabling the network connectivity through the wireless medium. At the present day, high data-rate outdoor coverage and mobility support are typically targeted by standards such as Long Term Evolution (LTE), Long Term Evolution - Advanced (LTE-A) and WiMax 802.16e. The coverage of indoor local area scenarios is instead proper of the WiFi 802.11 family of standards.

The International Telecommunications Union (ITU) defined an updated list of performance targets aiming at coping with the traffic demands for the years 2020-25. In general terms, it is expected that future wireless networks will be able to support 1000 times more capacity than current generation technologies, as well as peak data rates of about 10 Gbps in low mobility conditions, and latencies in the order of 1ms. Such performance can be achieved only by introducing a number of technology enhancements which are now commonly recognized as part of the 5G of wireless communication systems.

Reaching the ITU performance objectives would in principle require 5G solutions to improve the current conditions relatively to these three key aspects:

- Spectrum allocation
- Single-link spectral efficiency
- Number of deployed cells

Spectrum allocations of minimum 200 MHz are expected to be necessary to meet the target data rates [2]. Specific bandwidth assignments are currently the subject of discussion within the ITU. From the technical perspective, major architectural differences (i.e. Radio Frequency (RF) design of transceivers, Medium Access Control (MAC) protocols, resource management, network deployment) are

expected to take place, in relation to the decision of operating in the millimeter wave range (>20 GHz) or in the centimeter wave range (<20 GHz). The improvement of the single-link spectral efficiency is an extremely challenging goal since the theoretical Shannon bound for single-link capacity has already been approached by 4G systems within few decibels [7]. The exploitation of higher-order modulation schemes can be however better achieved if the range of the usable Signal to Interference plus Noise Ratio (SINR) can be extended. Multiple Input Multiple Output (MIMO) antenna solutions are currently considered the main technological element which can provide such improvements. Increasing the overall network capacity is likely to require also a very large number of cells to be deployed. Heterogenous Networks (HetNet) employing multiple base stations with different transmit power and capabilities, can help in extending the signal coverage in hotspot areas and, at the same time, offload the macro cell layer from heavy data traffic load. The deployment of small cells (pico/femto) in indoor locations, moreover, is expected to have a fundamental role in providing increased capacity.

The deployment of a local area cellular infrastructure based on femtocells/low-power APs faces a number of challenges:

- *Uncoordinated deployment* - Due to the presence of user-deployed access points in private premises the network topology cannot be foreseen in advance.
- *Indoor environment propagation* - Due to the dense intervening clutter, wireless links with “free paths” are limited —over distance— compared to the outdoor case (e.g in this case signals may find alternative paths over roofs or around buildings). Moreover, in indoor the impact of the clutter is also higher due to the proximity of the nodes to the obstacles: the links involved are more likely to be subjected to significant changes in propagation due to the movement of terminals or dynamic propagation environments.
- *Dense deployment scenarios* - Due to the limited signal propagation, a large number of nodes will be required to be deployed in order to provide ubiquitous coverage. Furthermore, in a context of Closed Subscriber Group (CSG)(i.e. users are allowed to connect only to authorized APs), an even higher number of cells may be present in the same area of space.
- *Limitation in backhaul connectivity* - High-speed, low-latency backhaul links may be difficult to install inside private building premises.

As a consequence, the combination of the previous aspects may then lead to the following issues:

- *Co-channel interference* - Assuming spatially deployed cells to be using the same portion of the spectrum and operating in CSG mode in a limited area

of space, the adoption of fixed reuse schemes of the frequency resources may lead to severe co-channel interference.

- *Limited coordination* - The limitations in backhaul connectivity may hinder the data-exchange between neighboring cells, thus requiring alternative solutions for inter-cell coordination.
- *Asymmetric Uplink/Downlink* - Assuming a Time Division Duplexing (TDD) mode of operation and multiple uncoordinated neighboring cells, the asynchronous pattern of Uplink (UL) and Downlink (DL) transmissions between the users and the APs further complicate the prediction and mitigation of interference.
- *Lack of centralized control and optimization* - Due to the impossibility of having complete control of the network deployment, fully centralized optimization strategies of cells resources may be ineffective.

Considering all the challenges and limitations in the adoption of traditional — centralized— approaches to the network management, the idea that future 5G systems should rely on distributed mechanisms is gathering increasing consensus in the research community. In particular, researchers are focusing on the design of communication solutions which foresee the possibility of having autonomous decision-making features, locally at the nodes. Communication systems with such type of characteristics have been widely investigated in the past years, specifically in the context of CR and DSA research [5]. The applications of such concepts in literature works mainly related to: advanced spectrum sensing techniques, MAC protocols for the opportunistic spectrum access, mechanisms for the protection of the incumbent primary users. More recently, the adoption of cognitive approaches has been extended also to distributed solutions for the network management in cellular context. A more detailed discussion on this topic as well as the description of specific algorithm proposals will be addressed in Chapter 6.

1.2 Experimental Validation

Novel concepts and ideas for technological improvements require extensive analysis and testing before being considered for inclusion in new products or standards. The same principle applies to new proposals for 5G systems. In this thesis we refer to the concept of validation as *the act of numerically establishing the performance of a system feature under realistic operating conditions*. Analytical approaches are often utilized to obtain a first numerical evaluation of the potential benefits that the considered solutions can provide. Further steps of validation can be achieved improving both the accuracy of the results and the level of realism of the analysis. In engineering-related applications, where complex technical and physical aspects

are typically involved in the analysis, software simulations are widely regarded as the most agile tool for validation purposes, providing fast and accurate numerical estimations. This is also the case with wireless network systems. Stochastic simulation models are often employed allowing to significantly reduce the modeling complexity of the considered phenomena (e.g. the link path-loss characteristics due to the signal propagation in the environment). The utilization of stochastic abstraction models for validation purposes has, however, some known limitations: due to the very specific assumptions made for their utilization, the obtained performance results may be “statistically accurate”, but at the same time cannot be considered as representative of the full complexity of practical operating conditions in reality.

In order to achieve a higher level of accuracy and realism in the description of wireless systems — providing insights difficult to obtain otherwise— experiments and measurements on the field should be employed. Due to their nature of high-detail and high-specificity, experiments should be seen as complementary (in terms of validation strategy) to simulation-based studies.

From the perspective of the experimental validation, the most interesting aspect of distributed network solutions is the analysis of multiple autonomous decision-making processes, jointly concurring in determining the overall performance of a network. In this context, critical elements are:

- The network topology (i.e. the connectivity/bonding of nodes over multiple wireless links)
- The variations introduced by the deployment environment in terms of channel propagation
- Non-idealities, errors, delays, in the runtime execution of the system.

For the most realistic type of analysis, all previous conditions should be considered at the same time during the experiments. Practical challenges, however, may discourage this type of approach. The adoption of intermediate steps, e.g. tackling different aspects independently, can be an optimal strategy in order to achieve the desired validation goals.

In distributed system configurations, acquiring a multi-link perspective is particularly important as complex dynamics can arise, from the interaction of multiple independent decision-making processes. The adoption of a network-oriented approach to the experimental validation is then a new challenge —in comparison to the prior literature work— which will be specifically addressed by this thesis.

1.3 Thesis Objectives

This PhD project pursues the experimental validation of distributed schemes for future generation local area wireless networks. The execution of experimental trials aims at verifying the performance of a wireless system, in realistic operating conditions. Experiments provide real-world information about the system performance, enabling also the verification of results obtained in simulations. A representation of the general scope of the thesis is depicted in Figure 1.1. Topics highlighted in green are specifically addressed in the discussion.

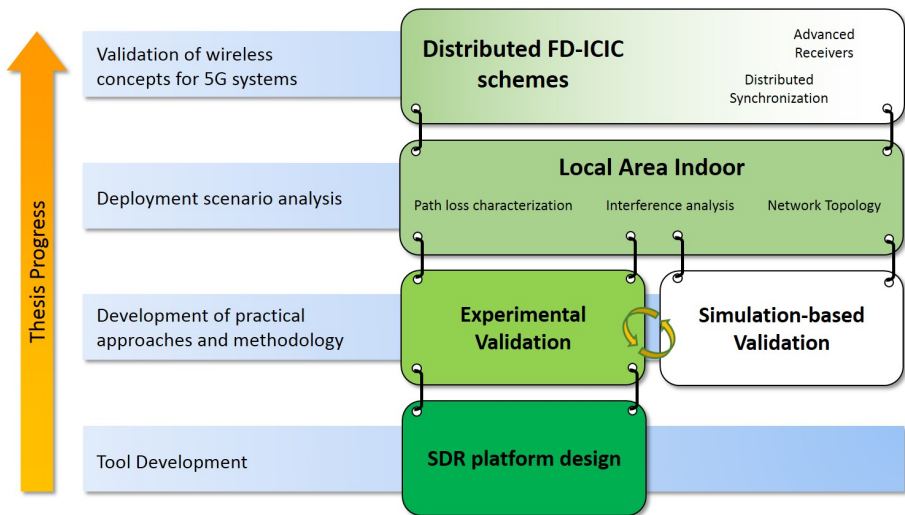

Fig. 1.1: In green are highlighted the topics within the scope of this thesis

Enabling the experimental validation of wireless network concepts requires at first to develop a testbed platform capable of supporting the execution of the system features of interest. The first objective of the thesis is then to analyze the characteristics of existing testbeds (with a particular interest in SDR testbeds utilized in CR studies), in order to evolve their support in respect to distributed network algorithms and the management of experiments with a larger number of nodes.

The challenges related to the development of research testbeds are a key topic discussed in this thesis —as a starting element for the analysis, the following have been individuated as fundamental requirements for the testbed design:

- *Scalability* - a large number of nodes and multiple experimental trials are needed to provide minimum statistical coverage of the network characteristics and interference patterns.

- *Flexibility* - the testbed platform should enable the fast-prototyping and the support for an agile experimentation process allowing the optimization of the system configuration parameters.
- *Centralized and remote control* - running experiments with multiple devices can be extremely time consuming. Proper solutions must be identified to ease the centralized testbed management and acquisition of the data.

The validation of simulation results with experiments encounters several challenges, particularly due the practical limitations in reproducing the scenario deployment assumptions. While in simulations multiple and large network deployments can be easily generated and analyzed, the same conditions do not apply to experiments in the real-world where testbeds can hardly achieve comparable sizes. Moreover, the type of insights which can be achieved is also different: simulation-based studies aim at the statistical performance analysis in generic scenarios. Experiments are, instead, typically location-specific. The comparison of results is therefore challenging. The aim of this project is to develop experimental tools and methodologies which can lead to a better integration of simulations and experimental studies in the validation process of wireless concepts.

The research context, for experimental activities in this thesis, is the management of future 5G mobile networks in local area. In this respect the study of indoor network deployments is considered of primary importance. Specific research objectives are:

- *Path loss characterization* - Empirically determining the path loss over multiple wireless links provides detailed information for determining the signal and interference characteristics in the network.
- *Analysis of Network Topology* - The positioning of network nodes is typically affected by the environment characteristics of practical building locations. Field trials allow to compare the network topology characteristics with common assumptions made in simulation.
- *Impact of dynamic Scenarios* - Time-varying phenomena in the deployment scenario (movement of objects in the environment, movement of the nodes) may have a non-negligible effect on the performance and long-term stability, of distributed decision-making schemes.

In the wide context of 5G, this project focuses primarily on the problem of interference management. In this respect, distributed FD-ICIC schemes have been selected as the main target for the experimental validation. Specific aspects analyzed in this thesis are:

- The interference characteristics over multiple links in practical indoor network deployments
- The overall network performance in realistic deployment conditions
- The analysis of system configuration parameters

As secondary objectives, the experimental tools developed in this project enable the analysis of other 5G network enhancements, such as interference rejection/alignment and distributed synchronization in time-scheduled communication systems.

1.4 Thesis Outline and Contributions

The structure of the thesis is presented in this section, highlighting the contribution of the discussion for every topic addressed.

Chapter 2 – Experimental validation of wireless concepts in local area

At first, the state-of-the-art and literature review about experimental activities with wireless concepts are discussed. The main objective is to highlight the fundamental aspects for the design and execution of experiments, by analyzing relevant research works in local area with hardware testbeds. Useful contributions have been identified in the fields of wireless sensor networks, CR and WiFi protocols. SDR platforms have been identified as a suitable tool for the development of research testbeds with wireless network concepts. Although the discussion of the state-of-the-art is present in every publication related to this PhD project, major contributions for this chapter have been taken from:

- Oscar Tonelli, Gilberto Berardinelli, Fernando Menezes Leitão Tavares, Andrea Fabio Cattoni, Petar Popovski, Troels Bundgaard Sørensen and Preben Mogensen “Real-world experimentation of distributed DSA network algorithms”, Book Chapter in *Evolution of Cognitive Networks and Self-Adaptive Communication Systems*, IGI global, 2013. [8].

Chapter 3 – Design of an SDR platform for wireless network testbeds

In this chapter are discussed the design requirements for a wireless network testbed in local area. A new framework for the development of SDR-based communication systems has been proposed in this thesis, and named ASGAR. ASGAR aims at enabling the implementation of reconfigurable communication systems as well

as providing integrated support for the management of large testbed infrastructures. All testbed configurations developed for the experiments, in this thesis, rely on ASGARD for the implementation of the communication system architecture. Initial evaluation work about the platform design and its performance has been published in:

- Oscar Tonelli, Gilberto Berardinelli, Andrea Fabio Cattoni, Troels Bundgaard Sørensen, Preben Mogensen, “Software architecture design for a dynamic spectrum allocation-enabled cognitive radio testbed”, *The 2011 European Signal Processing Conference (EUSIPCO)*, Barcelona, August 2011. [9].
- Gilberto Berardinelli, Per Zetterberg, Oscar Tonelli, Andrea Fabio Cattoni, Troels Bundgaard Sørensen, Preben Mogensen “An SDR architecture for OFDM transmission over USRP2 boards”, *Asilomar Conference on Signals, Systems and computers*, Pacific Grove - CA, November 2011. [10].

Further documentation about the ASGARD platform has been included in [8] as well as abstract contributions submitted to the workshops of the COST IC0902 Action.

Chapter 4 – Experimental methodology and practical execution aspects

The developed experimental methodology as well as the design and the execution of experiments are discussed in this chapter. The objective of the experiments is the performance validation of distributed network concepts in practical operating conditions. The main challenge in the experimental methodology is how to enable both the analysis of runtime execution aspects with the algorithms, as well as the large-scale evaluation of network topologies. In the thesis two distinct approaches are proposed, the *live execution* of concepts directly on the testbed hardware, and *hybrid-simulations* exploiting link path loss measurements from the field, in order to improve the accuracy of traditional simulation-based studies. Parts of the content of this chapter have been included in several of the publications related to this thesis ([12], [13], [8]).

Chapter 5 – A study of wireless links in indoor network deployments

This chapter describes the path loss measurement campaigns performed with the testbed in multiple indoor locations: office and open-area/mall-type. The objective of the campaigns was to collect link path loss information in real-life scenarios, providing input for the performance evaluation of resource allocation algorithms with hybrid simulations. The chapter analyzes the impact of path loss modeling and scenario geometry on the characteristics of random network deployments in the environment. A comparison with common simulation scenario models is also proposed highlighting similarities and limitations. Material from this chapter has been included in the paper:

- Oscar Tonelli, Ignacio Rodriguez, Gilberto Berardinelli, Andrea Fabio Cattoni, Jakob Lindbjerg Buthler, Troels Bundgaard Sørensen, Preben Mogensen “Validation of an Inter-Cell Interference Coordination Solution in Real-World Deployment Conditions”, *VTS Vehicular Technology Conference, IEEE*, Seoul, May 2014. [12].

Chapter 6 – Performance validation by means of experimental trials and measurements

In this chapter, the experimental approaches developed in the thesis are applied for the performance validation of distributed network concepts. An algorithm for **FD-ICIC** is the main target of the analysis, focusing on critical aspects for its execution as well as on its capabilities of coping with different network topologies and propagation environments. Live-execution experiments and hybrid simulations have been employed for the concept validation. [12] as well as the following publication relate to content of this chapter:

- Oscar Tonelli, Gilberto Berardinelli, Fernando Menezes Leitão Tavares Andrea Fabio Cattoni, Istvan Kovacs, Troels Bundgaard Sørensen, Petar Popovski, Preben Mogensen “Experimental validation of a distributed algorithm for dynamic spectrum access in local area networks”, *VTS Vehicular Technology Conference, IEEE*, Dresden, June 2013. [13]

Chapter 7 – Conclusions and future work

Final conclusions and recommendations for future works are drawn in this chapter. The experimental validation of novel concepts for wireless communication systems has enormous research potential; its full exploration requires however, continuous improvement of the experimental tools and practical methodologies.

Appendixes

In this thesis the testbed setup and execution approaches have been applied also for the initial experimental validation of other solutions for **5G** small cells deployments in local area. Activities with advanced receivers for Interference Rejection Combining (**IRC**) and distributed algorithm for the network synchronization have been included in Appendixes **A** and **B**. Related publications are:

- Gilberto Berardinelli, Jakob Lindbjerg Buthler, Fernando Menezes Leitão Tavares, Oscar Tonelli, Dereje Assefa, Farhood Hakhamaneshi, Troels Bundgaard Sørensen, Preben Mogensen “Distributed Synchronization of a testbed network with USRP N200 radio boards”, *Asilomar Conference on Signals, Systems and Computers*, Pacific Grove - CA, 2014. *Accepted for publication*. [15]

- Dereje A. Wassie, Gilberto Berardinelli, Fernando Menezes Leitão Tavares, Oscar Tonelli, Troels B. Sørensen and Preben Mogensen, “Experimental Evaluation of Interference Rejection Combining for 5G small cells”, *IEEE Wireless Communications and Networking Conference*, New Orleans -LA, 2015. *Submitted for publication*.

1.4.1 Other dissemination activities

In addition to the previously mentioned papers and book chapters, other publications and dissemination activities have been carried out during the time of this PhD thesis project:

- Claudio Sacchi, Oscar Tonelli, Andrea Fabio Cattoni, Yannick Le Moullec, “Implementation Aspects of a Flexible Frequency Spectrum Usage Algorithm for Cognitive OFDM Systems”, *Aerospace Conference, IEEE*, Big Sky - MT, March 2011.
- Gilberto Berardinelli, Fernando Menezes Leitão Tavares, Nurul Huda Mahmood, Oscar Tonelli, Andrea Fabio Cattoni, Troels Bundgaard Sørensen, Preben Mogensen “Distributed synchronization for Beyond 4G Indoor Femtocells”, *20th International Conference on Telecommunications (ICT)*, Morocco, May 2013.
- Andrea Fabio Cattoni, Jakob Lindbjerg Buthler, Oscar Tonelli, Luiz A. Da Silva, Joao Paulo Cruz Lopez Miranda, Paul Sutton, Floriana Loredana Crespi, Sergio Benco, Alberto Perotti, Daniel Riviello, “Designing a CR Test bed - Practical Issues”, in: *Cognitive Radio and Networking for Heterogeneous Wireless Networks: Recent Advances and Visions for the Future*. Springer-VS, 2014.
- Five abstract submission to the workshops of the COST IC0902 Action ”Cognitive Radio and Networking for Cooperative Coexistence of Heterogeneous Wireless Networks” from 2011 to 2013.
- Multiple live demonstrations with the testbed. In particular, 2 official reviews of the FP7 EU project “SAMURAI” (Bruxelles 2011, Sophia-Antipolis 2012). The 2nd International Workshop of the COST IC0902 Action (Barcelona, 2011) and a participation a the “Scandinavian workshop on testbed based wireless research” (Stockholm, 2013)

The work done in relation to the ASGARD software platform has been publicly released as open source software. The code and the documentation is available at website <http://asgard.lab.es.aau.dk>. The ASGARD software has been utilized

in academic projects at Aalborg University and the University of Trento (Italy), where remote lectures have been held for both bachelor and master-level students.

Experimental validation of wireless concepts in local area

2.1 Introduction

In wireless communications, experiments and measurement trials are typically used for the proof-of-concept of theoretical proposals or, alternatively, for the validation of simulation results and models. By surveying the literature it appears that the number and coverage of experimental activities varies considerably according to the specific research topic. Focusing on wireless applications for local area networks, major experimental work has been published for Wireless Sensor Networks ([WSN](#)), Wireless Multi-Hop Networks ([WMN](#)) and [CR](#). On the contrary, cellular solutions do not account for the same experimental coverage. The reasons for this are manifold. First, the deployment of a cellular infrastructure in local area has been disregarded in the past, because of technical difficulties and limited demand of such services. Secondly, the non-availability of low-complexity hardware support (as for the case, instead, of WiFi and sensor networks) discouraged the research efforts by the academia. A third element, possibly explaining the scarce literature about local area cellular network experiments, may relate to the business sensitivity of field trials and testbed prototypes for global market leaders in this area. The publication of early activities and results, in this sense, might have been discouraged.

In this thesis we focus on the analysis of distributed network algorithms for lo-

cal area cellular networks. This chapter presents an overview of literature works considered to be relevant for the thesis objectives independently on their original application background. In particular, the discussion will focus on the practical aspects related to the experimentation with network testbeds, the analysis of indoor environments, as well as on the design and development of experimental tools and methodologies.

2.2 Experimental activities in local area

Wireless applications in local area assume that network nodes are located in close proximity to the users —typically corresponding to indoor deployment scenarios. The operative environment is then characterized by wireless links with relatively short distances and nodes with reduced transmission power compared to outdoor applications. Examples of technology standards currently employed in local area are 802.11/WiFi, 802.5.4/ZigBee, as well as WiMAX, HSPA and LTE femtos. Despite competing technologies may adopt very different system architectures, from the research perspective all local area applications share one common challenge: the need of ensuring adequate signal coverage in presence of a complex propagation environment inside buildings. In this section, multiple experimental activities conducted in various operating scenarios are discussed, aiming at providing an insight about the impact of the indoor channel propagation on the network performance. In particular, aspects related to node topology, link connectivity and coverage range of the access points are considered of major interest.

One research area, which experienced experimental activities and measurement campaigns in local area, is the validation of simulation models for Mobile Ad-hoc NETworks (MANET). MANET, as well as mesh networks, adopt dynamic mechanisms to route the data across node configurations with variable topologies. Assessing the connectivity of wireless links in realistic deployment conditions is a major objective in this area because even a limited degree of inaccuracy in the prediction of inter-node link characteristics, may have a profound impact on the reliability of routing mechanisms and thus the network performance. In [16] a series of trials with 802.11 devices aim at the validation of the link models for the ns-2 system level simulator [17]. The role of shadowing propagation model parameters (e.g. path loss exponent and standard deviation) in the simulation of the received signal power on the links, is discussed. The study results show a direct relation between the values employed for the path loss exponent parameter and the accuracy in reproducing the actual link connectivity in a real network deployment. The path loss exponent can be tuned by comparing simulation results to multiple measurement trials. The optimal value, however, is extremely deployment-specific, thus exposing the practical limitations in directly transposing experimental insights to more general scenario conditions.

A similar analysis is derived by the work in [18] where experimental trials are considered for the validation of ad-hoc routing protocols in MANET. Like the previous article, also this contribution focuses on network applications based on 802.11 hardware. The performance results obtained from the experimental trials suggest, once more, that a proper tuning of the channel model parameters can lead to a more realistic description of the system behavior in simulation, but sensitive to the specific values selected for the parameters. A more accurate analysis of the system performance can be achieved by employing the direct information about the deployment scenario in the form of point-to-point link path loss values. The acquisition of such data is hindered, according to the authors, by the practical challenges related to the design and execution of the experiments.

The validation of simulation models through experiment trials is discussed also in [19]. Measurements from a testbed based on 802.11b/g hardware provided a quantitative analysis of the discrepancies between experiments and simulations in respect to critical Key Performance Indicator (KPI)s for WiFi mesh protocols (e.g. hops, transmission rate, routing stability). Moreover, from the result discussion it is established that the analysis of indoor network deployments in simulations is considerably less accurate, compared to the outdoor case, due to the complexity in modeling the indoor channel propagation.

Another experimental approach for the validation of simulation models of 802.11 systems is proposed in [20]. Multiple testbed nodes (i.e. based on laptop PCs equipped with 802.11 cards) have been utilized for the measurement of Received Signal Strength (RSS) in an indoor network deployment. The obtained RSS data has been then utilized for the calibration of simulation models for the prediction of SINR and packets reception. The same testbed, featuring 12 nodes, has been also utilized for the validation of the network performance in simulations. Results show that the updated simulation models can deliver an accuracy, in terms of throughput, in the order of 10% of error for the 85-th percentile of the evaluated links. Traditional simulation models were found to achieve a 10% of error at the 85-th percentile.

More recent contributions focusing on the refining of the 802.11 PHY modeling have been published in [21] and [22]. In these papers a series of experimental trials are performed in an indoor office location at several times of the day also considering human presence in the environment. In [21] an updated model for the achievable Frame Error Rate (FER) on the links is derived on the base of the measurements conducted in both static and dynamic environment conditions. In [22] the previous analysis is integrated with considerations relating to the hardware sensitivity, and other parameters critical for the simulation of UDP and TCP transport protocols.

Other experimental activities with local area network deployments have been carried out in the context of the creation of Radio Environment Maps (REM) as

Table 2.1: Summary of major experimental activities with local area wireless networks cited in this chapter

Research area	Related literature cited in this chapter
Ad-hoc/Mesh networks	[16], [18], [19], [23], [24]
Validation of simulation models	[19], [20], [21], [22], [25]
Analysis of indoor propagation environments	[26], [27], [28], [29]
Femtocells	[30], [31], [32]

support to the Radio Resource Management (RRM). REM provide a detailed description of the radio environment by acquiring spectrum sensing information from multiple network nodes. In [26] a testbed featuring 80+ devices (i.e. employing different hardware solutions) is utilized for investigating the effects of indoor propagation on the acquisition of REM information. A series of experiments focused on the accuracy of classical propagation models (i.e. based on link distance and wall crossings) for the prediction of received signal power on the links. A first trial was conducted in a dynamic office propagation environment with stationary nodes. The obtained results show that basic propagation models have critical difficulties in predicting the effect of indoor multipath and hardware non-idealities. Errors in terms of received power estimates may range from 3.8 to 6.8 dB depending on the specific hardware. A second trial with a similar testbed setup also considered a moving transmitter. The experiment helped establishing that the complex variations of the indoor channel propagation in time, pose several challenges to the long term reliability of the acquired REM information. Exploiting the same set of spectrum power measurements, in [27] the performance validation of two algorithms for the modeling of the network radio activity patterns (ON/OFF states) is proposed.

In [28], a 60 wireless sensors testbed is used for the experimental analysis of spatial statistics techniques for the coverage prediction of wireless networks in indoor environments. Readings from the testbed are utilized as input to refine statistical models; the obtained result show that an accuracy with errors in the range of 3.1-6.9 dB can be achieved.

Experimental activities with indoor femtocell networks are presented in [30]. This contribution focuses on mobility aspects by analyzing the movements of pedestrian users in the environment. Experiments have been performed with a testbed formed by 6 femto access points. The setup has been deployed across multiple floors in a building, and operates in a dedicated spectrum band thus free of interference from the outdoor macro layer. The network performance is evaluated in terms of handoff behavior and data throughput. The obtained results highlight the critical

impact of users speed variations for determining the handoff location in an indoor environment (i.e. handoff locations may vary up to 70% of the cell radius), as well as the difficulties in modeling these phenomena in simulations.

A particular experience, related to the interference mitigation in femtocells, is described in [31]. In this contribution, a centralized approach for the resource management among for Orthogonal Frequency Division Multiple Access (OFDMA)-based femtocells in local area is proposed and experimentally validated with a WiMAX testbed. The experimental setup consists of 4 femtocells deployed in an indoor enterprise environment. The experimental results show significant gains, in terms of throughput, obtained by the proposed approach in respect to conventional resource management solutions. An extension of this work in [32], focuses on the impact of poor inter-cell synchronization on the performance of the resource management scheme. A setup with 3 WiMAX femtocells setup is considered in the analysis. The obtained experimental results indicates that although good frame synchronization is essential for achieving the best throughput performance with the algorithm, the resource isolation in the frequency-domain can be beneficial even in poor synchronization conditions.

A different approach to the experimental validation of wireless concepts has been adopted by the developers of the ORBIT testbed at WINLAB, Rutgers University [23]. The ORBIT testbed is formed by a regular grid of 20x20 multi-radio wireless nodes located in dedicated laboratory facilities, which can be configured to reproduce various topology configurations. Of particular interest is the work done in [29] aiming at recreating the link Signal to Noise Ratio (SNR) conditions of real-world wireless deployments onto the laboratory grid of ORBIT. The starting assumptions of the authors is that the average SNR values experienced on the wireless links of a real-world network can be reproduced in a laboratory grid, by properly selecting the position of nodes and adjusting their transmission power. In the cited paper, a testbed configuration employing multiple APs, noise sources and receive terminals is able to reproduce the real link conditions with SNR range up to 57 dB. The authors define two different techniques for mapping the deployment of AP-based networks and mesh configurations. The proposed experimental approach aims at supporting highly reproducible trials in contrast to the traditional field trials. The ORBIT setup enabled to evaluate network deployments featuring up to 50 nodes.

In ad-hoc and mesh networks, the accurate prediction of network links connectivity constitutes the main motivation for the execution of experiments. According to the literature, the modeling of wireless links is especially challenging in indoor environments, mostly due to the multipath effect. Poor link modeling affects the capabilities of simulation-based studies of accurately reproducing performance indicators such as SINR the data rates on the links, signal detection probability, APs coverage range and eventually, the interference levels in the network. Calibrated simulation models have been proposed in many literature works as a

solution for improving the accuracy, for example, of path loss estimations. As a general tendency, however, their applicability is mostly confined to the specific building scenarios where the original measurements have been performed. Many of the experimental experiences discussed in this chapter rely on 802.11-based systems. In this context, the presence of Carrier Sense Multiple Access - Collision Avoidance (CSMA/CA) mechanisms impedes the concurrent transmissions by multiple nodes. The characterization of the interference, in relation to the network deployment, is then disregarded in most of these works.

2.3 Experimental activities with Cognitive Radios

Another research field characterized by abundant effort into the experimental approach is CR. Differently from the previously cited works with ad-hoc and mesh networks, most of CR studies do not refer to specific radio standards (although the 802.22 standard is often considered as a reference) and customized PHY and MAC solutions are commonly adopted. The CR paradigm moreover, is born [33] in tight connection with the concept of SDR. Almost all experimental prototypes and testbeds proposed in literature are based on SDR solutions. The design elements of SDR platforms will be the subject of a detailed discussion in the next chapter. In this section we focus on significant experiences with CR concepts considered to be relevant to the development of devices relying on the support of reconfigurable protocol stacks and autonomous decision-making features.

In the past years, the main field of application for CR concepts can be certainly identified in the *opportunistic access to the spectrum* [4], in both military and civil applications. In particular, the exploitation of underutilized licensed spectrum bands —e.g. the case of TV white spaces— generated a considerable amount of works which also included extensive experimental analysis. The real-world validation of CR concepts has been immediately perceived as an indispensable activity by the research community, because the tight regulatory requirements for opportunistic spectrum applications, in terms of reliability and protection of primary users, demanded high confidence levels in the system evaluation that only experiments could provide. System prototyping and field testing in CR focused mainly over four research aspects: spectrum sensing [34], DSA [4], rendez-vous mechanisms [35] and design of reconfigurable communication protocol stacks.

In an opportunistic network, low-priority users should be able to detect transmission opportunities across the available spectrum and exploit them to establish communication links transparent to the primary applications. In this context, techniques for the efficient sensing of the spectrum as well as the reliable identification of transmissions are extremely important. In [39] a rendez-vous mechanism for the establishment of opportunistic communications has been proposed and

Table 2.2: Summary of major experimental activities with CR cited in this chapter.

Research area	Related literature cited in this chapter
Spectrum Sensing	[36], [37]
Spectrum Access	[38], [25]
Rendez-vous mechanisms	[39]

experimentally verified. The described approach relies on the detection of cyclostationary signatures embedded into the transmitted signal by the secondary user. In the paper, a testbed setup based on SDR hardware is utilized for the concept validation. The design of the proposed software transceiver is also reported.

The detection of cyclostationary signatures is the objective also of the work done in [36]. In this case, the experimental validation of a detection algorithm is integrated by an analysis on the system design requirements as, for example, the size of the Fast Fourier Transform (FFT) required by the signal processing. The work done in [37] focuses instead on the problem of spectrum sensing. In particular, the experimental validation of cooperative sensing algorithms over a testbed network is addressed. Cooperative sensing schemes are distributed mechanisms aiming at improving the overall sensing information available at the nodes, by merging measurements acquired by multiple devices at the same time. A testbed employing 802.15.4-compliant devices has been developed with the objective of validating the sensing algorithms over a range of different signal detection probability conditions. In order to acquire such experimental data, multiple trials with variable topology configurations have been devised. A very interesting contribution of [37] is a discussion on how to reproduce specific deployment scenario characteristics with a testbed. In this paper, for example, the analysis focuses on how to obtain a pre-defined detection probability in the experiments.

In [38] another experience focusing on the validation of opportunistic spectrum access mechanism is reported. In this paper a CR solution based on Genetic Algorithms (GA) is proposed. The design of the system aims at enabling the optimization of the communication parameters of the transmitting nodes (i.e. transmission power, modulation order, choice of frequency channel) such that temporarily unoccupied spectrum bands can be exploited for communication, even in low SINR conditions. The experimental setup aims at proving the practical feasibility of the system implementation also verifying the reliability of runtime execution aspects such as the convergence time (in terms of iterations) of the decision-making algorithm.

A problem of coexistence between two different opportunistic network solutions is described in [25]: a series of experimental trials is conducted with two independent

testbeds which are jointly operating in the same spectrum band. The employed testbeds feature the same hardware and RF setup while implementing two different SDR transceiver architectures. The results included in the paper confirm the capabilities of the two systems in enabling concurrent transmissions and thus co-exist. This experience provides a practical proof of the flexibility of SDR solutions in supporting multiple system implementations and thus being an enabler for the fast-prototyping and experimental validation of wireless communication concepts.

A comprehensive summary of major demonstrational and experimental activities with CR can be found in [6]. The paper proposes an interesting analysis about upcoming challenges and current limitations of the experimental work. Among the many considerations provided, the following are relevant for this thesis' discussion:

- Most of experiments relate to DSA applications
- Open hardware platforms and open-source SDR development kits are the reference tools for the realization of testbeds
- Orthogonal Frequency Division Multiplexing (OFDM) is the typical waveform of choice
- Sensing mechanisms rely in most of cases on energy detection which suffer from poor accuracy at low SNR.
- Most testbeds employ few nodes, rarely exceeding single digit numbers
- Single-link and centralized network management solutions are the typical target of the experiments. Very limited is the coverage of large-scale and distributed network applications.
- The academia dominate the generation of experimental publications and the development of prototypes.

Eventually, reprising the authors' analysis in the paper, it is possible to conclude that most of the CR experimental works presented in literature suffer of limited network focus, small testbed scale and lack of out-of-the-lab experiences.

2.4 Testbeds and trials

The characteristics of the testbeds configurations employed in the trials are of fundamental importance for ensuring the desired outcome of experiments. The practical challenges related to the setup and management of such testbeds, moreover, have a decisive impact in defining the complexity and coverage of the experimental analysis. In this section, the design elements of testbeds utilized in

literature works are discussed, aiming at highlighting potential critical aspects for the validation of distributed network concepts in local area.

2.4.1 Type of testbeds

On the basis of the experimental objectives pursued, different types of wireless testbeds exist. Reviewing the works presented in literature, e.g. those discussed in sections 2.2 and 2.3, three major categories can be identified. Distinctions relate to the type of experimental insight provided, the complexity in the system design, and the complexity in the deployment management. In Figure 2.1 a visual representation of such categories is proposed, distinguishing between *channel-oriented* and *protocol-oriented (PHY/Network)* testbed configurations.

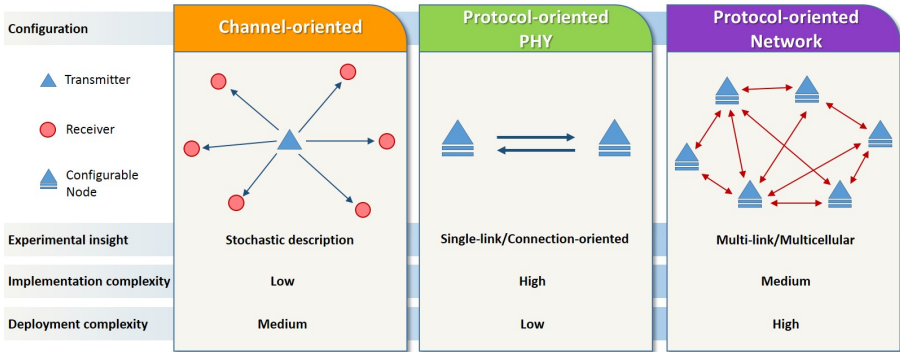

Fig. 2.1: General types of testbed configurations

Channel-oriented testbeds target primarily the investigation of signal propagation aspects and single-link characteristics which relate to the transmission of probing signals towards measurement terminals. These type of configurations are designed for the detailed analysis of physical phenomena thus typically employing specialized measurement devices (e.g. signal generators, spectrum analyzers, wideband channel sounders) for high-precision results. The number of measuring terminals and/or measured locations is typically large in respect to the number of probes/-transmitters. Due to the characteristics of the equipment, the devices employed in these kind of testbeds have specialized purposes which are typically not interchangeable.

The second category of testbeds focuses on the analysis of physical layer applications. In these cases, the transceiver design and the support for computational-intensive signal processing tasks is typically the main concern. Examples in this sense are testbed for multiple-antenna solutions (e.g. for multi-point transmission

or interference alignment), advanced coding features, or fast-response medium access protocols based on carrier sensing. Due to the complexity (and costs) of the hardware/software design, these testbeds are often characterized by a very limited number of nodes (i.e. from 2 to 3 in most of the cases). In this context, the experimental focus is typically on the single-link.

The third category relates, instead, to testbeds with a focus on network-level communication aspects. This type of configurations aim at the performance evaluation of protocols (i.e. routing protocols, management of network resources) in large network configurations. In this context, the objective of the experiments is typically to obtain a multi-link or multi-cellular insight about the system performance. The network topology and deployment scenarios are also of major importance in the experiments. In comparison to physical layer oriented configurations, the requirements for the transceivers design may be more relaxed. Given the focus on the evaluation of large-scale network aspects, these type of testbeds necessarily employ a large number of nodes. The management of the deployments in the trials is, hence, particularly challenging. In this thesis the research focus is on distributed mechanisms for local area networks. The developed testbed configurations, later described in the next chapters, can be then considered as part of the network-oriented category.

2.4.2 Hardware/Software solutions

The design of testbeds must take into account several aspects which may range from the hardware RF support and the mobility of the terminals, to the practical deployment issues in real building/scenarios. In the context of a literature survey for multihop wireless networks, major challenges for the design of network testbeds have been discussed in [40]. Most of the considerations done in this article can be extended from multihop systems also to other local area wireless applications. The identified challenges are:

- *Cost* – The setup of large testbed infrastructures can be very costly. Commercial hardware products may constitute an affordable alternative to custom made solutions. A trade-off typically exists, between costs and the hardware quality and feature support (e.g. sensitivity of the RF components, configurability of the firmware).
- *Practical management* – The testbed management comprises the hardware deployment and configuration, the monitoring of experiments and the maintenance of the equipment. Management of large testbeds requires remote control and communication solutions.
- *Design of experiments* – The definition of an experiment trial articulates over several steps. Examples relate to the configuration of nodes topology,

the configuration of high-layer applications (i.e. generation of data traffic for the experiments), the configuration of the mobility of nodes and the control of the runtime execution of the trials.

- *Experiment Analysis* – The analysis of the experiments results requires tools for the collection of data traces, the aggregation of data from multiple sources, the data filtering and visualization.
- *Applicability* – Ideally the testbed should enable the verification of multiple communication protocols. The testing of different design solutions at [MAC](#) and [PHY](#) layers can be however hindered in commercial devices, by a limited access to the firmware. In respect to this problem, fully-programmable [SDR](#) solutions may provide an attractive alternative.
- *Repeatability* – The space and time variations of channel propagation conditions makes hard to achieve the repeatability of the experimental trials. Controlled environments as for example anechoic chambers or dedicated laboratory facilities could provide a solution. The trade-off between realism and repeatability should be however always considered.

The characteristics of the specific equipment employed in the experimental trials typically depend on the communication standard of reference or, alternatively, on the communication aspects targeted by the experimentation. A major distinction can be done between testbeds which rely on commercially available products (i.e. devices providing a full implementation of a communication protocol stack such as 802.11 or 802.15.4 interfaces), and those featuring customized solutions where a partial – or radically new – system implementation is considered.

Most of the experimental work about ad-hoc routing protocols and mesh networks targets WiFi-based applications. The testbeds employed in the experiments typically exploit commercial devices such as 802.11 access points, relays, and a great variety of user terminals. 802.11 chipsets are commercially available with multiple interface formats (i.e. PCMCIA, PCI, mini-PCI, USB, etc.). Their integration with PC and embedded solutions is usually a minor issue thus making the development of experimental applications accessible to non-expert users. In this context the development of novel communication features is typically seen as an extension of the existing protocol stack. From the testbed development perspective the implementation of new design elements depends on the hardware support in terms of firmware reconfigurability and the availability of software Application Programming Interfaces ([API](#)) in the device drivers.

A detailed description of the design challenges for a [WLAN](#) mesh testbed is provided in [24]. A system architecture which expands the original capabilities of an off-the-shelf WiFi chipset is described. The proposed design solution integrates the existing hardware drivers with software components running on an embedded

Linux platform. A simplified scheme of the architecture is reported in Figure 2.2: in order to reduce the complexity of the implementation process, the extended communication functionalities (i.e. here generalized by the Decision Making unit) are developed as user-space daemons – software processes running in the background of the Operating System (OS) – while only time critical functions, requiring low-latency access to the hardware resources, are implemented as OS kernel modules. The original Network Interface Controller (NIC) drivers typically provide access to the TX and RX streams (TX, RX handlers) to and from the hardware. Separate flows for the user data and control information can be achieved by exploiting both OS native interfaces with the NIC or by establishing ad-hoc connections between the kernel and user space. The scheme of Figure 2.2 is adapted from [24] in order to provide a more general reference for the prototype design, in presence of a commercial NICs with dedicated software drivers.

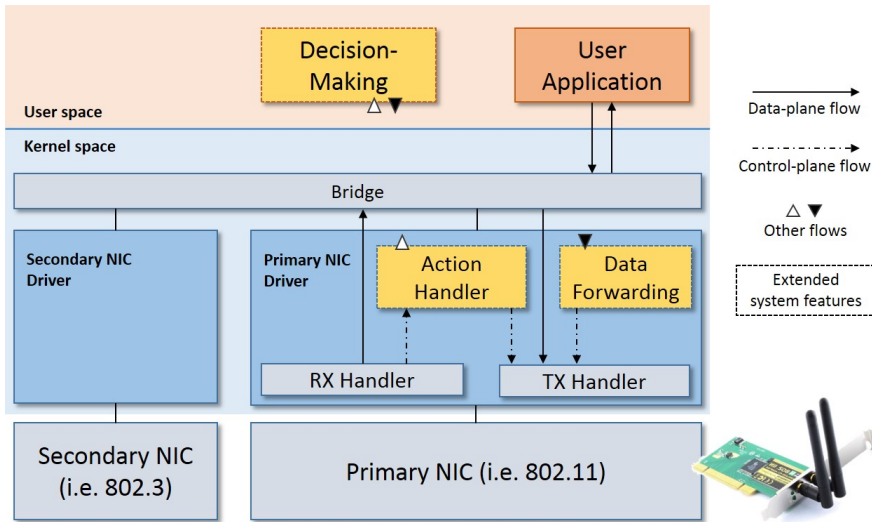

Fig. 2.2: The development of a system architecture extending the functionalities of existing technologies (i.e. 802.11) can be achieved by following a modular software design approach in both user and kernel space of the OS. The extended system features are integrated with the existing drivers controlling the NIC. Adapted from [24].

A testbed configuration relying on 802.11 hardware is discussed also in [41]. In this contribution a DSA mechanism for WiFi is derived by modifying the MAC layer implementation of a WiFi system. The necessary updates to the protocol stack are introduced by customizing an open-source driver implementation for Atheros 802.11 chipsets called Madwifi [42]. The developed system architecture is capable of interfacing with both hardware resources of the 802.11 wireless cards and the higher TCP/IP layers, thus providing support for a full communication protocol stack in Linux OS environment.

In [31] the realization of WiMAX femtocell nodes in the testbed, is achieved by using PicoChip platforms which provide a base implementation of a WiMAX-compliant master station architecture. The PicoChip platforms support the implementation of the algorithm features in the femtocells; the user terminals instead, are off-the-shelf commercial WiMAX USB dongles which do not allow any modification to their original firmware. The testbed of [31] requires a frame-level synchronization in order to enable a synchronized TDD transmission among the femtocells. Such challenging requirement in an indoor deployment is obtained by employing external GPS modules, attached to the master station boards, with antennas placed in proximity of the windows.

As briefly mentioned before, almost all CR experiments rely on solutions based on SDR hardware for the realization of the testbeds. A detailed discussion about the design of SDR platforms will be given in the next chapter. This section anticipates the main contributions that such platforms provide for the design and execution of experiments. A typical SDR configuration consists mainly of three components: an RF front-end, a baseband processing unit and a General Purpose Processor (GPP)-based host [43]. The basic concept of an SDR setup is that a communication protocol stack – from the user application, to the PHY transceiver chain – can be executed by means of software. A general scheme of the architecture of a testbed node relying on an SDR-based configuration with a host PC is depicted in Figure 2.2. The host and the SDR motherboard can be connected through interfaces such as Gigabit Ethernet, USB, PCI-express and others. The protocol stack implementation typically takes care of generating and receiving a stream of baseband samples that are then handled by the SDR hardware. Field Programmable Gate Array (FPGA) or Digital Signal Processor (DSP) resources can also be exploited for advanced signal processing purposes. From the perspective of the development of experimental prototypes, the main difference between an SDR-based configuration and a solution relying on commercial products, is that every detail of the communication system can be defined during the design phase and controlled during the execution. On the other hand, supporting such flexibility is typically paid in terms of implementation complexity and performance limitations of the signal processing. The software capabilities in managing high data-rate streams and low latencies are typically lower than an embedded hardware solution. Further considerations about the experimental tools supporting CR research can be found in [43].

One of the most utilized SDR platforms utilized in literature is the Universal Software Radio Peripheral (USRP) developed by Ettus [44]. The USRP is an FPGA-based motherboard which at the present day comes available with several specific configurations in terms of RF, processing and host interfacing capabilities. In literature, most of the works refer to USRP versions 1, 2 and N2XX. These configurations provide support for the baseband signal processing while a wide selection of RF front-ends, with various characteristics, can be inter-changed on the motherboard. The early popularity of the USRP boards is also greatly due

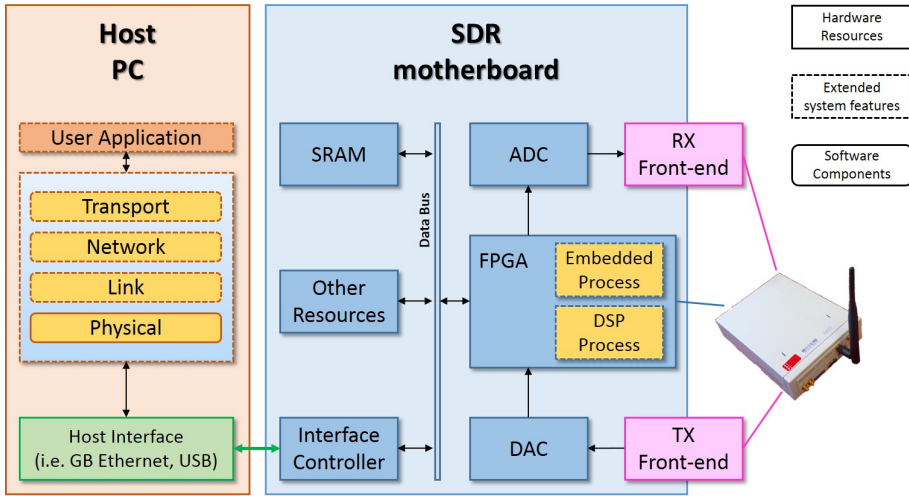

Fig. 2.3: General architecture of an SDR node. Adapted from [43].

to its easy interfacing with common host PC configuration through either USB or Gigabit Ethernet connections. A very interesting example of large, building-wide, testbed deployment exploiting the flexibility of the USRPs is presented in [45]. In this contribution is described the setup and management of the Cognitive Radio Network Testbed (CORNET) developed at the Virginia Tech Institute. CORNET features 48 independent CR nodes relying on USRP2 hardware. The peculiar characteristic of CORNET is that the GPP-based processing hosts of the SDR nodes are deployed separately from their RF front-ends. Hosts PCs are grouped on rack, in a dedicated server room in a building of the Virginia Tech campus, while the USRPs boards are located along the hallways of 4 different floors in the same building premises. The connection between the nodes and the hosts is provided by ethernet cables of type CAT6 which support a maximum length of 100 meters. The deployment approach adopted in CORNET eases considerably the setup of a large, permanent testbed infrastructure in a public building location. Moreover, the centralized placement of the host computers facilitates the control and maintenance of the testbed configuration. Among the drawbacks of this setup the fact that the "permanent" feature of the deployment prevented the placement of the nodes in restricted areas (i.e. closed rooms) of the building thus suggesting the deployment only in the hallways.

Developing SDR applications with the USRP from the user-space is made possible thanks to the open-source Universal Hardware Driver (UHD) which is constantly being updated and integrated with new features. The release of open-source drivers such as the UHD greatly fostered the development of software frameworks enabling the design of prototypes and experimental applications with the USRPs. By far,

the most popular of these is GNU Radio [46]. Details about GNU Radio and other software SDR platforms will be given in the next chapter. USRPs have been utilized in a plethora of experimental projects: here we recall the work done in [26], [39] and [47].

In its early stages of development the USRP has been mainly utilized as baseband support for full software implementation of SDR. Applications with demanding performance in terms, for example, of operational bandwidth and round-trip-time in the hardware response, typically exploited other platform solutions specifically designed for such purposes. A relevant example in literature is the Wireless open-Access Research Platform (WARP), developed at Rice University. WARP features large FPGA resources and a wide RF bandwidth (i.e. in the order of 40 MHz). Examples of experimental work conducted with the WARP platform can be found in [48] and [49]. Other platforms worth mentioning for their contribution to the experimental research with CR concepts are the Berkeley Emulation Engine 2 (BEE2) [50], SORA [51] and OpenAirInterface (OAI) [52]. All these solutions provide optimized signal processing capabilities able to handle high-rate data streams. Such characteristics are indispensable for the realization, for example, of multiple antenna applications. System design and implementation with these platform exploits customized software solutions which may involve FPGA, DSP, OS kernel programming, as well as relying on third-party software such as Matlab Simulink and Xilinx System Generator.

2.4.3 Metrics and Key Performance Indicators

The performance validation in experiments requires measurable metrics for a quantitative analysis of the obtained insights. Typical KPIs considered in wireless networks applications relate to throughput, signal quality, delays, error rates, failure rates (e.g. detection of signals), event probabilities and iterations required to the convergence of algorithms. Methods for the metrics data acquisition can differ depending on the characteristics of the employed testbed setup. Commercial wireless products, often enable the direct acquisition of fundamental KPIs at various points of the protocol stack. As described in [37], for example, information about Received Signal Strength Indicator (RSSI) can be extracted from 802.15.4-compliant sensor devices. Moreover, successful or corrupted transmissions of frames can be verified by examining the Cyclic Redundancy Check (CRC) field in the received frames by the terminals, thus deriving frame error rate (FER). Similar metrics are available also in 802.11 devices: in [20], RSS measurements are directly available from the testbed nodes as well as the FER. Given that the 802.11 MAC layer also implements a retry scheme for the automatic retransmission of corrupted frames, a Packet Error Rate (PER) metric which accounts for lost packets after the retransmission procedures can also be analyzed in the experiments. The throughput analysis in the previously cited experiences, takes

advantage from the full protocol stack implementation which enables the injection of real UDP and TCP traffic into the testbed. A link capacity analysis relying on UDP traffic is implemented also in [31] in the context of WiMAX downlink connections in a femtocells deployment.

Whenever commercial devices are not available, customized solutions for the acquisition of performance metrics are usually implemented. As in the case of many CR testbeds, application-specific implementations of the PHY layer enable the detailed analysis of the received signal characteristics and thus, in general, the measurements of signal quality and interference metrics (i.e. Reference Signal Signal Power (RSRP), SNR, SINR, etc.) which are often impossible to directly extract from commercial solutions. In [39], a customized implementation of the PHY transceiver, for example, enables the evaluation of the detection statistics related to cyclostationary signatures embedded into OFDM waveforms.

2.4.4 Execution of trials and testbed management

The setup and execution of trials with wireless network testbeds, is a complex activity with many practical aspects involved. Relevant examples are: the selection of the experimental scenario, the spatial deployment of the testbed nodes, the management of dynamic propagation environments, the management of multiple trials and the collection of data. In order to better understand the requirements of the testbed design as well as developing optimal execution methodologies for the experiments, it can be useful first to survey the literature for understanding how practical challenges have been tackled in the past.

The work done in [23] deals with the problem of repeatability of wireless experiments in practical deployment scenarios. In [23] the ORBIT testbed is presented, which consists of a regular grid of nodes, located in a dedicated laboratory facility, which can be used to reproduce the deployment of nodes from real network configurations. This kind of solution aims at guaranteeing the best control over the environment thus ensuring the reproducibility and repeatability of the experiments. Despite its advantages, the approach adopted in [23] is rather unique in literature. Most of experimental works favor indeed a higher level of realism towards repeatability, thus the majority of trials are conducted in real buildings.

In [22] an analysis of 802.11 systems performance is proposed, highlighting difference between the measured KPIs in static and dynamic environment propagation conditions. The experiments employ nine testbed nodes which are located across two consecutive floors in a tall building in Berlin, Germany. The nodes, divided in groups of five and four per floor, are deployed along the exterior walls of the building. The environment is characterized by both small rooms and open-space office areas. The analysis in static environment has been performed by running

the experiments during night hours when the environment could be free from the human presence. For the dynamic environment case, trials at different hours of the day and different days of the week have been considered. The reported results, in terms of RSS and frames detection statistics, show significant fluctuations in the dynamic scenario, comparing to the static case.

An example of utilization of multiple trials and aggregation of the obtained experimental data is reported in [20]. In the article, a testbed composed of 12 nodes is employed to analyze the system performance, in different network configurations considering a variable number of interferers. At first, a series of measurements, where all the nodes transmit on a round-robin basis, are conducted for the acquisition of link path loss information: a total of 132 path loss samples can be obtained from the considered 12-node setup. Secondly, additional 266 experiment trials have been executed to evaluate the achievable capacity on the network links, considering a number of interferers varying from 2 to 6. A discussion about the relation between the deployment cardinality and the amount of obtainable experimental data is provided in the paper. Said S the amount of different sets of nodes positions considered, T_n the number of interfering transmitters per trial and N_{tot} the total number of nodes in the testbed, the number of obtainable link data points is equal to [20]:

$$D_{tot} = ST_n(N_{tot} - T_n) \quad (2.1)$$

Many experimental contributions focusing on PHY and MAC communication aspects, are focused on the single link performance verification. In these cases a very limited number of nodes is typically employed in the testbeds and simple deployment configurations are usually considered. Examples of such experiences can be found in [53] and [24]. The described deployments consider the nodes to be placed at very short distances in a single room. No multiple deployments are reported. A completely opposite approach is instead pursued in experimental studies aiming at the characterization of the propagation environment. In these kind of experiences, as for example in [26], a much larger number of devices is typically employed. An important remark should be made however on the different role that such devices take in the testbed. In measurement-oriented trials, most of the testbed nodes are utilized in receive mode, while only very few transmitters – very often a single transmitter, or signal generator – are active during the trials. While this approach enables the acquisition of a large amount of information in relation to the channel propagation characteristics, the network dimension is typically absent with a very limited number of wireless links analyzed in relation to the total amount of devices deployed in the environment.

2.5 Summary

The literature review proposed in this chapter provided several elements of discussion in relation to practical tools and methodologies for the experimental validation of local area wireless concepts. Testbeds which can rely on commercially available products are typically easier to build (i.e. a larger number of nodes can be more easily employed) and the mobility of terminals is also facilitated. However, if the desired **KPIs** are not natively supported by the hardware, such type of data is typically impossible to retrieve. Customized testbed architectures, on the other hand, are more versatile but also much more complex to employ in large testbed configurations. **SDR**-based solutions represent an attractive option for testbeds providing great design flexibility for the development of prototypes and the execution of experiments. The analysis and validation of wireless concepts in local area is particularly challenging due to the difficulties in modeling accurately the indoor channel propagation. In this sense, almost all literature work considered in this chapter remark the importance of running experiments and acquire measurements in such deployment scenarios.

The setup and execution of experiments poses several challenges from the testbed design perspective as well as from the practical management of the trials. In the next chapter these aspects will be addressed in more detail, aiming at defining a suitable testbed platform and proper methodologies for the validation of distributed mechanisms in local area wireless networks.

Design of an SDR platform for wireless network testbeds

3.1 Introduction

Enabling the experimental analysis of wireless networks concepts requires a set of hardware and software tools, supporting the implementation, execution and numerical evaluation of the communication features of interest. The specific requirements of testbeds vary according to the objectives of the experimental research. For example, the investigation of **PHY**-related communication aspects typically demands testbed platforms with high signal processing capabilities, conversely the execution of network-oriented protocols makes the multi-link connectivity the priority.

In this thesis, the analysis of distributed network concepts focuses on solutions characterized by autonomous decision-making at the nodes and cross-layer system architectures. In this context, the testbed design aims at supporting reconfigurable protocol stacks and multiple parallel data-flows. In Chapter 2 it has been discussed how Software Defined Radio (**SDR**) platforms can provide optimal support for the system design, especially when targeting the development of research prototypes. In this chapter the execution requirements of distributed network testbeds are discussed, aiming at defining the design characteristics of an experimental platform based on **SDR**. Starting from the analysis of current state-of-the-art **SDR** research platforms, the **ASGARD** software has been developed and will be described as part

of the chapter.

3.2 Design aspects of SDR platforms

SDR solutions consists of mixed software-hardware configurations, where a GPP-based host and a motherboard featuring FPGA or DSP resources, can be jointly exploited for the system implementation. The design choice about the location of signal processing tasks over such architectures determines the performance capabilities as well as the design flexibility of the SDR platform. The data-transfer between the host and the SDR hardware occurs through multiple heterogeneous processing units and bus interfaces, each of those can generate delays and jitters. According to the analysis carried out in [54], such delays can add up to hundreds of milliseconds and thus incompatible with many PHY or MAC implementations (i.e. the Carrier Sense Multiple Access (CSMA) protocol in WiFi requires to react within few tens of microseconds). A detailed discussion about the challenges in the design of SDR architectures is provided in [55]. Two major categories of platforms are identified, according to the support provided to the signal processing (see also Figure 3.1):

- *NIC-PHY architectures* - Signal processing tasks are implemented directly on the FPGA or the DSP of the motherboard, thus enabling higher-rate data streams and reducing the latency in the transfer of data across the internal buffers and.
- *Host-PHY architectures* - The majority of processing is executed on the host side, thus enabling a greater control on the system architecture and the quick reconfiguration of the signal processing characteristics.

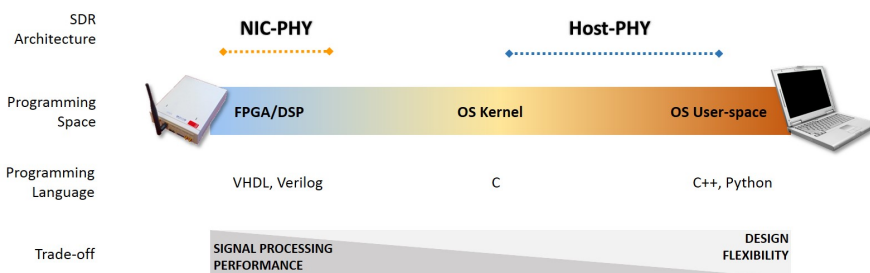

Fig. 3.1: Programming spaces for the development of SDR applications. **NIC-PHY** and **Host-PHY** architectures adopt a different distribution of the signal processing tasks over the available hardware/host resources.

NIC-PHY architectures aim at delivering the best signal processing capabilities for demanding system applications; for this reason, they often rely on customized hardware solutions capable to exploit the available resources at their best. Conversely, host-based platforms are often utilized in contexts where the processing requirements are more relaxed: commercial hardware represents then an attractive solution providing optimal trade-off between performance and usability. Among the **SDR** platforms cited in Section 2.4.2, **NIC-PHY** type of architectures are adopted, for example, by **BEE2** and **WARP**. The **USRP** boards, instead, are probably the most popular example of commercial devices utilized in **Host-PHY** configurations.

Host-PHY architectures can be further differentiated between **OS** kernel-space and **OS** user-space type of implementations. Kernel software processes have higher priority in accessing the **OS** hardware resources, in respect to user-space processes. User-space applications, instead, can be realized employing object-oriented programming languages (i.e. C++, Python). In this context, a kernel-based architecture allows to achieve lower latencies and higher throughput in the data-transfer. User-space implementations are typically more user-friendly and ease the fast-prototyping of complex system architectures. Referring again to the platforms cited in Section 2.4.2, **OAI** is an example of kernel-based **host-PHY** architecture, while the GNU Radio is implemented in the user-space.

The differences between **NIC-PHY** and **Host-PHY** architectures are not limited to design and execution of communication protocol stacks. Their characteristics also lead to different approaches to the overall management and maintenance of the testbed. An host-centric implementation, for example, is less dependent on the specific hardware employed. Assuming that proper drivers (i.e. software **APIs** allowing a user application to interface with the hardware) are available, a host-based architecture can be ported across different hardware configurations. In practice, this means that relying on a host-based architectures makes it easier to upgrade the testbed hardware or, alternatively, sharing the system implementation with other testbeds with similar characteristics.

3.3 Software Frameworks for SDR

In this section the design characteristics of **SDR** platforms based on **host-PHY** architectures are discussed. Given the host-centric nature of their implementation we will refer to these as *software platforms* or *software frameworks*. All platforms here described are released as open-source software. This aspect has been considered extremely important in this thesis —also remarked in other publications [6]— since the possibility of sharing the implementation details about the system design greatly favors the knowledge exchange and the scientific collaboration for the

improvement of concepts. Furthermore, open-source software platforms operating with commercial hardware solutions also enable the direct reproducibility of experiments across independent testbed deployments. The opportunities and challenges about testbeds federations of this kind are currently object of investigation and discussed in research projects [56] and publications.

The Open Source SCA Implementation Embedded (OSSIE) [57] is one of the first SDR software frameworks realized specifically for research and academic purposes. The objective of OSSIE is to enable the design of novel communication system architectures through intuitive interfaces and promoting code reusability. The OSSIE implementation is based on the Software Communications Architecture (SCA), which has been developed by the Joint Tactical Radio Systems (JTRS) program of the U.S. Defense Department with the aim of enhancing the interoperability and costs reduction of communication systems. SCA defines a radio application as a *waveform* which is implemented as the union of basic processing elements and interfaces. The main contribution of SCA is the definition of a *component-based* framework which by enforcing the encapsulation of processing tasks into container interfaces, it favors the development of modular software radio architectures. A modular approach to the design facilitates the reuse of the developed features and enables their portability across multiple hardware platforms. The OSSIE projects expands the functionalities of SCA, providing a complete software design environment comprising of components libraries and also a Graphical User Interface (GUI).

Probably the best-known software platform for SDR research purposes is GNU Radio [46]. The popularity of the GNU Radio software is due to its intuitive design framework, accessible also to non-experienced users, and its large diffusion as open-source software with a large community of contributors. From the architecture perspective, the development of GNU Radio followed the path of creation of a robust framework capable of ensuring –at any time– the compatibility of heterogeneous contributions from an open community of developers. One of the main objectives pursued in GNU Radio is the optimization of the system design for the manipulation of waveforms in PHY layer transceiver chains. The GNU Radio framework provides a series of basic software building blocks which enable the implementation of processing tasks according to a component-based design approach.

A simplified scheme of the architecture of an SDR application developed in GNU Radio is proposed in Figure 3.2. The structural element of a GNU Radio application is the *flow graph*. Processing components —named *blocks* in GNU Radio— can be sequentially connected in a flow graph by means of data buffers. Data flow through the graph of components, typically from a source towards a sink in an unidirectional way. The generation, the processing and the transfer of data are managed in a centralized fashion by the GNU Radio scheduler. The scheduler is part of the core GNU Radio framework and is typically transparent to the

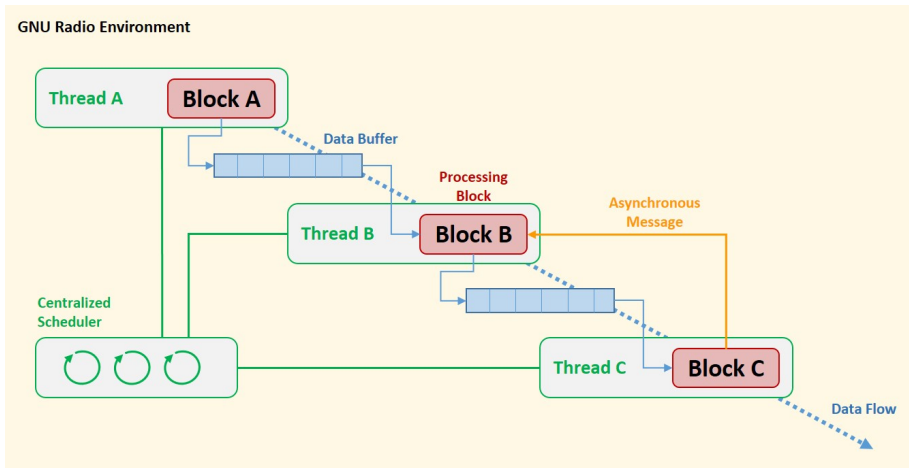

Fig. 3.2: Flow graph architecture of processing components as in GNU Radio. The centralized scheduler manages the execution of the block threads thus controlling the generation, processing and output of data in the graph. Buffers enable the directional data stream while asynchronous messages can be forwarded to upstream blocks.

user. Every block in the flow graph runs as an independent *thread* of execution (i.e. a set of instructions that can be managed independently by the OS), whose execution is supervised by the GNU Radio scheduler which determines when the block’s `work()` function (i.e. the software function implementing the actual data processing) is called. In GNU Radio shared buffers —featuring shared memory pointers to a common memory locations— are the main elements supporting the inter-block data passing.

The GNU Radio framework was originally conceived to manage linear and uni-directional flow graphs, as typically occurs in transceiver chains at PHY level. In order to support higher-layer communication protocols where data and control inputs may flow in different directions, mechanisms for the “upstream” and asynchronous data passing have been also recently introduced. The centralized management of processing threads allows to simplify the system implementation allowing the user to neglect several aspects related to threads synchronization and safe access to the memory. Additionally, the centralized control of data generation, computation, and transfer, enables the optimization of the data processing, particularly important for the performance of PHY transceivers. One limitation of the GNU Radio framework relates to the runtime reconfigurability of the graph architecture. In order to modify the graph connections, the execution of the application must be halted and then restarted. The runtime reconfigurability is an extremely important feature for cognitive radio applications where decision-making units may require to re-define the system behavior. Other frameworks have been developed with this in mind.

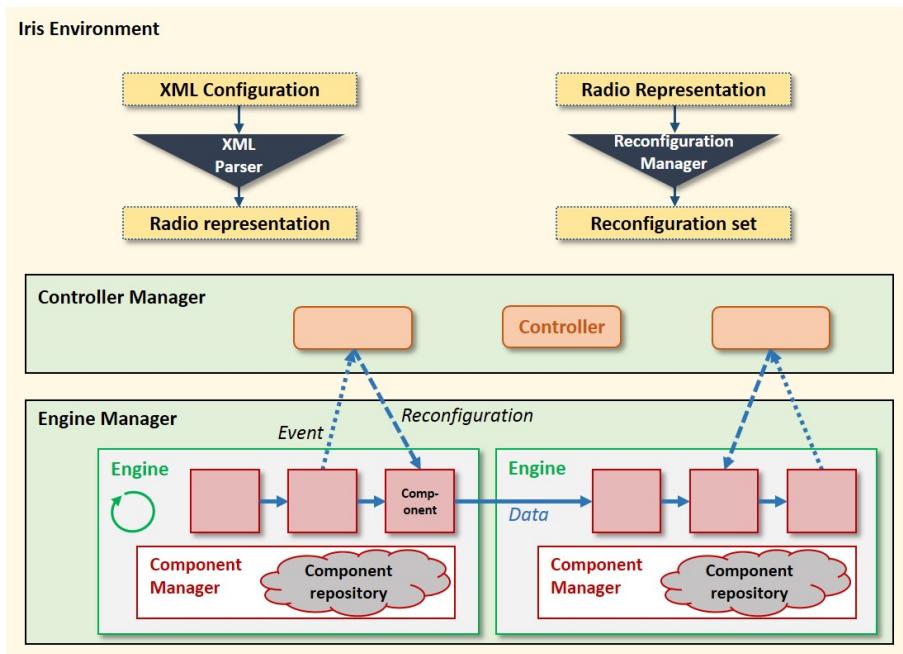

Fig. 3.3: Elements of the Iris framework enabling the design and execution of a reconfigurable system architecture. Modified from [58]

The Iris software platform [58] has been developed at Trinity College Dublin, aiming at providing specific support for reconfigurability. Iris is a component-based framework which aims at supporting the runtime reconfigurability of the flow graph, by adopting a versatile management of threads and events in the system. An overview of the Iris architecture is given in Figure 3.3. An important aspect of Iris is the separation, in terms of software design objects, between the signal processing operations and the threads of execution. Differently from the GNU Radio architecture, in Iris the basic processing blocks – called **components** – are not assigned each to individual threads, but rather they are managed by another software abstraction named **engine**. A single engine control the execution of multiple components at the same time within a thread, thus fully controlling the streaming of data between such components. The reconfigurability of the system architecture is obtained in Iris by means of a third building element named **controller**. A controller is an object, external to the flow graph, which is capable of reacting to **events** generated by components. Controllers run independently from components and can trigger their reconfiguration. Event messages generated by the components can also carry data, thus making the controllers a possible container for decision-making units in cognitive applications. In addition, similarly to GNU Radio also Iris support a full XML-based definition of the flow graph, which can be loaded during the system initialization. The development philosophy

adopted in Iris is particularly interesting because it extends the modular design approach from the processing tasks of an SDR architecture (i.e. encapsulation of coherent processing operations), to its behavioral features (i.e. encapsulation of execution routines and system reconfiguration). This shift in the design approach slightly increases the system implementation complexity, however, it also opens a wider range of possibilities in the architecture definition, enabling to overcome the model based on uni-directional flow graphs.

3.4 Design requirements for a distributed network testbed in local area

Almost all previously mentioned software platforms have been conceived with the support of the PHY layer in mind. The Iris platform introduced novel design elements which first go into the direction of supporting complex flow-graphs and network-oriented applications. However, no significant experimental activities with large network testbeds have been yet published in literature. The reason behind the difficulties in performing experiments at network level with current SDR platforms is that the full implementation of protocol-stacks is generally complex and extremely time consuming. Despite the previously described software abstractions enabling the feature encapsulation and re-utilization, the implementation of novel high-level protocols requires in principle all the underlying functionalities to be realized as means of processing blocks, buffers and controllers. The implementation details of the PHY layer may not be of primary importance to the researcher interested in network-level applications (e.g. the evaluation of RRM algorithms). The large effort required for the realization of an entire protocol stack may not be affordable in a research project. In this thesis, the realization of a testbed for distributed network applications takes into account such practical aspects.

A well-defined SDR framework facilitates the design of a communication system architecture allowing the developer to focus on the research aspects of interest, while hiding undesired complexity. A component-based design approach reaches these objectives favoring encapsulation and enabling to describe a system implementation as the union of basic building blocks. The characteristics of basic components, and other interfaces in the framework, define an implicit set of rules which determines what type of connections can be established, how the processing is executed and which data types can be employed in the system. Stricter design rules can help in simplifying the management of SDR applications preventing, for example, the creation of unstable configurations which may fail during runtime execution. While tight framework restrictions may have clear advantages in certain circumstances, on the other hand they also limit the design possibilities for novel communication solutions.

The design of concepts at the higher layers in the protocol stack, requires a shift in platform support from solutions for the efficient data processing, towards the management of abstract data-types and multiple data flows. In this respect, the evolution of the design capabilities of an SDR framework should enable a greater control by the developer over the threads scheduling, the creation of data classes, and the management of connections in a flow-graph. A software framework supporting the design of novel communication architectures should hence have a versatile, swiss-knife approach which allows every time to adapt the required design strategy. Furthermore, contrary to the industrial production or design where product specifications need to be defined in advance and be consistent end-to-end, experimental-research activities are typically incremental and iterative processes. A tool specifically conceived for research purposes should enable an agile revision of the implemented features at every stage of the project development.

Finally, another aspect particularly relevant for the execution of network-oriented experiments is the remote and centralized control of the testbed. During the experimental trials the nodes may be required to act in a synchronous and/or coherent manner. In an SDR context this means to control the execution of the system application which runs on every individual remote host. In distributed network experiments the testbed nodes are typically scattered across building facilities, thus a testbed backhaul infrastructure must be setup in order to manage and distribute control messages. The same problem of remote and centralized access to the testbed applies also to the acquisition of experimental data generated by the nodes.

The desired characteristics for a research-oriented SDR platforms, enabling the investigation of distributed wireless concepts, can then be summarized as follows:

- Enabling encapsulation and reuse of features through a component-based architecture.
- Increasing the developer control over threads scheduling and data-flows.
- Supporting reconfigurable architectures.
- Supporting customized data classes and objects.
- Provide native support to remote and centralized testbed management operations.

3.5 The ASGARD software framework

The ASGARD software framework has been developed in this project, aiming at creating a lightweight design platform for the realization of wireless communication

testbeds based on [SDR](#). The main idea behind the ASGARD concept is to enable the fast-prototyping of research concepts by combining the usability of component-based development tools with minimal restrictions to the design of flow-graphs. In ASGARD, software interfaces have been designed allowing the developer to create customized solutions for the data-transfer and management of execution flows. From a software perspective, the ASGARD framework consists of multiple shared libraries, written in C++, for Linux [OS](#).

The general architecture of the ASGARD framework is depicted in [Figure 3.4](#). A generic [SDR](#) application (i.e. an application controlling for example the execution of a node in the testbed) is implemented in ASGARD by means of three main software abstractions: *Application*, *AsgardSystem* and the building elements of the *Core Library*. An ASGARD *Application* is a user-space process directly managed by the host [OS](#), which can access the [SDR](#) hardware resources through the host physical interfaces (e.g. ethernet,USB). A communication system architecture is defined within an ASGARD Application by encapsulating all the required design elements within a high-level software container named *AsgardSystem*. All the basic building components in ASGARD —managing the fundamental system tasks, such as data processing, data transfer and threads execution— are part of a shared library named ASGARD *Core*. The implementation of the elements in the Core library depends on several third-party libraries which should be installed in the host together with ASGARD. Such libraries, including for example BOOST, IT++, Poco, Intel Threading Building Blocks, provide support to mathematical operations and facilitate the interfacing with the [OS](#) in respect to memory management and access to the network resources. The [SDR](#) hardware drivers are also linked to ASGARD as external libraries. The ASGARD framework, is released as open-source code. All linked libraries are as well open-source, thus enabling the free utilization of the framework for research and academic purposes.

When approaching the design of a communication system, three aspects are of major interest:

- The implementation of the data processing
- The definition of time execution requirements for the processing routines (e.g. the periodicity of frame based operations)
- The connections between the system elements enabling the data-transfer and the control of the configuration.

The design approach in ASGARD is to handle such aspects in a modular fashion, supporting encapsulation for complexity reduction and re-usability purposes. In the ASGARD Core Library, specialized software objects have been introduced aiming at enabling a "behavioral" design approach of an [SDR](#) application where

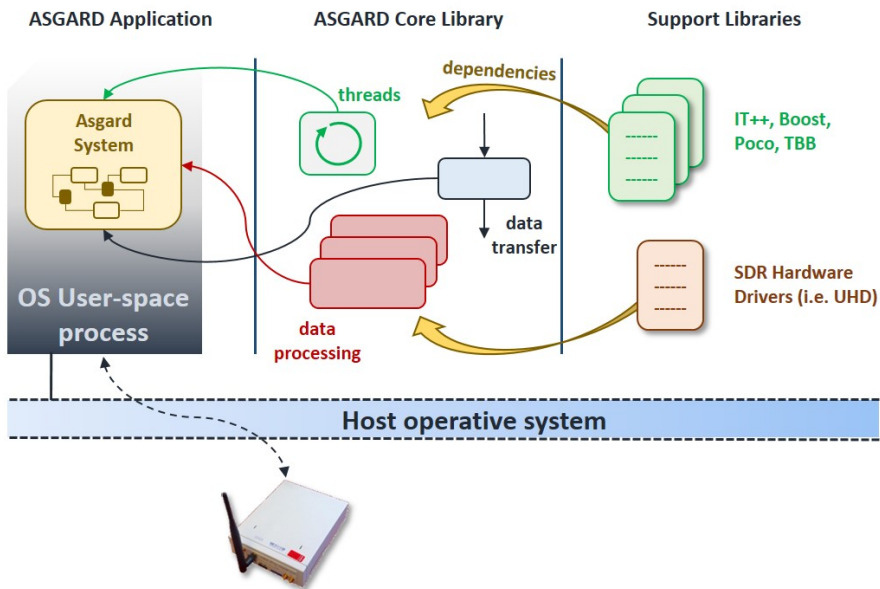

Fig. 3.4: Structure of the ASgard software framework. The basic building components of the ASgard Core library exploit a number of supporting third-party libraries.

developers can map data-flows and execution routines onto a set of basic software objects. This approach aims at facilitating the realization of higher-layer (e.g. RRM) communication concepts where multi-directional data flows may hinder the system design. In the remaining of this chapter the details about the software implementation of the ASgard building elements are discussed.

3.5.1 Definition of a processing task

A generic data processing task in ASgard is defined inside a class object container named **Component**. The purpose of a **Component** is to group coherent and atomic operations over the data and enable the re-usability of features. A **Component** is a multi-purpose object which can be utilized to define data sources, data sinks, processing operations (e.g. filters, encoders, decoders, modulators), timers and also decision-making units. The structure of a generic ASgard **Component** is depicted in Figure 3.5.

The core of the **Component** class object is the **Do()** method. Within a **Do()** method, a developer can specify the sequence of instructions that the **Component** will execute during the runtime. The **Component** is non-threaded object thus the execution

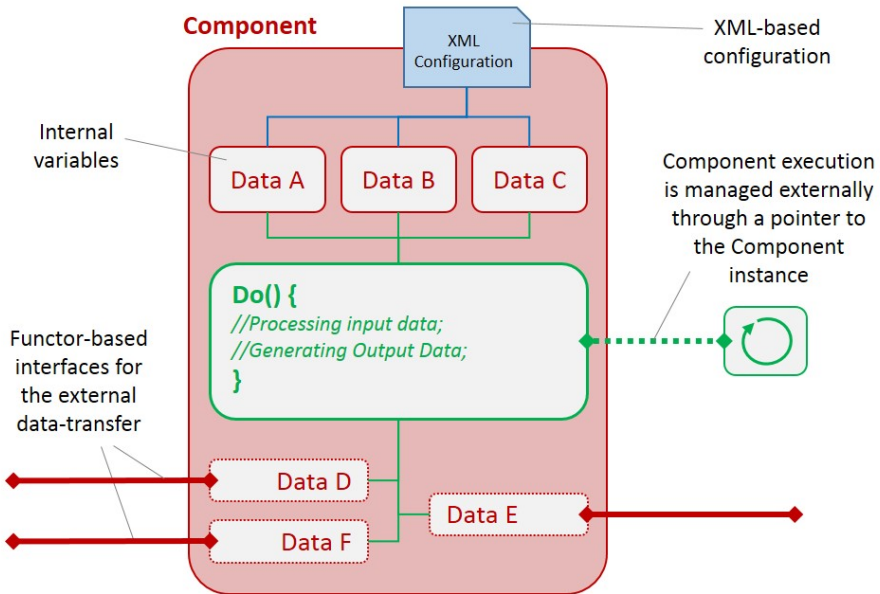

Fig. 3.5: Structure of an ASGARD Component. The Component supports an XML-based configuration of its internal parameters. The execution of the main *Do()* method is controlled externally. Flexible communication interfaces enable the data transfer input and output.

of its operations depends on an external software element which will be described later in more detail, in Section 3.5.2. **Components** can handle configuration parameters and local memory objects by defining a number of internal attributes which only the specific **Component** instance can access. The internal memory of the **Component** is preserved during every execution loop in runtime; in this way **Components** can also be intuitively used for the realization of finite-state machines. The initialization of the **Components** internal parameters can be managed through eXtensive Markup Language (**XML**) configuration files, thus making easy for the developer to control and modify the parameters of multiple **Components** within an ASGARD Application.

Access to external memory data from a **Component** is possible by the use of specific interfaces based on *functors* [59]. The fundamental concept of functors in the ASGARD philosophy is that the definition of the memory operation (i.e. a function of the type `read()`, `write()`, `getpointer()`, specifying the data-types to be handled) is decoupled from its actual implementation. A more detailed description of such interfaces will be given in Section 3.5.3. Nevertheless, the effect on the **Component** implementation is that the same functor interface can be used with multiple data-transfer types. For example, a data buffer or alternatively a single memory object can be seamlessly interchanged, thus increasing the flexibil-

ity in the **Components** usage and definition of a system architecture. According to the ASGAR framework there are no limitations in the number and type of interfaces that can be specified in a **Component**. Some examples of practical usage are: input/output (I/O) ports managing data streams, pointer references to complex shared memory objects, interfaces to **OS** network resources, control and triggering of time events. In ASGAR, the developer has the freedom to create new attributes and interfaces at will. **Component** interfaces can also be utilized to connect to memory objects external to the flow-graph, thus, for example, creating options for the external control of the **Component** configuration parameters.

The following pseudo-code provides an example of the definition of a generic **Component** in ASGAR:

```
class MyComponent : public Component
{
MyComponent(string comp_name, Configuration config_struct){
    ...
    // Declaring the external (functor-based) data interfaces
    an_input_object< void(int&) > read_data_d;
    an_output_object< void(string&) > write_a_string;
    ...
}

void Do(){
    ...
    int my_int_var;
    // Using an external interface to acquire data
    read_data_d( my_int_var );
    // Do some processing
    string out_str = CreateAStringMethod( my_int_var );
    // Generate output data
    write_a_string( out_str );
    ...
}

string CreateAStringMethod(int input) {...};
} //end of MyComponent
```

3.5.2 Managing the system execution

In order to operate in runtime, the **Do()** method of a **Component** needs to be executed over a thread of execution. In order to manage multiple parallel threads within an ASGAR **Application** in a modular fashion, the **Module** software abstraction is introduced. The purpose of the **Module** is to handle the creation and execution of an independent thread within an ASGAR **Application** process.

The design concept behind the `Modules` is to de-couple the definition of the data processing operations (i.e. the `Components`) from their actual runtime behavior (i.e. as controlled by the `Modules`). A `Module` is a software class object which features a thread handler and a list of pointers to multiple `Component` instances. During a single loop of execution of the `Module` thread, the `Do()` methods of the `Components` in the list are called sequentially thus enabling their runtime operations.

The execution sequence of `Components` in a `Module` is determined by the order under which they are loaded onto the `Module` instance. Complex execution patterns, enabling a unique `Component` instance to run multiple times during a single loop iteration, can be achieved by properly managing the initialization of the `Module` list. A visual representation of how the `Components` execution flow can be mapped onto a `Module` is provided in Figure 3.6. Let us assume, for example, that during a single execution cycle (e.g. the time of a frame in a time division based system), data is retrieved from `Component A` and `B`, processed in `Component C` and eventually an output is generated in `Component A` (Figure 3.6.a). Since all the mentioned operations are part of a unique execution flow (i.e. data is processed by the `Components` always in the same order), their execution in ASGAR is achieved by loading the related `Component` instances over a single `Module` object (Figure 3.6.b).

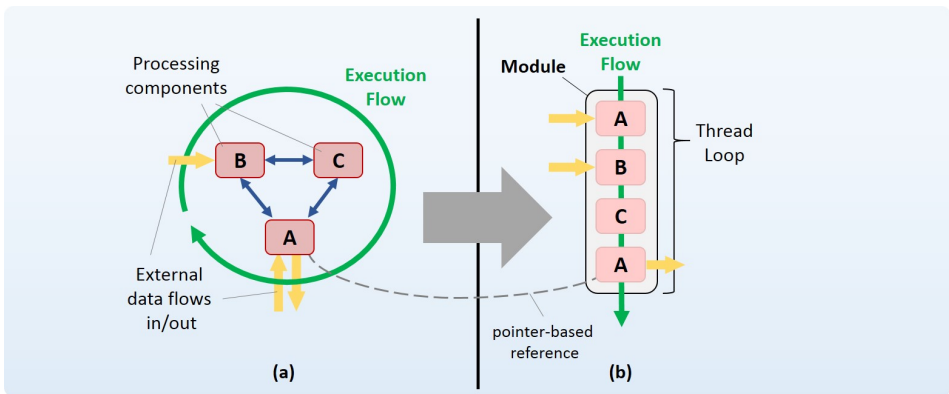

Fig. 3.6: Mapping of a system execution flow (a) into a `Module` object (b)

The `Module` abstraction allows to group coherent processing tasks into a single execution routine. Concurrent routines can be run on parallel threads by using multiple `Module` objects. The creation of a `Module` instance and the loading operation of `Components` are performed according to the following pseudo-code instructions:

```
// create components instances
CustomComponent A* = new CustomComponent("CompA", configuration))
```

```

CustomComponent B* = new CustomComponent("CompB", configuration))
//create Module instance
Module my_module;\\
// load components onto the Module:
my_module.AddComponent(A); // A is loaded first
my_module.AddComponent(B); // B is loaded as second
// Start the Module
mod.Start();
// After this point the Do() method of A is first called
// and subsequently the Do() method of B in a continuous loop
do_something(some_time);
// Stop the Module
mod.Stop(); // Components halt their execution

```

3.5.3 A multi-purpose communication interface

In ASGARDD the control of the system execution is in the hands of the developer who can decide how many threads to employ and how to load the **Components** into the **Modules**. This approach aims at easing the definition of data-flows and the implementation of customized system architectures. In this context however, proper measures have to be taken in order to safely manage concurrency aspects (e.g. multiple accesses to shared memory objects, threads synchronization) which are typical of multi-threaded applications. In ASGARDD, concurrency control mechanisms are embedded into the communication interfaces which link the **Components** one to another. These “smart” interfaces are named **Communication Objects (CO)**. **COs** are essentially software class objects which handle the allocation of shared memory objects within an ASGARDD **Application**. **COs** enable the transfer of data and information between multiple **Components** and between the **Components** and the ASGARDD System environment. A scheme of the **CO** is depicted in Figure 3.7.

COs are designed to support the management of customized data-types, classes, as well as multiple data-transfer solutions. The ASGARDD Core library currently support **COs** as buffers, shared class objects, pointer-based objects, time events and also sockets for Transmission Control Protocol (**TCP**) clients. A scheme of the internal architecture of a **CO** is provided in Figure 3.8. A **CO** class object embeds a memory data object which can be accessed by the usage of public methods specified by the **CO**. As a matter of example, in the scheme two **read()** and **write()** methods are considered. In order for a **Component** to call these methods, a connection with the functor interfaces [59] is established. In a context of object-oriented programming functors provide an interface for managing function calls similarly to function-pointers and callback-functions. The process of associating a functor to its target function or method is named *binding*.

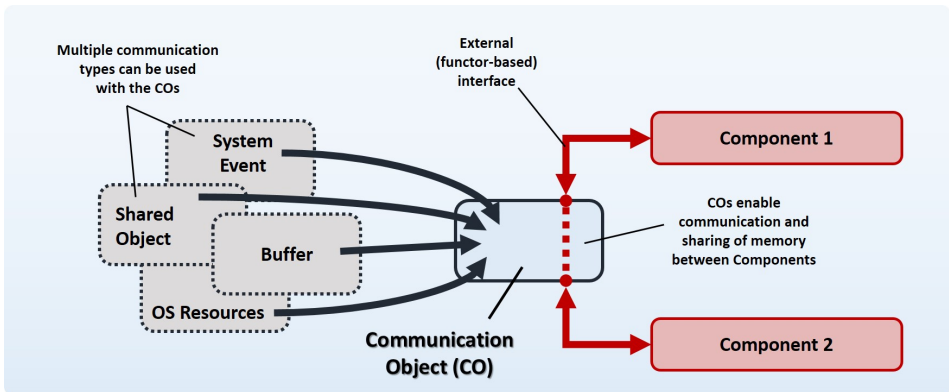

Fig. 3.7: Data communication by means of a Communication Object in ASGARD

The binding of the `Component` functors to the target `CO` methods typically occurs when the ASGARD System is created. However, runtime re-configuration of the `Components` connections are also supported by the framework. The usage of `COs` and functor-based interfaces improve the modularity of the system architecture. The implementation details of the `COs` methods determine the characteristics of the data-transfer occurring between two `Components`. A comprehensive overview of the available `COs` in ASGARD is provided in Table 3.1.

By simply substituting the `CO` type it is possible to radically change the behavior of the data-flow without intervening on the `Components` internal implementation. For example, a `read()` command can be executed right-away if it is associated to an `Element CO`, or instead becoming a blocking operation if bound to an `Event`

Table 3.1: List of `COs` available in ASGARD. All the `COs` are implemented as thread-safe memory objects thus supporting multiple read and write operations

CO Type	Characteristics
Element	<i>Enables simple write/read operations on a memory object</i>
Pointer Element	<i>Provides a pointer-based access to a memory object</i>
Event	<i>Provides blocking and non-blocking access to a memory object based on time events</i>
Buffer	<i>FIFO queue</i>
Pointer Buffer	<i>FIFO queue where the elements in the queue are pointers to memory objects</i>
Socket	<i>Interface to a TCP socket connection in client mode</i>

CO. Moreover, as shown in Figure 3.8, multiple functors can also be bound to the same CO method: such Components may also be part of independent Modules thus threadsafe access to the CO is required. The way COs are implemented support the execution of atomic operations [60] with the memory by exploiting an embedded mutex [61]. Whenever a CO method is called, access to the internal data is granted on a first-to-come basis by interrogating the mutex.

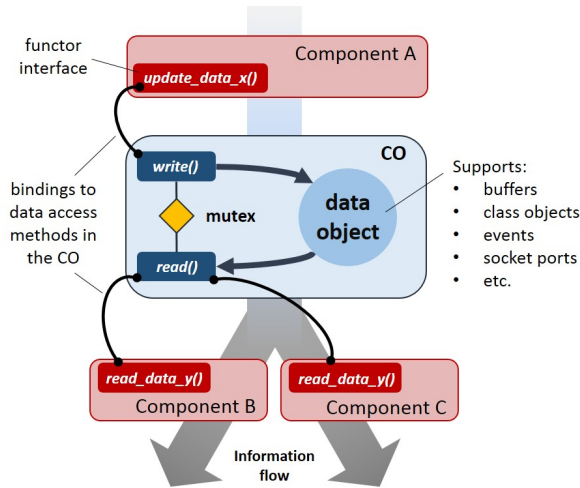

Fig. 3.8: Example of the connection of multiple Components through a Communication Object

COs are designed to support complex data class object thus increasing the abstraction level of the system implementation. For example, a register or database storing organized information about the network status, can be implemented as a class object with specialized methods for the manipulation of its internal data. If such register is created as a pointer-based CO, Components in the system can easily access its public methods thus expanding the inter-Component communications features, well beyond the simple write/read operations. Moreover, the management of pointer-based data objects supports a wide-range of design options which include the optimization of data-transfer of large memory objects (i.e. the exchange of pointer references generates considerably lower overhead in the memory management by the host OS) and the manipulation of protocol messages (i.e. class inheritance properties can be used to handle encapsulated messages with headers and payloads). Furthermore, the Socket CO provides an interface to directly access the network resources on the host computer, thus making the AS-GARD Application environment capable of establishing a TCP/IP connection with another ASGARD Application in the network. In Figure 3.9 an example of message exchange between multiple ASGARD Applications over a testbed network infrastructure is depicted. A server-type Application can be used to route messages between multiple testbed nodes as well as serving as a centralized unit

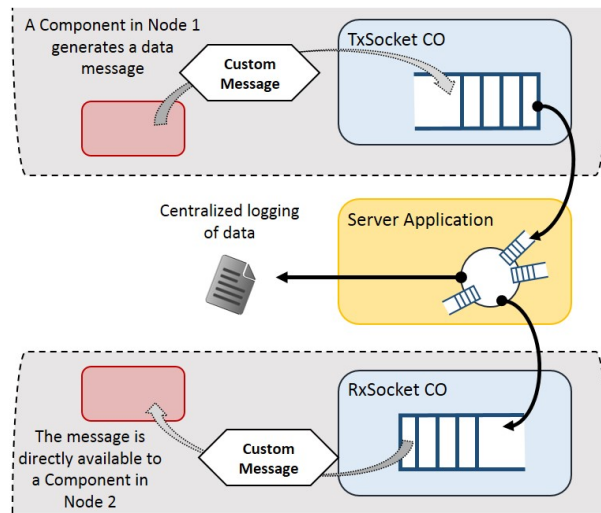

Fig. 3.9: Multiple ASGARD Applications running on the nodes of a testbed can directly communicate, exchanging high-level messages.

for the logging and display of data.

3.5.4 Building an ASGARD application

A communication system architecture developed with ASGARD consists of a graph with multiple instances of **Components**, **Communication Objects** and **Modules**, which are linked one to another. Managing the initialization, runtime execution and reconfiguration of such complex system may be a cumbersome task. In order to ease this process, the ASGARD framework allows to encapsulate a coherent system design within an **AsgardSystem** software abstraction. An **AsgardSystem** is a class object which contains the instantiation and configuration of all the ASGARD elements present in the architecture. Within an **AsgardSystem** all the connections between **Components** and their loading on the **Modules** are specified. An **AsgardSystem** is also a fully customizable object. One of its most important features is the possibility of defining public methods controlling the runtime behavior of the system. Examples in this sense are **Start()/Stop()** routines for managing the activation or de-activation of **Modules**, and other methods for the re-configuration of **Components** parameters and graph connections. Descriptions of **AsgardSystem** architectures developed for the experimental trials, will be given later in the thesis, in Chapters 5 and 6.

Recalling the scheme of Figure 3.4, an **Application** represents the uppermost

level of abstraction in the ASGAR framework. An `Application` defines the executable process that gets compiled on the host and can be run by the user. The modularity provided by the usage of the `AsgardSystem` enables an ASGAR `Application` to easily manage multiple system architectures during runtime. As a consequence, customized execution scripts which, for example, can modify the role of a testbed node during a trial (e.g. an `AP`, a user terminal, a relay), can be implemented as an ASGAR `Application`. ASGAR `Applications` support the execution of experiments by enabling the utilization of Network Time Protocol (`NTP`)-based synchronization services, which are typically available in the host computers. Assuming multiple hosts to be synchronized, it is simple to program an ASGAR `Applications` in order to run coordinated operations on multiple testbed nodes. In this way complex experiment sessions can be scripted and executed in a fully automated fashion.

3.5.5 Integration with other SDR platforms

One of the most important aspects of experimental research is the reproducibility of trials. By exploiting common hardware solutions `SDR` platforms provide in principle a formidable tool for directly replicating the radio system design –and thus the experiments– on multiple testbeds with comparable capabilities. At the present day however, a variety of `SDR` platforms are commonly used across the research community. The widespread incompatibilities between these tools, very often prevent the collaboration between the developers and thus the progress of the experimental investigation. Means for the integration of software components between heterogeneous `SDR` platforms may then contribute to overcome such limitations.

The design of ASGAR `Components` presents common characteristics with other `SDR` frameworks. The implementation of the executable `Do()` method in particular, is very similar to the methods used in the basic blocks of GNU Radio and in Iris (i.e. the `work()` and `doProcess()` methods respectively). This feature enables in principle the execution of components developed with such platforms over the ASGAR `Modules`. Starting from this consideration, software interfaces allowing the complete integration of `External Components (EC)` into ASGAR system applications can be designed. Thanks to the collaboration with Trinity College Dublin and CSP Turin, `Wrapper Components` for both Iris and GNU Radio blocks have been developed and are expected to be included in the future releases of the ASGAR code. The most challenging aspect of the `ECs` integration in ASGAR is the management of the input/output data-transfer incongruences. This is the main task of the `Wrapper`, to handle the data-types casting and the interfacing with the `COs`. The basic functioning of the ASGAR `Wrappers` is depicted in Figure 3.10. During the initialization phase, the `Wrapper` accesses the external library of components and loads the `EC` instance into the ASGAR `Application`. The

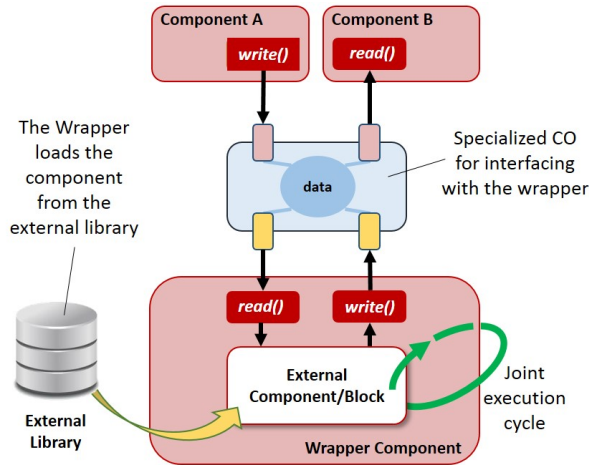

Fig. 3.10: Architectural principle of the ASgard Wrapper for external processing components.

Wrapper then sets the connections between the **EC** instance and a platform-specific **CO** to be used for the data transfer. The runtime execution of the **EC** is performed by using the **Wrapper** similarly to the native ASgard **Components**. The creation of **Wrappers** is a recent development to the ASgard framework, currently covering a limited set of **ECs**. Extensive testing is ongoing, aiming for example at the optimization of the runtime performance in challenging data-transfer conditions. We believe that software interfaces like the **Wrappers** can be a valuable resource for the enlarged community of developers, allowing rapid integration of system features and the sharing of common experiences in the development of **SDR** experimental applications.

3.6 Discussion

In Table 3.2 is reported a brief summary of main design characteristics of ASgard, in comparison to the other **SDR** software frameworks discussed in this chapter, i.e. GNU Radio and Iris. While all solutions share fundamental characteristics, such as the component-based design of the system, the main differences rely in the management of multiple data-flows. In particular, GNU Radio greatly focuses on the computation efficiency, adopting a centralized scheduler, while Iris and ASgard enable greater flexibility with the usage of **Engines** and **Modules**. The essential element of novelty introduced by ASgard is the embedding of all flow-control mechanisms into the communication interfaces connecting the processing components in the flow-graph. As a consequence, ASgard enables a fully de-centralized management of data-flows thus easing the creation of experi-

Table 3.2: Comparison of the architecture characteristics of SDR software frameworks

	GNU Radio	Iris	ASGARD
Processing block design	<ul style="list-style-type: none"> -Independent blocks with input and output ports. -I/O data ratios need to be specified. -C++ implementation. 	<ul style="list-style-type: none"> -Independent components with input and output ports. -I/O data ratios can change dynamically. -Component execution is managed by the internal Iris scheduler. -C++ implementation. 	<ul style="list-style-type: none"> -Independent components with input and output ports. -Functor-based I/O connections -Do() method defines a single processing task. -C++ implementation.
Flow graph description	<ul style="list-style-type: none"> -Based on Python scripts. -GNU Radio Companion GUI. -At least one source and one sink blocks must be present. -Graph loops not allowed. 	<ul style="list-style-type: none"> -XML-based description of the flowgraph. -XML Parser and reconfiguration manager manage the flowgraph connections. -Controllers may reconfigure the graph connections. -Graph loops are not allowed. 	<ul style="list-style-type: none"> -Described in the AsgardSystem as source code. -Modules handle the threading abstraction. -Configuration parameters managed by XML files. -Components are interconnected by COs.
Dataflow control	<ul style="list-style-type: none"> -Centralized. Handled by internal scheduler. -Sequential execution of blocks in the flowgraph. -Platform initially conceived for mono-directional flowgraphs. -Efficient computation, low flexibility. 	<ul style="list-style-type: none"> -Engines provide a modular abstraction for parallel threads. -<i>Phy Engines</i>: directional dataflow, sequential execution of components. -<i>Stack Engine</i>: bidirectional dataflow, parallel execution of components. -<i>Events</i> support asynchronous control and data delivery to controllers. 	<ul style="list-style-type: none"> -Distributed control. Determined by the combined usage of Components, Modules and COs. -Multi-threaded system handled by the OS scheduler. -COs embed concurrency control mechanisms -Very-high design flexibility at the cost of increased complexity.
Data-transfer	<ul style="list-style-type: none"> -Mainly buffer-based. -Data access managed by the framework. -Multiple dataset can be queued to a given block (multiple independent threads can run concurrently). -GNU Radio messages enable asynchronous data delivery out of the flow. 	<ul style="list-style-type: none"> -Defined according to the Engine. -Phy engines use buffered data sets. -Stack engines support pointer-based data transfer. 	<ul style="list-style-type: none"> -Various data-transfer methods implemented through different CO's but can be used across different Components. -Thread safe data access. -Pointer based data transfer for high efficiency.

mental applications with novel types of communication system architectures. The drawbacks of such design strategy rely in a potentially increased architecture complexity, and a lower computation efficiency, if proper design solutions are not enforced by the developer. The goal pursued with ASGARD is the creation of a development platform specifically designed to support the needs of academic research. In this sense, solutions easing the control of experiments and multi-node testbeds have been directly integrated in the platform core framework. Moreover,

interfaces and wrappers enabling the integration with other [SDR](#) platform solutions have been considered as a key element in order to facilitate the cooperation between research projects. In the next chapters the design aspects related to the realization of wireless network testbeds with ASGARD will be discussed in detail. Practical examples of communication system architectures implemented, and specific solutions adopted for the execution of experiments will be presented.

Experimental methodology and practical execution aspects

4.1 Introduction

When considering the setup and execution of experiments, one of the main challenges relates to how to ensure the trustworthiness and statistical significance of the obtained results. In this context, the details about the employed methodology and the practical execution of the trials are of fundamental importance. This chapter addresses the challenges related to the experimental validation of distributed network concepts, aiming at developing specific methodologies and approaches for the execution of trials. A clear understanding of the research objectives is the first step towards the definition of experiment scenarios and execution approaches. Critical areas for the execution of experiments relate to the planning of trials, configuration of the hardware, deployment of the nodes and monitoring of the environment. All these aspects will be considered in the discussion of this chapter. The contents of this chapter have been in large part included in the authored and co-authored publications [8] and [11]. Details of the experimental methodologies and practical execution approaches are also included in [13], [12] and [15].

4.2 Terminology and requisites of experimental trials

At first, the essential terminology utilized in the chapter to describe the objectives, elements and execution phases of the experimentation —is provided. According to the definition given in [62], the process of measurement and evaluation of wireless communication protocols and devices is defined as *wireless benchmarking*. The object of a benchmarking process during the experiments is then defined as system under test (**SUT**). An overview of the essential elements in the execution of experiments is given in [11]. A brief summary is provided here:

- *Measurements* - Data collected by sensing agents within a specified measurement period. Examples are: signal power measurements, covariance matrices, (complex) channel coefficients and raw samples.
- *Performance Metrics/KPIs! (KPIs!)* - Numerical estimations enabling the *evaluation* of the **SUT**. Examples are: **SINR**, throughput, time misalignment, number of iterations for an algorithm to converge, number of beacon detections, statistics about channel occupancy, etc.
- *Score* - Collection of multiple metrics for the comparison of **SUTs**. For example, the score of an **RRM** algorithm may be given by both the peak throughput in the cells and the throughput achieved by the worst 5% of the users.
- *Criteria* - The description of the principles determining the score computation, e.g. weighting of metrics. Criteria typically depend on the focus and the characteristics of the experimentation.

The experimental analysis of a **SUT** is typically organized as an ensemble of procedures and operations. In this project the following structure is adopted to describe the execution of experiments:

- *Experiment Run* - A single benchmarking operation with the testbed of fixed duration in time. It is typically repeated for multiple system configurations or testbed deployments
- *Experiment/Testbed drop* - A unique spatial deployment of the testbed nodes. Multiple experiment runs can be associated to a single testbed drop.
- *Experiment Trial* - A set of experiment runs (even considering multiple drops) focusing on the evaluation of a specific communication feature or impact of a configuration parameter.

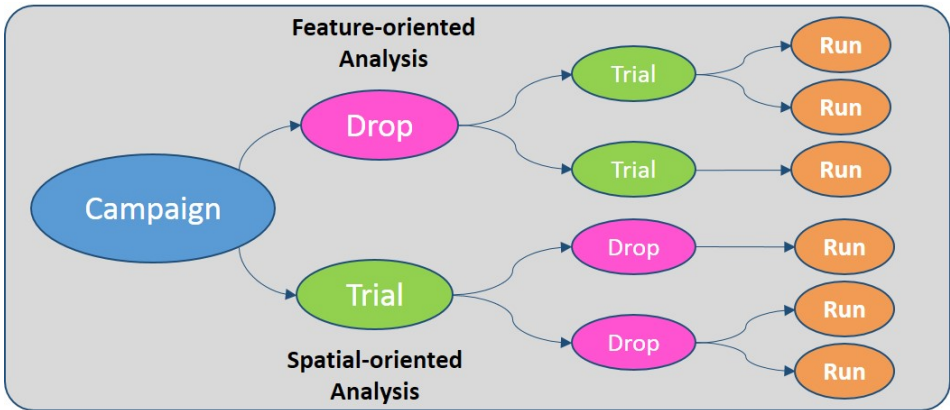

Fig. 4.1: Organization of an experimental/measurement campaign. Various combinations of trials and drops can be used, depending on the specific focus of the campaign.

- *Experiment Campaign* - The combination of all runs/drops/trials associated to the experimental evaluation of a concept, in a single deployment environment (e.g. the link path loss analysis in an indoor office scenario).

In general, various combinations of trials and drops can be adopted in the campaign, depending on its focus. Typically if the main interest is in a feature-oriented type of analysis (e.g. the impact of a specific configuration parameter), multiple trials can be run for a single spatial drop. Conversely, if a spatial-oriented analysis is the target, the opposite can be adopted. A graphical summary of the campaign organization is given in Figure 4.1.

The ultimate objective of the experimental methodology is to ensure the validity and reliability of trials results. In this sense, the following requirements should be satisfied:

- *Comparability* - Two independent benchmarks (i.e. the outcome of two independent trials) should be taken under consistent conditions to be comparable.
- *Repeatability* - Conditions must be defined, under which the results of two independent benchmarks can be considered equal. This aspect is particularly relevant for experiments in dynamic propagation environments where, for example, the channel response is never constant and hard to predict.
- *Reproducibility* - Solutions must be found, enabling others to replicate the outcome of the trials, with testbeds of comparable capabilities. This aspect is a fundamental step ensuring the cross validation of concepts among independent research institutions.

In order to fulfill such requirements, automatic procedures for the execution of the runs/trials should be adopted, helping in enforcing a predictable and time-regular sequence of operations. Furthermore, the monitoring of the experimental conditions is also important —monitoring operations should be performed consistently throughout the execution of runs (i.e. before, during and after) in order to detect potential anomalies in the environment which may compromise the comparability and the repeatability of the benchmarks.

4.3 Experimental objectives

This thesis aims at the experimental validation of distributed network concepts, with a specific focus on **FD-ICIC** algorithms for the resource management in small cells local area networks. In indoor environments —assuming a **CSG** user affiliation policy to be adopted (i.e. the user can connect only to authorized **APs**)— the uncoordinated deployment of the nodes may lead to sub-optimal network topologies where users suffer of poor signal quality due to excessive inter-cell interference. In this context, distributed **FD-ICIC** schemes can provide capacity improvements by allowing every **AP** to orthogonalize their allocated spectrum resources in respect to neighboring interferers.

The performance of distributed **FD-ICIC** schemes, as well as other distributed network solutions, is a complex problem to analyze because of the many elements contributing to the final outcome. A simplified representation of the problem is proposed in the scheme of Figure 4.2. The overall network performance is the result of multiple interactions between independent decision-making processes —running at the nodes— and the surrounding environment. In the case of distributed **FD-ICIC** schemes, for example, a decision about the spectrum allocation in a cell typically relies on interference estimations which are obtained starting from channel measurements in the deployment environment. Whenever an **AP** selects a set of resources for transmission, the starting interference conditions in the network are modified, thus the decision-making process of other **APs** is also affected. In the meanwhile, since channel conditions and network topology may have changed, the performed decisions may have become sub-optimal in respect to the overall network performance.

In this project, the objectives of the experimentation are essentially two:

- **Proof-of-concept and general feasibility**, the verification of the concept's contribution to the performance improvement in real-world network deployments.
- **Validation of simulation-based studies**. The verification of numerical

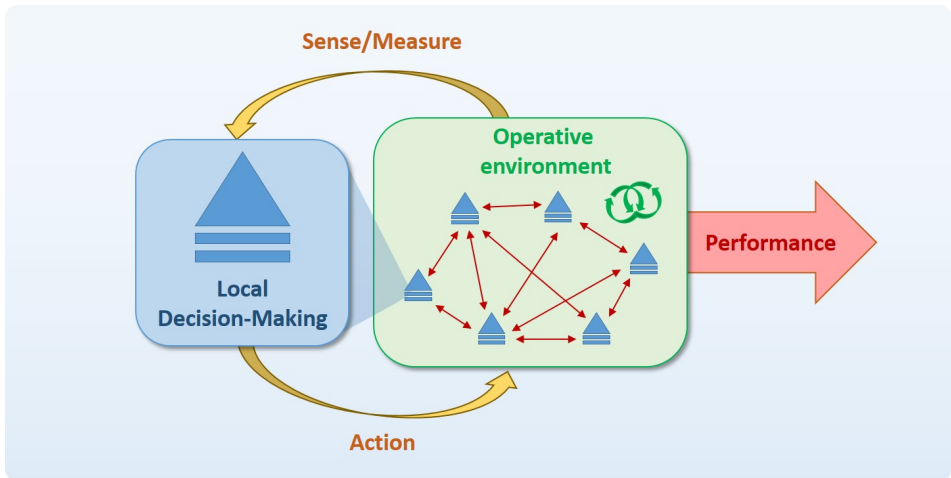

Fig. 4.2: Network performance in presence of distributed network schemes. The typical “Sense/Act” loop executed at every node is highlighted. The operative environment typically comprises of the network topology, propagation environment, channel resources configuration.

performance results obtained in system-level simulations — where reference deployment scenarios and stochastic propagation models are typically employed.

In order to ensure a comprehensive validation of concepts, two major aspects should be targeted by the experiments:

- The runtime interactions between multiple independent decision-making processes acting in a common environment.
- The impact of the deployment scenario characteristics, i.e. building geometry, channel propagation, on the network topology.

Due to the substantial differences between the two, in terms of objectives and testbed requirements, in this thesis it has been decided that their experimental evaluation can be better achieved if a separate analysis is pursued. In particular, a *live execution* approach has been developed for the investigation of runtime system execution aspects, while *hybrid-simulations* have been developed for deployment scenario-oriented type of analysis. The live execution is briefly introduced in Section 4.4 and dealt with later, hybrid-simulations are described in Section 4.5 and dealt with in this chapter.

Although the developed methodologies and approaches have been initially con-

ceived for the verification of **FD-ICIC** schemes, their application have proven effective also for the analysis of other interference mitigation solutions (e.g. advanced receivers for **IRC**) or distributed schemes (e.g. runtime synchronization algorithms).

4.4 Live Execution

The outcome of a distributed decision-making process, e.g. the frequency reuse in a network, is typically not instantaneous but rather the result of multiple iterations where repeated measurements are performed, and data exchange between the nodes may occur. Considering that in a dynamic environment the channel and/or topology conditions continuously evolve, the effectiveness of the decision-making is constantly challenged over time. Further, since decisions are based on the input received from channel measurements and —potentially— information exchange among the nodes, **PHY** non-idealities, delays and communication errors, also affect the overall system performance.

All previous aspects can be related to the runtime execution of the systems. For this reason, the preferred strategy for their experimental analysis involves the creation of hardware prototypes and their utilization in “*live execution*” experiments. During the live execution it is assumed that all relevant communication protocols are executed in real time —at every moment, the **SUT** performance reflects the instantaneous operating conditions. Live execution experiments are well suited for the investigation of time-varying phenomena, in particular variations in the channel conditions and network topology due, for example, to human presence or mobility of the terminals, can be evaluated comprehensively. Furthermore, since communication protocols are executed in real-time, the **SUT** capability of reacting to failures, errors and delays can also be captured. In this context a more accurate evaluation of the network performance is possible, as well as the analysis of the decision-making processes resilience.

The utilization of the live execution approach in experiments requires first of all to develop a testbed supporting the execution of all necessary protocol stack layers. The design of such type of testbeds is typically very challenging because any kind of non-ideality or limitation in the system features directly affects the scope and accuracy of the analysis. For distributed network systems, the greatest challenge is typically represented in the number of nodes which can be accommodated in the testbed.

In this thesis, live execution experiments have been employed for the proof-of-concept of **FD-ICIC** algorithms as well as for a distributed algorithm for the runtime synchronization of indoor small cells. In both cases, the realized testbed

enabled the full execution of the features of interest although some simplifications have been made, especially in respect to the PHY layer design. The objective of the live execution trials aimed at verifying the general feasibility of the concept and at validating baseline performance results previously obtained in simulation-based studies. The details about the realized testbed configurations —as well as the design of trials— are very much related to the specific concepts analyzed. For this reason, in order to better described adopted solutions, a more detailed discussion about live execution experiments in this thesis, will be given in Chapter 6, after the related concepts have been introduced.

Despite their advantages in providing accurate and detailed information about the system performance in complex execution environments, live experiment trials are hard to manage and their utilization should be carefully considered depending on the specific research objectives. One of the main limitations is that during an experiment run only a single system configuration can be evaluated per time. If, for example, the impact of one or more configuration parameters has to be investigated, multiple independent runs should be executed for every different value considered. Furthermore, depending on the characteristics of the time-varying phenomena targeted by the experiments, the duration of a single run may vary from few tens of seconds up to several hours. In this context, the completion of experimental campaigns where multiple combination of configuration parameters (or multiple operating scenarios, network topologies) are considered, may become completely unfeasible.

4.5 Hybrid Simulation approach and Channel Sounder

The evaluation of distributed wireless networks requires a large number of nodes and link realizations to be analyzed in order to obtain a statistical coverage of the possible operating conditions experienced by users in the network. In the case of FD-ICIC schemes, for example, the interference mitigation capabilities of the algorithms vary according to the number and density of interferers, thus depending on the specific network topology considered.

In simulation, multiple topologies and operating conditions can be analyzed by considering random network deployments (i.e. *layouts*) in reference scenarios. Stochastic channel models are also often employed, providing a statistical description of the wireless links characteristics. The overall network performance is typically assessed on a per-user basis where results across multiple layouts are aggregated thus generating distribution statistics. Unfortunately, applying this validation approach in live experiments is usually unfeasible due to the difficulties in replicating multiple, large, network configurations. Hence, aiming at developing

an alternative solution to such problem, in this thesis an approach named “*hybrid simulation*” has been developed.

4.5.1 Scenario modeling in simulation-based studies

One of the main motivations for the adoption of the hybrid simulation approach is the need to compare the results obtained from experiments with the insights coming from simulation-based studies. System-level simulations are a fundamental part in the concept validation due to their advantages in the large-scale analysis of configuration parameters and operative conditions. However, given the differences which may exist—in terms of system execution and environment assumptions—between simulations and experiments, the comparison of performance results is often difficult to achieve. Developing methodologies enabling a better integration between the two validation approaches enables to effectively combine the different insights obtained, thus contributing to a more comprehensive proof-of-concept.

In system-level simulators, a number of abstractions are typically employed to model the execution of communication system protocols. A scheme of common modeling assumptions adopted in simulation is depicted in Figure 4.3—the implementation of an RRM mechanism in a network AP is taken as matter of example. Resource allocation mechanisms may be executed on a time-frame basis, relying on traffic models for describing the user data request. FD-ICIC schemes—which operate at RRM level—may exploit DSA mechanisms thus implementing decision-making processes which manage the spectrum allocation on the basis of spectrum sensing information and channel capacity measurements. These inputs can be provided in simulation by a PHY model which computes SINR estimates on the basis of the resource occupation in the network, and wireless link parameters (identified by solution *a*) in the Figure), e.g. path loss, shadowing. Delivered throughput over the links can be obtained by mapping the SINR over the achievable capacity according to technology-specific formulations such as the modified Shannon formula, proposed in [63].

In the analysis of distributed network schemes—where the nodes topology has a fundamental impact on the system performance—the assumptions made in relation to the scenario modeling are of critical importance. The essential elements contributing to the scenario modeling are:

- The geometry of the environment
- The network deployment assumptions (e.g. density of APs, number of User Equipment (UE)s per AP)
- The channel propagation models.

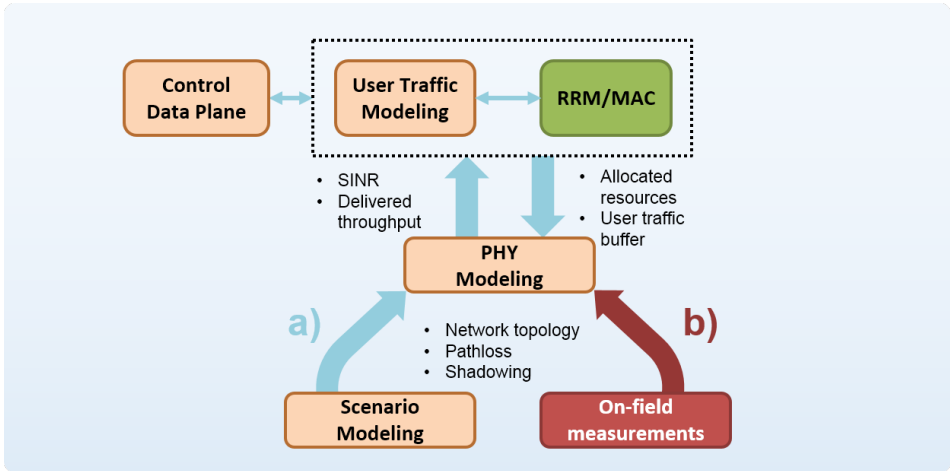

Fig. 4.3: Common modeling assumptions of a network AP in system level simulation. According to the Hybrid Simulation validation strategy the scenario model (a) is substituted by direct on-field link measurements (b)

In simulations, geometrically regular scenarios are often employed since they enable the utilization of parametric channel models, based, for example, on the number of path crossing due to walls and multiple floors. In order to ease the comparison of results, standardized reference scenarios are typically utilized in simulations. Examples of scenarios widely employed in literature for the analysis of local area small cell configurations are the *3GPP Dual Stripe* and the *5x5* scenario models—defined by the Third Generation Partnership Project (3GPP) consortium [64]—and the *A1-Indoor Office* scenario specified for the use with the WINNER II channel models [65]. Other configurations, typically derived or simplified versions of the previous, can also be found in literature, e.g. in [66] and [67]. A picture of the aforementioned reference scenarios is provided in Figure 4.4. The models all build upon a basic apartment unit of 10x10 m (i.e. with an area of 100 sqm) which is replicated over various geometrical configurations with corridors or empty spaces dividing multiple apartment blocks. Assuming maximum one AP to be deployed in every apartment, the models of Figure 4.4 allow to evaluate from 25 up to 40 different cells over the single-floor. If multi-floor, multiple-building configurations are considered, the number of active cells in a simulated network deployment can sum up to several hundreds.

The average size of a cluster of (formally) mutually interference-coupled cells—also often referred as *clique* size—varies according to the scenario dimensions and network density. In office/residential scenarios, as those of Figure 4.4, it is the deployment ratio probability (DRP) of APs in the apartments/rooms—together with the channel modeling assumptions—which determines the clique size. In [68]

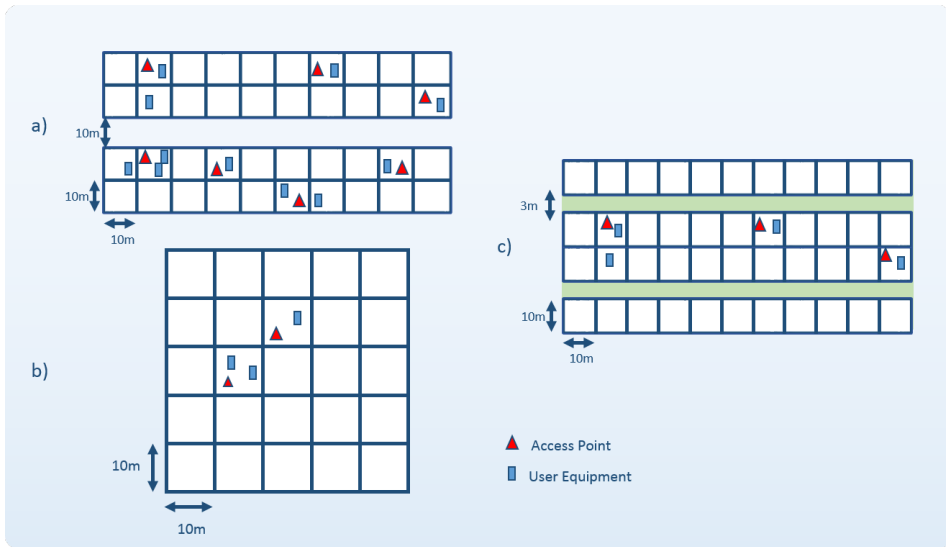

Fig. 4.4: Single-floor layout of the Dual Stripe (a), 5x5 (b) and A1-Indoor Office (c) simulation scenarios as specified in [64] and [65].

a study with the 3GPP Dual Stripe scenario and propagation models of [64] has been conducted aiming at investigating clique sizes for interference-limited indoor network deployments. Findings from this study indicate that even in high-density conditions (e.g. 120 APs for 120 rooms in a 6-floor building configuration) the clique-size rarely exceeds the number of 4 (i.e. an SINR threshold lower than 12 dB is assumed for having a clique).

4.5.2 Exploiting on-field path loss measurements for the validation of simulation scenario assumptions

In order to bridge the gap between simulations and experiments it can be helpful trying to split the general validation problem into smaller, more focused, items. In particular, assuming that runtime execution aspects can be addressed by using live experiments, a different approach can be adopted for the validation of the deployment scenario assumptions and thus the system performance, in relation to large network deployments. This is indeed the scope of the hybrid-simulation concept in this thesis. The basic idea is to exploit accurate information about practical network layouts in real-world environments in order to improve the accuracy of system-level simulations. In this context, moreover, it becomes also easier to compare results from pure simulation studies, since all other system modeling assumptions are consistent. Referring again to the scheme of Figure 4.3, when

running hybrid-simulation we substitute the input provided by scenario and propagation models (*a*), with measurements acquired on the field with a testbed (*b*).

Describing a real-world wireless network deployment with measurements, basically means to acquire a complete information about all existing links combinations in such deployment. In this sense, the measurement of the link path loss of major interest since it provides an aggregated information about the effects of the propagation environment —distance, shadowing, multipath fading, antenna radiation patterns— on the links. A full path loss map about all link combinations about a number of spatial positions in the environment, allows to then exploit the power of system-level simulators for the large-scale analysis of multiple network deployments across such positions.

Since a large number of nodes locations are typically needed for comprehensively characterize the system performance in a given deployment environment, the main consists in how to obtain such large data-set. The path loss between two nodes link can be estimated by transmitting a signal of known power from one terminal, and by measuring the received power at the other. In order to analyze all link combinations existing between a certain number of locations, a node of the testbed should be, in principle, deployed at each of these locations. However, since the number of nodes typically available in a testbed is lower than the targeted number of positions, an alternative solution must be found. In static propagation conditions, multiple re-deployments of the testbed can be utilized to increase the number of positions analyzed, by assuming that —with reasonable approximation, adopting proper precautions— the link path loss will not change in between the re-deployments. This kind of measurement approach referred in this thesis as *channel sounder* execution mode.

A graphical representation of the main phases involved in the channel sounder execution concept are provided in Figure 4.5. The first step (*a*) relates to the individuation of a number of spatial locations in the environment, constituting the data-set to be later used in hybrid-simulations. After a set of positions have been individuated, multiple sub-sets should be defined —of size equal to the number of the available testbed nodes. During a single trial a sub-set of positions is covered by the testbed (*b*). A reference signal is transmitted by every node (*c*) and measurements are performed (*d*). Coordinating the transmission/measurement operations can be achieved in multiple ways, e.g. adopting a TDD transmission scheme. When all link combinations have been measured, testbed nodes are re-located onto another sub-set of positions (*e*). The procedure is repeated until all link combinations have been covered. The output of the trials is typically a matrix of dimensions $N_{nodes} \times N_{nodes}$ with a number of independent links equal to:

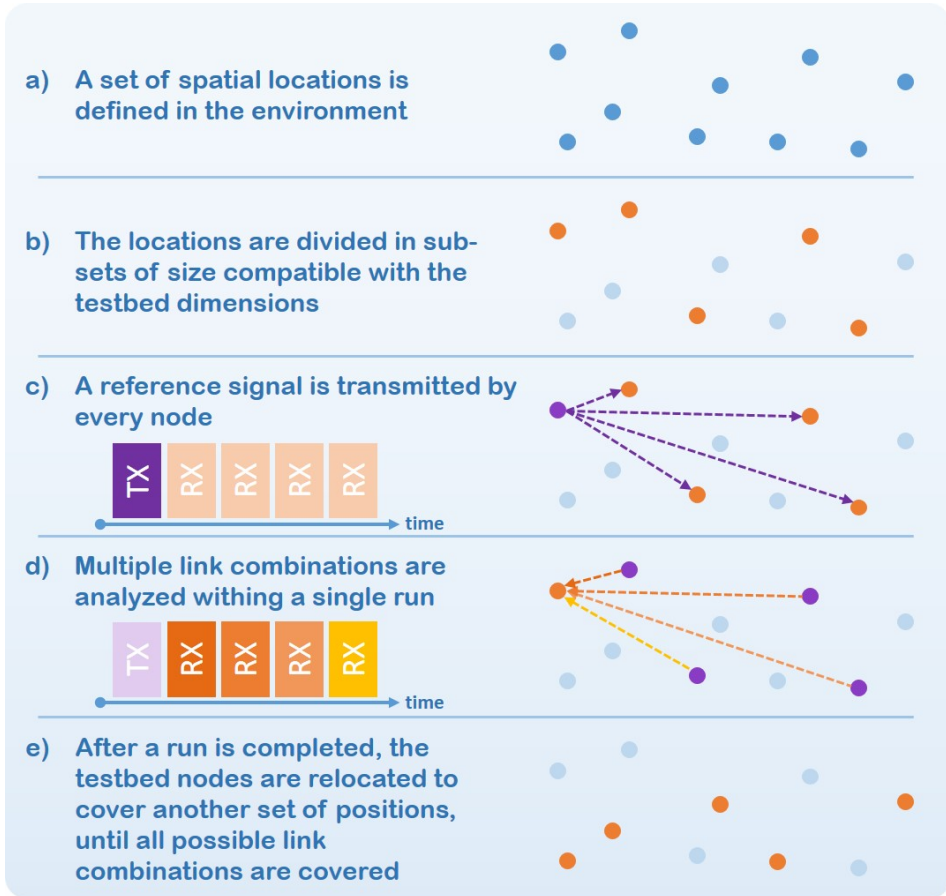

Fig. 4.5: Main phases of the Channel Sounder execution approach. Multiple testbed drops are employed to cover a number of positions larger than the number of available nodes. A TDD-based transmission allows to measure all the links in a drop within a short time interval.

$$N_{links} = \frac{N_{nodes}^2}{2} - N_{nodes} \quad (4.1)$$

To be noted that, depending on how the testbed re-deployments are managed, the amount of measurements for every link combination may not be equal. Some link combinations may indeed analyzed more times than others. Given a sufficient amount measurements to be performed in time and/or frequency during a single trial, however, the reliability of path loss estimations can be ensured for all links.

4.5.3 Preparation and execution of trials

Given the typically large amount of trials and testbed re-deployments involved in a measurement campaign, prior planning and a precise execution methodology are essential requirements to enable an agile management of the experiments and ensuring reliable outcomes. Based on the experience gathered on the field, a procedure based on sequential steps has been defined for the execution of channel sounder trials:

1. *Planning of trials.* A measurement campaign with the channel sounder may require several re-deployments of the testbed hardware to be completed across multiple trials. Given the fact that the physical movement of testbed nodes is extremely time consuming (i.e. a configuration with about 10 nodes may require several minutes to be re-deployed) it is important to devise strategies to minimize the movement of nodes and repetition of trials. The amount of links to be measured during a campaign can be represented in matrix form, as in the example provided in Figure 4.6. In this case, it is assumed that a testbed with 16 devices is used for measuring 48 different spatial positions. The combinations of positions give a total of 1128 independent links to be measured. During a single trial, 16 testbed nodes give a maximum of 112 links which can be analyzed. For example, in the first trial (represented in Figure 4.6 by the box with the number 1) the positions from 1 to 16 are covered. Not in every trial it is possible to cover 16 new positions, therefore a lower number of links can only be analyzed. This is the case, for example, from trial 2 to 8 and from 10 to 14 (24 links analyzed). An optimal number of trials can be found if the total positions to be measured are a multiple of the testbed size (e.g. assume 49 positions were considered instead of 48: multiple trials would be needed just to cover the new link combinations introduced by the 49-th column/row). After the trials have been defined, it is also possible to minimize the amount of physical relocations of the hardware, by following an execution order as the one depicted by the red arrow (i.e. from trial 1 to 15), since max. In this case, only half of the testbed is relocated in most of the transitions from trial to trial.
2. *Pre-configuration of the nodes.* Prior to the execution of the trial, it is likely that the testbed hardware will require proper settings for the identification of nodes and transmission parameters. A useful tip relates to the careful planning of the nodes ID, such that it can be clearly determined which will be their physical position across different trials. The mapping of testbed hardware over the chosen spatial location is often source of potential errors during the practical execution of the measurements.
3. *Marking of the positions.* In order to enable the precise positioning of the testbed nodes and their re-deployment across multiple trials, the selected spatial locations in the environment should be clearly marked. Moreover, it

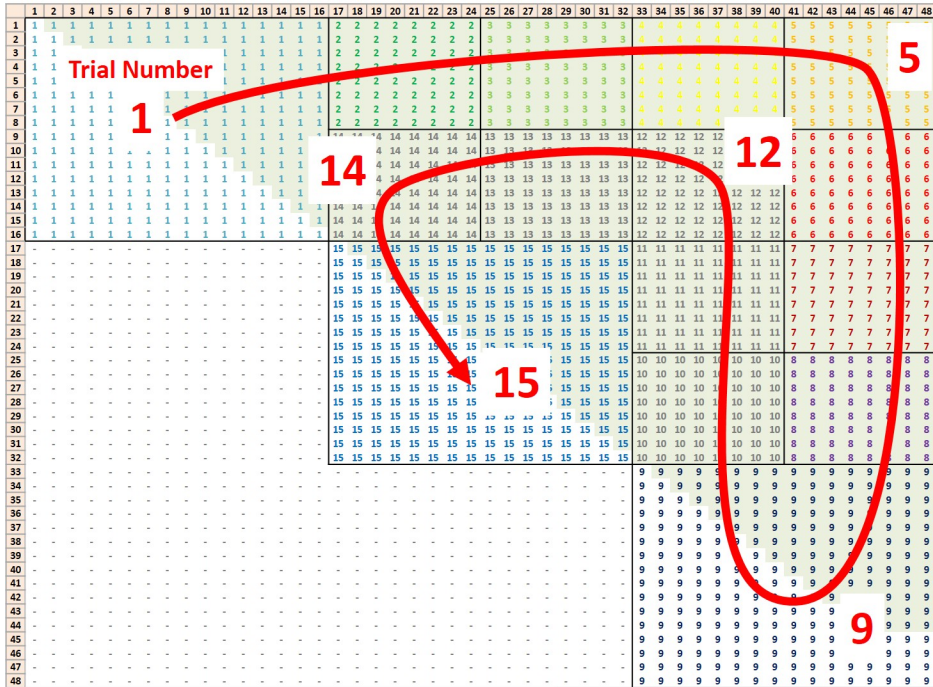

Fig. 4.6: Example of the link matrix utilized in the planning of the measurements. 48 different locations are considered, giving a total of 1128 independent link combinations. Labels on column and rows of the matrix indicate the spatial positions occupied by the testbed nodes during the trials. The numbered boxes represent independent measurement trials where only a sub-set of the links is analyzed. The red arrow indicates the optimal execution order of trials in order to reduce the amount of physical relocations of the hardware.

is recommendable to verify in advance the fitting of the testbed hardware into the locations (i.e. physical placement of the nodes, presence of power and network supplies) since the movement of the nodes should be made as easy as possible.

4. *Measurement of link distances.* In order to post-process the data and elaborate path loss statistics and models, all link distances should be accurately measured.
5. *Execution of the measurement.* The testbed equipment is placed on the field according to the trial plan. The pre-programmed channel sounder application is launched simultaneously on every testbed node. Measurement are collected and the log files are created. Independent measurements are generate for every carrier frequency considered.
6. *On-site data verification.* The measurement log-files are analyzed on the

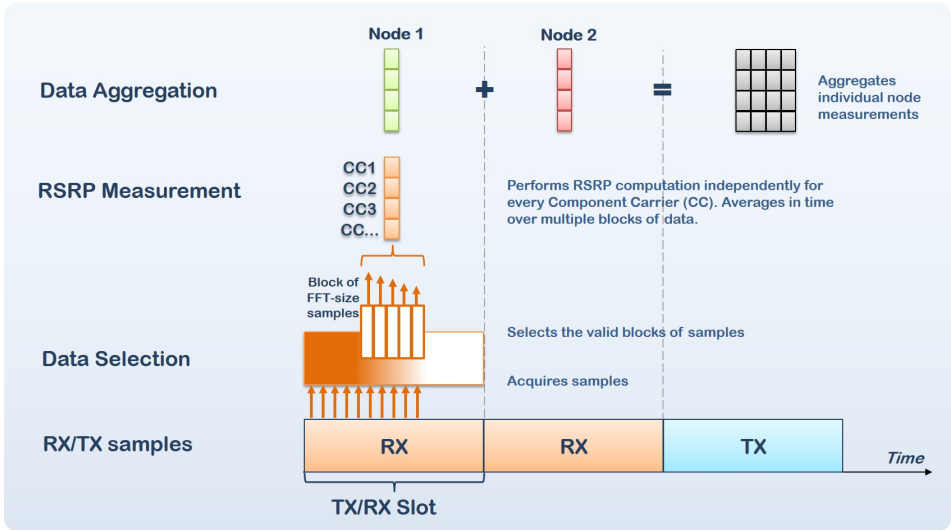

Fig. 4.7: The time-based measurement procedure with the channel sounder approach

field, aiming at detecting anomalies and errors. If necessary, measurements are repeated.

4.5.4 Configuration of the testbed

The channel sounder testbed aims at enabling the measurement of the link path loss in multi-node context. A TDD-based transmission scheme is at the basis of the testbed design, enabling the coordinated transmission/measurement procedures by the nodes. The main operations performed by the nodes during runtime are depicted in Figure 4.7. A basic time frame structure is defined, where the number of time slots equal to the number of nodes available for the measurements. Every node is assigned a single transmission (TX) slot, in an orthogonal fashion, during which the reference signal is transmitted. The remaining slots are instead configured for receive (RX) mode. Each node performs an FFT on the received samples and computes RSRP estimates over multiple spectrum chunks (i.e. defined as Component Carrier (CC) in the Figure) across the operating bandwidth. Eventually, measurements are averaged over time for the same node, and multiple nodes are aggregated over multiple slots in a frame, as such that information about all measured link combinations can be stored in a single data-structure.

The received signal strength —hence, the estimated path loss values— is typically affected by frequency-dependent multipath fading and shadowing. Especially in

indoor environments where the loss given by partitions (e.g. walls, floors) is extremely high, one critical aspect relates to the measurement of long distance links where the received signal power tends to drown into the noise. This effect is given by a combination of factors, mainly consisting in a limited sensitivity at the receivers and low Power Spectral Density (PSD) of the transmitted signal. Given the fact that the receiver sensitivity is hardware-dependent and cannot be modified, employing signals with high PSD is desirable in order to extend the measurement range. However, since a limited power is typically available at the transmitter, a trade-off between the signal bandwidth and the PSD must be established. Transceiver chains support a limited power before the signals get distorted. Even though the reference signal may not carry data, it is convenient to adopt “frequency flat” waveforms such that signal variations in frequency can be better analyzed at the receiver. With this design there is no need for post-equalization (as long as we are performing scalar - amplitude - measurements). In order to accommodate such power and frequency requirements in this project Constant Amplitude Zero Autocorrelation (CAZAC) sequences with low Peak to Average Power Ratio (PAPR) characteristics, have been employed at the transmitter

In Table 4.1 a list of the main configuration parameters for the channel sounder testbed is provided. The sampling rate for the sounding signal has been set to 12.5 MSamples/sec, compatible with the characteristics of the available RF hardware front-end (i.e. the Ettus XCVR 2450 daughterboard). The specific value of 12.5 MSamples/sec has been selected because the USRP hardware suffers of digital distortions (i.e. due to the characteristics of interpolation and decimation operations in the transceiver chains) which are minimized if the selected operating sample rate is a divider, multiple of four, of the maximum rate (i.e. 100MSamples/sec). In order to avoid operating at the bandwidth edges where the gain response is not perfectly uniform, only 10 MHz of the total bandwidth are in practice occupied and utilize for the RSRP measurements. Further, the system is design for performing independent measurements on a number of spectrum chunks, referred here as CCs). In the adopted configuration only two CCs are employed.

A fundamental assumption of the channel sounder execution mode is that the measurements are performed in static propagation conditions (further details in the next chapter). In this context, the RSRP is likely to be heavily affected by multipath fading. In order to obtain link path loss estimates free of such contribution, measurements at every testbed drops are also repeated over a range of different carrier frequencies. The minimum difference between two frequencies is set larger than the coherence bandwidth of the channel —an upper bound value of 20 MHz is assumed for indoor environments. 50 frequencies, with a separation of 20 MHz, across the band from 4.91 to 5.89 GHz have been selected. In practice the actual number of utilized frequencies is lower (varying from 38 to 44) since some carriers have been discarded due to the presence of external interferers (e.g. WiFi). Different values of TX power have been employed in the trials, i.e 0.4 dBm and 12.4 dBm. In the time domain, a single measurement frame has a

Table 4.1: Configuration parameters for the Channel Sounder application

TX sampling rate	12.5 MS/s
Signal bandwidth	10 MHz
FFT size	1024
Number of CC	2
Number of subcarriers per CC	390
Carrier Frequencies	38-44 frequencies across the band from 4.91GHz to 5.89 GHz
Total TX Power	0.4 and 18.5 dBm
TX/RX slot duration	0.164 seconds
Antenna Gain (5GHz band)	5dB
RF Cabling Loss (5GHz band)	4dB
Antenna	omnidirectional
Antenna height	1.7 meters

duration equal to 2000 blocks of samples (i.e. a block has the size of the FFT)—given the employed FFT configuration with 1024 bins, the total frame duration is about 0.164 seconds. Since the channel sounder setup performs only energy detection (and not data demodulation), TX/RX synchronization at FFT block level (or OFDM symbol level) is not required.

The software application supporting the channel sounding operations in the testbed machines has been implemented with the ASGARD platform. The realized architecture is depicted in Figure 4.8. The **UHD Communication** component, manages the streaming of data to and from the hardware. The samples of the reference signal to be transmitted are pre-generated and stored in the **TX Signal CO**. The **Data Selector** selects the valid blocks of data at every RX frame, while the **Sensing Component** performs the FFT operations and **RSRP** computation. Averaged **RSRP** values are generated for independent groups of subcarriers (i.e. **CC**). The **Time Division Sensing** is aware of the framing structure and aggregates the **RSRP** measurements over time. The overall execution of the measurement process is supervised by the **TDD Frequency Switch Controller**: this component sets the activation time for the node and is responsible for the transmission of the measurements to the Testbed Server. Furthermore, it also control the transceiver reconfiguration (e.g. the switch of carrier frequency) whenever required. The frame-level synchronization between multiple nodes is achieved by exploiting the **NTP** service of the host computers. It is assumed that all **TDD Frequency Switch Controllers** at every node can rely on a common **NTP** reference with an error of few tens of milliseconds. All nodes are also connected through a backhaul net-

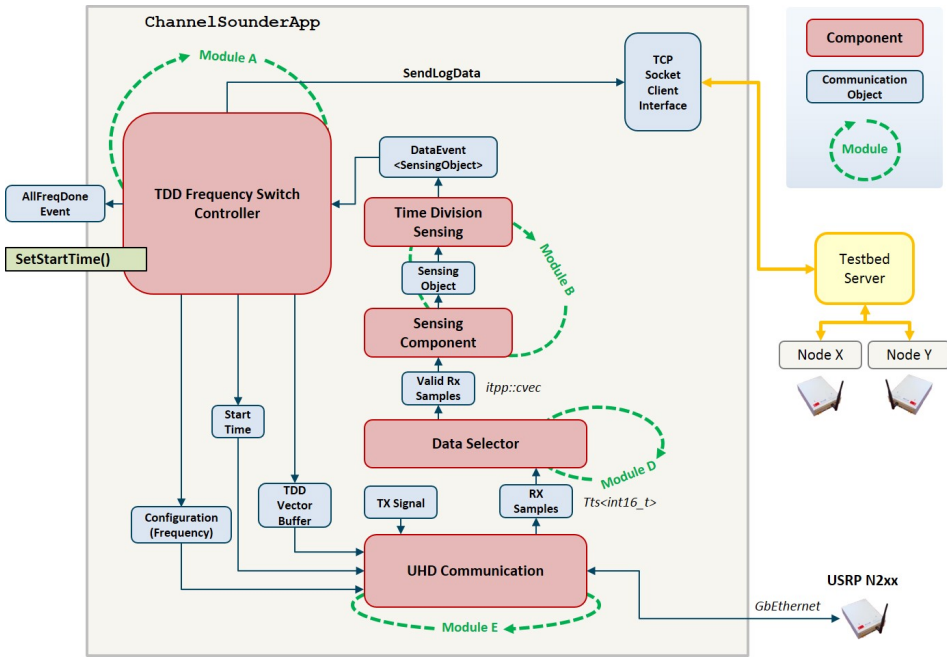

Fig. 4.8: Software architecture of the channel sounder application realized with the ASGARD SDR platform

work (either WiFi or Ethernet) to a testbed server which enables the centralized control of the devices and supervises the acquisition of measurement and logging of data. Each node independently reports its measurements while the data aggregation over multiple nodes is performed at the server.

The previously described channel sounder execution mode and testbed configuration have been employed in this thesis for the acquisition of link path loss measurements in practical indoor deployment scenarios. The measurement campaigns aimed at developing an experimental data-set which could enable the validation of distributed **FD-ICIC** algorithms by means of hybrid-simulations. Details about the selected scenarios for the measurements, as well as the analysis of the acquired path loss data will be given in Chapter 5.

4.6 Practical aspects in the testbed management

After having introduced the main methodological and procedural aspects of the experiments in this thesis, the last part of the chapter is dedicated to practical

issues in the testbed management, which also have a fundamental impact in ensuring the feasibility and reliability of trials. The following discussion applies without distinctions to both live execution and channel sounder experiments.

When developing a testbed for network-oriented wireless experiments, the number of nodes available in the testbed is a fundamental design parameter. In this context, the *cost-per-node* is a key aspect to consider when devising the best configuration for the testbed. The cost of an SDR node varies according to the characteristics and quality of its internal components: the SDR motherboard and RF front-end typically play a major role in respect, for example, to the host-PCs. Critical quality parameters for the SDR hardware are: the maximum achievable sampling rate, the resolution of the DAC/ADC, the accuracy of the internal clock and reference oscillator, the support for full-duplex transmission and MIMO configurations.

The selection of the RF components should clearly first consider the carrier frequencies targeted in the experiments. The operating bands affect the choice of the RF front end (e.g. the choice of antennas) as well as have considerably different policies for their utilization in experiments. Restrictions in the spectrum usage may vary from country to country. The RF front-end should have specifications also compliant with the expected characteristics of the employed waveforms. In particular, OFDM modulation and other waveforms with high PAPR have strict requirements in terms of quality of the power amplifier and IQ balance. Furthermore, MIMO applications may require the RF front-end to support accurate clock synchronization and precise timing control for the streaming of samples from/to the hardware. The characteristics of the hardware oscillators are then a major design parameter since both frequency (e.g. phase noise) and time (e.g. *clock misalignment, drifts*) non-idealities are due to their quality. Applications featuring time division duplexing (TDD) may also require the possibility of time-stamping the hardware samples for a time-accurate management of the data streams. Frequency division duplexing (FDD), on the other hand, requires multiple independent oscillators in order to manage multiple carrier frequencies in parallel.

There are several practical aspects which should be considered in order to ensure the reliability of results obtained with a wireless network testbed. The RF hardware characteristics, for example, can differ from device to device and tend to degrade with time. Periodical *calibration* in respect to a common reference is therefore needed. The precision of the central carrier frequency is one of the most critical aspects to be monitored since it typically made unstable by the phase noise effect and frequency offset. While the phase noise is mainly due to the oscillator characteristics and cannot be controlled, the frequency offset is semi-deterministic and can be typically compensated. Another aspect which may affect the consistency of power measurements in the testbed is the frequency response of the RX and TX chains. The power gains given by the amplifiers in the transceivers may indeed vary considerably (i.e. several dBs) in frequency thus should be compen-

sated in order to obtain a “flat” response. Frequency-specific calibration factors — independently calculated for the receiver and the transmitter— can be estimated during the calibration procedure and then applied in runtime to the transmitted/received samples to/from the hardware. Calibration procedures are typically very time-consuming. In testbed configurations with large number of nodes, repeated calibrations may become a burden in the every-day management of the experiments. For this reason, the development of automated procedures is highly recommended. Eventually, the contribution given by the employed **RF** connections and antennas should also not be overlooked. Estimating the attenuation introduced by the cabling, as well as the —frequency-dependent— gain given by the antenna radiation pattern, is indispensable for both the calibration process and the configuration of communication system parameters during the experiments.

Another problem in the practical management of the testbed, relates to the *backhaul network connectivity* during the trials. In order to control the active devices, as well as retrieving the experimental data, a form of backhaul communication between the nodes is often needed. Out of laboratory premises, it can be difficult to provide cable-based connections (e.g. ethernet) —wireless solutions (e.g. WiFi) represent a viable alternative but suffer of low coverage in indoor environments. When planning the trial execution, the availability of a sufficient amount of accessible network supplies should be verified in advance. The coverage of wireless **APs** should be tested, as well as the presence of potential interferers. Public wireless networks — where available— may also represent an option for the backhauling, however, their performance may be unpredictable due to the presence of potential external users. Whenever setting up an Internet Protocol (**IP**)-based backhaul network, the usage of a dedicated subnet with static **IP** addresses is recommended, easing the identification of the nodes. Moreover, it is also important that the testbed can be accessed from remote, allowing in this way, the control the experiments without the need of human presence in the environment. Virtual Private Networks (**VPN**) and Secure SHell (**SSH**) connections are useful tools to manage such type of access. In order to improve the resilience of the testbed to connection failures it is suggested not to access the nodes independently but rather to employ a local testbed server as an interface with the remote user.

The backhaul connection may be also critical for the *synchronization* of the nodes. **NTP** clients are available in all modern **OS** thus representing a convenient solution for synchronized testbed operations within few milliseconds of accuracy. If greater timing accuracy is needed, Global Positioning System (**GPS**) modules can be often attached onto the **SDR** motherboards. In indoor environments, however, the strength of the **GPS** signal is often insufficient (**GPS** receivers may work if antennas can be placed in proximity of windows), wired solutions with local reference clocks can be used otherwise or, alternatively, distributed synchronization mechanisms should be implemented with the hardware.

From the practical experience acquired in this project, it has been verified that the

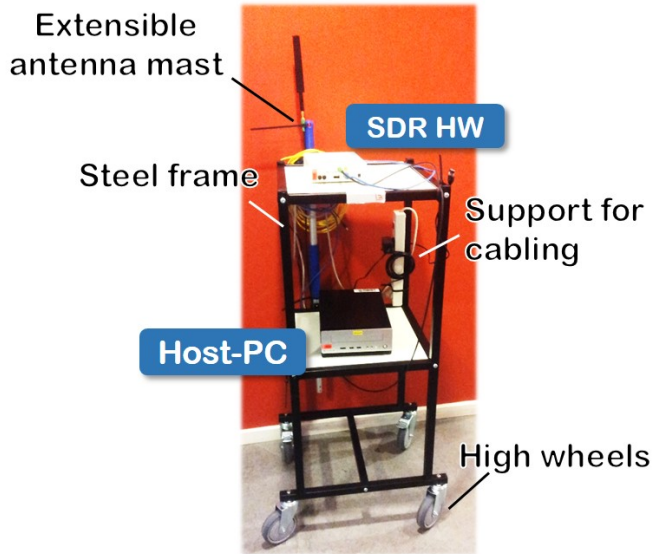

Fig. 4.9: Hardware setup for movable testbed nodes.

time required to relocate the testbed equipment over multiple trials is extremely demanding. In this respect, *movable trolleys* may provide a useful solution for easing the re-deployment —as well as the mobility— of the nodes. A picture of the setup specifically realized for experiments in this thesis is provided in Figure 4.9. A solid steel frame has been designed, ensuring the safety of the equipment when moving. The frame supports the loading of heavy parts (e.g. car-type power batteries) and it can be easily dismantled for transportation purposes. High wheels with safety breaks have also been added, easing the movement of nodes in outdoor terrain conditions. The trolleys support the storage of all cabling components (i.e. power, network and RF cables) and an extensible mast is attached enabling the positioning of the antennas at variable heights. The dimensions of the trolleys are 45x45x110 cm thus constituting a trade-off between the necessary space to load the equipment (considering also the possible presence of portable batteries and multi-board SDR configurations) and a size-factor which will not impede the movement in indoor environments.

4.7 Summary

In this chapter practical methodologies and approaches for the experiments execution have been discussed, aiming at enabling the experimental validation of distributed network schemes in local area scenarios. Terminology has been first

defined —objectives of the trials have been thoroughly discussed, in order to identify major challenges in the setup and execution of the trials. Two experimental approaches have been defined, focusing in particular on the performance validation of distributed **FD-ICIC** algorithms. The *live execution* of concepts, allows to evaluate the runtime execution aspects of the systems thus it is particularly suited for the analysis of time-varying phenomena. Major limitations for the live execution relate to the practical difficulties in analyzing a large number of network topologies and configuration parameters. In order to overcome these problems, a second approach based on *hybrid-simulations* has been devised —relying on multiple testbed re-deployments in order to increase the number of nodes spatial positions considered. Hybrid-simulations aim at bridging the gap between system-level simulations and the experiments, in order to enable the comparison of results. Eventually, practical aspects related to the configuration and management of the testbed hardware have been also discussed, providing solutions for the agile execution of experiments as well as ensuring the reliability of results.

Link path loss in indoor deployment scenarios

5.1 Introduction

In cellular networks, the reliability of simulation-based performance studies, greatly depends on the capabilities of the employed scenario and propagation models, of accurately reproducing the conditions on the links, of real network deployments. In this chapter, the differences between simulation scenarios and practical deployments have been analyzed, relying on link path loss (PL) measurements collected with the channel sounder testbed. The objectives of the analysis are twofold: —one— understanding the limitations in the usage of common stochastic path loss models for the description of the single-link —two— establishing under which extent the path loss and scenario models are able to describe the multi-link characteristics of a network deployment.

5.2 Measurement campaigns in indoor environments

Applying the methodology previously described in Section 4.5.3, multiple path loss measurement campaigns have been carried out in indoor deployment scenarios. In

this respect, environments with different propagation and geometrical characteristics have been selected, aiming at creating different data-sets for hybrid-simulation purposes:

- *Indoor Office* - Targeting dense small cell deployments across common office premises, a scenario with two rows of adjacent rooms separated by a corridor has been first selected. In Figure 5.1.a, it is depicted the layout of the selected location, at the ground floor of a building at the Aalborg University campus. This scenario will be referred in the text as **NJV12**. The area of the NJV12 scenario is characterized by rooms whose size varies between 2.5-7.5 meters of width and 5.5-7 meters of length. A large number of concrete and plaster walls divide the rooms, thus representing a major factor affecting the signal propagation in the environment. Moreover, the entire area is characterized by the widespread presence of clutter (i.e. office furniture, scaffolding, black/white-boards).
- *Open Area/Mall-type* - A second scenario with different propagation characteristics has been also analyzed —aiming at evaluating deployment configurations where a high number of Line of Sight (**LOS**) links in the network. The **NJV14** scenario, depicted in Figure 5.1.b, distinguishes from the *NJV12* for its larger dimensions. A central hall with triangular shape and area of about 300sqm is present in the middle; the hall ceiling is about 10 meters high. Two sides of the hall are surrounded with large rooms of variable size while the third side is delimited in large part by glass surfaces.
- *Single-room* - In addition to the first two scenarios, a third measurement trial has also been conducted in a large room in order to obtain further data samples related to short-distance links in **LOS**. The location selected for the trial has been the large room in the lower left corner of the NJV14 scenario.

The campaign in the NJV12 office scenario considered 45 different spatial locations to be measured, highlighted by the red dots in Figure 5.1a. In order to evaluate the deployment of small cells which are physically confined within a closed space, positions for both **APs** and **UEs** have been defined within the perimeter of the rooms. Aiming at obtaining a data set where positions are spread homogeneously across the available space, and considering spatial modules of dimensions 3x6 meters (corresponding to the average room size), 3 positions per module have been identified, with an inter-node distance varying from 2 to 2.5 meters. Following a similar principle, 48 locations have been identified across the NJV14 scenario and are reported in Figure 5.1b. In this case the spatial sampling targeted mainly the central hall while additional positions have been defined in the surrounding rooms. The single-room trial involved 16 node positions regularly spread across the area, with an inter-node distance of about 2.5 meters.

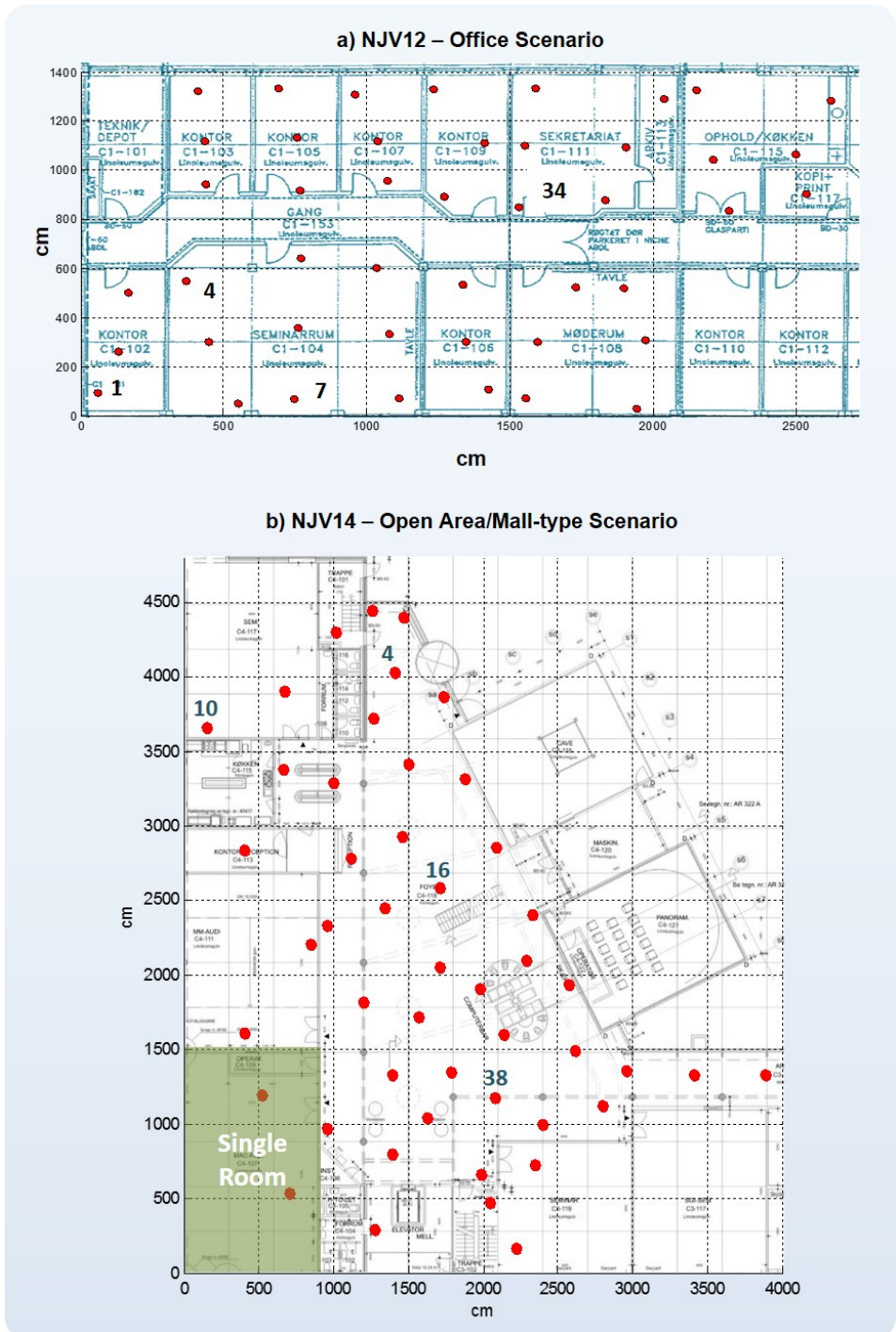

Fig. 5.1: Overview of the NJV12 Office and the NJV14 Open Area/Mall-type scenarios. The Single Room scenario is highlighted in the green area. The red dots represents the node positions analyzed with the testbed. Specific locations utilized in the discussions of this chapter, have been highlighted with the ID number utilized during the trials.

5.3 Estimating the path loss

In order to calculate the path loss, we are interested in the ratio between the transmit power of the reference signal, and the power measured at the receiver. In the channel sounder testbed, **RSRP** estimates are generated by measuring the numerical values retrieved from the hardware, without calibrating against the power in mW—the obtained values are then retrieved as *unscaled* dB [udB]. A single **RSRP** estimate is the result of multiple averaging operations performed both in time and in frequency. According to the configuration previously described in Section 4.5.4, power measurements are first performed over the multiple subcarriers within each of the system **CCs**, and then averaged across multiple **CCs**. As a result, a single **RSRP** measurement—and consequently the **PL**— is averaged over the entire operating channel bandwidth (i.e. 10 MHz) thus canceling out the effect of the fast-fading within this interval. Multiple measurements in frequency are then repeated in time, the duration of a single RX slot (i.e. about 164 ms, Figure 4.7).

The final path loss values are then obtained from the **RSRP** estimates by considering a reference value of transmission power measured in the lab:

$$PL[dB] = Pow_{ref}^{TX}[udB] - RSRP_{measured}[udB]$$

The obtained averaged reference path loss values for all links are displayed in Figure 5.2, with different colors for the considered scenarios. The scatter plot highlights differences in path loss range and link distances. On average, links in the NJV12 Office scenario are characterized by short distances—from 2 to 20 meters—with relatively high path loss due to the large number of partitions and clutter present on the link paths. Differently, the NJV14 Open Area/Mall-type scenario is characterized by links covering larger distances—up to 44 meters—but not corresponding large path loss, due to the presence of many links in **LOS**. Finally, path loss values measured in the single-room appear to be in line with similar type of links measured in the NJV12 and NJV14 scenarios.

5.4 Critical analysis of the data

In order to utilize the acquired path loss data for hybrid-simulation purposes, it is first important to discuss under which extent the measurements provide an accurate description of the wireless links in the considered scenarios. Given the limitations of the testbed hardware in comparison to dedicated channel sounding instrumentation, the statistical properties of the measurements have been discussed aiming at a qualitative analysis about their reliability.

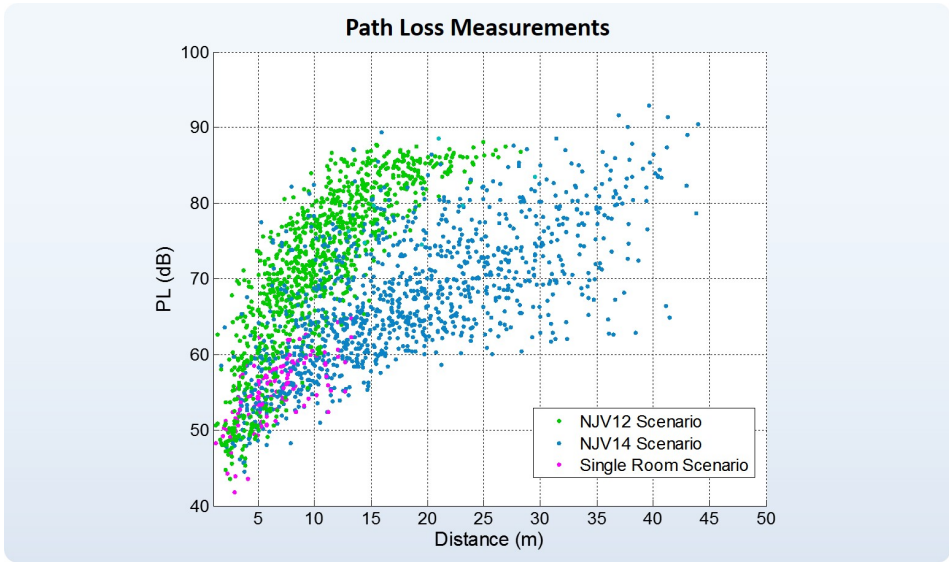

Fig. 5.2: Measured link path loss for the considered deployment scenarios.

Visual examples of the obtained path loss data have been reported in Figures 5.3 and 5.4: frequency-domain PL estimates for significant links in both the NJV12 and NJV14 scenarios are displayed. The links considered in the examples are representative of both LOS and Non-Line of Sight (NLOS) conditions, as well as different distances and number of wall crossings on the paths. The PL values are reported in terms of final time average, differentiating across the set of carrier frequencies employed in the measurements. 44 carriers have been utilized for the NJV12 scenario, 38 carriers for NJV14. In both cases, the frequency range spans from 4.91 to 5.89 GHz.

According to basic physics, a $1/f^2$ dependency —due to propagation coupling losses— should be experienced by the RSRP measurements in the frequency domain. In the considered range, this would correspond to a PL increase of about 1.58 dB from the lowest to the highest carrier frequency index. The analysis of the data did not allow, however, to verify this effect. The explanation has to be found mainly in the super-imposed effect of variable antenna gains in frequency. The antenna gain may indeed impact the RSRP measurements significantly, e.g. comparing to the coupling loss. Unfortunately, due to the lack of accurate documentation about the employed antennas (i.e. omni-directional dipole antennas, commonly utilized for WiFi APs), a more detailed analysis could not be performed.

The standard deviation for the PL measurements in the frequency domain (i.e. obtained considering multiple measurements, for the same link, at different carrier

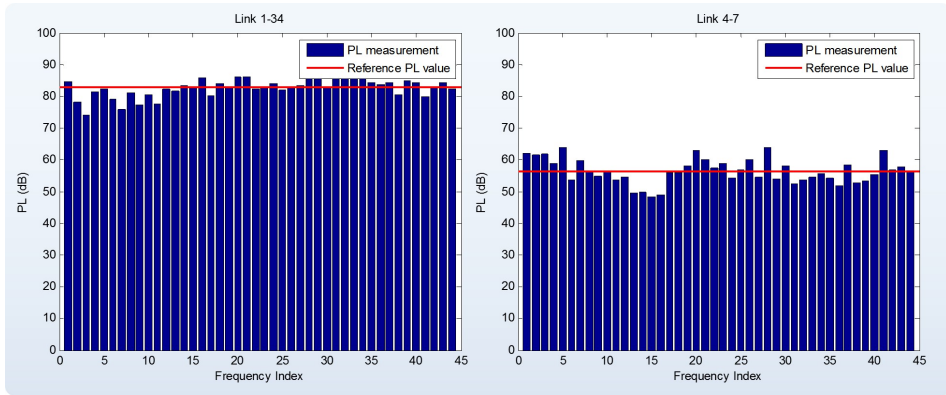

Fig. 5.3: Measured PL values in the NJV12 scenario for different carrier frequencies (i.e. 44 carriers from 4.91GHz to 5.89GHz). Values are shown for the link 1-34 (19.66 meters, 5 wall crossings) and link 4-7 (6.1 meters, LOS).

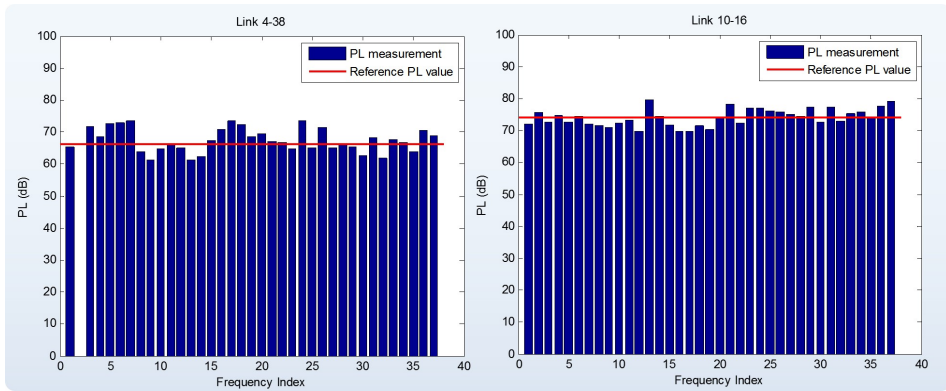

Fig. 5.4: Measured PL values in the NJV14 scenario for different carrier frequencies (i.e. 37 carriers from 4.91GHz to 5.89GHz). Values are shown for the link 4-38 (29.3 meters, LOS) and link 10-16 (18.86 meters, 1 wall crossing).

frequencies) is shown in Figure 5.5 in the form of CDF. Results are displayed by differentiating between the LOS and NLOS links in the NJV12 and NJV14 scenarios. By observing the data a relatively low deviation is generally experienced (i.e. mainly in the range of 2-4 dB) for all considered cases. In the NJV12 Office scenario, differences exist between the LOS and NLOS links: in the latter, the typically more complex propagation —due to the possibility of having diversified signal paths across the office rooms, e.g. through walls, doors, corridor and external paths through the windows— leads to a greater variability of the RSRP thus a larger deviation of the PL estimates. On the other hand, the geometry of the NJV14 building is likely to impede the generation of highly diversified paths (e.g. paths external to the building, as it can happen through the windows of adjacent

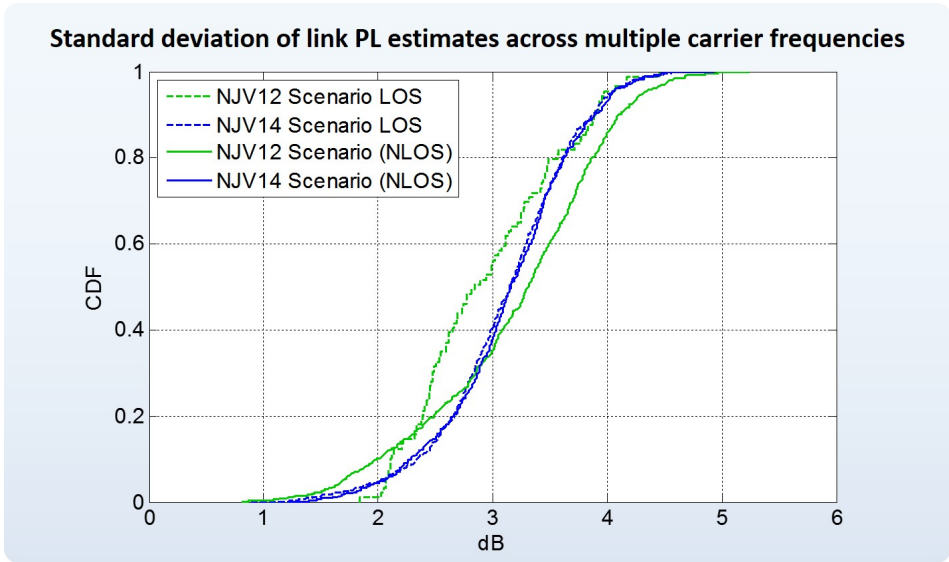

Fig. 5.5: CDF of the standard deviation of the link PL measurements in the frequency domain. A single point in the CDF corresponds to the standard deviation of multiple carrier-frequency measurements, in respect to a single link

rooms in the office scenario). In this case, both LOS and NLOS links show very similar standard deviation statistics. Such kind of behaviors well fit with the expectation that the total power in LOS tends to be dominated by a stable direct component, while less by (random) multipath contributions. Finally, in relation to the tail of the CDFs, showing a low std. deviation, the analysis of the data reveals these points to be mostly relating to links with high PL values, corresponding to situations where the RSRP tends to drown into the noise.

Another aspect which concerns the reliability of the path loss data, is the variability of the measurements across multiple runs. According to the channel sounder execution mode, multiple runs are indeed employed for the measurements, during which partial re-deployments of the testbed nodes are performed. The results shown in Figure Figure 5.6, in terms of link PL standard deviation across multiple runs, show that thanks to the static environment assumption —as well as the accurate positioning of the nodes over time— the variability introduced is very limited. The standard deviation does not exceed 2.5 dB at the 95-th percentile. To summarize, the variability of the data in the frequency domain —due to multiple causes, e.g. multipath, antenna gain— appears to be of greater importance, for the evaluation of the path loss estimates reliability, than the multi-run characteristic of the measurement procedure.

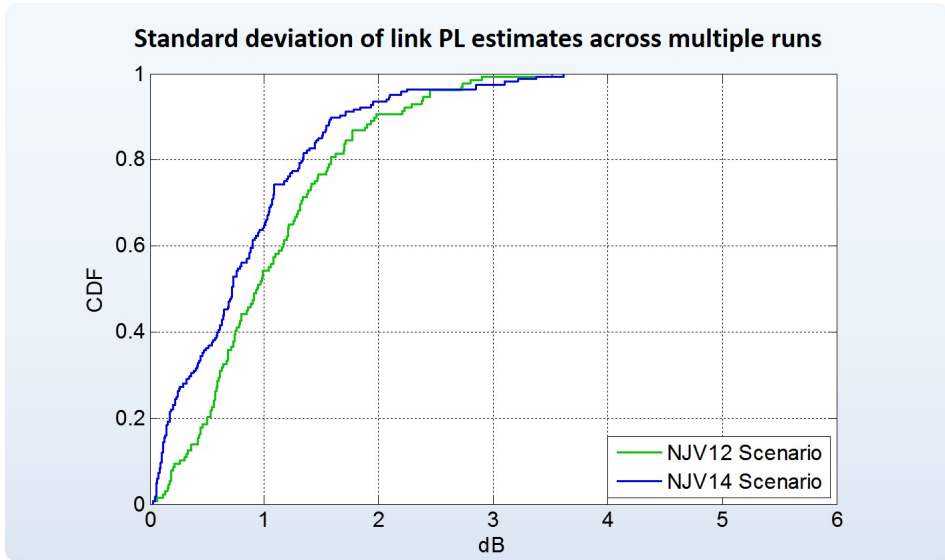

Fig. 5.6: CDF of the standard deviation for the *RSRP* measurements utilized in the computation of path loss on the links. Each point on the CDF relates to a unique link measurement.

5.5 Path loss modeling

The path loss model is one of the key elements in the description of a network deployment scenario in simulations. The accurate prediction of the path loss is critical for the analysis of the single-link system performance, as well as it affects larger-scale multi-link aspects, e.g. the ratio between useful signal and the interferers in a cellular network. In order to understand the differences between simulated deployment scenarios and the experiments, the path loss prediction capabilities of common stochastic path loss models are first analyzed in this section of the chapter. The acquired path loss measurements in the NJV12 and NJ14 scenarios provided a large data set for the analysis, allowing to evaluate the path loss model predictions in both indoor office and open-area conditions.

In this section, the discussion focuses on the WINNER II family of channel models [65], which has been selected reference for parametric path loss models due to its wide employment in simulation-based studies for the evaluation of indoor small cells deployments. According to the WINNER II documentation, multiple types of model are described—to be used with different propagation environment assumptions. All models are derived from a formulation of the form:

Table 5.1: Winner II path loss models parameters (from [65]). n_w indicates the number of wall crossing along the direct link path.

Scenario Type	Model Parameters				Sh. Fad. std [dB]
	A	B	C	X	
A1 Indoor Office/Residential					
LOS	18.7	46.8	20	-	3
NLOS (corridor-to-room)	36.8	43.8	20	$5(n_w - 1)$	4
NLOS (room-to-room)	20	46.4	20	$5n_w$	6
B3 Large Hall					
LOS	13.9	64.4	20	-	3
NLOS	37.8	36.5	23	-	4

$$PL = A \log_{10}(d[m]) + B + C \log_{10} \left(\frac{f_c[\text{GHz}]}{5.0} \right) + X \quad (5.1)$$

where A parameter accounts for the path loss exponent, B is the intercept, C describes the path loss frequency dependence and X is an optional term which can be related for example to the attenuation generated by walls. Specific values for the A, B, C and X parameters are specified in [65] for different environments. In this project, the indoor *office/residential* and *large hall* configurations have been considered the most relevant. The reported values for the path loss models parameters are displayed in Table 5.1. An important distinction is made in the model for distinguishing between **LOS** and **NLOS** links.

In order to evaluate the prediction error given by the WINNER II models, all measured links, in all scenarios, have been characterized for distance and number of wall crossing (n_w) in order to compute the residuals in respect to the measured path loss value. As a general principle, the number of crossing has been determined by analyzed the direct path connecting two spatial positions and counting the number of intersections along the path. However, in those situation where a clear intersection case could not be established (e.g. path crossing the edge of a corner, columns) an empirical criteria has been adopted, aiming at not penalizing excessively the **PL** computation on links where high **RSRP** levels suggested the presence of non-direct paths for the signal. While the geometrical characteristics of the NJV12 office scenario made intuitive the process of computation of wall crossing, the large NJV14 scenario proved to be more challenging due to the presence of several building irregularities. The obtained residuals for all considered points

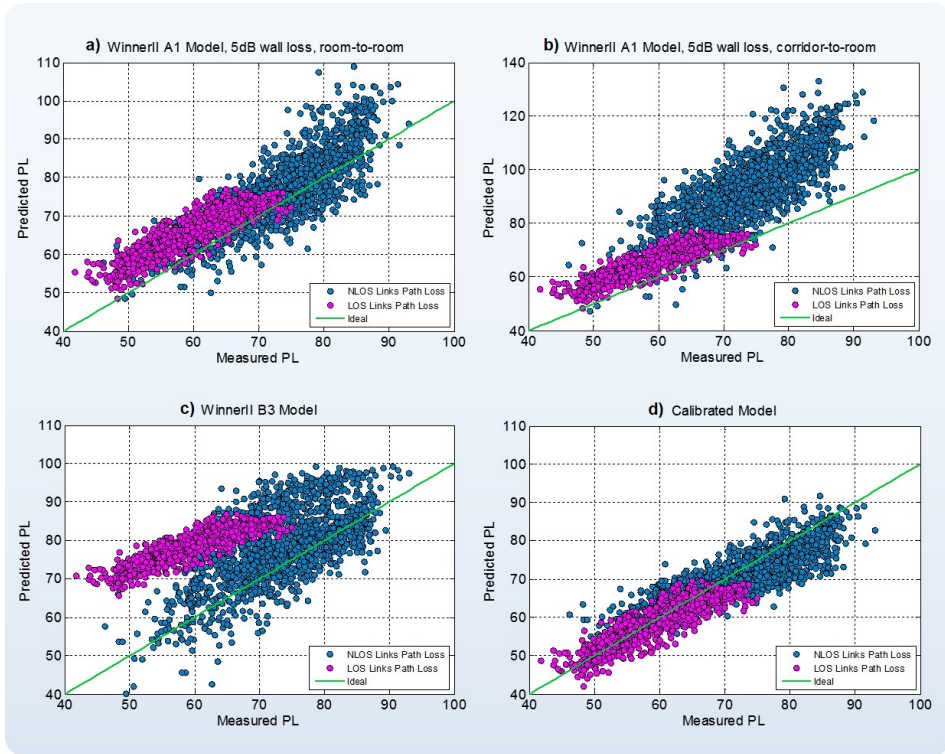

Fig. 5.7: Plot of residuals between predicted path loss values with different models and the actual measurements in the considered scenarios (NJV12, NJV14 and Single Room). The green line represent the ideal prediction with no error.

(i.e. NJV12, NJV14 and Single Room scenarios) have been plotted in Figure 5.7. The ideal prediction is highlighted in the plots by the green line; LOS and NLOS links are shown in different colors.

In general terms, the WINNER II models do not predict accurately the path loss on the selected links. The A1 Office model with room-to-room NLOS and 5dB of wall penetration loss provides the best accuracy overall (Figure 5.7.a): LOS points seem to suffer by an almost constant offset, while a greater error is introduced for the NLOS. Using the corridor-to-room option for the NLOS further increases the inaccuracy (Figure 5.7.b). Poor accuracy for the LOS is obtained by employing the B3 model which should be applied to large hall scenarios (Figure 5.7.c): while this behavior can be expected for the Single Room and NJV12 Office points, the same kind of inaccuracy also applies to the NJV14 LOS links which are mostly related to the large hall.

Sources for inaccuracies and discrepancies between the predicted path loss val-

ues and the measurements, should be found both in the site-specific propagation characteristics of the environments analyzed (i.e. peculiar geometry, building materials), as well as in the antenna setup employed which may be responsible of introducing a constant offset in the estimated values. For the B3 case, for example, the model specifications assume a height difference of about 5 meters between the terminals (e.g. the AP and the UEs). In the measurements, omni-directional antennas placed at 1.7 meters of height have been used instead.

Table 5.2: Calibrated NJV1214 path loss models parameters

Link Type	A	B	C	X	Sh. Fad. std [dB]
LOS	18.04	41.16	20	-	3.54
NLOS	13.74	49.84	20	$3.37n_w$	4.64

By applying a linear regression on the measured values, a calibrated version of the WINNER model has been obtained, specific for the considered experimental scenarios. The calibrated path loss model parameters are reported in Table 5.2. The plot of the residuals in respect to the measurements is show in Figure 5.7.d. As it could be expected, the calibrated model achieves a far better accuracy than the previously discussed WINNER II models. All points LOS, NLOS from all scenario fit equally well. The residuals error standard deviation (i.e. 3.54 for LOS and 4.64 for NLOS) can be utilized as shadow fading parameter in the model. The calibrated path loss model is —not surprisingly— best suited at predicting the path loss in the considered environments than the WINNERII. Its contribution should be mainly perceived as a useful tool for better comparing the results of ex

As it concerns the frequency-dependency of the calibrated model, curves for significant carrier frequencies in the 5 GHz band have been plotted in Figure 5.8 (only LOS links have been considered for clarity). As shown in the plot, the offset introduced by the carrier frequency shift is extremely limited in the considered range, i.e. about 1-2 dB.

5.6 Impact of path loss and scenario modeling on multi-link performance aspects

When focusing on the characteristics of a wireless network deployment, the single-link description is only one part of the picture. In particular, although calibrated path loss models can achieve a very good accuracy in the point-to-point domain, the analysis of multi-link network relationships is typically much more complex. In literature, studies aiming at the more accurate modeling of multi-link effects

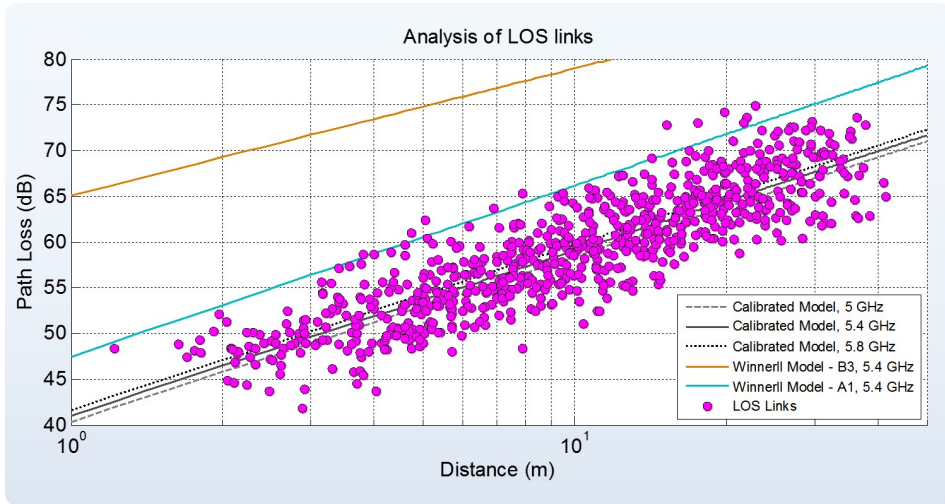

Fig. 5.8: Measured path loss values for LOS links and comparison with reference path loss models.

in network deployments, can be found in relation to the problem of correlated shadowing. A good overview of such studies is provided in [69].

Over the single link, the prediction error introduced by the previously discussed path loss models is significant, in the order of tens of dBs in the worst cases. Stochastic models are however not intended to accurately describe location-specific conditions. They rather provide a statistical representation of the environment propagation effect to be evaluated over a large number of realizations. In order to understand what is the effect of path loss modeling inaccuracies on the network performance, an analysis based on path loss statistics and performance metrics (e.g. the SINR) is proposed in this section.

In Figure 5.9 results are reported from hybrid simulations where random deployments of APs and UEs have been considered over the physical positions measured in the NJV12 Office Scenario (Figure 5.1.a). Deployment statistics have been generated considering the real measured path loss values on the links as well as the path loss prediction obtained from the Calibrated path loss model and the WINNER A1 Model. 10 cells where both AP and UE are confined within physical rooms have been analyzed. The CDFs of Figures 5.9.a and 5.9.b show that the calibrated path loss model describes more accurately the deployments characteristics in comparison to the WINNER II A1 Model. The calibrated model achieves better accuracy when modeling the UE-to-Interferer links, which in the NJV12 scenario are exclusively in NLOS. Less accurate results are instead generated for the UE-to-Serving AP links which are in LOS and short range. The better modeling of

the link path loss is reflected also in the network performance which in Figure 5.9.c has been analyzed in terms of downlink SINR at the users in the cells for a frequency scheme Reuse 1 (i.e.all APs occupy the entire set of available spectrum resources). The simulated deployment with the calibrated path loss model more closely describe the performance experienced with the measured path loss values, while by employing the WINNER II A1 model an error up to 7-8 dBs in the lower part of the CDF is detected.

A similar analysis has been conducted also in relation to the NJV14 Open Area/-Mall Type scenario, with results shown in Figure 5.10. The hybrid simulations considered 500 random deployments of 12 cells where AP have been placed in LOS along the walls of the main central all in Figure 5.1.b and the UE scattered across the entire scenario. Open Subscriber Group (OSG)-type of cell affiliation where the user connects to the strongest AP has been considered. As for the Office Scenario case, the calibrated model generally provides a better path loss prediction than the WINNER II A1 (Figure 5.10.a and 5.10.b) although greater inaccuracies are experienced in modeling the UE-to-Serving AP links. Given the predominance

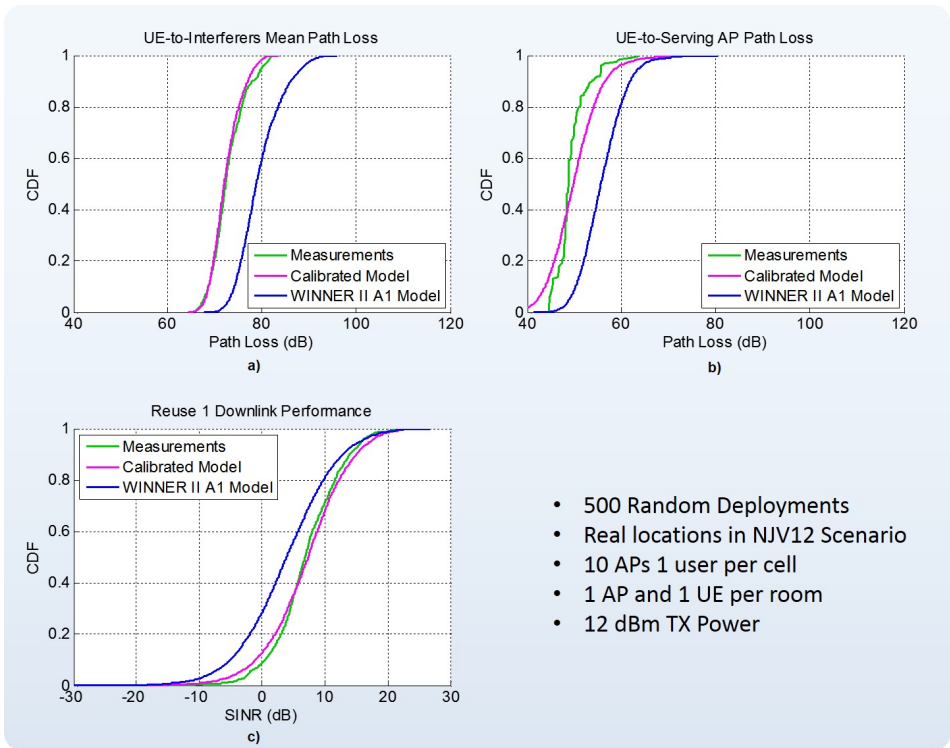

Fig. 5.9: Statistics related to 200 random network deployment in the NJV12 scenario.

of LOS links in the deployment and the similarity in path loss exponent of the calibrated and WINNER II models for the LOS case, the path loss statistics show an almost constant offset both in the prediction of the serving AP and the interfering links. Non-surprisingly this effect translates into very similar results in terms of downlink SINR at the users (Figure 5.10.c). Both models however fail in accurately describing the outage users performance, mainly due to the over-estimated path loss in respect to the serving AP.

5.7 Scenario models comparison

The objective of the measurement campaigns is to acquire information about practical network deployments in order to validate performance results obtained with system-level simulations. Differences in terms of building geometry and channel propagation may hinder however the direct comparison of results between non-

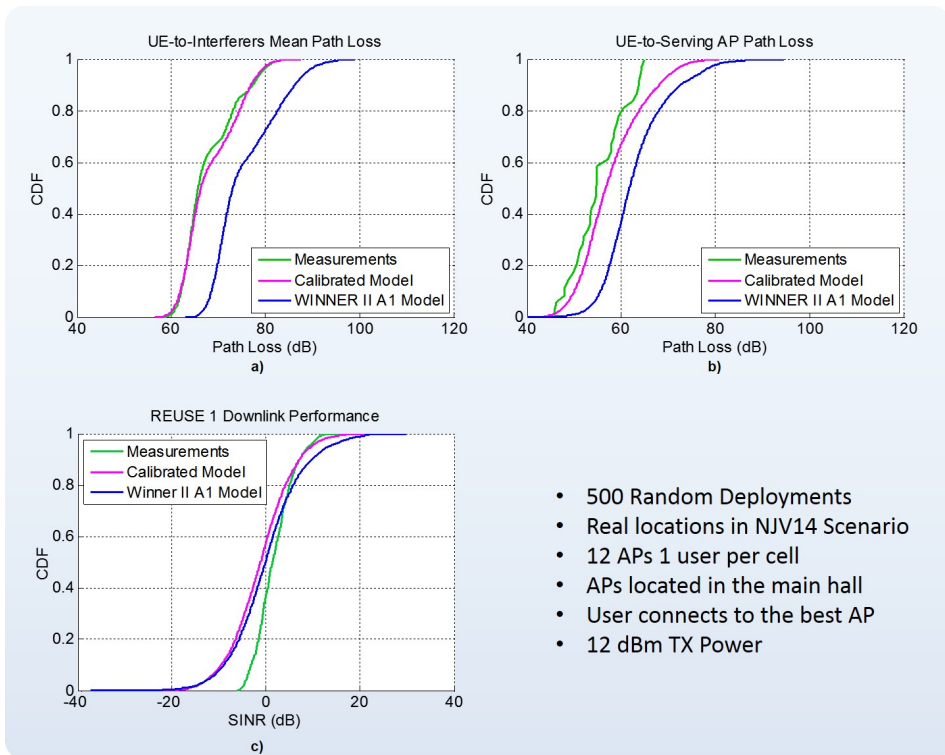

Fig. 5.10: Statistics related to 500 random network deployment in the NJV14 scenario.

homogeneous scenarios. For this reason in this section a specific analysis is carried out, focusing on the impact of scenario model assumptions in the network performance. An indoor office/residential type of scenario has been selected as the target of the analysis. The main goal is to understand whether the results of the measured NJV12 scenario (Figure 5.1.a) can be used to validated simulation-based studies with the models previously described in Section 5.5 (i.e. WINNER A1 Office and 3GPP Dual Stripe).

The NJV12 scenario is smaller in dimensions and number of cells which can be analyzed, in respect to the WINNER A1 and the 3GPP Dual-stripe. In order to bridge this gap two intermediate scenario models have been defined and used as terms of comparison. In Figure 5.11 Scenario A and Scenario B are depicted. The main criteria for the definition of these models has been to adopt common geometrical characteristics with the NJV12 scenario and the WINNER A1/3GPP Dual-Stripe, that is a configuration with two stripes of rooms separated by a corridor. The dimensions of Scenario A (rooms 6x3m, corridor 2 m) are defined to more closely resemble the configuration of the NJV12 building. Scenario B is instead an enlarged version of Scenario A where the dimensions (rooms 10x10m, corridor 5 m) are comparable to the WINNER A1 and Dual Stripe models. Both scenarios are single-floor.

The comparative analysis considers 500 random network deployments in all the three scenarios. 10 active cells where 1 AP and 1 UE are located inside the rooms are assumed per deployment. For the link path loss computation, Scenario A employs the Calibrated model of Table 5.2 while Scenario B utilizes the WINNER II A1 (Table 5.1). A minimum distance of 2 meters between the UE and the serving AP has been enforced, in order to be consistent with the minimum distances of the measured locations in the NJV12 scenario.

The obtained results in terms of deployment statistics and SINR are shown in Figure 5.12. As it can be expected, due to the larger size of the rooms, the UE-to-Serving AP link path loss is generally higher in Scenario B comparing to Scenario A and NJV12 (Figure 5.12.a). Scenario A shows higher mean path loss in relation to the interfering links (5.12.b), since on average an higher number of wall crossing is present. Furthermore, despite a comparable number of wall crossing, even larger path loss values are present in Scenario B due to the greater link distances.

Notwithstanding the differences in terms of path loss on the links, the SINR results shown in Figure 5.12.c are surprisingly well aligned for all three scenarios. The best match is obtained for the lower part of the CDFs, corresponding to low SINR users typically suffering of strong interference. Greater differences are instead experienced in relation to the best users in the upper part of the CDFs. Understanding the reasons leading to similar performance between simulation models and the measured scenarios is extremely interesting since it can provide significant guidelines for the result validation of network deployments with experimental

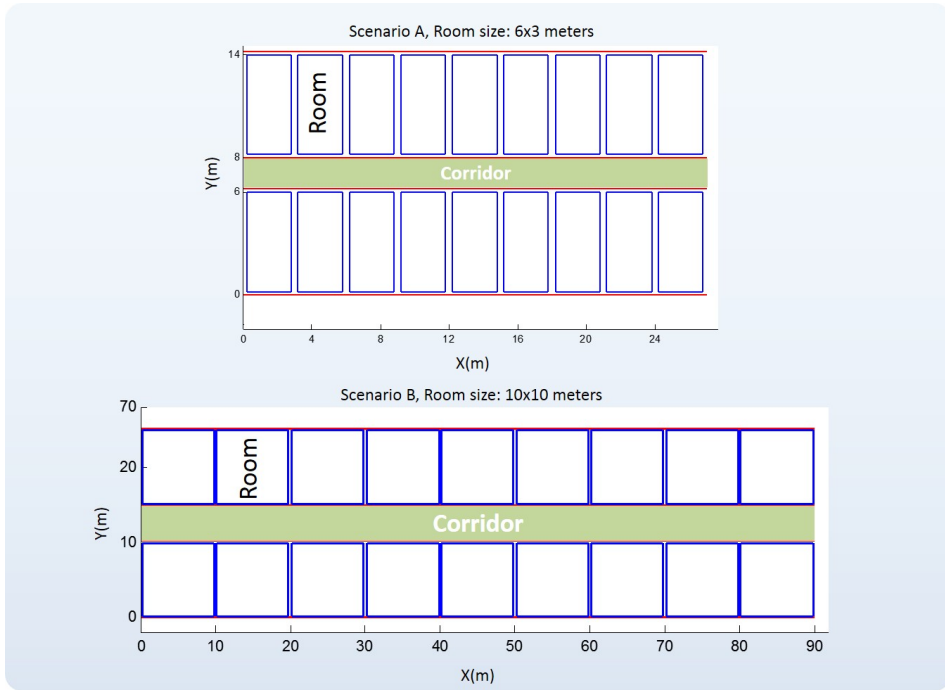

Fig. 5.11: Scenario models utilized for the comparison with the NJV12 Scenario

trials. In this context, additional results have been provided in Figure 5.12.d focusing on the 5-th percentile and best $SINR$ users of Figure 5.12.c. The analysis aims at investigating how big part of the $SINR$ variations are actually driven by the interference component. Due to the common geometrical characteristics of all three considered scenarios (i.e. each room is physically connected to max 2 rooms plus 1 in the opposite side of the corridor), it is reasonable to expect that the $SINR$ of low-performing users is given by the presence of three spatially closed interfering cells. The metric utilized compares therefore the Signal to Interference Ratio (SIR) calculated in respect to the 3 strongest interferers over the total $SINR$ value. For the 5-th percentile users the SIR approaches 100% of the $SINR$ as expected. The performance of best users instead, typically relates to interference-isolated cells where the geometry of the strongest neighboring interferers is of lower relevance. The SIR -to- $SINR$ ratio shows indeed non-correlated performance between the three scenarios. For the best users case, the scenario size and the average number of wall crossing have a dominant role in determining the probability of having a spatially isolated cell and thus high $SINR$ values.

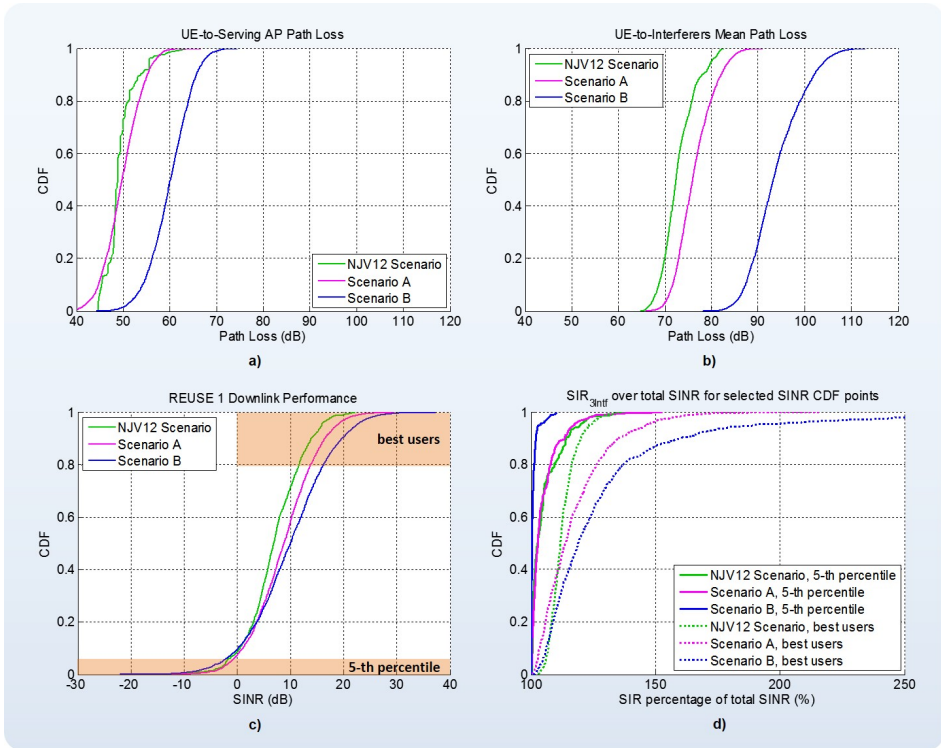

Fig. 5.12: Statistics about 500 random cell deployments in the scenarios NJV12, A and B. 10 cells, 1 AP and 1 UE per cells. 12 dBm Tx Power.

5.8 Discussion

The path loss measurements collected in this project show that differences exist when analyzing the characteristics of practical network deployments rather than simulated scenarios. Common stochastic path loss models are in general not a reliable method for predicting location-specific phenomena. Adopting a calibrated model can provide significant improvements, however, even small inaccuracies can lead to substantial differences in the network performance statistics when the impact of a multiple cells is considered. When looking at the statistics of random network layouts across different scenarios, the building geometry (e.g. dimensions, disposition of internal partitions/walls) play a major role in shaping the interference characteristics. In particular, in residential/office context where the presence of walls has a predominant effect on the links path loss, comparable scenario geometry leads to similar performance results. This appears to be true, especially for those users suffering of high interference conditions. The maximum dimensions of the scenarios affect the probability of having fully isolated cells, thus primarily

impact the performance of the best cases of the users distribution. Results obtained in this chapter, suggest that network deployments in a Dual Stripe-type of scenario model, have very similar properties to deployments in the NJV12 office scenario. For this reason, we expect that the performance of network algorithms obtained in the NJV12 scenario, can be utilized as term of comparison for the validation of simulation-based studies relying on the Dual Stripe model.

Validation of distributed concepts for local area wireless networks

6.1 Introduction

The objective of this chapter is to apply the testbed and execution approaches, previously described in this thesis, to the experimental validation of distributed network concepts. The main focus of the experiments is on algorithms for frequency-domain inter-cell interference coordination (**FD-ICIC**) in local area small cells. The chapter starts with a brief overview of **FD-ICIC** mechanisms. A specific algorithm, named **ACCS**, has been selected and it is discussed as the main target of the experimentation. Afterwards, the realization of an **SDR** testbed for **ACCS** is described as well as the practical execution of trials. Eventually, performance results are analyzed and compared to prior work for the validation of simulation-based studies. Furthermore, as an example of the application of the developed experimental tools and methodologies to other distributed concepts for local area, the last part of the chapter also introduces two early activities with **IRC** receivers and distributed synchronization algorithms.

6.2 Inter-Cell Interference Coordination in local area small cells

The ultra-dense deployment of small cells is expected to be a major characteristic of next-generation 5G wireless networks, promising to deliver better performance in terms of capacity, coverage, spectral efficiency and power consumptions [1]. Assuming all tiers of the network to be sharing the same licensed spectrum, interference-limited scenarios are expected to arise. The achievement of the ambitious 5G performance targets will then necessarily rely upon the proper management of interference, at all tier levels (i.e. intra-tier, inter-tier). In local area, two main challenges hinder the interference management. Firstly, assuming that the APs can be directly deployed by the users inside their private premises, the topology of the network may be totally unpredictable. Secondly, the difficulties in providing ubiquitous, fast, backhauling, may prevent the utilization of centralized approaches to the resource management. Considering such assumptions, a number of solutions are currently being investigated for interference mitigation purposes [70]:

- Coordinated Multi-Point (CoMP) transmission, joint scheduling
- Interference Coordination
- Interference Rejection based on advanced receivers

The principle of CoMP is to coordinate the transmission of multiple Base Station (BS)s as such that improved signal quality can be achieved by the users. As joint scheduling, it is intended solutions for the network-side link adaptation, in which, for example, transmission rates and schemes of multiple cells are not independently determined [70]. Interference coordination solutions aim at mitigating the interference generated by neighboring cells by orthogonalizing the occupied resources, either in time, space (e.g. beamforming) or frequency. Differently, interference rejection/cancellation mechanisms exploit advanced PHY-layer features (i.e. multiple antenna systems, advanced receivers) to suppress the contribution of interfering signals thus improving the effective SINR. Due to the complexity and cost-effectiveness concerns (i.e. the possibility of implementing distributed approaches and relying on advanced PHY capabilities at the terminals), interference coordination and interference rejection approaches have been identified in this thesis as of primary interest.

6.2.1 Inter-Cell Interference coordination in the frequency domain (FD-ICIC)

The process of resource management in a wireless network aims at providing the necessary capacity to the users in order to satisfy their variable needs in terms of data traffic. RRM algorithms in cellular networks need typically to accommodate various type of demands when allocating resources:

- The balance between UL and DL transmissions.
- The resource competition between multiple UEs connected to a single AP.
- The coexistence of neighboring cells operating over the same resources.

In WiFi systems, the presence of a CSMA/CA medium access scheme provides a form of distributed time-domain multiplexing, which allows to avoid the problem of co-channel interference. Multiple nodes, regardless of their role, implicitly coordinate their access to the spectrum through a contention-based process which allocates —*de-facto*— orthogonal time intervals for multiple transmissions. In a cell-centric system instead, multiple cells have, generally, uncoordinated UL/DL transmissions in time. In this context, managing the inter-cell interference in the frequency-domain is likely to be more effective. Most of the specifications for cellular systems are based on reuse-one spectrum allocation, where multiple cells utilized the entire available bandwidth for transmission. FD-ICIC solutions improve the coexistence between densely deployed cells, by enabling a flexible reuse of their spectrum resources according to their level of interference-coupling. The inter-cell resource sharing typically operates at higher-level and on a slower basis compared to intra-cell allocation schemes. For this reason, FD-ICIC solutions can ensure the necessary compatibility with traditional user scheduling mechanisms in cellular systems.

From the performance perspective, recent studies [71] have shown that CSMA/CA-based cellular solutions are in general not able to outperform simple frequency-domain alternatives, when proper frequency reuse factors can be selected. Furthermore, FD-ICIC strategies also well adapt with Carrier Aggregation (CA) techniques, which have been introduced starting from LTE-A and enable an improved flexibility in the spectrum management.

6.2.2 Distributed FD-ICIC and DSA solutions

The setup of high-capacity and low-latency backhaul infrastructure is a major challenge in indoor environments. In this sense, centralized schemes for the network

management are expected to face several limitations in 5G networks. Distributed approaches have instead minimal backhaul communication requirements and thus constitute an attractive solution. In respect to fixed frequency reuse schemes, distributed FD-ICIC algorithms can cope with variable interference scenarios in the network by enabling the APs to dynamically adjust their spectrum allocation. In this sense, the concept of distributed FD-ICIC shares many of the objectives and assumptions with DSA.

In [68] a comprehensive overview of main categories of DSA approaches is given, highlighting fundamental differences from the regulatory and technology perspectives. An adapted version of the graphical summary proposed in [68] is provided in Figure 6.1. In the context of local-area small cells deployments, FD-ICIC schemes aim at enabling the cooperation between independent cells, where equal rights to the spectrum access are granted (e.g. between APs owned by a single operator, or multiple-operator APs operating in shared bandwidth allocations). Solutions discussed in this chapter can be then considered part of the DSA family for “*sharing among equals*”. This category differentiates, for example, from the Primary/Secondary type of access where different priorities for the utilization of the spectrum are set. A distinction can be further made in relation to the type of interaction existing between the network nodes: if the process of resource allocation is the result solely of common decision-making policies with no data exchange it can be described as “*implicit coordination*”, on the other hand, if direct information exchange between the peers is instead foreseen (i.e. assuming for example the presence of dedicated communication channels) “*explicit coordination*” occurs. ”It is generally known that information exchange improves the decision making process at the nodes, and therefore leads to higher throughput compared to schemes with implicit coordination. Implicit coordination, however, reduces the system complexity.

6.3 The Autonomous Component Carrier Selection algorithm

A specific FD-ICIC solution named Autonomous Component Carrier Selection (ACCS) has been selected as first target of the experimentation in this thesis [72]. ACCS is a DSA algorithm which has been originally conceived for interference mitigation purposes in LTE-A femtocell networks. The interest for ACCS in this thesis relies into its simple but effective decision-making process, which enables multiple APs in a randomly deployed network (also named enhanced NodeB (eNB)s following the 3GPP terminology) to dynamically adjust their spectrum occupation upon minimal information exchange.

The main concept behind the execution of ACCS is that the optimal sharing of the

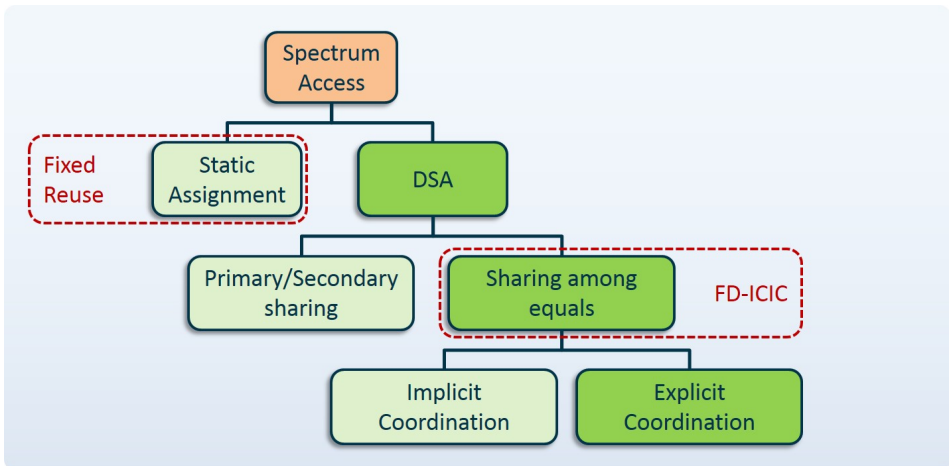

Fig. 6.1: Contextualization of the considered FD-ICIC mechanisms in this thesis among the different types of spectrum access approaches discussed in [68].

resources in a network is achieved as a trade-off between the traffic request in the cells and the principle that no excessive interference should be caused to closely-coupled neighbors. **ACCS** assumes that the available transmission bandwidth can be divided in a number of finite resources (e.g. **CCs** in **LTE-A** terminology) and their allocation is evaluated independently at each **eNB** on a periodical basis. The decision-making process mainly relies on **PHY**-layer interference estimations – generated locally at the **eNBs** as well as collected from the users – and on the exchange of explicit information about the spectrum occupation by competing cells. The information exchange between the **eNBs** requires minimum backhaul capabilities or the presence of an over-the-air control channel [73] in the network.

The **ACCS** execution can be summarized in two main procedures:

- The selection of a Base Component Carrier (**BCC**) which is intended to be the main communication carrier between the **eNB** and the **UEs**.
- The selection of Supplementary Component Carrier (**SCC**)s which provide additional channel capacity in order to satisfy the traffic request from the users.

At least one **BCC** must be selected by each **eNB** during the startup phase. The selection of **BCCs** is made as such that the allocation of overlapping **BCCs** between neighboring cells is discouraged —the purpose is to minimize the interference on the **BCC** thus guaranteeing a robust connection between the **eNB** and its **UEs**. The **BCC** selection process at the **eNB** mainly relies on two type of input information:

path loss estimations (i.e. obtained on the base of local **RSRP** measurements) in respect to other **eNBs** in the network —providing information about their “proximity”, in a radio sense— and the updated information about the resource allocation of active cells in the network (collected from the inter-**eNB** control channel [73]).

The **SCCs** allocation procedure aims instead at providing additional capacity, when requested, by activating supplementary spectrum resources. At network-level, the allocation of **SCCs** is conditioned to the fact that two cells sharing the same spectrum resources should not degrade their performance beyond a certain level, expressed in terms of Carrier to Interference (**C/I**) ratio. In this way, the algorithm aims at ensuring a fair resource allocation, limiting possible greedy behaviors. In mathematical terms, in order the CC_n to be considered for an **SCC** allocation, none of the following differences, in respect to cells already active in CC_n , must be found negative(from [74]):

$$Diff_{1-DL}(CC_n) = (C/I)_{incoming} - (C/I)_{SCC} \quad [\text{dB}] \quad (6.1)$$

$$Diff_{2-DL}(CC_n) = (C/I)_{outgoing} - (C/I)_{xCC} \quad [\text{dB}] \quad (6.2)$$

$$Diff_{3-UL}(CC_n) = (C/I)_{incoming} - (C/I)_{SCC} \quad [\text{dB}] \quad (6.3)$$

$$Diff_{4-UL}(CC_n) = (C/I)_{outgoing} - (C/I)_{xCC} \quad [\text{dB}] \quad (6.4)$$

With *incoming* it is intended the conditional **C/I** power ratio experienced by users in the local cell, if the allocation would succeed. Similarly, *outgoing* refers to the **C/I** experienced by users in the competing cell. $(C/I)_{xCC}$ represent the thresholds employed for the decision-making. Different values are typically defined depending whether the resource sharing is done in respect to a **BCC** or **SCCs**. Since the **BCC** is the main communication link with the users, stricter threshold values are typically applied in comparison to the **SCC**.

The activation of **SCCs** is conditioned to the traffic demands and the **SCCs** can be de-allocated in case of ceased request or unsatisfactory channel quality. Updated **C/I** information is typically shared between multiple nodes in the network, under the form of a Background Interference Matrix (**BIM**) [75]. All **ACCS** operations, as well as the control data exchange, execute on a regular time-frame basis. The **BCC** and **SCC** selection typically occurs at multiples of the **BIM** frame exchange. The time framing is supposed to be rather slow (e.g. from few hundreds of milliseconds up to several seconds) compared to baseline **RRM** techniques (e.g., time/frequency domain packet scheduling). Further information about the **ACCS** can be found in [74], [76].

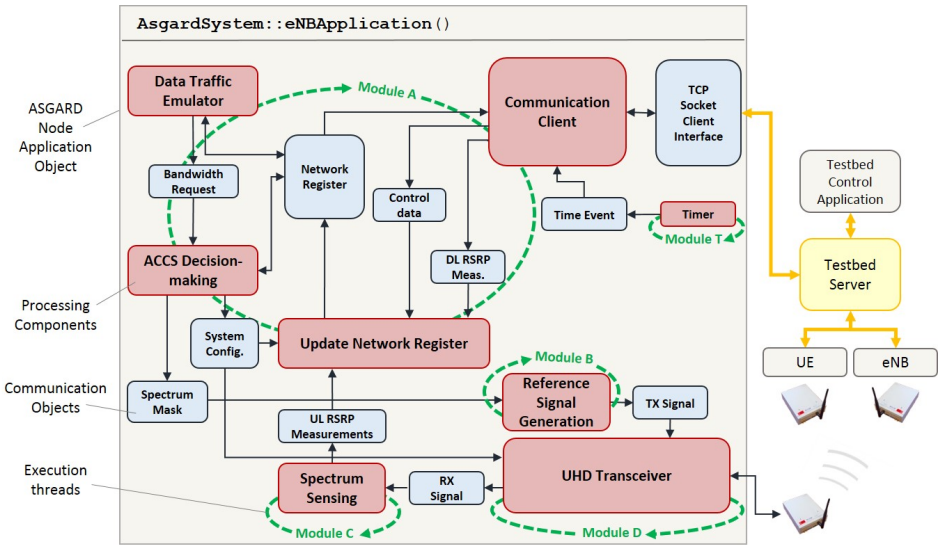

Fig. 6.2: eNB architecture in the ACCS testbed. The implemented elements with the ASgard building components are highlighted.

6.4 Realization of a testbed for ACCS

A testbed has been developed for the experimental analysis of **ACCS** —enabling the full algorithm execution in real-time. The testbed aims at supporting the execution of two types of nodes, essentially replicating the roles of **eNBs** and **UEs** in a cellular network deployment. The role of the **eNB** in the testbed is to trigger the execution of the **ACCS** allocation procedures thus enabling the measurement of performance **KPIs** such as the **SINR** and the throughput per cell. The **eNB** is responsible for the allocation of spectrum resources according to the traffic demands in the cell and the **ACCS** policies. The **UEs** are mainly intended as measuring terminals, providing feedback to the **eNB** for managing the resource allocation process.

In Figure 6.2 a scheme of the realized **eNB** software architecture is provided. The hardware configuration —common to all nodes— is similar to the one adopted for the channel sounder execution mode (described in Section 4.5.4) thus relying on the Ettus **USRP** N200 motherboards, the **XCVR2450 RF** daughterboards, and host computers running the ASgard software platform. The main design assumptions of the **ACCS** testbed is that the control and feedback plane (i.e. the information exchange among the **eNBs**, as well as the measurement reporting from the **UEs**) is foreseen to run over a backhaul network, e.g. Ethernet or WiFi. The purpose of the **PHY** transceiver is therefore only to support the multi-**CC** measurement of

the **RSRP** from multiple nodes. The **UHD Transceiver** interfaces with the **USRP** hardware through an Ethernet connection and exploits the **UHD** drivers. The **UHD Transceiver** manages the streaming of samples to and from the hardware as well as the reconfiguration of **RF** parameters (e.g. TX, RX gain) and the carrier frequency. In order to discriminate between multiple transmitting nodes, a configuration with orthogonal pilot tones—in the context of an **OFDM**-like system—has been devised. Each transmitting **eNB** is assigned a pattern over multiple subcarriers (multiple patterns are interleaved in frequency) which is repeated across all **CCs** defined within the system bandwidth. Typically an **IFFT/FFT** with 1024 bins is employed, offering sufficient subcarrier granularity (i.e. a trade-off between the number of **eNBs**, the number of subcarrier per pattern, considering the phase noise, details in Section 6.5.2) for the definition of 4 **CCs**. The received time samples are collected into a buffer and streamed to the **Spectrum Sensing** component which performs **FFT** operations and produces **RSRP** estimates per **CC**. All **RSRP** measurements are periodically collected by the **Update Network Register** which updates the *Network Register* data structure, where all information related to active **eNBs** and users are stored in an organized manner and made available to other elements in the system architecture. A **Data Traffic Emulator** has been implemented in order to support multiple data traffic models which trigger the resource request at the **eNB**. The traffic model generates a request in terms of **CCs**, which is given in input to the core element of the **ACCS/eNB** architecture, namely the **ACCS Decision Making**. The **ACCS Decision Making** is the Component actually implementing all the **ACCS** algorithm routines (i.e. the **BCC** and **SCC** selection procedure); in this sense, other elements in the architecture can be seen as supporting functionalities for its execution.

Flow charts of the actual implementation of the algorithm procedures in the testbed are provided in Figures 6.3 and 6.4 (the content of the figures has been adapted from the work presented in the work package 5 of the FP7 project SAMURAI [77]). **ACCS** procedures are executed on a time-frame basis corresponding to the **ACCS** frame and sub-frames (multiple sub-frames are contained within a single frame). The initial **BCC** selection procedure (Figure 6.3) occurs at the **eNB** bootstrap and relies on the periodical analysis of **RSRP** measurements which are collected into an organized data structure named Radio Resources Allocation Table (**RRAT**) [75]. Multiple timers, typically multiples of the **ACCS** sub-frame, are employed in the decision-making process, in order to be the final selection to be robust in respect to sudden input variations in time. The **SCC** selection process is instead a much more complex procedure which is continuously repeated in runtime. The flow chart depicted in Figure 6.4 relates to the management of the **SCCs** allocation—after a first **SCC** has been already allocated by the system. At every **ACCS** frame the interference conditions in the network, as well as the data traffic request by the users, are periodically evaluated and the **SCC** allocation is updated (i.e. *SCC management*).

The **ACCS Decision Making** Component generates then several outputs:

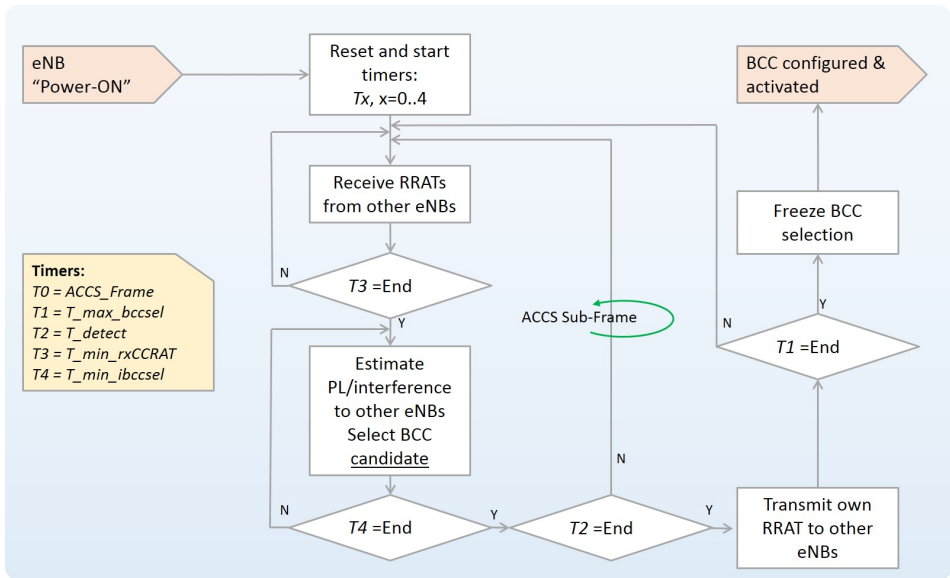

Fig. 6.3: Selection procedure of the initial BCC in ACCS as implemented in the testbed.

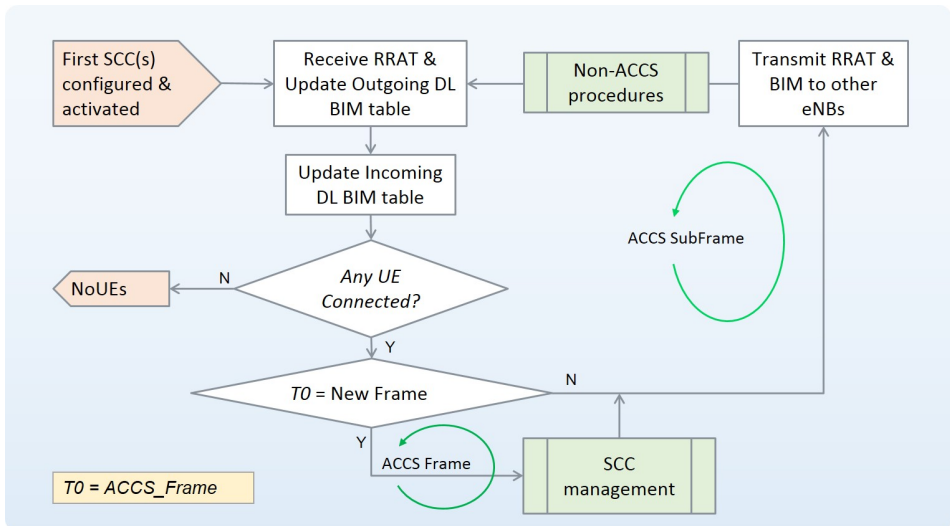

Fig. 6.4: Detail of the SCC management procedures, as implemented in the ACCS testbed

- an updated BIM information with the incoming C/I estimates
- a spectrum allocation mask, in terms of CCs to be occupied
- the updated control data signaling the current spectrum allocation

- an update about the **ACCS** framing status —interpreted by the **UHD** transceiver as trigger for TX/RX operations.

The updated control data (e.g. the **BIM**) is shared with the other nodes in the testbed through the control channel. The **Communication Client** Component takes care of accessing the control channel by interfacing with the testbed backhaul infrastructure through a **TCP**-based socket connection. The **Communication Client** forwards the control data to the **Testbed Server** as well as receives incoming data from the other **eNBs** and affiliated **UEs**.

According to the **ASGARD** platform design, multiple Modules are employed for managing the execution of the previously described system Components. Performance-sensitive components (i.e. those involved in the transmission and reception of the time samples) are allocated on independent threads of execution, allowing to better exploit the capabilities of multi-core processors. Less computational demanding operations, or tasks with coherent temporization requirements (i.e. the decision-making, register update, traffic emulation and transmission/reception of synchronized data) are aggregated on shared Modules, in order to limit the overall overhead in terms of multiple threads of execution.

The architecture of the **UE** is in large part identical to the **eNB**. The only difference is that all components related to the decision-making and signal generation have been removed since the only task performed by the **UE** is the measurement of **RSRP** in respect to the transmitting **eNBs**.

The general overview of the **ACCS** testbed architecture is given in Figure 6.5. The backhaul infrastructure provides connection among all the nodes and means for the remote control of the nodes and data collection. The control channel is emulated by a centralized unit in the testbed server which routes the control data among the registered **eNBs**. The feedback channel connecting the **UEs** to the affiliated **eNBs** is also emulated at the testbed server, and handles the reporting of the **DL RSRP** measurements. From a testbed management perspective, the **UE** logical affiliation to an **eNB** is transparent to the Feedback Channel Emulator, thus enabling the runtime reconfiguration at the nodes of the **UE** cell subscription. The overall synchronization of the data exchange is obtained by relying on the **NTP** service available at the host computers. One of the testbed nodes can also act as **NTP** time reference in case the testbed has no access to the Internet.

The purpose of the experimental trials with the **ACCS** testbed is to verify the algorithm capabilities of interference mitigation, in the context of practical deployment scenarios. In addition to the typical objectives of **RRM**-level solutions (e.g. establishing an optimal compromise between the signal coverage, Quality of Service (**QoS**) and overall cell throughput) distributed **FD-ICIC** schemes are also evaluated for their capabilities of providing reliable performance in a wide range of

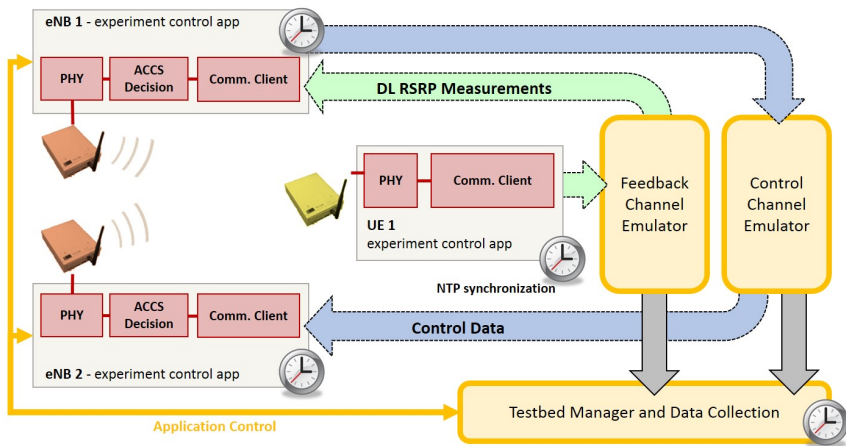

Fig. 6.5: Architecture and logic data flows in the ACCS testbed.

unplanned deployment conditions. The purpose of the ACCS testbed is therefore to enable the analysis of relevant metrics in this sense, e.g. the cell throughput gain in poor SINR conditions, the average cell throughput and the peak performance.

6.5 Live trials with ACCS

In a real-world setup, the system performance is influenced by a number of factors which include the actual network topology given by the nodes deployment, as well as time-varying phenomena given by dynamic propagation scenarios. The goal of the live execution trials with ACCS is to focus on the runtime network performance, thus the algorithm long-term reliability and robustness to dynamic operating conditions. In particular, three different type of experimental trials have been designed for the initial concept evaluation —tackling the problems of CCs cardinality, UE positioning in the cells and impact of human presence. The experimental activities described in this section have been included in the publication [13].

6.5.1 Testbed deployment

All the experiments considered in this section have been carried out at the office premises of Aalborg University in the NJV12 building (Figure 5.1.a). The environment is characterized by several rooms on the same building floor, arranged in

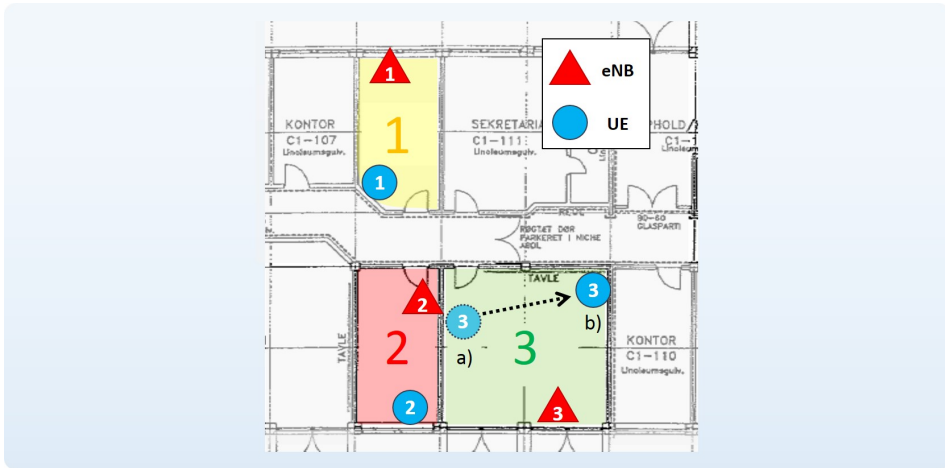

Fig. 6.6: Testbed Network Deployment across office rooms. Two positions a) and b) are considered in the experiments for the UE 3.

a double stripe fashion with a corridor in the middle. The experiments consider the deployment of 3 network cells across neighboring office rooms. The specific topology of the testbed nodes is depicted in Figure 6.6. 6 nodes have been utilized in total: 1 eNB and 1 UE are deployed for each cell. The objective pursued with such deployment is the definition of a clear inter-cell interference scenario: $cell_1$ is more spatially isolated, being on one side of the corridor, while $cell_2$ and $cell_3$ are placed in contiguous rooms thus intuitively being interference-coupled. Furthermore, two different configurations have been considered for the UE in $cell_3$: in position a) the eNB_2 is placed very close to the UE_3 , thus generating maximum interference. In Position b) instead, the opposite effect is obtained by increasing the distance between the two nodes. Despite employing a limited number of nodes, the considered deployment is of interest because it provides diversified interference coupling conditions across the network, which are challenging for $ACCS$.

6.5.2 Testbed configuration and trials execution

The three live execution trials with $ACCS$ have different characteristics: Experiment 1 aims at generally verifying the feasibility of the concept as well as providing a baseline benchmark for the system performance in static environment conditions. The impact of a variable number of system CCs is a major objective in this experimental campaign. Experiment 2 aims instead at analyzing the impact of intra-cell topology modifications (e.g. the movement the users) over the overall resource management process, thus providing an insight of the algorithm sensitivity to such

events. Experiment 3 investigates the capability of the decision-making process to cope with interference variations given by a dynamic propagation environment.

All trials share a number of common configuration parameters, summarized in Table 6.1. In order to cope with the presence of multipath fading in static environment conditions, trials are repeated across 10 different carrier frequencies, ranging from 4.91 to 5.81 GHz, in experiments 1 and 2. Given the variability of channel fading in a dynamic propagation environment, only a single carrier frequency (i.e. 5.41 GHz) has been employed in experiment 3. The total transmission power for all the nodes is set to 0dBm. Similarly to the configuration adopted for the channel sounder testbed (Section 4.5.4) a sampling rate of 12.5 MS/s is employed, resulting in a band-pass of 12.5 MHz —the maximum bandwidth of the occupied signal is of 10 MHz —depending on the number of active CCs. The size of the I/FFT is 1024 bins, which at the selected sampling rate gives a minimum spacing of 180 kHz between adjacent pilots. This pilot spacing proved to be sufficient to avoid the power leakage between subcarriers, due to the USRP hardware phase noise. The periodicity of the algorithm iterations (i.e. the ACCS execution frame) is 400 ms while the UE measurements reporting period is set to 200 ms. In this setup a single antenna configuration is assumed. The utilized dipole antennas have an omni-directional radiation pattern. The considered traffic model is full-buffer: once the UE connects to the cell, the eNB attempts to allocate the maximum number possible of CCs. A critical parameter for ACCS are the C/I thresholds utilized for the BCC and SCCs selection (see Section 6.3 for details). The values selected for these thresholds have a key role in determining the ACCS capabilities of frequency reuse and thus overall network performance. In this work, values of 10 dB and 4 dB have been selected, following the settings utilized in prior literature works, e.g. [76].

The ACCS algorithm is executed on the testbed in real-time, thus generating time data traces of the eNBs control data and UEs RSRP measurements. These experimental results have been processed in order to extract network-wide statistics about downlink SINR experienced in the cells, and the corresponding estimated capacity which is obtained through Shannon mapping [29]. The SINR is first measured on the narrowband pilots, and then scaled to the effective emulated bandwidth of the used CC configuration. Bandwidth scaling is also applied to the Shannon mapping over capacity.

6.5.3 Static environment algorithm analysis

The goal of the first experiment (Experiment 1) is to provide a baseline indication of the network performance in a static environment scenario. In particular, the impact of a different CCs cardinality (i.e. the total available bandwidth can be divided in an arbitrary number of spectrum chunks, affecting the spectrum reuse

Table 6.1: Overview of configuration parameters utilized for the live execution experiments with the ACCS testbed.

Experiments	1	2	3
Environment characteristics	Static	Static	Dynamic
Deployment setup	a)	b)	a)
CCs configuration	2/3/4	4	4
System Carrier Frequency	Variable, from 4.91 to 5.81 GHz	Variable, from 4.91 to 5.81 GHz	5.41 GHz
Tx power per CC	0 dBm		
Channel configuration	2/3/4 CCs		
Signal Bandwidth	10 MHz		
Trasnceiver I/FFT size	1024 points		
Pilot tones spacing	180 KHz		
ACCS frame	400 ms		
ACCS Sub-frame Measurement re-reporting	200 ms		
Antenna configuration	SISO		
UE Traffic model	Full buffer		
Target C/I for BCC	10 dB		
Target C/I for SCC	4 dB		

capabilities of the network) is investigated. In order to meet the static environment assumption, all experiments runs have been executed during night hours. The experiment deployment considers the UE_3 to be placed in position *a*) according to Figure 6.6. Iterations with 2, 3 and 4 CCs have been performed. As a term of comparison, the ACCS performance is then compared with a standard Reuse 1 frequency allocation scheme where it is assumed all cells occupying the entire available bandwidth. A single run of the experiment consists in the following steps:

- eNBs are activated sequentially and a single BCC is selected per cell.
- UEs are activated sequentially within an interval of a few ACCS frames. One cell's SCCs are allocated as soon as the affiliated UE connects. The SCC allocation procedure is completed before another UEs is activated.

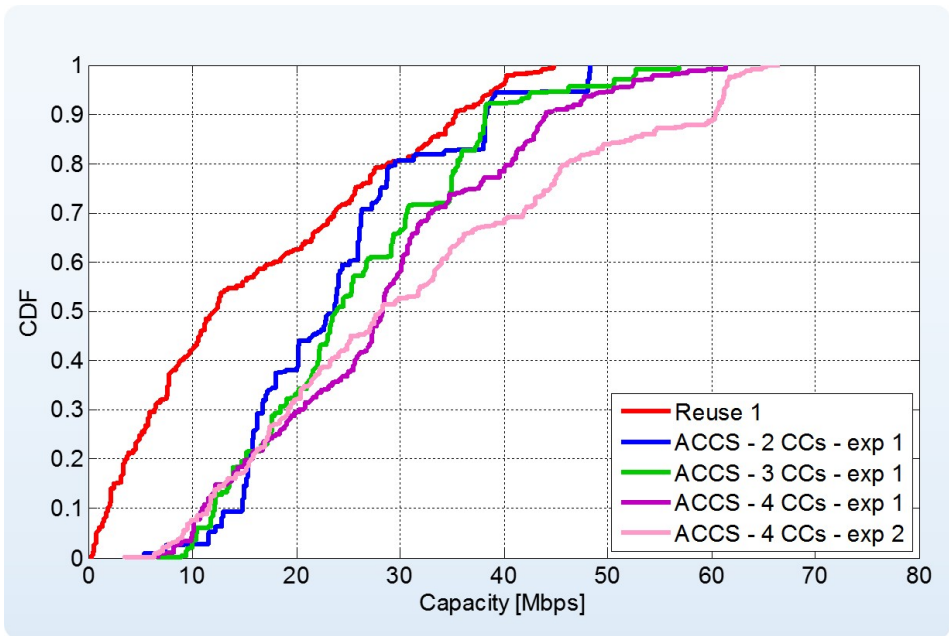

Fig. 6.7: Experiment 1: cells' capacity CDFs

The nodes activation sequence has a considerable impact on the final CC allocation across the cells, since in full buffer traffic model conditions the first cells to be activated tend to a greedy occupation of the spectrum. Allocated SCCs are not to be released unless the channel quality becomes unsatisfactory. This assumption leads therefore to an extremely competitive environment where the RRM algorithm is challenged to provide minimum service performance to the users.

In order to cover all the possible combinations activation sequences for both the UEs and eNBs in a 3-cells scenario, 36 experiment runs are needed. Considering the multiple carrier frequencies employed for the averaging of the multipath-fading effect, the amount of experiment runs for each CC configuration is therefore 360. In total, 1080 live execution runs have been performed for the evaluation of 3 different CC configurations.

The obtained results in terms of downlink Shannon channel capacity are presented in Figure 6.7. Every capacity sample in the CDFs corresponds to the value registered for a user at the end of the experimental run, when stable operating conditions have been achieved (i.e. averaging in time is performed from the moment when all nodes have been activated and all SCCs selection procedures have been completed). In general, it is expected that ACCS can deliver the largest throughput gains in situations where, due to high interference, users are suffering of low

SINR. In these cases, the benefit derived by the fractional spectrum reuse and interference orthogonalization is indeed typically higher. Such behavior is confirmed by the experiments and can be appreciated in Figure 6.7 by comparing the curves related to the frequency Reuse 1 scheme and ACCS (exp 1 only). Larger gains are experienced in the lower percentile of the CDF (corresponding to highly interfered users, mostly located in $cell_2$ and $cell_3$) while lower gains are instead achieved for the least interfered users (mostly corresponding to the spatially isolated $cell_1$). The obtained results show, moreover, that moving from Reuse 1 to a configuration with 2 CCs is sufficient to mitigate most of the interference, thus providing the major gain contribution. This behavior is somewhat expected in the considered deployment scenario, since only 2 cells ($cell_2$ and $cell_3$) are strongly interference-coupled while one ($cell_1$) is instead more isolated. Further increasing the CCs cardinality provides more flexibility in the spectrum management (i.e. best performing users may be able to exploit even larger bandwidth allocations with a higher CCs granularity), however only marginal gains are achieved in outage.

6.5.4 UE position impact

The performance achieved in the network is clearly dependent on the specific deployment configuration of the nodes. In experiment 1 the overall resource allocation is conditioned by the high interference-coupling between $cell_2$ and $cell_3$, which is mainly due to the positioning of eNB_2 and UE_3 . By modifying the conditions of this link we may expect different behaviors in the network. In order to verify the sensitivity of the ACCS performance to such changes in the deployment, a second experiment (experiment 2) has been designed. In comparison to the deployment adopted for experiment 1, UE_3 has been moved to the other side of $room_3$ (position b) in Figure 6.6), in order to maximize the pathloss with respect to eNB_2 .

The execution of experiment 2 follows the same procedure as experiment 1. A single channel configuration with 4 CCs has been considered in this case. Statistics about the CCs utilization, obtained from the experiments, have been summarized in Table 6.2 and Table 6.3. As for experiment 1, the reported values are related to the entire experimental session and are averaged over 360 runs. Data in the tables show that the variation in the level of interference experienced in $cell_3$ from experiment 1 to experiment 2 has a widespread impact on the amount of resources allocated in the entire network. In the first case, $cell_2$ and $cell_3$, being extremely interference-coupled, trigger a perfectly orthogonal allocation of their resources by ACCS (i.e. no shared resources in Table 6.2). In experiment 2 instead, the more isolated position of UE_3 diminishes the cell coupling thus enabling a better utilization of the spectrum by all the cells. Opportunities for frequency reuse among the cells are also increased, especially looking at $cell_1$ which is the most isolated according to the deployment scenario (please note that although $cell_1$ is

relatively isolated, a minimum amount of interference is still experienced from $cell_2$ and $cell_3$). Following the previous analysis, the results show an increase in cell capacity affecting the upper percentile of the CDF in Figure 6.7 (i.e. from 0.6 to 1, comparing exp 1 and exp 2 cases for 4CCs), which are indeed mostly related to the performance of the users in $cell_1$. Conversely, the lower percentile of the CDF is almost insensitive to the re-positioning of UE_3 , due to the unmodified—heavy—interference contribution of eNB_3 in respect of UE_2 .

Table 6.2: Experiment 1, overview of spectrum utilization in the cells.

Cell	Spectrum usage (4CCs=100%)	Shared spectrum resources (4CCs=100%)		
		Cell 1	Cell 2	Cell 3
1	84%	-	32%	20%
2	48%	32%	-	0%
3	48%	20%	0%	-

Table 6.3: Experiment 2, overview of spectrum utilization in the cells.

Cell	Spectrum usage (4CCs=100%)	Shared resources (4CCs=100%)		
		to Cell 1	to Cell 2	to Cell 3
1	95%	-	45%	53%
2	49%	45%	-	5%
3	54%	53%	5%	-

6.5.5 Dynamic environment algorithm analysis

The fast fading effect on the channel—due for example to the human presence in the environment—may cause rapid variations in the C/I and SINR which can negatively affect the decision-making process of RRM algorithms. The third experiment carried out with the testbed aims therefore at verifying the ACCS sensitivity to such phenomena. In particular, the suitability of fixed decision-making thresholds, for the BCC and SCCs selection, is of major interest in the analysis.

Experiment 3 utilizes the same deployment scenario as experiment 1. A configuration with 4 CCs is considered; the carrier frequency is set to 5.41 GHz. The analysis of performance metrics which are related the variation of spectrum power measurements, may vary according to the assumptions adopted for the measurements generation. In the employed testbed configuration each RSRP sample utilized for the C/I and SINR computation is the result of an averaging process conducted

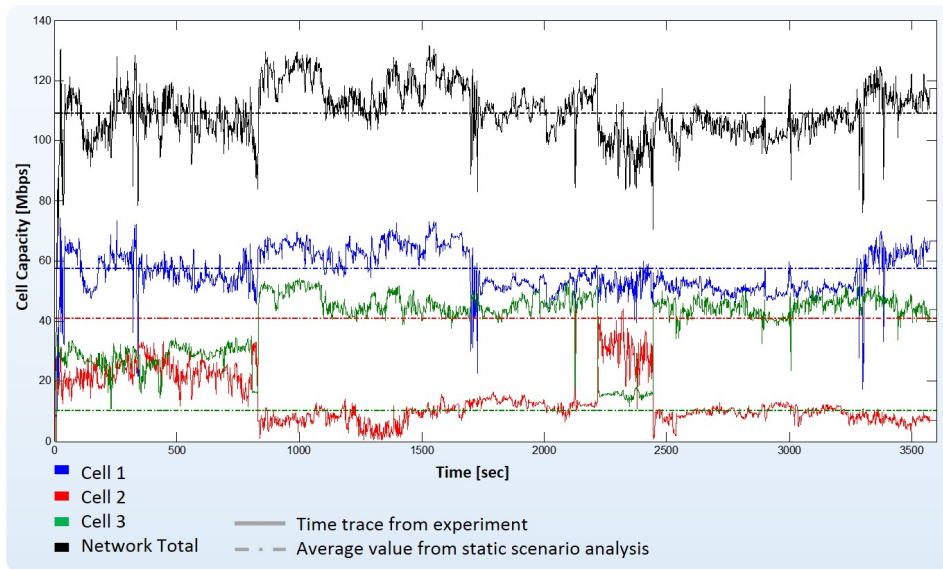

Fig. 6.8: Experiment 3: snapshot of downlink capacity variations in time during a 1 hour experimental run.

first, in the frequency domain (i.e. multiple power measurements averaged over the subcarriers utilized in the reference signal frequency pattern) and then in time (i.e. power measurements are averaged first within a single ACCS sub-frame interval —200ms— and then over multiple sub-frames —4 sub-frames).

In order to acquire results about realistic operating conditions, the experiment has been executed during working hours in the offices allowing human presence. The rooms employed in the deployment are characterized by different levels of human activity: $cell_1$ is on average less crowded than $cell_2$ and $cell_3$ (i.e. max 1 person is present in $room_1$, 3 persons in $room_2$ and 2 persons in $room_3$). The trial execution duration is of 1 hour (i.e. 3600 sec), during which nodes are activated, BCC selection procedure is completed and SCCs are turned off/on according to the variable interference conditions in the environment. User traffic model is assumed to be full-buffer, triggering a persistent request for maximum spectrum resources.

A time snapshot of the obtained downlink channel capacity results (in [Mbps]) from a 1 hour run, is depicted in Figure 6.8. The plot shows considerable fluctuations of the values in time, particularly related to $cell_2$ and $cell_3$ which basically share common spectrum resources and alternate their allocation according to the mutating channel conditions. $Cell_1$ shows instead a stable performance in time, thanks to its spatial isolation and low variability of conditions in $room_1$. The total network capacity (i.e. give by the instantaneous sum of individual cells) is also

rather stable in time, thus showing good capabilities by ACCS, of managing the overall resources in a network in a dynamic operating context.

Table 6.4: Experiment 3, Downlink Channel Shannon Capacity Statistics over 1 hour. Data is in Mbps.

Cell	\bar{X}	σ	Reference from experiment 1
1	56.3	7.3	57.6
2	13.7	8	41.1
3	39.5	10.4	10.4
Network Total	109.5	9.5	109.1

Performance results from the experiments are also summarized in Table 6.4. The table reports the values of downlink cell capacity averaged in time (\bar{X}) across multiple trials. Values are expressed per cell, in *Mbps*. Standard deviation of the results (σ) is also included. In general terms, the experiments confirms that the most interference-isolated cell (i.e. $cell_1$) achieves considerably higher channel capacity than $cell_2$ and $cell_3$ which are instead forced to share resources. However, if we compare these results with those obtained in static environment conditions in experiment 1 (assuming identical network topology), it is interesting to notice that the achieved channel capacity in $cell_2$ is exactly the opposite of the capacity of $cell_3$. This behavior is due to the concurrent impact of several factors:

- The aggressive SCC allocation scheme, which in case of full-buffer traffic model impedes the release of allocated resources unless poor SINR conditions are experienced.
- The strong interference coupling between $cell_2$ and $cell_3$.
- The variability of channel conditions.

While in static operating conditions a fragile equilibrium is achieved, favoring the allocation of resources by $cell_2$, in a dynamic context, the variability of the C/I and SINR may force $cell_2$ to back-off from the spectrum occupation, thus freeing resources for the competing neighbors (i.e. $cell_3$). In order to provide a visual understanding of this highly-competitive resource allocation scenario, a time snapshot of the measured C/I values by $cell_1$ during an experiment run is provided in Figure 6.9. The allocation of resources by ACCS is always conditioned by the level of the C/I values in comparison to the pre-defined BCC and SCC thresholds. From Figure 6.9 it is evident that while in a static environment the measured C/I is almost constant in time, the human activity introduces fluctuations which may impact the ACCS allocation.

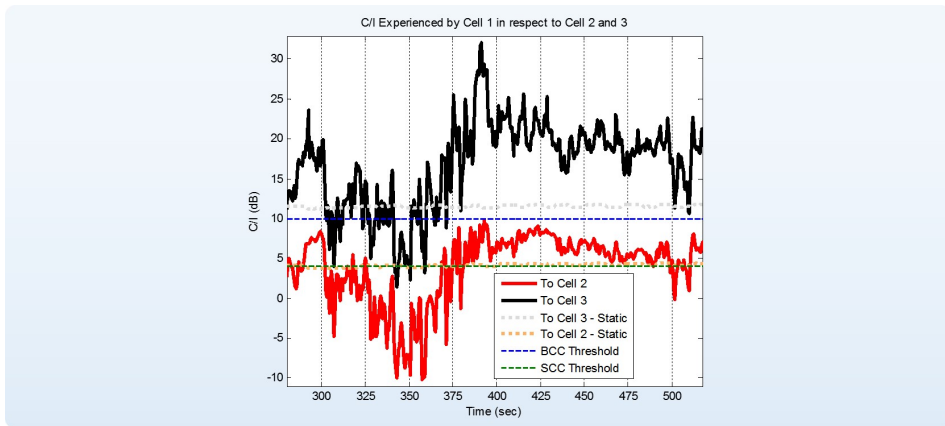

Fig. 6.9: Experiment 3: snapshot of C/I variations in time measured by Cell 1 in respect to Cell 2 and Cell 3. Values experienced in static scenario are also included as term of comparison.

The overall results in terms of C/I are reported in Table 6.5 (only values for $cell_1$ in respect of $cell_2$ and $cell_3$ have been here selected for simplicity). The obtained values are compared between the dynamic and static scenarios as well as in respect to the simulated values obtained considering a WINNER II A1 path loss model [65]. The results show a substantial mismatch between the values obtained in dynamic propagation environment and the static case, which instead are well aligned with simulations.

Table 6.5: Experiment 3: comparison between simulation and experimental results of cell 1 C/I in respect to cell 2 and cell. All values in the table are in dB.

[dB]	Exp. Dynamic Scenario		Exp. Static Scenario		Simulation	
	\bar{X}	σ	\bar{X}	σ	\bar{X}	σ
$(C/I)_{1/2}$	10.48	4.075	4.254	0.146	4	0
$(C/I)_{1/3}$	18.03	3.905	11.6	0.133	13	0

6.5.6 Discussion

The previously described experimental activities enabled the proof-of-concept of ACCS and contributed to demonstrate the feasibility of distributed RRM techniques as possible solutions to the inter-cell interference problem in local area wireless networks. Experimental trials targeted challenging scenarios for the resource allocation in a small network setup. Experiments in static propagation environment allowed first to verify the fundamental contribution of ACCS: the

obtained results, in terms of theoretical downlink channel capacity, show an overall performance gain in respect to a Reuse 1 resource allocation scheme. In particular, capacity improvements have been confirmed for users in poor SINR conditions as stated by prior literature studies [72]. Subsequently the experiments focused on the impact of the UE positioning on the overall resource allocation process: by modifying the interference conditions in one of the network cells, wider-scale effects may be generated, triggering a re-balancing of the allocated resources in the network. In the considered scenarios, ACCS proved to adapt well to different node topologies, ensuring consistent capacity gains to the worst 10% of the users, of about 500% in comparison to a frequency Reuse 1 scheme.

Experiments in a dynamic environment aimed at individuating critical areas for the algorithm reliability in runtime. Depending on the aggressiveness of the CCs allocation policies (i.e. currently the concept description does not provide clear indications — a detailed analysis of such issue is a priority for future developments of ACCS) C/I fluctuations in dynamic environments may trigger high capacity variations between the cells during time. In particular, the policies adopted for the release of the occupied resources (e.g. under which circumstances? how quickly to respond?) are critical for the algorithm performance (e.g. fairness). The problem is typically exacerbated in high data traffic conditions, while more relaxed traffic assumptions can considerably help in managing the allocation/de-allocation of resources.

C/I variations are in general complex to track for an RRM algorithm: a fast-tracking approach (i.e. an ACCS frame of few hundreds of milliseconds) enables to quickly respond to changes to the topology and channel propagation. On the other hand, considering the much faster variations of the traffic request as well as the overhead incurred in the increased control signaling, such type of approach may not be as beneficial. A dynamic management of the thresholds is instead desirable in ACCS, improving its effectiveness in dynamic scenarios. In this sense, cognitive processes featuring learning capabilities may provide a useful contribution. The implementation and experimental validation of cognitive decision-making solutions is one of the most interesting research areas, for future activities with the ACCS testbed

6.6 ACCS analysis with Hybrid Simulations

The previous experiments focused on runtime execution aspects of ACCS. This section aims at investigating the impact of the network deployment characteristics on ACCS, thus verifying the algorithm capabilities of adapting to multiple interference scenarios. By employing hybrid-simulations and the experimental data acquired with path loss measurement campaigns of Chapter 5, experiments pre-

sented here also aim at validating prior simulation-based studies([74] [78]) in indoor office/residential scenarios. The following discussion is derived from the work published in [12].

6.6.1 Analysis of fundamental configuration parameters

Multiple configuration parameters may affect the performance of distributed **FD-ICIC** schemes. As previously demonstrated in the live execution experiments, the cardinality of the **CCs** is one of the most critical of these. In order to extend the previous analysis to larger network deployments the impact of a variable number of **CCs** has been addressed also with hybrid-simulations.

The experimental path loss data from the NJV12 scenario (Figure 5.1.a) have been utilized as the basis for the performance analysis of multiple random network deployments in an office type of environment. A summary of the configuration parameters employed in the hybrid-simulations is provided in Table 6.6. 10 cells are considered with 1 **UE** per cell. The **UE** affiliation policy is **CSG**. A variable number of **CCs** are analyzed, from 1 (i.e. equivalent to a Reuse 1 allocation scheme) to 6. The total available bandwidth is set to 10MHz (i.e. compliant with the signal bandwidth utilized for acquiring the path loss measurements). The total Tx Power is assumed to be 24 dBm. The minimum **SINR** useful for having connectivity is set to -8dB. The **UE** traffic model is full buffer thus determining a highly-competitive operating scenario where all cells attempt at occupying the largest amount of resources possible. The obtained results have been collected in terms of downlink cell throughput (i.e. calculated with through mapping of the **SINR** through the modified Shannon formula in [29]) —a single throughput sample is the result of the average performed over 100ms of simulation time.

Table 6.6: Configuration parameters adopted in hybrid-simulations

Cells/Number of UEs	10/1 UE per cell
User affiliation	CSG
Number of CCs	Variable (1-6)
Total Bandwidth	10 MHz
Tx Power	24dBm
Minimum SINR for service	-8dB
Power per CC	Variable spectral power density according to CCs allocation
Traffic model	Full buffer
Total simulation time per snapshot	100 sec

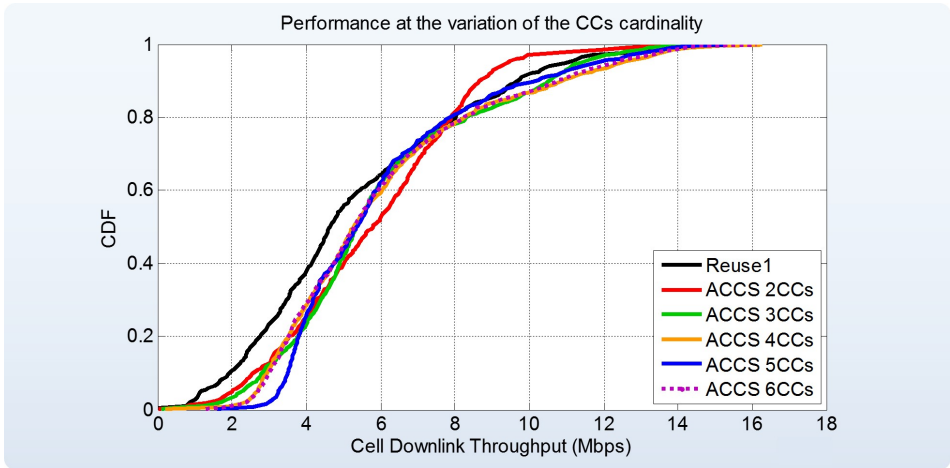

Fig. 6.10: ACCS performance in relation to the number of CCs utilized

The obtained results from the hybrid simulations are reported in Figure 6.10: multiple CDFs have been included, one for each CCs configuration considered. The results show a general gain provided by ACCS (i.e. comparing in respect to a frequency Reuse 1 scheme —black curve), particularly to outage users (i.e. the lower 5-th percentile of the CDFs). According to prior literature studies in large office/residential scenarios [68], a frequency reuse scheme greater than 5 is sub-optimal even in dense deployment conditions (i.e. due to topology characteristics of the network in such type of scenarios). The obtained results with the NJV12 scenario confirm these findings, showing a degraded performance by the ACCS configuration with 6CCs comparing to 5CCs. As it concerns the upper part of the CDFs (i.e. users in high SINR conditions due to low interference), no significant benefits are achieved beyond a configuration with 2 CCs. Two motivations can be mainly identified for such behavior: firstly, in low interference conditions the algorithms allows the exploitation of large bandwidth allocations regardless of the specific number of CCs in the system configuration. Secondly, an high-SINR user typically suffers of a limited amount of significant interferers, thus a greater fractioning of the spectrum brings negligible benefits.

A second aspect which has been targeted by the hybrid-simulation analysis is the tuning of the ACCS BCC and SCC decision-making thresholds. Different values for the thresholds determine the level of frequency reuse allowed by ACCS in the network. Whenever a cell wants to allocate a BCC or an SCC, the potential C/I in respect to neighboring cells occupying the same resource is evaluated. If the potential C/I is lower than the threshold – either for the local node or the neighbors – the CC is not allocated. In general terms, restrictive thresholds hinder the sharing of resources between cells thus minimizing the interference; lower thresh-

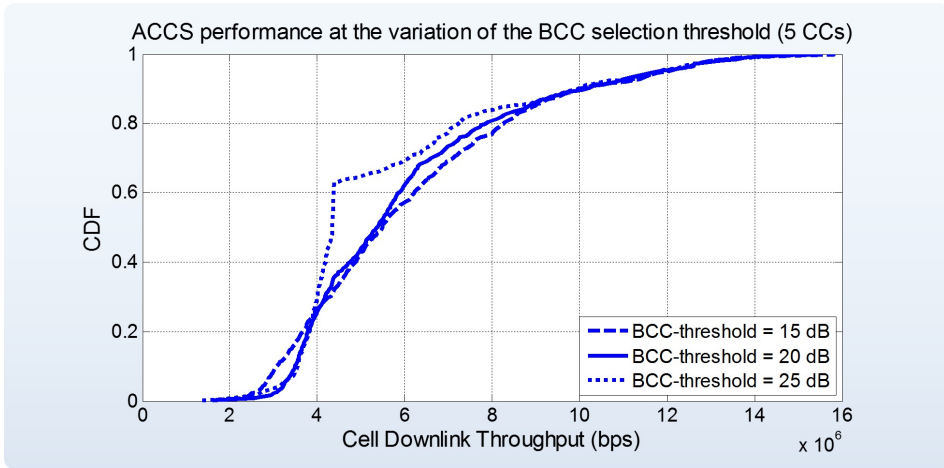

Fig. 6.11: Evaluation of the ACCS BCC selection threshold

olds enable instead wider spectrum allocations. The values set for the thresholds are typically fixed since they should be common to all the nodes in the network. Optimal values may vary according to the deployment scenario; according to the literature, the thresholds are empirically defined. In order to highlight the ACCS performance sensitivity to the threshold parameters a series of studies have been conducted in the NJV12 office scenario. In particular, multiple levels for the BCC threshold have been analyzed, i.e. 15, 20 and 25 dB. As a reference, literature studies in the 3GPP dual stripe scenario model [78] utilized a BCC threshold of 15 dB. Obtained results have been reported in Figure 6.11. The CDFs show the network performance in terms of downlink throughput in the cells, given by the execution of ACCS with different thresholds. As expected, a lower threshold eases the sharing of resources thus it penalizes users in high-interference conditions (i.e. a lower orthogonalization of resources is produced). Conversely, low thresholds also allow to achieve greater capacity in high SINR situations, thanks to the possibility of allocating a greater number of resources, more easily. Increasing the value of the thresholds leads to an opposite trend: the sharing CCs becomes more difficult thus a higher frequency reuse is enforced in the network. In particular, the curve related to the 25dB threshold shows the typical “saturation” effect, which affects those users that, due to more the restrictive spectrum sharing policy, are limited by the SINR achieved on the already occupied resources. In the considered deployment scenario, an intermediate threshold of 20dB seems to provide an optimal trade-off between the outage users protection and the average network performance.

6.6.2 Validation of simulation-based studies

Hybrid-simulations can provide a more realistic performance insight, comparing to traditional simulations, because accurate information about the real-world links is directly utilized to simulate multiple network deployments. In this sense, the results previously discussed for the NJV12 scenario, can be utilized as a term of comparison for validating prior studies obtained with reference scenario models. In this section we will refer, in particular, to the analysis presented in [78], which considers a large deployment of indoor femtocells in a 3GPP dual stripe scenario. The work done in [78] investigates the ACCS performance in different operating conditions. The work presented in this section has a focus limited to the downlink network performance and full buffer type of traffic. The objective of the analysis is to relate the results obtained in the NJV12 scenario with two specific DRP (i.e. the probability that an apartment/room in the scenario contains an active cell) in the dual stripe scenario: 20% and 80%. A 20% DRP corresponds to a sparse deployment of cells in the environment, thus expecting lower interference, while 80% DRP represents a much denser scenario.

In order to compare the results obtained with an experimental scenario with a simulation model, it is first important to understand under which circumstances these two can be considered similar. In particular, comparing the starting interference conditions in the network, for a universal frequency reuse, can provide useful indications whether an interference mitigation scheme can be expected to deliver an equal performance. In [78] as well as in [71], the *G(eometry)-factor* metric is specifically utilized for the interference analysis of different scenario deployments. The G-Factor consists of *the ratio between the total wideband signal power and the interference plus noise at the receiver (UE) side*, prior detection.

Figure 6.12 shows the G-Factor CDFs obtained considering 100 random network deployments of cells in the NJV12 and 3GPP Dual stripe scenarios. 10 active cells are considered for the NJV12 scenario. 20% DRP gives an average of 24 active cells, while 80% DRP gives an average of 96 out of a total of 120 cells. The NJV12 scenario shows a G-Factor CDF with a rather narrow range (i.e. about 20dB between the worst and top performing users); this characteristic is due to the spatially compact deployment of cells across the rooms of the NJV12 building. The 3GPP Dual Stripe scenario is instead much larger thus generating a wider range of G-Factor values for users in different interference conditions. By looking at the curves, the outage network performance (5-th percentile of the CDF) in the NJV12 scenario closely match the values achieved in the 20% DRP Dual Stripe scenario. This suggests that network deployments in these two scenarios determine comparable interference conditions for their worst performing users. Conversely, the performance of the best users (95-th percentile of the CDF, i.e. only 5% of the users achieves a better performance) suggests that the interference scenario in the NJV12 configuration is more penalizing than in the Dual Stripe. This effect can be

intuitively explained with the much larger dimensions of the Dual Stripe scenarios, which provide greater opportunities for the deployment of spatially isolated cells. In this case, G-Factor statistics comparable to the NJV12 scenarios could be generated by assuming a larger amount of APs to be deployed, corresponding to higher DRP. Consequently, when evaluating the possible gains derived by the utilization of an interference mitigation solution, we expect that the results in the NJV12 scenario outage are aligned with the in the Dual Stripe 20% DRP outage. On the other hand, results for the average and best users should better compare to the Dual Stripe 80% DRP —or even higher DRP.

In order to confirm these insights with ACCS, results from the previously described hybrid simulations in the NJV12 scenarios have been compared to the results published in [78] and are summarized in Table 6.7. The reported values in the table relate to the downlink cell capacity and are normalized by the maximum theoretical capacity of the system (the capacity which would be achieved in total absence of interference). The comparison between the scenarios is proposed for Reuse 1, ACCS and also a non-parametric version of the algorithm, named Generalized-ACCS (G-ACCS) [78]. The table further differentiates between the performance in outage, average and peak (i.e. the best performing users). Compliant simulation parameters (e.g. CC cardinality, transmission power and receiver characteristics) have been utilized in both hybrid simulations and the literature.

As previously discussed, the outage performance of all resource allocation schemes in the NJV12 scenario shows comparable values with the 20% DRP dual stripe case. The average cell throughput instead is well aligned with the 80% DRP dual

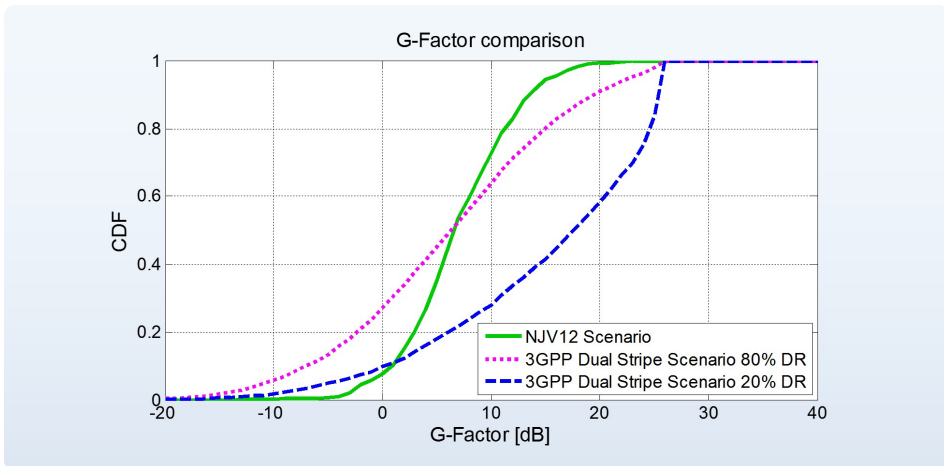

Fig. 6.12: Comparison of G-Factor distributions between random network deployments in the NJV12 experimental scenario and the 3GPP Dual Stripe with 20% and 80% deployment ratios.

Table 6.7: Normalized downlink cell throughput in the network.

Scheme	Scenario	Outage	Avg	Peak
Reuse1	NJV12	6.6%	29.7%	60.8%
	Dual Stripe 20% DR*	5%	60%	100%
	Dual Stripe 80% DR*	0.9%	21%	64%
ACCS	NJV12	18%	33.3%	65.8%
	Dual Stripe 20% DR*	19%	66%	100%
	Dual Stripe 80% DR*	12%	30%	59%
G-ACCS	NJV12	15.1%	33.3%	79.4%
	Dual Stripe 20% DR*	17%	70%	100%
	Dual Stripe 80% DR*	6%	32%	72%

*results related to the 3GPP Dual Stripe scenarios are reported from [78]

stripe. The peak performance results, i.e. the 95%-tile of the network users, are not far from the 80% DRP values: the lower capacity reached in both the Reuse 1 and ACCS cases, however, suggest that the best users in the NJV12 scenario are suffering of an even higher level of interference (comparable to the interference which would be achieved in a Dual Stripe scenario with DRP higher than 80 %). The performance gain, between ACCS and a Reuse 1, obtained with the 3GPP Dual Stripe simulation models proved to be generally in line with the results obtained in the experimental scenario. Furthermore, in [78] it is also reported that the G-ACCS enables to achieve greater capacity than ACCS for the best users. The results of Table 6.7 also confirm this performance trend.

6.6.3 Performance analysis in open-area scenario

In the previous analysis it has been highlighted how the performance gains of FD-ICIC solutions may vary according to the network deployment assumptions. Topology features are very dependent on the geometry and propagation characteristics of the deployment environment. In an office/residential scenario, for example, with CSG user affiliation to APs located in the same room/apartments, the presence of walls helps in defining high SINR regions in which the users are located. Moreover, the number of strong interferers is often limited to the number of contiguous rooms/apartments physically surrounding the serving cell. In other contexts, such as open-area scenarios where LOS links typically occur between the user and the interfering cells, the interference characteristics and thus the mitigation requirements may be considerably different. Following this assumption, in this section we extend the performance analysis of ACCS, also to an open-area/mall

Table 6.8: Deployment configuration considered in the NJV14 open-area scenario

Deployment	Characteristics
a) APs in the hall (low-density)	4 APs deployed along the walls of the main hall, 4 UEs randomly deployed, OSG affiliation
b) APs in the hall	6 APs deployed along the walls of the main hall, 12 UEs randomly deployed, OSG affiliation
c) APs in the hall (high-density)	12 APs deployed along the walls of the main hall, 12 UEs randomly deployed, OSG affiliation
d) APs in the rooms	6 rooms, 1 AP per room, 12 UE randomly deployed, OSG affiliation

type scenario. The objective is to verify the algorithm capabilities of managing the resource allocation in a scenario with fundamentally different topology characteristics.

The evaluation process relies once again on hybrid-simulations. The experimental data collected in the NJV14 building (Figure 6.13) have been utilized for the analysis of multiple random network deployments, in a practical case. Multiple deployment configurations with different characteristics have been evaluated in the NJV14 scenario. In particular, variable AP density and AP locations have been analyzed. A brief description of the selected deployment cases is reported in Table 6.8.

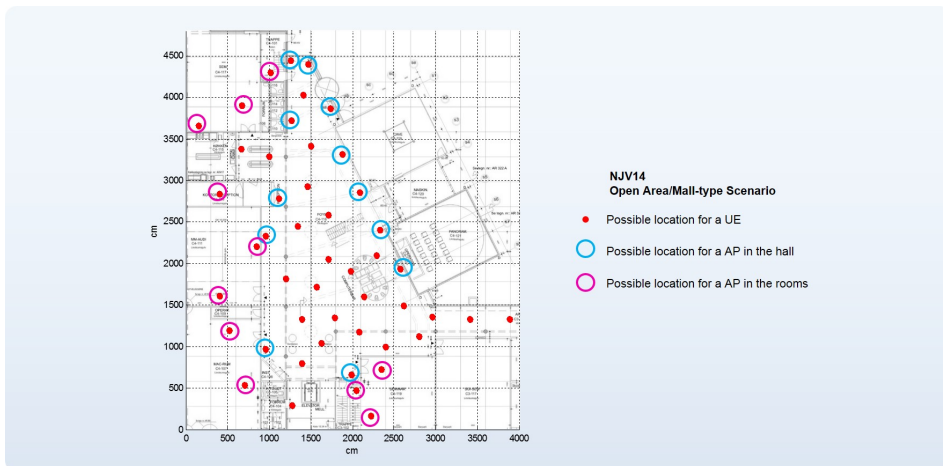

Fig. 6.13: NJV14 open-area/mall type scenario. Overview of node locations utilized in hybrid-simulations

Figure 6.13 depicts the relevant node positions considered in the analysis. The deployments with *APs in the hall*, assume a variable number of APs to be deployed along the walls of the central hall in the NJV14 building. A variable number of UEs (i.e. from 4 to 12) are also deployed, randomly located across the available positions in the space. A fourth case with *APs in the rooms*, assumes the APs to be deployed across the rooms surrounding the hall. Maximum 1 AP is deployed per room. The main difference between the two cases is that in cases *a), b), c)* the majority of links are in LOS; on the contrary, in case *d)* most of AP-to-UE links are in NLOS. In all 4 deployment scenarios the UE affiliation policy is OSG. It is assumed that multiple UEs can then connect to the same AP thus sharing intra-cell resources (intra-cell resources are equally split among the UEs in a round robin fashion). APs with no connected UEs are considered inactive. The analysis focuses only on the downlink performance. All settings utilized for the hybrid-simulations are consistent with those previously reported in Table 6.6.

Results in terms of normalized cell throughput are reported in Table 6.9. ACCS results for multiple CC configurations have been generated. *Reuse 1* frequency scheme has been included as baseline reference for comparison. Also in this case, the *outage* values relate to the performance of the worst 5% of the users, average refers to the average cell throughput, while the peak performance considers the throughput achieved by the 95-th percentile of the users.

Comparing to the results previously obtained in office scenario (i.e. 6.7, NJV12 and 3GPP Dual Stripe) results in Table 6.9 show generally a worse network performance for all frequency reuse schemes considered. As expected this can be explained with the extremely high interference in the environment given by the absence of spatial separation between the cells. Particularly critical is the case of *Reuse 1* which appears incapable of providing connectivity to outage users in any of the considered cases (the minimum SINR for having connectivity is set to -8dB). In relation to ACCS, some of the performance trends seen in the office/residential scenario seem to be confirmed.

The benefit derived from a higher cardinality of CCs varies according to the number of dominant interferers seen by the users. In case *a)*, for example, the best performance in outage is achieved for the configuration with 4 CCs, that is the number of maximum active APs in the scenario. Considering the activation of a larger number of APs, as in cases *b)* and *c)*, further fractioning the spectrum can provide additional gains, even though minimal. The performance improvement given by the fractional reuse of the spectrum is appreciable when the clique size in the network is lower (or at least comparable) than the resource cardinality. On the contrary, in a very crowded scenario, such as in scenario *c)* where 12 APs are active, the differences between the various reuse schemes are minimal. Even with a high CCs cardinality, the system is not capable of orthogonalizing the overwhelming interference thus very poor performance is achieved in outage. Deployment case *d)* aims at investigating the impact of the APs deployment inside the rooms

Table 6.9: NJV14 Scenario analysis: normalized downlink cell throughput in the network.

Deployment	Scheme	Outage	Avg	Peak
a) APs in the hall (low-density)	Reuse 1	0%	6.9%	30.1%
	ACCS 2CCs	0.6%	11.1%	45.4%
	ACCS 3CCs	1.2%	16.7%	33.3%
	ACCS 4CCs	6.2%	18.4%	42.3%
	ACCS 5CCs	5.6%	18.1%	40.1%
	ACCS 6CCs	4.2%	17.8%	50%
b) APs in the hall	Reuse 1	0%	7.2%	24.3%
	ACCS 2CCs	0%	8.1%	22.1%
	ACCS 3CCs	0.3%	10.5%	31.6%
	ACCS 4CCs	0.5%	13.1%	25%
	ACCS 5CCs	0.9%	14.7%	25.4%
	ACCS 6CCs	2.8%	15.3%	29.3%
c) APs in the hall (high-density)	Reuse 1	0%	3.3%	13.4%
	ACCS 2CCs	0%	3.4%	13.3%
	ACCS 3CCs	0.2%	3.6%	13.1%
	ACCS 4CCs	0.3%	3.9%	13.7%
	ACCS 5CCs	0.3%	4.4%	14.7%
	ACCS 6CCs	0.4%	5%	16.8%
d) APs in the rooms	Reuse 1	0%	7.9%	27.2%
	ACCS 2CCs	0%	9.1%	31.2%
	ACCS 3CCs	0.2%	10.8%	32.8%
	ACCS 4CCs	0.3%	13.1%	25%
	ACCS 5CCs	0.7%	14.2%	29.4%
	ACCS 6CCs	1.5%	14.6%	30%

surrounding the hall. Even though the presence of walls should in principle reduce the interference between multiple APs, results show very limited variations in respect to scenario *b*) with the same number of nodes. A possible explanation can be found by looking at the building geometry: since the majority of the users are located in the center hall while the APs are in the surrounding rooms, no significant differences exist on the AP-to-UE links in terms of wall crossing and average distance. In this sense, assuming the AP transmission power to be sufficiently high in respect to the average path loss on the links, the SINR at the user is not affected significantly.

Results from the hybrid-simulation analysis in the NJV14 scenario allowed to verify the critical interference conditions which may arise in open-area/mall type buildings. In this environment, the deployment of user terminals and APs is typically characterized by the presence of a large number of LOS links. Adopting FD-ICIC mechanisms, such as ACCS, can provide capacity improvements to the users. The numerical gains, however, are generally low comparing to office/residential scenarios. In an indoor open-area scenario it is difficult to achieve a good spatial separation between multiple cells. In ultra-dense deployment conditions, the number of strong interferers may be then too high to be managed solely by a fractional reuse of the spectrum. The use of additional mechanisms enabling to further decrease the impact of strong interferers (e.g. directional antenna solutions, advanced receivers for interference cancellation) may be then indispensable to achieve very high user capacity targets.

6.7 A testbed for Interference Rejection Combining

The experimental activities discussed in this thesis mainly focused on the validation of distributed schemes for FD-ICIC. Interference coordination is, however, just one of the multiple options currently being investigated, for tackling the inter-cell interference problem in 5G systems. A research topic currently receiving major attention is advanced receivers for inter-cell interference suppression, in particular, interference rejection combining (IRC), and Successive Interference Cancellation (SIC)). In this project, early experimental activities with IRC receivers are described, aiming at providing an insight on how the developed experimental tools and methodologies for FD-ICIC, can be adapted also to the analysis of other local area wireless concepts.

IRC receivers aim at tackling the interference problem by exploiting the degrees of freedom of multiple antenna transceivers. The concept of IRC is to project the significant interfering streams over an orthogonal subspace, with respect to the desired signal, such that their detrimental impact can be diminished. MIMO

configurations allow a trade-off between spatial multiplexing gain and interference resilience: assuming N antennas to be available, a system featuring IRC receivers may decide whether to use up to N parallel data streams for communication or, alternatively, to reject up to $N - 1$ interferers (i.e. leaving only 1 stream for communication). In dense cellular network deployments this option is particularly attractive because it allows the terminals to adapt to variable topology conditions and thus canceling the impact of multiple closely located interferers.

In order to properly reject the interfering streams, IRC receivers require an accurate estimation of the Interference Covariance Matrix (ICM) [79]. The ICM is obtained by analyzing the complex (i.e. phase and magnitude) response of the channel, discriminating among the multiple received streams. An effective use of IRC requires, moreover, the ICM estimates to be frequently updated. Specific challenges in this sense, relate to bursty data-traffic conditions and uncoordinated TDD transmissions (i.e. the unsynchronized DL-UL switching point between independent cells).

The objective of the first experimental trials with IRC receivers, in this thesis, has been the proof-of-concept, in practical deployment scenarios. A MIMO testbed with multiple network nodes has been realized, and hybrid-simulation trials (i.e. where multi-link complex channel estimations have been utilized) have been performed. The obtained results have shown the potential of IRC receivers for capacity improvements in respect to traditional Maximal Ratio Combining (MRC) receivers, confirming similar findings previously presented in literature [80]. For a more detailed discussion of the trials as well as the obtained results, we invite the reader to refer to Appendix A.

6.8 A testbed for a distributed nodes synchronization

Time and frequency alignment between neighboring cells is a fundamental requirement for enabling efficient interference mitigation techniques in ultra-dense deployment scenarios [81]. In particular, solutions based on advanced baseband processing can be made effective only if active cells are time synchronized within a very small time interval (e.g. a fraction of the Cyclic Prefix (CP) duration in the case of an OFDM-based system). As previously discussed in this thesis, cellular network deployments in indoor environments may face several limitations in terms of backhaul infrastructure. Moreover, contrarily to outdoor deployments where GPS-based systems can be utilized for providing a common and stable time reference to all nodes, the same opportunity is typically not available inside buildings. For this reason, the network synchronization problem is another area where distributed approaches may provide useful contribution, in the context of 5G local

area network deployments.

In [14] a possible solution to the distributed synchronization problem has been investigated. An algorithm has been proposed, aiming at maintaining the time alignment of the nodes with high accuracy in the long term despite of the non-idealities of the hardware clocks. The concept relies on the exchange of beacon messages among the nodes, which then react by correcting their transmission time in order to progressively achieve a network-wide time alignment. Preliminary works aiming at the experimental validation and proof-of-concept of this algorithm proposal have been included as part of this thesis.

A testbed supporting the transmission/reception of beacons, as well as the periodical correction of the time alignment at the nodes, has been realized. Similarly to all previous testbed configurations, the synchronization testbed also relies on the [USRP](#) hardware and the [ASGARD SDR](#) platform for the system design and run-time execution. Experiment trials have been conducted with the testbed in indoor office environment. Collected results, in terms of global time misalignment across the network, allowed to verify the concept feasibility even in presence of a hardware configuration with low-end timing accuracy characteristics. Moreover, the time misalignments results proved to be in line with prior indications obtained from simulation-based studies. In this sense, the trials allowed to confirm once-again, the reliability of common simulation model assumptions (e.g. path loss models) for the analysis of indoor wireless network deployments. The detailed description of the experimental activities with the distributed synchronization testbed has been reported in [Appendix B](#).

6.9 Summary

In this chapter experimental activities with distributed network concepts in local area wireless networks have been presented. The validation of a specific algorithm solution for distributed [FD-ICIC](#), named [ACCS](#) has been the main focus. The general problem of [FD-ICIC](#) has been first discussed, aiming at highlighting objectives and critical elements for the performance evaluation of such concepts. The [ACCS](#) testbed, realized with components from the [ASGARD](#) platform, has been described in detail. Both live execution experiments and hybrid-simulation have been employed for the validation of the [ACCS](#) performance. Experiments focused on the impact of fundamental configuration system parameters, e.g. the [CCs](#) cardinality, as well as on the analysis of network topologies and dynamic propagation environments. The obtained results allowed to demonstrate the feasibility of a distributed [FD-ICIC](#) scheme, as a solution for the interference mitigation in random wireless network deployments in local area. Critical elements for the system performance and execution have been also discussed. The results from the exper-

iments have been also compared to prior work in literature based on simulations. The correspondence of the obtained insights (e.g. in terms of cell throughput gains delivered by ACCS in respect to a frequency reuse 1 scheme), suggest that the common assumptions adopted in simulations—in relation to the scenario modeling—provide a reliable support for the performance analysis of indoor wireless network deployments.

Conclusions and Future Work

7.1 Summary and Conclusions

The ultra-dense deployment of small cells is expected to be a fundamental characteristic of next-generation 5G cellular networks —enabling to achieve very large user capacity in local area. The management of network deployments in indoor environments is hindered, however, by several challenges in the resource planning (e.g. the location of user-deployed access points (APs) cannot be foreseen in advance) as well as by the difficulties in pursuing a centralized optimization of the configuration parameters (i.e. mainly due to the difficulties in providing, ubiquitous, high-speed backhauling inside buildings). In this context, the achievement of the 5G performance targets may be at risk. Aiming at providing effective solutions to such problems, distributed approaches to the network management have been recently proposed in literature.

In dense indoor network deployments, the interference caused by neighboring cells sharing the same spectrum resources is considered one of the major limiting factors to the system performance. Distributed algorithms for the inter-cell interference coordination in the frequency domain (FD-ICIC) may provide, in this sense, useful contribution, enabling the APs in the network of dynamically adjusting their resource occupation according to the perceived interference conditions. In literature, the performance evaluation of FD-ICIC schemes —as well as of other distributed network solutions— is typically carried out by means of system-level simulations,

where random network deployments are analyzed in reference scenario models. The performance of **FD-ICIC** schemes, however, is very sensitive to the deployment scenario assumptions. In indoor environments, the building geometry and specific signal propagation characteristics, affect the network topology and thus the number and strength of interferers in the network. Since the interference mitigation capabilities of **FD-ICIC** schemes depend on the possibility of orthogonalizing only a limited amount of interferers, an inaccurate representation of the network topology may negatively affect the reliability of performance studies conducted with simulations. In order to improve the overall validation process, simulation-based results should be verified on the field, with practical experiments.

The experimental analysis of distributed network concepts in local area small cells is a relatively new research area in wireless communications. In literature, experimental activities with a similar scope (i.e. short-range wireless communication in indoor environments) have been carried out mostly in relation to multi-hop/mesh/sensor networks and WiFi systems. The objective of this thesis is to enable the experimental validation of concepts by discussing the challenges, and defining tools and methodologies for the setup and execution of trials. The main research focus of experiments in this thesis has been the performance validation of a distributed **FD-ICIC** scheme, named Autonomous Component Carrier Selection (**ACCS**). Moreover, early activities with **IRC** receivers and distributed synchronization algorithms have been also included, as examples of further applications of the developed experimental approaches to **5G** local area concepts.

In this thesis a *new software defined radio framework* —**ASGARD**— has been first developed, enabling the realization of wireless testbeds for distributed network concepts and, more in general, the design of system prototypes based on **SDR**. **ASGARD** adopts a component-based development approach where a set of basic-software interfaces allow the developer to manage the fundamental elements of a communication system architecture (i.e. data-flows, threads of execution, memory allocation, network connectivity, etc.). The main contribution of **ASGARD** is enabling the design of reconfigurable, cross-layer communication system architectures, as well as enabling the control of experimental trials with large, multi-node testbeds.

The validation of distributed network algorithms is a problem complex to tackle, since a wide range of elements (e.g. single-link channel propagation, multi-link deployment characteristics, runtime interactions between multiple decision-making processes) concur to the overall system performance. Addressing all these aspects at the same time during a single experimental campaign would in principle require an unfeasible amount of trials, of long duration. Aiming at overcoming these practical challenges, specific *execution methodologies* have been defined in this thesis.

The analysis of the runtime execution aspects with the systems (e.g. impact of

terminals mobility, dynamic propagation environments) has been addressed by considering the *live execution* of the concepts directly on the testbed hardware. On the other hand, the analysis of multiple network deployments (as well as other large-scale, multi-link network aspects), has been achieved by employing *hybrid-simulations*.

Hybrid-simulations exploit on-field link path loss measurements as the input for more realistic system-level simulations. In this project, two *path loss measurement campaigns* have been carried out for hybrid-simulation purposes. A channel sounder type of testbed has been then developed, supporting the analysis of multiple wireless links in large network deployments. Two different scenarios have been considered: indoor office and indoor open-area/mall-type. More than 2000 links have been measured in total during the experimental campaigns with the channel sounder testbed.

The experimental path loss data enabled the *evaluation of simulation modeling inaccuracies* in respect to the large-scale statistical properties of random network deployments in indoor scenarios (e.g. average path loss towards interfering APs, SIR at the users). The obtained results, allowed to establish that despite stochastic models may have a limited accuracy in predicting the single-link path loss, their negative effects on the large-scale characteristics of the network —e.g. the ratio between the useful signal at the users and the total interference— are largely compensated. In this context, the geometry of the considered deployment scenarios also plays a key role in defining the average number and strength of significant interferers, in a multi-cellular configuration.

In this thesis, the experimental activities mainly focused on the *performance validation* of the ACCS algorithm. A *testbed has been realized* (relying on the AS-GARD SDR platform), enabling the live execution of the algorithm in a cellular network context. Live execution experiments with ACCS focused on the *proof-of-concept* as well as on the performance analysis in dynamic propagation environments. Results obtained from the trials essentially confirmed the suitability of ACCS as a solution providing interference mitigation in local area small cell deployments. Critical elements for the concept improvement have been also identified. In particular, the ACCS decision-making process proved to be sensitive to the fixed decision-making thresholds which are difficult to calibrate in dynamic propagation environments, thus leading to potentially sub-optimal resource allocation. The periodicity of the algorithm execution is also a key element —determining the system capabilities of reacting (or being resilient) to variations in the network topology and channel conditions. Moreover, the details of the algorithm policies for the de-allocation of resources require further investigation, since, in high load traffic conditions, they may lead to high variations in the offered capacity between interference-coupled cells.

A second aspect about ACCS addressed in this thesis relates to the *validation of*

prior simulation-based findings presented in literature. In order to achieve this target, hybrid-simulations have been employed —enabling to analyze a large number of random network deployments in realistic operating scenarios. The obtained results have shown that **ACCS** can deliver comparable capacity gains—in respect to the literature—to interfered users, in both indoor office and open-area/mall-type deployment scenarios. The algorithm has shown in general good capabilities of coping with a wide range of interference conditions, enabling both the protection of highly-interfered users as well as the exploitation of larger bandwidth allocations for users experiencing higher **SINR**.

Early experimental activities with **IRC** receivers and synchronization algorithms have also been included in this thesis, providing examples of the application of the developed experimental approaches to other research concepts for local area small cells.

7.2 Recommendations and guidelines

The execution of experiments allows to verify the reliability of novel concepts in practical operating conditions. At the same time, it also helps in identifying critical performance issues as well as in individuating areas for future improvements. The setup and execution of trials with wireless networks testbeds is, however, typically difficult to put in practice. In order to facilitate the realization of testbeds and ease the management of trials, the following aspects are worth considering:

- **Select the best hardware for your needs.** Quality of the **RF** components and processing capabilities are not the only characteristics to take into account when selecting the hardware configuration for the testbed. Design flexibility, runtime reconfigurability as well as cost-effectiveness may also be critical for the setup of experiments, particularly in the case of distributed network concepts.
- **Plan, plan, plan.** The installation and deployment of the hardware may become the most challenging task to accomplish when running experiments. This problem tends to increase exponentially at the increase of the number of nodes in the testbed. Prior planning is the key to minimize the overhead and ensure that complex experimental campaigns will not require an unfeasible amount of trials or time.
- **Divide and conquer.** The longer and more complex trials are, the more likely is that errors and failures may occur. For this reason, it is recommended—whenever possible—to split a long experimental/measurement campaign, into multiple, focused and short runs, easier to control.

- **Check early, check often.** Given the complexity and duration of trials it is important to ensure that, eventually, the obtained results are fully reliable. By verifying as early and as frequent as possible, whether the recorded measurements/KPIs/results are within reasonable range it is possible to determine on time if any repetition is needed. A practical solution in this sense is to develop test/check routines which can be directly executed on the field at the end of every run.

The performance analysis of cellular network deployments requires a large number of nodes and cells to be considered in order to capture the complexity of interactions which may occur in the real-world. According to the deployment assumptions used in the experiments, the significance of the obtained results may vary. One critical aspect relates to the evaluation of the system performance in the “*worst/best cases*”. How shall this be interpreted? In Monte-Carlo simulations the overall network statistics are obtained by aggregating results from a very large amount of random network deployments in a given scenario. As a result, the performance of, e.g. the worst 5% of the users, is a direct consequence of the deployment environment characteristics (i.e. spatial density of the cells, building geometry, channel propagation). In an experimental context, instead, since a much more limited amount of nodes spatial drops can be evaluated, the same performance metric (i.e. the 5-th percentile) should be more carefully interpreted. The testbed deployment assumptions in the experiments have a fundamental impact in determining the possible range of network performance results. In order to setup experimental trials where the significance of the results can be more clearly determined, the following approaches can be considered:

- **Realistic deployment.** Deploying APs and UEs as they would be expected to be in the specific environments considered. This approach can deliver realistic insights about the overall system performance (i.e. also in relation to worst/best cases) in a real operative scenario. However, the obtained results tend to be location-specific thus a large number of configurations should be analyzed for greater statistical significance.
- **Toy scenarios.** Very specific node configurations can be adopted in order to evaluate the system performance in critical situations —under precise operating conditions. In this case, the acquired results should be not interpreted as general for the network rather than specific to, for example, the topology, time, or channel conditions considered.

The path loss data acquired in this project essentially confirm the suitability of reference path loss models and building scenarios as tools for the performance analysis of indoor network deployments. Although offsets in the single-link path loss prediction may exist, the overall effect on the system performance, e.g. SINR,

is in large part compensated on a network-scale. This kind of effect, however, can be considered reliable only when comparing scenarios (between simulations and experiments) with similar geometrical properties. The building geometry constrains the deployment of both APs and user devices, thus —on top of minor path loss offsets— the number and strength of interferers tends to be related over a certain area of space.

From the perspective of performance evaluation of distributed FD-ICIC solutions, and particularly referring to ACCS, the following considerations can be made, based on the results of experiments and hybrid-simulations:

- **Not all interference looks the same.** The interference characteristic in terms of number and relative strength of interferers, have a fundamental impact on the interference mitigation capabilities of FD-ICIC schemes. In geometrically regular scenarios, e.g. office/residential, the number of significant interferers can be more easily predicted, based on the physical configuration of rooms/apartments. Predictable network topologies may ease the optimization of the system configuration in FD-ICIC schemes. On the other hand, for the opposite reason, the performance in open-area deployments appears to be more problematic, due to the reduced spatial separation between the cells.
- **Time domain is a challenge.** Distributed FD-ICIC schemes are capable of adapting to different network topologies, thus coping with a wide range of deployment configurations of the nodes. However, ensuring a reliable performance in time (i.e. tracking variable propagation conditions, mobility of the terminals, data traffic burstiness) remains a critical aspect to be further investigated. In particular, the utilization of fixed decision-making thresholds appear to be sub-optimal in dynamic environments. The temporization of the algorithm execution is also critical, since this aspect has a direct impact on the system capability of reacting (or be resilient) to sudden changes in the scenario.
- **Support integration with other techniques.** Findings from the experiments indicate that in ultra-dense deployment scenarios, the orthogonalization of interference in the frequency domain may not be always sufficient for guaranteeing the desired performance targets. For this reason, the design of FD-ICIC solutions should consider the possibility of being integrated with other interference-mitigation solutions, e.g. PHY-level interference cancellation with multiple-antenna configurations.

7.3 Future Work

The experimental validation of distributed network algorithms in local area is still a relatively new research field. One of main challenges to the execution of trials is represented by the cost and complexity in the development of large network testbeds. The continuous improvement of **SDR** hardware solutions and software platforms promises to facilitate these tasks in the future. Key elements, in this sense, are a reduced complexity of the system design and a greater re-usability of the implemented features.

In relation to the **ASGARD** platform, wide margins for improvement currently exist at various levels of the framework. In first place, further developments are needed in order to better exploit the available processing resources on modern host computers. In particular, supporting the **PHY**-layer demands of **5G** concepts (e.g. multiple data streams, live complex channel estimations) is likely to require an optimized data transfer and improved management of thread priority settings and CPU parallelism. Furthermore, in order to improve the re-usability and the expansion of the implemented library of features, additional interfaces for managing the **AsgardSystem** and **AsgardApplication** abstractions are also required. Although the rapid development of commercial **SDR** solutions (e.g. National Instruments LabView [82]) promises to achieve unrivaled levels of support in the long term, the contribution provided by open-source platform is still relevant in an academic context —providing opportunities for collaboration in research projects as well as for teaching purposes.

The experimental activities with **FD-ICIC** algorithms discussed in this thesis, served as a starting point for the evaluation of a wider range of techniques for local area small cells network deployments. Considered the key role of **MIMO** antenna solutions, in the **5G** scenario, future testbed activities will necessarily target the validation of such concepts. In particular, the development of **IRC** techniques is currently the main focus of the activities at Aalborg University. In respect to the initial trials presented in this thesis, more complex analysis with a larger number of testbed nodes and higher-order antenna configurations (e.g. 4x4) are going to be investigated.

More in general, the following topics have been considered relevant for the experimental investigation with the testbed, in the framework of **5G** studies:

- the rank adaption (i.e. the possibility of dynamically select the number of data streams to be transmitted) in presence of advanced receivers capable of **IRC**
- **SIC** receivers

- the combination of interference coordination and interference suppression techniques at the receiver side
- the dynamic UL/DL scheduling in TDD systems.

In this context, critical challenges for the testbed design and execution of experiments are expected to be:

- the management of the computational complexity given by multiple, high-rate data streams
- the PHY-level synchronization of the multiple MIMO streams at the nodes
- the network-level synchronization required for correctly estimating the phase of signals received from multiple transmitters
- the evaluation of the “*flashlight effect*” (i.e. the fluctuations in the received interference power, e.g. due to unpredictable interference patterns, which can typically reduce the performance gains [83]) in practical deployment conditions.

Experimental activities should be considered as one part of a wider process for the validation of new theoretical proposals. Integration with analytical and simulation-based studies should therefore always be pursued. Experimental methodologies and execution approaches should be continuously adapted, evaluating —case by case— the specific objectives of the validation.

A testbed for Interference Rejection Combining

While **FD-ICIC** solutions tackle the interference problem mainly at **RRM** level, **IRC** focuses on the **PHY** layer. **IRC** receivers exploit the degrees of freedom of multiple antenna receivers, for projecting the significant interfering streams over an orthogonal subspace with respect to the desired signal, thus diminishing their detrimental impact. **MIMO** configurations allow a trade-off between spatial multiplexing gain and interference resilience: assuming N antennas to be available, a system featuring **IRC** receivers may decide whether to use up to N parallel data streams for communication or, alternatively, to reject up to $N - 1$ interferers (i.e. leaving only 1 stream for communication). In dense cellular network deployments this option is particularly attractive because it allows the terminals to adapt to variable topology conditions and thus canceling the impact of multiple closely located interferers.

In order to properly reject the interfering streams, **IRC** receivers require an accurate estimation of the **ICM** [79]. The **ICM** is obtained by analyzing the complex (i.e. phase and magnitude) response of the channel, discriminating among the multiple received streams. An effective use of **IRC** over requires the **ICM** estimates to be frequently updated. Specific challenges in this sense relate to bursty traffic conditions and uncoordinated **TDD** transmissions (i.e. the unsynchronized **DL-UL** switching point between independent cells).

The benefits of **IRC** receivers in small cell deployments have been discussed in [80].

In this contribution the authors rely on a specific transmission framing structure, which assumes:

- aligned DeModulation Reference Signal (**DMRS**) with orthogonal reference sequences
- identical **UL/DL** transmission format for dealing with cross-link interference
- interference patterns constant within the frame duration, in order to properly tune the **IRC** filter with the current **ICM** estimate

In this context, all receivers can estimate the channel responses for all relevant streams at the same time, thus improving the **ICM** accuracy and the **IRC** effectiveness. In [80] performance evaluation studies have been performed with system level simulations, showing significant throughput gains of **IRC** in respect to traditional—interference unaware—**MRC** receivers. The objective of the experimental trials described in this section is then to verify the obtained performance insights in practical deployment conditions. Part of this work has been included in the following conference paper, currently under review for publication:

- Dereje A. Wassie, Gilberto Berardinelli, Fernando M. L. Tavares, Oscar Tonelli, Troels B. Sørensen and Preben Mogensen, “Experimental Evaluation of Interference Rejection Combining for 5G small cells”, *IEEE Wireless Communications and Networking Conference*, New Orleans -LA, 2015. *Submitted for publication.*

A.1 Testbed setup and experiments

The developed testbed setup for the analysis of **IRC** receivers is based on the same hardware components previously utilized for the **ACCS** testbed. In particular, the **USRP** N200 motherboards and the **XCVR** 2450 daughterboards are the main radio elements. The key difference with the previous experiences is the presence of a **MIMO** system configuration which enables the transmission of multiple streams and the estimation of the complex channel response. The employed setup is shown in Figure A.1. The **USRP** hardware enables the execution of 2x2 **MIMO** features by utilizing two motherboards connected through a **MIMO** Cable. In this configuration one of the two devices acts as *master* and the other as *slave*. The master communicates with the host computer and controls the streaming of data to and from the slave. The purpose of the **MIMO** cable is then to enable such operations also providing the master clock reference to the slave.

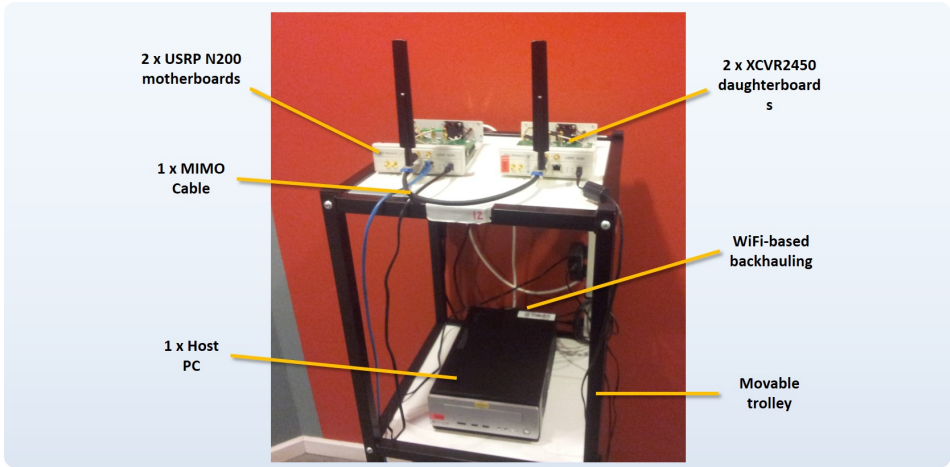

Fig. A.1: MIMO testbed setup utilized for the evaluation of IRC concepts.

The goal of the testbed is to prove the capabilities of IRC receivers in improving the throughput of cellular deployments in interference limited deployment scenarios. Given the availability of the hardware (i.e. at the time of the experiments consisting of 16 USRP boards), a setup with 4 cells has been considered in the experiments. Every cell is formed by 1 AP and 1 UE for a total of 8 MIMO nodes. In the trials here described the testbed has been used in channel-sounding mode. The system design mainly relies on the architecture presented in Section 4.5.4 with the addition of processing components for the complex channel estimation and the generation of ICMs. The two USRP boards at each node are configured for transmitting two orthogonal pilot sequences in the frequency domain, which occupy a different set of OFDM subcarriers. At the receiver side, the channel frequency response is computed over the pilot positions and then linearly interpolated in order to obtain a response across the entire operating bandwidth. The transmission bandwidth is 3.125 MHz while the transmit power is set at 10 dBm.

The complex channel estimation in respect to multiple nodes is achieved by enabling TDD transmission frame during which every node in the testbed is transmitting for a single time slot period while all other are receiving. This mechanism is totally compliant with the scheme previously presented in Figure 4.7. The generated channel estimations at each node are sent to a testbed server, through a backhaul connection (Ethernet or WiFi), for the centralized logging of the data. The time reference for the synchronized TDD operations is provided by the NTP service on the host computers. The accuracy of the NTP is in the order of tens on milliseconds, and therefore poses a constraint on the minimum duration the time slots. In the experiments described in this section, the time slot duration is set to 0.2 seconds. With 8 nodes in the network, 8 time slots are required for estimating

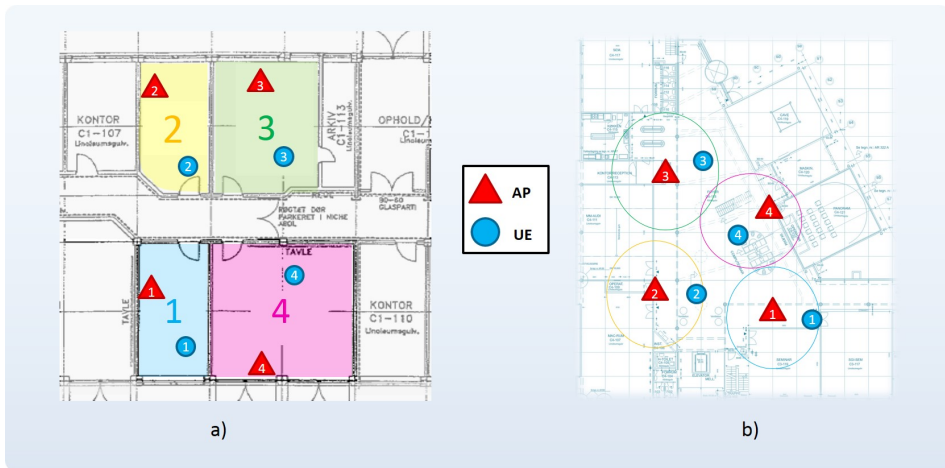

Fig. A.2: Experimental scenarios and nodes deployment for the IRC experiments.

the entire 8×8 complex channel matrix. The total frame duration sums up to 1.6 seconds.

Multiple trials with the testbed have been performed in both office and open-area/mall type scenarios. 4 cells have been deployed across the premises of the NJV12 and NJV14 buildings at Aalborg University, as depicted by the plans in Figure A.2.a and A.2.b. In scenario *a*) we assume the cells to operate in CSG mode, i.e. each UE is connected to the AP in the same room. In scenario *b*), instead, the mode of operation is OSG, i.e. the UEs connect to the AP providing the best signal. For every drop of the testbed network, the complex channel estimates are computed in respect to all links in the network and the system performance is analyzed. Multiple testbed drops have been considered during the trials. For scenario *a*) multiple nodes positions have been analyzed, assuming every couple of nodes in each cell to be re-located within the same room. In scenario *b*) instead, multiple node locations have been identified within the area inscribed by the circles of Figure A.2.b. Furthermore, in order to collect data affected by different multipath propagation conditions, trials have been repeated over a set of 40 different carrier frequencies in the 4.91 GHz to 6 GHz band.

A.2 Performance Evaluation

The acquired complex channel matrices are utilized in the post-processing as an input for the SINR computation in hybrid-simulations. SINR estimates have been generated for multiple receiver configurations: besides IRC, MRC receivers have

also been considered as term of comparison. **MRC** receivers allow to maximize the power of the desired signal but are unaware of multiple interfering streams. Eventually, the **SINR** estimates for every receiver configuration are mapped over capacity by employing Shannon’s formula [84]. Results have been generated limitedly to the downlink, assuming full buffer data traffic conditions.

A summary of the obtained results for the NJV12 office scenario is presented in Table A.1. Results for NJV14 open-area scenario are collected in Table A.2. On top of **IRC** and **MRC** configurations, multiple frequency reuse combinations have also been analyzed, aiming at investigating the joint effect of interference rejection and coordination. Given the number of cells available and the degrees of freedom for **IRC**, only Reuse1 and Reuse2 schemes have been considered relevant in this analysis. Values in the table are reported in terms of normalized cell throughput. A value of 100% is assumed to be the maximum theoretical throughput that can be achieved in a configuration considering rank 1 transmission, i.e. an unique data stream mapped over the two antennas by a (fixed) precoding matrix. Since Reuse 2 only utilizes half of the maximum available bandwidth, the maximum normalized throughput achievable in this case is 50%. The table shows results for outage users (i.e. the worst 5% of the users), median (i.e. 50-th percentile of the total users) and peak performance (i.e. only 5% of the users achieve a better performance).

Table A.1: Normalized cell capacity - office scenario (a)

Scheme	Configuration	Outage	Average	Peak
Reuse 1	MRC	19%	49%	78%
	IRC	26%	60%	88%
	<i>Gain</i>	36%	22%	12%
Reuse 2	MRC	24%	41%	50%
	IRC	32%	47%	50%
	<i>Gain</i>	33%	14%	0%

With 2 antennas available, the considered **IRC** configuration can cancel up to 1 interferer (for rank 1 transmission). In this sense, the benefit given by **IRC** receivers is maximum in those deployment circumstances where a single interferer dominates over the others. The experimental results reported Table A.1 and Table A.2 show general gains given by **IRC** receivers, in respect to interference unaware **MRC**, for all cases considered. Higher relative gains are achieved for outage users, in a frequency Reuse 1 configuration. With Reuse 2 part of the interference is orthogonalized in the frequency domain, thus the benefits of **IRC** are lower. In terms of absolute outage capacity, however, the best performance is achieved when both fractional spectrum reuse and interference cancellation are utilized. From the perspective of average cell capacity and peak performance, a Reuse 2 approach

Table A.2: Normalized cell capacity - open-area/mall-type scenario (b)

Scheme	Configuration	Outage	Average	Peak
Reuse 1	MRC	9%	29%	55%
	IRC	14%	40%	75%
	<i>Gain</i>	68%	40%	36%
Reuse 2	MRC	14%	28%	44%
	IRC	22%	40%	50%
	<i>Gain</i>	55%	43%	11%

shows strong limitation given the reduced bandwidth allocation.

Other interesting insights can be obtained by comparing the results between office and open-area/mall-type scenarios. In the first case, higher capacity results suggest a generally less interfered scenario. At the same time, lower IRC gains also suggest that the characteristic of interference are such that the Dominant interferer to Interference Ratio (DIR) is low compared to the open-area case. In order to validate this indication, the DIR CDFs, calculated for Reuse 1 case for both the scenarios have been analyzed and are presented in A.3. Higher DIR values are experienced in the open-area deployment case, thus justifying the better IRC performance (e.g. the fact that multiple UEs can connect to the same AP may reduce the number of potential interferers and then enhance the DIR).

A.3 Discussion

The presented experiments with the IRC testbed provided an initial proof-of-concept for IRC receivers in practical deployment conditions. The obtained results in both office and open-area scenarios have shown potential for capacity improvements in respect to traditional MRC receivers. A challenging aspect to evaluate is the effect of the joint adoption of fractional frequency reuse schemes and IRC. In particular, the degrees of freedom for IRC receivers and the cardinality of the fractional spectrum reuse are to be evaluated in relation to the interference conditions (i.e. number of significant interferers, DIR) given by the deployment scenario. Overall, given the difficulties in predicting the interference conditions in indoor deployment scenarios, the availability of multiple interference mitigation solutions can provide the necessary flexibility for achieving an effective system optimization.

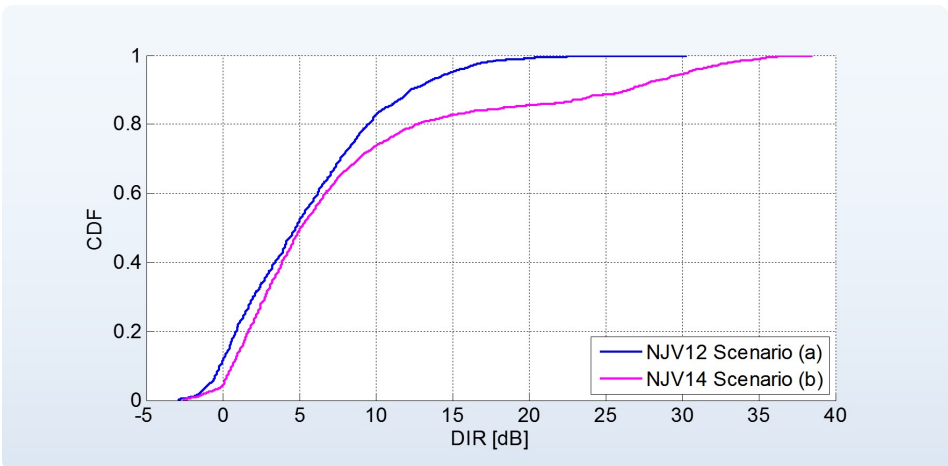

Fig. A.3: Cumulative distribution functions of the DIR experienced at the users. Results relate to a frequency Reuse 1 scheme.

A testbed for a distributed nodes synchronization

Time and frequency alignment between neighboring cells is a fundamental requirement for enabling efficient interference mitigation techniques in ultra-dense deployment scenarios [81]. In particular, solutions based on advanced baseband processing can be made effective only if active cells are time synchronized within a very small time interval (e.g. a fraction of the CP duration in the case of an OFDM-based system). As previously discussed in this thesis, cellular network deployments in indoor environments may face several limitations in terms of backhaul infrastructure. Moreover, contrarily to outdoor deployments where GPS-based systems can be utilized for providing a common and stable time reference to all nodes, the same opportunity is typically not available inside buildings. For this reason, the development of distributed approaches to the network synchronization problem is another area which is experiencing great attention, in the framework of 5G research.

B.1 Distributed runtime synchronization algorithm

In [14] a possible solution to the distributed synchronization problem has been investigated. An algorithm has been proposed, aiming at maintaining the time alignment of the nodes with high accuracy in the long term despite of the non-

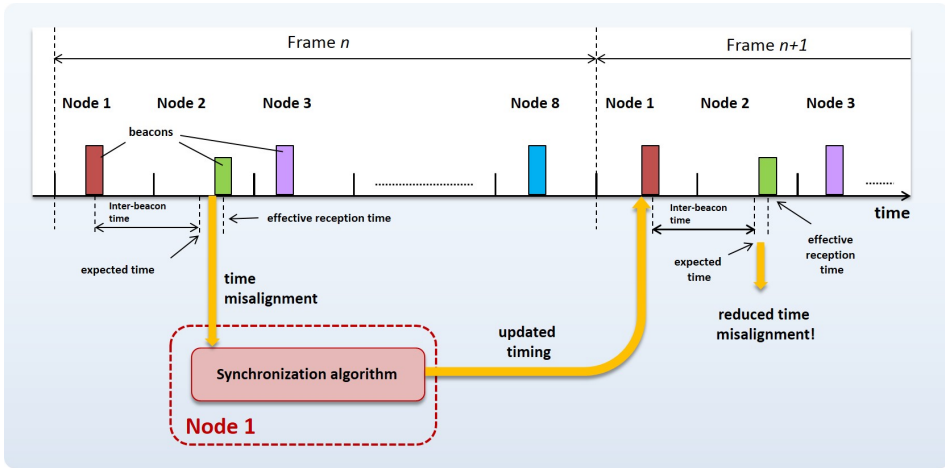

Fig. B.1: Basic functioning of the distributed synchronization algorithm. Multiple nodes in a network periodically transmit a beacon which is locally utilized to correct the time misalignment

idealities of the hardware clocks. The algorithm is based on the exchange of beacon messages among the nodes, which react by correcting their transmission time in order to progressively achieve the time alignment. An initial coarse synchronization is assumed, in the order of few milliseconds. The goal of the algorithm is then to reduce the misalignment down to μs levels and maintain it in the long term despite of the inaccuracy of the hardware clocks.

A scheme depicting the synchronization process of the distributed algorithm is provided in Figure B.1. The initial synchronization defines a frame structure where the nodes are sending their beacon messages in a round robin fashion. When a node is not transmitting, it receives the beacons sent by the neighbor nodes. The beacon messages are generated as CAZAC sequences [85]; at the receiver side, the signal is correlated against a local copy of the same sequence and the position of the peak of the correlator output denotes the receive timing. Given the limited timing accuracy, each node receives the beacon messages sent by the neighbors either in advance or delay with respect to the expected timing given by the frame design. Upon reception of a beacon, each node measures the error with respect to the expected timing. This information is then fed to the synchronization algorithm running at each node, which outputs a corrected transmission time aiming at progressively reduce the misalignment error among the neighbor nodes.

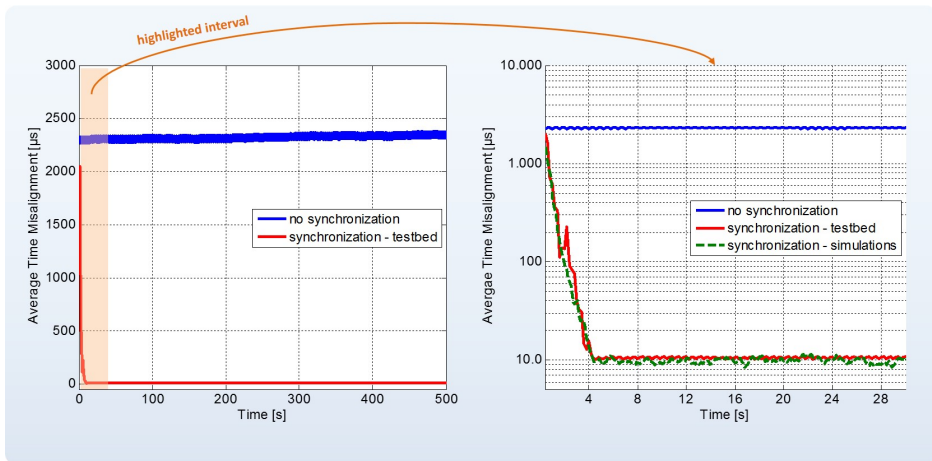

Fig. B.3: Average time misalignment in the testbed network (8 nodes in LOS)

result a time correction factor is estimated and utilized to align the time framing at the UhdComm. In parallel, the clock misalignment information is also forwarded to a `SystemControl` unit which is communicating to the central testbed server. The `SystemControl` is also utilized to interpret control commands from the testbed server (or `GUI`) and trigger reconfiguration of settings parameters in the system.

B.3 Experimental results

The objective of the synchronization experiments here described is to provide an initial proof-of-concept for the algorithm. The trials have been conducted in the office premises of the NJV12 building at Aalborg University (Figure 5.1.a) by deploying the nodes in a large room. 8 nodes have been employed in the experiments. The setup considers all links to be in `LOS` thus allowing to minimize the eventual beacon losses due to poor signal reception. Static propagation environment conditions are assumed for the entire duration of the trials. The boards operate at a carrier frequency of 5 GHz, and the inter-beacon time is set to 200 ms, i.e. the total frame duration is 1.6 seconds. The initial synchronization for the nodes in the testbed is achieved by connecting the nodes to an `NTP` server.

Figure B.3 shows the results in terms of average time misalignment for both cases of no-synchronization and synchronization. As a term of comparison, the simulated time misalignment for an equivalent 8 nodes deployment and inter-bacon time is also reported. In the case of no-synchronization the average time misalignment is around 3-4 ms; this corresponds to the initial synchronization error given by the

[NTP](#) server. In case no correction procedures are taking place, the misalignment across the nodes will keep increasing due to the aforementioned limited accuracy of the [USRP N200](#) clocks. When our synchronization algorithm is running, the average time misalignment drops consistently to around $10 \mu\text{s}$, and is constrained to that level (please note that this value is due to the testbed hardware limitations in terms of minimum inter-beacon timing supported. Tighter inter-beacon timing may indeed enable a better performance). Despite the basic network deployment setup adopted in the experiments, the obtained results show an extremely good fit with simulations. These results provide a first important proof-of-concept for the algorithm capabilities. For a more comprehensive performance validation, however, more complex network topologies should be investigated as well as the impact of [PHY/RF](#) non-idealities for the transmission and reception of the synchronization beacons.

List of Acronyms

1G First Generation

2G Second Generation

3G Third Generation

3.9G 3.9 Generation

4G Fourth Generation

5G Fifth Generation

3GPP Third Generation Partnership Project

3GPP2 Third Generation Partnership Project 2

64QAM 64-Quadrature Amplitude Modulation

ACCS Autonomous Component Carrier Selection

A/D Analogue to Digital

AI Artificial Intelligence

AMC Adaptive Modulation and Coding

AP Access Point

API Application Programming Interfaces

ATDD Adaptive Time Division Duplex

AWGN Additive White Gaussian Noise

- BCC** Base Component Carrier
- BEE2** Berkeley Emulation Engine 2
- BEP** Bit Error Probability
- BER** Bit Error Rate
- BIM** Background Interference Matrix
- BLER** Block Error Rate
- BPSK** Binary Phase Shift Keying
- BS** Base Station
- CA** Carrier Aggregation
- CAZAC** Constant Amplitude Zero Autocorrelation
- CBR** Constant Bit Rate
- CC** Component Carrier
- CCI** Co-Channel Interference
- CDF** Cumulative Distribution Function
- CDMA** Code Division Multiple Access
- C/I** Carrier to Interference
- CO** Communication Objects
- CoMP** Coordinated Multi-Point
- CORNET** Cognitive Radio Network Testbed
- CP** Cyclic Prefix
- CPU** Central Processing Unit
- CQI** Channel Quality Information
- CR** Cognitive Radio
- CRC** Cyclic Redundancy Check
- CSG** Closed Subscriber Group
- CSMA/CA** Carrier Sense Multiple Access - Collision Avoidance
- CSMA** Carrier Sense Multiple Access
- D/A** Digital to Analogue

-
- DA** Data Aided Algorithm
- DAB** Digital Audio Broadcasting
- DAC** Digital to Analogue Converter
- DAS** Distributed Antenna System
- DCA** Dynamic Channel Allocation
- DFT** Discrete Fourier Transform
- DIR** Dominant interferer to Interference Ratio
- DL** Downlink
- DMRS** DeModulation Reference Signal
- DRP** deployment ratio probability
- DS** Direct Sequence
- DS³** Dynamic Spectrum Sharing with Selfishness
- DSA** Dynamic Spectrum Access
- DSL** Digital Subscriber Line
- DSP** Digital Signal Processor
- DSSS** Direct Sequence Spread Spectrum
- EC** External Components
- eNB** enhanced NodeB
- EVM** Error Vector Magnitude
- FD** Full-Duplex
- FDMA** Frequency Division Multiple Access
- FDD** Frequency Division Duplexing
- FD-ICIC** Frequency Domain Inter-Cell Interference Coordination
- FDPS** Frequency Domain Packet Scheduling
- FDS** Frequency Domain Scheduling
- FEC** Forward Error Correction
- FER** Frame Error Rate
- FFR** Fractional Frequency Reuse

- FFT** Fast Fourier Transform
- FM** Frequency Modulation
- FPGA** Field Programmable Gate Array
- FSU** Flexible Spectrum Usage
- GA** Genetic Algorithms
- GPF** Generalized Proportional Fair
- GPP** General Purpose Processor
- GPS** Global Positioning System
- GSM** Global System for Mobile communication
- GUI** Graphical User Interface
- HARQ** Hybrid Automatic Repeat Request
- HeNB** Home enhanced eNodeB
- HetNet** Heterogenous Networks
- ICI** Inter-Cell Interference
- ICIC** Inter-Cell Interference Coordination
- ICM** Interference Covariance Matrix
- IDFT** Inverse Discrete Fourier Transform
- IEEE** Institute of Electrical and Electronics Engineers
- IFFT** Inverse Fast Fourier Transform
- IMT-A** International Mobile Telecommunications-Advanced
- IP** Internet Protocol
- IRC** Interference Rejection Combining
- ISI** Inter-Symbol Interference
- ITU** International Telecommunications Union
- JTRS** Joint Tactical Radio Systems
- KPI** Key Performance Indicator
- LA** Link Adaptation
- LAN** Local Area Network

-
- LANs** Local Area Networks
- LC** Linear Combining
- LDPC** Low Density Parity Check
- LOS** Line of Sight
- LS** Least-Square
- LTE** Long Term Evolution
- LTE-A** Long Term Evolution - Advanced
- MAC** Medium Access Control
- MANET** Mobile Ad-hoc NETWORKS
- MC** Multi-Carrier
- MC-CDMA** Multi-Carrier Code Division Multiple Access
- MCS** Modulation and Coding Scheme
- MIMO** Multiple Input Multiple Output
- MISO** Multiple Input Single Output
- ML** Maximum Likelihood
- MMSE** Minimum Mean Square Error
- MR** Max Rate
- MRC** Maximal Ratio Combining
- MS** Mobile Station
- MU** Multi User
- MU-MIMO** Multi User Multiple Input Multiple Output
- MUI** Multiuser Interference
- NIC** Network Interface Controller
- NLOS** Non-Line of Sight
- NSN** Nokia Solutions and Networks
- NTP** Network Time Protocol
- OAI** OpenAirInterface
- OC** Orthogonal Combining

- OFDM** Orthogonal Frequency Division Multiplexing
- OFDMA** Orthogonal Frequency Division Multiple Access
- OLLA** Outer-Loop Link Adaptation
- ORC** Orthogonality Restoring Combining
- OS** Operating System
- OSG** Open Subscriber Group
- OSSIE** Open Source SCA Implementation Embedded
- PAPR** Peak to Average Power Ratio
- PC** Power Control
- PDF** Probability Distribution Function
- PER** Packet Error Rate
- PHY** Physical Layer
- PL** path loss
- PMI** Precoding Matrix Indicator
- PRB** Physical Resource Block
- ppm** parts-per-million
- P/S** Parallel to Serial
- PS** Packet Scheduling
- PSD** Power Spectral Density
- PSK** Phase Shift Keying
- QAM** Quadrature Amplitude Modulation
- QoS** Quality of Service
- QPSK** Quadrature Phase Shift Keying
- RA** Resource Allocation
- RACH** Random Access Channel
- RAT** Radio Access Technology
- REM** Radio Environment Maps
- RF** Radio Frequency

RI	Rank Indication
RMS	Root Mean Square
RR	Round Robin
RRAT	Radio Resources Allocation Table
RRM	Radio Resource Management
RSRP	Reference Signal Signal Power
RSS	Received Signal Strength
RSSI	Received Signal Strength Indicator
RTT	Round Trip Time
RX	Receiver
SC	Selection Combining
SCA	Software Communications Architecture
SCC	Supplementary Component Carrier
SC-FDMA	Single-carrier Frequency Division Multiple Access
SC-FDM	Single-carrier Frequency Division Multiplexing
SCH	Subcarrier hopping
SDR	Software Defined Radio
SDMA	Space Division Multiple Access
SIC	Successive Interference Cancellation
SIF	Soft Interference Cancellation
SIR	Signal to Interference Ratio
SIMO	Single Input Multiple Output
SINR	Signal to Interference plus Noise Ratio
SISO	Single Input Single Output
SNR	Signal to Noise Ratio
S/P	Serial to Parallel
SSH	Secure SHell
SUT	system under test

- TCP** Transmission Control Protocol
- TCXO** Temperature Compensated Christal Oscillator
- TXCO** Temperature Compensated Christal Oscillator
- TD** Transmit Diversity
- TDD** Time Division Duplexing
- TDM** Time Division Multiplexing
- TDM-OFDMA** Time Division Multiplexed - Orthogonal Frequency Division Multiple Access
- TDMA** Time Division Multiple Access
- TDS** Time Domain Scheduling
- TX** Transmitter
- UE** User Equipment
- UHD** Universal Hardware Driver
- UL** Uplink
- USRP** Universal Software Radio Peripheral
- VPN** Virtual Private Networks
- W-OFDM** Wideband Orthogonal Frequency Division Multiplexing
- WAN** Wide Area Network
- WARP** Wireless open-Access Research Platform
- WiMAX** Worldwide Interoperability for Microwave Access
- WLAN** Wireless Local Area Network
- WMAN** Wireless Metropolitan Area Network
- WMN** Wireless Multi-Hop Networks
- WSN** Wireless Sensor Networks
- XML** eXtensive Markup Language

Bibliography

- [1] E. Hossain, M. Rasti, H. Tabassum, and A. Abdelnasser, “Evolution toward 5g multi-tier cellular wireless networks: An interference management perspective,” *Wireless Communications, IEEE*, vol. 21, pp. 118–127, June 2014.
- [2] P. Mogensen, K. Pajukoski, B. Raaf, E. Tiirola, L. Eva, I. Kovacs, G. Berardinelli, L. Garcia, L. Hu, and A. Cattoni, *B4G local area: high level requirements and system design*. IEEE Press, 2012.
- [3] S. Haykin, “Cognitive radio: brain-empowered wireless communications,” *Selected Areas in Communications, IEEE Journal on*, vol. 23, pp. 201–220, Feb 2005.
- [4] I. Akyildiz, W.-Y. Lee, M. C. Vuran, and S. Mohanty, “A survey on spectrum management in cognitive radio networks,” *Communications Magazine, IEEE*, vol. 46, pp. 40–48, April 2008.
- [5] A. He, K. K. Bae, T. Newman, J. Gaeddert, K. Kim, R. Menon, L. Morales-Tirado, J. Neel, Y. Zhao, J. Reed, and W. Tranter, “A survey of artificial intelligence for cognitive radios,” *Vehicular Technology, IEEE Transactions on*, vol. 59, pp. 1578–1592, May 2010.
- [6] P. Pawelczak, K. Nolan, L. Doyle, S. W. Oh, and D. Cabric, “Cognitive radio: Ten years of experimentation and development,” *Communications Magazine, IEEE*, vol. 49, pp. 90–100, March 2011.
- [7] R. Valenzuela, “Fundamental limits and evolution of broadband wireless access networks,” *2005 Texas Wireless Symposium, Austin*, 2005.
- [8] O. Tonelli, G. Berardinelli, F. M. L. Tavares, A. F. Cattoni, P. Popovski, T. B. Sørensen, and P. E. Mogensen, *Real-World Experimentation of Distributed DSA Network Algorithms*, pp. 171–197. IGI Global, 2013. ID: 77688.

- [9] O. Tonelli, G. Berardinelli, A. Cattoni, T. Sørensen, and P. Mogensen, “Software architecture design for a dynamic spectrum allocation-enabled cognitive radio testbed,” *Proceedings of the European Signal Processing Conference (EUSIPCO)*, 2011.
- [10] G. Berardinelli, P. Zetterberg, O. Tonelli, A. Cattoni, T. Sørensen, and P. Mogensen, “An sdr architecture for ofdm transmission over usrp2 boards,” 2011.
- [11] A. Cattoni, J. Buthler, O. Tonelli, L. Da Silva, J. Cruz Lopez Miranda, P. Sutton, F. Crespi, S. Benco, A. Perotti, and D. Riviello, *Designing a CR Test bed - Practical Issues*. Springer-VS, 2014.
- [12] O. Tonelli, I. Rodriguez, G. Berardinelli, A. Cattoni, J. Buthler, T. Sørensen, and P. Mogensen, *Validation of an Inter-Cell Interference Coordination Solution in Real-World Deployment Conditions*. IEEE VTS Vehicular Technology Conference. Proceedings, 2014.
- [13] O. Tonelli, G. Berardinelli, F. Tavares, A. Cattoni, I. Kovacs, T. Sørensen, P. Popovski, and P. Mogensen, *Experimental validation of a distributed algorithm for dynamic spectrum access in local area networks*, pp. 1–5. IEEE, 2013.
- [14] G. Berardinelli, F. Tavares, N. Mahmood, O. Tonelli, A. Cattoni, T. Sørensen, and P. Mogensen, *Distributed synchronization for Beyond 4G Indoor Femtocells*, pp. 1–5. International Conference on Telecommunications, IEEE, 2013.
- [15] G. Berardinelli, J. Buthler, F. Tavares, O. Tonelli, D. Assefa, F. Hakhmaneshi, T. Sørensen, and P. Mogensen, “Distributed synchronization of a testbed network with usrp n200 radio boards,” *Asilomar Conference on Signals, Systems and Computers. Conference Record*, 2014.
- [16] S. Ivanov, A. Herms, and G. Lukas, “Experimental validation of the ns-2 wireless model using simulation, emulation, and real network,” in *Communication in Distributed Systems (KiVS), 2007 ITG-GI Conference*, pp. 1–12, Feb 2007.
- [17] “The network simulator - ns-2.” <http://www.isi.edu/nsnam/ns/>, February 2014.
- [18] J. Liu, Y. Yuan, D. M. Nicol, R. S. Gray, C. C. Newport, D. Kotz, and L. F. Perrone, “Empirical validation of wireless models in simulations of ad hoc routing protocols,” *Simulation*, vol. 81, pp. 307–323, Apr. 2005.
- [19] K. Tan, D. Wu, A. J. Chan, and P. Mohapatra, “Comparing simulation tools and experimental testbeds for wireless mesh networks,” *Pervasive and Mobile Computing*, vol. 7, no. 4, pp. 434 – 448, 2011.

- [20] A. Kashyap, S. Ganguly, and S. R. Das, "Measurement-based approaches for accurate simulation of 802.11-based wireless networks," in *Proceedings of the 11th International Symposium on Modeling, Analysis and Simulation of Wireless and Mobile Systems*, MSWiM '08, (New York, NY, USA), pp. 54–59, ACM, 2008.
- [21] M. Al-Bado, R. Merz, C. Sengul, and A. Feldmann, "A site-specific indoor link model for realistic wireless network simulations," in *Proceedings of the 4th International ICST Conference on Simulation Tools and Techniques*, SIMU-Tools '11, (ICST, Brussels, Belgium, Belgium), pp. 178–187, ICST (Institute for Computer Sciences, Social-Informatics and Telecommunications Engineering), 2011.
- [22] M. Al-Bado, C. Sengul, and R. Merz, "What details are needed for wireless simulations? - a study of a site-specific indoor wireless model," in *INFOCOM, 2012 Proceedings IEEE*, pp. 289–297, March 2012.
- [23] D. Raychaudhuri, I. Seskar, M. Ott, S. Ganu, K. Ramachandran, H. Kremo, R. Siracusa, H. Liu, and M. Singh, "Overview of the orbit radio grid testbed for evaluation of next-generation wireless network protocols," in *Wireless Communications and Networking Conference, 2005 IEEE*, vol. 3, pp. 1664–1669 Vol. 3, March 2005.
- [24] Y.-D. Lin, S.-L. Tsao, S.-L. Chang, S.-Y. Cheng, and C.-Y. Ku, "Design issues and experimental studies of wireless lan mesh," *Wireless Communications, IEEE*, vol. 17, pp. 32–40, April 2010.
- [25] K. Nolan, P. Sutton, L. Doyle, T. Rondeau, B. Le, and C. Bostian, "Dynamic spectrum access and coexistence experiences involving two independently developed cognitive radio testbeds," in *New Frontiers in Dynamic Spectrum Access Networks, 2007. DySPAN 2007. 2nd IEEE International Symposium on*, pp. 270–275, April 2007.
- [26] E. Meshkova, J. Ansari, D. Denkovski, J. Riihijarvi, J. Nasreddine, M. Pavloski, L. Gavrilovska, and P. Mahonen, "Experimental spectrum sensor testbed for constructing indoor radio environmental maps," in *New Frontiers in Dynamic Spectrum Access Networks (DySPAN), 2011 IEEE Symposium on*, pp. 603–607, May 2011.
- [27] E. Meshkova, J. Ansari, J. Riihijarvi, J. Nasreddine, and P. Mahonen, "Estimating transmitter activity patterns: An empirical study in the indoor environment," in *Personal Indoor and Mobile Radio Communications (PIMRC), 2011 IEEE 22nd International Symposium on*, pp. 503–508, Sept 2011.
- [28] E. Meshkova, J. Riihijarvi, J. Ansari, and P. Mähönen, "Indoor coverage estimation from unreliable measurements using spatial statistics," in *Proceedings of the 16th ACM International Conference on Modeling, Analysis & Simulation of Wireless and Mobile Systems*, MSWiM '13, (New York, NY, USA), pp. 211–218, ACM, 2013.

- [29] J. Lei, R. Yates, L. Greenstein, and H. Liu, "Wireless link snr mapping onto an indoor testbed," in *Testbeds and Research Infrastructures for the Development of Networks and Communities, 2005. Tridentcom 2005. First International Conference on*, pp. 130–135, Feb 2005.
- [30] T.-T. Luong, V. Subbaraju, A. Misra, and S. Seshan, "Measurement-driven performance analysis of indoor femtocellular networks," in *Proceedings of the Seventh ACM International Workshop on Wireless Network Testbeds, Experimental Evaluation and Characterization, WiNTECH '12*, (New York, NY, USA), pp. 19–26, ACM, 2012.
- [31] M. Y. Arslan, J. Yoon, K. Sundaresan, S. V. Krishnamurthy, and S. Banerjee, "Fermi: A femtocell resource management system for interference mitigation in ofdma networks," in *Proceedings of the 17th Annual International Conference on Mobile Computing and Networking, MobiCom '11*, (New York, NY, USA), pp. 25–36, ACM, 2011.
- [32] J. Yoon, M. Y. Arslan, K. Sundaresan, S. V. Krishnamurthy, and S. Banerjee, "A distributed resource management framework for interference mitigation in ofdma femtocell networks," in *Proceedings of the Thirteenth ACM International Symposium on Mobile Ad Hoc Networking and Computing, MobiHoc '12*, (New York, NY, USA), pp. 233–242, ACM, 2012.
- [33] J. Mitola and J. Maguire, G.Q., "Cognitive radio: making software radios more personal," *Personal Communications, IEEE*, vol. 6, pp. 13–18, Aug 1999.
- [34] T. Yucek and H. Arslan, "A survey of spectrum sensing algorithms for cognitive radio applications," *Communications Surveys Tutorials, IEEE*, vol. 11, pp. 116–130, First 2009.
- [35] "a survey on {MAC} protocols for cognitive radio networks ", " *Ad Hoc Networks* ", vol. "7", no. "7".
- [36] A. Tkachenko, D. Cabric, and R. Brodersen, "Cyclostationary feature detector experiments using reconfigurable bee2," in *New Frontiers in Dynamic Spectrum Access Networks, 2007. DySPAN 2007. 2nd IEEE International Symposium on*, pp. 216–219, April 2007.
- [37] T. Akram, T. Esemann, T. Teubler, and H. Hellbrück, "A reusable and extendable testbed for implementation and evaluation of cooperative sensing," in *Proceedings of the 8th ACM Workshop on Performance Monitoring and Measurement of Heterogeneous Wireless and Wired Networks, PM2HW2N '13*, (New York, NY, USA), pp. 45–52, ACM, 2013.
- [38] C. Sokolowski, M. Petrova, A. De Baynast, and P. Mahonen, "Cognitive radio testbed: Exploiting limited feedback in tomorrow's wireless communication networks," in *Communications Workshops, 2008. ICC Workshops '08. IEEE International Conference on*, pp. 493–498, May 2008.

- [39] P. Sutton, K. Nolan, and L. Doyle, "Cyclostationary signatures in practical cognitive radio applications," *Selected Areas in Communications, IEEE Journal on*, vol. 26, pp. 13–24, Jan 2008.
- [40] P. De, A. Raniwala, S. Sharma, and T. cker Chiueh, "Design considerations for a multihop wireless network testbed," *Communications Magazine, IEEE*, vol. 43, pp. 102–109, Oct 2005.
- [41] S. Sengupta, K. Hong, R. Chandramouli, and K. P. Subbalakshmi, "Spider-radio: A cognitive radio network with commodity hardware and open source software," *Communications Magazine, IEEE*, vol. 49, pp. 101–109, March 2011.
- [42] "The madwifi project." <http://madwifi-project.org>, February 2014.
- [43] K. Chowdhury and T. Melodia, "Platforms and testbeds for experimental evaluation of cognitive ad hoc networks," *Communications Magazine, IEEE*, vol. 48, pp. 96–104, Sept 2010.
- [44] "The univeral software radio peripheral." <http://www.ettus.com/>, February 2014.
- [45] T. Newman, S. Shajedul Hasan, D. DePoy, T. Bose, and J. Reed, "Designing and deploying a building-wide cognitive radio network testbed," *Communications Magazine, IEEE*, vol. 48, pp. 106–112, Sept 2010.
- [46] "Gnu radio - the free and open-source software radio ecosystem." <http://www.gnuradio.org/>, March 2014.
- [47] Z. Yan, Z. Ma, H. Cao, G. Li, and W. Wang, "Spectrum sensing, access and coexistence testbed for cognitive radio using usrp," in *Circuits and Systems for Communications, 2008. ICCSC 2008. 4th IEEE International Conference on*, pp. 270–274, May 2008.
- [48] K. Amiri, J. Cavallaro, C. Dick, and R. Rao, "A high throughput configurable sdr detector for multi-user mimo wireless systems," *Journal of Signal Processing Systems*, vol. 62, no. 2, pp. 233–245, 2011.
- [49] E. Everett, M. Duarte, C. Dick, and A. Sabharwal, "Empowering full-duplex wireless communication by exploiting directional diversity," in *Signals, Systems and Computers (ASILOMAR), 2011 Conference Record of the Forty Fifth Asilomar Conference on*, pp. 2002–2006, Nov 2011.
- [50] C. Chang, J. Wawrzynek, and R. W. Brodersen, "Bee2: A high-end reconfigurable computing system," *IEEE Design And Test of Computers*, vol. 22, no. 2, pp. 114–125, 2005.
- [51] K. Tan, H. Liu, J. Zhang, Y. Zhang, J. Fang, and G. M. Voelker, "Sora: High-performance software radio using general-purpose multi-core processors," *Commun. ACM*, vol. 54, pp. 99–107, Jan. 2011.

- [52] F. Kaltenberger, R. Ghaffar, R. Knopp, H. Anouar, and C. Bonnet, "Design and implementation of a single-frequency mesh network using openairinterface," *EURASIP J. Wirel. Commun. Netw.*, vol. 2010, pp. 19:1–19:12, Apr. 2010.
- [53] D. Finn, J. C. Tallon, L. A. DaSilva, P. Van Wesemael, S. Pollin, W. Liu, S. Bouckaert, J. Vanhie-Van Gerwen, N. Michailow, J. Hauer, D. Willkomm, and C. Heller, "Experimental assessment of tradeoffs among spectrum sensing platforms," in *Proceedings of the 6th ACM International Workshop on Wireless Network Testbeds, Experimental Evaluation and Characterization*, WiNTECH '11, (New York, NY, USA), pp. 67–74, ACM, 2011.
- [54] T. Schmid, O. Sekkat, and M. B. Srivastava, "An experimental study of network performance impact of increased latency in software defined radios," in *Proceedings of the Second ACM International Workshop on Wireless Network Testbeds, Experimental Evaluation and Characterization*, WinTECH '07, (New York, NY, USA), pp. 59–66, ACM, 2007.
- [55] G. Nychis, T. Hottelier, Z. Yang, S. Seshan, and P. Steenkiste, "Enabling mac protocol implementations on software-defined radios," in *Proceedings of the 6th USENIX Symposium on Networked Systems Design and Implementation*, NSDI'09, (Berkeley, CA, USA), pp. 91–105, USENIX Association, 2009.
- [56] A. Sanchez, I. Moerman, S. Bouckaert, D. Willkomm, J. Hauer, N. Michailow, G. Fettweis, L. Dasilva, J. Tallon, and S. Pollin, "Testbed federation: An approach for experimentation-driven research in cognitive radios and cognitive networking," in *Future Network Mobile Summit (FutureNetw), 2011*, pp. 1–9, June 2011.
- [57] C. Gonzalez, C. Dietrich, S. Sayed, H. Volos, J. Gaeddert, P. Robert, J. Reed, and F. Kragh, "Open-source sca-based core framework and rapid development tools enable software-defined radio education and research," *Communications Magazine, IEEE*, vol. 47, pp. 48–55, October 2009.
- [58] P. Sutton, J. Lotze, H. Lahlou, S. Fahmy, K. Nolan, B. Ozgul, T. Rondeau, J. Noguera, and L. Doyle, "Iris: an architecture for cognitive radio networking testbeds," *Communications Magazine, IEEE*, vol. 48, pp. 114–122, Sept 2010.
- [59] D. R. Musser and A. Saini, *The STL Tutorial and Reference Guide: C++ Programming with the Standard Template Library*. Redwood City, CA, USA: Addison Wesley Longman Publishing Co., Inc., 1995.
- [60] A. Williams, *C++ concurrency in action: practical multithreading*. Shelter Island, NY: Manning Publ., 2012.
- [61] E. W. Dijkstra, "Solution of a problem in concurrent programming control," *Commun. ACM*, vol. 8, pp. 569–, Sept. 1965.

- [62] D. Finn, J. Tallon, L. DaSilva, J. V. V. Gerwen, S. Bouckaert, I. Moerman, C. Heller, A. Sanchez, S. Pollin, P. VanWesemael, J. Hauer, D. Willkomm, and N. Michailow, "Project deliverable d2.2 definition of the federation," tech. rep., EC FP7, Mar. 2011.
- [63] P. Mogensen, W. Na, I. Kovacs, F. Frederiksen, A. Pokhariyal, K. Pedersen, T. Kolding, K. Hugl, and M. Kuusela, "Lte capacity compared to the shannon bound," in *Vehicular Technology Conference, 2007. VTC2007-Spring. IEEE 65th*, pp. 1234–1238, April 2007.
- [64] Alcatel-Lucent, picoChip Designs, Vodafone, "Simulation assumptions and parameters for fdd henb rf requirements," *3GPP T-doc R4-092042*, May 2009.
- [65] P. Kyösti, J. Meinilä, L. Hentilä, X. Zhao, T. Jämsä, C. Schneider, M. Narandzić, M. Milojević, A. Hong, J. Ylitalo, V.-M. Holappa, M. Alatossava, R. Bultitude, Y. de Jong, and T. Rautiainen, "WINNER II Channel Models," tech. rep., EC FP6, Sept. 2007.
- [66] K. Sung, H. Haas, and S. McLaughlin, "A semianalytical pdf of downlink sinr for femtocell networks," *EURASIP Journal on Wireless Communications and Networking*, vol. 2010, no. 1, p. 256370, 2010.
- [67] F. Capozzi, G. Piro, L. Grieco, G. Boggia, and P. Camarda, "On accurate simulations of lte femtocells using an open source simulator," *EURASIP Journal on Wireless Communications and Networking*, vol. 2012, no. 1, p. 328, 2012.
- [68] G. Da Costa, *Dynamic Spectrum Sharing among Femtocells: Coping with Spectrum Scarcity in 4G and Beyond*. PhD thesis, 2012.
- [69] S. Szyszkowicz, H. Yanikomeroğlu, and J. Thompson, "On the feasibility of wireless shadowing correlation models," *Vehicular Technology, IEEE Transactions on*, vol. 59, pp. 4222–4236, Nov 2010.
- [70] W. Nam, D. Bai, J. Lee, and I. Kang, "Advanced interference management for 5g cellular networks," *Communications Magazine, IEEE*, vol. 52, pp. 52–60, May 2014.
- [71] L. Garcia, *Autonomous Component Carrier Selection for 4G Femtocells*. PhD thesis, 2011.
- [72] L. Garcia, K. Pedersen, and P. Mogensen, "Autonomous component carrier selection: interference management in local area environments for lte-advanced," *IEEE Communications Magazine*, vol. 47, no. 9, pp. 110–116, 2009.
- [73] Nokia Siemens Networks, Nokia, "Inter enb over-the-air communication (otac) for lte-advanced," *3GPP T-doc R1-092036*, January 2009.

- [74] L. Garcia, K. Pedersen, and P. Mogensen, *Autonomous Component Carrier Selection for Local Area Uncoordinated Deployment of LTE-Advanced*. IEEE, 2009.
- [75] Nokia Siemens Networks, Nokia, “Use of background interference matrix for autonomous component carrier selection for lte-a,” *3GPP T-doc R1-090736*, February 2009.
- [76] F. Sanchez-Moya, J. Villalba-Espinosa, L. Garcia, K. Pedersen, and P. Mogensen, “On the impact of explicit uplink information on autonomous component carrier selection for lte-a femtocells,” *IEEE VTS Vehicular Technology Conference. Proceedings*, 2011.
- [77] “Samurai: Spectrum aggregation and multi-user mimo: Real-world impact.” <http://www.ict-samurai.eu/>, September 2014.
- [78] L. Garcia, I. Kovacs, K. Pedersen, G. Da Costa, and P. Mogensen, “Autonomous component carrier selection for 4g femtocells: A fresh look at an old problem,” *IEEE Journal on Selected Areas in Communications*, vol. 30, no. 3, pp. 525 – 537, 2012.
- [79] M. Lampinen, F. Del Carpio, T. Kuosmanen, T. Koivisto, and M. Enescu, “System-level modeling and evaluation of interference suppression receivers in lte system,” in *Vehicular Technology Conference (VTC Spring), 2012 IEEE 75th*, pp. 1–5, May 2012.
- [80] F. Tavares, G. Berardinelli, N. Mahmood, T. Sørensen, and P. Mogensen, *On the Potential of Interference Rejection Combining in B4G Networks*, pp. 1–5. IEEE VTS Vehicular Technology Conference. Proceedings, IEEE, 2013.
- [81] P. Mogensen, K. Pajukoski, E. Tiirola, and E. L. *5G small cell optimized radio design*. IEEE.
- [82] “National instruments - usrp.” <http://www.ni.com/usrp/applications/>, September 2014.
- [83] A. Osseiran, K. Zangi, D. Hui, and L. Krasny, “Interference mitigation for mimo systems employing user-specific, linear precoding,” in *Personal, Indoor and Mobile Radio Communications, 2008. PIMRC 2008. IEEE 19th International Symposium on*, pp. 1–6, Sept 2008.
- [84] C. Shannon, “A mathematical theory of communication,” *Bell System Technical Journal*, vol. 27, pp. 379–423, 623–656, July, October 1948.
- [85] B. Popovic, “Generalized chirp-like polyphase sequences with optimum correlation properties,” *Information Theory, IEEE Transactions on*, vol. 38, pp. 1406–1409, Jul 1992.