



Aalborg Universitet

AALBORG UNIVERSITY
DENMARK

Wave Pressures and Loads on a Small Scale Model of the Svåheia SSG Pilot Project

Buccino, Mariano; Vicinanza, Diego; Ciardulli, Francesco; Calabrese, Mario; Kofoed, Jens Peter

Published in:
9th ewtec 2011

Publication date:
2011

Document Version
Publisher's PDF, also known as Version of record

[Link to publication from Aalborg University](#)

Citation for published version (APA):
Buccino, M., Vicinanza, D., Ciardulli, F., Calabrese, M., & Kofoed, J. P. (2011). Wave Pressures and Loads on a Small Scale Model of the Svåheia SSG Pilot Project. In A. S. Bahaj (Ed.), 9th ewtec 2011 : Proceedings of the 9th European Wave and Tidal Conference, Southampton, UK, 5th-9th September 2011 University of Southampton.

General rights

Copyright and moral rights for the publications made accessible in the public portal are retained by the authors and/or other copyright owners and it is a condition of accessing publications that users recognise and abide by the legal requirements associated with these rights.

- ? Users may download and print one copy of any publication from the public portal for the purpose of private study or research.
- ? You may not further distribute the material or use it for any profit-making activity or commercial gain
- ? You may freely distribute the URL identifying the publication in the public portal ?

Take down policy

If you believe that this document breaches copyright please contact us at vbn@aub.aau.dk providing details, and we will remove access to the work immediately and investigate your claim.

Wave Pressures and Loads on a Small Scale Model of the Svåheia SSG pilot project

Mariano Buccino^{#1}, Diego Vicinanza^{*2}, Francesco Ciardulli^{#3} Mario Calabrese^{#4} Jens Peter Kofoed^{°5}

[#]*Department of Hydraulic, Geotechnical and Environmental Engineering, University of Naples Federico II.*

Via Claudio 21, Naples, ITALY

¹buccino@unina.it

³francesco.ciardulli@unina.it

⁴calabres@unina.it

^{*}*Department of Civil Engineering, Seconda Università di Napoli.*

Via Roma 29, 81031, Aversa (CE), ITALY

²diegovic@unina.it

[°]*Department of Civil Engineering, Aalborg University.*

Sohngaardsholmsvej 57, DK-9000, Aalborg, DENMARK

⁵jpk@civil.aau.dk

Abstract— The paper reports on 2D small scale experiments conducted to investigate wave loadings acting on a pilot project of device for the conversion of wave energy into electricity. The conversion concept is based on the overtopping principle and the structure is worldwide known with the acronym SSG. The hydraulic model tests have been carried out at the LInC laboratory of the University of Naples Federico II using random waves. Results indicate wave overtopping is able to cause a sudden inversion of vertical force under wave crest, so that it is alternatively upward and downward directed over a short time interval. It is also shown that two calculation methods widely employed in the Japanese design practice of vertical face breakwaters, could be used to achieve safe estimates of the hydrodynamic loadings

Keywords— Ovetopping device, Wave Forces, Hydraulic modelling, Japanese design practice, Collapsing breakers

I. INTRODUCTION

WAVEenergy AS company (Stavanger, Norway) was founded in April 2004 to develop the *Seawave Slot-cone Generator* (SSG) concept. The SSG is a Wave Energy Converter utilizing a total of three reservoirs placed on top of each other, in which the energy of the incoming wave will be stored as potential energy (Fig. 1).

The water captured in the reservoirs then will run through turbines for electricity production. The device utilize a wide spectra of different wave conditions by means of multiple reservoirs located at different levels above the still water level, and thereby obtains a high overall efficiency and it can be suitable for shoreline and breakwater applications, presenting particular advantages such as: sharing structure costs, availability of grid connection and infrastructures, recirculation of water inside the harbour as the outlet of the turbines is on the rear part of the device.



Fig.1. Artistic representation of one 3-level SSG with multistage turbine.

Recently, plans for SSG pilot installation were in progress at the Svåheia site (Norway), Port of Hanstholm (Denmark) and Port of Garibaldi (Oregon, USA). In the latter two projects the Sea-wave Slot-cone Generator technology is integrated into outer harbour breakwater and jetty reconstruction projects.

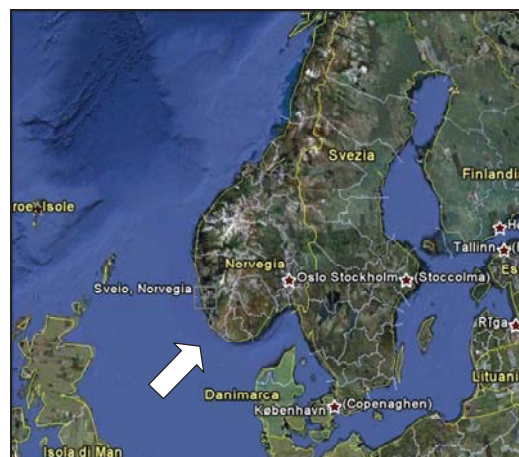

Fig.2. Location of the new pilot plant

Unlike traditional harbor defenses, WEC devices need by nature to be exposed to large wave forces and are generally designed to face and challenge the sea as much as possible. The design criteria of traditional maritime structures may be not satisfactory for designing innovative breakwater as SSGs.

This paper reports results of small scale random wave experiments conducted to investigate the intensity and the dynamic properties of the actions induced by the waves on a SSG located on a steep foreshore. The experiments were thought to serve as a guidance for the structural design of a pilot project to be built in Svåheia (Stavanger, Norway, Fig.2).

Laboratory tests were carried out at the University of Naples "Federico II" as a part of the project PRIST 2007 (Progetti di Ricerca di Rilevante Interesse Scientifico e Tecnologico) funded by the Second University of Naples and coordinated by D.Vicinanza.

II. EXPERIMENTAL WORK

A. Description of Test Facility and Model

The experiments have been conducted at the small scale channel (SSC) of the Department of Hydraulic, Geotechnical and Environmental Engineering (DIGA) of the University of Naples "Federico II". The flume is 22m long, 0.5m wide and 0.75m height and is equipped with a piston type wave-maker, capable of generating both periodic and random wave series. The facility is also provided with an active absorption system that lowers any undesired reflection effects.

The SSG to be tested was scaled down at a 66 length ratio; together with the device, also the steeper part of the foreshore (nearly 93m far from the SSG) was re-constructed in the flume, using the same scale (Fig. 3). The model was entirely made of plexiglass. The submerged beach included a 1:5 approaching slope followed by a double ramp with an inclination of 1:1 and 1:2.5 respectively. Then a flat floor allowed the placement of the structure, which was 0.48m wide (Fig. 4). The water depth was fixed at 0.5m, corresponding to 33m at prototype scale

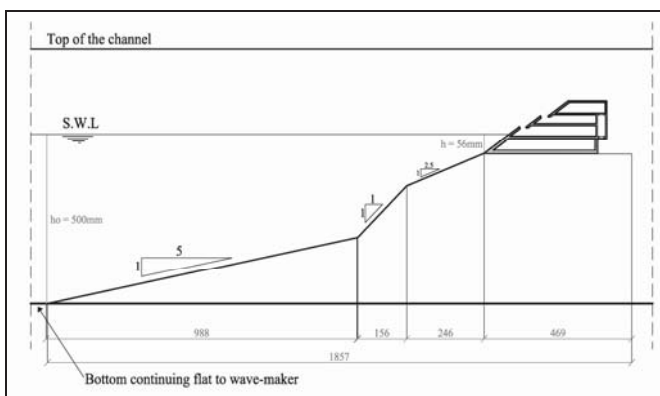

Fig.3. Sketch of the tested model. Dimensions in mm at model scale

It is worth noticing that in the model the sea bottom was kept flat offshore the 1:5 beach, whereas in Svåheia it actually slopes down up to 70m at an average rate of 0.09.

B. Design Storms

After a long term analysis of the wave climate at the site of location of the pilot plant, five sea states driven by a mean JONSWAP spectrum (shape parameter 3.3) were selected as design storms to be run. Wave parameters, significant wave height (H_s) and peak period (T_p) are reported in Table I. The scaling from prototype to model has been done using the Froude criterion. Design storm conditions approximately correspond to a 50 years return period.

Each test had a 2000 wave duration (nearly 3000s); this ensures loadings with a low exceedance probability to be estimated on a sample sufficiently wide.

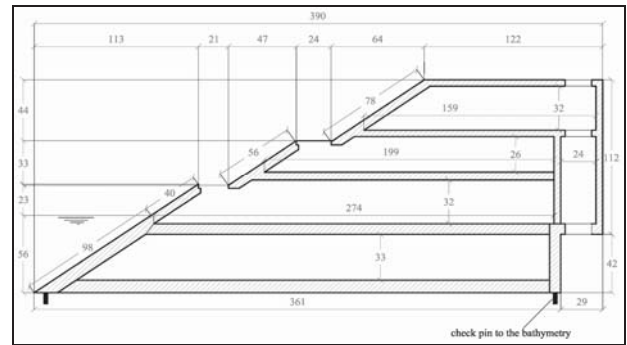

Fig.4. Cross section of the SSG. Dimensions in mm at model scale

TABLE I
DESIGN STORM CONDITIONS

Test code	Prototype		Model	
	H_s (m)	T_p (s)	H_s (m)	T_p (s)
TEST 1	9	15.1	0.137	1.86
TEST 2	9.5	15.4	0.144	1.90
TEST 3	10	15.9	0.151	1.96
TEST 4	10.5	15.9	0.159	1.96
TEST 5	11	15.9	0.167	1.96

C. Control of the inshore water level

Preliminary tests revealed the SSG to experience violent overtopping during the design storms. Hence, due to the relevant length of the experiments, a significant amount of water tends to accumulate rear the model, leading to an unrealistic setup of the mean sea level. The latter induces an artificial increase of pressure at the back of the device that pushes the latter seaward. To compensate this model effect, a recirculation system was designed. A reservoir, placed 4.00m off the trailing edge of the structure, collected the overtopped water, which was conveyed to the rear of the wave-maker by means of an electric pump. In the space between the rear of the model and the reservoir, a mound made of cobblestones was built, in order to both absorbing the wave reflection and lowering the water fluctuation above the outer plate of the reservoir (Fig. 5).

D. Instrumentation

The oscillations of free surface have been recorded by four twin-wire resistive probes sampled at 100Hz. Three of them

were placed on the flat bottom, prior the 1:5 slope, to resolve wave reflection; a fourth gauge have been located approximately in the middle of the 1:5 foreshore.



Fig.5. The recirculation system

For measuring wave forces, an ad hoc device has been constructed at the DIGA Department of University of Naples “Federico II” (Fig.6). The balance consisted of a measuring beam connected to three load cells (maximum load 150kg) by means of steel bounds. The cells were fixed at a rigid frame that connected the device to the side walls of the channel. The upper cell measured the vertical force, whereas the two underlying cells measured the resulting horizontal force as well as the torque in the plane of motion. During the calibration phase, the cells resulted to function properly with a standard error of about 10-2kg. An ad hoc excitation analysis has been conducted to investigate the frequency response of the system (FRF). The lowest peak of resonance has been detected at 70 Hz for the vertical loading cell. Accordingly, the device has been sampled at 100 Hz, giving a maximum frequency of analysis (Nyquist frequency) of 50Hz.

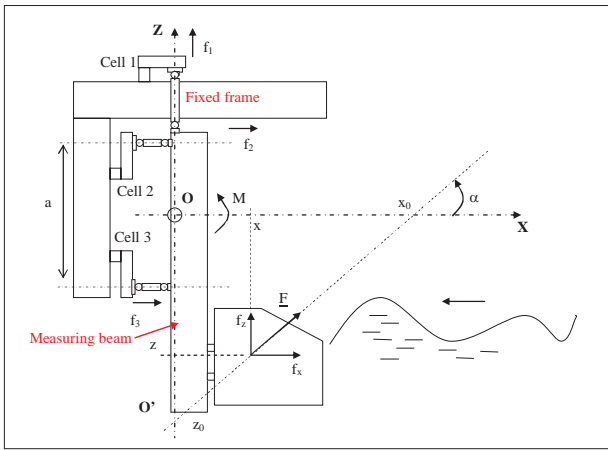

Fig.6. Schematic of the force measuring device.

For measuring wave pressures, four small sized cells, with a 18mm diameter, have been used. The latter have been moved, repeating the same wave attack, to cover 21 positions along the outer geometry of the SSG (Fig 7). To follow impact events that possibly occur at the structure front face, the cells have been sampled at 1000Hz. Wave pressures have been acquired only for TEST 3. It is worth to remark that in all

measurements the mouth of the SSG reservoir were kept closed; this to avoid an improper inflow-outflow mechanism to affect the time history of forces and pressures.

E. Data Processing

The incoming wave field at the flat floor seaward the foreshore, have been separated from the reflected by using the weighted least squared method proposed by [1].

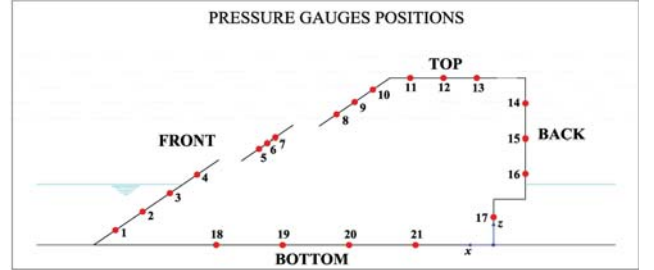

Fig.7. Scheme of pressure gauge positions

As the method essentially relies on a linear approach, the original time series have been previously cut in the frequency domain. The cut have been applied to frequencies external to the band 0.25 – 1Hz, which roughly corresponds to the interval between 0.5 – 2 times the incoming peak frequency. From this analysis the incident and reflected time series have been obtained. The latter have been further analyzed to obtain incident and reflected wave spectra. For the spectral estimation, the method proposed by [2] has been used. In the calculation a base segment of 10s has been employed, corresponding to a 0.1Hz frequency resolution. Different base segments have been overlapped at a degree of 50%. To reduce leakage effects, a standard Hanning window has been applied. With this approach incident and reflected wave spectra have been estimated for each test.

Time domain statistics of wave loads and pressures have been obtained through a zero up-crossing analysis. The latter has been conducted using the approach proposed by [3], which includes a time domain filter based on two thresholds, namely $T_{\min, v}$ and $T_{\min, d}$. If three successive zero crossing are observed over a time interval less than $T_{\min, v}$, the first two passages through zeros are eliminated; otherwise if two successive zero crossings occur over a period of time less than $T_{\min, d}$, they are both eliminated. In the present analysis the standard values 0.4 and 0.08 have been used respectively for $T_{\min, v}$ and $T_{\min, d}$.

III. RESULTS

A. Wave profile macrofeatures and load characteristics

Owing to the relevant steepness of the foreshore, waves reached the SSG structure mostly in form of well-developed surging/collapsing breakers [4]. An example is shown in Fig.8.

The sequence shows the ramps are exposed during the down-rush phase and breaking starts with a jet of fluid that detaches from the base of the wave (collapsing breaker, picture 1). The jet impinges the foreshore, giving rise to a well

visible foamy area (pict. 4 and 5). Then the wave takes the shape of a surging breaker with a bubbling toe, which climbs the structure causing a severe overtopping.

Under this most frequent situation, the horizontal momentum carried along by the incoming waves at the toe of the steep foreshore seems to transform into horizontal force at the structure following a quasi-linear path. This is shown in Figures 9a and 9b, where wave and force signals are standardized to facilitate the comparison; the inshore directed wave loads are assumed positive.

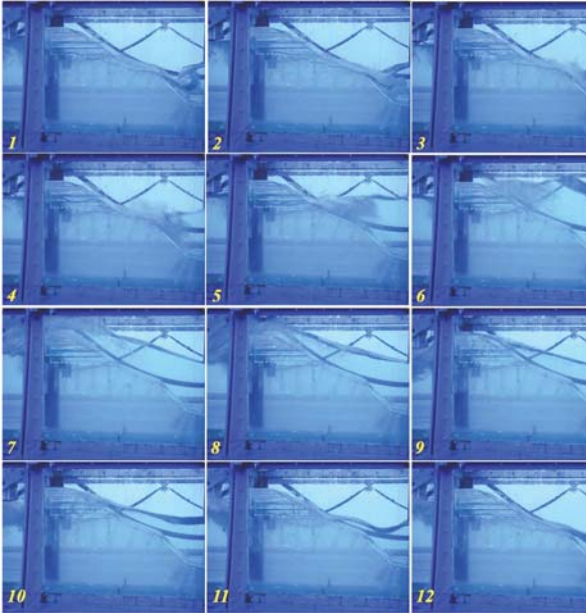

Fig.8. Example of collapsing breaker at the SSG (TEST 5)

On contrary, the vertical force signal (the force is positive upwards) is deeply non-linear and the dominant oscillation frequency moves to twice the peak frequency of the incoming waves (Fig.10a and 10b).

The reason of that is not yet clear and research work is still in progress. However this behaviour should depend on the fact that the vertical force results from the superimposition of three different components, namely the uplift at the bottom of SSG, the vertical component of the force acting onto the inclined front-face and the overtopping induced loading.

From a series of new regular wave tests conducted at the University of Naples, it would seem that these components are rather different in the frequency domain; in addition they would be significantly phase shifted and this would explain the complex shape of the resultant vertical force signal.

However, from an engineering point of view it can be concluded that maximum vertical force and maximum horizontal force are time-shifted. When the vertical force attains its maximum, which presumably corresponds to the peak of the uplift component, the horizontal force is relatively small, say half the maximum.

On contrary at the peak of the horizontal force the vertical component might be downward-directed, i.e. it may counteract the possible inshore sliding of the SSG.

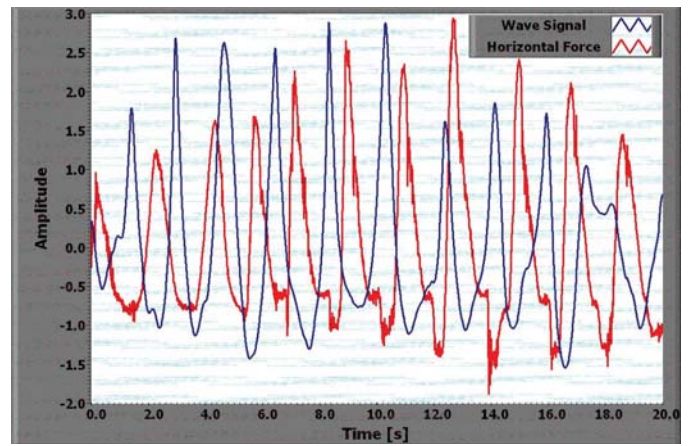

Fig.9a. Wave and force signals (standardized) for TEST 5. Time domain.

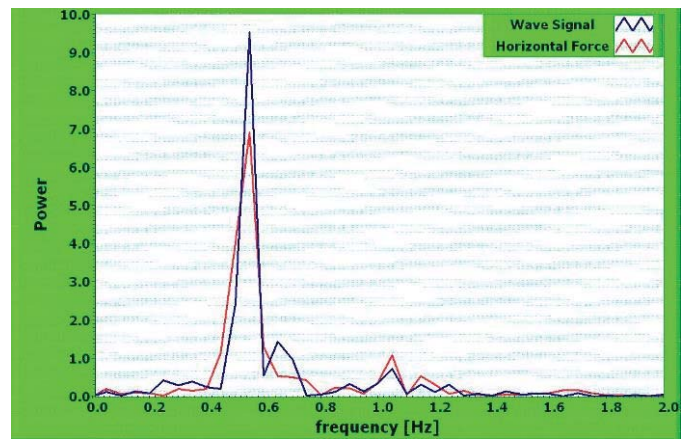

Fig.9b. Wave and force signals (standardized) for TEST 5. Frequency domain.

As a further matter of interest, Fig.10 shows a peak of the vertical force located nearly at the trough of the horizontal load signal. This corresponds to a peak of uplift pressures induced by the overtopping occurrence. Although the amplitude may seem not so severe, this situation deserves to be carefully considered in practical applications, because the pressures acting onto the inner face of the SSG during overtopping events are of impulsive nature. This is displayed in Fig.11, where the pressure signal at the still water level (transducer #3 in Fig.3), is compared to those at rear of the SSG (transd. 14 ad 15). This result seems to be consistent with findings of [5].

Finally, Fig. 12 compares the vertical force signal to the torque at the inner toe of the wall. The chronograms are perfectly in phase; that means the SSG doesn't tend to overturn under the wave crest, but slightly earlier, i.e. the overturning point does not correspond to the maximum of the horizontal force.

B. Predicting maxima of wave forces

Previous paragraph has demonstrated that wave force chronograms follow a pattern not as easy as one might expect.

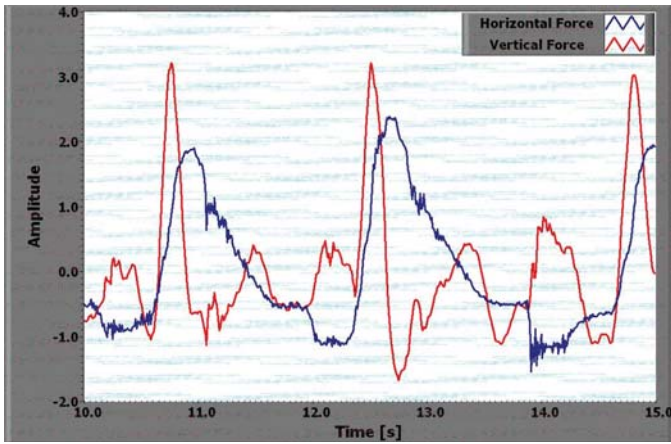

Fig. 10a. Comparison between horizontal and vertical load signals (standardized) for TEST 5. Time domain.

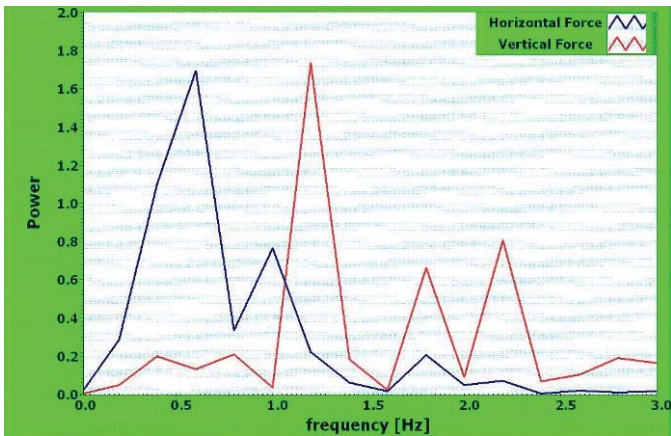
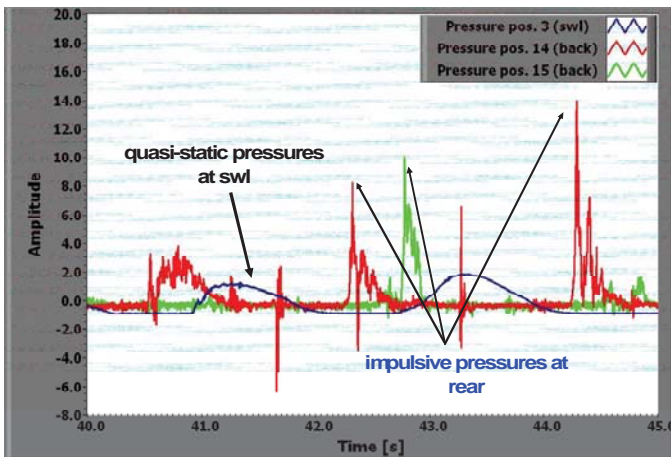

Fig. 10b. Comparison between horizontal and vertical load signals (standardized) for TEST 5. Frequency domain.



Pressure signals (standardized) at positions 3, 14 and 15.

As a consequence, much more experiments would be required to derive an optimal design criterion.

However, a first tentative approach might be to apply the formulae of Japanese design practice for vertical-face breakwaters (Fig. 13).

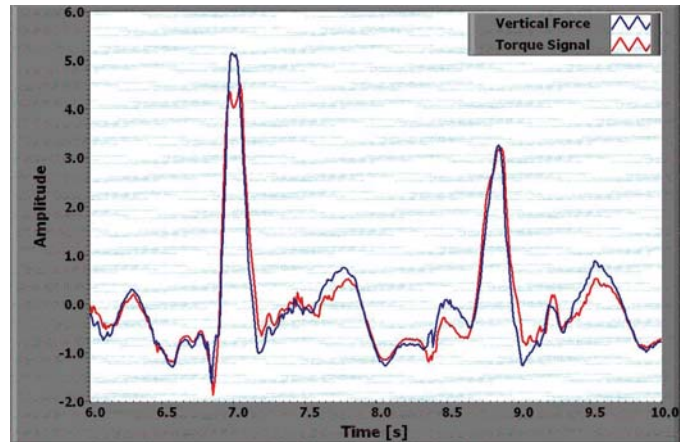

Fig. 12. Vertical force signal vs. torque (standardized). TEST 5

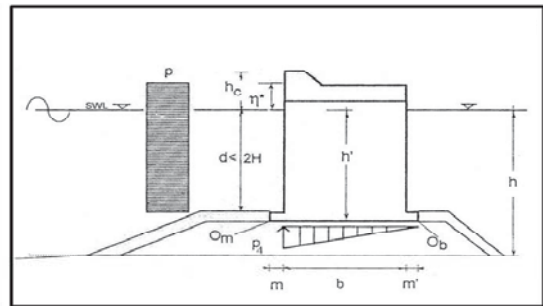

Fig. 13. Example of wave pressure distribution at a vertical face breakwater

In fact, owing to the particular nature of the soil in Japan, which makes rocks particularly fragile, Japanese are used to employ monolithic breakwaters even in shallow water, where the structures may interact with breakers somehow similar to those described above. Moreover, the walls are customary designed to be significantly overtopped during extreme storms. As shown in Fig. 14, the main hypothesis of present approach is that the distribution of wave pressure at vertical walls could be simply rotated on the sloping face of the SSG. This agrees with [6].

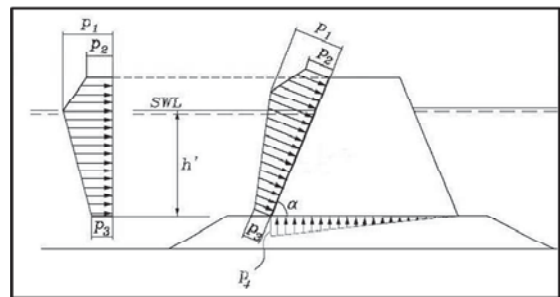

Fig. 14. Basic assumption of present approach.

A second point concerns the value of the maximum vertical load. From Fig. 14 would follow it to be equal to the difference between the uplift pressures at the bottom and the vertical component of the force acting at the sloping front face. However, since the peak of the vertical force has been seen to

anticipate the peak of the horizontal force, it has been conservatively assumed the former to be simply equal to the resultant of the uplift pressures acting at the bottom. This implies the horizontal force is thought to be zero when the vertical force attains its peak.

In the calculations the well known methods of Hiroi and Goda [7] have been employed. Note these methods are merely deterministic; they require the use of a single wave statistics and return a single value of force, which is representative of the maximum peak. The characteristic wave height employed in present paper has been $1.8 H_{m0}$ for the Goda model and H_{m0} for the Hiroi formula. Here H_{m0} represents the spectral significant wave height of the incoming wave field seaward the 1:5 slope. Predicted values of force have been compared to the average of the $1/250^{\text{th}}$ of the highest peaks of force measured during each storm ($F_{1/250}$).

Results of calculations are reported in Tables II and III.

TABLE II
MEASURED AND PREDICTED VALUES OF THE HORIZONTAL FORCES [KG/M]

Test code	$F_{h,MEAS}$	Goda		Hiroi	
		$F_{h,calc.}$	SF	$F_{h,calc.}$	SF
TEST 1	25.86	44.34	1.71	52.80	2.04
TEST 2	27.14	46.68	1.72	55.88	2.06
TEST 3	23.14	42.86	1.85	50.67	2.19
TEST 4	39.92	43.73	1.10	51.85	1.30
TEST 5	38.53	44.77	1.16	53.27	1.38

TABLE III
MEASURED AND PREDICTED VALUES OF THE VERTICAL FORCES [KG/M]

Test code	$F_{v,MEAS}$	Goda		Hiroi	
		$F_{v,calc.}$	SF	$F_{v,calc.}$	SF
TEST 1	31.84	80.85	2.54	41.26	1.30
TEST 2	33.96	85.88	2.53	43.66	1.29
TEST 3	31.37	77.88	2.48	39.59	1.26
TEST 4	34.33	79.70	2.32	40.52	1.18
TEST 5	35.11	81.88	2.33	41.63	1.19

The Tables show predicted values are rather safe, with factors (SF) ranging between 1.5 and 2.5.

As far as the overturning torque is concerned, a safe estimate can be obtained considering the vertical peak alone (Table IV); this is consistent both with the previous hypothesis on the vertical force and with experimental evidence that vertical force and torque chronograms are perfectly in phase (Fig.12).

TABLE IV
MEASURED AND PREDICTED VALUES OF TORQUE [KG M/M]

Test code	M_{MEAS}	Goda		Hiroi	
		$M_{calc.}$	SF	$M_{calc.}$	SF
TEST 1	6.65	17.03	2.56	8.69	1.31
TEST 2	7.84	18.09	2.31	9.20	1.17
TEST 3	6.65	16.40	2.47	8.34	1.25
TEST 4	7.29	16.79	2.30	8.54	1.17
TEST 5	7.01	17.24	2.46	8.77	1.25

IV. CONCLUSIONS

The paper has presented results of small-scale experiments conducted to estimate the magnitude of wave force and pressure, acting on an overtopping driven device for the conversion of wave energy into electricity, named SSG. The prototype pilot project is to be built at Svåheia, along the South-West coast of Norway. Hydraulic model tests have been carried out at LInC laboratory of the Department of Hydraulic, Geotechnical and Environmental Engineering (DIGA) of the University of Naples Federico II; a Froude similitude criterion with a 66 scale ratio has been employed.

The paper has focused on the overall wave force components (horizontal force, vertical force and resulting torque), which have been measured through a ad hoc weighting system sampled at 100 Hz. The main feature of the horizontal loading component is the presence of a double hump in correspondence of the wave crest; the latter are known to be a result of wave breaking. In the present case we observed collapsing/surging breakers, with a bubbling water tongue that rapidly climb the steep foreshore. As far as the vertical component is concerned, the overtopping occurrence seems to be central in the force time history. In fact when the water overcomes the SSG roof, under the wave crest, the top pressures are sufficiently intense to lead the total force to become downward directed. Thus, during half a wave period we may have two force peaks and a trough. This feature has to be carefully considered in the time-domain analysis, to avoid an unrealistic overestimation of force events, which likely lower the value of extreme statistics. Otherwise, the time over which the structure is contemporaneously pushed landward and upwards becomes relatively short; this may require the structural response of the wall to be studied under a dynamical frame.

In the last section of the paper we proved two classical approaches of the Japanese design practice, namely Goda (1975) and Hiroi (1919), could be used to have safe estimates of measured loadings. In this view, it is important to mention that the extreme values of force at the front face and at the bottom do not occur at the same time. For this reason it has been crudely suggested of not accounting of the former, when estimating the maximum vertical force as well as the overturning torque. However, the application of those models gives estimations rather cautious, which could be not ever cost-effective; the improvement of their usage, based on supplementary (and wide) datasets, as well as the analysis about the need of a new design method will be among the scopes of the future research developments.

ACKNOWLEDGMENT

The Authors gratefully acknowledge Dr. Andrea Bove (University of Naples) for his technical assistance.

REFERENCES

- [1] J. A. Zelt and J. E. Skjelbreia, "Estimating incident and reflected wave fields using an arbitrary number of wave gauges", in *Proc. ICCE'92*, 1992, p.466
- [2] P.D. Welch, "The use of Fast Fourier Transform for the Estimation of Power Spectra: A Method Based on Time Averaging Over Short,

- Modified Periodograms”, *IEEE Transactions On Audio and Electroacoustics*, AU-15, 70-73,1967
- [3] L. Hamm and C. Peronnard, “Wave parameters in the nearshore: A clarification”, *Coastal Engineering*, 32(2-3), pp.119-135, 1997
- [4] C. J. Galvin, “Breaker type classification on three laboratory beaches,” *Journal of Geophysical Research*, vol.73(12), p. 3651, 1968.
- [5] M. J. Walkden, D. J. Wood, T. Bruce and D.H. Peregrine, “Impulsive seaward loads by wave overtopping on caisson breakwaters,” *Coastal Engineering*, 42 pp.257-76, 2001
- [6] K. Tanimoto and K. Kimura, “Hydraulic Experiment Study on Trapezoidal Caisson Breakwaters”, Technical Note N.528, Port and Harbor Research Institute, Yokosuka, Japan, 1985
- [7] Y. Goda, *Random Seas and Design of Maritime Structure*. University of Tokyo, Press, Tokyo, Japan, 1985