



Hierarchical Control Scheme for Voltage Unbalance Compensation in Islanded Microgrids

Savaghebi, Mehdi; Guerrero, Josep M.; Jalilian, Alireza ; Vasquez, Juan Carlos

Published in:

Proceedings of the 37th Annual Conference of IEEE Industrial Electronics Society, IECON 2011

DOI (link to publication from Publisher):

[10.1109/IECON.2011.6119815](https://doi.org/10.1109/IECON.2011.6119815)

Publication date:

2011

Document Version

Early version, also known as pre-print

[Link to publication from Aalborg University](#)

Citation for published version (APA):

Savaghebi, M., Guerrero, J. M., Jalilian, A., & Vasquez, J. C. (2011). Hierarchical Control Scheme for Voltage Unbalance Compensation in Islanded Microgrids. In *Proceedings of the 37th Annual Conference of IEEE Industrial Electronics Society, IECON 2011* (pp. 3158-3163). IEEE Press.
<https://doi.org/10.1109/IECON.2011.6119815>

General rights

Copyright and moral rights for the publications made accessible in the public portal are retained by the authors and/or other copyright owners and it is a condition of accessing publications that users recognise and abide by the legal requirements associated with these rights.

- Users may download and print one copy of any publication from the public portal for the purpose of private study or research.
- You may not further distribute the material or use it for any profit-making activity or commercial gain
- You may freely distribute the URL identifying the publication in the public portal -

Take down policy

If you believe that this document breaches copyright please contact us at vbn@aub.aau.dk providing details, and we will remove access to the work immediately and investigate your claim.

Hierarchical Control Scheme for Voltage Unbalance Compensation in Islanded Microgrids

Mehdi Savaghebi¹, Josep M. Guerrero^{2,3}, Alireza Jalilian¹, and Juan C. Vasquez³

¹Center of Excellence for Power System Automation and Operation, Iran University of Science and Technology, Iran

²Department of Automatic Control and Industrial Informatics, Technical University of Catalonia, Spain

³Institute of Energy Technology, Aalborg University, Denmark

savaghebi@iust.ac.ir, joz@et.aau.dk, jalilian@iust.ac.ir, juq@et.aau.dk

Abstract— The concept of microgrid hierarchical control is presented, recently. In this paper, a hierarchical scheme which includes primary and secondary control levels is proposed for islanded microgrids. The primary control level consists of DG local controllers. Local controller of each DG comprises active and reactive power controllers, virtual impedance loop and voltage and current controllers. The secondary level is designed to compensate the voltage unbalance at the load bus (LB) of the islanded microgrid. Also, restoration of LB voltage amplitude and microgrid frequency to the rated values is considered in the secondary level. These functions are achieved by proper control of distributed generators (DGs) interface converters. The presented simulation results show the effectiveness of the proposed control structure in compensating the voltage unbalance and restoring the voltage amplitude and system frequency.

Keywords—distributed generation; microgrid; hierarchical control; voltage unbalance compensation

I. INTRODUCTION

Voltage unbalance can result in adverse effects on equipment and power system. Under unbalanced conditions, the power system will incur more losses and be less stable. Also, voltage unbalance has some negative impacts on equipment such as induction motors, power electronic converters and adjustable speed drives (ASDs). Thus, the International Electrotechnical Commission (IEC) recommends the limit of 2% for voltage unbalance in electrical systems [1]. A major cause of voltage unbalance is the connection of unbalanced loads (mainly, single-phase loads connection between two phases or between one phase and the neutral).

Compensation of voltage unbalance is usually done using series active power filter through injection of negative sequence voltage in series with the power distribution line [2]-[4]. However, there are a few works [5]-[8] based on using shunt active power filter for voltage unbalance compensation. In these works, voltage unbalance caused by unbalanced load is compensated through balancing the line currents.

On the other hand, it is well-known that the Distributed Generators (DGs) often consist of a prime mover connected through an interface converter (e.g. an inverter in the case of dc-to-ac conversion) to the ac power distribution system.

The distribution system may be the utility grid or the local grid formed by a cluster of DGs which is called microgrid. The main role of DG inverter is to adjust output voltage phase angle and amplitude in order to control the active and reactive power injection. In addition, compensation of power quality problems, such as voltage unbalance can be achieved through proper control strategies. In [9]-[12], some approaches are presented to use the DG for voltage unbalance compensation.

A method for voltage unbalance compensation through injection of negative sequence current by the DG has been proposed in [9]. By applying this method, line currents become balanced in spite of the unbalanced loads presence. However, under severely unbalanced conditions, a large amount of the interface converter capacity is used for compensation and it may interfere with the active and reactive power supply by the DG.

The approach presented in [10] is based on controlling the DG as a negative sequence conductance to compensate the voltage unbalance at the microgrid DGs output. In this approach which is implemented in the synchronous (dq) reference frame, compensation is done by generating a reference for negative sequence conductance based on the negative sequence reactive power. Then, this conductance is applied to produce the compensation reference current.

In [11] some improvements are made to the approach of [10]. Also, it is noteworthy that the control system of [11] is completely designed in stationary ($\alpha\beta$) reference frame. A similar control structure is applied for a grid-connected DG [12], where a PI controller is used to follow the reference of voltage unbalance factor.

The methods proposed in [10]-[12] are designed for compensation of voltage unbalance compensation at the DG terminal, while usually the power quality at the load bus (LB) is the main concern; since, sensitive loads maybe connected to LB. Thus, in this paper the concept of microgrid secondary control [13] is applied to compensate the voltage unbalance at LB in an islanded microgrid. Also, restoration of LB voltage amplitude and microgrid frequency to the rated values is considered in the control structure.

Proportional-integral (PI) controllers are used to generate the reference control signals at the central secondary controller. These references are sent to DGs local controllers by low band-width communication (*LBC*).

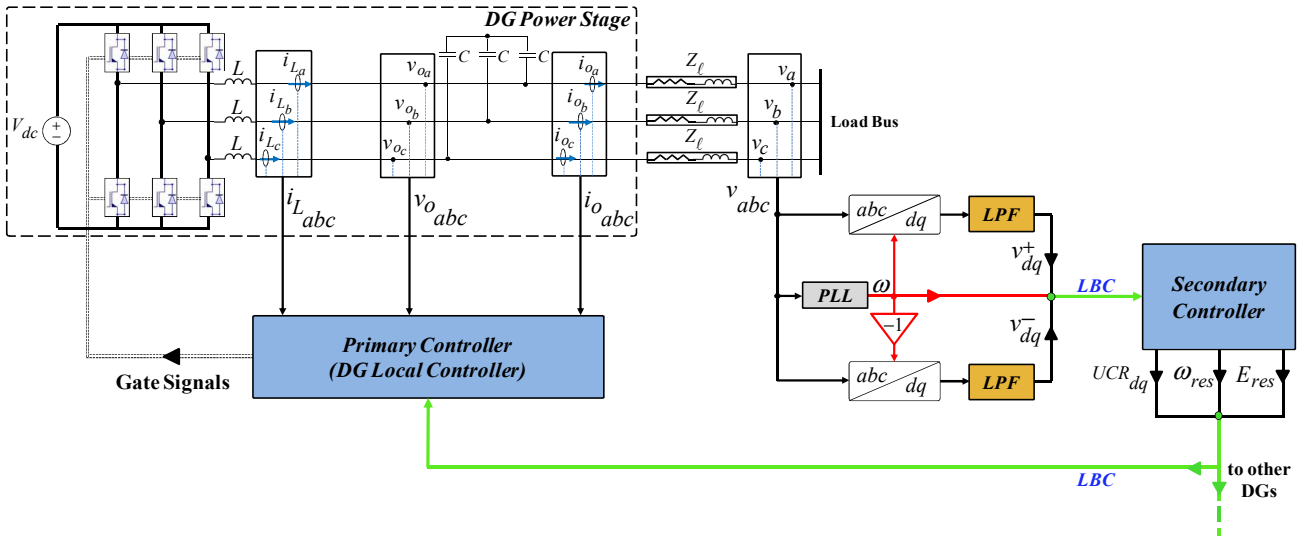

Fig. 1. Power stage and hierarchical control scheme.

II. MICROGRID HIERARCHICAL CONTROL SCHEME

According to [13] microgrid hierarchical control structure is organized in three-levels: primary, secondary and tertiary. The primary consists of DGs local controllers. In the present paper, the local controller of each DG comprises voltage and current controllers, virtual impedance loop and active/reactive power droop controllers.

In [13] the secondary control level is conceived to restore the DG output voltage frequency and amplitude deviations produced by the droop controllers and output impedances. Since, the main focus of the present paper is the voltage quality at LB; the responsibilities of the secondary controller are considered as follow:

- Microgrid frequency restoration
- LB voltage amplitude restoration
- LB voltage unbalance compensation

The tertiary control level of [13] regulates the power flow between the grid and the microgrid. Since, in the present paper the microgrid is operating in islanded mode, this control level is not considered.

The proposed hierarchical control structure is shown in Fig. 1. As seen, the local controller of each DG generates the gate signals for the interface inverter. The details are provided in the next section.

The secondary controller can be far from DGs and LB. Thus, a communication medium is necessary to send the LB voltage and microgrid frequency information to this controller. Also, the control signals for voltage unbalance compensation (UCR_{dq} : *Unbalance Compensation Reference*), voltage amplitude restoration (E_{res}) and frequency restoration (ω_{res}) are sent by communication to the DGs local controllers at primary level. In order to ensure that LBC is sufficient, the transmitted data should be approximately dc signals.

As seen in Fig. 1, in order to extract LB voltage (v_{abc}) positive and negative sequences, v_{abc} is transformed to dq reference frames rotating with ω and $-\omega$. Then, two low

pass filters (LPF) are used to extract positive and negative sequences (v_{dq}^+ and v_{dq}^-), respectively. These signals are transmitted toward the central controller.

The block diagram of the secondary controller is shown in Fig. 2. As seen, v_{dq}^+ and v_{dq}^- are used to calculate “*Voltage Unbalance Factor (VUF)*”. Then, the calculated value is compared with the reference VUF^* and the error is fed to a PI controller. Afterwards, the output of PI controller is multiplied by v_{dq}^- to generate UCR_{dq} .

Also, according to Figs. 1 and 2, ω is sent to the secondary controller through LBC and then, compared with the rated angular frequency ($\omega_0=100\pi$). The error is fed to a PI controller which generates the frequency restoration signal (ω_{res}). As shown in Fig. 3, ω_{res} is fed to the DG active power droop controller to compensate the frequency drop caused by this controller.

On the other hand, positive sequence voltage amplitude is compared with the rated amplitude ($E_{0dq} = 230\sqrt{3}$ in dq frame) and using a PI controller, E_{res} is generated and then transmitted through LBC . As shown in Fig. 3, E_{res} is fed to the DG reactive power droop controller. This way, the voltage drop caused by the reactive power droop controller, output impedance and distribution lines impedance between DG and LB is compensated. More details on frequency and amplitude restoration can be found in [13].

III. PRIMARY CONTROL LEVEL

As shown in Fig. 3, the voltage controller follows the references generated by power controllers and secondary level and generates the reference for the current controller. The output of the current controller is transformed back to abc frame to provide three-phase voltage reference for the pulse width modulator (PWM). Finally, the PWM block controls the switching of the inverter based on this reference. More details are provided in the following Subsections.

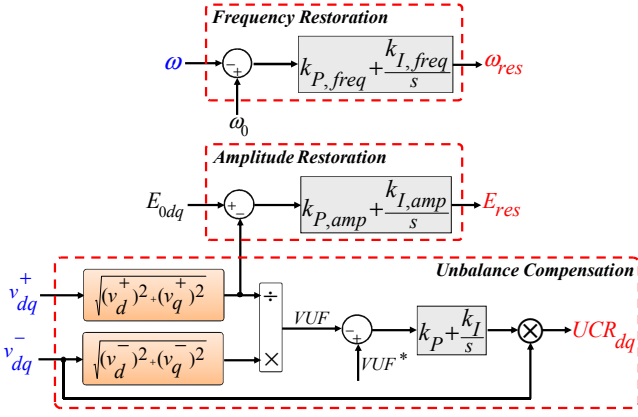

Fig. 2. Block diagram of secondary control level.

A. Active and Reactive Power Control

Considering a DG which is connected to the grid through a mainly inductive impedance $X \angle 90^\circ$, the active and reactive powers injected to the grid by the DG can be approximated as follows [14], [15]:

$$P \approx \frac{EV}{X} \phi \quad (1)$$

$$Q \approx \frac{V}{X} (E - V) \quad (2)$$

Thus, active and reactive powers can be controlled by the DG output voltage phase angle and amplitude, respectively. According to this, the following droop characteristics are considered for the positive sequence active and reactive power sharing among the DGs of an islanded microgrid:

$$\phi^* = [\phi_0 + \int \omega_{res} dt] - (m_P P^+ + m_I \int P^+ dt) \quad (3)$$

$$E^* = (E_0 + E_{res}) - n_P Q^+ \quad (4)$$

where

- E_0 : rated voltage amplitude
- ϕ_0 : rated phase angle ($\phi_0 = \int \omega_0 dt = \omega_0 t$)
- ω_0 : rated angular frequency
- P^+ : positive sequence active power
- Q^+ : positive sequence reactive power
- m_P : active power proportional coefficient
- m_I : active power integral coefficient
- n_P : reactive power proportional coefficient
- E^* : voltage amplitude reference
- ϕ^* : voltage phase angle reference

In fact, equation (3) acts as a proportional-derivative controller for frequency. The derivative terms (m_P) helps to improve the dynamic behavior of the power control [14]. It is noteworthy that according to the equations (3) and (4), no integral term is considered for voltage frequency and amplitude control. When the microgrid is operating in islanded mode (the case considered in this paper) the use of pure integrators is not allowed, since the total load will not

coincide with the total injected power, and it leads to instability [13], [16].

As it can be seen in Fig. 3, E^* and ϕ^* are used to generate the three phase reference voltages of the inverter. These voltages are positive-sequence components; thus positive sequence powers (P^+ and Q^+) are used in equations (3) and (4). The details of power calculation are presented in the next Subsection.

B. Power Calculation

Based on the instantaneous reactive power theory [17], the instantaneous values of active and reactive powers should be calculated using equations (5) and (6), respectively:

$$p = v_{o\alpha} i_{o\alpha} + v_{o\beta} i_{o\beta} \quad (5)$$

$$q = v_{o\beta} i_{o\alpha} - v_{o\alpha} i_{o\beta} \quad (6)$$

Each of the instantaneous powers calculated using (5) and (6) consists of dc and ac (oscillatory) components. The dc components (average values of p and q) are positive sequence active and reactive powers (P^+ and Q^+ , respectively) [18]. The oscillatory parts are generated by the unbalance and/or harmonic contents of the voltage and current.

The dc components are extracted using two 1st order low pass filters. The cut-off frequency of these filters is set to 2Hz.

C. Virtual Impedance Loop

Addition of the virtual resistance makes the oscillations of the system more damped [14]. In contrast with physical resistance, the virtual resistance has no power losses, and it is possible to implement it without decreasing the efficiency.

The virtual inductance is considered to ensure the decoupling of P and Q . Thus, virtual impedance makes the droop controllers more stable [19].

The virtual impedance can be achieved as shown in Fig. 4, where R_v and L_v are the virtual resistance and inductance values, respectively [20]. As shown in Fig. 3, only positive sequence current is passing through virtual impedance. In this way, increase of DG output voltage unbalance due to the negative sequence voltage drop on the virtual impedance will be avoided. Positive sequence is extracted according to [21] and [22].

D. Voltage and Current Controllers

Due to the difficulties of using proportional-integral (PI) controllers to track non-dc variables, proportional-resonant (PR) controllers are usually preferred to control the voltage and current in stationary reference frame [23]. In this paper, PR voltage and current controllers are as (7) and (8):

$$G_V(s) = k_{pV} + \frac{2k_{rV}\omega_{cV}s}{s^2 + 2\omega_{cV}s + \omega^2} \quad (7)$$

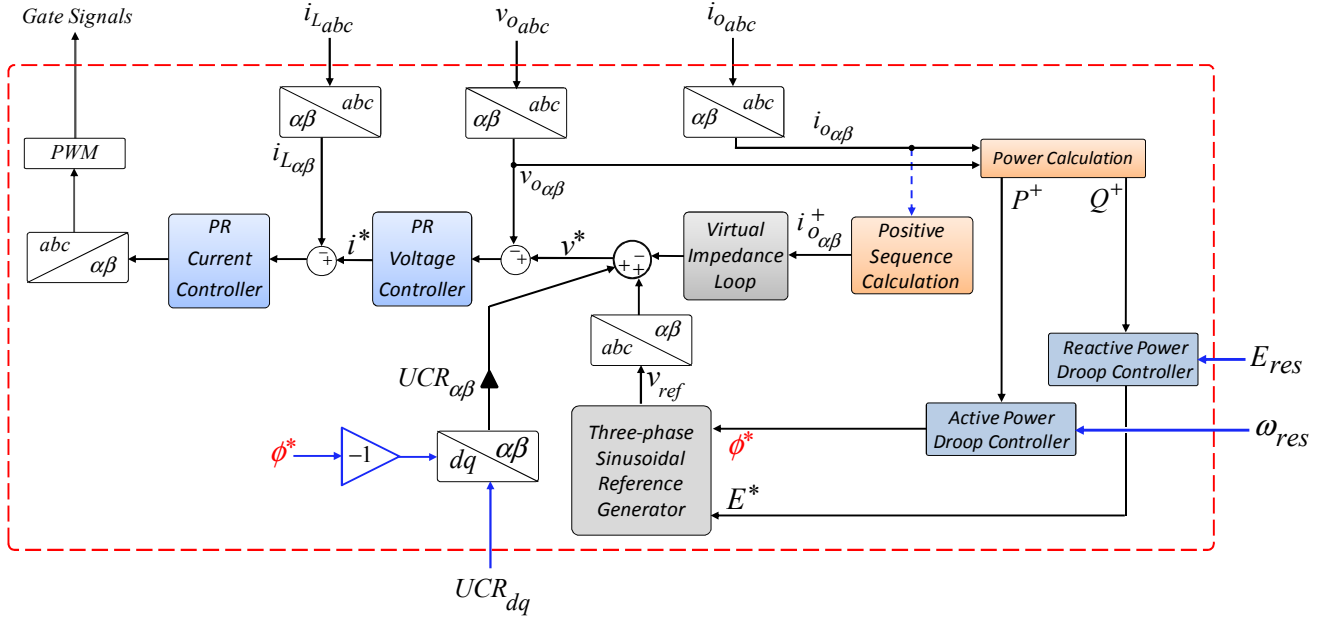

Fig. 3. Schematic diagram of primary control level.

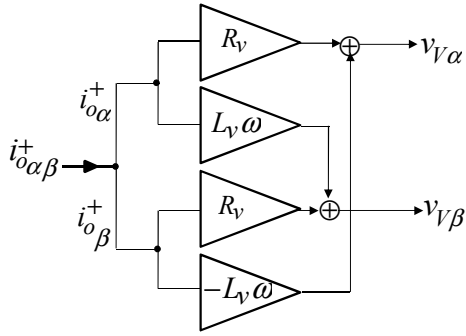

Fig. 4. Virtual impedance block diagram

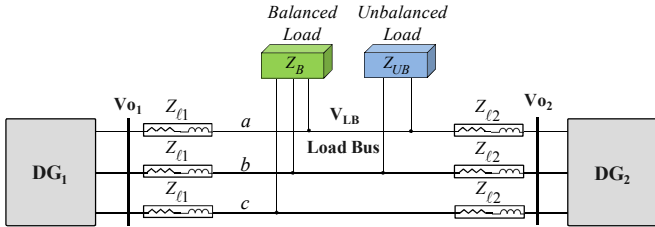

Fig. 5. Test system for simulation studies

$$G_I(s) = k_{pI} + \frac{2k_{rI}\omega_{cI}s}{s^2 + 2\omega_{cI}s + \omega^2} \quad (8)$$

where, k_{pV} (k_{pI}) and k_{rV} (k_{rI}) are the proportional and resonant coefficients of the voltage (current) controller, respectively. Also, ω_{cV} and ω_{cI} represent the voltage and current controller cut-off frequencies, respectively.

IV. SIMULATION RESULTS

The islanded microgrid of Fig. 5 is considered as the test system. This microgrid includes two DGs with power stage

and control system shown in Fig. 1. The parameters of power stage and control system are listed in Tables I-III. Switching frequency of the DGs inverters is set to 10 kHz. As seen in Fig. 5, a single-phase load is connected between phases “a” and “b” which causes voltage unbalance. A balanced star-connected three-phase load is also connected to load bus. In this Fig. Z_{l1} and Z_{l2} represent the distribution lines between DGs and LB.

Frequency and amplitude restoration are activated at $t=2\text{sec}$. Then, unbalance compensation starts acting from $t=3.5\text{sec}$. VUF^* is set to 0.5%.

As shown in Fig. 6, VUF of LB follows the reference value, properly. Also, it can be seen that the improvement of LB voltage quality is achieved by making the DGs output voltage unbalanced. Due to less line impedance between DG₂ and the LB; its VUF is increased a little more.

Fig. 7 shows three-phase voltages at LB and DGs terminal. As seen, as a result of amplitude restoration and unbalance compensation, the amplitude of LB voltage is increased and its unbalance is compensated, effectively; while the DGs output voltages become unbalanced.

The variations of microgrid frequency and LB rms voltage can be observed in Figs. 8(a) and 8(b), respectively. It can be clearly seen that the frequency and LB voltage are properly regulated to the rated values and the unbalance compensation doesn't interfere with the restoration.

Sharing of P^+ and Q^+ is shown in Fig. 9. As seen, in spite of asymmetrical distribution lines ($Z_{l1} = 3 \cdot Z_{l2}$) active and reactive powers are shared properly between the DGs. Also, as expected, due to frequency and amplitude restoration, active and reactive powers are increased. Furthermore, it can be seen that unbalance compensation doesn't change the positive sequence power sharing; since, the compensation is acting over negative sequence.

TABLE I
POWER STAGE PARAMETERS

DG prime mover	inverter filter inductance	inverter filter capacitance	DG1 distribution line	DG2 distribution line	Unbalanced load	Balanced load
V_{dc} (V)	L (mH)	C (μF)	$Z_{\ell 1}$ (Ω)	$Z_{\ell 2}$ (Ω)	Z_{UB} (Ω)	Z_B (Ω)
650	1.8	25	$0.6+j1.68$	$0.2+j0.56$	500	$50+j6.3$

TABLE II
PRIMARY CONTROL LEVEL PARAMETERS

Power Controllers				Virtual Impedance		Voltage Controller			Current Controller			
m_p	m_i	n_p	E_0	ω_0	R_v (Ω)	L_v (mH)	k_{pv}	k_{rv}	ω_{cv}	k_{pi}	k_{ri}	ω_{ci}
0.00002	0.0002	0.08	$230\sqrt{2}$	$2\pi*50$	1	4	2	100	2	10	1000	2

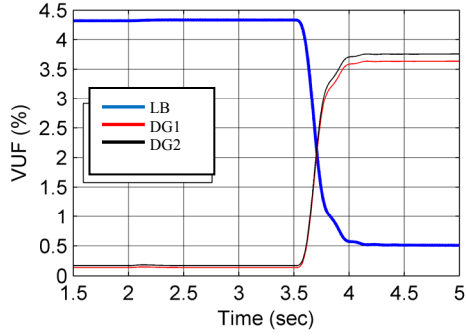
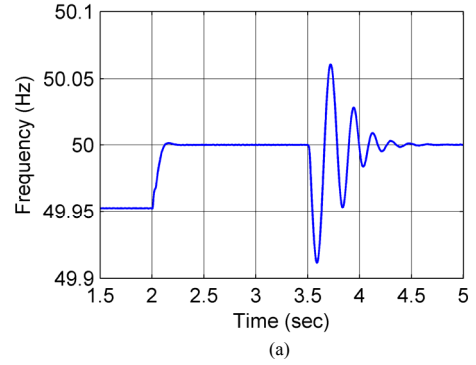

Fig. 6. VUF at LB and DGs terminal



(a)

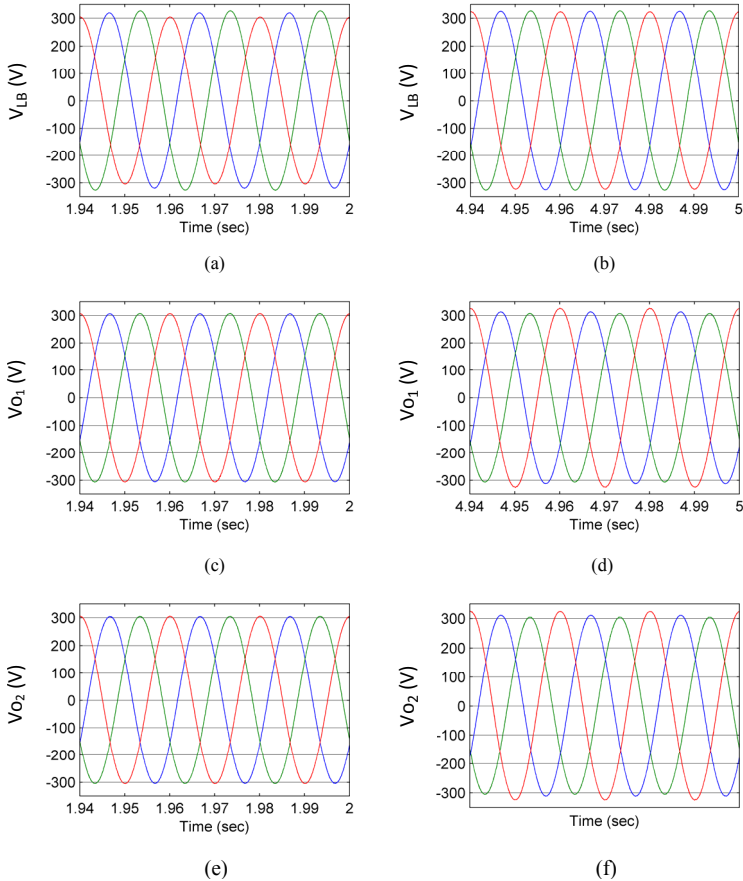
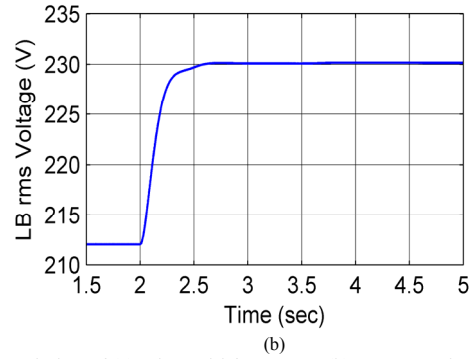

Fig. 7. Three-phase voltages before and after secondary control activation (a) LB-before (b) LB-after, (c) DG₁-before (d) DG₁-after, (e) DG₂-before (f) DG₂-after



(b)

Fig. 8. Variation of (a) microgrid frequency, (b) LB rms voltage

V. CONCLUSIONS

A hierarchical control approach for regulation of load bus voltage in an islanded microgrid is proposed. The control structure consists of DGs local controllers (primary level), and a central secondary controller. The secondary controller is responsible for frequency restoration, LB voltage amplitude restoration and its unbalance compensation. The estimated frequency, LB voltage data and the control signals are transmitted to/from this controller by low bandwidth communication. The presented simulation results show that the LB voltage unbalance is properly compensated to the desired value and LB voltage amplitude and the microgrid frequency are regulated to the rated values.

TABLE III
SECONDARY CONTROL LEVEL PARAMETERS

Frequency Restoration		Amplitude Restoration		Unbalance Compensator	
$k_{P,freq}$	$k_{I,freq}$	$k_{P,amp}$	$k_{I,amp}$	k_P	k_I
0.02	0.15	0.2	0.15	0.25	8.5

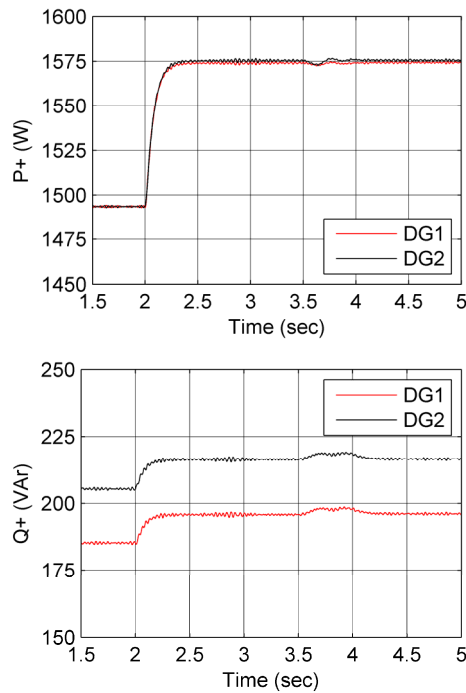

Fig. 9. Active and reactive power sharing

REFERENCES

- [1] A. V. Jouanne, and B. Banerjee, "Assessment of voltage unbalance," *IEEE Trans. Pow. Deliv.*, vol. 16, no. 4, pp. 782-790, Oct. 2001.
- [2] F. Barrero, S. Martínez, F. Yeves, F. Mur, and P. Martínez, "Universal and reconfigurable to UPS active power filter for line conditioning," *IEEE Trans. Pow. Deliv.*, vol. 18, no. 1, pp. 283-290, Jan. 2003.
- [3] D. Graovac, V. A. Katic', and A. Rufer, "Power quality problems compensation with universal power quality conditioning system," *IEEE Trans. Pow. Deliv.*, vol. 22, no. 2, pp. 968-976, Apr. 2007.
- [4] B. Singh, K. Al-Haddad, and A. Chandra, "A review of active filters for power quality improvement," *IEEE Trans. Ind. Elec.*, vol. 46, no. 5, pp. 960-971, Oct. 1999.
- [5] A. G. Cerrada, O. P. Ardila, V. F. Batlle, P. R. Sánchez, and P. G. González, "Application of a repetitive controller for a three-phase active power filter," *IEEE Trans. Pow. Elec.*, vol. 22, no. 1, pp. 237-246, Jan. 2007.
- [6] A. Chandra, B. Singh, B. N. Singh, and K. Al-Haddad, "An improved control algorithm of shunt active filter for voltage regulation, harmonic elimination, power factor correction, and balancing of nonlinear loads," *IEEE Trans. Pow. Elec.*, vol. 15, no. 3, pp. 495-507, May 2000.
- [7] B. Singh, and J. Solanki, "An implementation of an adaptive control algorithm for a three-phase shunt active filter," *IEEE Trans. Ind. Elec.*, vol. 56, no. 8, pp. 2811-2820, Aug. 2009.

- [8] S. George, and V. Agarwal, "A DSP based optimal algorithm for shunt active filter under nonsinusoidal supply and unbalanced load conditions," *IEEE Trans. Pow. Elec.*, vol. 22, no. 2, pp. 593-601, Mar. 2007.
- [9] M. Hojo, Y. Iwase, T. Funabashi, and Y. Ueda, "A method of three-phase balancing in microgrid by photovoltaic generation systems," in *Proc. Power Elec. and Motion Cont. Conf. (EPE-PEMC)*, pp. 2487-2491, Sept. 2008.
- [10] P. T. Cheng, C. Chen, T. L. Lee and S. Y. Kuo, "A cooperative imbalance compensation method for distributed-generation interface converters," *IEEE Trans. Ind. Appl.*, vol. 45, no. 2, pp. 805-815, Mar./Apr. 2009.
- [11] M. Savaghebi, J. M. Guerrero, A. Jalilian, and J. C. Vasquez, "Experimental evaluation of voltage unbalance compensation in an islanded microgrid," accepted for presentation in *20th IEEE Int. Symp. on Ind. Elec. (ISIE 2011)*, Jun. 2011.
- [12] M. Savaghebi, A. Jalilian, J. C. Vasquez, J. M. Guerrero, and R. Teodorescu, "Distributed generator with voltage unbalance compensation capability," in *Proc. 25th Int. Pow. Sys. Conf. (PSC 2010)*, pp. 1-10, Nov. 2010. (available online: www.psc-ir.com/ed10/10-E-PQA-1943.pdf).
- [13] J. M. Guerrero, J. C. Vasquez, J. Matas, L. G. de Vicuña, and M. Castilla, "Hierarchical control of droop-controlled AC and DC microgrids—a general approach toward standardization," *IEEE Trans. Ind. Elec.*, vol. 58, no. 1, pp. 158-172, Jan. 2011.
- [14] J. M. Guerrero, J. Matas and L. G. de Vicuña, M. Castilla, and J. Miret, "Decentralized control for parallel operation of distributed generation inverters using resistive output impedance," *IEEE Trans. Ind. Elec.*, vol. 54, no. 2, pp. 994-1004, Apr. 2007.
- [15] E. Barklund, N. Pogaku, M. Prodanovic', C. H. Aramburo, and T. C. Green, "Energy management in autonomous microgrid using stability-constrained droop control of inverters," *IEEE Trans. Pow. Elec.*, vol. 23, no. 5, pp. 2346-2352, Sept. 2008.
- [16] Y. Li, D. M. Vilathgamuwa, and P. C. Loh, "Design, analysis, and real-time testing of a controller for multibus microgrid system," *IEEE Trans. Pow. Elec.*, vol. 19, no. 5, pp. 1195-1204, Sept. 2004.
- [17] H. Akagi, Y. Kanagawa, and A. Nabase, "Instantaneous reactive power compensator comprising switching devices without energy storage components," *IEEE Trans. Ind. Appl.*, vol. IA-20, no. 3, p. 625, May/June. 1984.
- [18] F. Z. Peng, G. W. Ott, and D. J. Adams, "Harmonic and reactive power compensation based on the generalized instantaneous reactive power theory for three-phase four-wire systems," *IEEE Trans. Pow. Elec.*, vol. 13, no. 6, pp. 1174-1181, Nov. 1998.
- [19] J. M. Guerrero, L. G. Vicuna, J. Matas, M. Castilla, and J. Miret, "Output impedance design of parallel-connected UPS inverters with wireless load sharing control," *IEEE Trans. Ind. Elec.*, vol. 52, no. 4, pp. 1126-1135, Aug. 2005.
- [20] J. He, and Y. W. Li "Analysis and design of interfacing inverter output virtual impedance in a low voltage microgrid," in *Proc. Energy Conv. Cong. and Exp. (ECCE)*, pp. 2857-2864, Sept. 2010.
- [21] M. Ciobotaru, R. Teodorescu, and F. Blaabjerg, "A new single-phase PLL structure based on second order generalized integrator," in *Proc. Pow. Elec. Specialists Conf. (PESC)*, pp. 1-6, Oct. 2006.
- [22] P. Rodriguez, A. V. Timbus, R. Teodorescu, M. Liserre and F. Blaabjerg, "Flexible active power control of distributed power generation systems during grid faults," *IEEE Trans. Ind. Elec.*, vol. 54, no. 5, pp. 2583-2592, Oct. 2007.
- [23] F. Blaabjerg, R. Teodorescu, M. Liserre and A. V. Timbus, "Overview of control and grid synchronization for distributed power generation systems," *IEEE Trans. Ind. Elec.*, vol. 53, no. 5, pp. 1398-1409, Oct. 2006.