



Aalborg Universitet

AALBORG UNIVERSITY
DENMARK

Reliability Based Optimal Design of Vertical Breakwaters Modelled as a Series System Failure

Christiani, E.; Burcharth, H. F.; Sørensen, John Dalsgaard

Published in:
Coastal Engineering

Publication date:
1996

Document Version
Publisher's PDF, also known as Version of record

[Link to publication from Aalborg University](#)

Citation for published version (APA):

Christiani, E., Burcharth, H. F., & Sørensen, J. D. (1996). Reliability Based Optimal Design of Vertical Breakwaters Modelled as a Series System Failure. In B. L. Edge (Ed.), *Coastal Engineering : Proceedings of the twenty-fifth international conference* (pp. 1589-1602). New York: American Society of Civil Engineers.

General rights

Copyright and moral rights for the publications made accessible in the public portal are retained by the authors and/or other copyright owners and it is a condition of accessing publications that users recognise and abide by the legal requirements associated with these rights.

- ? Users may download and print one copy of any publication from the public portal for the purpose of private study or research.
- ? You may not further distribute the material or use it for any profit-making activity or commercial gain
- ? You may freely distribute the URL identifying the publication in the public portal ?

Take down policy

If you believe that this document breaches copyright please contact us at vbn@aub.aau.dk providing details, and we will remove access to the work immediately and investigate your claim.

CHAPTER 124

Reliability based optimal design of vertical breakwaters modelled as a series system of failure

E. Christiani ¹ H.F. Burcharth ² J. Dalsgaard Sørensen ³

Abstract

Reliability based design of monolithic vertical breakwaters is considered. Probabilistic models of important failure modes such as sliding and rupture failure in the rubble mound and the subsoil are described. Characterisation of the relevant stochastic parameters are presented, and relevant design variables are identified and an optimal system reliability formulation is presented. An illustrative example is given.

Keywords: Vertical wall breakwaters, sliding failure, rupture failure, design optimisation, reliability

Introduction

A number of breakwater failures have been reported during the last 20 years for rubble mound breakwaters as well as for vertical breakwaters e.g. Sines (Portugal), Arzew (Alger), Mutsu-Ogawara Port (Japan), Gela (Italy) and Algeciras Port (Spain). This has resulted in new ways of approaching the design problems related to breakwaters. Probabilistic methods have been introduced to solve breakwater design problems in the early stage of planning. Reliability based design of breakwaters has been discussed by Nielsen et. al. (1983), Burcharth (1991), (1992a), (1992b), Burcharth et al. (1994) and (1995) and by Takayama (1994).

In the following a caisson vertical breakwater is analysed with respect to probability of failure for single failure modes. Emphasis is put on the foundation failure modes and their relative importance.

Identification of the failure modes

Sliding and rupture failure in the rubble mound foundation and in the subsoil are usually the most critical failure modes for vertical breakwaters. Other failure modes exist e.g. settlement of the caisson, seaward sliding, scour at the toe (subsoil and/or rubble mound), instability of the armour stones in the foundation, and structural failure of the caisson.

¹Ph.D.-student, Hydraulics and Coastal Eng. Lab., Dept. of Civil Eng., Aalborg University

²Prof. dr.techn., Hydraulics and Coastal Eng. Lab., Dept. of Civil Eng., Aalborg University

³Assoc. Prof. Ph.D., Dept. of Building Technology and Structural Engineering, Aalborg University

Nine foundation failure mechanisms including sliding are identified cf. Figure 1. Overturning is a relevant failure mode only in the cases of monolithic structures placed on very strong foundation soils or rock. The designs considered cover vertical breakwaters placed on low or high rubble mounds and sand or clay subsoils.

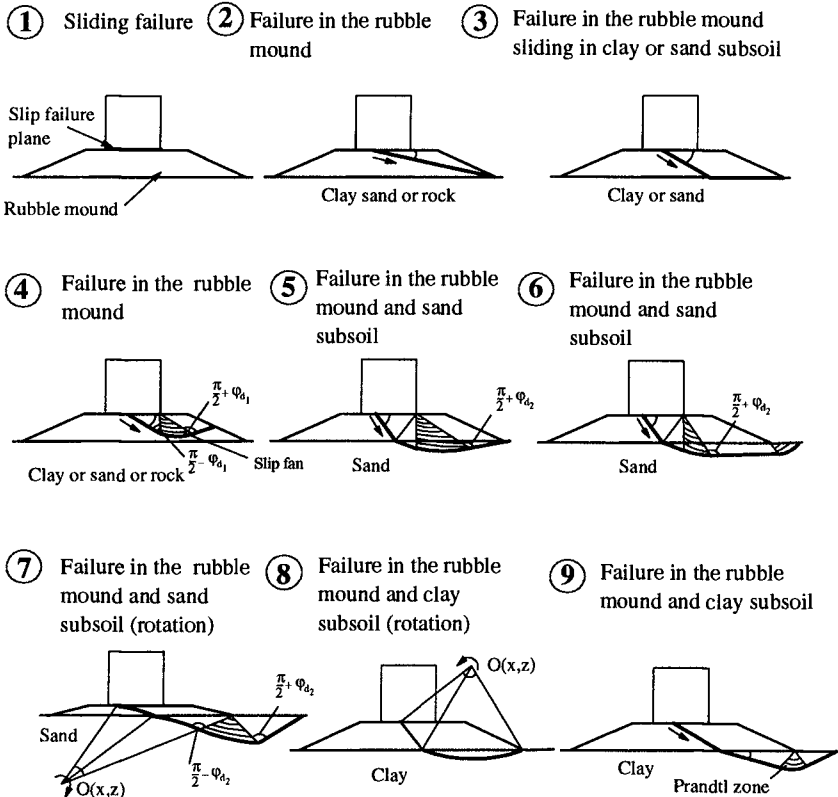

Figure 1: *Nine foundation rupture failure mechanisms*

Sliding

Sliding, i.e. horizontal displacement of the caisson, can occur as a slip either at the interface between the caisson concrete base plate and the rubble material, or entirely in the rubble material.

Corresponding to the first mentioned case stability against sliding exists when the ratio of the resultant horizontal force, F_H , to the resultant vertical force is equal to or less than $\tan \mu$, i.e.

$$F_H \leq (F_G - F_V) \tan \mu \tag{1}$$

where F_G is the weight of the caisson reduced for buoyancy, F_U is the wave induced uplift force on the base plate, and μ is the angle of friction between the concrete base plate and the rubble mound or the bedding layer. Reference is given to Takayama (1992) for values of $\tan \mu$.

If the sliding failure takes place entirely in the rubble material, e.g. in the bedding layer, then μ must be substituted by the effective angle of friction φ' of the material. The most critical of the two cases should be considered in the design.

F_H and F_U are in this paper calculated by using the wave load formulation by Goda et al. (1972) and (1974) extended to include impulsive pressure, Takahashi (1994). The design wave height is adjusted in the surf zone as described by Goda (1975).

The resultant of the forces F_H , F_G and F_U is indicated in Figure 2 as F_R .

Rupture failure in rubble, sand and clay subsoil - cases 1 - 9

To evaluate the stability of the foundation, consisting of the rubble mound, sand or clay subsoil, the upper bound theorem of general plasticity theory is used. This theorem can also be applied in a probabilistic approach of design.

Application of the upper bound theorem requires that the normality condition is fulfilled. Experience shows that good estimates of the bearing capacity can be obtained by introduction of a reduced effective angle of friction φ_d , Hansen (1979) defined by

$$\tan \varphi_d = \frac{\sin \varphi' \cos \psi}{1 - \sin \varphi' \sin \psi} \quad (2)$$

Both φ' and ψ are dependent on the stress level for which reason either reasonable mean values must be used, or calculations must be performed on increments.

Three dimensional effects are not included in the derivation of the zone rupture mechanism. The plane failure mode corresponding to case 8 is shown in Figure 2, where the line AB is approximately assumed to be a straight line. Note that it is assumed that tensile stresses cannot occur under the caisson base plate. Also note that because the caisson is a stiff body, the failure mechanism shown is not fully kinematic admissible. Actually, the intersection point A should be at the corner of the caisson, and the slip surface A-B is not necessarily a straight line. However, the rupture configuration is a close approximation as to the exact rupture mode can be demonstrated by comparison with results of finite element analyses.

Since the derivation of the mathematical formulation of the rupture failure modes 1 - 9 is rather lengthy, only rupture failure mode 8 will be discussed. Reference is given to Christiani (1996) for the rest of the failure modes.

Foundation in rubble and clay (rotation mechanism)

Case 8 in Figure 1 is considered.

The slip line AB is theoretically a logarithmic spiral. The areas, 1 and 2 move as stiff zones and interact with the clay subsoil, where a circular rupture zone evolves. The kinematic admissible rupture figure is described by a rotation mechanism about point D.

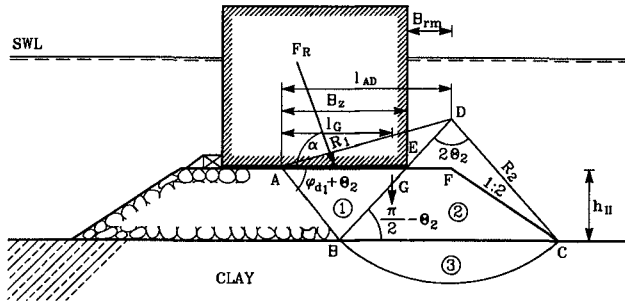

Figure 2: Rupture in the rubble mound and clay subsoil.

The geometrical lengths and the radius for the kinematically admissible rupture figure are cf. Figure 2.

$$l_{BC} = B_z + B_{rm} + 2h_{II} - \frac{h_{II}}{\tan(\varphi_{d1} + \theta_2)} \tag{3}$$

As noted above, the slip line AB is approximated by a straight line. The radius R_2 then becomes

$$R_2 = \frac{1}{2} l_{BC} / \sin \theta_2 \tag{4}$$

Further l_{AD} becomes

$$l_{AD} = \frac{h_{II}}{\tan(\varphi_{d1} + \theta_2)} + \frac{1}{2} l_{BC} \tag{5}$$

The centre of gravity for zone 1 and 2 is defined by the length l_G , cf. Figure 2

$$l_G = \frac{(l_{AD} - \frac{1}{2} l_{BC})(\frac{1}{3} l_{AD} + \frac{5}{6} l_{BC} - h_{II}) + \frac{1}{2} (l_{BC} - 2h_{II}) l_{BC} + \frac{2}{3} h_{II}^2}{\frac{1}{2} l_{AD} + \frac{3}{4} l_{BC} - h_{II}} \tag{6}$$

External work done

The external work W_E done by the wave loads, the pore pressure along the rupture boundary line and the weight of the vertical breakwater is for an infinitesimal rotation δ around point D

$$W_E = \delta M_o \tag{7}$$

where M_o is the moment around D of the wave loads, the pore pressure and the weight of the caisson.

The work done due to the weight of zones 1 and 2 is a rotation around D

$$W_{1,2} = \delta(\gamma_s - \gamma_w)(l_{AD} - l_G)(\Omega_1 + \Omega_2) \tag{8}$$

where Ω_1 and Ω_2 are the areas of zone 1 and 2, and $l_{AD} - l_G$ is the perpendicular length between the point of rotation and the center of gravity for zone 1 and 2.

The work done by the weight of zone 3 is zero as the resultant displacement of the centre of gravity is horizontal.

The internal work done in zone 3 along the rim of the rupture boundary BC is

$$W_3 = \delta R_2^2 \int_0^{2\theta_2} c_u(\theta) d\theta \tag{9}$$

where c_u is the undrained shear strength of the clay.

The limit state equation for the rupture mechanism in Figure 2 is then:

$$W_3 - W_{1,2} - W_E = 0 \tag{10}$$

θ_2 is the unknown angle to be determined by minimising the ratio between the stabilising work and driving work.

System model of failure modes for rupture failure and overturning

In design of vertical breakwaters, the main concern is sliding, overturning, and rupture failures in the rubble mound and in the subsoil. These failure modes can be modelled by a series systems cf. Figure 3.

a) Rubble mound and sand subsoil

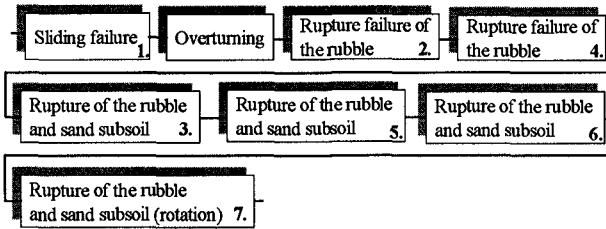

b) Rubble mound and clay subsoil

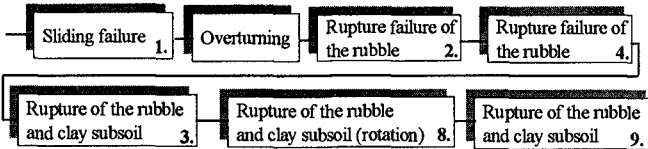

Figure 3: Series system of failure modes for rupture failure of the sand and clay subsoil.

Characterisation of the stochastic variables

All variables are in principle stochastic variables in a limit state formulation. Some parameters e.g. geometrical parameters have small coefficient of variation and might be regarded as deterministic variables. The parameters which have a significant degree of uncertainty in breakwater design will be discussed in the following. It is assumed that all stochastic variables are independent, unless otherwise stated in the text.

The wave induced horizontal force and the uplift force can be calculated from equations given by Goda et. al. (1974) and Takahashi (1994). The model uncertainty related to the *Goda wave load* is modelled by a normal distribution. This has been clarified by Bruining (1994) who compared a number of laboratory tests results with the Goda formula in order to evaluate the uncertainty related to the horizontal wave load, the wave induced uplift force, the horizontal moment and the wave induced uplift moment. The model uncertainties are represented by variables $U_{F_H}, U_{F_U}, U_{M_H}$ and U_{M_U} . Expected values (bias) and standard deviations are given in Table 2.

The *deep water wave climate* characterised by the significant wave height H_{so} is assumed to follow a Weibull distribution. The distribution function of the maximum significant wave height within T years is given by

$$F_{H_{so}^T}(H_{so}) = \left[1 - \exp \left(- \left(\frac{H_{so} - B_w}{A} \right)^k \right) \right]^{\lambda T} \tag{11}$$

where λ is the average number of H_{so} data values per year. $B_w = 2.69$ is usually regarded as a deterministic parameter.

Due to the limited number of data A and k are subject to statistical uncertainty. A and k values are modelled as normal distributed stochastic variables with a variance based on the maximum likelihood estimates. The expected value and the standard deviation of A and k are presented in Table 1.

	mean	standard deviation, σ
k	μ_k	$\simeq \sqrt{\frac{1}{N}}$ (approximation)
A	μ_A	$\left[\frac{\mu_A^2}{N} \left(\frac{\Gamma(1 + 2/\mu_k)}{\Gamma^2(1 + 1/\mu_k)} - 1 \right) \right]^{0.5} \simeq \mu_A \left(\frac{0.3}{N} \right)^{0.5}$

Table 1: Mean and standard deviation of A and k values in the Weibull distribution.

In Table 1 N is the number of available H_{so} -values and Γ is the gamma function. $\mu_A = 0.58$ and $\mu_k = 1.14$ and $N = 30$ will be used in the illustrative example, cf. Table 2.

As the water depth decreases from deep water to shallow water, wave transformation will result in refraction (when waves are not head on), shoaling and finally wave breaking. Therefore the uncertainty of the breaker heights should be considered in design in depth limited cases.

The *design wave height* $H_{design} = H_{1/250}$ to be applied in the Goda formula is in case of no surf zone in front of the structure taken as $1.8 \cdot H_{so}$.

i	X_i	Definition	Mean μ_{X_i}	Standard deviation σ_{X_i}	$\frac{\sigma_{X_i}}{\mu_{X_i}}$	Distribution	Reference
1	H_{so}	Deep water significant wave height (m)				weibull	Burcharth (1992)
2	k	Weibull parameter	1.14	0.15	0.13	normal	Burcharth (1994)
3	A	Weibull parameter	0.38	0.047	0.08	normal	Burcharth (1994)
4	ζ	Tidal elevation wave height (m)				cosine	Takayama (1992)
5	U_{FH}	Goda horizontal wave load	0.90	0.25	0.28	normal	Bruining (1994)
6	U_{Fv}	Goda wave induced uplift	0.77	0.25	0.32	normal	Bruining (1994)
7	U_{MH}	Horizontal moment about the heel	0.81	0.41	0.51	normal	Bruining (1994)
8	U_{Mv}	Uplift moment about the heel	0.72	0.37	0.51	normal	Bruining (1994)
9	ρ_c	Average density of the caisson (t/m^3)	2.15	0.11	0.05	normal	Burcharth (1994)
10	ψ_1	Angle of dilation rubble mound (rad.)	0.40	0.04	0.10	normal	
11	ψ_2	Angle of dilation sand subsoil (rad.)	0.30	0.03	0.10	normal	
12	φ'_1	Effective friction angle of rubble mound (rad.)	0.73	0.066	0.10	normal	
13	φ'_2	Effective friction angle of sand subsoil (rad.)	0.60	0.06	0.10	normal	
14	Z	Uncertainty of the rupture equation	1	0.10	0.10	normal	Sørensen C.S. (1993)
15	μ_f	Friction factor	0.636	0.0954	0.15	normal	Takayama (1992)

Table 2: Stochastic model of the stochastic variables

In case of a surf zone in front of the structure the breaker height is taken as (Goda, 1994)

$$H_b = L_0 0.17 \left(1 - \exp \left(-1.5 \frac{\pi h_b}{L_0} \left(1 + 15 \tan^{4/3} \theta \right) \right) \right) \quad (12)$$

where h_b is the water depth at a distance $5H_s$ seaward of the structure, and $L_0 = H_{so}/0.035$ is the deepwater wavelength. Consequently, $H_{design} = \min[H_{so}, H_b]$.

Tidal elevation ζ is assumed to follow a cosine distribution function, see Takayama (1992).

$$F_\zeta(\zeta) = -\frac{1}{\pi} \arccos \left(\frac{\zeta}{\zeta_a} - 1 \right) - 1 \quad (13)$$

where ζ varies between $\pm \zeta_a = 0.75$ m.

Storm surge η_s should be considered when the structure is in shallow water, due to possible change in breaker wave heights and buoyancy of the structure. For simplicity the storm surge is not taken into account.

The total water depth in front the structure is $h_{tot} = h_s + \zeta$, where h_s is the mean sea water level at the foot of the structure, without influence from the storm surge or tidal level.

The average mass density of a conventional vertical breakwater including sand ballast, reinforced concrete walls and concrete cap can be assumed to be normal distributed with a mean value in the range $\rho_c = 2.15 - 2.3$ t/m³ and a coefficient of variation of 5%, Burcharth (1992).

It is generally accepted that the variability of the effective friction angle of a well known soil sample is small, but authors such as Nadim et al. (1994) and Cherubini (1992) have encountered variation coefficients in the range 3% to 15%. It is assumed in this paper that the angle of dilation and effective friction angle have a variation coefficient corresponding to 10 %.

The friction coefficient between the base plate and rubble is assumed normal distributed with a mean value $\tan \mu = 0.636$ and a coefficient of variation of 15 %, Takayama (1992).

Even homogeneous soil layers exhibit change in strength from point to point. The undrained shear strength of clay is an example where spatial variability exists. It is assumed to be modelled by a log-Gaussian stochastic field $\{c_u(x, z)\}$ where x is the horizontal coordinate and z the vertical coordinate, see e.g. Andersen et al. (1992). The mean value function and covariance function are in this paper assumed to be

$$E[c_u(x, z)] = \mu_{c_u} + az \quad (14)$$

$$Cov[c_u(x_1, z_1), c_u(x_2, z_2)] = \quad (15)$$

$$\sigma_{c_u}^2 \exp\left(-\left|\frac{z_1 - z_2}{3.0}\right|\right) \exp\left(-\left(\frac{x_1 - x_2}{30.0}\right)^2\right)$$

where c_u is in kPa and x, z are taken in metres with origo $(x, z) = (0, 0)$ equal to point B, see cf. Figure 2, μ_{c_u} is the expected value of the undrained shear strength, σ_{c_u} is the standard deviation of the undrained shear strength and $a = 3 \text{ kPa/m}$ is a constant signifying the linear increase of the undrained shear strength of the clay subsoil.

Method of reliability analysis

The uncertainties (physical, statistical and model) related to the above failure modes cf. Figure 1 are modelled as stochastic variables, and limit state functions for the failure modes are formulated as described above. The wave loads are estimated using the Goda formula, (including impulsive pressure modification) with model uncertainty included. For the foundation failure modes the strength of the clay subsoil is modelled as a stochastic field and a probabilistic limit state function is then formulated using kinematically admissible failure mechanisms, Christiani (1996).

The probability of failure of the failure modes are estimated using First Order Reliability Methods. System failure is modelled by a series system and the system probability of failure can be evaluated on the basis of the FORM analysis of the single failure modes, see Madsen et al. (1986) and Burcharth (1992).

Limit state functions

Sliding failure.

Failure corresponding to sliding can be modelled by the limit state function, cf eq. (1):

$$g_{sliding} = (F_G - F_U) \tan \varphi' - F_H \quad \begin{cases} < 0 & \text{failure} \\ = 0 & \text{limit state} \\ > 0 & \text{no failure} \end{cases} \quad (16)$$

Foundation failure in the rubble and clay subsoil

As mentioned above the undrained shear strength of the clay is modelled as a log-Gaussian stochastic field $\{c_u(x, z)\}$. The correlation lengths for $\{c_u(x, z)\}$ are small compared to the integration intervals and it follows from the central limit theorem that the total internal work in the clay subsoil can be approximated by a normal distributed stochastic variable W_3 with mean value μ_{W_3} and standard deviation σ_{W_3} . The limit state function is written, see eq. (10)

$$g_{clay} = E[W_3] + u_W \sigma_{W_3} - W_{1,2} - W_E \quad (17)$$

where u_W is a realization of a normal distributed stochastic variable U_W with mean 0 and unit standard deviation.

The expected value of W_3 is

$$E[W_3] = \delta R_2^2 \int_0^{2\theta_2} E[c_u(\theta)] d\theta \quad (18)$$

where $E[c_u(\theta)]$ is the expected value of c_u at the position described by the angle θ along the circular rupture line BC.

The variance of W_3 is

$$Var[W_3] = \sigma_{W_3}^2 = \delta^2 R_2^4 \int_0^{2\theta_2} \int_0^{2\theta_2} Cov[c_u(\theta), c_u(\theta_1)] d\theta_1 d\theta \quad (19)$$

where $Cov[c_u(\theta), c_u(\theta_1)]$ is the covariance function of c_u at the positions corresponding to θ and θ_1 .

Systems reliability of the series systems involving sand and clay subsoils

The single failure modes in Figure 1 are regarded as m failure components. It is clear from a deterministic design of a monolithic structure that if one of the failure components fail then the system fails, i.e. the breakwater has no load carrying capacity after the failure of one component. The system probability of failure P_f^s can be written as a probability of unions.

$$P_f^s = P \left(\bigcup_{i=1}^m g_i(\mathbf{x}) \leq 0 \right) = \int_{\bigcup_{i=1}^m g_i(\mathbf{x} \leq 0)} f_{\mathbf{x}}(\mathbf{x}) d\mathbf{x} \quad (20)$$

where $g_i(\mathbf{x})$ is the failure function corresponding to components $i = 1, 2, \dots, m$. The FORM approximation of the generalised systems reliability index β^s can be estimated as:

$$\beta^s = -\Phi^{-1}(1 - \Phi_m(\boldsymbol{\beta}^c, \boldsymbol{\rho})), \quad \text{or} \quad P_f^s = 1 - \Phi_m(\boldsymbol{\beta}^c, \boldsymbol{\rho}) \quad (21)$$

where Φ_m is the m -dimensional standardised normal distribution function, $\boldsymbol{\beta}^c$ is the vector of the reliability indices of the individual failure modes $\boldsymbol{\beta}^c = (\beta_1^c, \beta_2^c, \dots, \beta_m^c)$ and $\boldsymbol{\rho}$ is the correlation coefficient.

If the failure modes are fully correlated then $P_f^s = \max_{i=1}^m P_i$, where $P_i = \Phi(\beta_i^c)$ is the probability of failure for component i . If only failure modes involving foundation failure are considered the correlation coefficients are fairly close to 1. Taking $P_f^s = \max_{i=1}^m P_i$ is then a good approximation, although it is on the unsafe side.

Reliability based optimisation

In design of breakwaters the main objectives are usually to obtain an inexpensive structure and to have a satisfactory structural reliability.

Cost optimal design of a breakwater for construction or rehabilitation is always of interest to the design engineer. An example is presented in the following where the minimum reliability index is fixed and the decision variables are the geometrical values from a cross section of a vertical breakwater cf. Figure 4.

The design (decision) variables are denoted $\mathbf{b} = (b_1, \dots, b_N)$, i.e. the number of design variables is N .

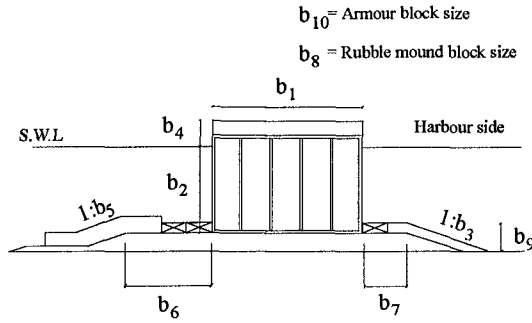

Figure 4: Definition of the design variables for optimal reliability design.

If the objective function is chosen as the total expected costs C_T of the structure during the lifetime, the optimal design can be found as the solution to the optimisation problem

$$\min_{\mathbf{b}} \quad C_T(\mathbf{b}) = C_I(\mathbf{b}) + C_F P_f(\mathbf{b}) \tag{22}$$

$$b_i^l \leq b_i \leq b_i^u \quad , \quad i = 1, \dots, N \tag{23}$$

where b_i^l and b_i^u are lower and upper bounds to b_i . C_I is the initial/construction costs, C_F is the costs of failure, and P_f is the probability of failure during the expected lifetime of the breakwater.

Alternatively an element reliability-index based optimisation problem can be formulated

$$\min_{\mathbf{b}} \quad C_I(\mathbf{b}) \tag{24}$$

$$s.t. \quad \beta_i(\mathbf{b}) \geq \beta_i^{min} \quad , \quad i = 1, \dots, m \tag{25}$$

$$b_i^l \leq b_i \leq b_i^u \quad , \quad i = 1, \dots, N \tag{26}$$

where β_i is the reliability index for failure mode i and β_i^{min} is the corresponding lower bound on the reliability index. Equivalent solutions from (22)-(23) and (24)-(25) can be obtained by suitable choices of β_i^{min} $i = 1, \dots, m$. The above optimisation problems are usually non-linear and non-convex. The optimisation problems can be solved effectively using non-linear optimisation algorithms and FORM.

The reliability indices in (25) are determined on the basis of limit state functions written as $g_i(\mathbf{x}(\mathbf{b}), \mathbf{b}) = 0$, $i = 1, \dots, m$. In a traditional deterministic design the design (optimisation) problem the constraint (25) is exchanged by the deterministic constraint

$$B_i(\mathbf{b}) = g_i(\mathbf{x}^D(\mathbf{b}, \boldsymbol{\gamma}), \mathbf{b}) \geq 0 \quad , \quad i = 1, \dots, m \tag{27}$$

where x^D are design values calculated using the statistical parameters for the stochastic variables X and γ are partial safety factors.

Evaluation of the failure modes

Reliability analysis of an engineering example is performed to show the significance of the failure modes in two series systems involving sand and clay subsoils.

The deterministic design of the vertical breakwater is designed according to Goda's pressure formulation (1974), considering recommended Japanese design guidelines for sliding (safety factor 1.2), overturning (safety factor 1.2) and max heel pressure ($400 - 600 \text{ kN/m}^2$), the tidal elevation $\zeta = 0$ and friction coefficient between base plate and rubble is taken as 0.6 cf. Figure 5.

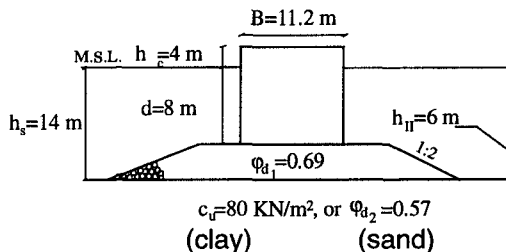

Figure 5: Illustration of a monolithic vertical breakwater.

The sensitivity of the caisson width on the probability of failure considering shoaling and breaker heights in the surf zone is shown in Figure 6

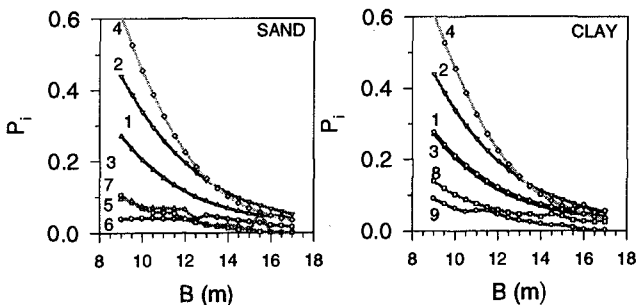

Figure 6: Effect of the width B of the caisson on the probability of failure P_i within 50 year structure lifetime, considering shoaling and breaker heights.

Numbers in the graphs refer to type of foundation failure mechanisms cf. Figure 1. From Figure 6 it is seen that the failure modes (4) and (2) are the most critical failure modes. It is also seen that the probability of failures for the deterministically determined caisson width of 11.2 m are very high.

Optimal design

Optimal design of the example cf. Figure 5 is determined on the basis of the formulation in equations (24) - (26) i.e. the cost of failure is neglected. The initial costs are divided into weight contributions from the rubble mound and the caisson. As design (decision) variables the width (B) and the height (h_{II}) of the rubble mound are chosen.

$$C_I(B, h_{II}) = C_{I_1} \cdot W_{caisson}(B) + C_{I_2} \cdot W_{rubble}(h_{II}) \quad (28)$$

where $W_{caisson}$ is the weight of the caisson and W_{rubble} is the corresponding weight of the rubble. The difference in price per unit weight between the weight of the rubble and caisson is chosen as $\frac{C_{I_1}}{C_{I_2}} = 2$. The cost of construction is minimised with upper bounds on the probability of failure of the significant failure modes.

Optimal designs for different levels of the acceptable probability of failure P_f without considering wave height reduction in the surf zone is presented in Table 3:

Applying Japanese design guidelines	P_f	B (sand & clay), h_{II}	B (sand & clay), h_{II}
$H_s^{90} = 5.56m, B = 17.8m, h_{II} = 6m$	0.1	24.7 (m), 5.0 (m)	26.5 (m), 6.0 (m)
waterdepth at the toe $h_s = 14m$	0.2	20.6 (m), 5.0 (m)	21.6 (m), 6.0 (m)
waterdepth, foot of the caisson $d = 8m$	0.3	18.2 (m), 5.0 (m)	19.0 (m), 6.0 (m)

Table 3: Optimal design for different levels of acceptable probability without considering shoaling and breaker heights in the surf zone.

Conclusions

Foundation failure modes for vertical breakwaters are formulated such that reliability analyses can be performed. The failure modes include sliding failure and failure modes involving sand and clay subsoils. Stochastic models for uncertain parameters are described using the information from experimental tests and from the literature. Further it is mentioned that foundation failure modes can be modelled as components in a series system.

Reliability based optimisation formulations for rational design of vertical wall breakwaters are given. Finally an illustrative example is presented, where the reliability of a breakwater on a high rubble mound is investigated and optimal designs are determined.

Acknowledgements

This work is supported by the Danish research program "Marin Teknik" sponsored by the Danish Technical Research Council.

References

- Andersen, E.Y. & B.S. Andreasen & P. Ostenfeld-Rosenthat (1992). *Foundation Reliability of Anchor Block for Suspension Bridge*. Proc. IFIP WG7.5, Lecture notes in Eng. Vol. 76, Springer Verlag, 1992 pp. 131-140.
- Bruining, J.W. (1994). *Wave forces on vertical breakwaters. Reliability of design formula*. Delft Hydraulics Report H1903, MAST II contract MAS2-CT92-0047.
- Burcharth, H.F. (1991). *Introduction of partial coefficients in the design of rubble mound breakwaters*. Conf.- on Coastal Structures and Breakwaters, Inst. of Civil Engineering, London.
- Burcharth, H.F. (1992a). *Development of a partial coefficient system for the design of rubble mound breakwaters*. PIANC PTC II Working Group 12, Subgroup F report.
- Burcharth, H.F. (1992b). *Reliability evaluation of a structure at sea*. Proceedings of the Short Course on Design and Reliability of Coastal Structures. Venice, Scuola di S. Giovanni Evangelista, 1992. 23rd International Conference on Coastal Engineering.

- Burcharth, H.F. & J.D. Sørensen & E. Christiani (1994). *On the Evaluation of Failure Probability of Monolithic Vertical Wall Breakwaters*. Proc. "Wave Barriers in Deepwater", Port and Harbour Research Institute, Yokosuka, Japan, 1994, pp. 458-46.
- Burcharth H.F., J.D. Sørensen & E. Christiani (1995): *Application of reliability analysis for optimal design of monolithic vertical wall breakwaters*, Proc. COPEDEC 1995, Rio de Janeiro, Brazil.
- Cherubini C. & Giasi C.I. (1993). *The coefficient of variations of some geotechnical parameters*. Probabilistic methods in geotechnical, A.A Balkema (1993).
- Christiani, E. (1996). *Statistically based design methods for breakwaters*. Ph.D., Aalborg University (in print).
- Goda, Y. and T. Fukumori (1972). *Laboratory investigation of wave pressures exerted upon vertical and composite walls*. Coastal Engineering in Japan, Vol. 15. pp 81-90, 1972.
- Goda, Y. (1974). *A new method of wave pressure calculation for the design of composite breakwater*. Proc. 14th Int. Conf. Coastal Eng., Copenhagen, Denmark.
- Goda, Y. (1975). *Irregular wave deformation in the surf zone* Coastal Engineering in Japan, JSCE, Vol.18 pp. 13-16.
- Hansen, B. (1979). *Definition and use of friction angles*. Proc. Int. Conf. VII ECSMFE, Brighton, UK, 1979.
- Nadim, F. & S. Lacasse, and T.R. Cuttormsen (1994). *Probabilistic foundation stability analysis: Mobilised friction angle vs available shear strength approach*. Structural Safety & Reliability, 1994, Balkema, Rotterdam.
- Nielsen S.R.K. and Burcharth H.F. (1983). *Stochastic design of rubble mound breakwaters*. Proc. 11 th IFIP Conference on system modelling and optimization, Copenhagen.
- Madsen, H.O., S. Krenk & N.C. Lind (1986). *Methods of Structural Safety*. Prentice-Hall, 1986.
- Sørensen, J.D., H.F. Burcharth and E. Christiani (1994). *Reliability analysis and optimal design of monolithic vertical wall breakwaters*. Proc. 6th IFIP WG7.5 Assisi, Italy. Chapman & Hall.
- Sørensen, C.S., Clausen, C.J.F., Andersen, H., (1993). *Bearing Capacity Analyses for the Great Belt East Bridge Anchor Blocks. Limit State Design in Geotechnical Engineering*. ISLAD 93, pp. 305-312
- Takahashi, S., Tanimoto, K., and K. Shimosako (1994). *Dynamic Response and Sliding of Breakwater Caisson against Impulsive Breaking Wave forces*. Proc. "Wave Barriers in Deepwater", Port and Harbour Research Institute, Yokosuka, Japan, 1994, pp. 362-399.
- Takayama, T. (1992). *Estimation of sliding Failure Probability of present Breakwaters for Probabilistic Design*. Report of Port and Harbour Research Inst., Vol. 31, No. 5, 1992.