



AALBORG UNIVERSITY
DENMARK

Aalborg Universitet

Advanced Control Architectures for Intelligent MicroGrids, Part I

Decentralized and Hierarchical Control

Guerrero, Josep M.; Chandorkar, Mukul; Lee, Tzung-Lin; Loh, Poh Chiang

Published in:

I E E E Transactions on Industrial Electronics

DOI (link to publication from Publisher):

[10.1109/TIE.2012.2194969](https://doi.org/10.1109/TIE.2012.2194969)

Publication date:

2013

Document Version

Early version, also known as pre-print

[Link to publication from Aalborg University](#)

Citation for published version (APA):

Guerrero, J. M., Chandorkar, M., Lee, T-L., & Loh, P. C. (2013). Advanced Control Architectures for Intelligent MicroGrids, Part I: Decentralized and Hierarchical Control. *I E E E Transactions on Industrial Electronics*, 60(4), 1254-1262 . <https://doi.org/10.1109/TIE.2012.2194969>

General rights

Copyright and moral rights for the publications made accessible in the public portal are retained by the authors and/or other copyright owners and it is a condition of accessing publications that users recognise and abide by the legal requirements associated with these rights.

- Users may download and print one copy of any publication from the public portal for the purpose of private study or research.
- You may not further distribute the material or use it for any profit-making activity or commercial gain
- You may freely distribute the URL identifying the publication in the public portal -

Take down policy

If you believe that this document breaches copyright please contact us at vbn@aub.aau.dk providing details, and we will remove access to the work immediately and investigate your claim.

Advanced Control Architectures for Intelligent MicroGrids – Part I: Decentralized and Hierarchical Control

Josep M. Guerrero, *Senior Member, IEEE*, Mukul Chandorkar, *Member, IEEE*, Tzung-Lin Lee, *Member, IEEE*, and Poh Chiang Loh, *Senior Member, IEEE*

Abstract— This paper presents a review of advanced control techniques for microgrids. The paper covers decentralized, distributed, and hierarchical control of grid connected and islanded microgrids. At first, decentralized control techniques for microgrids are reviewed. Then, the recent developments in the stability analysis of decentralized controlled microgrids are discussed. Finally, hierarchical control for microgrids that mimic the behavior of the mains grid is reviewed.

Index Terms—Microgrids, Hierarchical Control, Distributed Control, Electrical Distribution Networks, Droop Method.

I. INTRODUCTION

THE promise of the smart grid is round the corner. However, research and society cannot wait for the approval of many standards and grid codes, especially when these codes can restrict more the independence of the electricity users from the suppliers. In this sense, the demand side management can be satisfied by using local energy storage and generation systems, thus performing small grids or microgrids. Microgrids should be able to locally solve energy problems, hence increase flexibility and flexibility. Power electronics plays an important role to achieve this revolutionary technology. We can imagine the future grid as a number of interconnected microgrids in which every user is responsible for the generation and storage part of the energy that is consumed, and to share the energy with the neighbors [1].

Hence, microgrids are key elements to integrate renewable and distributed energy resources as well as distributed energy storage systems. In this sense, new power electronic equipment will dominate the electrical grid in the next decades. The trend of this new grid is to become more and more distributed, and hence the energy generation and consumption areas cannot be

conceived separately [5]-[7]. Nowadays electrical and energy engineers have to face a new scenario in which small distributed power generators and dispersed energy storage devices have to be integrated together into the grid. The new electrical grid, also named smart-grid (SG), will deliver electricity from suppliers to consumers using digital technology to control appliances at consumer's homes to save energy, reducing cost and increase reliability and transparency. In this sense, the expected whole energy system will be more interactive, intelligent, and distributed. The use of distributed generation (DG) makes no sense without using distributed storage (DS) systems to cope with the energy balances.

Microgrids, also named minigrids, are becoming an important concept to integrate DG and DS systems. The concept has been developed to cope with the penetration of renewable energy systems, which can be realistic if the final user is able to generate, store, control, and manage part of the energy that will consume. This change of paradigm, allows the final user be not only a consumer but also a part of the grid.

Islanded microgrids have been used in applications like avionic, automotive, marine, or rural areas [2]-[8]. The interfaces between the prime movers and the microgrids are often based on power electronics converters acting as voltage sources (voltage source inverters, VSI, in case of AC-microgrids) [9], [10]. These power electronics converters are parallel connected through the microgrid. In order to avoid circulating currents among the converters without the use of any critical communication between them, the droop control method is often applied [11]-[15].

In case of paralleling inverters, the droop method consist of subtracting proportional parts of the output average active and reactive powers to the frequency and amplitude of each module to emulate virtual inertias. These control loops, also called P - f and Q - E droops, have been applied to parallel-connected uninterruptible power systems (UPS) in order to avoid mutual control wires while obtaining good power sharing [16]-[20]. However, although this technique achieves high reliability and flexibility, it has several drawbacks that limit its application.

For instance, the conventional droop method is not suitable when the paralleled-system must share nonlinear loads, because the control units should take into account harmonic currents, and, at the same time, to balance active and reactive power.

Copyright © 2012 IEEE. Personal use of this material is permitted. However, permission to use this material for any other purposes must be obtained from the IEEE by sending a request to pubs-permissions@ieee.org.

Manuscript received May 27, 2011.

J. M. Guerrero is with the Department of Energy Technology, Aalborg University, 9220 Aalborg East, Denmark (Tel: +45 2037 8262; Fax: +45 9815 1411; e-mail: joz@et.aau.dk).

M. Chandorkar is with the Indian Institute of Technology, Bombay, India.

T.-L. Lee is with the department of electrical engineering, National Sun Yat-sen University, Kaohsiung, Taiwan.

P. C. Loh is with the Nanyang Technological University, Singapore.

Thus, harmonic current sharing techniques have been proposed to avoid the circulating distortion power when sharing nonlinear loads. All of them consist in distorting the voltage to enhance the harmonic current sharing accuracy, resulting in a trade-off. Recently, novel control loops that adjust the output impedance of the units by adding output virtual reactors [17] or resistors [16] have been included into the droop method, with the purpose of sharing the harmonic current content properly. Further, by using the droop method, the power sharing is affected by the output impedance of the units and the line impedances. Hence, those virtual output impedance loops can solve this problem. In this sense, the output impedance can be seen as another control variable.

Besides, another important disadvantage of the droop method is its load-dependent frequency and amplitude deviations. In order to solve this problem, a secondary controller implemented in the microgrid central control can restore the frequency and amplitude in the microgrid.

In this paper, a review of advanced control techniques for microgrids is provided. The paper is organized as follows. In Section II decentralized control techniques for microgrid are reviewed. In Section III recent developments in the stability analysis of decentralized controlled microgrids are discussed. Section IV presents the hierarchical control architecture for microgrids. Finally, Section V presents the conclusions of the paper.

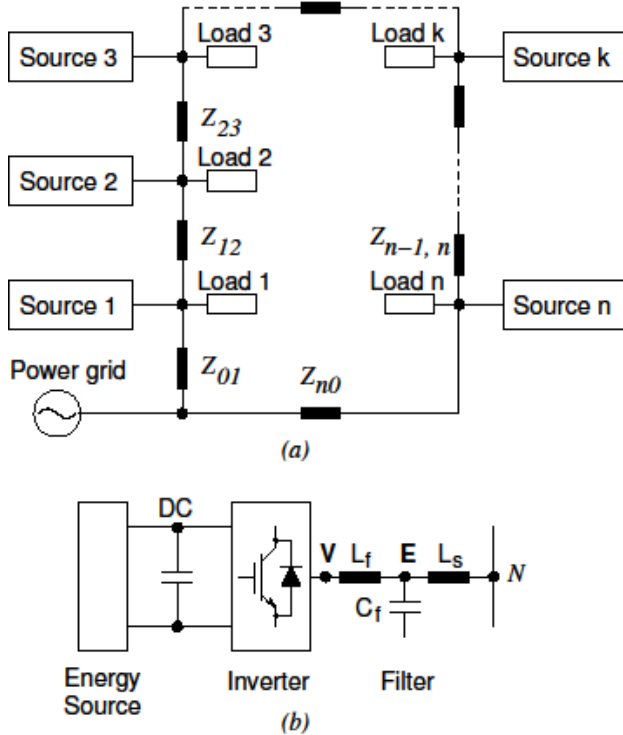

Fig. 1. Microgrid with distributed sources and loads

II. REVIEW OF MICROGRID DECENTRALIZED CONTROL METHODS

The aim of this Section is to review recent work in microgrid decentralized control. The emphasis is on control affecting microgrid dynamic behavior on a relatively fast time scale,

while the issue of load planning and scheduling has been left out of this review.

A key feature of microgrids with distributed energy sources is that the sources are dispersed over a wide area. These sources are interconnected to each other and to loads by a distribution network. Further, the distributed microgrid may be connected to the main power grid at some point as well. Fig. 1(a) shows a distributed microgrid structure connected to the main grid. The figure also shows the microgrid line impedances ($Z_{01}, Z_{12}, \dots, Z_{n-1,n}$). The source is connected to the microgrid distribution network by an inverter interface through a filter, e.g. an *LCL* filter, shown in Fig. 1(b).

The control of the inverter+filter interfaces is crucial to the operation of the microgrid. Because of the distributed nature of the system, these interfaces need to be controlled on the basis of local measurements only; it is not desirable to use data communication. The decentralized control of the individual interfaces should address the following basic issues.

- The interfaces should share the total load (linear or nonlinear) in a desired way.
- The decentralized control based on local measurement should guarantee stability on a global scale.
- The inverter control should prevent any dc voltage offsets on the microgrid.
- The inverter control should actively damp oscillations between the output filters.

From the viewpoint of decentralized control, it is convenient to classify distributed generation architectures into three classes with respect to the interconnecting impedances Z_{01} etc., shown in Fig. 1(a). In highly dispersed networks, the impedances are predominantly inductive and the voltage magnitude and phase angle at different source interconnects can be very different. In networks spread over a smaller area, the impedances are still inductive but also have a significant resistive component. The voltage magnitude does not differ much, but the phase angles can be different for different sources. In very small networks, the impedance is small and predominantly resistive. Neither magnitude nor phase angle differences are significant at any point. In all cases, the main common quantity is the steady-state frequency which must be the same for all sources. In the grid-connected mode, the microgrid frequency is decided by the grid. In the islanded mode, the frequency is decided by the microgrid control.

In each of these classes, if every source is connected to at most two other sources as shown in Fig. 1(a), then the microgrid is *radial*. Otherwise, it is *meshed*. If there is a line connecting Source 1 with Source k in Fig. 1(a), then it is a meshed microgrid. By far the largest body of research work done in decentralized microgrid control has been for radial architectures of the type described in [1].

Early work on decentralized parallel inverter control concepts suitable for microgrid operation was reported in [2]. This work assumed that the impedance connecting sources was predominantly inductive; resistance was neglected. Based on the decentralized control used in conventional power systems, the use of droops is introduced in the generators, hence adjusting the frequency set-point according to the output active power, and voltage magnitude set-point depending on the output reactive power. It was shown that the distributed system

could be operated without the use of phase-locked loops (PLLs), and that total load real- and reactive-power could be shared based on the converter ratings.

Subsequent work [3], [4] extended the droop concept to ensure sharing of harmonic currents of non-linear loads. This was done by extending the droop concept by making the sources inject control signals into the network at a frequency which droops as the shared quantity increases. PLLs in remote units extract this information and adjust their output. Although interesting, this approach has not yet been investigated fully to study the issues of voltage distortion and noise immunity.

In further investigation of the droop concept, some researchers [5]-[7] have proposed power-angle droop control, in which the phase angle of the distributed source voltage, relative to a system-wide common timing reference, is set according to a droop law. One possible source for the common timing reference is the Global Positioning System (GPS). The GPS provides a 1-pulse-per-second (1PPS) signal [8], the rising edge of which is simultaneous globally to within $1 \mu\text{s}$. The 1PPS signal can be used to synchronize local clocks in the distributed sources. The local clock is used to generate the timing reference with which the output voltage phase is measured. An alternative, in the near future, to the GPS clock signal may be an implementation of the Precision Time Protocol (PTP), defined in IEEE Standard 1588-2008 [9]. Angle control has the advantage that power sharing can be achieved without a change in the system frequency during islanded operation. No communication is needed between sources. However, those issues of system stability, loss of the global synchronizing signal at a few units, fallback to power-frequency droop operation, and grid-interactive operation need to be explored further.

Droop-based control methods have a drawback: in the islanded mode, the voltage and frequency of the microgrid change with change in load. Steeper droops ensure better load sharing, but also result in larger frequency and voltage deviations. If it is intended that microgrid sources conform to IEEE Standard 1547-2003 [10], then there should be a mechanism to restore the system frequency and voltage to nominal values following a load change [11], [12]. Following the term used in electric power system control, this restoration mechanism is termed as *secondary control* of voltage and frequency, and takes place over a longer time scale. In this regard, in addition to decentralized control, several researchers have considered the use of low-bandwidth communication channels between source controllers for the secondary control functions of restoration, load sharing and management [13]-[15].

Researchers have also recognized that the conventional frequency- and voltage-droop methods proposed in earlier work have limitations when the microgrid interconnecting impedances have a significant resistive component [16]-[23]. In this situation, the active power vs. frequency droop (P - f droop) and the reactive power vs. voltage droop (Q - E droop), taken from conventional power system control practice, are not valid. Thus, the real power is affected more by voltage magnitude and the reactive power is affected more by phase angle difference [16], [17]. The droop controller is modified accordingly for resistive impedance, obtaining P - E and Q - f droops.

There are two main approaches to addressing the effect of the interconnecting line impedance on droop based control. The first approach decouples the voltage and frequency droop controls by analyzing and compensating for the effect of the line impedance on active and reactive power flows. The second approach introduces virtual impedance at the converter output through closed loop converter control.

The authors of [20] adopt the first approach. They report the way in which frequency and voltage influence active and reactive power for different inductance to resistance ratios of the interconnecting line. They propose a way to decouple the frequency and voltage control droops by the use of a reference frame transformation that depends on knowledge of the line reactance to resistance ratio.

The second approach to addressing the line impedance issue is presented in [16], in which virtual resistive output impedance is introduced by modifying the output voltage reference based on output current feedback. With resistive impedance, the voltage and frequency droop controllers are decoupled.

The use of inductive virtual impedance at the converter output is reported in [22]. Output current feedback is used to implement a controller that presents a virtual inductor at the converter output. The frequency and voltage droops are decoupled with a virtual inductor at the output, and the conventional droop schemes can be used.

The virtual impedance method has the advantage over the decoupling method in that it is insensitive to the nature of the line impedance [16]. Thus, an overall decentralized control strategy could include virtual impedance control in conjunction with droops, and secondary control to restore the system frequency and voltage [19].

It is worth noting that the majority of work done on microgrid decentralized control has been for radial microgrid topologies. The decentralized control of interfaces in meshed topologies is

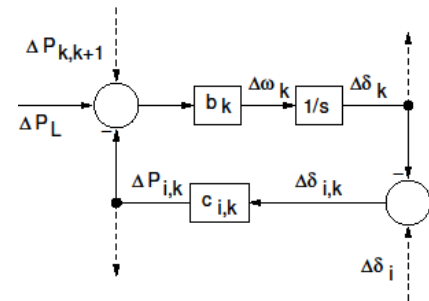

Fig. 2. Radial microgrid power-frequency droop control: small-signal behavior

an area that needs further research.

III. STABILITY ANALYSIS OF DECENTRALIZED CONTROLLED MICROGRIDS

Stability is a critical issue in a microgrid in which the source power electronic interfaces are controlled in a decentralized way. Each interface is controlled based only on local measurement, and so it is important to analyze how the individual control systems interact to ensure overall stability. In this regard, if a steady state can be reached in which the fundamental components of all voltages in the microgrid have constant amplitudes and constant relative phase angle

differences, then the system is stable. In this section we review results of microgrid stability analysis, and also present recent results in the testing of decentralized controllers.

By far the largest body of work done in microgrid stability analysis is for radial microgrids. Stability studies for meshed microgrids have still not been reported significantly in the literature, and are an open research area.

Stability analysis studies typically assume that frequency deviations are small even transiently, so that all impedances in the network can be assumed constant. This assumption results in a significant simplification in the analytical formulation of microgrid stability.

Early work towards a generalized approach for analyzing the small-signal stability of interconnected inverter systems was reported in [24]. This was reported for a radial architecture with inductive line impedances, inverters controlled by power-frequency droops, constant output voltage amplitude, and fast response of the inner voltage control loop. It was shown that such a system is always small-signal stable regardless of the number of interfaces, and has only non-oscillatory response to load changes. The control interconnections for such a system are shown in Fig. 2. In this figure, i and k are indices for the parallel inverters in the radial system. The constant b is the droop value, and the constant c depends on the voltage magnitude and line impedance. $\Delta\delta$ is a small change in the voltage phase angle from its nominal value, and ΔP is a small change in power flow from its nominal value. It was also shown that large values of the power-frequency droops violate the condition on the inner voltage control loop, and the network becomes unstable.

This result was extended in [25] with the inclusion of reactive power-voltage magnitude droops for the interface inverters. While the inner voltage control loop dynamics were ignored, a frequency restoration controller was included in the small-signal stability analysis. The authors showed that a radial microgrid with inductive interconnects is small-signal stable in the presence of both, frequency and voltage droops. The studies of [24] and [25] show that a radial microgrid with inductive interconnecting impedances, having fast voltage control loops, and controlled by frequency and voltage droops, will always be small-signal stable for reasonable values of droop gains, regardless of the microgrid size.

Recognizing that the nominal operating point used for small-signal analysis changes with change in frequency and voltage in a microgrid, the authors of [26] investigate the dependence of the small-signal stability on the operating point. The authors propose a method, based on the operating point, to set droop gains adaptively. However, the analysis is limited to a system with three sources.

Further investigation of the effect of droop gains on microgrid stability margin is carried out in [27]. Rather than changing the droop gains constantly depending on the operating point, the authors suggest the use of limit cases to set limits on the values of the droop gains. The limit cases are constructed off-line, based on knowledge of the microgrid structure. The authors present cases that achieve acceptable transient behavior with acceptable stability margins. A radial microgrid structure is assumed.

An interesting case study of small-signal modeling of a microgrid that is supplied by both, a synchronous generator and

an inverter-interfaced energy source, is presented in [28]. The generator electromechanical model and the excitation system model are linearized about an operating point. The inverter and its control are similarly modeled and linearized. The combined linearized model can be used for small-signal stability studies. However, while the study is limited to two distributed sources, it is not clear how the approach can be scaled to address small-signal stability of larger systems.

A computational approach to determining microgrid stability, scalable to large systems, is presented in [29]. The approach considers the overall stability as affected by the droop control gains. Scalability is achieved by model order reduction. Using a three-inverter radial microgrid as a test case, the authors show that high values of frequency droop gains compromise the stability of the overall microgrid, but voltage droop gains do not have a significant effect on stability. Another scalable, computational approach to microgrid modeling is given in [29] and [30]. This approach uses the Automated State Model Generation algorithm proposed in [31] to develop the microgrid transient model systematically. The model can then be used either as part of a transient simulation program to study large-signal behavior, or as part of a computational program to study small-signal stability. While most stability studies have considered radial microgrid topologies, we feel that computational approaches such as in [30] may be very suitable for the stability studies of meshed topologies.

An important aspect of proving microgrid stability in specific cases is to have the ability to test microgrid controllers in real-time hardware-in-loop (HIL) simulation. An example of this testing is provided in [23] and [32] in which the microgrid dynamics are simulated on a real-time digital simulator, and the controller is interfaced to the simulator. Both [23] and [32] report the use of a commercial real-time simulator to implement the microgrid model.

IV. HIERARCHICAL CONTROL OF MICROGRIDS

Microgrids are now in the cutting edge of the state of the art [1]. However, the control and management of such a systems needs still further investigation. Microgrids for standalone and grid-connected applications have been considered in the past as separated approaches. Nevertheless, nowadays is necessary to conceive flexible microgrids able to operate in both grid-connected and islanded modes [19]. Thus, the study of topologies, architectures, planning, and configurations of microgrids are necessary. This is a great challenge due to the need of integrating different technologies of power electronics, telecommunications, generation and storage energy systems, among others. In addition, islanding detection algorithms for microgrids are necessary for ensuring a smooth transition between grid-connected and islanded modes. Furthermore, security issues such as fault monitoring, predictive maintenance, or protection are very important regarding microgrids feasibility.

This section deals with the hierarchical control of microgrids, consisted in three control levels. UCTE (Union for the Co-ordination of Transmission of Electricity, Continental Europe) have defined a hierarchical control for large power systems, as shown in Fig. 3. In such a kind of systems, it is

supposed to operate over large synchronous machines with high inertias and inductive networks. However, in power electronic based microgrids there are no inertias and the nature of the networks is mainly resistive, as discussed in Section II. Consequently there are important differences between both systems that we have to take into account when designing their control schemes. This three-level hierarchical control is organized as follows [48]. The primary control deals with the inner control of the DG units by adding virtual inertias and controlling their output impedances. The secondary control is conceived to restore the frequency and amplitude deviations produced by the virtual inertias and output virtual impedances. The tertiary control regulates the power flows between the grid and the microgrid at the point of common coupling (PCC).

A. Inner control loops

The use of intelligent power interfaces between the electrical generation sources and the microgrid is mandatory. These interfaces have a final stage consisting of dc/ac inverters, which can be classified in current-source inverters (CSIs), consisted of an inner current loop and a PLL to continuously stay synchronized with the grid, and voltage-source inverters (VSIs), consisted of an inner current loop and an external voltage loop. In order to inject current to the grid, CSIs are commonly used, while in island or autonomous operation, VSIs are needed to keep the voltage stable.

VSIs are very interesting for microgrid applications since they do not need any external reference to stay synchronized. Furthermore, VSIs are convenient since they can provide to distributed power generation systems performances like ride-through capability and power quality enhancement. When these inverters are required to operate in grid-connected mode, they often change its behavior from voltage to current sources. Nevertheless, to achieve flexible microgrid, i.e., able to operate in both grid-connected and islanded modes, VSIs are required to control the exported or imported power to the mains grid and to stabilize the microgrid [19].

VSIs and CSIs can cooperate together in a microgrid. The VSIs are often connected to energy storage devices, fixing the frequency and voltage inside the microgrid. The CSIs are often connected to photovoltaic (PV) or small wind-turbines (WT) that require for maximum power point tracking (MPPT) algorithms, although those DG inverters could also work as VSIs if necessary. Thus, we can have a number of VSIs and CSIs, or only VSIs, connected in parallel forming a microgrid.

B. Primary control

When connecting two or more VSIs in parallel, circulating active and reactive power can appear. This control level adjusts the frequency and amplitude of voltage reference provided to the inner current and voltage control loops. The main idea of this control level is to mimic the behavior of a synchronous generator, which reduces the frequency when the active power increases. This principle can be integrated in VSIs by using the well known P/Q droop method [2]:

$$f = f^* - G_p(s) \cdot (P - P^*) \quad (1)$$

$$E = E^* - G_Q(s) \cdot (Q - Q^*) \quad (2)$$

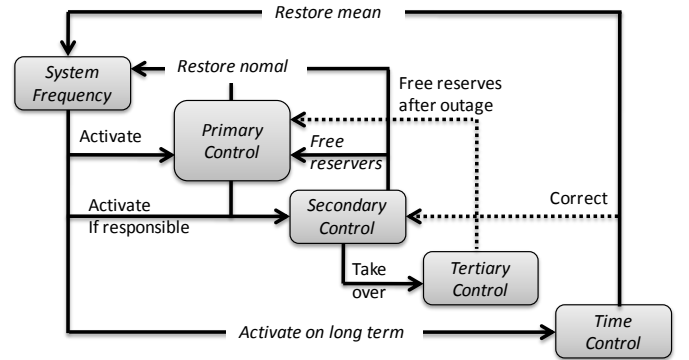

Fig. 3. Frame for the multilevel control of a power system, defined by UCTE.

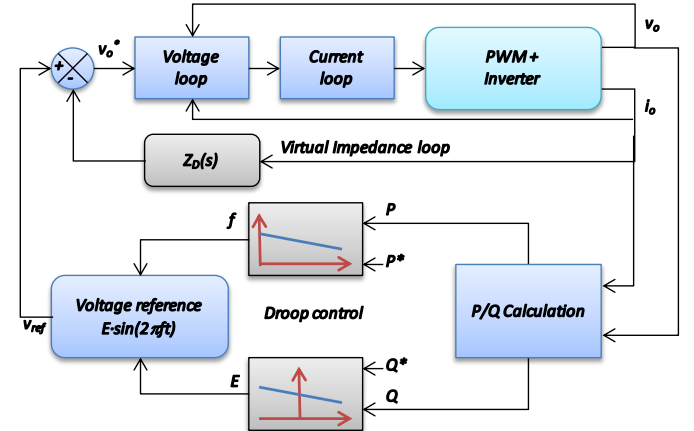

Fig. 4. Primary control: Droop control with virtual impedance, and inner control loops applied to an inverter.

being f and E the frequency and amplitude of the output voltage reference, f^* and E^* their references, P and Q the active and reactive power, P^* and Q^* their references, and $G_p(s)$ and $G_Q(s)$ their corresponding transfer functions, which are typically proportional droop terms, i.e. $G_p(s) = m$ and $G_Q(s) = n$. Note that the use of pure integrators is not allowed when the microgrid is in island mode, since the total load will not coincide with the total injected power, but they can be useful in grid connected mode to have a good accuracy of the injected P and Q . Nevertheless, this control objective will be achieved by the tertiary control level.

The design of $G_p(s)$ and $G_Q(s)$ compensators can be done by using different control synthesis techniques. However, the DC gain of such a compensators (named m and n) provide for the static $\Delta P/\Delta f$ and $\Delta Q/\Delta V$ deviations, which are necessary to keep the system synchronized and inside the voltage stability limits. Those parameters can be designed as follows:

$$m = \Delta f / P_{max} \quad (3)$$

$$n = \Delta V / 2Q_{max} \quad (4)$$

being Δf and ΔV the maximum frequency and voltage allowed, and P_{max} and Q_{max} the maximum active and reactive power delivered by the inverter. If the inverter can absorb active power, since it is able to charge batteries like a line-interactive UPS, then $m = \Delta f / 2 P_{max}$.

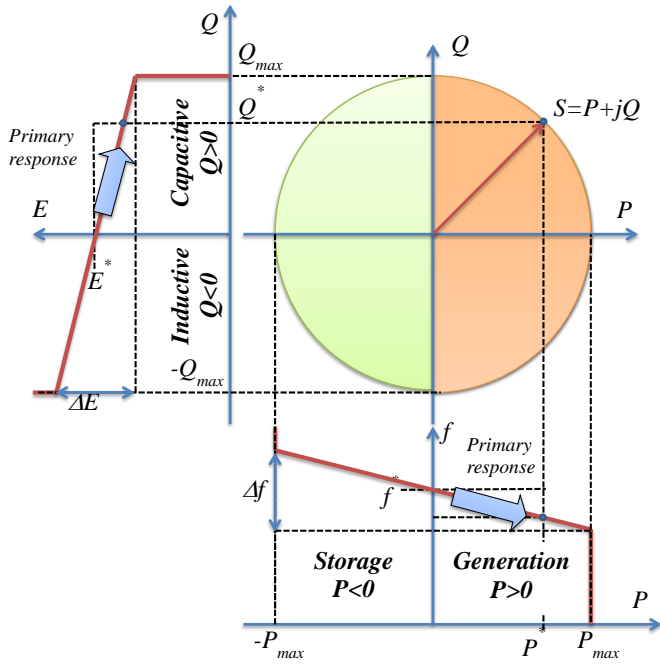

Fig. 5. P - Q circle and P - f and Q - E droop primary control relationship.

Fig. 5 shows the relationship between the P - Q circle of a DG unit and P - f and Q - E droops. Notice that in that case, the DG is able to generate active power ($P > 0$) and to store energy ($P < 0$), and, at the same time, is able to supply reactive power ($Q > 0$, acting like a capacitor) or to absorb reactive power ($Q < 0$, acting like an inductor).

In the conventional droop method used by large power systems, it is supposed that the output impedance of synchronous generators as well as the line impedance is mainly inductive. However, when using power electronics the output impedance will depend on the control strategy used by the inner control loops. Further, the line impedance in low voltage applications is near to be pure resistive. Thus the control droops (1) and (2) can be modified according to the park transformation determined by the impedance angle θ [18]:

$$f = f^* - G_P(s) \left[(P - P^*) \sin \theta - (Q - Q^*) \cos \theta \right] \quad (5)$$

$$E = E^* - G_Q(s) \left[(P - P^*) \cos \theta + (Q - Q^*) \sin \theta \right] \quad (6)$$

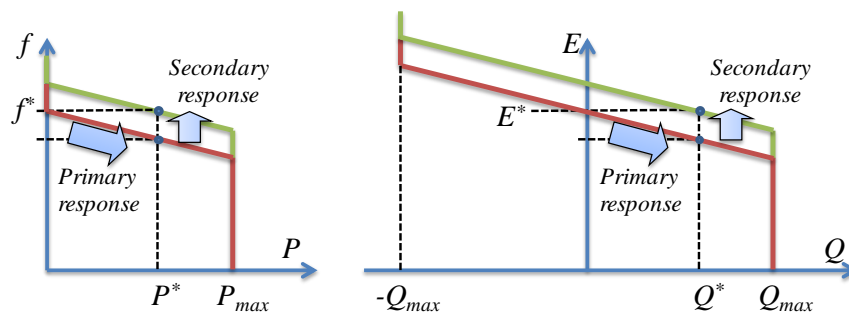

Fig. 6. P - f and Q - E primary and secondary control actions.

The primary control level can also include the virtual output impedance loop, in which the output voltage can be expressed as [16]:

$$v_o^* = v_{ref} - Z_D(s) \cdot i_o \quad (7)$$

where v_{ref} is the voltage reference generated by equations (5)-(6) being $v_{ref} = E \sin(2\pi f t)$, and $Z_D(s)$ is the virtual output impedance transfer function, which normally ensures inductive behavior at the line-frequency. Fig. 4 depicts the virtual impedance loop in relation with the other control loops: inner current and voltage loops, and the droop control. Usually the virtual impedance Z_D is designed to be bigger than the output impedance of the inverter plus the line impedance, this way the total equivalent output impedance is mainly dominated by Z_D [16]. The virtual output impedance Z_D is equivalent to the series impedance of a synchronous generator. However, although the series impedance of a synchronous generator is mainly inductive, the virtual impedance can be chosen arbitrarily. In contrast with a physical impedance, this virtual output impedance has no power losses, thus it is possible to implement resistance without efficiency losses.

Notice that by using the virtual impedance control loop, the inverter output impedance becomes a new control variable. Thus, we can adjust the phase angle of equations (6)-(7) according to the expected X/R ratio of the line impedance, $\theta = \tan^{-1} X/R$, and the angle of the output impedance at the line frequency. Furthermore, the virtual output impedance can provide additional features to the inverter, such as hot-swap operation and harmonic current sharing [17]-[18]. These control loops allows the parallel operation of the inverters. However, those have an inherent trade of between P/Q sharing and frequency/amplitude regulation [16]-[19].

A. Secondary control

In order to compensate for the frequency and amplitude deviations, a secondary control can be used. The secondary control ensures that the frequency and voltage deviations are regulated towards zero after every change of load or generation inside the microgrid. The frequency and amplitude levels in the microgrid f_{MG} and E_{MG} are sensed and compared with the references f_{MG}^* and E_{MG}^* the errors processed through compensators (δf and δE) are send to all the units to restore the output voltage frequency and amplitude.

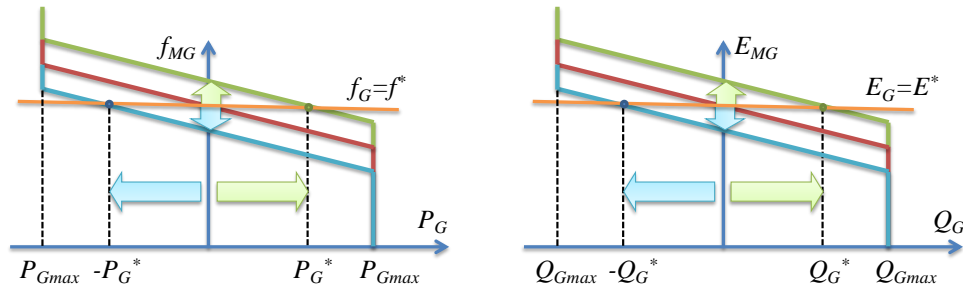

Fig. 7. $f-P$ and $E-Q$ tertiary control actions.

The secondary control is used in power systems correct the grid frequency deviation within allowable limit, e.g. ± 0.1 Hz in Nordel (North of Europe) or ± 0.2 Hz in UCTE (Union for the Co-ordination of Transmission of Electricity, Continental Europe). It consists of a PI-type controller, also called Load-Frequency Control (LFC) in Europe or Automatic Gain Controller (AGC) in USA. In case of an AC-microgrid, the frequency and amplitude restoration controllers, G_f and G_E , can be obtained similarly as follows:

$$\delta f = k_{pf} (f_{MG}^* - f_{MG}) + k_{if} \int (f_{MG}^* - f_{MG}) dt + \Delta f_s \quad (8)$$

$$\delta E = k_{pE} (E_{MG}^* - E_{MG}) + k_{iE} \int (E_{MG}^* - E_{MG}) dt \quad (9)$$

being k_{pf} , k_{if} , k_{pE} , and k_{iE} the control parameters of the secondary control compensator, and Δf_s is a synchronization term which remains equal to zero when the grid is not present. In this case, δf and δE must be limited in order to do not exceed the maximum allowed frequency and amplitude deviations.

Fig. 6 depicts the primary and secondary control action over the $P-f$ and $Q-E$ characteristics. This way, the frequency and amplitude restoration process is done by the secondary control in a droop controlled microgrid when increasing the P and Q demanded. Notice that without this action, both frequency and amplitude of the microgrid are load-dependent.

B. Tertiary control

When the microgrid is operating in grid-connected mode, the power flow can be controlled by adjusting the frequency (changing the phase in steady state) and amplitude of the voltage inside the microgrid [19]. By measuring the P/Q at the PCC, P_G and Q_G , they can be compared with the desired P_G^* and Q_G^* , and controlled as following:

$$f_{MG}^* = k_{pP} (P_G^* - P_G) + k_{iP} \int (P_G^* - P_G) dt \quad (10)$$

$$E_{MG}^* = k_{pQ} (Q_G^* - Q_G) + k_{iQ} \int (Q_G^* - Q_G) dt \quad (11)$$

being k_{pP} , k_{iP} , k_{pQ} , and k_{iQ} the control parameters of the tertiary control compensator. Here, f_{MG}^* and E_{MG}^* are also saturated in case of being outside of the allowed limits. This variables are inner generated in island mode ($f_{MG}^* = f_i^*$ and $E_{MG}^* = E_{MG}^*$), by the secondary control. When the grid is present, the synchronization process can start, and f_{MG}^* and E_{MG}^* can be equal of those measured in the grid. Thus, the frequency and amplitude references of the microgrid will be the frequency and amplitude of the mains grid. After the synchronization, these signals can be given by the tertiary control (10)-(11).

Notice that, depending on the sign of P_G^* and Q_G^* , the active and reactive power flows can be exported or imported independently. Fig. 7 shows the tertiary control action, which is responsible of interchange P and Q at the PCC, the power flow bidirectionality of the microgrid can be observed. The grid have constant frequency and amplitudes ($f_G = f^*$ and $E_G = E^*$), so that it is represented by horizontal lines. Thus, the amount of P and Q exchanged between the microgrid and the grid (P_G and Q_G) are determined by the intersection of the droop characteristics of the microgrid and the horizontal lines of the grid. Consequently, P_G can be controlled by adjusting the microgrid reference frequency f_{MG}^* as follows. If $f_{MG}^* > f_G$ then $P_G > 0$, and the microgrid injects P to the grid; while if $f_{MG}^* < f_G$ then $P_G < 0$ thus the microgrid absorbs P from the grid. The frequency of the microgrid will be determined by the grid, so that this action will result in a change of the power angle. Similar analysis can be done for the reactive power Q_G .

Furthermore, in (8) and (9), by making k_{iP} and k_{iQ} equal to zero, the tertiary control will act as a primary control of the microgrid, thus allowing the interconnection of multiple microgrid, forming a cluster. Hence, this control loop also can be used to improve the power quality at the PCC. In order to achieve voltage dips ride-through, the microgrid must inject reactive power to the grid, thus achieving inner voltage stability. Particularly, if we set $k_{iQ} = 0$, the microgrid will inject automatically Q when there is a voltage sag or absorb reactive power when there is a swell in the grid. This can endow to the microgrid low-voltage ride-through (LVRT) capability. In Part II of this paper will be introduced the implementation of this capability by means of a dedicated power converter [33].

Islanding detection is also necessary to disconnect the microgrid from the grid and disconnect both the tertiary control references as well as the integral terms of the reactive power PI controllers, to avoid voltage instabilities. When a non-planned islanding scenario occurs, the tertiary control tries to absorb P from the grid, so that as the grid is not present, the frequency will start to decrease. When it goes out from the expected values, the microgrid is disconnected from the grid for safety and the tertiary control is disabled.

V. CONCLUSIONS

We have reviewed the current status of microgrid decentralized control and methods to analyze and assess microgrid stability. We have also considered the issue of in-situ decentralized testing of microgrid controllers.

Time-synchronization techniques such as the GPS timing signal and the PTP are very likely to play a significant role in both, microgrid control and controller testing. Similarly, advances in numerical techniques that assess conventional power system stability are also likely to play a role in microgrids as well.

The future trends in hierarchical control for microgrids are essentially related to energy management systems (EMS), giving references from and to the tertiary control in order to optimize the efficiency of the microgrid. Another important issue will be the clusters of microgrids, which are expected to be developed in near future by interconnecting intelligent microgrids. Each microgrid will have a number of Energy Services, such as active/reactive power demand/generation, storage capability, and so on, which could be of mutual interest among microgrids. Thus multi-agents could negotiate the interchange of energy between microgrids or microgrid clusters. Being multi-agents and hierarchical control a clear trend of research in microgrids, technologies like communication systems are becoming important to make feasible these applications.

Finally, more industrial applications will push the research in this area after the recent final approval of the Standard IEEE 1547.4, which allows microgrids to operate in island under certain conditions [32]. This Standard constitutes a clear breakthrough toward new codes and industrial equipment that will need for extra functionalities required by the microgrid operations.

REFERENCES

- [1] R.H. Lasseter, "Microgrids", in *Proc. IEEE PES Winter Meeting 2002*, pp. 305-308.
- [2] M. Chandorkar, D. Divan, and R. Adapa, "Control of parallel connected inverters in standalone ac supply systems", *IEEE Trans. Ind. Appl.*, vol. 29, no. 1, pp. 136-143, Jan./Feb. 1993.
- [3] A. Tuladhar, H. Jin, T. Unger, and K. Mauch, "Operation of single phase inverter modules with no control interconnections", in *Proc. IEEE APEC 1997*, pp. 94-100.
- [4] A. Tuladhar, H. Jin, T. Unger, and K. Mauch, "Control of parallel inverters in distributed ac power systems with consideration of line impedance effect", *IEEE Trans. Ind. Appl.*, vol. 36, no. 1, pp. 131-138, Jan./Feb. 2000.
- [5] R. Majumder, A. Ghosh, G. Ledwich, and F. Zare, "Angle droop versus frequency droop in a voltage source converter based autonomous microgrid", in *Proc. IEEE PES General Meeting 2009*.
- [6] R. Majumder, B. Chaudhuri, A. Ghosh, R. Majumder, G. Ledwich, and F. Zare, "Improvement of stability and load sharing in an autonomous microgrid using supplementary droop control loop", *IEEE Trans. Power Systems*, vol. 25, no. 2, pp. 796-808, May 2010.
- [7] R. Majumder, A. Ghosh, G. Ledwich, and F. Zare, "Load sharing and power quality enhanced operation of a distributed microgrid", *IET Renew. Power Gener.*, vol. 3, no. 2, pp. 109-119, 2009.
- [8] G. J. Geier, T.M. King, H.L. Kennedy, R.D. Thomas, and B.R. McNamara, "Prediction of the time accuracy and integrity of GPS timing", in *Proc. IEEE International Frequency Control Symposium*, 1995, pp. 266-274.
- [9] *IEEE Standard for a Precision Clock Synchronization Protocol for Networked Measurement and Control Systems*, IEEE Standard 1588-2008.
- [10] *IEEE Standard for Interconnecting Distributed Resources with Electric Power Systems*, IEEE Standard 1574-2003.
- [11] M.C. Chandorkar and D.M. Divan, "Decentralized Operation of Distributed UPS Systems", in *Proc. IEEE PEDES 1996*, pp. 565-571.
- [12] F. Katiraei and M.R. Iravani, "Power management strategies for a microgrid with multiple distributed generation units", *IEEE Trans. Power Systems*, vol. 21, no. 4, pp. 1821-1831, Nov. 2006.
- [13] M. Prodanovic and T.C. Green, "High-quality power generation through distributed control of a power park microgrid", *IEEE Trans. Ind. Electron.*, vol. 53, no.5, pp. 1471-1482, October 2006.
- [14] M. N. Marwali, J.-W. Jung, and A. Keyhani, "Control of distributed generation systems – part II: load sharing control", *IEEE Trans. Power Electron.*, vol. 19, no. 6, pp. 1551-1561, Nov. 2004.
- [15] A. Mehrizi-Sani and R. Iravani, "Potential function based control of a microgrid in islanded and grid-connected modes", *IEEE Trans. Power System*, vol. 25, no.4, pp. 1883-1891, Nov. 2010.
- [16] J.M. Guerrero, J. Matas, L.G. de Vicuña, M. Castilla, and J. Miret, "Decentralized control for parallel operation of distributed generation inverters using resistive output impedance", *IEEE Trans. Ind. Electron.*, vol. 54, no. 2, pp. 994-1004, April 2007.
- [17] J.M. Guerrero, J. Matas, L.G. de Vicuña, M. Castilla, and J. Miret, "Output impedance design of parallel-connected UPS inverters with wireless load-sharing control", *IEEE Trans. Ind. Electron.*, vol. 52, no. 4, pp. 1126-1135, August 2005.
- [18] J.M. Guerrero, J. Matas, L.G. de Vicuña, M. Castilla, and J. Miret, "Wireless-control strategy for parallel operation of distributed-generation inverters", *IEEE Trans. Ind. Electron.*, vol. 53, no. 5, pp. 1461-1470, October 2006.
- [19] J.M. Guerrero, J.C. Vásquez, J. Matas, M. Castilla, and L.G. de Vicuña, "Control Strategy for flexible microgrids based on parallel line-interactive UPS systems", *IEEE Trans. Ind. Electron.*, vol. 56, no. 3, pp. 726-735, August 2009.
- [20] K. D. Brabandere, B. Bolsens, J. V. D. Keybus, A. Woyte, J. Driesen, and R. Belmans, "A voltage and frequency droop control method for parallel inverters," *IEEE Trans. Power Electron.*, vol. 22, no. 4, pp. 1107-1115, Jul. 2007.
- [21] C.-T. Lee, C.-C. Chuang, C.-C. Chu, and P.-T. Cheng, "Control strategies for distributed energy resources interface converters in low voltage microgrid", in *Proc. IEEE ECCE 2009*, pp. 2022-2029.
- [22] Y. W. Lee, and C.-N. Kao, "An accurate power control strategy for power-electronics-interfaced distributed generation units operating in a low-voltage multibus microgrid", *IEEE Trans. Power Electron.*, vol. 24, no. 12, pp. 2977-2988, December 2009.
- [23] X. Yu, A.M. Khambadkone, H. Wang, and S.T.S. Terence, "Control of parallel-connected power converters for low-voltage microgrid – Part I: a hybrid control architecture", *IEEE Trans. Power Electron.*, vol. 25, no. 12, pp. 2962-2970, December 2010.
- [24] M.C. Chandorkar, *Distributed uninterruptible power supply systems*, Ph.D. dissertation, University of Wisconsin-Madison, 1995.
- [25] G. Venkataramanan and M. Illindala, "Small signal dynamics of inverter interfaced distributed generation in a chain-microgrid", in *Proc. IEEE PES General Meeting*, 2007.
- [26] Y. Mohamed and E.F. El-Saadany, "Adaptive decentralized droop controller to preserve power sharing stability of paralleled inverters in distributed generation microgrids", *IEEE Trans. Power Electron.*, vol. 23, no. 6, pp. 2806-2816, Nov. 2008.
- [27] E. Barklund, N. Pogaku, M. Prodanovic, C. Hernandez-Aramburo, and T.C. Green, "Energy management in autonomous microgrid using stability-constrained droop control of inverters", *IEEE Trans. Power Electron.*, vol. 23, no. 5, pp. 2346-2352, Sep. 2008.
- [28] F. Katiraei, M.R. Iravani, and P.W. Lehn, "Small-signal dynamic model of a micro-grid including conventional and electronically interfaced distributed resources", *IET Gener. Transm. Distrib.*, vol. 1, no. 3, pp. 369-378, May 2007.
- [29] S.V. Iyer, M.N. Belur, and M.C. Chandorkar, "A generalized computational method to determine stability of a multi-inverter microgrid", *IEEE Trans. Power Electron.*, vol. 25, no. 9, pp. 2420-2432, Sept. 2010.
- [30] B.B. Johnson, A. Davoudi, P.L. Chapman, and P. Sauer, "Microgrid dynamics characterization using the Automated State Model Generation Algorithm", in *Proc. IEEE Circuits and Systems (ISCAS) 2010*, pp. 2758-2761.
- [31] O. Wasynczuk, S.D. Sudhoff, "Automated state model generation algorithm for power circuits and systems", *IEEE Trans. Power Systems*, vol. 11, no. 4, pp. 1951-1956.
- [32] IEEE Guide for Design, Integration, and Operation of Distributed Resource Island Systems with Electric Power Systems, IEEE Standard 1547.4.2011, 2011.



Josep M. Guerrero (S'01–M'03–SM'08) was born in Barcelona, Spain, in 1973. He received the B.S. degree in telecommunications engineering, the M.S. degree in electronics engineering, and the Ph.D. degree in power electronics from the Technical University of Catalonia, Barcelona, Spain, in 1997, 2000 and 2003, respectively. He has been an Associate Professor with the Department of Automatic Control Systems and Computer Engineering, Technical University of Catalonia, Barcelona, teaching courses on digital signal processing, FPGAs, microprocessors, and control of renewable energy. Since 2004, he has been responsible for the Renewable Energy Laboratory, Escola Industrial de Barcelona. He has been a visiting Professor at Zhejiang University, China, and University of Cergy-Pontoise, France. From 2011, he became a Full Professor at the Department of Energy Technology, Aalborg University, Denmark, where he is the responsible of the Microgrids research program. His research interests is oriented to different Microgrids aspects, including power electronics, distributed energy storage systems, hierarchical and cooperative control, energy management systems and optimization of microgrids and islanded minigrids.

Prof. Guerrero is an Associate Editor for the IEEE Transactions on Power Electronics, IEEE Transactions on Industrial Electronics, and IEEE Industrial Electronics Magazine. He has been Guest Editor of the IEEE Transactions on Power Electronics Special Issues: Power Electrics for Wind Energy Conversion and Power Electronics for Microgrids; and the IEEE Transactions on Industrial Electronics Special Sections: Uninterruptible Power Supplies (UPS) systems, Renewable Energy Systems, Distributed Generation and Microgrids, and Industrial Applications and Implementation Issues of the Kalman Filter. He currently chairs the Renewable Energy Systems Technical Committee of IEEE IES.



Mukul Chandorkar (M'84) is a professor in the Department of Electrical Engineering at the Indian Institute of Technology, Bombay, India. He received the B. Tech. degree from the Indian Institute of Technology - Bombay, the M. Tech. degree from the Indian Institute of Technology - Madras, and the Ph.D. Degree from the University of Wisconsin-Madison, in 1984, 1987 and 1995 respectively, all in electrical engineering. He has several years of experience in the power electronics industry in India, Europe and the USA. His technical interests include microgrid decentralized operation, and he has authored several papers on the subject. His interests also include power quality compensation, power system wide-area measurements, real-time simulation and load emulation.



Tzung-Lin Lee (S'04–M'08) received the B.S. degree in electrical engineering from Chung Yuan Christian University, Taoyuan, TAIWAN, in 1993, the M.S. degree in electrical engineering from National Chung Cheng University, Chiayi, TAIWAN, in 1995, and the Ph.D. degree in electrical engineering from National Tsing Hua University, Hsinchu, TAIWAN, in 2007. From 1997 to 2001, he worked at the Microwave Department in Electronics Research & Service Organization (ERSO), Industrial Technology Research Institute (ITRI), Hsinchu, TAIWAN. He began his teaching career in Chang Gung University, Taoyuan, TAIWAN, in Sep. 2007. Since Aug. 2008, he joined the department of electrical engineering, National Sun Yat-sen University, Kaohsiung, TAIWAN, where he is currently an Assistant Professor. His research interests are in utility applications of power electronics, such as active power filters and Microgrids.



Poh Chiang Loh (S'01–M'04–SM'12) received his B.Eng (Hons) and M.Eng from the National University of Singapore in 1998 and 2000 respectively, and his Ph.D from Monash University, Australia, in 2002, all in electrical engineering. During the summer of 2001, he was a visiting scholar with the Wisconsin Electric Machine and Power Electronics Consortium, University of Wisconsin-Madison, USA, where he worked on the synchronized implementation of cascaded multilevel inverters, and reduced common mode control strategies for multilevel inverters. From 2002 to 2003, he was a project engineer with the Defence Science and Technology Agency, Singapore, managing defence infrastructure projects and exploring technology for defence applications. From 2003 to 2009, he was an assistant professor with the Nanyang Technological University, Singapore, and since 2009, he is an associate professor at the same

university. In 2005, he has been a visiting staff first at the University of Hong Kong, and then at Aalborg University, Denmark. In 2007 and 2009, he again returned to Aalborg University first as a visiting staff working on matrix converters and the control of grid-interfaced inverters, and then as a guest member of the Vestas Power Program.

In total, Dr. Loh has received two third paper prizes from the IEEE-IAS IPCC committee in 2003 and 2006, and he is now serving as an associate editor of the IEEE Transactions on Power Electronics.