



AALBORG UNIVERSITY
DENMARK

Aalborg Universitet

Distributed Secondary Control for Islanded MicroGrids - A Novel Approach

Shafiee, Qobad; Guerrero, Josep M.; Vasquez, Juan Carlos

Published in:
I E E E Transactions on Power Electronics

DOI (link to publication from Publisher):
[10.1109/TPEL.2013.2259506](https://doi.org/10.1109/TPEL.2013.2259506)

Publication date:
2014

Document Version
Early version, also known as pre-print

[Link to publication from Aalborg University](#)

Citation for published version (APA):
Shafiee, Q., Guerrero, J. M., & Vasquez, J. C. (2014). Distributed Secondary Control for Islanded MicroGrids - A Novel Approach. *I E E E Transactions on Power Electronics*, 29(2), 1018-1031.
<https://doi.org/10.1109/TPEL.2013.2259506>

General rights

Copyright and moral rights for the publications made accessible in the public portal are retained by the authors and/or other copyright owners and it is a condition of accessing publications that users recognise and abide by the legal requirements associated with these rights.

- Users may download and print one copy of any publication from the public portal for the purpose of private study or research.
- You may not further distribute the material or use it for any profit-making activity or commercial gain
- You may freely distribute the URL identifying the publication in the public portal -

Take down policy

If you believe that this document breaches copyright please contact us at vbn@aub.aau.dk providing details, and we will remove access to the work immediately and investigate your claim.

Distributed Secondary Control for Islanded MicroGrids - A Novel Approach

Qobad Shafiee, *Student Member, IEEE*, Josep M. Guerrero, *Senior Member, IEEE*, and Juan C. Vasquez, *Member, IEEE*

Abstract— This paper presents a novel approach to conceive the secondary control in droop-controlled MicroGrids. The conventional approach is based on restoring the frequency and amplitude deviations produced by the local droop controllers by using a MicroGrid Central Controller (MGCC). A distributed networked control system is used in order to implement a distributed secondary control (DSC) thus avoiding its implementation in MGCC. The proposed approach is not only able to restore frequency and voltage of the MicroGrid but also ensures reactive power sharing. The distributed secondary control does not rely on a central control, so that the failure of a single unit will not produce the fail down of the whole system. Experimental results are presented to show the feasibility of the DSC. The time latency and data drop-out limits of the communication systems are studied as well.

Keywords – Secondary control, Distributed Control, Networked Control Systems, Droop Control, Cooperative Control.

I. INTRODUCTION

MicroGrids (MGs) are local grids comprise different technologies such as power electronics converters, distributed generations (DGs), energy storage systems, and telecommunications which can operate connected to the traditional centralized grid (macrogrid) but also could operate autonomously in islanded mode.

Control structures are essential to proper control of MGs providing stability and efficient operation. The important roles that can be achieved using these control structures are frequency and voltage regulation, active and reactive power control between DG units and with the main grid, synchronization of MG with the main grid, energy management and economic optimization [1]-[13]. Recently, hierarchical control for MGs has been proposed in order to standardize their operation and functionalities [1]. In such a hierarchical approach, three main control levels have been defined. The primary control is the first level which is independent, dealing with the local control loops of the DG units. This can be performed by voltage and current loops, droop functions, and virtual impedances. Conventionally, the active power–

frequency droop control and the reactive power–voltage droop are adopted as the decentralized control strategies in the power electronic based MGs for the autonomous power sharing operations. Although the primary level does not require for communications, in order to achieve global controllability of the MG, secondary control is often used.

The conventional secondary control approach relays on using a MicroGrid Central Controller (MGCC), which includes slow controls loops and low bandwidth communication systems in order to measure some parameters in certain points of the MG, and to send back the control output information to each DG unit [1], [2]. On the other hand, this MGCC also can include tertiary control, which is more related to economic optimization, based on energy prices and electricity market [1]. Tertiary control exchanges information with the distribution system operator (DSO) in order to make feasible and to optimize the MG operation within the utility grid.

Secondary control is conceived to compensate frequency and voltage deviations produced inside the MG by the virtual inertias and output virtual impedances of primary control. This concept was used in large utility power systems for decades in order to control the frequency of a large area electrical network [14], [15] and it has been applied to MGs to restore frequency and voltage deviations [1], [2], [9]-[13]. Furthermore, global objectives regarding voltage control and power quality of the MG, such as voltage unbalance and harmonic compensation have been proposed recently in additional secondary control loops [16], [17]. In all of these literatures, a central secondary control (CSC) has been used in order to manage the MG.

On the other hand, the reactive power sharing of the Q–V droop control is hard to achieve, since the voltage is not constant along the MG power line, as opposed to the frequency [18]. Consequently, reactive power sharing can be achieved by implementing an external loop in the secondary level [19].

Significant efforts have been done in order to improve the primary control method for power sharing in the recent years. In [20], a power controller was proposed, which contains a virtual inductor loop for both active and reactive power decoupling, and an accurate reactive power sharing algorithm with an online impedance voltage drop effect estimation considering different location of the different local loads in a MG. This strategy, which is an improvement of the conventional droop method, operates in the primary control level therefore it does not need physical communications among DG units. Alternatively, a reactive power-sharing

Q. Shafiee, J. M. Guerrero, and J. C. Vasquez are with the Institute of Energy Technology, Aalborg University, Aalborg East DK-9220, Denmark (e-mails: qsh@et.aau.dk, joz@et.aau.dk, juq@et.aau.dk).

scheme has been presented in [21], which introduces an integral control of the load bus voltage, combined with a reference that is drooped against reactive power output. Further, active power sharing has improved by computing and setting the phase angle of the DGs instead of its frequency in conventional frequency droop control. In [22], a control strategy which increases the droop gain to improve the accuracy of reactive power sharing is proposed by making a feedback reactive power injection loop around the conventional droop loop of each DG, while maintaining the system stability. Additionally, secondary control loops implemented in the MGCC has proposed to share reactive power between DG units and also to restore the voltage deviations in [19]. In all those techniques, reactive power sharing cannot be achieved completely since voltage is a local variable, as a contrary of frequency.

Moreover, primary and tertiary controls are decentralized and centralized control levels respectively, since while one is taking care of the DG units, the other concerns about the MG global optimization. However, although secondary control systems conventionally have been implemented in the MGCC, in this paper we propose to implement it in a distributed way along the local control with communication systems. In this sense, a local secondary control is determined for each DG to generate set-points of the droop control to restore of the deviations produced by the primary control.

This kind of distributed control strategies, which are also named networked control systems (NCS), have been reported recently in some literatures [9], [23]-[24]. In [9], technical aspects of providing frequency control reserves (FCRs) and the potential economic profitability of participating in FCR markets for both decentralized and centralized coordination approach based on a setup of multiple MGs are investigated. In [23], a pseudo-decentralized control strategy has been presented for distributed generation networks which operate in distributed manner using a Global Supervisory Controller (GSC) and local controllers with some intelligence. In the other hand, a master-slave control by using networked control strategy for the parallel operation of inverters has been introduced in [24]. The method is employed to achieve the superior load-sharing accuracy compared to conventional droop scheme with low-bandwidth communication. Further, the system robustness has been considered in the case of communication failure as well. Distributed control strategies have been used in all these literatures, however, the application of these control strategies to secondary control of MGs still has not been proposed.

In this paper, a distributed secondary control strategy is proposed for power electronics-based MGs, including frequency, voltage and reactive power sharing controllers. This way, every DG has its own local secondary control which can produce appropriate control signal for the primary control level by using the measurements of other DGs in each sample time. In order to investigate the impact of communication on this new control strategy, the communication latency is considered when sending/receiving information to/from other DG units and the results are compared with the conventional MGCC.

The paper is organized as follows. In section II, the structure

of the primary control in MGs is described. Then, details of centralized secondary control for MGs are discussed in Section III. Section IV is dedicated to the proposed secondary control strategy, which includes frequency control, voltage control and reactive power sharing. Experimental results and discussion are presented in Section V. Furthermore, the proposed secondary control is applied on a two paralleled 2.2kW-inverter system as a case study. Finally, the paper is concluded in Section VI.

II. PRIMARY CONTROL FOR MICROGRIDS

Power electronics based MG consists of a number of elements that can operate in parallel either in islanded mode or connected to the main grid. Fig. 1 shows a general structure of MG, which composes n DG units. The MG is connected to the utility system through a static transfer switch (STS) at the point of common coupling (PCC). As depicted in Fig.1, each DG system comprises a renewable energy source (RES), an energy storage system (ESS), and a power electronic interface, which normally consist of a dc-ac inverter. Each DG can be connected to a predefined load or to the AC common bus directly in order to supply power.

The dc/ac inverters are classified as voltage source inverters (VSIs) and current source inverters (CSIs) which the former is commonly used to inject current in grid connected modes and the latter to keep the frequency and voltage stable in autonomous operation. Both can operate in parallel in a MG. However, VSIs are convenient since they can enhance power quality and ride-through capability for DGs in a MG [1], [25].

The primary control of VSIs based MG includes voltage and current control loops, virtual impedance loop and droop control strategy as shown in Fig. 3. Linear and nonlinear control strategies are designed and performed in order to regulate the output voltage and to control the current while maintaining the system stable. Normally, inner control loops include proportional-resonant (PR) controller when they use stationary framework ($\alpha\beta$), and proportional-integral (PI) controller when they use the dq framework. The reference of the voltage control loop will be generated, together with the droop controller and a virtual impedance loop.

Droop control is responsible for adjusting the frequency and the amplitude of the voltage reference according to the active and reactive powers (P and Q), by using the well-known P/Q droop method [1], [25]- [29]. Furthermore, a virtual impedance loop is also added to the voltage reference in order to fix the output impedance of the VSI which will determine the P/Q power angle/amplitude relationships based on the droop method control law. In contrast with physical impedance, this virtual output impedance has no power losses, and it is possible to implement resistance without efficiency losses [13]. More details about the primary control can be found in [1], [13], being out of scope of this paper.

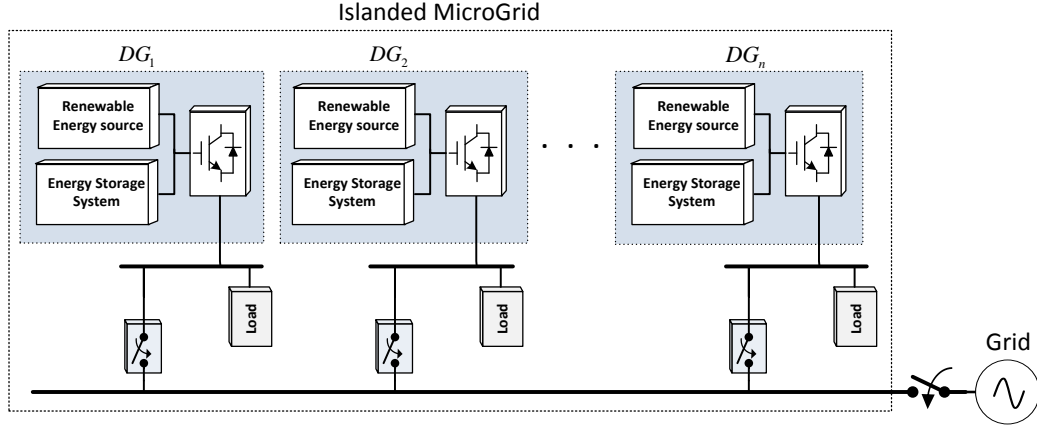

Fig. 1. General structure of MG.

III. CENTRALIZED SECONDARY CONTROL FOR MICROGRIDS

Since the primary control is local and does not have intercommunications with other DG units, in order to achieve global controllability of the MicroGrid, secondary control is often used. Conventional centralized secondary control loop is implemented in MGCC [2]. Fig. 2 shows MG secondary control architecture consists of a number of DG units locally controlled by a primary control and a secondary control, which measures from a remote sensing block a number of parameters to be sent back to the controller by means of a low bandwidth communication system. Hence, those variables are compared with the references in order to be compensated by the secondary control, which will send the output signal through the communications channel to each DG unit primary control. The advantage of this architecture is that the communication system is not too busy, since only unidirectional messages are sent in only one direction (from the remote sensing platform to the MGCC and from the MGCC to each DG unit primary control). The drawback is that the MGCC is not highly reliable since a failure of this controller is enough to stop the secondary control action.

A. Frequency control

Traditionally, secondary controllers for large power systems are based on frequency restoration, since the frequency of the generator-dominated grids is highly dependent on the active power. This fact is an advantage since frequency is a control variable that provides information related to the consumption/generation balance of the grid. This central controller, named Load Frequency Control (LFC) in Europe or Automatic Generation Control (AGC) in USA, is based on a slow PI control with a dead band that restores the frequency of the grid when the error is higher than a certain value, e.g. +/-50 mHz in the north of Europe.

Similar concept has been implemented in MGCC in order to restore the frequency of P-f droop controlled MG [4]. The frequency restoration compensator can be derived as follows.

$$\delta f = k_{pf} (f_{MG}^* - f_{MG}) + k_{if} \int (f_{MG}^* - f_{MG}) dt \quad (1)$$

being k_{pf} and k_{if} the control parameters of the secondary control PI compensator. The frequency levels in the MG (f_{MG}) are measured and compared to the references (f_{MG}^*) and the errors processed through the compensators (δf) are sent to all the DG units in order to restore the frequency of MG.

B. Voltage control

The voltage also can be controlled by using similar procedure as the frequency secondary control [1]. When the voltage in the MG is out from a certain range of nominal rms values, a slow PI control that compensates the voltage amplitude in the MG, pass the error through a dead band, and send the voltage information by using low bandwidth communications to each DG unit. Thus, it can be implemented together with the frequency restoration control loop at the MGCC. The voltage restoration control loop can be expressed as follows:

$$\delta E = k_{pE} (E_{MG}^* - E_{MG}) + k_{iE} \int (E_{MG}^* - E_{MG}) dt \quad (2)$$

being k_{pE} and k_{iE} the PI controller parameters of the voltage secondary control. The control signal (δE) is sent to the primary control level of each DG in order to remove the steady state errors produced by droop control.

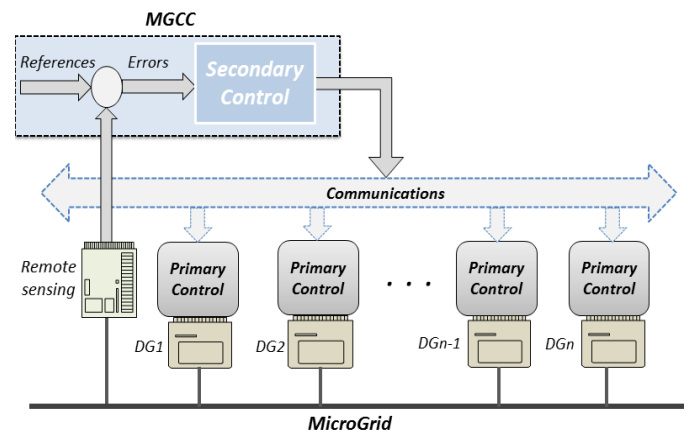

Fig. 2. Centralized secondary control.

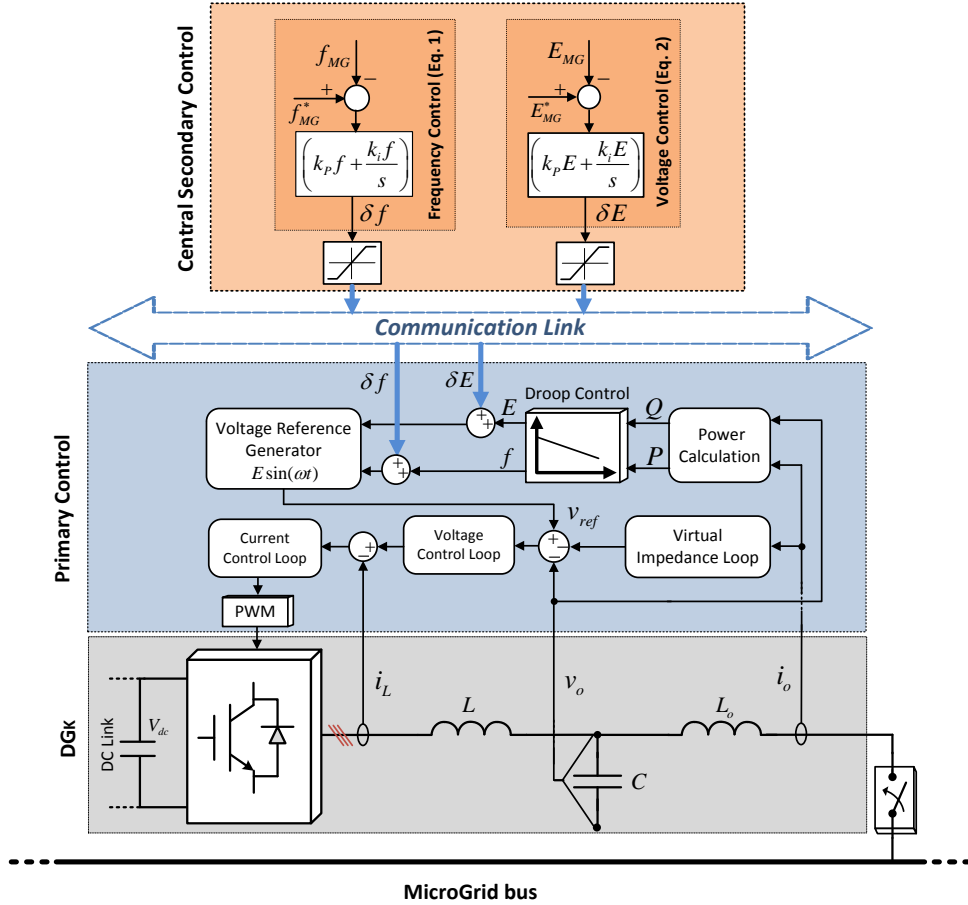

Fig. 3. Scheme of the central secondary control for a DG unit in a MG.

This approach can be also extended to more resistive MGs by using P - V droops in the primary control, and restoring the voltage of the MG by sending the voltage correction information to adjust the voltage reference. Thus, voltage and frequency restoration controllers can be used in any R/X condition by means of the park transformation in the primary control. Consequently, the secondary control is transparent to the R/X nature of the power lines, as opposed to the primary control.

Fig. 3 depicts details of centralized secondary control structure for an individual DG unit (DG_k) in an islanded MG based on equations (1) and (2). As seen, The frequency and voltage levels in the MG are measured and compared to their references, then errors processed through the compensators are sent to primary control level of all DG units in order to restore the deviations in the MG.

IV. PROPOSED DISTRIBUTED SECONDARY CONTROL

The problem of using the MGCC for implementing secondary control is that a failure can result in a bad function of the whole system. In order to avoid a single centralized controller, a distributed control system approach is proposed in this paper. However, even with this new control strategy there is need of MGCC for coordination of units during black start

process and among other management functionalities of MG. The initial idea is to implement primary and secondary controllers together as a local controller. Fig. 4 shows the diagram of a fully distributed control system. Primary and secondary controls are implemented in each DG unit. The secondary control is placed between the communication system and the primary control. Frequency control, voltage control, and reactive power sharing will also be reviewed by using this control approach. However, this control strategy can be used to share active power in high R/X MGs as well.

In this case, secondary control in each DG collects all the measurements (frequency, voltage amplitude, and reactive power) of other DG units by using the communication system, average them and produce appropriate control signal to send to the primary level removing the steady state errors.

Fig. 5 illustrates details of the proposed distributed secondary control for an individual DG (DG_k) in a MG.

A. Frequency control

Taking the idea from large electrical power systems, in order to compensate the frequency deviation produced by the local P - ω droop controllers, secondary frequency controllers have been proposed [26]. However, the approach needs communications in order to avoid instability in the MG system caused probably by different stories of each local inverter.

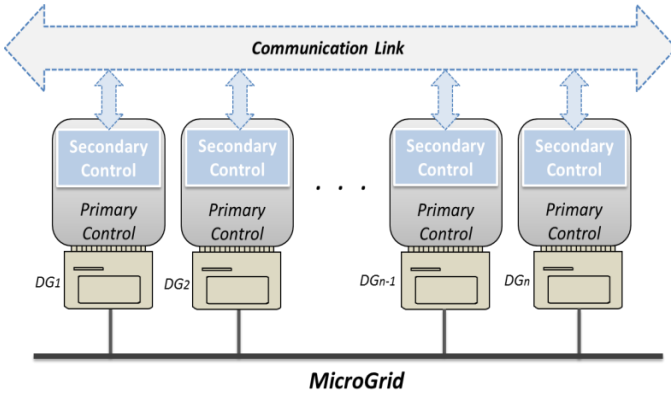

Fig. 4. Networked controlled MG system.

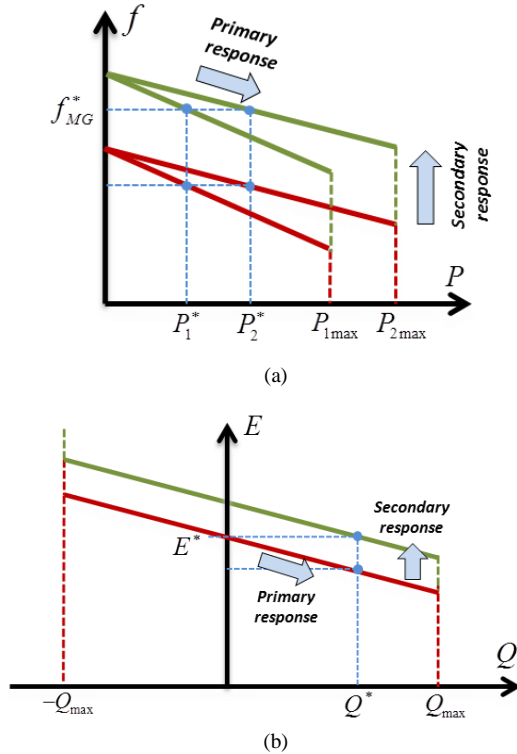

Fig. 6. Secondary control response vs primary control response. (a) frequency restoration (b) Voltage amplitude restoration.

In the proposed secondary control strategy, each DG measures the frequency level in every sample time, sends it to others, averages the frequency measured by other DGs, and then restores the frequency internally as

$$\delta f_{DG_k} = k_{pf} (f_{MG}^* - \bar{f}_{DG_k}) + k_{if} \int (f_{MG}^* - \bar{f}_{DG_k}) dt \quad (3)$$

$$\bar{f}_{DG_k} = \frac{\sum_{i=1}^N f_{DG_i}}{N}$$

being k_{pf} and k_{if} the PI controller parameters, f_{MG}^* is the MG frequency reference, \bar{f}_{DG_k} is the frequency average for all DG units and δf_{DG_k} is the control signal produced by the secondary control of DG_k in every sample time. Here, $i = 1, 2, \dots, N$,

$k = 1, 2, \dots, n$, N is the number of packages (frequency measurements) arrived through communication system and n is number of DG units.

Fig. 6 shows how secondary control removes frequency and voltage deviation caused by primary level in the MG units. In the Fig. 6 (a), behavior of primary and secondary control for two DGs with different droop coefficient has been depicted.

This figure demonstrates that secondary control just shifts up the primary response so that frequency reaches to the nominal value, even for the DGs with different power rates. It is worth noting that power change requirement for the proposed DSC using the average method depends on the power rates of the MG units.

In order to analyze the system and to adjust the parameters of DSC for frequency restoration, a small signal model has been developed for low R/X MGs [1], [30], according to (3) and P- ω droop control law.

$$\omega_{DG_k} = \omega_{DG_k}^* + G_p(s)(P_{DG_k}^* - P_{DG_k}) \quad (4)$$

The active power of DG_k in a low R/X islanded MG can be presented as follows [30]

$$P_{DG_k} = \frac{E_{DG_k} E_{com} \cos(\varphi_{DG_k} - \varphi_{com})}{X_k} \quad (5)$$

where E_{com} is voltage at the point of common coupling (PCC), φ_{com} is the phase between DG_k and PCC, and X_k is inductance between DG_k and PCC, respectively. The small signal dynamic of P- ω droop control can be obtained by linearizing equations (4) and (5) at an operating point P_{k0} and φ_{k0} :

$$\Delta \omega_{DG_k} = \Delta \omega_{DG_k}^* + G_p(s)(\Delta P_{DG_k}^* - \Delta P_{DG_k}) \quad (6)$$

$$\Delta P_{DG_k}(s) = G \cdot \Delta \varphi_{DG_k}(s) \quad (7)$$

$$\text{where } G = \frac{E_{k0} E_{com} \cos(\varphi_{k0} - \varphi_{com})}{X_k}$$

The block diagram of small signal model for frequency control is shown in Fig. 7, which includes droop control model and distributed secondary control model. For droop control model a low pass filter with cutting frequency of 0.2 Hz has been considered for power calculation ($G_{LPF}(s)$) [30]. The secondary control has been modeled by means of a simplified phase locked loop (PLL) first-order transfer function ($G_{PLL}(s)$) used to extract the frequency of the DG [13], a proportional gain (k_a) to make frequency average with frequency measurements of other DGs ($\Delta \omega_{avg}$), and a PI controller ($G_{fsec}(s)$).

The characteristic equation can be obtained from Fig.7 as follows

$$\Delta_f = 1 + G_{LPF}(s) \cdot G_p(s) \cdot \frac{1}{s} \cdot G + G_{PLL}(s) \cdot k_a \cdot G_{fsec}(s) \quad (8)$$

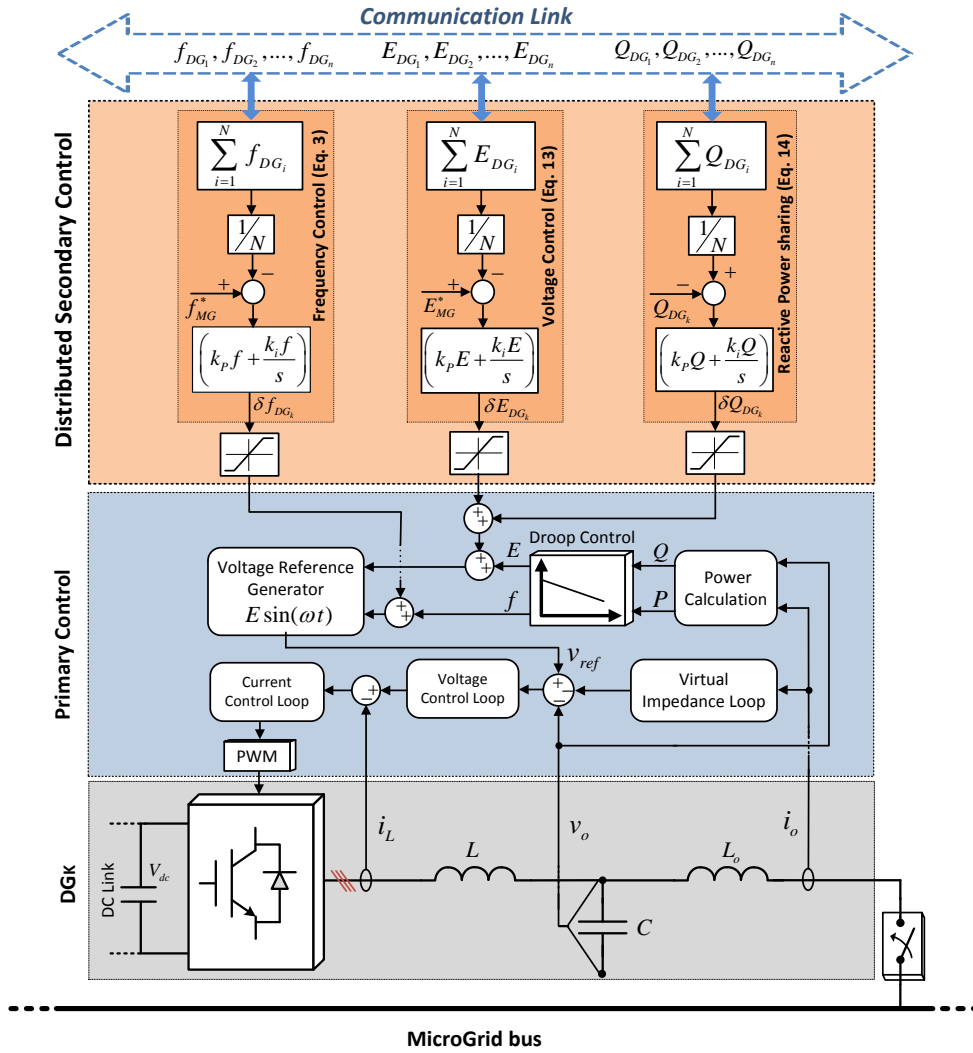

Fig. 5. Scheme of the proposed distributed secondary control for a DG unit in a MG.

where $k_a = \frac{1}{N}$ is a parameter to obtain the average of frequency. Other transfer functions can be express as

$$G_{LPF}(s) = \frac{1}{1 + \tau_p s} \quad (9)$$

$$G_{PLL}(s) = \frac{1}{1 + \tau s} \quad (10)$$

$$G_p(s) = \frac{k_{pP}s + k_{iP}}{s} \quad (11)$$

$$G_{f_{sec}}(s) = \frac{k_{pf}s + k_{if}}{s} \quad (12)$$

being k_{iP} the droop coefficients, while k_{pP} can be considered as a virtual inertia of the system. By analyzing eigenvalues obtained from (8), we can adjust properly the control parameters of droop and secondary control [25].

B. Voltage control

Similar approach can be used as in the distributed frequency control one, in which each inverter will measure the voltage

error, and tries to compensate the voltage deviation caused by the $Q-E$ droop. The advantage of this method in front of the conventional one is that the remote sensing used by the secondary control is not necessary, so that just each DG terminal voltage, which can be substantially different one from the other, is required. In this case, the voltage restoration is obtained as follows:

$$\delta E_{DG_k} = k_{pE} (E_{MG}^* - \bar{E}_{DG_k}) + k_{iE} \int (E_{MG}^* - \bar{E}_{DG_k}) dt \quad (13)$$

$$\bar{E}_{DG_k} = \frac{\sum_{i=1}^N E_{DG_i}}{N}$$

where δE_{DG_k} is the restoration voltage of DG_k is produced by using the PI control of the error between voltage reference of MG (E_{MG}^*) and voltage average of DG units (\bar{E}_{DG_k}) in every sample time.

According to the proposed average method, secondary control is able to remove voltage deviations caused by primary control level in every DG unit as shown in Fig. 6 (b).

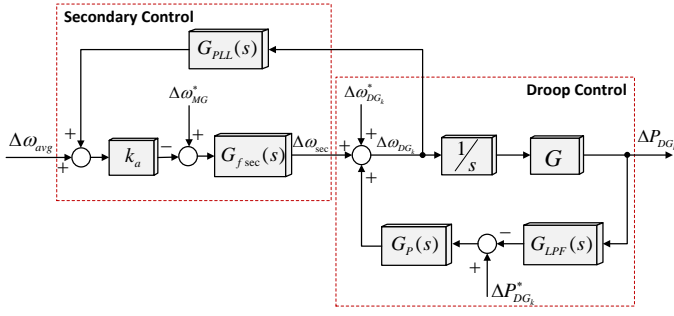

Fig. 7. Small signal model of distributed frequency control for a DG unit in a low R/X islanded MGs.

C. Line impedance independent power equalization

It is well-known that in a low R/X MicroGrid the reactive power is difficult to be accurately shared, and the same effect occurs when trying to share active power in high R/X MicroGrids. The reason is that as opposed to the frequency, the voltage is not common in the whole MG as well as the impedance between the DG units and common point is not the same. Therefore, by using the voltage as a variable is hard to control Q flow (or P in case of resistive line MG). As a result, reactive power is not precisely controlled by using the $E-Q$ droop control. Fig. 7 demonstrates this concept. In Fig. 8(a) a simple example has been displayed which consist of two units. As seen voltage and phase of DG units as well as impedance between DGs can be different, so that Q cannot be shared between DG units. Fig. 8(b) depicts that by using E-Q droop, reactive power is not perfectly shared because voltage is not common in DGs.

As aforementioned, several methods have been reported to improve the reactive power sharing by using only primary control loop. In all those techniques reactive power sharing cannot be precisely achieved since the voltage is a local variable. Moreover, Tuladhar *et Al.* have proposed the use of a small ripple between converters in order to compensate the errors due to the different voltage drops along the electrical network of a MG [18]. However this method is difficult to be applied with MGs that contains more than two DG units.

Alternatively, a possible solution is to implement a secondary control for power sharing locally, so that each DG unit sends the measured Q (or P in high X/R MicroGrids) to the other DG units in order to be averaged. This way, as the information is common, all of them will have the same reference. Therefore, the reactive power sharing by the secondary control can be expressed as

$$\delta Q_{DG_k} = k_{pQ} (\bar{Q}_{DG_k} - Q_{DG_k}) + k_{iQ} \int (\bar{Q}_{DG_k} - Q_{DG_k}) dt \quad (14)$$

$$\bar{Q}_{DG_k} = \frac{\sum_{i=1}^N Q_{DG_i}}{N}$$

being k_{pQ} as the proportional term, k_{iQ} is the integral term, Q_{DG_k} is reactive power of DG_k, \bar{Q}_{DG_k} is average of reactive power for

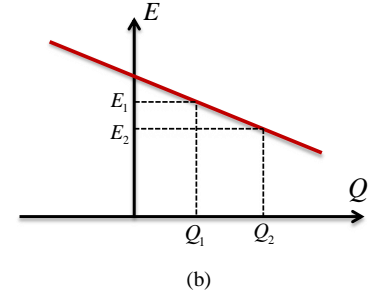
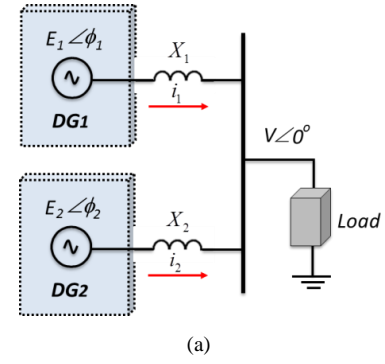

Fig. 8. Q-E droop control problem in reactive power sharing.

all DG units which act as a reactive power reference, and δQ_{DG_k} is the control signal produced by the secondary control in every sample time, to share the reactive power between the DG units. This way, reactive power sharing can be obtained independently from voltage sensing mismatches or line impedances in the MG.

It is noteworthy that, the outputs of secondary control must be limited, as shown in Fig. 5, in order to not exceed the maximum allowed frequency and amplitude deviations as well as maximum reactive power that each unit can inject or absorb.

Similar small signal model as in the frequency control one can be obtained for voltage control and reactive power sharing by using equations (13), (14) and Q-E droop control law.

$$E_{DG_k} = E_{DG_k}^* + G_Q(s)(Q_{DG_k}^* - Q_{DG_k}) \quad (15)$$

The reactive power of DG_k in a low R/X islanded MG can be presented as follows [30]

$$Q_{DG_k} = \frac{E_{DG_k}^2 - E_{DG_k} E_{com} \cos(\varphi_{DG_k} - \varphi_{com})}{X_k} \quad (16)$$

By linearizing equations (15) and (16) at an operating point Q_{k0} , E_{k0} and φ_{k0} the small signal dynamic of Q-E droop control can be obtained.

$$\Delta E_{DG_k} = \Delta E_{DG_k}^* + G_Q(s)(\Delta Q_{DG_k}^* - \Delta Q_{DG_k}) \quad (17)$$

$$\Delta Q_{DG_k}(s) = H \cdot \Delta E_{DG_k}(s) + F \cdot \Delta E_{com}(s) \quad (18)$$

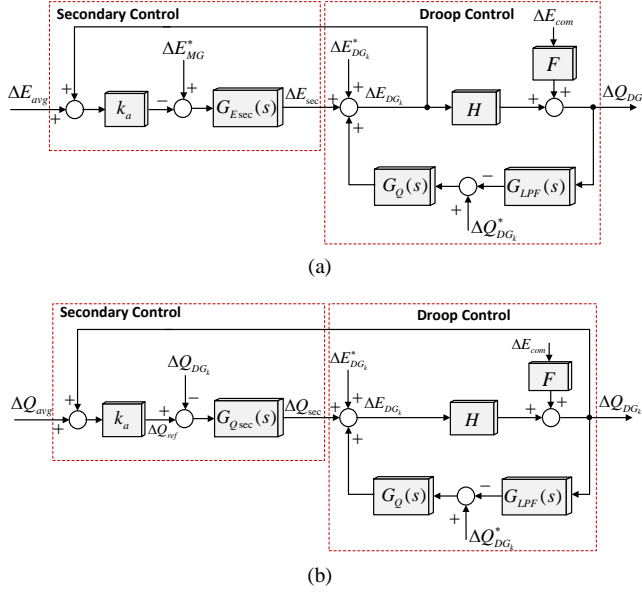

Fig. 9. Small signal model of distributed control for a DG unit in a low R/X islanded MicroGrids a) voltage control b) reactive power sharing.

$$\text{where } F = -\frac{E_{DG_k} \cos(\varphi_{k0} - \varphi_{com})}{X_k},$$

$$H = -\frac{2E_{k0} - E_{com} \cos(\varphi_{k0} - \varphi_{com})}{X_k}$$

Taking in to account a low pass filter to reactive power calculation, block diagram of Q-E droop control for an individual DG unit in a low R/X MicroGrid is shown in Fig. 9. The small signal model of the secondary control for voltage restoration and reactive power sharing has been derived by using equations (13) and (14), and has been depicted in Figs. 9(a) and 9(b) respectively. The characteristic equations for voltage control and Q sharing is presented as (19) and (20)

$$\Delta_E = 1 + (G_{LPF}(s) \cdot G_Q(s) \cdot H) + (k_a \cdot G_{Esec}(s)) \quad (19)$$

$$\Delta_Q = 1 + (G_{LPF}(s) \cdot G_Q(s) \cdot H) + (k_a \cdot H \cdot G_{Qsec}(s)) \quad (20)$$

where transfer functions can be express as

$$G_Q(s) = k_{pQ} \quad (21)$$

$$G_{Esec}(s) = \frac{k_{pE}s + k_{iE}}{s} \quad (22)$$

$$G_{Qsec}(s) = \frac{k_{pQ}s + k_{iQ}}{s} \quad (23)$$

being k_{pQ} the droop coefficient, $G_{Esec}(s)$ and $G_{Qsec}(s)$ are transfer function of PI controller for voltage restoration and Q sharing. These models allow us to set the control parameters of secondary control properly.

V. EXPERIMENTAL RESULTS AND DISCUSSION

An experimental MG setup as shown in Fig. 10 was used to test the performance of the proposed approach, consisted on two DG inverters forming as an islanded MG. Fig. 11 shows an experimental setup with the two Danfoss 2.2 kW inverters, the dSPACE1103 control board, LCL filters, and measurement LEM sensors. A diode rectifier is used as nonlinear load, loaded by a capacitor, and a 200 ohms linear load. The switching frequency was 10 kHz. The electrical setup and control system parameters are listed in Table I. All the parameters are the same for both DG units. All parameters have been adjusted based on the developed model. The secondary control parameters have been selected so that its response at least six times is slower than primary control [25].

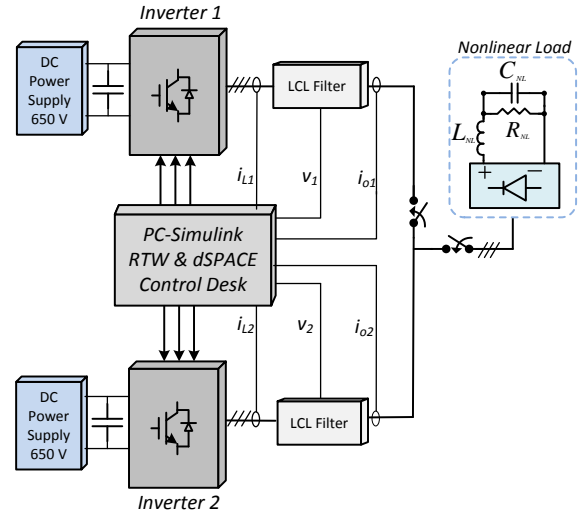

Fig. 10. Schematic of Experimental setup.

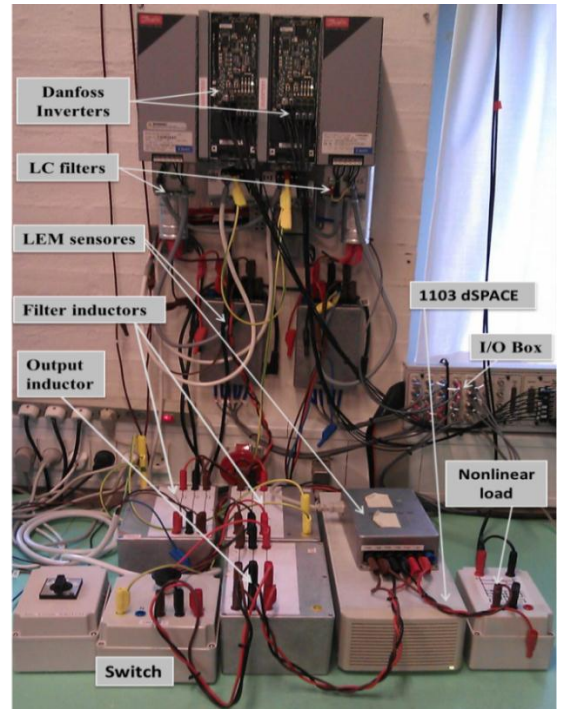

Fig. 11. Experimental setup.

TABLE I
ELECTRICAL SETUP AND CONTROL SYSTEM PARAMETERS

Type	Parameters		Value
	Symbol	Quantity	
Electrical setup	V_{dc}	DC Voltage	650 V
	V_{MG}	MG Voltage	311 V
	F	MG Frequency	50 Hz
	C	Filter Capacitance	25 μ F
	L	Filter Inductance	1.8 mH
	L_o	Output Impedance	1.8 mH
	R_L	Resistance Load	200 Ω /400 Ω
	L_{NL}	Nonlinear load inductance	0.084 mH
	R_{NL}	Nonlinear load resistance	50 Ω
	C_{NL}	Nonlinear load capacitance	235 μ F
Inner Loops	k_{pI}	Current proportional term	0.35
	k_{iI}	Current integral term	200
	k_{pV}	Voltage proportional term	0.35
	k_{iV}	Voltage integral term	400
Droop Control	k_{pP}	Active power droop coefficient	0.00001 Ws/rd
	k_{iP}	Active power droop integral term	0.0008 Ws/rd
	k_{pQ}	Reactive power droop coefficient	0.16 VAr/V
	R_v	Virtual Resistance	1 Ω
	L_v	Virtual Inductance	4 mH
Secondary Control	k_{pF}	Frequency proportional term	0.001
	k_{iF}	Frequency Integral term	4 s^{-1}
	k_{pE}	Amplitude proportional term	0.001
	k_{iE}	Amplitude Integral term	0.6 s^{-1}
	K_{pQ}	Reactive power proportional term	0.0001 VAr/V
	k_{iQ}	Reactive power integral term	0.3 VAr/Vs
	τ	PLL time constant	50 ms

Four different sections have been considered to present the experimental results. In the first section, procedure of black start for the MG setup is illustrated. Then, performance of the new secondary control strategy in restoring frequency and voltage variations as well as reactive power sharing for different scenarios is depicted in the subsection B. In the subsections C and D, the effects of communication latency delay and data drop-out on the proposed secondary control is investigated and the results are compared with the conventional secondary control. In this comparison, all the electrical and control parameters are the same for both distributed and central controllers as listed in Table I.

A. Black Start Process for the Proposed DSC

If a blackout occurs in a MG, a sequence of actions and conditions must be checked during the restoration procedure which called black start process. Conventionally, the MG black start will be performed centrally by the MGCC based on the information stored in a database about the last MG load scenario. This central controller detects the occurrence of a blackout and decides when to trigger the MG black start procedure. Local controllers and the communication infrastructure are important for the success of the restoration scheme in the MG. The main steps to be considered include building the islanded MG, connecting distributed generations (DGs) which feed their own protected loads, controlling voltage and frequency, synchronizing DG units inside islanded MG, connecting controllable loads and MG synchronization with the LV network [31].

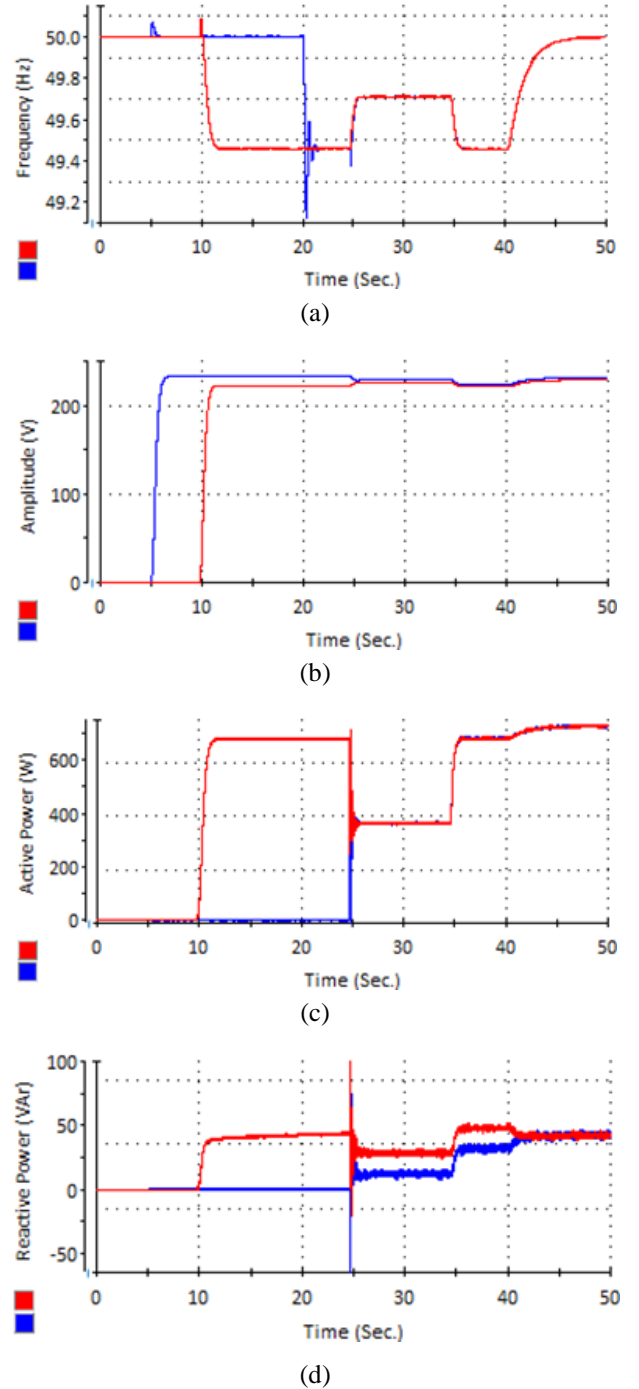

Fig. 12. Black start process for the islanded MG setup based on the proposed DSC a) frequency b) voltage amplitude c) active power d) reactive power.

Fig. 12 shows the black start process for the islanded MG setup. As can be observed in this figure, DG units 1 and 2 start to act at $t=5s$ and $t=10s$ respectively while primary control (inner loops and droop control loop) is running. DG₁ is in no load operation at the time, while DG₂ is connected to 400 Ω load feeding around 700 W and 50 VAr to the line impedance. A large amount of frequency deviation is seen as a result of load connection to the DG₂. After activating synchronization process ($t=20s$), DG units are connected at $t=25s$ and then they work as an islanded MG. As seen, active power is shared after

this point, however primary control is not able to share reactive power between DG units. Then, a load was connected to the built islanded MG at $t=35s$, which produce more frequency and voltage deviation. Finally, DSC is activated at $t=40s$, which remove deviations and shares reactive power between two DGs.

B. Frequency/Voltage Restoration and Q Sharing

The performance of DSC applied to a MG has been depicted in Fig. 13. Fig 13(a) and Fig 13(b) showing how the new secondary control strategy restores frequency and voltage deviation of the DGs. Frequency and voltage deviations are seen at $t=3s$ and $t=5s$ when loads suddenly are connected to the MG. At $t=10s$, the restoration process starts to act by activating the DSC for both DG units at the same time. It can be seen that frequency and voltage values are slowly and successfully regulated inside the islanded MG, removing the static deviations produced by the droop control. Frequent load changes has been considered at $t=20s$ (from 200Ω to 400Ω) and $t=27s$ (from 400Ω to 200Ω) respectively. As seen, DSC restores frequency and voltage amplitude properly after changing the load. In the last scenario impact of disconnection of one DG on the whole system has been investigated. At $t=35s$ DG₁ is disconnected from the MG setup, however DSC is still active for that DG as well. As seen in the results, DSC restores voltage and frequency successfully even after disconnection of a unit from the MG. Results show restoration process of frequency and amplitude for DG₁ as result of its own local secondary control effort.

Fig 13(c) shows active power changes in the DGs for each scenario. This figure shows that active power can be shared sufficiently between DGs even before activating the DSC by means of droop control. These results illustrates that the P-f droop control is sufficient to share the active power accurately since the frequency is a global variable in a MG. Notice that there is a small increase in active power to restore the frequency deviation when secondary control is activated.

In Fig. 13(d), reactive power sharing has been illustrated. This figure demonstrates the effectiveness of the proposed secondary control method when reactive power is shared. As seen, while there is a big difference between reactive power of DGs as a result of the droop control, the DSC is able to share properly the reactive power between the DGs. The proposed distributed secondary control is able to keep the reactive power shared between DG units when the load changes frequently as well. After disconnection of DG₁ from the MG system in the last scenario, DG₂ feeds the entire load by injecting double active power.

In order to evaluate the effectiveness of the proposed DSC for islanded MGs which have units with different power rates, another experiment was done when power rate of unit 2 was double of unit 1. Fig. 14 illustrates frequency response of the system to a frequent step load changes as well as corresponding active power of the units.

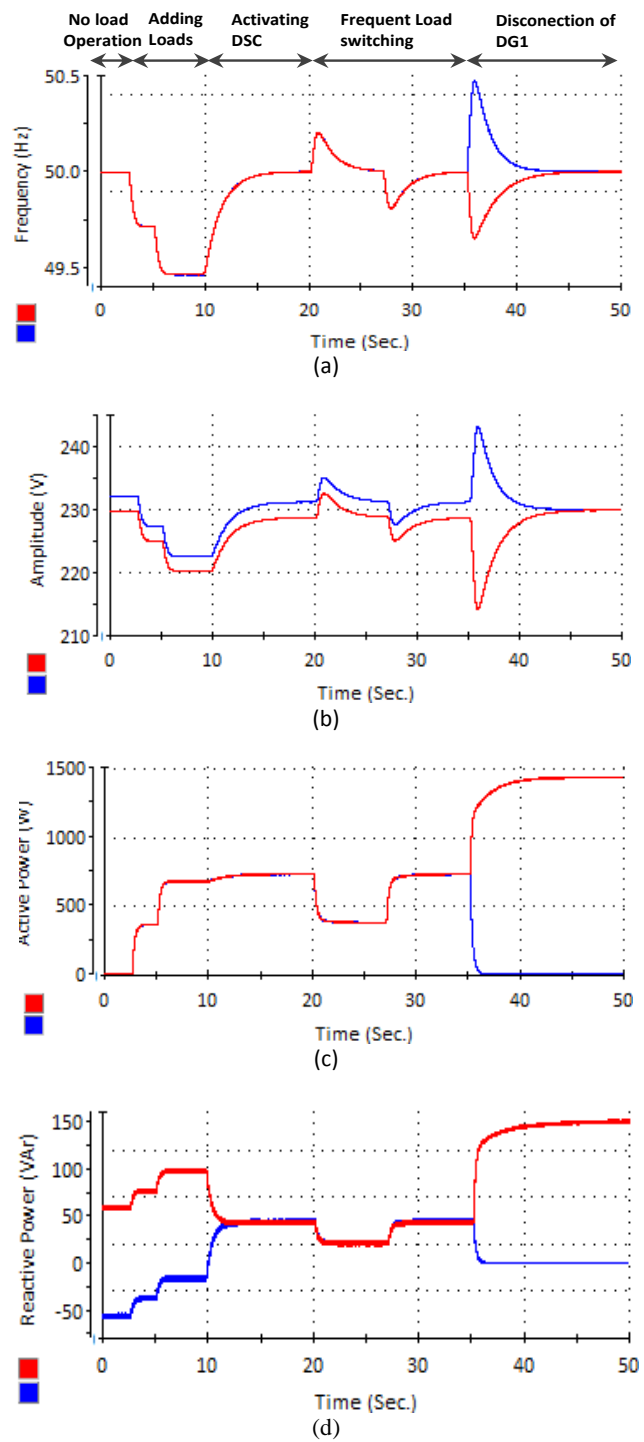

Fig. 13. Performance of DSC in a) frequency restoration b) voltage amplitude restoration c) active power sharing d) reactive power sharing. DG1 (blue), DG2 (red).

It can be seen that even with different power rate, the DSC with the proposed averaged method is still able to regulate the system frequency successfully. This figure verifies the concept of Fig. 6 that primary control determines the power rate of MG units, and secondary control is responsible for recovering the deviations of the units. It is worth to mention that restoration process requires different amount of power according to the power rate of the units.

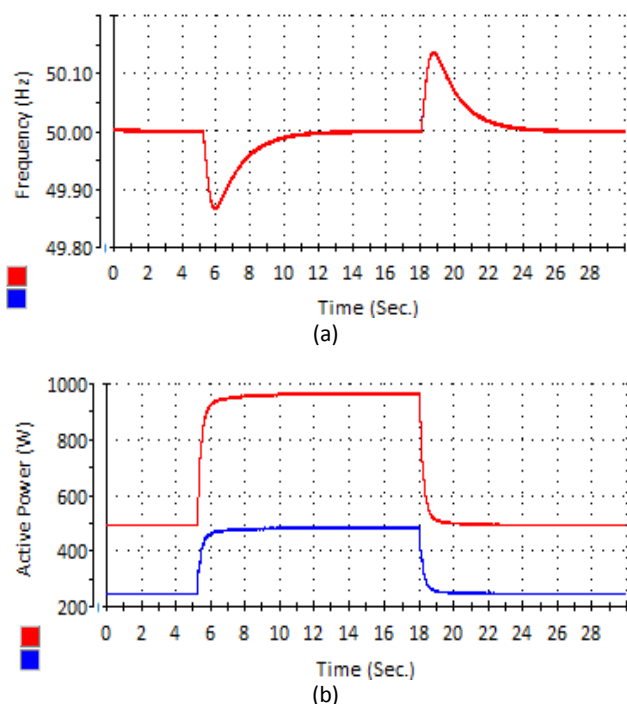

Fig. 14. Performance of the DSC for an islanded MG consists of two DGs with different power rates. a) Frequency b) Active power. DG1 (blue), DG2 (red).

C. Impact of Communication Latency

Communication has a predominant role in providing the infrastructure that enables data to be exchange among the different elements of the MG. This importance increases when DSC is used for the secondary level of the MGs.

In this section, the impact of communication latency on the proposed control approach is presented, and then compared with those in the conventional centralized approach. Performance of the distributed secondary control has been compared with the central one for three amounts of fixed communication latency, 200ms, 1sec. and 2sec. For sake of simplicity, only frequency and voltage responses are depicted. Table II illustrates the effects of the communication delay on the control strategies performance, when they remove frequency and voltage deviations.

As can be seen, both controllers have good performance for the time delay of 200ms. However, the central one is not able to restore the frequency and voltage well in the MG when communication delay is up to 1 second. For a communication delay of 2 second, as presented in Table II, the central controller cannot make the system stable, becoming unstable after a while. However, the proposed control strategy is able to be stable with a delay of 4 second.

D. Effect of Data Drop-Out

In the real communication system, there may exist data drop-out or packet losses which can affect the system output performance. The performance of proposed secondary control in the presence of data drop-out is illustrated in Table III, comparing to the central one. Results have been shown for

different amount of packet losses, 50% and 95%, considering 100 ms communication delay. It can be seen that both controllers has an acceptable performance in restoring frequency and voltage deviation for 50% of data drop-out. When data drop-out is up to 95%, the central controller is not able to control the system and system goes to instability after a while. However, the proposed distributed controller is still stable and restores deviations properly.

VI. CONCLUSION

This paper has introduced a distributed control strategy for droop controlled MGs. In this method, a decentralized secondary control encompasses every DG unit local controller and the communication system. Thus producing an appropriate control signal to be locally sent to the local primary controller. In this sense, the failure of a DG unit will fail down only that individual unit and other DGs can work independent. Thus, adding more DG units is easy, making the system expandable. However, still having a MGCC is mandatory to achieve some other purposes like coordination of the MG units in black start process or energy management.

The concept is evaluated based on the system performance in a laboratory case study with the goal of regulating voltage and frequency, and at the same time properly sharing reactive power between DG units. Furthermore, the impact of communication system delay as well as data drop-out over the MG has been compared between the proposed decentralized secondary control system and the conventional centralized one.

The results experimental showed that the proposed control strategy has a good performance in removing frequency and voltage steady state errors and can share reactive power between DG units perfectly. Even though the proposed secondary control needs more information interchange capability, however, it shown higher robustness in front large communication latency delays and data drop-out.

TABLE II
PERFORMANCE OF DISTRIBUTED SECONDARY CONTROL CONSIDERING COMMUNICATION LATENCY, WHEN COMPARED WITH THE CENTRAL SECONDARY CONTROL

Time Delay	Central Secondary Control		Distributed Secondary Control	
200ms	Frequency Restoration			
	Voltage Restoration			
1sec.	Frequency Restoration			
	Voltage Restoration			
2sec.	Frequency Restoration			
	Voltage Restoration			

TABLE III
PERFORMANCE OF DISTRIBUTED SECONDARY CONTROL CONSIDERING DATA DROP-OUT, WHEN COMPARED WITH THE CENTRAL SECONDARY CONTROL

Data Drop-out		Central Secondary Control	Distributed Secondary Control
50 %	Frequency Restoration		
	Voltage Restoration		
95 %	Frequency Restoration		
	Voltage Restoration		

REFERENCES

- [1] J. M. Guerrero, J. C. Vásquez, J. Matas, M. Castilla, L. G. D. Vicuña, and M. Castilla, "Hierarchical Control of Droop-Controlled AC and DC Microgrids—A General Approach Toward Standardization," *IEEE Trans. Ind. Electron.*, vol. 58, no. 1, pp. 158–172, Jan. 2011.
- [2] J. A. P. Lopes, C. L. Moreira, and A. G. Madureira, "Defining control strategies for microgrids islanded operation," *IEEE Trans. Power Syst.*, vol. 21, pp. 916–924, May 2006.
- [3] M. C. Chandorkar, D. M. Divan, and R. Adapa, "Control of parallel connected inverters in standalone AC supply systems," *IEEE Trans. Ind. Appl.*, vol. 29, pp. 136–143, Jan./Feb. 1993.
- [4] Y. A. R. I. Mohamed and A. A. Radwan, "Hierarchical control system for robust microgrid operation and seamless mode transfer in active distribution systems," *IEEE Trans. Smart Grid*, vol. 2, pp. 352–362, Jun. 2011.
- [5] K. Jaehong, J. M. Guerrero, P. Rodriguez, R. Teodorescu, N. Kwanghee, "Mode Adaptive Droop Control With Virtual Output Impedances for an Inverter-Based Flexible AC Microgrid," *IEEE Trans. Power Electron.*, vol. 26, no. 3, pp. 689–701, March 2011.
- [6] F. Katiraei, M. R. Iravani, and P. W. Lehn, "Microgrid autonomous operation during and subsequent to islanding process," *IEEE Trans. Power Del.*, vol. 20, pp. 248–257, Jan. 2005.
- [7] S. Anand, B. G. Fernandes, J. M. Guerrero, "Distributed Control to Ensure Proportional Load Sharing and Improve Voltage Regulation in Low-Voltage DC Microgrids," *IEEE Trans. Power Electron.*, vol. 28, no. 4, pp. 1900–1913, April 2013.
- [8] H. Nikkhajoei and R. H. Lasseter, "Distributed generation interface to the CERTS microgrid," *IEEE Trans. Power Del.*, vol. 24, pp. 1598–1608, Jul. 2009.
- [9] C. Yuen, A. Oudalov, and A. Timbus, "The provision of frequency control reserves from multiple microgrids," *IEEE Trans. Ind. Electron.*, vol. 58, pp. 173–183, Jan. 2011.
- [10] A. Mehrizi-Sani and R. Iravani, "Potential-function based control of a microgrid in islanded and grid-connected models," *IEEE Trans. Power Syst.*, vol. 25, pp. 1883–1891, Nov. 2010.
- [11] A. Madureira, C. Moreira, and J. Peças Lopes, "Secondary load-frequency control for microGrids in islanded operation," in *Proc. ICREPQ*, Frankfurt, Germany, 2005, pp. 1–4.
- [12] J. M. Guerrero, P. Loh, M. Chandorkar, T. Lee, "Advanced Control Architectures for Intelligent MicroGrids – Part I: Decentralized and Hierarchical Control," *IEEE Trans. Ind. Electron.*, 2012, Early access.

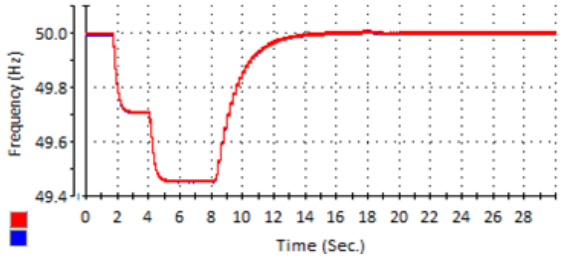
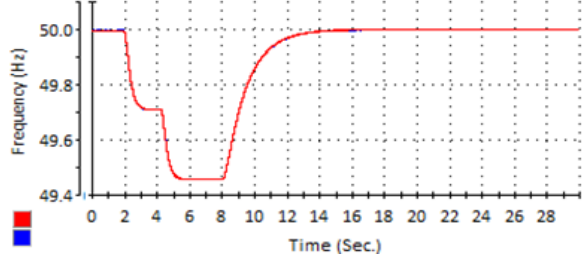
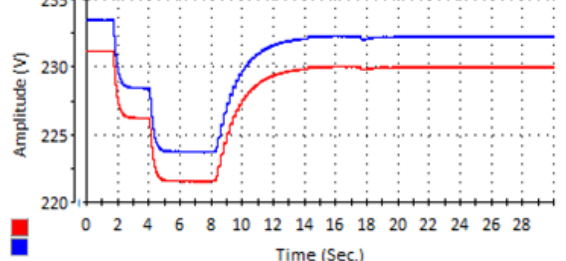
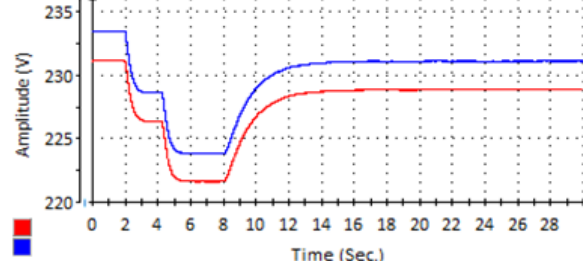
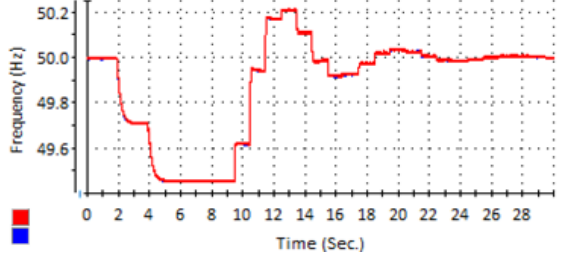
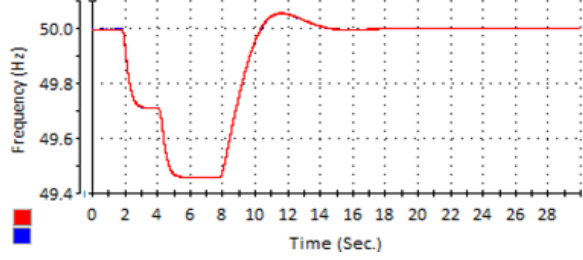
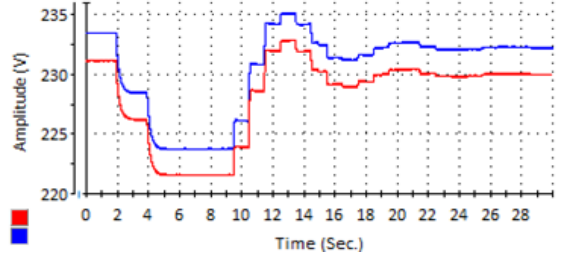
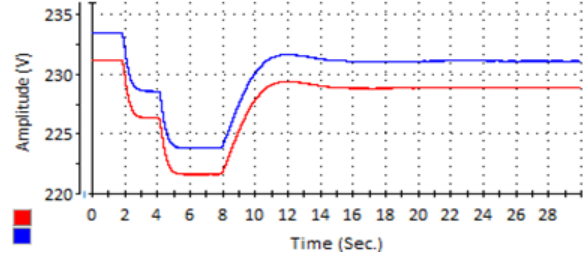
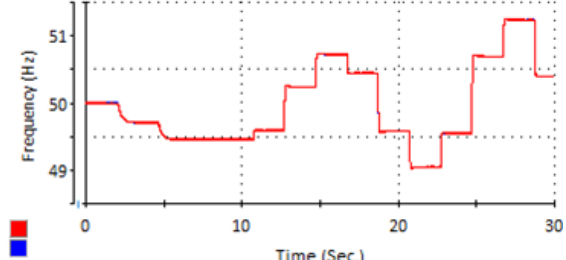
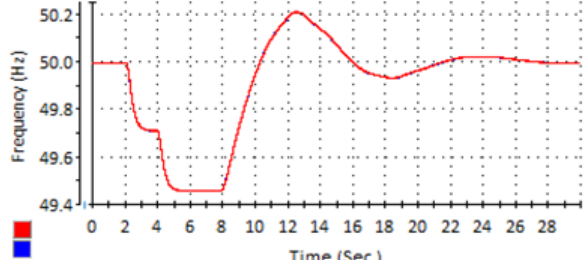
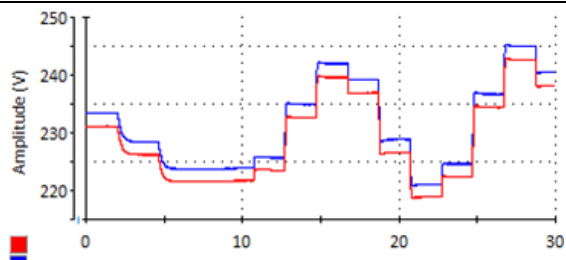
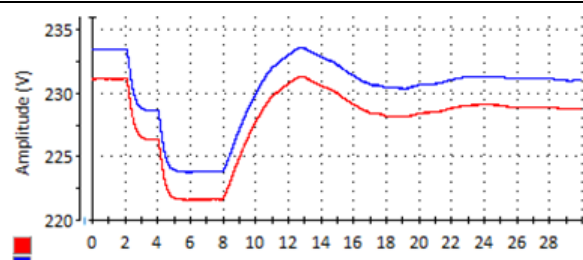
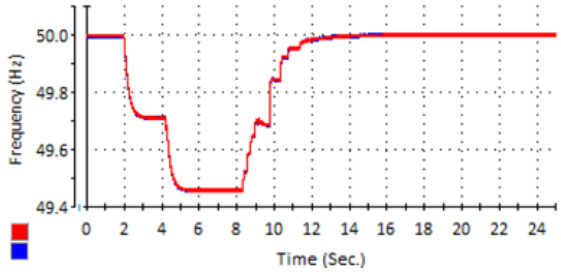
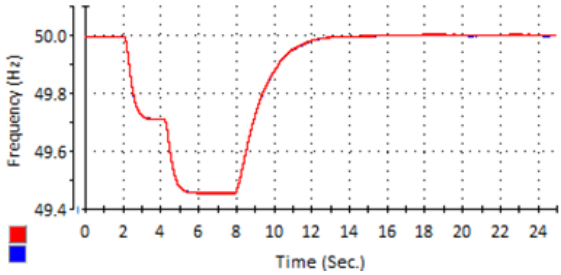
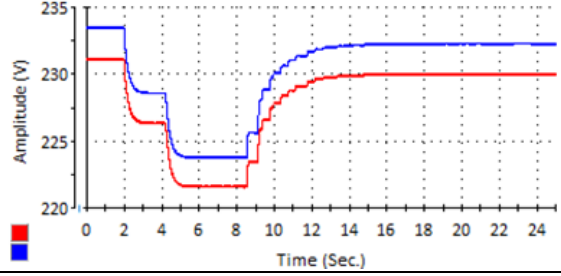
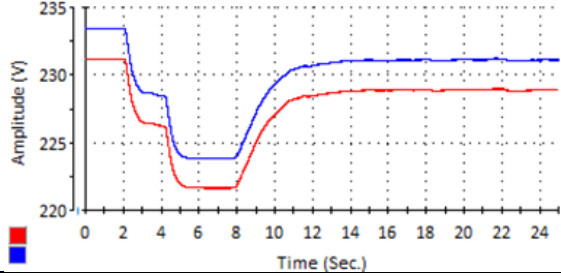
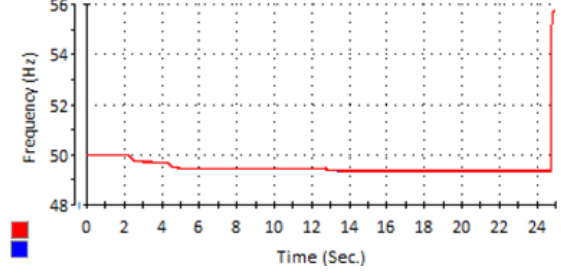
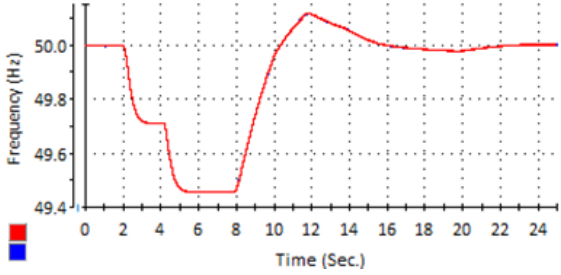
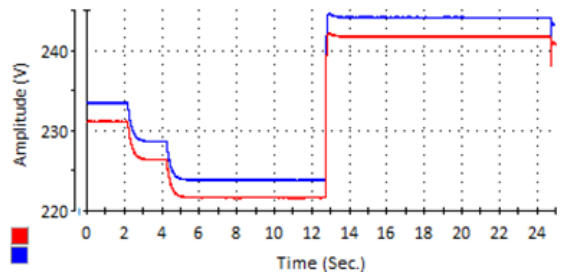
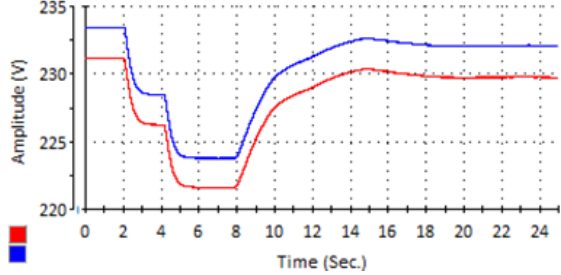
- [13] J. Vasquez, J. M. Guerrero, M. Savaghebi, J. Eloy-Garcia, R. Teodorescu, "Modeling, Analysis, and Design of Stationary Reference Frame Droop Controlled Parallel Three-Phase Voltage Source Inverters," *IEEE Trans. Ind. Electron.*, 2012, Early access.
- [14] B. H. Bakken, O. S. Grande, "Automatic generation control in a deregulated power system," *IEEE Trans. Power Syst.*, vol.13, no.4, pp.1401-1406, Nov 1998.
- [15] H. Bevrani, *Robust Power System Frequency Control*, Springer, New York, USA, 2009.
- [16] M. Savaghebi, A. Jalilian, J. C. Vasquez, J. M. Guerrero, "Secondary Control Scheme for Voltage Unbalance Compensation in an Islanded Droop-Controlled Microgrid," *IEEE Trans. Smart Grid*, vol.3, no.99, pp.1-11, 2011.
- [17] M. Savaghebi, A. Jalilian, J. C. Vasquez, and Josep M. Guerrero, "Secondary Control for Voltage Quality Enhancement in Microgrids," *IEEE Transactions on Smart Grid*, vol. 3, no. 4, pp. 1893-1902, Dec. 2012.
- [18] A. Tuladhar, Jin Hua, T. Unger, K. Mauch, "Control of parallel inverters in distributed AC power systems with consideration of line impedance effect," *IEEE Trans. Ind. Appl.*, vol.36, no.1, pp.131-138, Jan/Feb 2000.
- [19] A. Micallef, M. Apap, C. Spiteri-Staines, J. M. Guerrero "Secondary Control for Reactive Power Sharing in Droop-Controlled Islanded MicroGrids" IEEE ISIE, 2012.
- [20] Y. W. Li and C. N. Kao, "An Accurate Power Control Strategy for Power-Electronics-Interfaced Distributed Generation Units Operating in a Low-Voltage Multibus Microgrid," *IEEE Trans. Power Electron.*, vol.24, no.12, pp.2977-2988, Dec. 2009.
- [21] C. K. Sao, P. W. Lehn, "Autonomous load sharing of voltage source converters," *IEEE Trans. Power Del.*, vol.20, no.2, pp. 1009- 1016, April 2005.
- [22] A. Haddadi, A. Shojaei, B. Boulet, "Enabling high droop gain for improvement of reactive power sharing accuracy in an electronically-interfaced autonomous microgrid," *IEEE/ECCE*, pp.673-679, 17-22 Sept. 2011
- [23] S. K. Mazumder, M. Tahir, K. Acharya, "Pseudo-decentralized control-communication optimization framework for microgrid: A case illustration," *T&D. IEEE/PES*, pp.1-8, 21-24 April 2008.
- [24] Y. Zhang and H. Ma, "Theoretical and Experimental Investigation of Networked Control for Parallel Operation of Inverters," *IEEE Trans. Ind. Electron.*, vol.59, no.4, pp.1961-1970, April 2012.
- [25] J. M. Guerrero, J. C. Vasquez, J. Matas, M. Castilla, and L. G. de Vicuna, "Control strategy for flexible microgrid based on parallel line-interactive UPS systems," *IEEE Trans. Ind. Electron.*, vol. 56, no. 3, pp. 726-736, Mar. 2009.
- [26] M. C. Chandorkar, D. M. Divan, and R. Adapa, "Control of parallel connected inverters in standalone ac supply systems," *IEEE Trans. Ind. Appl.*, vol. 29, no. 1, pp. 136-143, Jan./Feb. 1993.
- [27] J. M. Guerrero, J. Matas, L. G. D. Vicuna, M. Castilla, and J. Miret, "Wireless-control strategy for parallel operation of distributed generation inverters," *IEEE Trans. Ind. Electron.*, vol. 53, pp. 1461-1470, Oct. 2006.
- [28] J. M. Guerrero, J. Matas, L. G. D. Vicuna, M. Castilla, and J. Miret, "Decentralized control for parallel operation of distributed generation inverters using resistive output impedance" *IEEE Trans. Ind. Electron.*, vol. 54, pp. 994-1004, Apr. 2007.
- [29] F. Katiraei and M. R. Iravani, "Power management strategies for a microgrid with multiple distributed generation units," *IEEE Trans. Power Syst.*, vol. 21, pp. 1821-1831, Jan. 2005.
- [30] Y. Guan, Y. Wang, Z. Yang, R. Cao, and H. Xu, "Control strategy for autonomous operation of three-phase inverters dominated microgrid under different line impedance," *IEEE/ICEMS*, pp. 1-5, 2011.
- [31] C. L. Moreira, F. O. Resende, and J. A. P. Lopes, "Using low voltage microgrids for service restoration," *IEEE Trans. Power Syst.*, vol. 22, no. 1, pp. 395-403, Feb. 2007.



systems and power quality in MicroGrids.

Qobad Shafiee received the B.S. degree from Razi University, Iran, in 2004 and the M.S. degree from Iran University of Science and Technology (IUST), in 2007, both in electrical engineering. He worked with department of electrical and computer engineering in University of Kurdistan from 2007 to 2011, where he has been teaching some electrical engineering courses. He is now perusing the Ph.D. degree in the department of energy technology at Aalborg University. His main research interests include hierarchical control, networked control



Josep M. Guerrero (S'01-M'04-SM'08) received the B.S. degree in telecommunications engineering, the M.S. degree in electronics engineering, and the Ph.D. degree in power electronics from the Technical University of Catalonia, Barcelona, in 1997, 2000 and 2003, respectively. He was an Associate Professor with the Department of Automatic Control Systems and Computer Engineering, Technical University of Catalonia, teaching courses on digital signal processing, field-programmable gate arrays, microprocessors, and control of renewable energy.

In 2004, he was responsible for the Renewable Energy Laboratory, Escola Industrial de Barcelona. Since 2011, he has been a Full Professor with the Department of Energy Technology, Aalborg University, Aalborg East, Denmark, where he is responsible for the microgrid research program. From 2012 he is also a guest Professor at the Chinese Academy of Science and the Nanjing University of Aeronautics and Astronautics. His research interests is oriented to different microgrid aspects, including power electronics, distributed energy-storage systems, hierarchical and cooperative control, energy management systems, and optimization of microgrids and islanded minigrids. Prof. Guerrero is an Associate Editor for the IEEE TRANSACTIONS ON POWER ELECTRONICS, the IEEE TRANSACTIONS ON INDUSTRIAL ELECTRONICS, and the IEEE Industrial Electronics Magazine. He has been Guest Editor of the IEEE TRANSACTIONS ON POWER ELECTRONICS Special Issues: Power Electronics for Wind Energy Conversion and Power Electronics for Microgrids, and the IEEE TRANSACTIONS ON INDUSTRIAL ELECTRONICS Special Sections: Uninterruptible Power Supplies systems, Renewable Energy Systems, Distributed Generation and Microgrids, and Industrial Applications and Implementation Issues of the Kalman Filter. He was the chair of the Renewable Energy Systems Technical Committee of the IEEE Industrial Electronics Society.



Juan C. Vasquez (M'12) received the B.S. degree in Electronics Engineering from Autonomia University of Manizales, Colombia in 2004 where he has been teaching courses on digital circuits, servo systems and flexible manufacturing systems. In 2009, He received his Ph.D degree from the Technical University of Catalonia, Barcelona, Spain in 2009 at the Department of Automatic Control Systems and Computer Engineering, where he worked as Post-doc Assistant and also teaching courses based on renewable energy systems. Currently, he is an Assistant Professor at Aalborg University in Denmark. His research interests include modeling, simulation, networked control systems and optimization for power management systems applied to Distributed Generation in AC/DC Microgrids.