



Thermal Optimized Operation of the Single-Phase Full-Bridge PV Inverter under Low Voltage Ride-Through Mode

Wang, Huai; Yang, Yongheng; Blaabjerg, Frede

Published in:
Proceedings of PCIM Europe 2013

Publication date:
2013

Document Version
Accepted author manuscript, peer reviewed version

[Link to publication from Aalborg University](#)

Citation for published version (APA):
Wang, H., Yang, Y., & Blaabjerg, F. (2013). Thermal Optimized Operation of the Single-Phase Full-Bridge PV Inverter under Low Voltage Ride-Through Mode. In *Proceedings of PCIM Europe 2013* (pp. 1055-1062). VDE Verlag GMBH.

General rights

Copyright and moral rights for the publications made accessible in the public portal are retained by the authors and/or other copyright owners and it is a condition of accessing publications that users recognise and abide by the legal requirements associated with these rights.

- Users may download and print one copy of any publication from the public portal for the purpose of private study or research.
- You may not further distribute the material or use it for any profit-making activity or commercial gain
- You may freely distribute the URL identifying the publication in the public portal -

Take down policy

If you believe that this document breaches copyright please contact us at vbn@aub.aau.dk providing details, and we will remove access to the work immediately and investigate your claim.

Thermal Optimized Operation of the Single-Phase Full-Bridge PV Inverter under Low Voltage Ride-Through Mode

Yongheng Yang, Huai Wang, Frede Blaabjerg

Center Of Reliable Power Electronics (CORPE), Department of Energy Technology, Aalborg University

Nuremberg, 14 – 16 May 2013

Abstract- The efficiency of 98% has been reported on transformer-less photovoltaic (PV) inverters and the penetration of grid-connected PV systems is booming as well. In the future, the PV systems are expected to contribute to the grid stability by means of low voltage ride-through operation and grid support. At the same time, the target of a long service time (25 years or more) imposes new challenges to grid-connected transformer-less PV systems. Achieving more reliable PV inverters is of intense interest in recent research. As one of the most critical stresses that induce failures, the thermal stresses on the power devices of a single-phase full-bridge PV inverter are analyzed in different operational modes in this paper. The low voltage grid condition is specially taken into account in this paper. The analysis is demonstrated by a 3 kW single-phase full-bridge grid-connected PV system by simulations. **The mean junction temperature and the junction temperature fluctuation of the power devices can be reduced by properly injecting reactive current into the grid under grid faults, and consequently, the overall lifetime of the entire PV system is improved.**

Introduction

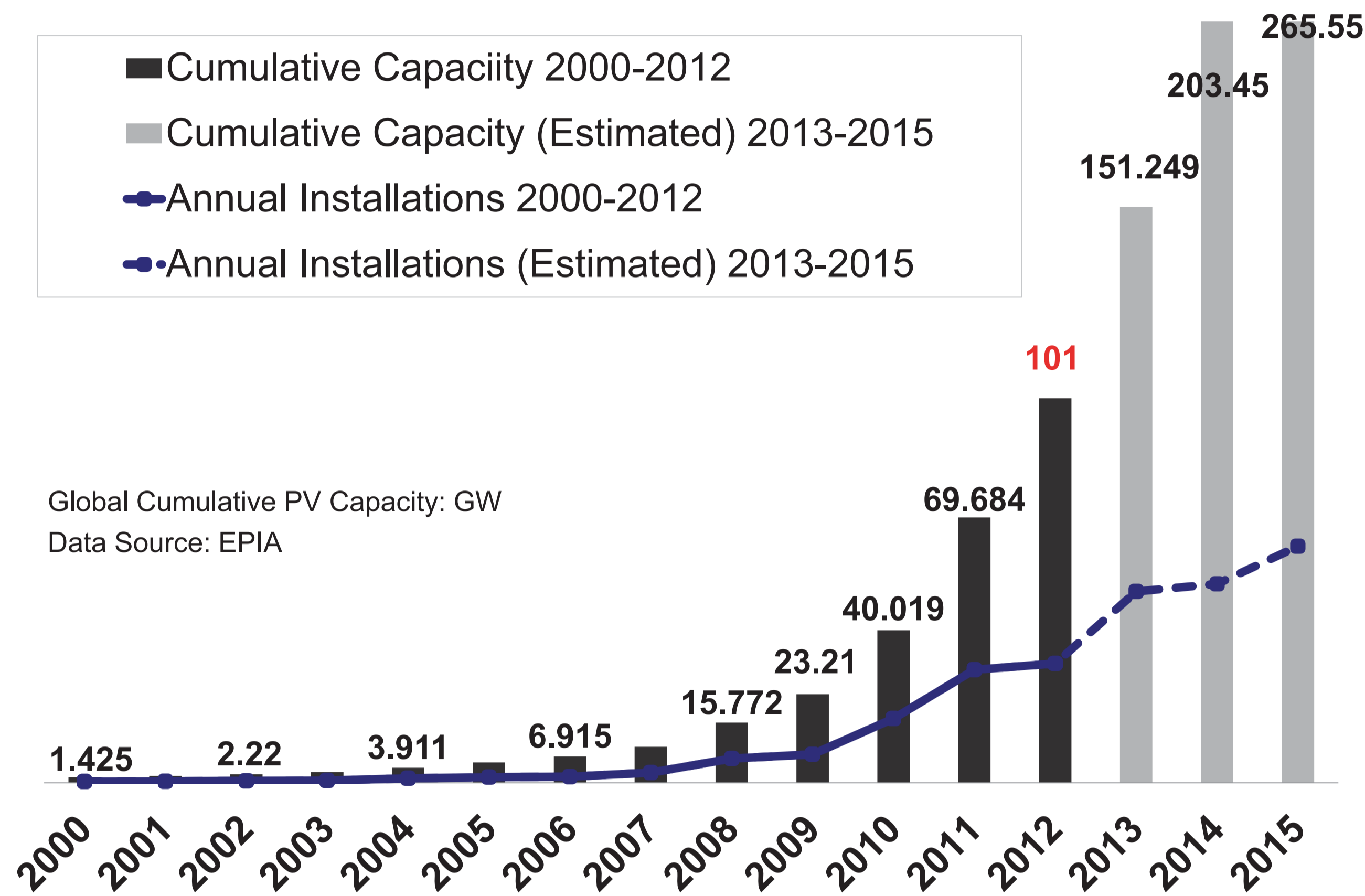

Highly Penetrated PV Systems in the Grid in the Future:

- ❖ More Stringent Grid Requirements
- ❖ Ancillary Services (Grid Support, Reactive Power Compensation)
- ❖ Dynamic Grid Support (**Low Voltage Ride-Through**)
- ❖ High Efficiency and **High Reliability**

Thermal Models of the Full-Bridge PV Inverter

Typical Single-Phase PV System with Low Voltage Ride-Through Capability

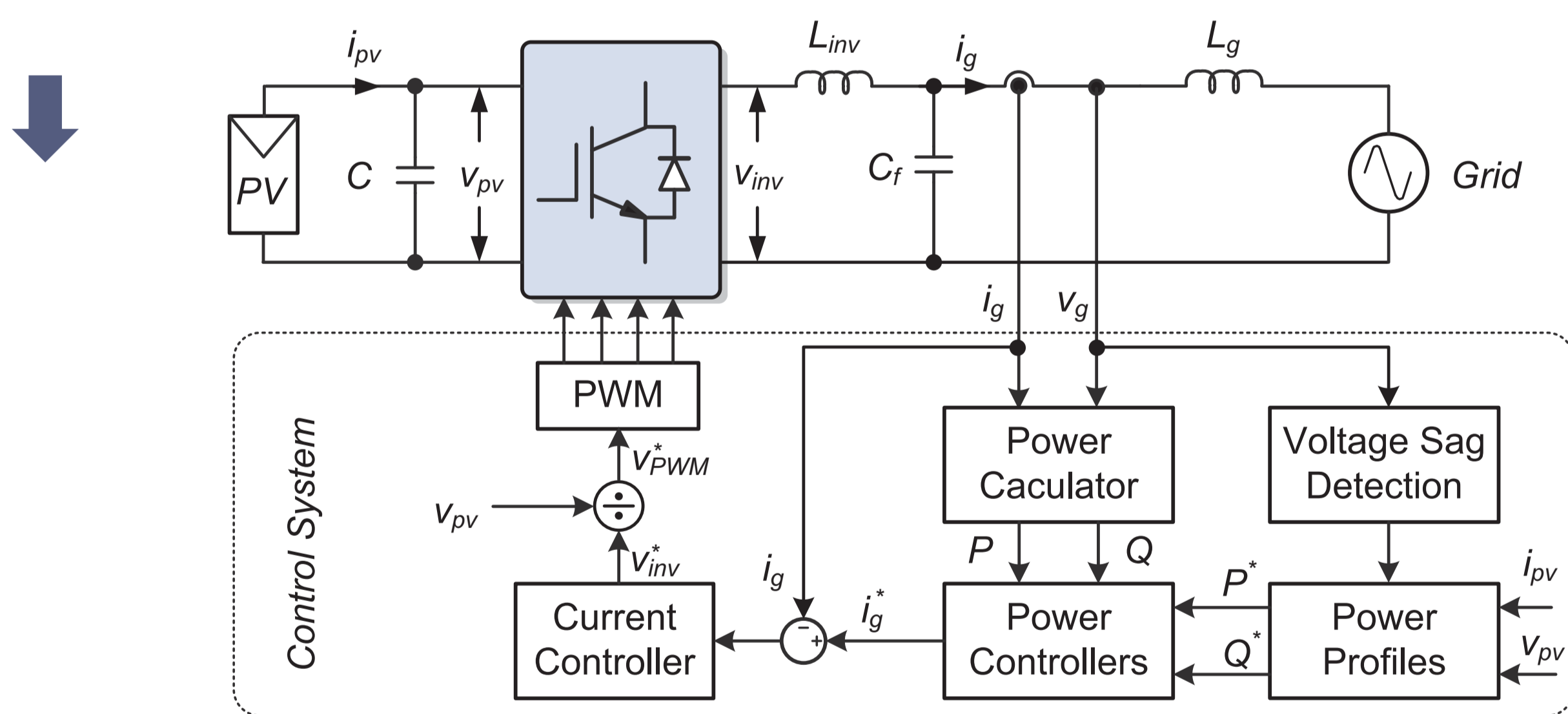

Thermal Model of an IGBT Module

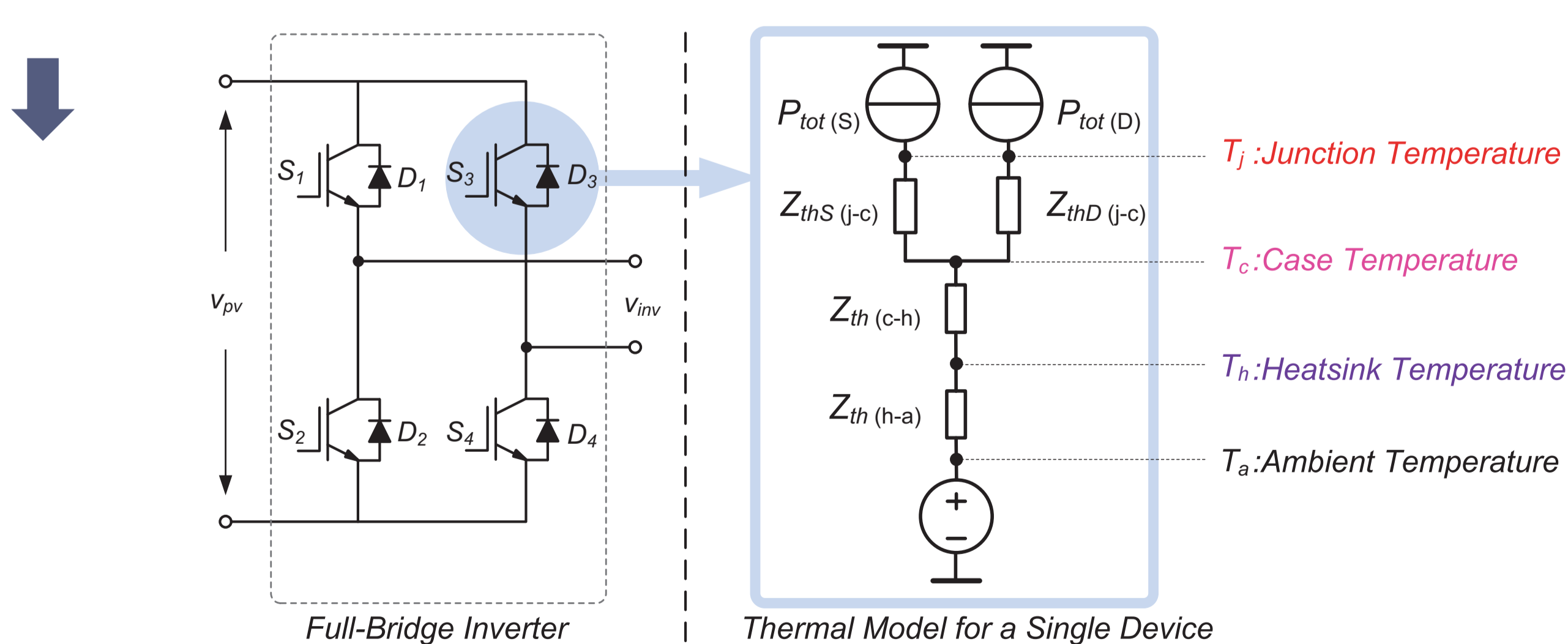

Thermal Model of the Thermal Impedance

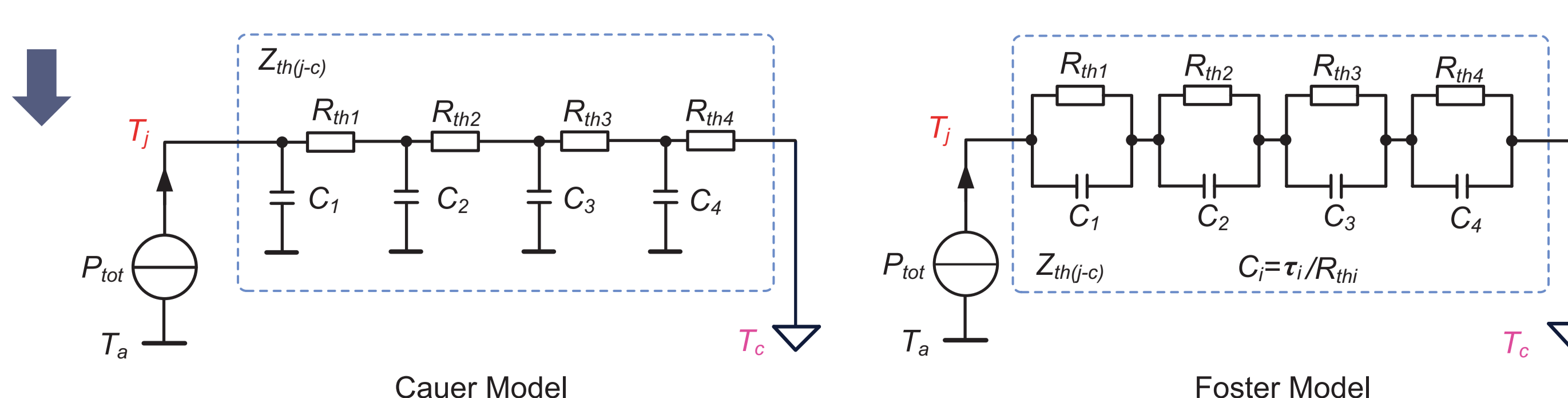

Thermal Optimized Operation Mode

Operation Condition: Solar Irradiance: 1000 W/m², Ambient Temperature: 50 °C

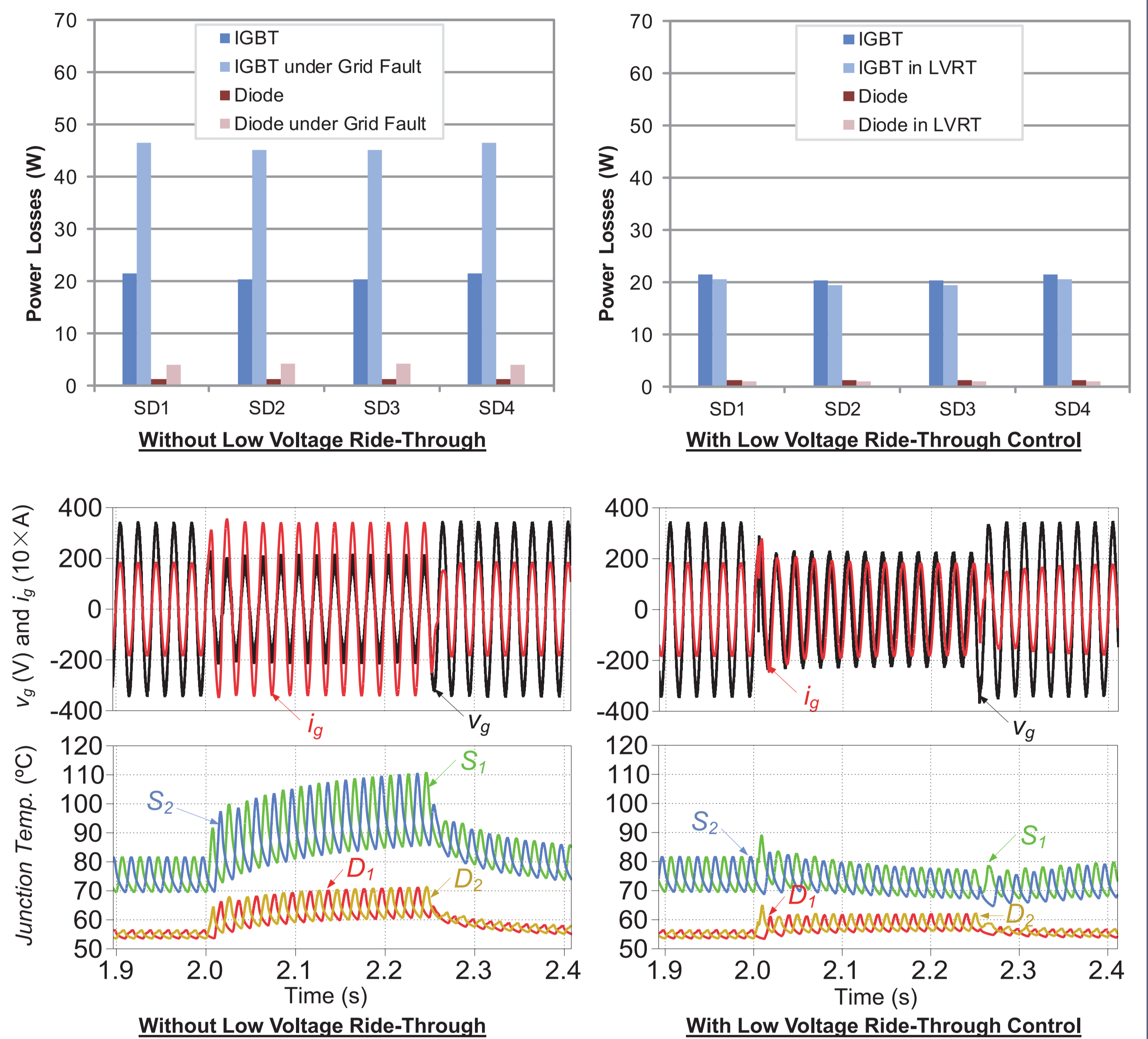

With Thermal Optimized Operation Control:

- ✓ Reduction of Power Losses under Grid Faults and Low Junction Temperature
- ✓ Reduced Junction Temperature Variation from 24 °C to 10 °C

System Operation under Different Power Levels

In Normal Operation Mode

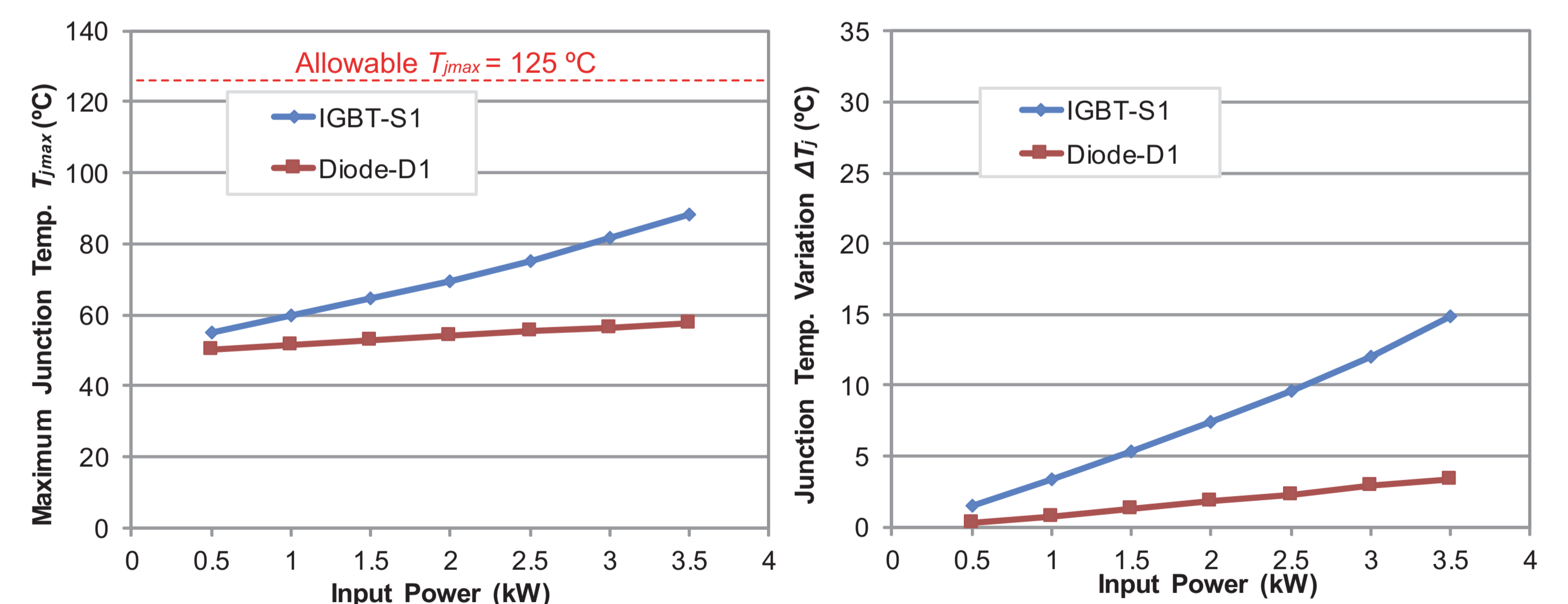

Under Grid Fault (0.45 p.u. Voltage Sag)

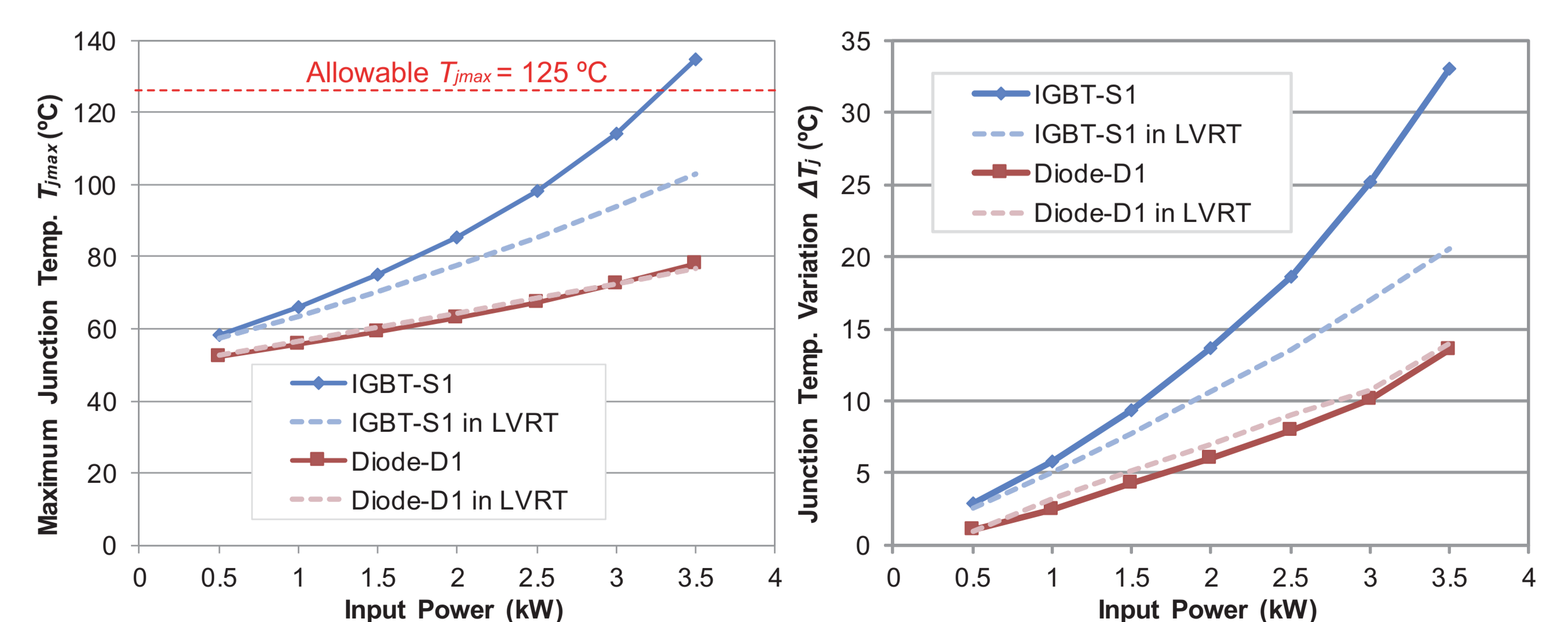

With Thermal Optimized Operation Control:

- ✓ Maximum Junction Temperature below the Allowable Value

