



Frequency Adaptive Repetitive Control of Grid-Tied Single-Phase PV Inverters

Zhou, Keliang; Yang, Yongheng; Blaabjerg, Frede

Published in:

Proceedings of the 2015 IEEE Energy Conversion Congress and Exposition (ECCE)

DOI (link to publication from Publisher):

[10.1109/ECCE.2015.7309898](https://doi.org/10.1109/ECCE.2015.7309898)

Publication date:

2015

Document Version

Early version, also known as pre-print

[Link to publication from Aalborg University](#)

Citation for published version (APA):

Zhou, K., Yang, Y., & Blaabjerg, F. (2015). Frequency Adaptive Repetitive Control of Grid-Tied Single-Phase PV Inverters. In *Proceedings of the 2015 IEEE Energy Conversion Congress and Exposition (ECCE)* (pp. 1689 - 1693). IEEE Press. <https://doi.org/10.1109/ECCE.2015.7309898>

General rights

Copyright and moral rights for the publications made accessible in the public portal are retained by the authors and/or other copyright owners and it is a condition of accessing publications that users recognise and abide by the legal requirements associated with these rights.

- Users may download and print one copy of any publication from the public portal for the purpose of private study or research.
- You may not further distribute the material or use it for any profit-making activity or commercial gain
- You may freely distribute the URL identifying the publication in the public portal -

Take down policy

If you believe that this document breaches copyright please contact us at vbn@aub.aau.dk providing details, and we will remove access to the work immediately and investigate your claim.

Frequency Adaptive Repetitive Control of Grid-Tied Single-Phase PV Inverters

Keliang Zhou^{†1}, Senior Member, IEEE, Yongheng Yang^{‡2}, Member, IEEE, and Frede Blaabjerg^{‡3}, Fellow, IEEE

[†]School of Engineering
University of Glasgow
Glasgow, UK

¹keliang.zhou@glasgow.ac.uk

[‡]Department of Energy Technology
Aalborg University
Aalborg, Denmark
²yoy@et.au.dk; ³fb1@et.au.dk

Abstract— The internal model principle based Repetitive Control (RC) offers an accurate control strategy for grid-tied power converters to feed sinusoidal current into the grid. However, in the presence of grid frequency variations, the conventional RC fails to produce high quality feeding current. This paper thus explores a frequency adaptive repetitive control strategy for grid converters, which employs fractional delay filters in order to adapt to the change of the grid frequency. Case studies with experimental results of a single-phase grid-connected PV inverter system are provided to verify the proposed controller.

Keywords— frequency adaptive; power converter; repetitive control; fractional delay filter; PV inverters

I. INTRODUCTION

According to the internal model principle, a Repetitive Controller (RC) [1]-[8] can achieve zero steady-state error tracking of any periodic signal with known period due to the introduction of high gains at the interested harmonic frequencies. It offers a very simple but effective and accurate control solution for power converters to produce high quality sinusoidal voltages/currents. The conventional RC controller in its digital form of $z^{-N}/(1-z^{-N})$ can track any periodic reference signal with an integer period of $N=f_s/f$, where f is the fundamental frequency of reference signal and f_s is the sampling rate. However, in grid-connected applications, the grid frequency is usually variable in a certain range (e.g., 49 Hz ~ 51 Hz) in practice and specified in the grid codes. Thus N would often be fractional in the case of a fixed sampling rate f_s . Since only z^{-N} with an integer N can be implemented in practice, the conventional RC is sensitive to grid frequency variations, and it thus cannot exactly compensate periodic voltages/currents of variable frequency. Ensuring the integer period of N is always the same in the presence of grid frequency variations, the variable sampling rate approach enables the RC to reject harmonics completely [9]-[15]. However, a variable sampling rate will significantly increase the real-time implementation complexity of the control systems, such as online controller redesign [16], [17].

In order to address this issue, a frequency adaptive RC strategy at fixed sampling rate is proposed to for grid-tied converters to feed sinusoidal current into grid in the presence of a variable grid frequency. The fractional delay z^{-N} with a

fractional number N will be replaced with an approximated Finite Impulse Response (FIR) fractional delay filter. The proposed FIR fractional delay filter only consumes a small number of multiplications and additions to update its coefficients, and it is well suited to fast online tuning of the fractional delay. The proposed frequency adaptive RC will enable grid-tied converters always to produce sinusoidal feeding currents under variable grid frequency. The analysis and synthesis of such frequency adaptive RC systems are addressed. Case studies of grid-tied converters are provided to evaluate the proposed frequency adaptive RC.

II. FREQUENCY ADAPTIVE REPETITIVE CONTROL

Fig. 1 shows the typical closed-loop control system with a plug-in Conventional Repetitive Controller (CRC), where $R(z)$ is the reference input, $Y(z)$ is the output, $E(z) = R(z) - Y(z)$ is the tracking error, $D(z)$ is the disturbance, $G_p(z)$ is the plant, $G_c(z)$ is the conventional feedback controller, $G_r(z)$ is a feed-forward plug-in CRC, k_r is the RC gain, $U_r(z)$ is the output of the CRC, $G_f(z)$ is a phase lead compensation filter to stabilize the overall closed-loop system [18]-[22], and $Q(z) = a_1z + a_0 + a_1z^{-1}$ with $2a_1 + a_0 = 1$ is a low pass filter to enhance the entire control system robustness [12].

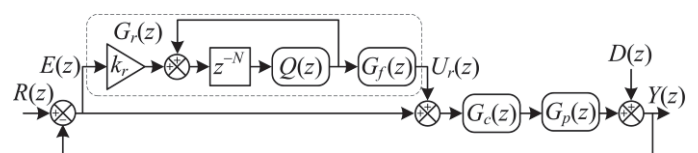

Fig. 1. Plug-in repetitive control system in a general converter structure.

The transfer function $G_r(z)$ of the plug-in CRC shown in Fig. 1 can be written as

$$G_r(z) = \frac{U_r(z)}{E(z)} = k_r \frac{z^{-N} Q(z)}{1 - z^{-N} Q(z)} G_f(z) \quad (1)$$

where $N=f_s/f \in \mathbb{N}$ with f being the fundamental frequency of the reference signal $R(z)$ and/or disturbance $D(z)$, and f_s being the sampling rate, N is the order of the RC; the poles of $G_r(z)$ are located around $2m\pi f$, with $m=0, 1, 2, \dots, M$ ($M=N/2$ for an even N and $M=(N-1)/2$ for an odd N). It is clearly seen

that the amplitudes of $G_r(z)$ at frequencies $2m\pi f$ approach infinity if $Q(z)=1$. Consequently, the CRC provides zero steady-state error tracking of all harmonic components below the Nyquist frequency if $Q(z)=1$ and its order N is an integer [6]-[8]. Moreover, z^{-N} with an integer N can be easily implemented in practice. However, in the case of a time-varying frequency f , $N = f_s/f$ would often be fractional with a fixed sampling rate f_s . As a result, high control gains will be shifted away from the interested harmonic frequencies. Thus, the CRC is sensitive to the change of the grid frequency f .

In order to adapt to a variable frequency f , the fractional delay term of z^{-N} can be approximated by Fractional Delay (FD) filters [23]-[28]. Assuming that $z^{-N} = z^{-N_i - F}$ with $N_i = [N]$ being the integer part of N and $F = N - N_i$ ($0 \leq F < 1$) being the fractional part of N , the fractional delay z^{-F} can thus be approximated by a Lagrange interpolation polynomial FIR filter as given in the following [23]-[26]

$$z^{-F} \approx \sum_{k=0}^n A_k z^{-k} \quad (2)$$

where $k = 0, 1, \dots, n$, and A_k are the interpolation polynomial coefficients that can be given as

$$A_k = \prod_{\substack{i=0 \\ i \neq k}}^n \frac{F-i}{k-i} \quad k, i = 0, 1, \dots, \quad (3)$$

It should be noted that, if $n = 1$ in (2), a linear interpolation polynomial $z^{-F} \approx (1-F) + Fz^{-1}$ will be attained.

Substituting (2) and (3) into (1), a Frequency Adaptive RC (FARC) will be obtained as

$$G_{fr}(z) = \frac{U_r(z)}{E(z)} = k_r \frac{z^{-N_i} \sum_{k=0}^n A_k z^{-k} Q(z)}{1 - z^{-N_i} \sum_{k=0}^n A_k z^{-k} Q(z)} G_f(z) \quad (4)$$

which will become the CRC of (1) when $F = 0$. The FARC of (4) provides a general approach to track or eliminate any periodic signal with an arbitrary fundamental frequency. It should be pointed out that both N_i and F should change slowly in practical applications.

Fig. 2 shows the magnitude responses of the Lagrange interpolation based FD filter of (2) with the order $n = 1$ and $n = 3$ for various fractional F from 0 to 0.9. It is seen that the FD filter of (2) with order $n = 3$ gives an excellent approximation of the fractional delay z^{-F} at low frequencies within the bandwidth of 75 % of the Nyquist frequency. In contrast, the bandwidth of 50 % of the Nyquist frequency is observed for the FD filter of order $n = 1$.

Notably, the Lagrange interpolation is one of the easiest ways to design a FD filter to approximate a given fractional delay. Moreover, the coefficient of (2) for the FD filter only consumes a small number of additions and multiplications for a fast online update of the coefficients. Such an FIR FD filter-based FARC offers an attractive method for the real-time control of high switching-frequency grid-tied converters.

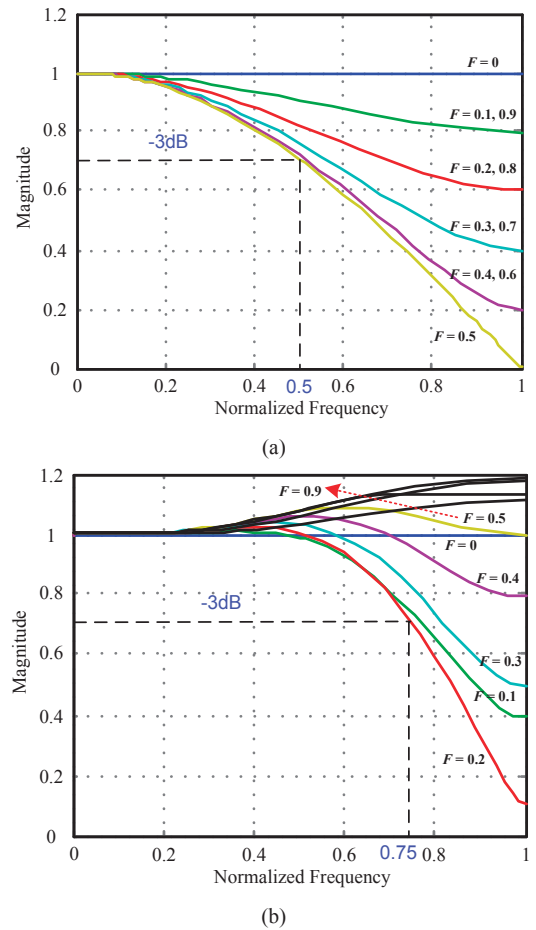

Fig. 2. Frequency responses of the Lagrange interpolation based fractional delay filters with different F , where the frequency is normalized taking the Nyquist frequency as the base value: (a) $n = 1$ and (b) $n = 3$.

III. CASE STUDY: GRID-TIED SINGLE-PHASE PV INVERTER

Fig. 3 shows a grid-connected single-phase inverter for PV applications with an LCL -filter, which is used to feed currents into the grid. The inner current control loop comprises a deadbeat feedback and the proposed plug-in FARC controller. The outer control loop is responsible for generating accurate current references for the inner control loop [1].

A. Modeling and Control

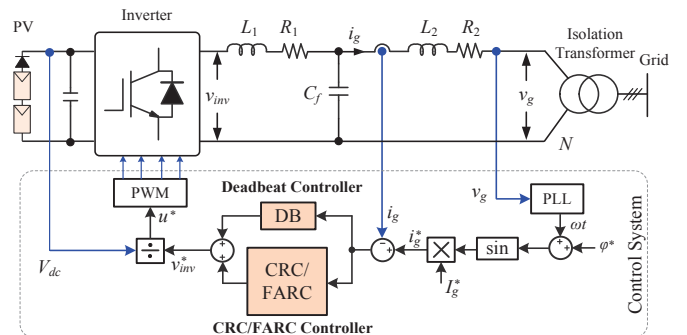

Fig. 3. Schematic and overall control structure of a single-phase single-stage grid-connected PV inverter system with an LCL filter (PLL – Phase Locked Loop, PWM – Pulse Width Modulation).

As it is shown in Fig. 3, the capacitor C_f is used to eliminate high-order harmonic currents of switching frequencies, and together with the grid-side inductor L_2 , it is referred to as an “ideal” load. Hence, the dynamics of the PV inverter can simply be described as

$$L_1 \frac{di_g}{dt} = -R_1 i_g + (v_{inv} - v_g) \quad (5)$$

where v_g is the grid voltages, i_g is the grid currents, L_1 and R_1 are the nominal values of ac-side inductor (L_1) and resistor (R_1) of the LCL filter, respectively.

One control objective of the inverter is typically to achieve a unity power factor and thus a Second-Order Generalized Integrator based Phase Locked loop (PLL) system [29] is adopted. The second objective is to maintain a low harmonic distortion sinusoidal current using advanced control schemes.

The sampled-data model of (5) can be written as

$$i_g(k+1) = \frac{b_1 - b_2}{b_1} i_g(k) + \frac{u(k)}{b_1} v_{dc}(k) - \frac{v_g(k)}{b_1} \quad (6)$$

where $b_1 = L_1/T_s$, $b_2 = R_1$, u is the modulation signal with $v_{inv}(t) = u(t)v_{dc}(t)$, and T_s is the sampling period.

For the plant in (6), a Dead-Beat (DB) current controller is adopted as

$$u(k) = \frac{1}{v_{dc}(k)} \left[v_g(k) + b_1 i_{gref}(k) - (b_1 - b_2) i_g(k) \right] \quad (7)$$

which makes $i_g(k+1) = i_{gref}(k)$. As it is shown in Fig. 3, the CRC $G_r(z)$ and the proposed FARC $G_{fr}(z)$ of (4) are plugged into the current control loop to ensure high accuracy current tracking.

For the FARC of (4), $n = 3$ is chosen to be the Lagrange polynomial degree. Hence, the corresponding fractional delay will be

$$z^{-N} = A_0 z^{-N_i} + A_1 z^{-N_i-1} + A_2 z^{-N_i-2} + A_3 z^{-N_i-3} \quad (8)$$

B. Experimental Setup

A test rig is built-up, where a single-phase commercial power converter is connected to the grid through an LCL -filter, and the control system was implemented in a dSPACE DS 1103 rapid prototyping kit. Parameters of the test setup are listed in Table I. To achieve approximately zero phase compensation, a filter $G_f(z) = z^p$ is used to compensate sampling delays, model mismatches, and un-modeled delay, where the lead step $p = 3$ is determined by experiments.

TABLE I.
SYSTEM PARAMETERS OF A SINGLE-PHASE GRID-TIED INVERTER SYSTEM.

LCL-filter	$L_1 = L_2 = 3.6$ mH, $C_f = 2.35$ μ F,
Transformer leakage inductance	$L_g = 2$ mH
Switching and sampling frequency	$f_s = f_{sw} = 10$ kHz
DC voltage	$V_{dc} = 400$ V
Power rating	$P_n = 1$ kW
Nominal grid voltage v_g	50 Hz, 325 V (peak)
Grid current reference i_g^*	5 A (peak) at unity power factor
Repetitive control gain	$k_{rc} = 1.8$
Low pass filter $Q(z)$	$0.175z^{-1} + 0.65 + 0.175z$

C. Experimental Results

Fig. 4 gives the steady-state responses of the DB plus CRC controlled single-phase inverter. It can be seen that the CRC is sensitive to the change of the grid frequency f – when f drops from nominal 50 Hz to 49 Hz, the Total Harmonic Distortion (THD) of the feeding current i_g increases from 1.4% to 6.25%; when f rises from nominal 50 Hz to 51 Hz, the THD of feeding current i_g increases from 1.4% to 6.5%. Then, the FARC controller is added to improve the current control.

Fig. 5 gives the steady-state responses of the DB plus FARC controlled single-phase inverter. It can be seen that the CRC is much less sensitive to the change of the grid frequency f . Specifically, when f drops from nominal 50 Hz to 49 Hz, the THD of feeding current i_g increases from 1.4% to 3.10%; when f rises from nominal 50 Hz to 51 Hz, the THD of feeding current i_g increases from 1.4% to 3.16%.

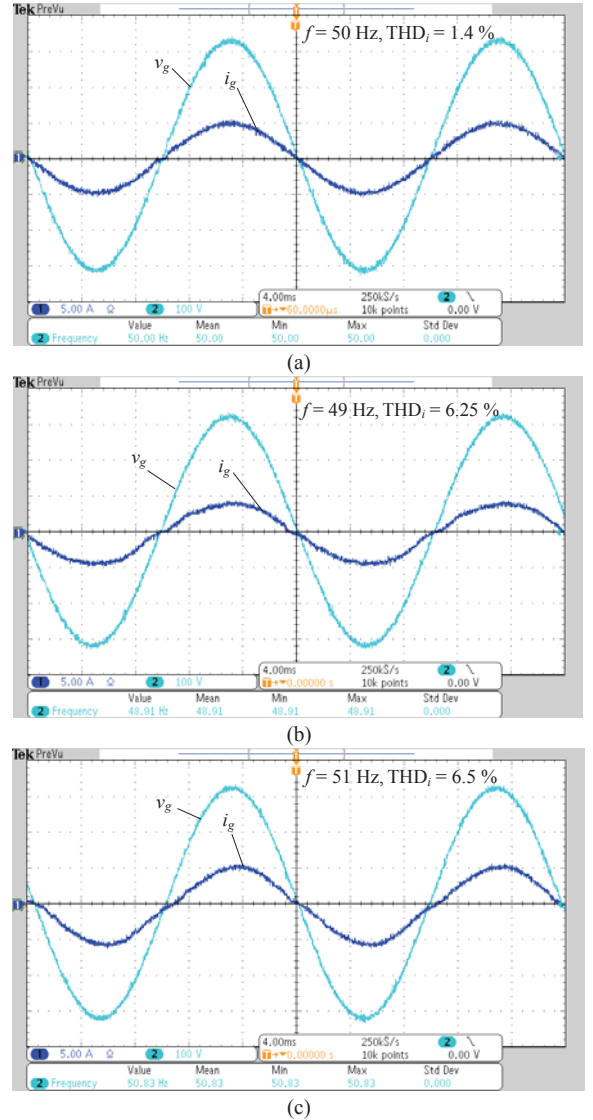

Fig. 4. Steady-state responses of the DB plus CRC controlled single-phase inverter system (grid voltage v_g [100 V/div]; grid current i_g [5 A/div]; time [4 ms/div]): (a) $f = 50$ Hz, $N = 200$, THD of $i_g = 1.4\%$, (b) $f = 49$ Hz, $N = 200$, THD of $i_g = 6.25\%$, and (c) $f = 51$ Hz, $N = 200$, THD of $i_g = 6.5\%$.

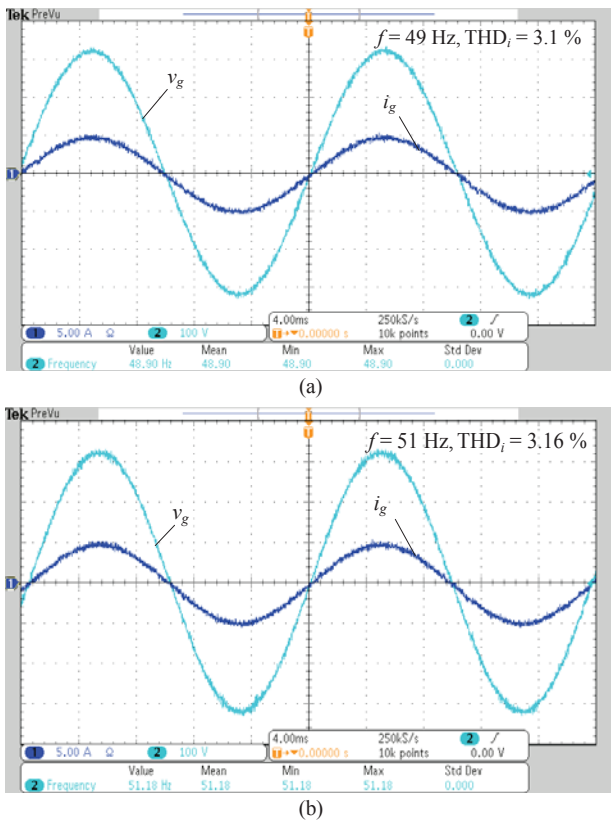

Fig. 5. Steady-state responses of the DB plus FARC controlled single-phase inverter system (grid voltage v_g [100 V/div]; grid current i_g [5 A/div]; time [4 ms/div]): (a) $f = 49$ Hz, THD of $i_g = 3.1\%$ and (b) $f = 51$ Hz, THD of $i_g = 3.16\%$.

Furthermore, the THD of the feeding current with these two repetitive control schemes under various grid frequencies is shown in Fig. 6. It can be observed that the FARC can ensure a satisfactory feeding current quality with $\text{THD} < 5\%$ in the presence of time-varying grid frequency, but the CRC cannot maintain a lower THD in the case of grid frequency variations. Additionally, Fig. 7 shows that the FARC controlled inverter keeps feeding almost constant good quality current into the grid regardless of the step-changes of the grid frequency between 49.5 Hz to 50.5 Hz. This further confirms the effectiveness of the FARC in terms of dynamics.

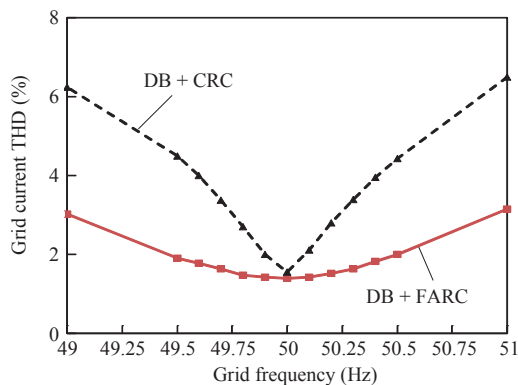

Fig. 6. THD of the feeding current i_g of the CRC and FARC controlled single-phase grid-tied system under various grid frequencies.

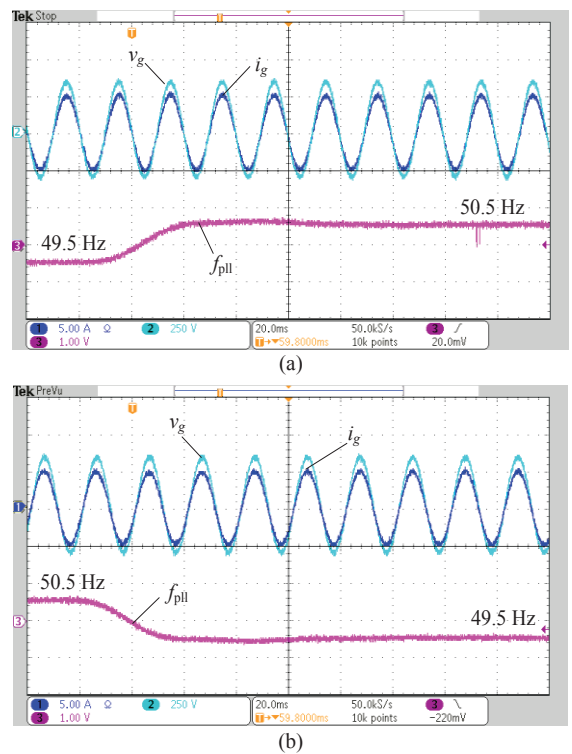

Fig. 7. Dynamic performance of the DB plus FARC controlled single-phase inverter system (grid voltage v_g [250 V/div]; grid current i_g [5 A/div]; PLL estimated grid frequency f_{pll} [1 Hz/div]; time [20 ms/div]): (a) the grid frequency changed from 49.5 Hz to 50.5 Hz and (b) the grid frequency changed from 50.5 Hz to 49.5 Hz.

IV. CONCLUSIONS

A frequency adaptive repetitive control method has been proposed for grid-tied converters to feed sinusoidal currents into electricity network in the presence of a time-varying grid frequency. The proposed frequency adaptive repetitive control scheme offers a fast on-line tuning of the fractional delay and a fast update of the coefficients. It provides to grid-tied converters with a simple but very accurate control solution under grid frequency variations. An application example of grid-tied single-phase PV inverters has presented to demonstrate the effectiveness and advantages of the proposed frequency adaptive repetitive control solution.

REFERENCES

- [1] F. Blaabjerg, M. Liserre, R. Teodorescu, A.V. Timbus "Overview of Control and Grid Synchronization for Distributed Power Generation Systems." *IEEE Trans. Ind. Electron.*, vol. 53, no. 5, pp. 1398-1409, 2006.
- [2] P. C. Loh, Y. Tang, F. Blaabjerg, and P. Wang, "Mixed-frame and stationary-frame repetitive control schemes for compensating typical load and grid harmonics," *IET Power Electron.*, vol. 4, no. 2, pp. 218-226, 2011.
- [3] K. Zhou, Z. Qiu, N.R. Watson, and Y. Liu, "Mechanism and elimination of harmonic current injection from single-phase grid-connected PWM converters," *IET Power Electronics*, vol. 6, no. 1, pp. 88-95, 2013.
- [4] L. He, K. Zhang, J. Xiong, and S. Fan, "A repetitive control scheme for harmonic suppression of circulating current in modular multilevel converters," *IEEE Trans. Power Electron.*, vol. 30, no. 1, pp. 471-481, Jan. 2015.

- [5] S. Jiang, D. Cao, Y. Li, J. Liu, and F.Z. Peng, "Low-THD, fast-transient, and cost-effective synchronous-frame repetitive controller for three-phase UPS inverters," *IEEE Trans. Power Electron.*, vol. 27, no. 6, pp. 2994-3005, Jun. 2012.
- [6] K. Zhou and D. Wang, "Zero tracking error controller for three-phase CVCF PWM inverter," *Electronics Letters*, vol. 36, no. 10, pp. 864-865, 2000.
- [7] Q. C. Zhong and T. Hornik, "Cascaded current-voltage control to improve the power quality for a grid-connected inverter with a local load," *IEEE Trans. Ind. Electron.*, vol. 60, no. 4, pp. 1344-1355, 2013.
- [8] K. Zhang, Y. Kang, J. Xiong, and J. Chen, "Direct repetitive control of SPWM inverter for UPS purpose," *IEEE Trans. Power Electron.*, vol. 18, no. 3, pp. 784-792, 2003.
- [9] B. Zhang, K. Zhou, and D. Wang, "Multirate repetitive control for PWM DC/AC converters," *IEEE Trans. Ind. Electron.*, vol. 61, no. 6, pp. 2883-2890, 2014.
- [10] W. Lu, K. Zhou, D. Wang, and M. Cheng, "A general parallel structure repetitive control scheme for multi-phase DC-AC PWM converters," *IEEE Trans. Power Electron.*, vol. 28, no. 8, pp. 3980-3987, 2013.
- [11] W. Lu, K. Zhou, D. Wang, and M. Cheng, "A generic digital $nk \pm m$ order harmonic repetitive control scheme for PWM converters," *IEEE Trans. Ind. Electron.*, vol. 61, no. 3, pp. 1516-1527, 2014.
- [12] W. Zhu, K. Zhou, and M. Cheng, "A bidirectional high-frequency-link single-phase inverter: modulation, modeling, and control," *IEEE Trans. Power Electron.*, vol. 29, no. 8, pp. 4049-4057, 2014.
- [13] Y.-Y. Tzou, S.-L. Jung, and H.-C. Yeh, "Adaptive repetitive control of PWM inverters for very low THD AC-voltage regulation with unknown loads," *IEEE Trans. Power Electron.*, vol. 14, no. 5, pp. 973-981, Sept. 1999.
- [14] D. Chen, J. Zhang, and Z. Qian, "an improved repetitive control scheme for grid-connected inverter with frequency-adaptive capability," *IEEE Trans. Ind. Electron.*, vol. 60, no. 2, pp. 814-823, Feb. 2013.
- [15] K. Zhou, Y. Yang, F. Blaabjerg, and D. Wang, "Optimal selective harmonic control for power harmonics mitigation," *IEEE Trans. Ind. Electron.*, vol. 62, no. 2, pp. 1220-1230, 2015.
- [16] M.A. Herran, J.R. Fischer, S.A. Gonzalez, M.G. Judewicz, I. Carugati, and D.O. Carrica, "Repetitive control with adaptive sampling frequency for wind power generation systems," *IEEE J. Emerg. Sel. Topics Power Electron.*, vol. 2, no. 1, pp. 58-69, Mar. 2014.
- [17] Z. Cao and G.F. Ledwich, "Adaptive repetitive control to track variable periodic signals with fixed sampling rate," *IEEE/ASME Trans. Mechatron.*, vol. 7, no. 3, pp. 378-384, Sept. 2002.
- [18] B. Zhang, D. Wang, K. Zhou, and Y. Wang, "Linear phase lead compensation repetitive control of a CVCF PWM inverter," *IEEE Trans. Ind. Electron.*, vol. 55, no. 4, pp. 1595-1602, 2008.
- [19] B. Zhang, K. Zhou, Y. Wang, and D. Wang, "Performance improvement of repetitive controlled PWM inverters: A phase-lead compensation solution," *International Journal of Circuit Theory and Applications*, vol. 38, no. 5, pp. 453-469, 2010.
- [20] B. Zhang, K. Zhou, Y. Ye, and D. Wang, "Design of linear phase lead repetitive control for CVCF PWM DC-AC converters," in *Proc. of ACC*, pp. 1154-1159, 2005.
- [21] G.A. Ramos and R. Costa-Castelló, "Power factor correction and harmonic compensation using second-order odd-harmonic repetitive control," *IET Control Theory & Applications*, vol. 6, no. 11, pp. 1633-1644, Jul. 2012.
- [22] Y.H. Yang, K. Zhou, M. Cheng, and B. Zhang, "Phase compensation multi-resonant control of CVCF PWM converters," *IEEE Trans. Power Electron.*, vol. 28, no. 8, pp. 3923-3930, 2013.
- [23] Y. Wang, D. Wang, B. Zhang, and K. Zhou, "Fractional delay based repetitive control with application to PWM DC/AC converters," in *Proc. IEEE ICCA*, pp. 928-933, 2007.
- [24] Y. Yang, K. Zhou, H. Wang, F. Blaabjerg, D. Wang, and B. Zhang, "Frequency adaptive selective harmonic control for grid-connected inverters," *IEEE Trans. Power Electron.*, vol. 30, no. 7, pp. 3912-3924, 2015.
- [25] Z. Zou, K. Zhou, Z. Wang, and M. Cheng, "Frequency adaptive fractional order repetitive control of shunt active power filters," *IEEE Trans. Ind. Electron.*, vol. 62, no. 3, pp. 1659 - 1668, 2015.
- [26] Z. Zou, K. Zhou, Z. Wang, and M. Cheng, "Fractional-order repetitive control of programmable AC power sources," *IET Power Electron.*, vol. 7, no. 2, pp. 431-438, Feb. 2014.
- [27] D. Chen, J. Zhang, and Z. Qian, "An improved repetitive control scheme for grid-connected inverter with frequency-adaptive capability," *IEEE Trans. Ind. Electron.*, vol. 60, no. 2, pp. 814-823, Feb. 2013.
- [28] M. Rashed, C. Klumpner, and G. Asher, "Repetitive and resonant control for a single-phase grid-connected hybrid cascaded multilevel converter," *IEEE Trans. Power Electron.*, vol. 28, no. 5, pp. 2224-2234, May 2013.
- [29] M. Ciobotaru, R. Teodorescu, and F. Blaabjerg, "A new single-phase PLL structure based on second order generalized integrator," in *Proc. of PESC*, pp. 1-6, 18-22 June 2006.