

Aalborg Universitet



AALBORG
UNIVERSITY

Cross-Circulating Current Suppression Method for Parallel Three-Phase Two-Level Inverters

Wei, Baoze; Guerrero, Josep M.; Guo, Xiaoqiang

Published in:

Proceedings of the 5th IEEE International Conference on Consumer Electronics (IEEE ICCE-Berlin 2015)

DOI (link to publication from Publisher):

[10.1109/ICCE-Berlin.2015.7391297](https://doi.org/10.1109/ICCE-Berlin.2015.7391297)

Publication date:

2015

Document Version

Early version, also known as pre-print

[Link to publication from Aalborg University](#)

Citation for published version (APA):

Wei, B., Guerrero, J. M., & Guo, X. (2015). Cross-Circulating Current Suppression Method for Parallel Three-Phase Two-Level Inverters. In *Proceedings of the 5th IEEE International Conference on Consumer Electronics (IEEE ICCE-Berlin 2015)* (pp. 423-427). IEEE Press. <https://doi.org/10.1109/ICCE-Berlin.2015.7391297>

General rights

Copyright and moral rights for the publications made accessible in the public portal are retained by the authors and/or other copyright owners and it is a condition of accessing publications that users recognise and abide by the legal requirements associated with these rights.

- Users may download and print one copy of any publication from the public portal for the purpose of private study or research.
- You may not further distribute the material or use it for any profit-making activity or commercial gain
- You may freely distribute the URL identifying the publication in the public portal -

Take down policy

If you believe that this document breaches copyright please contact us at vbn@aub.aau.dk providing details, and we will remove access to the work immediately and investigate your claim.

Cross-Circulating Current Suppression Method for Parallel Three-Phase Two-Level Inverters

Baoze Wei, Josep M. Guerrero
 Department of Energy Technology
 Aalborg University
 Aalborg, Denmark
 bao@et.aau.dk, joz@et.aau.dk

Xiaoqiang Guo
 Department of Electrical Engineering
 Yanshan University
 Qinhuangdao, China
 gxq@ysu.edu.cn

Abstract—The parallel architecture is very popular for power inverters to increase the power level. This paper presents a method for the parallel operation of inverters in an ac-distributed system, to suppress the cross-circulating current based on virtual impedance without current-sharing bus and communication bus. Simulation and experimental results verify the effectiveness of the control method.

Index Terms—Parallel, distributed, virtual impedance, circulating current, current-sharing.

I. INTRODUCTION

Renewable or nonconventional energy resources, such as photovoltaic arrays, fuel cells, or small wind turbines can be connected to a common AC line to supply the distributed loads working as a microgrid. The diagram of a microgrid is shown in Fig.1. And the microgrids are requiring new control strategies and power architectures to deal with high power demand. Increasing the system's capacity by connecting inverters in parallel is a well-known solution [1-5]. But a circulating current problem must be considered in parallel inverters system because of the different parameters of the parallel inverters [6-7]. The existence of the circulating current can increase the power loss of the system, cause distortion of the output current of inverters and so on [8-9]. So measures should be taken to suppress the circulating current.

The three-phase two-level voltage source inverters (VSI) are widely used in microgrids [10]. Figure 2 shows a parallel inverters system consisting a number of n inverters in which each of the inverter has individual DC source. The DC sources can be photovoltaic arrays, fuel cells, or small wind turbines. The cross-circulating current should be considered for the inverters which have individual DC links [3, 8, 11].

In order to avoid the circulating current, traditional approach is to use a multiwinding transformer-isolated-ac side for the parallel system. However, because of additional ac line-frequency transformer, the whole system becomes bulky and it is not desirable for an efficiency perspective [12-14].

Alternative way for avoiding circulating current is to design a current-sharing bus in the system to reduce the circulating current, all the inverters current information should be known to calculate the average current as the reference current for each of the inverter. And a communication bus is always built

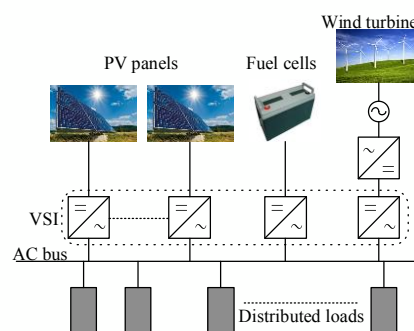

Fig.1. The diagram of a microgrid.

to exchange the information between the inverters and the control unit [14-16]. Strategies based on instantaneous current-sharing with communication bus will increase the complexity of the control system, and it is not suitable for the case of long distance between parallel inverters [17]. A well-known wireless control method is the frequency and voltage droop control [18-20]. But the performance of droop-method is sensitive to the output impedance of the inverters [7].

The output impedances of the inverters can be changed by parallel reactors to suppress the circulating current. However, they are removed in most of parallel-inverter systems because of their large volume and cost [7]. With proper control strategy, parallel reactors can be replaced by virtual impedances to suppress the circulating current because of the different parameters of inverter modules and the line impedances [7, 21-23].

Literature [6-7] shows that the circulating current depends on current sharing impedances and the difference in the output voltages of parallel inverters, while being independent of the load impedance. This paper presents a control method based on virtual impedance without current-sharing and communication bus. The virtual impedance is used to modify the output impedance of the inverters.

This paper is organized as follows: In Section II, the circulating current analysis for paralleled inverters is discussed. Then a control method based on virtual impedance is presented in Section III. In Section IV, simulation and experimental results are implemented. Both the simulation and experimental results verify the effectiveness of the presented method. The conclusions are given in Section V.

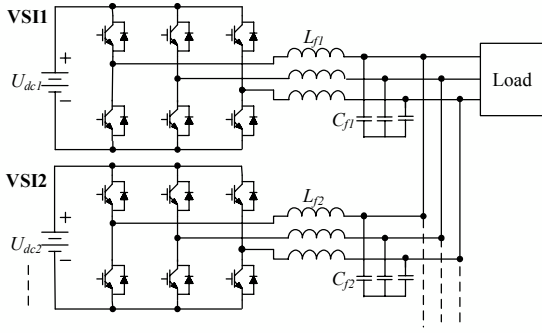

Fig. 2. Parallel three-phase two-level inverters.

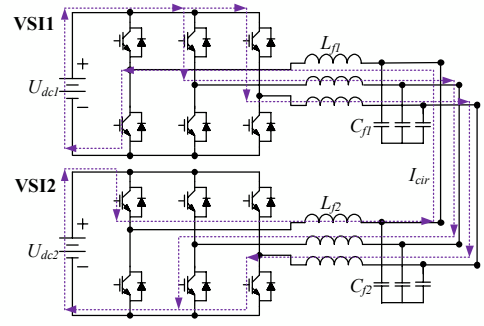

Fig. 3. The cross-circulating current path in two parallel inverters.

II. THE CROSS-CIRCULATING CURRENT ANALYSIS

This paper takes a system of two parallel-connected inverters for an example to analyze the cross-circulating current. Figure 3 shows the cross-circulating current path. The cross-circulating current will flow from one inverter to another through the common AC bus.

The parallel three-phase inverters considering the output impedances can be simplified as Fig.4 because of the similar principle of three-phase and single-phase inverters. In Fig.4, Z_1 and Z_2 are the output impedances of the two parallel inverters respectively, Z_L is the load impedance, E_1 and E_2 are the outputs voltage of the two inverters, I_1 and I_2 are the output currents, E_o is the load voltage and I_o is the load current. In a practical system, Z_1 and Z_2 will be different because of the different parameters of filters and line impedances or stray parameters. According to literature [6], the circulating current can be defined as

$$I_{cir} = \frac{I_1 - I_2}{2} \quad (1)$$

As shown in Fig.4, the following equations can be written:

$$I_1 = \frac{E_1 - E_o}{Z_1} \quad (2)$$

$$I_2 = \frac{E_2 - E_o}{Z_2} \quad (3)$$

Assuming that the output impedances of the parallel inverters are equal to each other, $Z_1 = Z_2 = Z$, then substituting (2)-(3) into (1) gives us:

$$I_{cir} = \frac{E_1 - E_2}{2Z} \quad (4)$$

Based on the former analysis, if the output voltages and the output impedances of the parallel inverters are equal to each other respectively, the circulating current can be eliminated. But in a real system, it is difficult to guarantee that different inverters have exactly the same parameters. In this case, the output impedances of the parallel inverters can be regulated by using proper virtual impedances, to offset the parameters differences of the parallel inverters and to eliminate the circulating current.

The equivalent circuit of two parallel-connected inverters with virtual impedances is shown in Fig.5. And Z_{vir1} and Z_{vir2} are the virtual impedances. Equation (5) expresses the components of the virtual impedance.

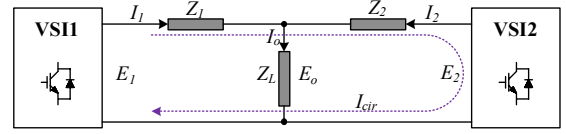

Fig.4. Equivalent circuit of two parallel inverters.

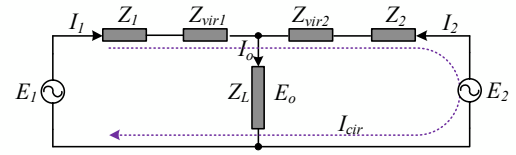

Fig. 5. Equivalent circuit of two parallel inverters with virtual impedances.

$$Z_{vir k} = R_{vir k} + j\omega L_{vir k} \quad (k = 1, 2) \quad (5)$$

The virtual impedance can be purely resistance or inductance, or combined with two of them based on the parameters differences between parallel inverters.

III. THE PRESENTED CONTROL METHOD

Figure 6 shows the block diagram of the presented control method for parallel three-phase two-level inverters. The corresponding schematic for number of n parallel inverters is shown in Fig.7. The main control loops includes the outer voltage control loop and the inner current control loop. The outer loop regulates the output voltage of the inverter with no steady-state errors. $Z_{vir k}$ ($k=1 \sim n$) is the virtual impedance to regulate the output impedances of parallel inverters that located in the filter inductor current feedback control loop. A secondary control loop is added to compensate the voltage drop on the virtual impedance.

Figure 7 shows that each of the inverters has its own control loops. It can be noticed that there is no current-sharing bus in the control loop. All the inverters in the system only use one common voltage feedback, the load voltage, it is like the voltage reference bus in literature [13], but there is no communication bus in the presented control method. G_{Ioi} , G_{Uoj} are the current controller and the voltage controller respectively, ($i=1 \sim n, j=1 \sim n$).

In practical applications, a soft start of the inverters is needed. In the presented method, when one inverter is started, the other feedbacks the load voltage from the AC bus as the reference voltage, if the open circuit output voltage synchronizes with the load voltage, this inverter will be connected to the load through a static switch.

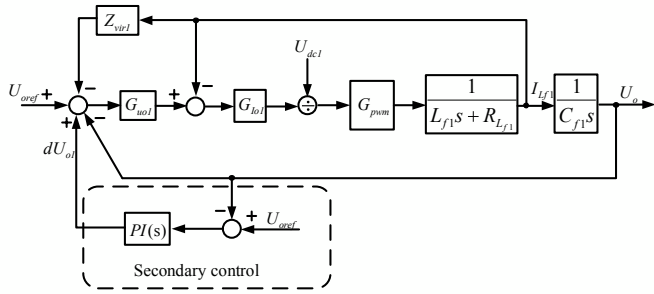

Fig. 6. Block diagram of the presented control method.

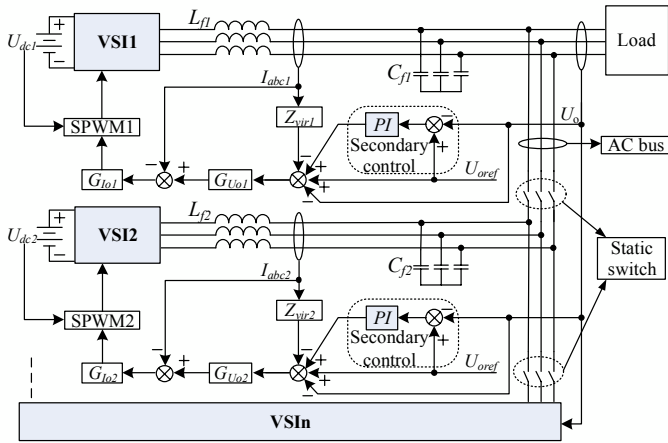

Fig. 7. The schematic of presented control method.

IV. SIMULATION AND EXPERIMENTAL RESULTS

In order to verify the effectiveness of the presented method, simulation and experiments has been done.

A. Simulation Results

A simulation model consists of two parallel-connected inverters was built in Matlab/Simulink, using the presented control method, and the parameters are listed in TABLE I. Both of the linear and nonlinear loads were considered in the simulation. The nonlinear load was a rectifier connected with a resistor (57.5Ω) and a capacitor (22μF). The maximum phase current of each inverter will be 4.85A with the linear load. The cross-circulating current can be effectively suppressed with both linear and nonlinear load as shown in Fig. 8(a) and Fig. 9(a), and the maximum value of the cross-circulating current is about 200 mA. From Fig. 8(c) and Fig. 9(b), it can be noticed that the phase currents of two inverters almost overlap each other.

B. Experimental Results

Experiments has been done on a prototype which is shown in Fig.13. It consists four three-phase two-level inverters from Danfoss and one dSPACE 1006 control unit in one cabinet. VS11 and VS12 were used in the experments to verify the effectiveness of the presented control method. Two DC suppliers from Delta were connected in series for VS11, and another DC source from GSS was used for VS12. Each inverter was connected with an L - C output filter, using the parameters listed in Table I. The experimental results under the condition

of supplying both linear and nonlinear load with the same parameters of simulation are shown below.

Figure 10 shows the results with linear load. From Fig. 10(a), it can be seen that the peak value of the cross-circulating current is about 200mA just as the simulation results in Fig. 3(a), I_{ea} , I_{eb} , I_{ec} are the differences of three phase currents of VS11 and VS12. Figure 10(b) shows single phase currents of the two inverters, the maximum value is near 4.85A as required. And the waveform of load voltage is shown in Fig. 10(c).

Experimental results by supplying a nonlinear load are shown in Fig. 11. Figure 11(a) shows the cross-circulating current, and the single phase output currents of the two inverters are shown in Fig. 11(b). It can be seen that good load-sharing capability is obtained when nonlinear loads are supplied. Figure 11(c) and (d) depicts the load current, the load voltage respectively.

The dynamic performance of the parallel system was also experimentally evaluated with respect to the case of sudden inverter connection. Initially, VS11 was working alone to supply a linear load. At time T_a , VS12 was connected to the common AC bus. Figure 12 shows the transient response of the single phase output currents of both inverters. It can be seen that the load current was almost average-sharing in two inverters.

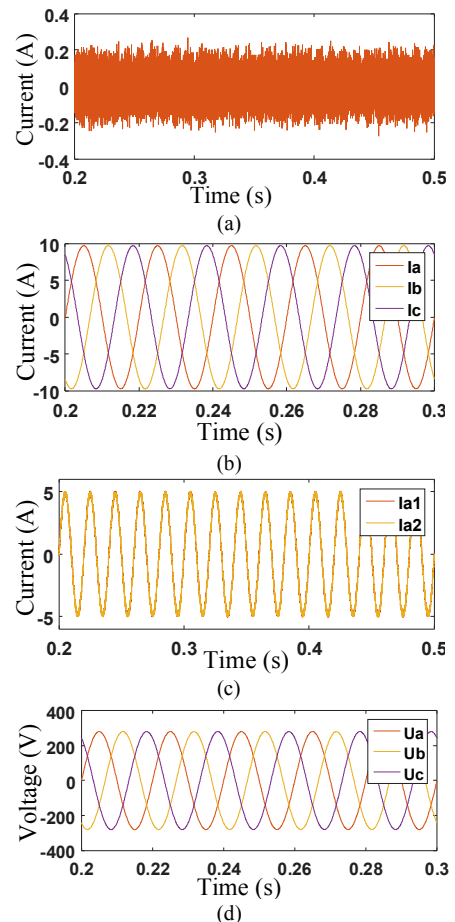

Fig. 8. Simulation results with linear load. (a) Cross-circulating current. (b) Load current. (c) Single phase current of VS11 and VS12. (d) Load voltage.

TABLE I. Simulation and experimental parameters

Parameters	Value
DC source voltage	$U_{dc1}=U_{dc2}=600V$
Linear Load	28.75Ω
Switching frequency	10kHz
Output voltage	280V
Output current	9.7A
Filtering inductances	$C_{f1}=C_{f2}=27\mu F$ (Y)
Filtering capacitances	$L_{f1}=L_{f2}=3.6mH$
Dead band of the PWM signals	$2\mu s$

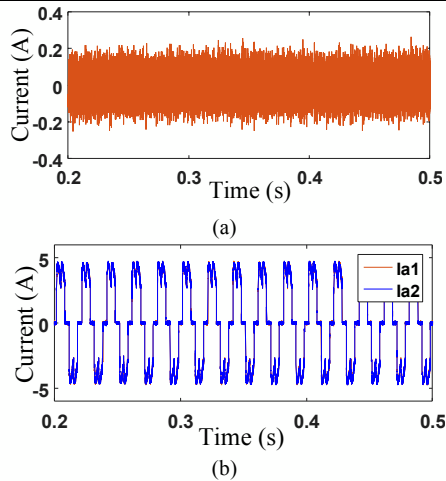

Fig. 9. Simulation results with nonlinear load. (a) Cross-circulating current. (b) Single phase current of VS11 and VS12.

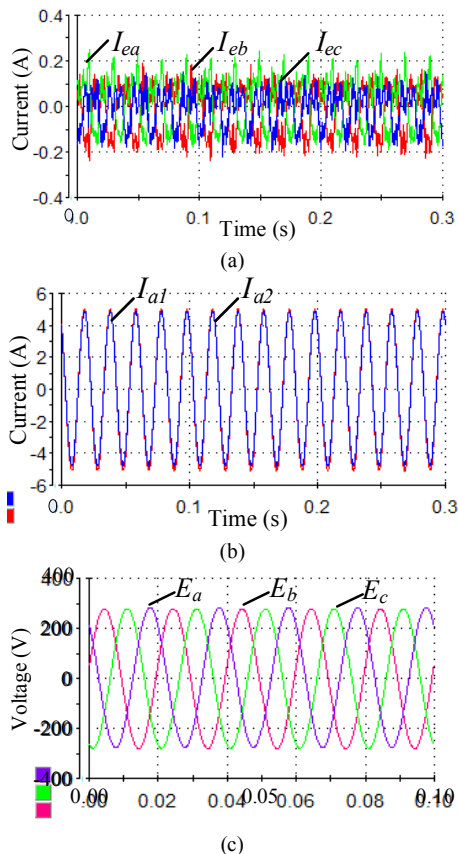

Fig. 10. Experimental results with linear load. (a) Cross-circulating current. (b) Single phase current of VS11 and VS12. (c) Load voltage.

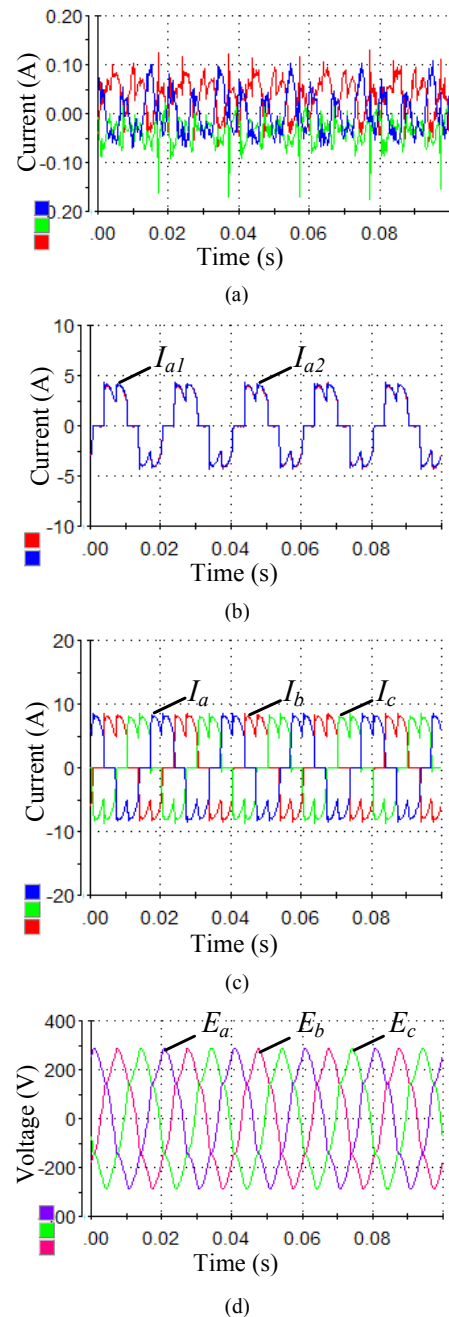

Fig. 11. Experimental results with nonlinear load. (a) Cross-circulating current. (b) Single phase current of VS11 and VS12. (c) Load current. (d) Load voltage.

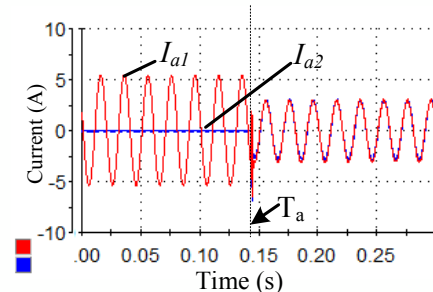

Fig. 12. Single phase current of VS11 and VS12 when VS12 suddenly connected.

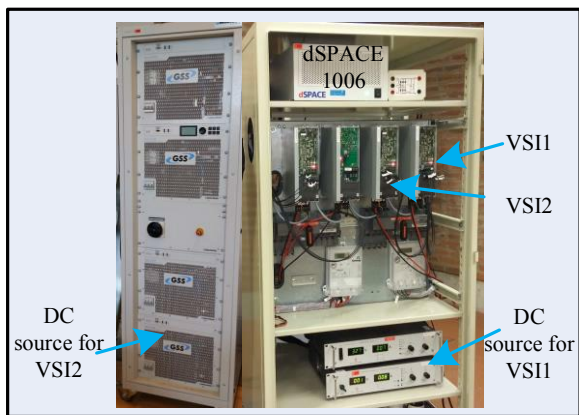

Fig.13. The experiment prototype.

V. CONCLUSION

Parallel inverters are widely used in the microgrid applications for high power demand, and the current-sharing scheme is necessary. A control method without current-sharing bus based on virtual impedance is presented in this paper. Simulation and experiments has been done when parallel-connected inverters were sharing linear or nonlinear load. The results demonstrate that, the cross-circulating current between the parallel inverters can be effectively suppressed, and the average current-sharing is realized.

REFERENCES

- [1] J. S. Siva Prasad and G. Narayanan, "Minimization of grid current distortion in parallel-connected converters through carrier interleaving," *IEEE Trans. Ind. Electron.*, vol. 61, no. 1, pp. 76–91, Jan. 2014.
- [2] D. Zhang, F. Wang, R. Burgos, and D. Boroyevich, "Common-mode circulating current control of paralleled interleaved three-phase two-level voltage-source converters with discontinuous space vector modulation," *IEEE Trans. Power Electron.*, vol. 26, no. 12, pp. 3925–3935, Dec. 2011.
- [3] H. Inaba, K. Kishine, and Y. Igura, "An electric power conversion system composed of two parallel-connected converters providing different output currents," in *Proc. 15th Int. Conf. ICEMS, 2012*, pp. 1–4.
- [4] T. B. Lazzarin, G. A. T. Bauer and I. Barbi, "A control strategy for parallel operation of single-phase voltage source inverters: analysis, design and experimental result," *IEEE Trans. Ind. Electron.*, vol. 60, no. 6, pp. 2194–2204, Jun. 2013.
- [5] M. Narimani, and G. Moschopoulos, G, "Improved method for paralleling reduced switch VSI modules: harmonic content and circulating current," *IEEE Trans. Power. Electron.*, vol. 29, no. 7, pp. 3308–3317, Sep. 2013.
- [6] H. Cai, R. Zhao, and H. Yang, "Study on Ideal Operation Status of Parallel Inverters," *IEEE Trans. Power Electron.*, vol. 23, no. 6, pp. 2964–2969, Nov. 2008.
- [7] Y. Zhang, M. Yu, F. Liu, Y. Kang, "Instantaneous Current Sharing Control Strategy for Parallel Operation of UPS Modules Using Virtual Impedance," *IEEE Trans. Power Electron.*, vol. 28, no. 1, pp. 432–440, Jan. 2013.
- [8] F. Wang, Y. Wang, Q. Gao and C. Wang, "A Control Strategy for Suppressing Circulating Currents in Parallel Connected PMSM Drives with Individual DC-links," *IEEE Trans. Power Electron.*, DOI:10.1109/TPEL.2015.2422791.
- [9] F. Xu, B. Guo, Z. Xu, L.M. Tolbert, F. Wang, and B.J. Blalock. "Paralleled Three-Phase Current-Source Rectifiers for High-Efficiency Power Supply Applications," *IEEE Trans. Industry Applications*. vol. 51, no. 3, pp. 2388–2397, May. 2015.
- [10] S. Bernet, "Recent developments of high power converters for industry and traction applications," *IEEE Trans. Power Electron.*, vol. 15, no. 6, pp. 1102–1117, Nov. 2000.
- [11] Ching-Tsai Pan, and Yi-Hung Liao, "Modeling and Coordinate Control of Circulating Currents in Parallel Three-Phase Boost Rectifiers," *IEEE Trans. Ind. Electron.*, vol. 54, no. 2, pp. 76–91, Apr. 2007.
- [12] S. Kim, M. H. Todorovic, and P. N. Enjeti, "Three-phase active harmonic rectifier (AHR) to improve utility input current THD in telecommunication power distribution system," *IEEE Trans. Ind. Appl.*, vol. 39, no. 5, pp. 1414–1421, Sep./Oct. 2003.
- [13] X. Zhang, J. Chen, Y. Ma, Y. Wang, and D. Xu, "Bandwidth Expansion Method for Circulating Current Control in Parallel Three-phase PWM Converter Connection System," *IEEE Trans. Power Electron.*, vol. 29, no. 12, pp. 6847–6856, Dec. 2014.
- [14] T. B. Lazzarin, and I. Barbi, "DSP-Based Control for Parallelism of Three-Phase Voltage Source Inverter," *IEEE Trans. Ind. Info.*, vol. 9, no. 2, pp. 749–759, May. 2013.
- [15] Y. Bae and R. Kim, "Suppression of Common-Mode Voltage Using a Multicentral Photovoltaic Inverter Topology With Synchronized PWM," *IEEE Trans. Ind. Electron.*, vol. 61, no. 9, pp. 4722–4733, Sep. 2014.
- [16] S. Shah and P. S. Sensarma, "Three degree of freedom robust voltage controller for instantaneous current sharing among voltage source inverters in parallel," *IEEE Trans. Power Electron.*, vol. 25, no. 12, pp. 3003–3014, Dec. 2010.
- [17] M. Prodanovic, T.C. Green, and H. Mansir, "A Survey of control methods for three-phase inverters in parallel connection," *IEEE Eighth International Conference on Power Electronics and Variable Speed Drives*, pp. 472–477, London, Sep. 2000.
- [18] J. Matas, M. Castilla, L. G. D. Vicuna, J. Miret, and J. C. Vasquez, "Virtual impedance loop for droop-controlled single-phase parallel inverters using a second-order general-integrator scheme," *IEEE Trans. Power Electron.*, vol. 25, no. 12, pp. 2993–3002, Dec. 2010.
- [19] W. Yao, M. Chen, J. Matas, J. M. Guerrero, and Z. Qian, "Design and analysis of the droop control method for parallel inverters considering the impact of the complex impedance on the power sharing," *IEEE Trans. Ind. Electron.*, vol. 58, no. 2, pp. 576–588, Feb. 2011.
- [20] U. Borup, F. Blaabjerg, and P. N. Enjeti, "Sharing of nonlinear load in parallel-connected three-phase converters," *IEEE Trans. Ind. Appl.*, vol. 37, no. 6, pp. 1817–1823, Nov./Dec. 2001.
- [21] J. He, Y. Li, J.M. Guerrero, F. Blaabjerg and J.C. Vasquez, "An Islanding Microgrid Power Sharing Approach Using Enhanced Virtual Impedance Control Scheme," *IEEE Trans. Power Electron.*, vol. 28, no. 11, pp. 5272–5282, Nov. 2013.
- [22] J. Matas, M. Castilla, L. G. de Vicuña, J. Miret, J. C. Vasquez, "Virtual impedance loop for droop-controlled single-phase parallel inverters using a second-order general-integrator scheme," *IEEE Trans. Power Electron.*, vol. 25, no.4, pp. 2993–3002, Dec. 2010.
- [23] J. He and Y. Li, "Analysis, design, and implementation of virtual impedance for power electronics interfaced distributed generation," *IEEE Trans. Ind. Electron.*, vol. 47, no.6, pp. 2525–2538, Nov. 2011.