



Aalborg Universitet

AALBORG UNIVERSITY
DENMARK

Harmonic currents Compensator Grid-Connected Inverter at the Microgrid

Asuhaimi Mohd Zin, A.; Naderipour, A. ; Habibuddin, M.H.; Guerrero, Josep M.

Published in:
Electronics Letters

DOI (link to publication from Publisher):
[10.1049/el.2016.1890](https://doi.org/10.1049/el.2016.1890)

Publication date:
2016

Document Version
Early version, also known as pre-print

[Link to publication from Aalborg University](#)

Citation for published version (APA):
Asuhaimi Mohd Zin, A., Naderipour, A., Habibuddin, M. H., & Guerrero, J. M. (2016). Harmonic currents Compensator Grid-Connected Inverter at the Microgrid. *Electronics Letters*, 52(20), 1714 - 1715.
<https://doi.org/10.1049/el.2016.1890>

General rights

Copyright and moral rights for the publications made accessible in the public portal are retained by the authors and/or other copyright owners and it is a condition of accessing publications that users recognise and abide by the legal requirements associated with these rights.

- Users may download and print one copy of any publication from the public portal for the purpose of private study or research.
- You may not further distribute the material or use it for any profit-making activity or commercial gain
- You may freely distribute the URL identifying the publication in the public portal -

Take down policy

If you believe that this document breaches copyright please contact us at vbn@aub.aau.dk providing details, and we will remove access to the work immediately and investigate your claim.

Harmonic currents Compensator Grid-Connected Inverter at the Microgrid

A. Asuhaimi Mohd Zin, A. Naderipour, M. H. Habibuddin
Josep M. Guerrero

The main challenge associated with the grid-connected inverter in distributed generation (DG) systems is to maintain the harmonic contents in output current below the specified values and compensates for unbalanced loads even when the grid is subject to disturbances such as harmonic distortion and unbalanced loads. To overcome these challenges, a current control strategy for a three-phase grid-connected inverter under unbalanced and nonlinear load conditions is presented. It enables grid-connected inverter by the proposed control method to inject balanced clean currents to the grid even when the local loads are unbalanced and/or nonlinear and also compensate of the harmonic currents and control the active and reactive power. The main advantage and objective of this method is to effectively compensate for the harmonic currents content of the grid current and microgrid without using any compensation devices; such as active, passive and LCL filters.

Introduction: The main problem of microgrids (MGs) when exchanged the current with grid consider as source of harmonic distortion in Grid-Connected Inverter (GCI). Conventionally, despite the fact that it is not cost-effective, for elevating power quality problems, active power filters has been used [1]. The GCI controller is able to accomplish with unbalanced current harmonics and current of utility grid. However, compensation for the power quality problem, such as current harmonics, can be achieved through appropriate control strategies. This Letter proposes a new current compensation control method for photovoltaic (PV) GCI. The proposed control strategy consists of Synchronous Reference Frame (SRF) Phase Locked Loop (PLL) [2]. The ASRF is proposed to control power injection to the grid, and also is used for harmonic current compensation between Point of Common Coupling (PCC) and the MG.

The Proposed Control Method: To enhance grid and MG currents quality, an advanced current control method for the GCI, as shown in Figure 1, is introduced.

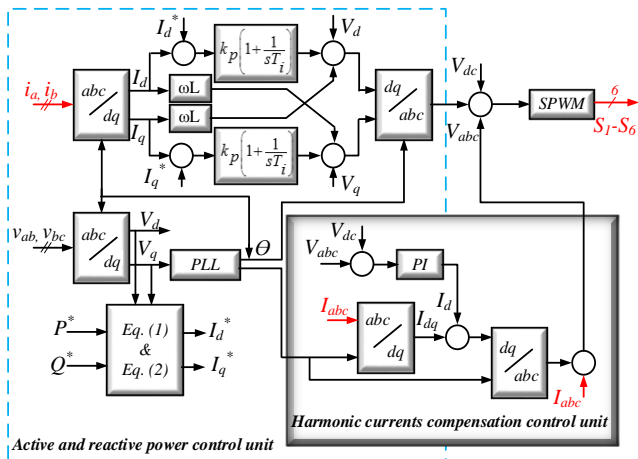

Fig. 1 Block diagram of the proposed control method

Various control methods are based on the frequency domain or the time domain. The ASRF control is also called the dq control and is used to control the grid-connected inverter in this letter. This method uses a reference frame transformation module, $abc \rightarrow dq$, to transform it into a reference frame that rotates synchronously using the transform of the grid current and the voltage waveforms. The park transformation application to three generic three-phase quantities supplies their components in $dq0$ coordinates [3]. In general, three phase voltages and currents are transformed into $dq0$ coordinates by matrix [L] as follows:

$$\begin{bmatrix} u_d \\ u_q \\ u_0 \end{bmatrix} = [L] \begin{bmatrix} u_A \\ u_B \\ u_C \end{bmatrix} \text{ and } \begin{bmatrix} i_d \\ i_q \\ i_0 \end{bmatrix} = [L] \begin{bmatrix} i_A \\ i_B \\ i_C \end{bmatrix} \quad (1)$$

$$[L] = \sqrt{\frac{2}{3}} \begin{bmatrix} \sin \alpha & \sin \left(\alpha - \frac{2\pi}{3} \right) & \sin \left(\alpha + \frac{2\pi}{3} \right) \\ \cos \alpha & \cos \left(\alpha - \frac{2\pi}{3} \right) & \cos \left(\alpha + \frac{2\pi}{3} \right) \\ \frac{1}{\sqrt{2}} & \frac{1}{\sqrt{2}} & \frac{1}{\sqrt{2}} \end{bmatrix} \quad (2)$$

The phase angle of voltage and current signals set as reference current which achieves unity power factor while $I^*_q=0$. Refer to figure 1 the current controller is under study. The Sinusoidal Pulse Width Modulation (SPWM) voltage frame guaranties. The voltage reference and design PLL synchronize inverter with grid. Hence I^*_q and I^*_d as reference current in dq transform re-calculate as:

$$P = V_d I_d + V_q I_q \xrightarrow{V_q=0} I_d^* = \frac{P}{V_d} \quad (3)$$

$$Q = V_d I_q - V_q I_d \xrightarrow{V_q=0} I_q^* = \frac{Q}{V_d} \quad (4)$$

where V_d and V_q are the grid voltage in dq transform. Furthermore the inverter is able to deliver P^* and Q^* where are reference active and reactive power, respectively. The inverter inject real power which the flow is controlled by I_d and a specified reference current I_d^* . When the system is fully inject reactive power $I_q^*=0$. The other components I_d^* is extracted of the DC capacitor's dynamics analysis. Hence the V_d and V_q of inverter gate SPWM are obtaining as following:

$$\begin{aligned} V_d^* &= K_p (I_d^* - I_d) + K_I \int (I_d^* - I_d) dt - \omega L_f I_q + V_d \\ V_q^* &= K_p (I_q^* - I_q) + K_I \int (I_q^* - I_q) dt - \omega L_f I_d + V_q \end{aligned} \quad (5)$$

The SPWM modulating voltage signals are transformed from $dq0$ to abc frame. The PI controller are the main methods to control dq due to proper regulation of DC variables. Equation (6) gives the matrix transfer function in dq coordinates:

$$G_{PI}^{(dq)}(s) = \begin{bmatrix} K_p + \frac{K_i}{s} & 0 \\ 0 & K_p + \frac{K_i}{s} \end{bmatrix} \quad (6)$$

where K_p and K_i are the controller's proportional and integral gain, respectively. In order to provide the phase information of the grid voltage, which is required to generate the current reference i_{ref} and also is designed to make the inverter synchronism with grid, The PLL technique can be used. Using a PLL system, the three current references are created, each with the error going into the controller, and the corresponding measured current can be compared. The switches of GCI are controlled by the output of PLL system. The duty cycles for the SPWM pattern is generated by modulator which is controlled by three PI units. The PLL schematic is illustrated in Figure 2.

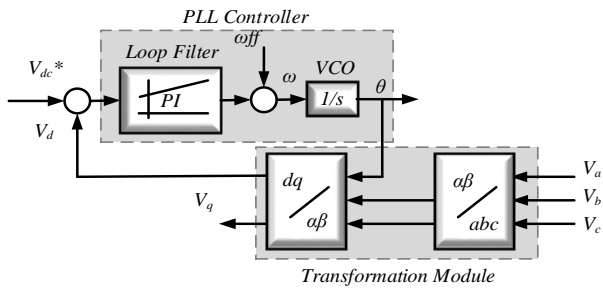

Fig. 2 PLL structure of the three-phase

The dq rotating frame converts back to abc stationary frame uses inverse Park's transformation Eq. 7, 8 and 9, by extracting reference signal.

$$i_{sa}^* = i_d^* \sin(\omega t) + \cos(\omega t) \quad (7)$$

$$i_{sb}^* = i_d^* \sin\left(\omega t - \frac{2\pi}{3}\right) + \cos\left(\omega t - \frac{2\pi}{3}\right) \quad (8)$$

$$i_{sc}^* = i_d^* \sin\left(\omega t + \frac{2\pi}{3}\right) + \cos\left(\omega t + \frac{2\pi}{3}\right) \quad (9)$$

The unit of control compensation of harmonic currents uses DC quantities. The design compensation current is injected by appropriate gate plus for inverter which is transferred by gate driver controller to extract reference signal.

Simulation results: The basic MG in this letter includes the MT, the fuel cell, wind turbine and PV array which are connected to the grid by the interface inverter. The proposed control methods is applied to the PV. Furthermore, a fuel cell has an output of 50 kW and a grid-connected PV array has an output of 100 kW and also a 9 MW wind farm and 25MW MT are connected to the grid by AC/DA/AC converter. Another side of this system consists of two non-linear loads, which produced the distorted waveform. In the grid and MG the voltage is assumed sinusoidal. In the simulation, two case study are taken into account.

A. Case study I

The resulting system waveforms consist of grid, PV currents are shown in Figure 3 without any compensation devices.

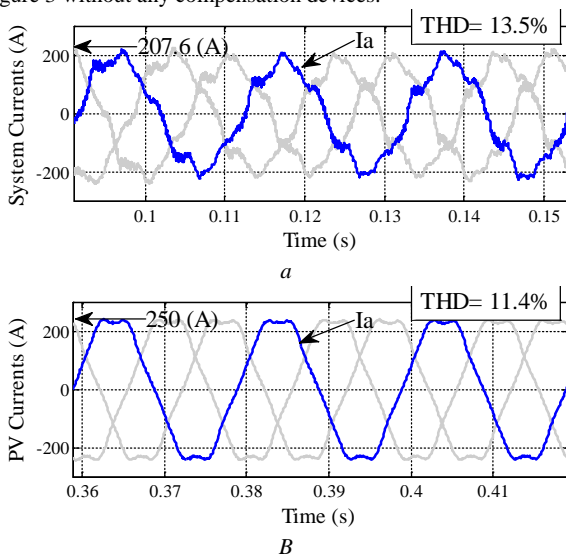

Fig. 3 System, DG units current waveforms without any compensation: (a) System currents; (b) PV currents

B. Case study II

This case study has an improved power quality with the absence of compensation devices such as passive, active and LCL filters in the MG. Figures 4 (a) and (b) show the effective compensation values of the harmonic current for the grid and the PV. When all of the loads and DGs are connected, the Total Harmonic Distortion (THD) current without any compensation was 13.5%. As shown in Figure 4 (a), THD is reduced to 1.69% in the system with the proposed control method. The Current and THD value of study system is given in Tables 1.

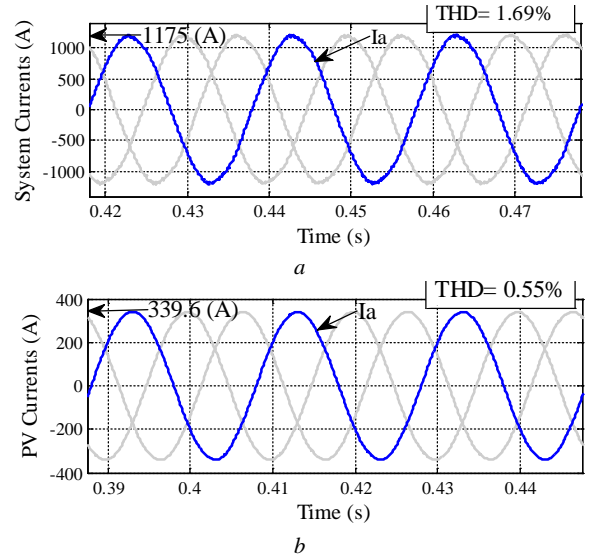

Fig. 4 System and DG unit current waveforms with propose control method; (a) System currents; (b) PV currents

Table 1: Current and THD Result

	Before Compensation		After Propose Control Method	
	Current (A)	THD %	Current (A)	THD %
System	207.6	13.55	1175	1.69
PV	250	11.43	339.6	0.55

Conclusion: This Letter proposes a new control strategy for harmonic current compensation for photovoltaic inverter between PCC and MG and also is responsible for controlling the power injection to the grid, and compensating unbalanced load. The presented simulation results show that the PCC harmonic currents due to unbalanced load, NLL and DGs are compensated to the desired value. This strategy can be used for single-phase and three-phase systems.

Acknowledgments: This work supported by Malaysian Ministry of Education (MOE) under vote 10H58.

A. Asuhaimi Mohd Zin, A. Naderipour, M. H. Habibuddin (*Faculty of Electrical Engineering, Universiti Teknologi Malaysia, Johor, Malaysia*)
E-mail: asuhaimi@utm.my
Josep M. Guerrero (*Department of Energy Technology, Aalborg University, DK-9220 Aalborg East, Denmark*)

References

- Chen, Z., Blaabjerg, F., Pedersen, JK.; 'Hybrid compensation arrangement in dispersed generation systems', *Power Deliv IEEE Trans. IEEE*, 2005, **20**, (2), pp. 1719–27
- Panda, SK., Chitti Babu, B.; 'Improved phase detection technique for grid synchronization of DG systems during grid abnormalities', In: *Engineering and Systems (SCES), 2013 Students Conference on. IEEE*, 2013, pp. 1–6
- Hui, P., Zi-ping, L., Ling, L., Chun-ming, P.; 'Hybrid compensation for harmonic, reactive power and unbalance under dq0 coordinates', In: *Electrical Machines and Systems, ICEMS 2008 International Conference on. IEEE*, 2008, pp. 2004–7.