



Aalborg Universitet

AALBORG UNIVERSITY
DENMARK

Frequency-Division Power Sharing and Hierarchical Control Design for DC Shipboard Microgrids with Hybrid Energy Storage Systems

Jin, Zheming; Meng, Lexuan; Quintero, Juan Carlos Vasquez; Guerrero, Josep M.

Published in:

Proceedings of 2017 IEEE Applied Power Electronics Conference and Exposition (APEC)

DOI (link to publication from Publisher):

[10.1109/APEC.2017.7931224](https://doi.org/10.1109/APEC.2017.7931224)

Publication date:

2017

Document Version

Early version, also known as pre-print

[Link to publication from Aalborg University](#)

Citation for published version (APA):

Jin, Z., Meng, L., Quintero, J. C. V., & Guerrero, J. M. (2017). Frequency-Division Power Sharing and Hierarchical Control Design for DC Shipboard Microgrids with Hybrid Energy Storage Systems. In *Proceedings of 2017 IEEE Applied Power Electronics Conference and Exposition (APEC)* [1594] IEEE Press. <https://doi.org/10.1109/APEC.2017.7931224>

General rights

Copyright and moral rights for the publications made accessible in the public portal are retained by the authors and/or other copyright owners and it is a condition of accessing publications that users recognise and abide by the legal requirements associated with these rights.

- Users may download and print one copy of any publication from the public portal for the purpose of private study or research.
- You may not further distribute the material or use it for any profit-making activity or commercial gain
- You may freely distribute the URL identifying the publication in the public portal -

Take down policy

If you believe that this document breaches copyright please contact us at vbn@aub.aau.dk providing details, and we will remove access to the work immediately and investigate your claim.

Frequency-Division Power Sharing and Hierarchical Control Design for DC Shipboard Microgrids with Hybrid Energy Storage Systems

Zheming Jin, Lexuan Meng, Juan C. Vasquez, Josep M. Guerrero

Department of Energy Technology
Aalborg University
Aalborg, Denmark

zhe@et.aau.dk, lme@et.aau.dk, juq@et.aau.dk, joz@et.aau.dk

Abstract— Due to the increasing need to reduce the cost and emission of ships, shipboard applications are calling advanced technologies to go onboard. Recently, cleaner power sources (i.e. gas turbines, fuel cell, solar and wind power), energy storage, advanced control and power/energy management are introduced to meet the new requirement, and therefore, making shipboard power system more like a microgrid. In this paper, a frequency-division based power sharing method is proposed to solve the contradiction between fuel efficiency and dynamic load conditions of marine vessels. With effective design, the operation point of prime movers can be maintained at their optimal area, meanwhile, different energy storages will provide characteristic based response. On the basis of the proposed power sharing method, voltage restoration and power management-level control methods are also introduced to form hierarchical control design. A study case is modeled and HIL simulations are carried out to verify the proposed control strategies.

Keywords—Shipboard power system, microgrid, coordinated control, hybrid energy storage system, hierarchical control.

I. INTRODUCTION

Driven by both environmental and economic concerns, fuel efficiency and emission problem have drawn great attention in recent years. Currently, more and more emerging technologies are being introduced in marine vessels to enhance performance. Electric propulsion is increasingly being used in modern more-electric ships and future all-electric ships [1-3]. At the same time, sustainable energy sources, such as solar, wind and fuel cells (FCs), have been installed and tested in several prototypes [4-6]. On the other hand, the significant fuel saving effect of energy storage system (ESS) has been proven in the field of land vehicles. Several diesel-electric hybrid propulsion systems with both series and parallel configurations have been tested by prototype vessels [7-9]. In addition to the fuel saving effect, ESSs can also contribute to the reliability and survivability of such a physically isolated power system, thus being recognized to be promising in future marine vessels [10-14]. Besides that, DC distribution, especially in medium voltage DC (MVDC) level, has drawn great attention from civilian and naval vessels for its better efficiency and compatibility to support these emerging power sources and electric propulsion. In this

context, the future shipboard power systems are expected to include not only gensets (either diesel engine or turbine powered) but also other power sources of different characteristics. Therefore, shipboard power systems can be naturally identified as islanded microgrids (MGs) or shipboard MGs due to their inherent isolation and necessity to maintain autonomous operation.

When comparing terrestrial and shipboard MGs, they share some resemblance. On the one hand, the renewables have a large share in terrestrial MGs, thus bringing intermittencies to power generation while the typical loads show much slower changes. It requires compensation of intermittency to ensure stability. On the other hand, diesel or gas turbine powered gensets are still dominating shipboard MGs, whose fuel efficiency degrades significantly in dynamic or light load conditions. It requires bidirectional power support to improve efficiency. Therefore, the control and management of ESSs are playing a vital role in these two applications [10-16]. However, the high requirement on both power and energy densities of marine applications is either hard or costly to meet by single type ESSs. For this reason, hybrid energy storage system (HESS) that combines energy-intensive and power-intensive storages (i.e. battery and supercapacitor) is being considered. Although HESS can promise complementary advantages, it will inevitably increase the complexity of control and management. It can be even less effective when taking the fast transient of electric propulsion and communication delay into account.

To solve the aforementioned problem, a frequency-division based power sharing method is proposed for DC shipboard MGs in this paper. Cooperative asymmetrical droop based method is used to allow gensets work in their most efficient operational points. With an effective frequency-division design, the low-frequency and high-frequency power fluctuations can be absorbed by batteries and supercapacitors, respectively. In this way characteristic based power sharing can be achieved in a decentralized way. On the basis of proposed frequency-division based power sharing method, control methods to achieve power management and nominal voltage restoration levels are also proposed to form a comprehensive hierarchical control design, and therefore, providing an overall

solution to the systemic regulation and power management problems in the field of DC shipboard MGs.

II. POWER ARCHITECTURE AND EXISTING CONTROL METHODS IN DC SHIPBOARD MICROGRIDS

Recommended by IEEE Standard 1709-2010 [4], a study case of future DC shipboard MG shall be composed by gensets, onboard ESSs, FCs and/or renewables and onboard electrical loads. At the same time, the recent rules of the classification societies (DNV GL, ABS and CCS) will require the ship to be able to maintain operation even if one major part fails. It means the entire power system shall contain at least two sub-systems and these sub-systems must be able to connect with each other. As a solution, zonal electrical distribution system (ZEDS) is proposed [17-18]. Fig. 1(a) illustrates a typical ring-bus architecture based DC ZEDS. In this architecture, the service loads are organized to make zonal load centers, which has access to both port-side and starboard sub-systems. A sub-system is shown in Fig. 1(b), which is also the main study case of this paper.

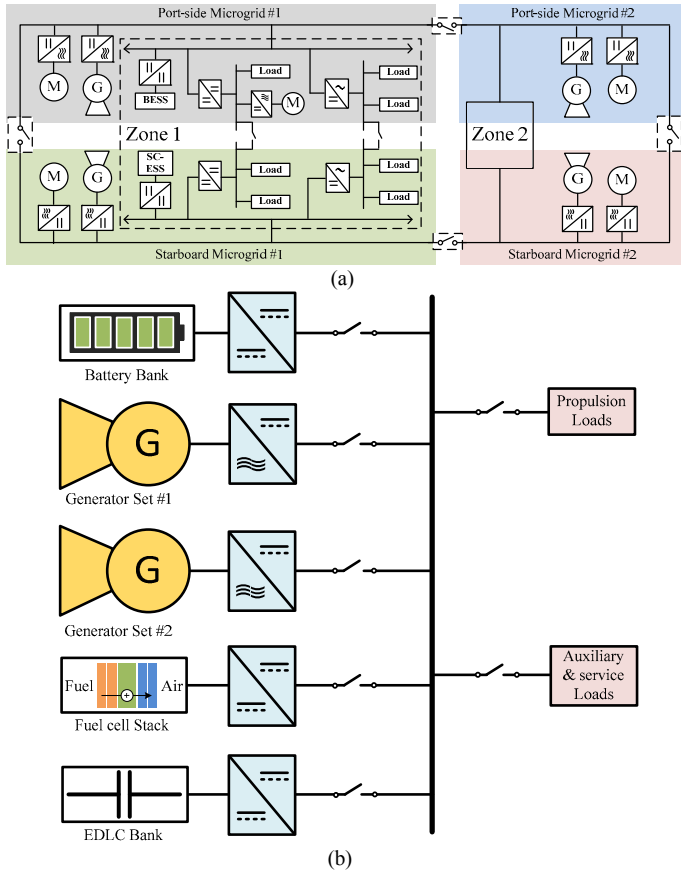

Fig. 1. Power architecture of a DC shipboard MG: (a) typical ring-bus based DC ZEDS; (b) a simplified sub-system.

A. Mechanical Part

For decades, genset that composed by generator and prime mover is the major power sources in the marine applications. In general cases, marine diesel engine or gas turbine is commonly used as prime mover, whereas well-proven three-phase wound-rotor synchronous generators (SGs) are used as generator.

Although DC distribution introduces decoupling behavior to the prime mover's rotational speed, the mechanical dynamic response will still have direct impact on the electrical power output, especially in the case of using excitation based control. Moreover, the fuel efficiency, which is the main objective of optimization functions, has to be calculated with mechanical load conditions and rotational speed. In this context, it will be necessary to integrate a mechanical model in this study.

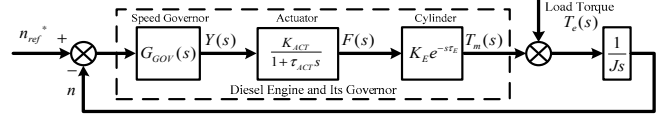

Fig. 2. Block diagram of diesel engine and its governor.

$$\tau_{ACT} = \frac{0.9}{2\pi n} \quad \tau_E = \frac{1}{2n} \quad (1)$$

$$T_e = 3n_p \left(\frac{\psi_s \psi_f}{L_{ds}} \sin \delta - \psi_s^2 \frac{L_{ds} - L_{qs}}{2L_{ds}L_{qs}} \sin 2\delta \right) \quad (2)$$

There are several different dynamic models can be derived depending on the application of diesel engine. In this paper, the delay based model is used to model the diesel engine, meanwhile, the actuator is modeled as inertia link. Fig. 2 shows the block diagram of the mechanical part of the diesel generator set, where T_m is the mechanical torque, K_{ACT} is the actuator constant, K_E is the engine torque variable. The time delays are calculated by (1) [19], where n is the rotating speed of the coaxial structure.

The load torque of the mechanical part is a sum of the electromagnetic torque of SG and frictional resistance. In this paper, the friction is not taken into consideration. For SGs, the electromagnetic torque can be calculated by (2) [20], where n_p is number of pole pairs; ψ_s is the stator flux linkage; ψ_f is the flux linkage established by either exciter or permanent magnets; δ is the power angle; L_{ds} and L_{qs} are the inductances of d-axis and q-axis, respectively.

B. Electrical Part

1) Fuel cells and renewables:

The FCs and renewables are considered as alternative to the gensets in the future marine vessels. As power source, FCs and renewables are sharing the common maximum power point characteristic, which gives a clear limitation on the maximum output. For this reason, maximum power point tracking (MPPT) based current-mode control is necessary to be used. In this paper, a current controlled FC is integrated to stands for these power sources.

2) Energy storage systems:

The integration of ESSs in marine vessels is firstly driven by the naval intention to support advanced electromagnetic launcher and weapons. In recent years, the emission control requirement make ESS increasingly considered to be installed in civilian vessels, especially in cruises, ferries, yachts, drilling and supporting vessels. Currently, batteries have the largest

share in marine applications, whereas supercapacitors are also frequently used. In this paper, a lithium titanate battery bank and a supercapacitor bank are used as a HESS. Both of them are interfaced by bidirectional Buck-Boost converters.

3) Electrical loads:

The electrical loads aboard a vessel formulate a complex cluster that contains both electric propulsion systems and ship service loads. The propulsion power accounts a large proportion of the total power consumption, and it depends on the speed and sailing resistance. In addition, the unique dynamic positioning (DP) operation of marine vessels can lead to highly dynamic propulsion loads. In this study, a programmable load is used to emulate the characteristic of shipboard electrical loads.

C. Existing Control Methods

1) Excitation control:

At present stage, the most frequently used control strategy of a DC shipboard power system is the excitation control scheme, as shown in Fig. 3. In each genset, a prime mover is coupled to a wound-rotor SG. The rotational speed will be regulated by the mechanical governors, at the same time, the DC bus voltage will be maintained by adjusting the excitation current for each SG [21].

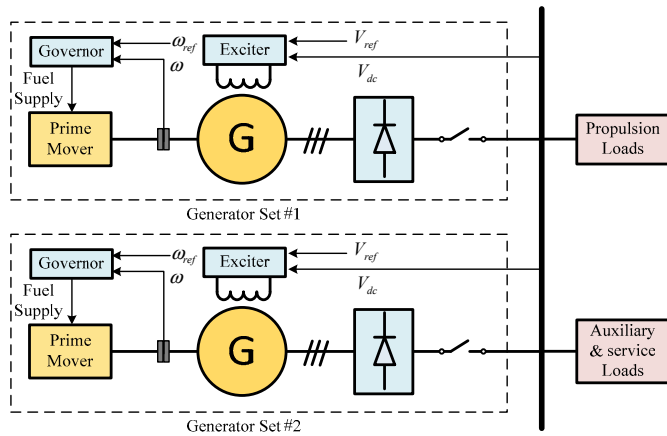

Fig. 3. Illustration of excitation control scheme.

Although this control scheme is easy to be implemented, however, the measurement error in practical works can lead to overload or instability issues. Thus, power line communication or other coordination method will be mandatory. In addition to that, the slow dynamic response of excitation control is also a big problem, especially during fast transients. For these reasons, more advanced control method is being introduced.

2) Droop control:

Droop control is firstly introduced to this field in [22], in which virtual resistance (VR) based $V-I$ droop method is used to coordinate the output of the active rectifiers of generators with different rated power. In [23], exciter based droop control is also reported as the power sharing control method. In addition, with reasonable design, the ESSs can be included as major participant of droop control, as shown in Fig. 4.

Although, droop control provides a more reliable and stable decentralized coordination method, several noteworthy points

are still problems, since it is not originally designed for diesel-dominated systems, such as:

- The droop characteristic is based on steady-state equations, the difference dynamic response is not taken into account;
- The load fluctuations are also proportionally shared.
- The efficiency issue is not considered, therefore, fuel efficiency degradation will happen.

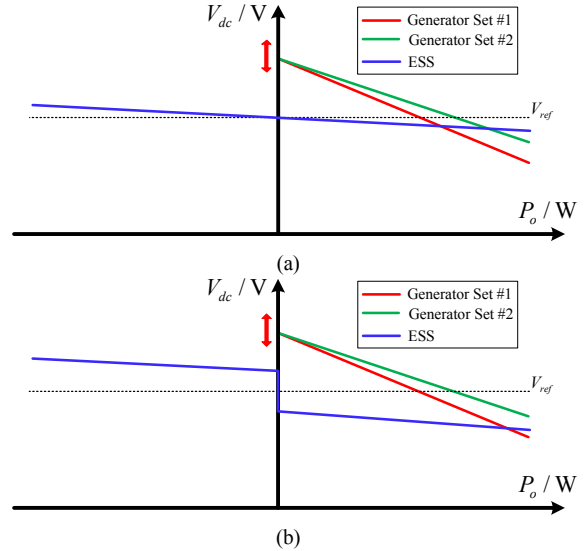

Fig. 4. Illustration of droop control in SPS: (a) continuous approach; (b) discontinuous approach.

III. PROPOSED FREQUENCY-DIVISION POWER SHARING

To solve the aforementioned problems, characteristic based power sharing method for different kinds of power sources will be a solution. In this paper, a frequency-division power sharing method is proposed. A two-step frequency subdivision method is used. In the first subdivision, inverse-droop method is proposed to divide the power flow into baseline power and power fluctuation. In the second subdivision, the power fluctuation is further divided into high-frequency and low-frequency parts, thus absorbed by different parts of the system.

A. Principle of Inverse-droop based Control

As shown in Fig. 4(a), the control effect of droop method can be expressed as:

$$V_{dc} = V_{ref}^* - R_{vri} I_{oi} \quad (3)$$

where R_{vri} is the VR of the i th converter, I_{oi} is the output current of the i th converter, V_{ref}^* is the voltage reference, V_{dc} is the bus voltage. In this way, the converter is emulating the behavior of Thevenin equivalent circuit, instead of voltage mode control. The equation (3) can also be linearized as:

$$V_{dc} = V_{ref}^* - m_i P_{oi} \quad m_i = R_{vri} / V_{nom} \quad \text{when } V_{dc} \approx V_{nom} \quad (4)$$

where P_{oi} is the output power of the i th converter, V_{nom} is the nominal voltage, m_i is named as droop coefficient. It is also widely used, especially in case that output current is discontinuous.

From a traditional point of view, the voltage deviation that introduced by VR is usually considering as a drawback, which seems to weakens the effectiveness of voltage regulation. However, this voltage deviation can also be used as another degree of freedom in coordinated control. For each Thevenin circuit, there will always be a Norton equivalent circuit, which can be derived from (3) and (4), as expressed in:

$$I_{oi} = \frac{1}{R_{vri}}(V_{ref}^* - V_{dc}) \quad \text{or} \quad P_{oi} = \frac{1}{m_i}(V_{ref}^* - V_{dc}) \quad (5)$$

It shows that the output current/power of droop controlled converters will be proportional to the voltage deviation, and this behavior share some characteristic of current control mode. In this case, the voltage deviation can be controlled to make decentralized coordination, which is the basic idea of inverse-droop method.

Fig. 5(a) shows the equivalent circuit of a droop controlled system. In such a system, if only one power source is changed to voltage control mode, the system will still be stable, even if there are measurement errors. In this case, the equivalent circuit is changed to Fig. 5(b). In steady state, the output power of droop controlled sources will be similar and proportional either in droop control or inverse-droop control. However, in transient state, the load fluctuation will be absorbed by voltage controlled source automatically in case of using inverse-droop, so that, the operational points of droop controlled sources will not change. ESSs are naturally suitable to be used as voltage controlled source, while gensets are qualified droop controlled sources, thus exploiting from both bidirectional characteristic of ESS and high efficiency in specific load condition of genset.

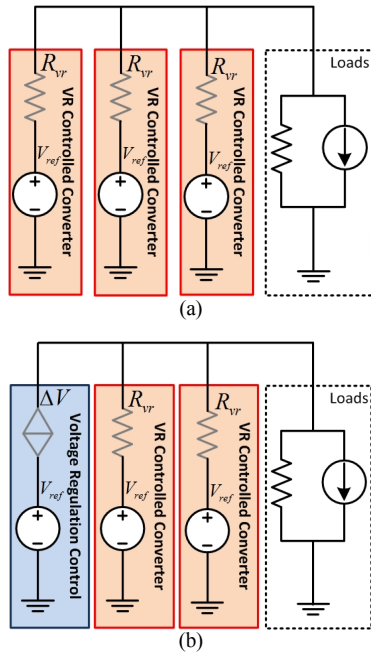

Fig. 5. Equivalent circuits of droop control and inverse-droop: (a) droop control; (b) inverse-droop control.

B. Frequency-division Control Method

With the proposed inverse-droop control method, the load power is divided into steady (zero-frequency) and dynamic parts. However, only one source can be controlled in voltage control mode, which brings a contradiction when using HESS. In addition to that, the power management is a big problem for HESS. To solve these problems, a frequency-division control method is proposed in this paper to enable using HESS and to achieve autonomous power management.

Since the initial intention of using HESS is to combine energy-intensive and power-intensive storage, and, thus taking the complementary advantage, the power sharing among different ESSs shall be different from the conventional ideas, in which not only steady-state power sharing but also transient power sharing shall be considered. Typically, power-intensive storage, such as supercapacitor or flywheel, can provide good performance in short-term high-power applications, at the same time, they are also good at dynamic or repetitive power applications with a longer lifespan. On the other hand, energy-intensive storage, usually batteries, can fulfill the requirement on high energy density. However, the stored energy in batteries can only be released with limited power range and relatively slow dynamic due to safety and lifespan concerns.

As a summary, a reasonable operation principle for HESS is to use battery for supporting long-term power flow with limited dynamic, while supercapacitor is used only to support short-term highly dynamic power during transient states. In this case, the expected power flow controller for battery shows a low-pass characteristic, while supercapacitor controller shows a high-pass characteristic, as shown in Fig. 6.

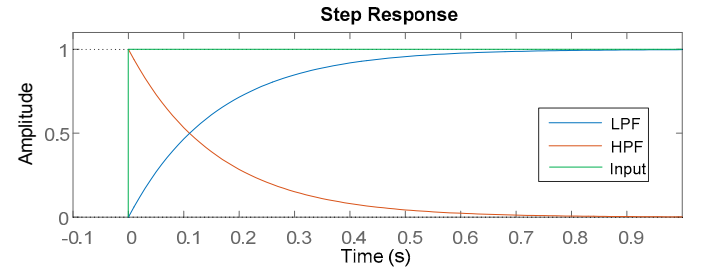

Fig. 6. The step response of paired low-pass and high-pass filter (with 1Hz cutting frequency).

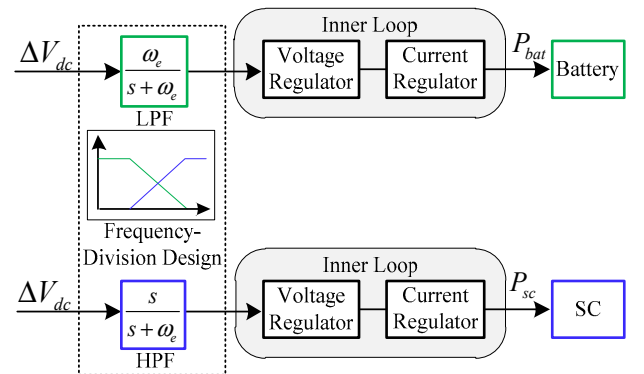

Fig. 7. The principle of frequency-division control method with inverse-droop method.

In order to subdivide the power fluctuations cooperatively, the simplest method is to insert paired low-pass filter and high-pass filter into the inner-loop controllers, thus differentiating the dynamic response of different ESSs, as shown in Fig. 7. With an effective frequency-division design, the system can spontaneously employ the complementary advantage from HESS without interventions from management level. Moreover, the stability issue can be also overcome, because the measurement error (usually static in DC system) will be filtered by high-pass filter, thus avoiding unwanted circulating currents or inaccurate power sharing.

IV. POWER MANAGEMENT AND VOLTAGE RESTORATION LEVEL CONTROL DESIGN

In terrestrial MGs, the hierarchical control architecture is becoming a standardized solution for its independent behavior between different control levels [24]. In this paper, on the basis of the inverse-droop and frequency-division control methods, the power management and voltage restoration control methods are proposed to form a hierarchical control design.

A. Power Management Level Control

In marine vessels, the fuel efficiency is the major objective to be optimized in practical operation. However, the specific fuel consumption of prime movers is typically a non-linear function to the operational points. The optimal efficiency will appear around 80% to 90% of the rated power, at a specific rotational speed, and it will reduce dramatically in the light load conditions. Therefore, the task of power management functions is to make the gensets operate at their most efficient points and manage the number of running gensets.

It differs from terrestrial low-voltage DC MGs that power level of shipboard applications is much higher, and therefore, the global stability is much more sensitive to damping effect, which is determined by VRs [25]. In this case, adjusting VR, which is the conventional control method to achieve power regulation [24], will involve complex stability problem. In this paper, the internal voltage references of source converters are adjusted instead of adjusting VR to achieve power regulation. In addition to that, power management level control is moved to the second layer of hierarchical control. In this way, as both power management level and voltage restoration level are adjusting the internal voltage references of source converters, the wider control bandwidth of the second layer will allow the control architecture to be fully decentralized.

B. Voltage Restoration Level Control

It differs from terrestrial MGs that voltage restoration level is hardly mentioned or reported in the field of marine vessels, since the grid connection is not considered during design. However, the voltage restoration will still be necessary when considering interconnection and multi-subsystem based distribution [26].

With the proposed inverse-droop control and frequency-division control methods, there is no need to introduce voltage restoration controller in each source converter. The reason is: (1) for gensets, the power management level controllers will tend to maintain a certain amount of difference between their

internal voltage reference and bus voltage, and the control bandwidth is wider than voltage restoration level; (2) the high-pass filter will filter out the low-frequency component, so that changing voltage reference with a very low control bandwidth will not affect the controller of supercapacitor. Therefore, the voltage restoration is only necessary for the converter that controls power output of battery bank.

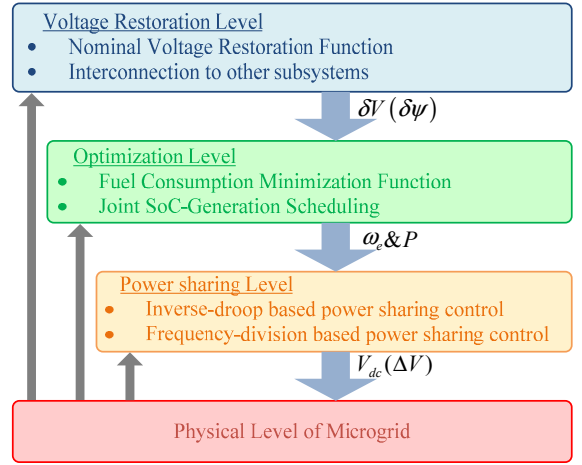

Fig. 8. Proposed hierarchical control Design.

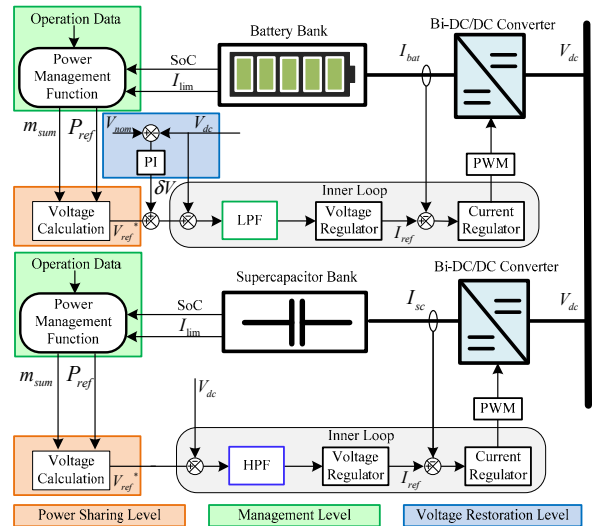

Fig. 9. ESS controllers with proposed inverse-droop and frequency-division control methods.

Ultimately, proposed hierarchical control design is as shown in Fig.8, and the implementation in controllers is as shown in Fig. 9.

V. HIL SIMULATION RESULTS

In order to validate the methods presented in this paper, a real-time simulation is conducted using Opal RT-LAB real-time simulator with the study case as shown in Fig. 1(b). The simulation model is composed by two droop controlled gensets, a battery-based ESS, a supercapacitor based ESS, a FC and a programmable load. The parameters of each component and corresponding control loops are as shown in TABLE I.

Three different simulation scenarios are carried out to verify the proposed control methods separately.

A. Scenario 1

In scenario 1, two gensets and battery-based ESS (without frequency-division control) are used to verify the proposed inverse-droop control method. The simulation result is as shown in Fig. 10. This simulation scenario can be divided into following stages:

1) *Stage 1 (0-1s)*: At this stage, the grid-forming process is emulated. The bus voltage is initialized by ESS in this stage. Meanwhile, the genset #1 accelerates from idle speed to its rated speed for supplying power in the next stage. In addition, the FC and auxiliary loads are also activated at the beginning.

2) *Stage 2 (1s-5s)*: At this stage, the propulsion load is activated and a typical load profile is performed. At $t=1s$, the power reference is set to 240kW, and it changed to 280kW at $t=2s$, which is 85% of the rated power.

3) *Stage 3 (5s-10s)*: At the start of this stage, genset #2 starts to supply power, and repeat the process of last stage.

B. Scenario 2

In scenario 2, two gensets and both ESSs are used to verify the proposed frequency-division control method. The results are as shown in Fig. 11. This simulation scenario can be divided into following stages:

TABLE I
POWER STAGE AND CONTROL PARAMETERS

Category	Parameter	Value	Unit
DC Bus	Nominal voltage (range)	1500 ($\pm 10\%$)	V
	Nominal rotational speed	1800	rpm
Gensets	Rated power	330	kW
	Rated capacity	265.2	kWh
Battery Based ESS	Maximum power (dis-/charge)	390/390	kW
	Switching frequency	1	kHz
	Inductor	4	mH
	Internal Resistance	44	m Ω
Supercapacitor Based ESS	Rated capacitance	2200	F
	Rated voltage	288	V
	Maximum capacity	91	MJ
	Switching frequency	10	kHz
FC	Inductor	2	mH
	Rated power	100	kW
Loads	Rated propulsion power	625	kW
	Auxiliary power	85	kW
Inner-loop Controllers	Battery voltage controller (P/I)	1/125	-
	Battery current controller (P/I)	0.0015/0.20	-
	SC voltage controller (P/I)	5/1000	-
	SC current controller (P/I)	0.0045/0.20	-
Power Sharing Level	Cut-off frequency of paired filters	5	Hz
	Preset voltage Reference	1640	V
	Nominal rotational speed	1800	rpm
Management Level	Droop coefficient	0.62	V/kW
	Voltage deviation controller (P/I)	0.5/5	-
Voltage Restoration Level	Voltage restoration controller (P/I)	0.1/1	-

1) *Stage 1 (0-1s)*: At this stage, the grid-forming process is emulated. The bus voltage is initialized by both ESSs in this stage. Other parts are the same with scenario 1.

2) *Stage 2 (1s-5s)*: At this stage, the propulsion load is activated with the same load profile as shown in scenario 1. At $t=1s$, the power reference is set to 240kW, and it changed to 280kW at $t=2s$, which is 85% of the rated power.

3) *Stage 3 (5s-10s)*: At the start of this stage, genset #2 starts to supply power, and repeat the process of last stage.

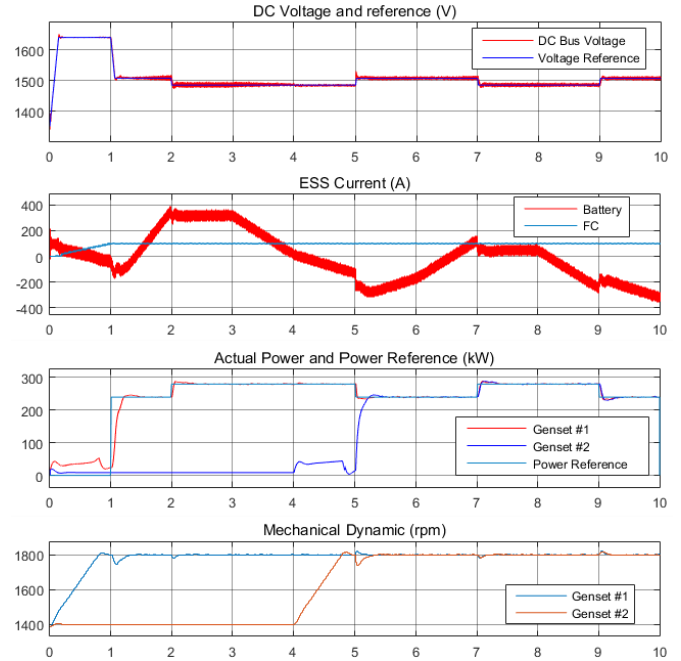

Fig. 10. Simulation results for Scenario 1.

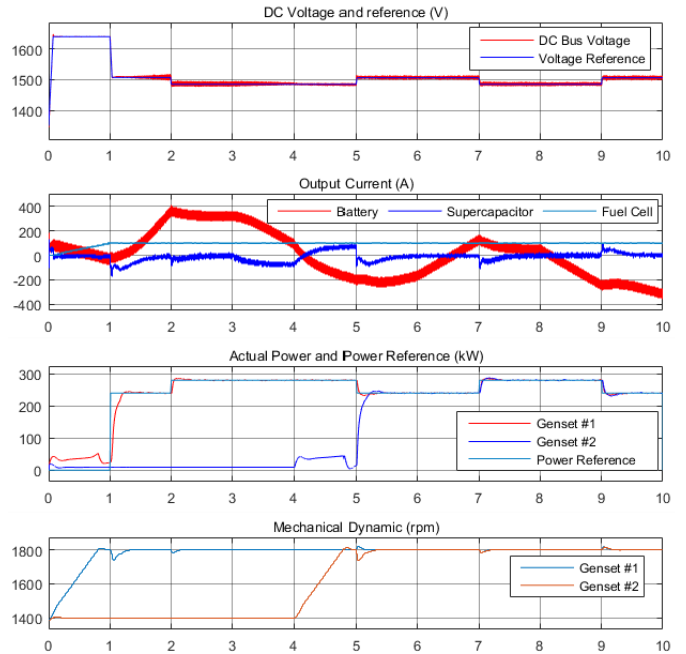

Fig. 11. Simulation results for Scenario 2.

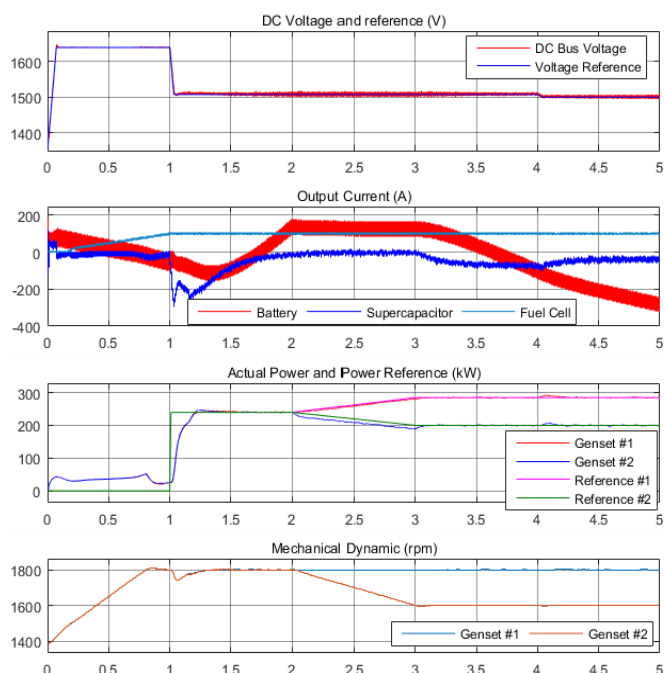

Fig. 12. Simulation results for Scenario 3.

C. Scenario 3

In scenario 3, two gensets and both ESSs are used to verify the proposed power management and voltage restoration level control methods. The results are as shown in Fig. 12. This simulation scenario can be divided into following stages:

1) *Stage 1 (0-1s)*: At this stage, the same grid-forming is performed, however, genset #1 and genset #2 accelerates this time for supplying power in the next stage.

2) *Stage 2 (1s-2s)*: At this stage, the propulsion load is activated. At $t=1s$, the centralized power reference (for calculating voltage reference) is set to 240kW.

3) *Stage 3 (2s-4s)*: At $t=2s$, the power management level is activated, the power references are changed to optimized value separately. In this case, we assume the optimal load condition for genset #1 is 285kW at 1800 rpm, as for genset #2 the value is 200 kW at 1600 rpm.

4) *Stage 4 (4s-5s)*: At $t=4s$, the voltage restoration level is activated. The DC bus voltage is restored to its nominal value.

VI. CONCLUSIONS

In this paper, a hierarchical control design for DC-SPS is presented. For the power sharing level, a novel inverse-droop method is proposed, in which the dynamic power sharing is according to the power, energy and efficiency characteristics of power sources instead of their rated power or capacity. A frequency-division method is also proposed to enable HESS in the proposed inverse-droop control method, meanwhile, the internal power management issue of HESS is also solved. The management level and voltage restoration level control methods are also proposed on the basis of inverse-droop method to provide a comprehensive solution for DC shipboard MGs. Real-time simulations are carried out with a study case to validate the proposed hierarchical control design. The real-

time simulation results verify the performance of the proposed control design under different operating conditions.

REFERENCES

- [1] J. F. Hansen and F. Wendt, "History and State of the Art in Commercial Electric Ship Propulsion, Integrated Power Systems, and Future Trends," in *Proceedings of the IEEE*, vol. 103, no. 12, pp. 2229-2242, Dec. 2015.
- [2] N. Doerry, J. Amy and C. Krolick, "History and the Status of Electric Ship Propulsion, Integrated Power Systems, and Future Trends in the U.S. Navy," in *Proceedings of the IEEE*, vol. 103, no. 12, pp. 2243-2251, Dec. 2015.
- [3] E. Skjong, E. Rødskar, M. Molinas, T. A. Johansen and J. Cunningham, "The Marine Vessel's Electrical Power System: From its Birth to Present Day," in *Proceedings of the IEEE*, vol. 103, no. 12, pp. 2410-2424, Dec. 2015.
- [4] IEEE Recommended Practice for 1 kV to 35 kV Medium-Voltage DC Power Systems on Ships," in *IEEE Std 1709-2010*, vol., no., pp.1-54, Nov. 2 2010
- [5] A. Glykas, G. Papaioannou, and S. Perissakis, "Application and cost-benefit analysis of solar hybrid power installation on merchant marine vessels," *Ocean Engineering*, vol. 37, pp. 592-602, 2010.
- [6] Jingang Han, J. F. Charpentier and Tianhao Tang, "State of the art of fuel cells for ship applications," *Industrial Electronics (ISIE), 2012 IEEE International Symposium on*, Hangzhou, 2012, pp. 1456-1461.
- [7] D. Bosisich and G. Sulligoi, "Voltage control on a refitted luxury yacht using hybrid electric propulsion and LVDC distribution," *Ecological Vehicles and Renewable Energies (EVER), 2013 8th International Conference and Exhibition on*, Monte Carlo, 2013, pp. 1-6.
- [8] T. J. McCoy, "Electric Ships Past, Present, and Future [Technology Leaders]," in *IEEE Electrification Magazine*, vol. 3, no. 2, pp. 4-11, June 2015.
- [9] T. Jaster, A. Rowe and Z. Dong, "Modeling and simulation of a hybrid electric propulsion system of a green ship," *Mechatronic and Embedded Systems and Applications (MESA), 2014 IEEE/ASME 10th International Conference on*, Senigallia, 2014, pp. 1-6
- [10] A. Monti, S. D'Arco, L. Gao and R. A. Dougal, "Energy storage management as key issue in control of power systems in future all electric ships," *Power Electronics, Electrical Drives, Automation and Motion, 2008. SPEEDAM 2008. International Symposium on*, Ischia, 2008, pp. 580-585.
- [11] R. E. Hebner *et al.*, "Dynamic Load and Storage Integration," in *Proceedings of the IEEE*, vol. 103, no. 12, pp. 2344-2354, Dec. 2015.
- [12] C. Shang, D. Srinivasan and T. Reindl, "Economic and Environmental Generation and Voyage Scheduling of All-Electric Ships," in *IEEE Transactions on Power Systems*, vol. 31, no. 5, pp. 4087-4096, Sept. 2016.
- [13] Zheming Jin, M. Savaghebi, J. C. Vasquez, Lexuan Meng and J. M. Guerrero, "Maritime DC microgrids - a combination of microgrid technologies and maritime onboard power system for future ships," *2016 IEEE 8th International Power Electronics and Motion Control Conference (IPEMC-ECCE Asia)*, Hefei, 2016, pp. 179-184.
- [14] Z. Jin, G. Sulligoi, R. Cuzner, L. Meng, J. C. Vasquez and J. M. Guerrero, "Next-Generation Shipboard DC Power System: Introduction Smart Grid and dc Microgrid Technologies into Maritime Electrical Networks," in *IEEE Electrification Magazine*, vol. 4, no. 2, pp. 45-57, June 2016.
- [15] G. K. Venayagamoorthy, R. K. Sharma, P. K. Gautam and A. Ahmadi, "Dynamic Energy Management System for a Smart Microgrid," in *IEEE Transactions on Neural Networks and Learning Systems*, vol. 27, no. 8, pp. 1643-1656, Aug. 2016.
- [16] K. Rahbar, J. Xu and R. Zhang, "Real-Time Energy Storage Management for Renewable Integration in Microgrid: An Off-Line Optimization Approach," in *IEEE Transactions on Smart Grid*, vol. 6, no. 1, pp. 124-134, Jan. 2015.
- [17] R. M. Cuzner and D. A. Esmaili, "Fault tolerant shipboard MVDC architectures," *2015 International Conference on Electrical Systems for*

Aircraft, Railway, Ship Propulsion and Road Vehicles (ESARS), Aachen, 2015, pp. 1-6.

- [18] R. Schmerda, R. Cuzner, R. Clark, D. Nowak and S. Bunzel, "Shipboard Solid-State Protection: Overview and Applications," in *IEEE Electrification Magazine*, vol. 1, no. 1, pp. 32-39, Sept. 2013.
- [19] R. Fang, W. Jiang, J. Khan and R. Dougal, "System-level thermal modeling and co-simulation with hybrid power system for future all electric ship," 2009 *IEEE Electric Ship Technologies Symposium*, Baltimore, MD, pp. 547-553. 2009,
- [20] B. K. Bose, *Modern Power Electronics and AC Drives*, 1st ed. Pearson Education. 2002. pp. 64-65
- [21] M. Aizza, D. Bosich, S. Castellan, R. Menis, G. Sulligoi and A. Tessarolo, "Coordinated speed and voltage regulation of a DC POWER generation system based on a woundfield split-phase generator supplying multiple rectifiers," *Power Electronics, Machines and Drives (PEMD 2012)*, 6th IET International Conference on, Bristol, 2012, pp. 1-6.
- [22] M. Bash, R. R. Chan, J. Crider, C. Harianto, J. Lian, J. Neely, S. D. Pekarek, S. D. Sudhoff, and N. Vaks, "A medium voltage DC testbed for ship power system research," *IEEE Electr. Sh. Technol. Symp. ESTS 2009*, pp. 560-567, 2009.
- [23] M. R. Banaei and R. Alizadeh, "Simulation-Based Modeling and Power Management of All-Electric Ships Based on Renewable Energy Generation Using Model Predictive Control Strategy," *IEEE Intell. Transp. Syst. Mag.*, vol. 8, no. 2, pp. 90-103, Jan. 2016.
- [24] J. M. Guerrero, J. C. Vasquez, J. Matas, L. G. De Vicuña, and M. Castilla, "Hierarchical control of droop-controlled AC and DC microgrids - A general approach toward standardization," *IEEE Trans. Ind. Electron.*, vol. 58, no. 1, pp. 158-172, 2011.
- [25] H. Suryanarayana and S. D. Sudhoff, "Refinements in generalized immittance based stability analysis of DC power electronics based distribution systems," *Electric Ship Technologies Symposium (ESTS), 2015 IEEE*, Alexandria, VA, 2015, pp. 80-85.
- [26] L. Meng et al., "Flexible System Integration and Advanced Hierarchical Control Architectures in the Microgrid Research Laboratory of Aalborg University," in *IEEE Transactions on Industry Applications*, vol. 52, no. 2, pp. 1736-1749, March-April 2016