

Aalborg Universitet



**AALBORG
UNIVERSITY**

Existing Sound Insulation Performance Requirements and Classification Schemes For Housing Across Europe

Rasmussen, Birgit; Machimbarrena, Maria

Published in:

COST Action TU0901 – Building acoustics throughout Europe. Volume 1: Towards a common framework in building acoustics throughout Europe

Publication date:

2014

[Link to publication from Aalborg University](#)

Citation for published version (APA):

Rasmussen, B., & Machimbarrena, M. (2014). Existing Sound Insulation Performance Requirements and Classification Schemes For Housing Across Europe. In COST Action TU0901 – Building acoustics throughout Europe. Volume 1: Towards a common framework in building acoustics throughout Europe (pp. 31-54). DiScript Preimpresion, S. L.. <http://www.costtu0901.eu/>

General rights

Copyright and moral rights for the publications made accessible in the public portal are retained by the authors and/or other copyright owners and it is a condition of accessing publications that users recognise and abide by the legal requirements associated with these rights.

- Users may download and print one copy of any publication from the public portal for the purpose of private study or research.
- You may not further distribute the material or use it for any profit-making activity or commercial gain
- You may freely distribute the URL identifying the publication in the public portal -

Take down policy

If you believe that this document breaches copyright please contact us at vbn@aub.aau.dk providing details, and we will remove access to the work immediately and investigate your claim.

2

Existing Sound Insulation Performance Requirements and Classification Schemes For Housing Across Europe*

Authors:

Birgit Rasmussen¹

María Machimbarrena²

¹ SBi, Danish Building Research Institute, Aalborg University (AAU-CPH), Copenhagen, Denmark. e-mail: bir@sbi.aau.dk

² University of Valladolid / Applied Physics Department, Architecture School, Valladolid, Spain. e-mail: maria@opt.uva.es

* Figures 2.3 and 2.4 revised October 2016

2.1. Introduction

Regulatory sound insulation requirements for dwellings exist in more than 30 countries in Europe. Classification schemes exist in several countries. In some countries, sound insulation requirements have existed since the 1950s. The first classification schemes for dwellings were implemented in the early 1990s.

Findings from comparative studies of regulatory sound insulation requirements in Europe and sound classification schemes show that sound insulation descriptors, regulatory requirements and classification schemes in Europe represent a high degree of diversity. Unfortunately, there is no sign of increasing harmonization, rather the contrary, i.e. evidence for an even more diverse situation in Europe. The studies conclude that harmonization is needed for descriptors and sound insulation classes to facilitate exchange of data and experience between countries and to reduce trade barriers. Most important is, however, that review of sound insulation requirements should be encouraged in several countries to adapt regulations to current construction trends and peoples' needs for health, wellbeing and comfort. In countries having no requirements, a change process towards decision and implementation of requirements should be initiated.

Looking into the future, harmonization of sound insulation requirements seems unrealistic. However, by preparing a harmonized European classification scheme with a number of quality classes, member states could select a "harmonized" class fitting the national needs and conditions.

This chapter will summarize the background, discuss the present situation in Europe and describe the joint efforts to reduce the diversity in Europe, thus supporting and initiating – where needed – improvement of sound insulation of new and existing dwellings in Europe to the benefit of the inhabitants and the society.

2.2. The need for sound insulation in housing

Social surveys in several European countries have shown that occupants of multi-storey housing are considerably annoyed by noise from neighbours'

activities. The World Health Organisation (WHO) defines health as “a state of complete physical, mental and social well-being and not merely the absence of disease or infirmity”, see [1]. Based on this definition, noise effects on health should not simply be understood as the adverse physical effects due to noise exposure, but also as disturbance of well-being, i.e. psychological effects of noise, which in the long term may lead to adverse physical effects. WHO has identified a considerable number of specific adverse health effects caused by environmental noise, see [2]. These effects can be medical conditions, but can also include sleep disturbance, stress etc.

The relevance of the sound insulation issue is illustrated in Figure 2.1 (ref. [3]) showing the amount of serious noise annoyance in national surveys in three EU countries, representing about 1/3 of the total EU population. In spite of uncertainties due to different methodologies (including questionnaires) applied for the surveys, the author of [3] concluded that the neighbour noise problem in Europe is significant. In [4], results from different social surveys are included, and the shortcomings due to inconsistent questionnaires in different countries are described. Neighbour noise has been addressed in a large pan-European LARES study (Large Analysis and Review of European housing and health Status) coordinated by WHO/Europe. The WHO LARES study included eight European cities, and the purpose was to evaluate the health impact of housing conditions. Results are found at the WHO website [2].

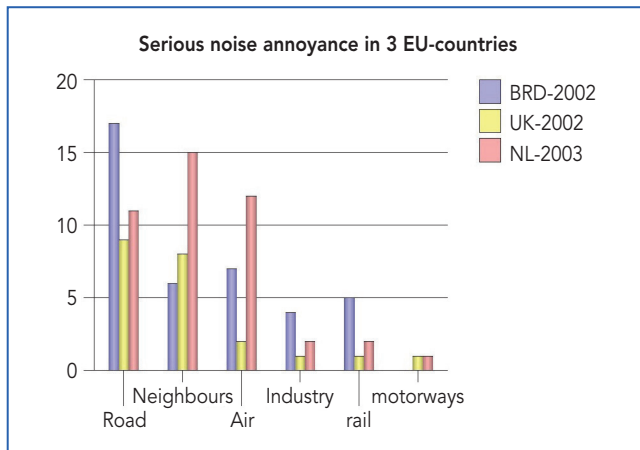

Figure 2.1. Sources of serious noise annoyance (% of inhabitants) in three EU countries. Ref: Martin van den Berg, 2004, [3].

When ranking annoyance from different noise sources, road traffic noise is the most dominant source, followed by neighbour noise. Based on statistics about populations [5] and findings from noise annoyance surveys (see eg Figure 2.1 or [4]), it seems that more than 50 million Europeans are exposed to neighbour noise causing adverse effects on quality of life. Quotes from the WHO LARES study and more detailed references are found in [6].

To keep towns and cities attractive, homes in multi-storey housing must be attractive for a variety of people and offer “quietness”. Thus, new housing must meet the needs of the people and offer comfort. Also for existing housing, sound insulation aspects should be taken into account, especially when renovating housing. The challenge is huge, and knowledge exchange between countries is highly needed.

Comparative studies of sound insulation descriptors and regulatory requirements (2008) in Europe are described in [6-7] and sound classification schemes described in [8-9]. A high degree of diversity is found for descriptors, level of requirements and classification schemes in Europe, thus impeding exchange of experience of housing design and construction details for different levels of sound insulation. The need for harmonization is emphasized in [6-7] and several research initiatives suggested.

The situation in Europe is summarized in Section 2.3 for sound insulation descriptors and in 2.4 for regulatory requirements. An overview of classification schemes is found in Section 2.5. The need for harmonization in Europe, tools for upgrading, implementation and enforcement of requirements are described in Section 2.6. The harmonization efforts and results through COST Action TU0901, [10], are described in this book. This chapter – like COST TU0901 – focuses on neighbour noise and sound insulation between dwellings.

2.3. Sound insulation descriptors in Europe

Building acoustic requirements for dwellings now exist in more than 30 countries in Europe. In some countries, national sound insulation requirements have existed since the 1950s. Sound insulation requirements are expressed by descriptors defined in standards. Within building acoustics, ISO standards are implemented as European (EN) standards and national standards.

The international descriptors for evaluation of airborne and impact sound insulation are defined in ISO 717. Table 2.1 provides a historical overview of ISO 717.

Table 2.1. Historical overview of ISO 717 standards with indication of main characteristics.

1968	ISO/R 717:1968, "Rating of sound insulation for dwellings" (first edition, 7 pages)	Field descriptors: I_a, I_i 8 dB rule
1982	ISO 717:1982, "Acoustics - Rating of sound insulation in buildings and of building elements" Part 1: Airborne sound insulation in buildings and of interior building elements Part 2: Impact sound insulation Part 3: Airborne sound insulation of facade elements and facades	Laboratory & field: Part 1: $R_w, R'_w, D_w, D_{nT,w}$ Part 2: $L_{n,w}, L'_{n,w}, L_{nT,w}$ Part 3: Several symbols No 8 dB rule, but unfavourable deviations more than 8 dB shall be reported
1996	ISO 717:1996, "Acoustics - Rating of sound insulation in buildings and of building elements" Part 1: Airborne sound insulation Part 2: Impact sound insulation	Several spectrum adaptation terms: – C, C_{tr}, C_i – Various frequency ranges 50/100-3150/5000 Hz (four ranges)
2013	ISO 717:2013, "Acoustics - Rating of sound insulation in buildings and of building elements" Part 1: Airborne sound insulation Part 2: Impact sound insulation	Same main characteristics as for 1996. Amendments about rounding rules incorporated. Allow weighting steps of 0.1 dB to be used for expressing uncertainties. References to measurement methods/equations updated.

The single-number quantities and the spectrum adaptation terms are derived from values measured according to ISO 140 [12]. The spectrum adaptation terms in ISO 717 [11] have been introduced to take into account different spectra of noise sources. Table 2.2 describes the intended use of spectrum adaptation terms according to ISO 717.

In Table 2.3 is found an overview the basic 1/3 octave ISO 717 field descriptors (single-number quantities) and the spectrum adaptation terms intended for specification and test of:

- Airborne sound insulation between dwellings
- Airborne sound insulation for facades
- Impact sound insulation between dwellings

In table 2.3, the total number of standardized descriptors is indicated for each of the above three test types. A requirement may be expressed as the sum of a single-number quantity and a spectrum adaptation term or solely as the single-number quantity. Examples of airborne and impact sound insulation requirements could be:

$$\begin{array}{ll}
 D_{nT,w} \geq 55 \text{ dB}; & L'_{nT,w} \leq 50 \text{ dB}; \\
 D_{nT,w} + C \geq 55 \text{ dB}; & L'_{nT,w} + C_l \leq 50 \text{ dB}; \\
 D_{nT,w} + C_{50-3150} \geq 55 \text{ dB}; & L'_{nT,w} + C_{l,50-2500} \leq 50 \text{ dB};
 \end{array}$$

Table 2.2. Relevant spectrum adaptation term for different types of noise sources.

Type of noise source	Relevant spectrum adaptation term
<ul style="list-style-type: none"> • Living activities (talking, music, radio, tv) • Children playing • Railway traffic at medium and high speed • Highway road traffic > 80 km/h ⁽¹⁾ • Jet aircraft short distance • Factories emitting mainly medium and high frequency noise 	C (Spectrum 1: A-weighted pink noise)
<ul style="list-style-type: none"> • Urban road traffic • Railway traffic at low speeds ⁽¹⁾ • Aircraft propeller driven • Jet aircraft large distance • Disco music • Factories emitting mainly low and medium-frequency noise 	C_{tr} (Spectrum 2: A-weighted urban traffic noise)
<ul style="list-style-type: none"> • ISO tapping machine 	C_l

Ref.: ISO 717-1:2013 and ISO 717-2: 2013. The spectra 1 and 2 are defined in ISO 717-1.

The issue of descriptors is further elaborated in [7] and [13]. For some types of buildings, e.g. for light-weight buildings, it is important to include low-frequency spectrum adaptation terms or other criteria taking into account low frequencies, see e.g. references in [6-7] and results presented in the other chapters in this book.

Table 2.3. Overview ISO 717 descriptors for evaluation of sound insulation in buildings.

ISO 717:2013 descriptors for evaluation of field sound insulation	Airborne sound insulation between rooms (ISO 717-1) ^(b)	Airborne sound insulation of facades ^(a) (ISO 717-1) ^(b)	Impact sound insulation between rooms (ISO 717-2) ^(b)
Basic descriptors (single-number quantities)	R'_w $D_{n,w}$ $D_{nT,w}$	R'_w $D_{n,w}$ $D_{nT,w}$	$L'_{n,w}$ $L'_{nT,w}$
Spectrum adaptation terms (listed according to intended main applications)	None	None	
	C $C_{50-3150}$ $C_{100-5000}$ $C_{50-5000}$	C $C_{50-3150}$ $C_{100-5000}$ $C_{50-5000}$	C_{tr} $C_{tr,50-3150}$ $C_{tr,100-5000}$ $C_{tr,50-5000}$
Total number of descriptors	3 x 5 = 15	3 x 9 = 27	2 x 3 = 6

Notes

- (a) For facades, the complete indices for R'_w , $D_{n,w}$, $D_{nT,w}$ are found in ISO 717.
 (b) For simplicity, only 1/3 octave quantities and C-terms are included in the table, although some countries allow 1/1 octave measurements for field check.

2.4. Sound insulation requirements in Europe

Comparative studies of descriptors and regulatory sound insulation requirements in Europe are described and discussed in detail in [6-7] and [13]. Results from extension to 35 countries and updates are presented in [14] and in this chapter. The comparison reveals significant differences in descriptors and requirements for dwellings. For both airborne and impact sound insulation requirements, several descriptors are applied in Europe. Table 2.4 indicates how many countries apply the different descriptors and besides, there are variants; recommendations and special rules.

The standard EN ISO 717 from 1996 has contributed to the diversity in Europe by allowing many different descriptors and by introducing spectrum adaptation terms with different extended frequency ranges, and these are maintained in the most recent version from 2013 [11], see Tables 2.1 and 2.3.

Table 2.4. Sound insulation descriptors applied for regulatory requirements in 30 countries Europe in June 2013.

Airborne sound		Impact sound	
No. of countries	Descriptor	No. of countries	Descriptor
16	R'_w	18	$L'_{n,w}$
3	$R'_w + C$	1	$L'_{n,w} + C_{1,50-2500}$
1	$R'_w + C_{50-3150}$	8	$L'_{nT,w}$
6	$D_{nT,w}$	2	$L'_{nT,w} + C_i$
2	$D_{nT,w} + C$	1	L'_w
1	$D_{nT,A} (\approx D_{nT,w} + C)$?	Variants
1	$D_{nT,w} + C_{tr}$?	Recommendations
?	Variants	?	Special rules
?	Recommendations		
?	Special rules		

The main requirements for airborne and impact sound insulation are presented in Tables 2.5 and 2.6. In order to facilitate a comparison between countries, all requirements have been converted into estimated equivalent values of $D_{nT,w}$ and $L'_{nT,w}$ based on assumptions about rooms and construction types, see Chapter 4, and the results for multi-storey housing are shown in Figures 2.2 and 2.3. The equivalent values are estimates only, as exact conversion is not possible. The results in Figures 2.2 and 2.3 show large differences between countries, especially for impact sound insulation requirements with max differences of equivalent $L'_{nT,w}$ limits more than 15 dB for multi-storey housing.

When digging deeper into the building codes and related documents, hidden special rules and/or conditions are often revealed. For example, see [15], the Swiss standard SIA 181:2006 with sound insulation requirements have become very complex to apply due to several nuisance levels and receiver sensitivity levels. Furthermore, national methods, procedures and correction terms have been defined. The symbol table is 11 pages! Another example can be special rules found in the Nordic countries, see [16-17]. Even in case of seemingly identical limits, sometimes they are different due to special rules, e.g. volume limitations.

The main findings from the comparison of regulatory airborne and impact sound insulation requirements are found in Table 2.7.

Table 2.5. Airborne sound insulation between dwellings - Main requirements in 35 European countries⁽¹⁾.

Status June 2013 ⁽¹⁾		Multi-storey housing	Row housing
Country ⁽¹⁰⁾	Descriptor ⁽²⁾	Req. [dB]	Req. [dB]
Austria	$D_{nT,w}$	≥ 55	≥ 60
Belgium	$D_{nT,w}$	≥ 54	≥ 58
Bulgaria	R'_w	≥ 53	≥ 53
Croatia	R'_w	≥ 52	≥ 52
Cyprus (8)	N/A	N/A	N/A
Czech Rep.	R'_w	≥ 53	≥ 57
Denmark	R'_w	≥ 55	≥ 55
England & Wales	$D_{nT,w} + C_{tr}$	≥ 45	≥ 45
Estonia	R'_w	≥ 55	≥ 55
Finland	R'_w	≥ 55	≥ 55
France	$D_{nT,w} + C$	≥ 53	≥ 53
Germany	R'_w	≥ 53 (4)	≥ 57
Greece (9)	R'_w	$\geq (50)$	$\geq (50)$
Hungary	$R'_w + C$	≥ 51	≥ 56
Iceland	R'_w	≥ 55	≥ 55
Ireland	$D_{nT,w}$	≥ 53 (4)	≥ 53
Italy	R'_w	≥ 50	≥ 50
Latvia	R'_w	≥ 54	≥ 54
Lithuania	$D_{nT,w}$ or R'_w	≥ 55	≥ 55
Luxembourg (8)	N/A	N/A	N/A
Macedonia FYR (8)	N/A	N/A	N/A
Malta (8)	N/A	N/A	N/A
Netherlands	$R'_w + C$	≥ 52	≥ 52
Norway	R'_w (3)	≥ 55 (3)	≥ 55 (3)
Poland	$R'_w + C$	≥ 50 (4)	≥ 52 (5)
Portugal	$D_{nT,w}$	≥ 50	≥ 50
Romania (6)	R'_w	≥ 51	≥ 51
Scotland	$D_{nT,w}$	≥ 56	≥ 56
Serbia	R'_w	≥ 52	≥ 52
Slovakia	R'_w or $D_{nT,w}$	≥ 53	≥ 57
Slovenia	R'_w	≥ 52	≥ 52
Spain	$D_{nT,A} \approx D_{nT,w} + C$	≥ 50	≥ 50
Sweden	$R'_w + C_{50-3150}$	≥ 53	≥ 53
Switzerland	$D_{nT,w} + C$	≥ 52 (7)	≥ 55
Turkey (8)	N/A	N/A	N/A

Table 2.6. Impact sound insulation between dwellings - Main requirements in 35 European countries⁽¹⁾.

Status June 2013 ⁽¹⁾		Multi-storey housing	Row housing
Country ⁽¹⁾	Descriptor ⁽²⁾	Req. [dB]	Req. [dB]
Austria	$L'_{nT,w}$	≤ 48	≤ 43
Belgium	$L'_{nT,w}$	≤ 58 (3)	≤ 50
Bulgaria	$L'_{n,w}$	≤ 53	≤ 53
Croatia	L'_{w} (5)	≤ 68	≤ 68
Cyprus (9)	N/A	N/A	N/A
Czech Rep.	$L'_{n,w}$	≤ 55	≤ 48
Denmark	$L'_{n,w}$	≤ 53	≤ 53
England & Wales	$L'_{nT,w}$	≤ 62	None
Estonia	$L'_{n,w}$	≤ 53	≤ 53
Finland	$L'_{n,w}$ (4)	≤ 53 (4)	≤ 53 (4)
France	$L'_{nT,w}$	≤ 58	≤ 58
Germany	$L'_{n,w}$	≤ 53	≤ 48
Greece (10)	$L'_{n,w}$	≤ (60)	≤ (60) 60 info
Hungary	$L'_{n,w}$	≤ 55	≤ 45
Iceland	$L'_{n,w}$	≤ 53	≤ 53
Ireland	$L'_{nT,w}$	≤ 62	None
Italy	$L'_{n,w}$	≤ 63	≤ 63
Latvia	$L'_{n,w}$	≤ 54	≤ 54
Lithuania	$L'_{n,w}$	≤ 53	≤ 53
Luxembourg (9)	N/A	N/A	N/A
Macedonia FYR (9)	N/A	N/A	N/A
Malta (9)	N/A	N/A	N/A
Netherlands	$L'_{nT,w} + C_1$	≤ 54	≤ 54
Norway	$L'_{n,w}$ (4)	≤ 53 (4)	≤ 53 (4)
Poland	$L'_{n,w}$	≤ 58	≤ 53
Portugal	$L'_{nT,w}$	≤ 60	≤ 60
Romania (7)	$L'_{n,w}$	≤ 59	≤ 59
Scotland	$L'_{nT,w}$	≤ 56	None
Serbia	$L'_{n,w}$	≤ 68	≤ 68
Slovakia	$L'_{n,w}$ or $L'_{nT,w}$	≤ 55	≤ 48
Slovenia	$L'_{n,w}$	≤ 58	≤ 58
Spain	$L'_{nT,w}$	≤ 65	≤ 65
Sweden	$L'_{n,w} + C_{1,50-2500}$	≤ 56 (6)	≤ 56 (6)
Switzerland	$L'_{nT,w} + C_1$	≤ 53 (8)	≤ 50
Turkey (9)	N/A	N/A	N/A

Notes to table 2.5

- (1) Overview information only. Detailed requirements and conditions are found in the building codes. All data to be verified/corrected in 2014. The original study for 24 countries is from 2008. Bulgaria, Croatia, Cyprus, Greece, Luxembourg, Macedonia FYR, Malta, Romania, Scotland, Serbia, Turkey are new countries added in March 2011. CZ, IS, PT have been updated 2011 due to revision of building codes. In 2013, Greece has been added; Iceland and Slovakia updated.
- (2) No generally applicable conversion between the different descriptors exists, as the relations depend on characteristics of rooms and constructions. Exact conversion can only be made in specific cases.
- (3) Recommended that the same criteria are fulfilled by $R'_w + C_{50-5000}$.
- (4) Horizontal, requirement for vertical is 1 dB higher (Bulgaria, Germany, Poland) / lower (Ireland).
- (5) 55 dB recommended.
- (6) Under revision.
- (7) Flats for rent. If owned by occupants, same limit as for row housing.
- (8) No regulatory requirements. In Luxembourg, most often limits from Belgium or other neighbouring countries are applied, dependant on the consultant. In Turkey, requirements in preparation.
- (9) Proposed requirements, not yet mandatory.
- (10) Although England & Wales and Scotland are parts of UK, they are listed as separate countries due to different requirements.

Notes to table 2.6

- (1) Overview information only. Detailed requirements and conditions are found in the building codes. All data to be verified/corrected in 2014. The original study for 24 countries is from 2008. Bulgaria, Croatia, Cyprus, Greece, Luxembourg, Macedonia FYR, Malta, Romania, Scotland, Serbia, Turkey are new countries added in March 2011. CZ, IS, PT have been updated 2011 due to revision of building codes. In 2013, Greece has been added; Iceland and Slovakia updated.
- (2) No generally applicable conversion between the different descriptors exists, as the relations depend on characteristics of rooms and constructions. Exact conversion can only be made in specific cases.
- (3) From "non-bedrooms" outside the dwelling to a bedroom ≤ 54 dB is required.
- (4) Recommended that the same criteria are fulfilled by $L'_{n,w} + C_{1,50-2500}$.
- (5) L'_w not defined in ISO 717-2. It is assumed to be $L'_{n,w}$.
- (6) The same criteria shall also be fulfilled by $L'_{n,w}$.
- (7) Under revision.
- (8) Flats for rent. If owned by occupants, same limit as for row housing.
- (9) No regulatory requirements. In Luxembourg, most often limits from Belgium or other neighbouring countries are applied, dependant on the consultant. In Turkey, requirements in preparation.
- (10) Proposed requirements, not yet mandatory.
- (11) Although England & Wales and Scotland are parts of UK, they are listed as separate countries due to different requirements.

Table 2.7. Main findings from comparison of requirements in 35 countries in Europe, 2013.

Airborne sound insulation	Impact sound insulation
<ul style="list-style-type: none"> • 7 descriptors + variants/ recommendations • For multi-storey housing differences up to 6 dB • For row housing differences up to 10 dB • 8 countries apply C-terms • Low-frequency C-terms applied only in Sweden • The strictest requirements for are found in Scotland and Austria for multi-storey and row housing, respectively • 5 countries have no requirements 	<ul style="list-style-type: none"> • 5 descriptors + variants/ recommendations • For multi-storey housing max difference > 15 dB • For row housing max difference > 20 dB • 3 countries apply C-terms • Low-frequency C-terms applied only in Sweden • The strictest requirements are found in Austria for both for multi-storey and row housing • 5 countries have no requirements

In regulatory terms, a significant challenge is that for some types of light-weight constructions, the subjective sound insulation is ranked lower than for a heavy construction with the same objective sound insulation. Regulatory requirements are objective, and the same requirements should be applicable for all types of housing constructions and materials. Thus, an important research task is to develop new objective descriptors (evaluation methods) correlating with the subjective evaluation for all types of constructions. – In Norway, a survey [18] about satisfaction with newly built homes (2005) has been carried out in 2007. In general, people are satisfied (about 80%, 10% dissatisfied). Least satisfaction (17% dissatisfied) is found with sound insulation, especially for 2-storey housing (27% dissatisfied). According to [19], the reason is likely to be light-weight constructions applied for such housing.

Requirements for facade sound insulation

This paper focuses on sound insulation between dwellings, and only general principles for facade sound insulation requirements will be dealt with. As shown in Table 2.3, there are 27 facade sound insulation descriptors based on ISO 717 [11]. However, regulatory requirements for facade sound insulation can be expressed in more ways, directly or indirectly:

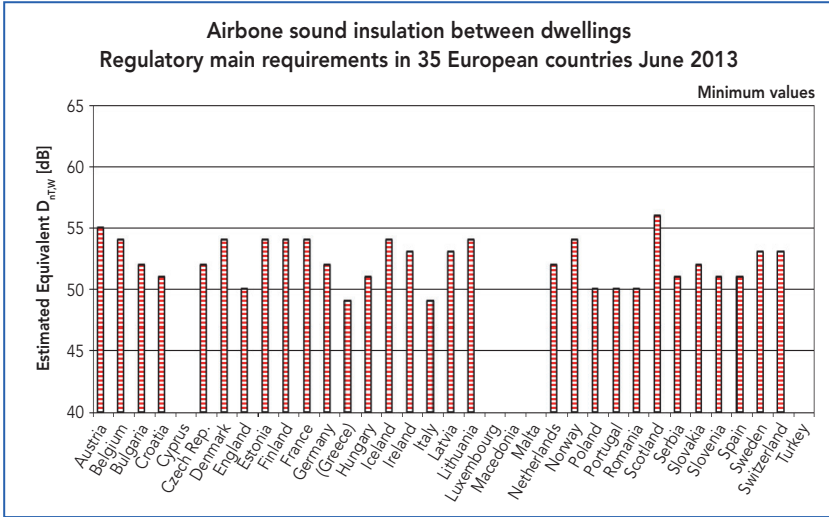

Figure 2.2. Overview of airborne sound insulation requirements between dwellings. Graphical presentation of estimated equivalent values of $D_{nT,W}$. Note: The equivalent values are estimates only, as exact conversion is not possible, see Ch. 4.

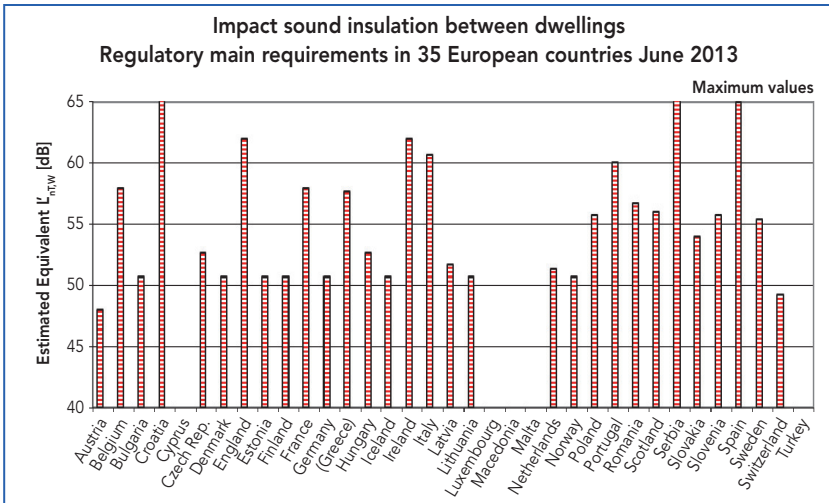

Figure 2.3.* Overview of impact sound insulation requirements between dwellings. Graphical presentation of estimated equivalent values of $L'_{nT,W}$. Note: The equivalent values are estimates only, as exact conversion is not possible, see Ch. 4.

* Figures 2.3 and 2.4 revised October 2016.

- Minimum facade sound insulation as a function of outdoor noise level (e.g. FR, DE, LT, NL, AT)
- Max indoor noise levels (e.g. DK, FIN, IS, NO, SE)
- Max “night event” levels - combined with other criteria (e.g. NO, SE)

Consequently, descriptors related to regulations for sound insulation against traffic noise are not always defined in ISO 717. Nevertheless, all methods lead to sound insulation requirements for the facade components. The required sound insulation depends on the outdoor noise level and maximum indoor level. The outdoor noise levels are calculated based on the traffic data and conditions. Often, the traffic noise levels are available from authorities. The levels vary with location, see Figure 2.4.

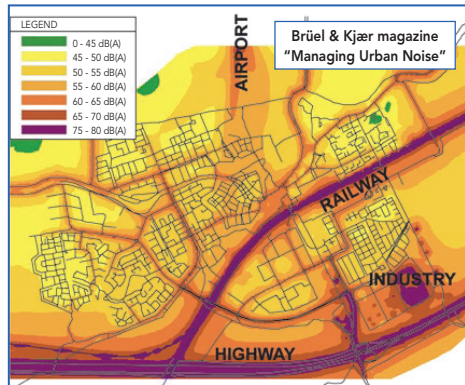

Figure 2.4.* Example of mapping of outdoor noise from road traffic, railways, airports and industry. The regulatory sound insulation requirement for facades depends on the outdoor level and thus of the location.

Figure 2.5 shows housing facing a busy road. The housing blocks behind those facing the road are less exposed to traffic noise, and thus requirements could be less strict.

Noise mapping and action plans are mandatory according to the European Environmental Noise Directive (END), [20]. A strategy for a quieter Europe is presented in [21]. In several countries, facade sound insulation requirements are specified as a function of the outdoor traffic noise levels calculated according to other methods than defined in the END [20], and in some countries there are additional limits for night events. When reviewing such limits, the WHO night noise guidelines in [22] might be useful.

* Figures 2.3 and 2.4 revised October 2016.



Figure 2.5. Housing block facing a busy road.

Like requirements for sound insulation between dwellings, the situation seems quite chaotic, when trying to exchange experience between countries.

2.5. Sound classification schemes in Europe

Sound classification schemes describe different quality classes to meet different needs of activities and quietness in the home. In this chapter a classification scheme is understood as a set of minimum 3 classes with different sound insulation performance levels. Using this definition, classification schemes for dwellings exist at present in 10 countries in Europe [23-32]. In Germany, an additional recommendation [33] has been prepared. The first classification schemes for dwellings were implemented in the early 1990s. Sound classification schemes in Europe are national schemes, the majority being published by national standardization organizations, see Figure 2.6. An overview of existing sound classification schemes for dwellings [23-32] is found in Table 2.8. For each scheme, information is found about class denotations, relation to the national building code and the classes intended for new and for existing (old/renovated and other not new) housing, respectively. The schemes specify class criteria concerning several acoustic aspects. The schemes and main class criteria are described in more detail in [8-9], for facades in [34, 36]. Aspects related to sound classes for renovated housing are described in [35]. More schemes are under development in other countries, unfortunately different from and not coordinated with update of other schemes in Europe.

The different classes in the classification schemes are intended to reflect different levels of acoustical comfort. Thus, to be able to make a qualified choice of sound class, it is of course relevant to know the degree of acoustical comfort or occupants' satisfaction for the respective classes. For this reason, it has been found important to include such indications in the TU0901 proposal for a classification scheme, see Chapter 5.

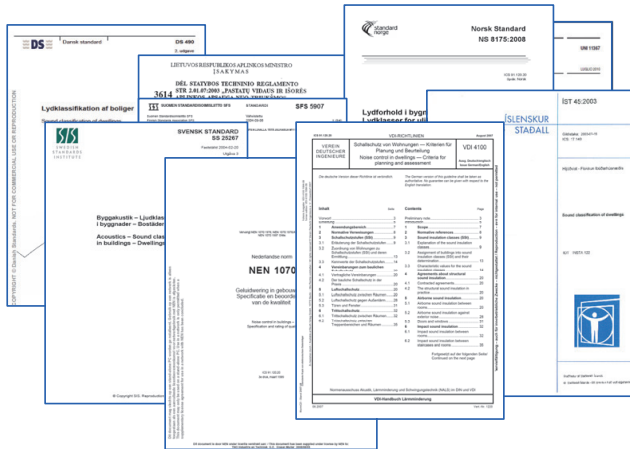

Figure 2.6. Most classification schemes in Europe are published by national standardization organizations. Only in Germany, the scheme is published by “private” organizations. An overview of schemes is found in Table 8.

Table 2.8. European schemes for sound classification of dwellings, relation to building codes and indication of classes intended for new and “old” dwellings. Status June 2013.

Country	Class denotations ⁽¹⁾	CS Reference (latest version)	Link BC to CS	BC Reference to CS	Comment	Classes for new dwellings	Classes for “old” dwellings
DK	A / B / C / D	DS 490 (2007)	+	Class C		A, B, C	D
FI	A / B / C / D	SFS 5907 (2004)	–	N/A	BC = Class C	A, B, C	D
IS	A / B / C / D	IST 45 (2011)	+	Class C		A, B, C	D
NO	A / B / C / D	NS 8175 (2012)	+	Class C		A, B, C	D
SE	A / B / C / D	SS 25267 (2004)	+	Class C		A, B, C	D
LT	A / B / C / D / E	STR 2.01.07 (2003)	+	Class C		A, B, C	D, E
IT	I / II / III / IV	UNI 11367 (2010)	–	N/A	BC – Class III	I / II / III / IV	
DE ⁽²⁾	III / II / I	VDI 4100 (2012) ⁽³⁾	–	N/A		III, II, I	None
AT	A / B / C / D / E	ÖNORM B 8115-5 (2012)	–	N/A	BC = Class C	A, B, C	D, E
NL	I / II / III / IV / V	NEN 1070 (1999)	–	N/A	BC – Class III	I / II / III	IV, V
“TU0901”	A – F and npd	TU0901 Conf.Book (2013)	N/A	N/A	(4)	A / B / C / D /	E / F and npd

Abbreviations: BC = Building Code (regulatory requirements); CS = Classification scheme

(1) Classes are indicated in descending order, i.e. the best class first.

(2) Moreover, the German Society of Acoustics (DEGA) has published a recommendation [17] for acoustic labelling of dwellings. The system has seven classes A*-F and a colour code, the lower classes intended for old buildings.

(3) The revised version of VDI 4100 published in 2012 changed descriptors from R'_{w} and $L'_{n,w}$ to $D_{n,T,w}$ and $L'_{n,T}$, as had been discussed for years for the regulations. Also the class criteria were made stricter, and all classes are now above regulation (before the lowest class corresponded to regulations).

(4) Proposal prepared by TU0901, see Ch. 5. Considered to be submitted as WIs for international standardization.

Comparing the data from the 10 classification schemes in Europe, see Table 2.8, Figures 2.7-2.8 and detailed class criteria in [9], several differences are found:

- Number of quality classes (3 to 5) and denotations (see table 2.8)
- Range of quality classes (8-20 dB for airborne, 14-20 dB for impact) and position
- Intervals between classes (3-6 dB for airborne, 2-10 dB for impact)
- Descriptors used for sound insulation criteria
- Use of low-frequency spectrum adaptation terms according to ISO 717:2013 [11]
- Common or separate quality levels for multi-storey and row housing
- Relation to regulatory requirements

The majority of the classification schemes include criteria for sound insulation internally in dwellings, see [8, 36] and [23-32].

The most striking differences between countries and between classes are found in impact sound criteria, e.g. the best class in [30] corresponds approximately to the lowest class in [31] and [32], see Figure 2.8 and [9].

When comparing the information in Table 2.8, some schemes may appear similar, eg NL and IT, but they are very different. Even the Nordic schemes are more different than they appear from Table 2.8, see [36].

Based on a comparison of the existing schemes, it seems as if a European proposal could be a scheme having 4 or 5 classes with about 4 dB intervals between airborne classes and about 5 dB intervals between impact classes. A key issue is whether low-frequency rating should be included in all classes or maybe only the upper classes. Results of discussions are found in the scheme presented in Ch. 5.

2.6. Is harmonization of sound insulation descriptors and classes possible?

Looking into the future, harmonization of sound insulation requirements seems unrealistic. However, by reducing the number of sound insulation descriptors and by preparing a harmonized European classification scheme with a number of quality classes, each member state could select for regulations a "harmonized" class fitting the national needs and conditions. Having said that, it must be emphasized that there are big jungles to be removed, before "transparent" limits can be implemented.

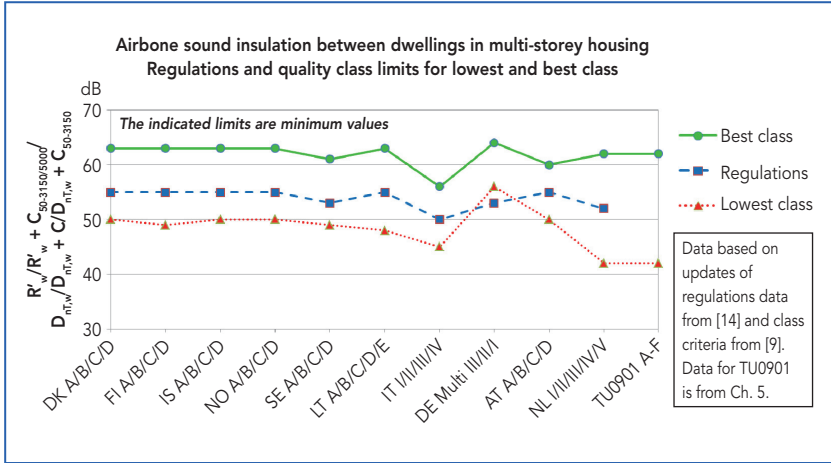

Figure 2.7. Airborne sound insulation limits for highest and lowest classes in 10 classification schemes in Europe and regulatory requirements for the same countries. TU0901 class limits for highest and lowest class shown in the right side for comparison. Note: The diversity of descriptors appears from the Y-axis label. The graphs present the numbers only. No conversions between descriptors have been applied.

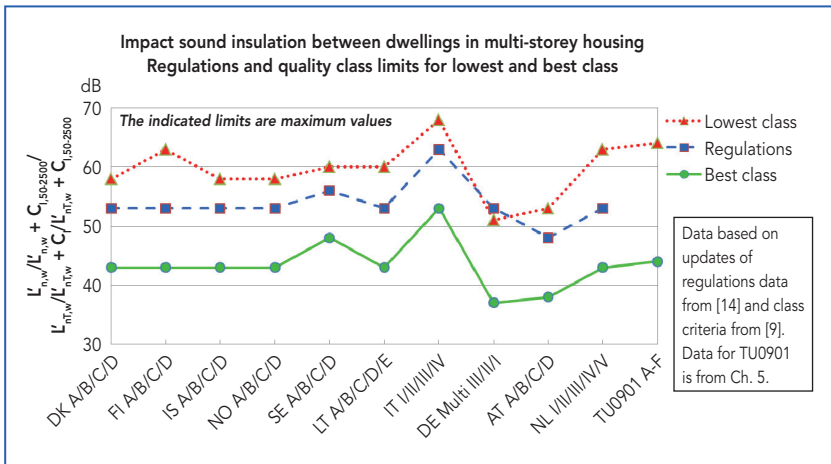

Figure 2.8. Impact sound insulation limits for highest and lowest classes in 10 classification schemes in Europe and regulatory requirements for the same countries. TU0901 class limits for highest and lowest class shown in the right side for comparison. Note: The diversity of descriptors appears from the Y-axis label. The graphs present the numbers only. No conversions between descriptors have been applied.

Jungles to be removed – Replanting forbidden!

Jungle 1: The variety of standardized sound insulation descriptors, see EN ISO 717 [11].

Jungle 2: Complex national rules making it difficult to find the limit values, see [15].

Jungle 3: National special rules in addition to standardized methods, see [16, 17].

Implementation and enforcement of sound insulation requirements

Important tasks and tools for upgrading sound insulation requirements and to make an efficient and effective implementation in practice are:

- Review of national requirements and upgrade, if needed
- Construction databases and guidelines for improvement of existing housing
- Construction databases and guidelines for new housing
- Enforcement of regulations
- Feedback from field testing

Examples of guidelines and enforcement

Examples of instructions for improvement of existing/old housing are found in Figure 2.9. For new buildings, “Robust Details” [37] implemented in UK is an example of a coordinated approach, including construction design, acoustic site inspection, checklists, field testing and systematic feedback to the design and performance review. In practice, Robust Details supports enforcement. Examples of construction details and checklists are shown in Figure 2.10.

It seems as if all the necessary tools and experience exist to get the change process and implementation started. When a single national committee struggles on its own, the full process would typically take 10-20 years or even more – or never happen. However, by using the network established through COST TU0901, exchange of experience has already started, and the process and implementation could run much more effectively and efficiently.

There are of course still research needs, but these could be defined now on a better ground and joint projects could be applied for and thus prepare the ground for continued innovation, exchange of experience and dissemination of findings.

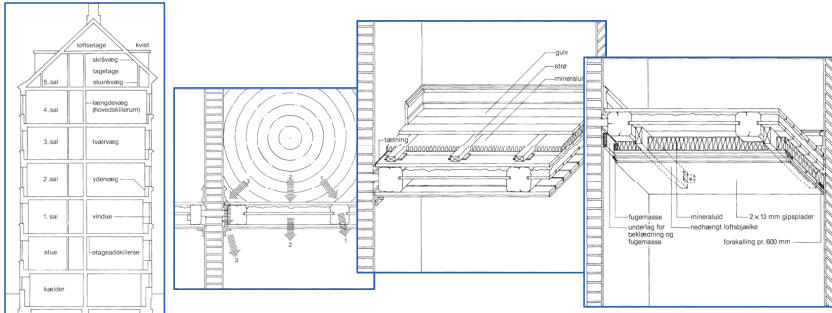

Figure 2.9. Examples on instructions for improvement of sound insulation of old housing. Source: SBi Guidelines 173, Sound insulation of buildings – Old buildings, 1992 (in Danish).

According to [38], the coordinated approach in Robust Details [37] “can lead to an accelerated uptake in improved construction practice and allow government policy performance objectives to be met sooner”. Thus, there is a high potential.

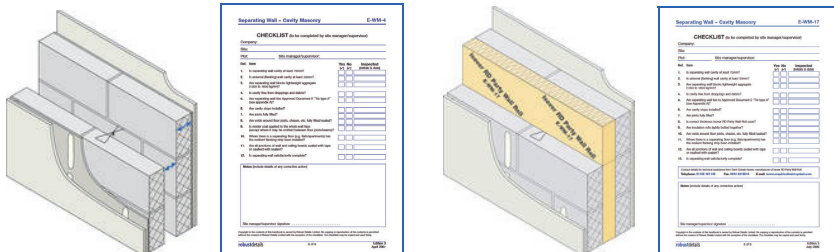

Figure 2.10. Examples construction details and related checklists from Robust Details [37].

2.7. Conclusions and acknowledgements

Most European countries have regulatory sound insulation requirements for dwellings, and classification schemes exist in several countries. However, both descriptors, requirements and class criteria present a high degree of diversity. Unfortunately, there is no sign of increasing harmonization, rather the contrary, i.e. evidence for an even more diverse situation in Europe. The studies conclude that harmonization of descriptors and sound insulation classes is needed to facilitate exchange of data and experience between countries, thus improving chances of better quality of dwellings, to stimulate innovation and to reduce trade barriers. Most

important is, however, that review and update/upgrade of sound insulation requirements should be initiated in several countries to adapt regulations to current construction trends and peoples' needs for health, wellbeing and comfort.

The authors - Chair and Vice Chair of TU0901 – are grateful to all those enthusiastic people from many countries being active in TU0901: The WG leaders, the MC and WG members, in total nearly 100 people from 29 countries in Europe and three overseas countries. In addition: Thanks to COST Office for support.

COST TU0901 has – through members with different academic backgrounds (architects, physicists, civil engineers etc.) and from different types of institutions (universities, building research institutes, authorities, private companies etc.) – the potential to establish a change process in a direction ensuring strengthened scientific basis for changes in sound insulation descriptors, requirements and classes. - We eagerly anticipate collaborative developments in this field.

2.8. References

- [1] Preamble to the Constitution of the World Health Organization as adopted by the International Health Conference, New York, 19 - 22 June 1946; signed on 22 July 1946 by the representatives of 61 states (official Records of the World Health Organization, No. 2, p. 100) and entered into force on 7 April 1948.
- [2] <http://www.euro.who.int/>
- [3] Van den Berg, M. *"Neighbour Noise: A rational Approach"*, pp. 151-154 in Proceedings of the 2nd WHO International Housing and Health Symposium. WHO, Bonn (2004).
- [4] J Lang, R Pierrard, W Schönböck, *"Sound Insulation in Housing Construction"*, TU Wien, Vienna, July 2006. A summary is found in J Lang (2007), *"Schallschutz im Wohnungsbau"*. WKS 59/2007.
- [5] <http://www.europa.eu>
- [6] B Rasmussen, *"Sound insulation between dwellings – Requirements in building regulations in Europe"*. Applied Acoustics, 2010, 71(4), 373-385. <http://dx.doi.org/10.1016/j.apacoust.2009.08.011>
- [7] B Rasmussen & JH Rindel *"Sound insulation between dwellings – Descriptors in building regulations in Europe"*. Applied Acoustics, 2010, 71(3), 171-180. <http://dx.doi.org/10.1016/j.apacoust.2009.05.002>

- [8] B Rasmussen, *“Sound insulation of residential housing - Building codes and classification schemes in Europe”*. Chapter 114 in Handbook of Noise and Vibration Control. Wiley & Son, USA, 2007.
- [9] B Rasmussen, *“Sound Classification of Dwellings – Quality Class Ranges and Class Intervals in National Schemes in Europe”*. EuroNoise 2012, Prague, Czech Republic, 2012. [http://vbn.aau.dk/en/persons/birgit-rasmussen\(c0e774a9-8cdf-410f-8727-6a2cc11a4f14\)/publications.html](http://vbn.aau.dk/en/persons/birgit-rasmussen(c0e774a9-8cdf-410f-8727-6a2cc11a4f14)/publications.html)
- [10] COST Action TU0901 *“Integrating and Harmonizing Sound Insulation Aspects in Sustainable Urban Housing Constructions”*, 2009-2013. see www.costtu0901.eu/ (Action website) and www.cost.eu/domains_actions/tud/Actions/TU0901 (public information at COST website).
- [11] ISO 717, Acoustics - Rating of sound insulation in buildings and of buildings elements. – Part 1: Airborne sound insulation, 2013. – Part 2: Impact sound insulation, 2013.
- [12] ISO 140, Acoustics – Measurement of sound insulation in buildings and of building elements – Part 4: Field measurements of airborne sound insulation between rooms, 1998. – Part 5: Field measurements of airborne sound insulation of facade elements and facades, 1998. – Part 7: Field measurements of impact sound insulation of building elements, 1998.
- [13] B. Rasmussen and J. H. Rindel: *“Concepts for evaluation of sound insulation of dwellings - from chaos to consensus?”* Forum Acusticum 2005, Budapest, Hungary, Paper ID 7820.
- [14] *“Sound insulation between dwellings – Overview of the variety of descriptors and requirements in Europe”*, by B. Rasmussen, Forum Acusticum 2011, Aalborg, Denmark, Paper ID 573. [http://vbn.aau.dk/en/persons/birgit-rasmussen\(c0e774a9-8cdf-410f-8727-6a2cc11a4f14\)/publications.html](http://vbn.aau.dk/en/persons/birgit-rasmussen(c0e774a9-8cdf-410f-8727-6a2cc11a4f14)/publications.html)
- [15] V Desarnaulds and B Rasmussen, *“Harmonisation des réglementations européennes dans le domaine de l’isolation acoustique dans le bâtiment (COST TU0901”*. 10ème Congrès Français d’Acoustique, Lyon, 12-16 Avril 2010.
- [16] Heikki Helimäki and Birgit Rasmussen, *“Airborne sound insulation descriptors in the Nordic building regulations – Overview special rules and benefits of changing descriptors”*. Baltic-Nordic Acoustics Meeting 2010, Bergen, Norway. SINTEF Byggforsk, 2010.
- [17] Klas Hagberg and Birgit Rasmussen, *“Impact sound insulation descriptors in the Nordic building regulations – Overview special rules and benefits of changing descriptors”*. Baltic-Nordic Acoustics Meeting 2010, Bergen, Norway. SINTEF Byggforsk, 2010.

- [18] Barlindhaug, Rolf, & Ruud, Marit Ekne. *“Beboernes tilfredshet med nybygde boliger”* (Resident satisfaction with newly built homes). Norsk institutt for by- og regionforskning. NIBR-rapport 2008:14, Oslo 2008.
- [19] Sigurd Hveem, *“Unngå byggsaker – Lydisolasjonskvalitet i boliger”* (Avoid building faults – Sound insulation quality in dwellings). SINTEF Byggforsk, 2010. <http://www.sintef.no/upload/Artikkel-05-10-ByggAktuelt.pdf>. Note: This article summarizes main findings about sound insulation from [18].
- [20] “European Directive 2002/49/EC of 25 June 2002 relating to the assessment and management of environmental noise”. Note: Often referred to as the Environmental Noise Directive or END. Europe - Environment - Noise Policy, <http://ec.europa.eu/environment/noise/directive.htm>
- [21] “Research for a Quieter Europe in 2020”. An updated strategy paper of the CALM network. European Commission. Research Directorate - General, 2007.
- [22] «Night noise guidelines for Europe». Copenhagen, WHO Regional Office for Europe, 2009. http://www.euro.who.int/eprise/main/WHO/Progs/NOH/Activities/20040721_1
- [23] DS 490:2007, “Lydklassifikation af boliger”. (Sound classification of dwellings), DK.
- [24] SFS 5907:2004, “Rakennusten Akustinen Luokitus”, Finland. English version “Acoustic classification of spaces in buildings” published in July 2005.
- [25] IST 45:2011, “Hljjóðvist – Flokkun íbúðarog atvinnuhúsnæðis” (Acoustic conditions in buildings - Sound classification of various types of buildings”, Icelandic Standards, Iceland).
- [26] NS 8175:2012, “Lydforhold i bygninger, Lydklasser for ulike bygningstyper” (Acoustic conditions in buildings - Sound classification of various types of buildings). Standards Norway.
- [27] SS 25267:2004, “Byggakustik – Ljudklassning av utrymmen i byggnader – Bostäder”. (Acoustics – Sound classification of spaces in buildings – Dwellings). Sweden.
- [28] STR 2.01.07:2003, Dėl Statybos Techninio Reglamento Str 2.01.07:2003, “Pastatu Vidaus Ir Isores Aplinkos Apsauga Nuo Triuksmo” (Lithuanian building regulations. Protection against noise in buildings). Patvirtinimo, Lithuania.
- [29] NEN 1070:1999, “Geluidwering in gebouwen – Specificatie en beoordeling van de kwaliteit” (Noise control in buildings – Specification and rating of quality), Netherlands.
- [30] UNI 11367:2010 Acustica in edilizia – Classificazione acustica delle unità immobiliari – Procedura di valutazione e verifica in opera (Building Acoustics

- Acoustic classification of building units - Evaluation procedure and in-situ measurements)
- [31] VDI 4100:2012, "Schallschutz im Hochbau - Wohnungen - Beurteilung und Vorschläge für erhöhten Schallschutz" (Sound insulation between rooms in buildings - Dwellings - Assessment and proposals for enhanced sound insulation between rooms". Verein Deutscher Ingenieure, VDI-Handbuch Lärminderung. Beuth, Germany.
- [32] ÖNORM B 8115-5:2012 – Schallschutz und Raumakustik im Hochbau - Teil 5: Klassifizierung. ÖNORM, Austria.
- [33] DEGA-Empfehlung 103, "Schallschutz im Wohnungsbau – Schallschutzausweis", DEGA, March 2009. <http://dega-schallschutzausweis.de/>
- [34] B Rasmussen, "Facade sound insulation comfort criteria in European classification schemes for dwellings", EuroNoise 2006, Tampere, Finland, Paper ID 434.
- [35] B Rasmussen, "*Sound classification schemes in Europe - Quality classes intended for renovated housing*". SUBURBAN 2010 "Improving the Quality of Suburban Building Stock". University of Malta, 2010. COST TU0701 Midterm Conference.
- [36] B. Rasmussen. "*Sound classification of dwellings in the Nordic countries – Differences and similarities between the five national schemes*" by BNAM 2012, Odense, Denmark. [http://vbn.aau.dk/en/persons/birgit-rasmussen\(c0e774a9-8cdf-410f-8727-6a2cc11a4f14\)/publications.html](http://vbn.aau.dk/en/persons/birgit-rasmussen(c0e774a9-8cdf-410f-8727-6a2cc11a4f14)/publications.html)
- [37] Robust Details, <http://www.robustdetails.com/>. Definition of RD: see <http://www.robustdetails.com/Robust-Details-for-Part-E-separating-walls-or-floors-sound-insulation-and-testing-Robust-Details-Limited-65d22b1>
- [38] S Smith, D Baker, R Mackenzie, J B Wood, P Dunbavin, D Panter, "*The development of robust details for sound insulation in new build attached dwellings*". J Build Appraisal 2006;2 (1):69–85.