



AALBORG UNIVERSITY
DENMARK

Aalborg Universitet

Towards the Twin Transformation

A View on Designing Circular and Digital Organisations

Uhrenholt, Jonas Nygaard

DOI (link to publication from Publisher):
[10.54337/aau515133454](https://doi.org/10.54337/aau515133454)

Publication date:
2022

Document Version
Publisher's PDF, also known as Version of record

[Link to publication from Aalborg University](#)

Citation for published version (APA):
Uhrenholt, J. N. (2022). *Towards the Twin Transformation: A View on Designing Circular and Digital Organisations*. Aalborg Universitetsforlag. <https://doi.org/10.54337/aau515133454>

General rights

Copyright and moral rights for the publications made accessible in the public portal are retained by the authors and/or other copyright owners and it is a condition of accessing publications that users recognise and abide by the legal requirements associated with these rights.

- Users may download and print one copy of any publication from the public portal for the purpose of private study or research.
- You may not further distribute the material or use it for any profit-making activity or commercial gain
- You may freely distribute the URL identifying the publication in the public portal -

Take down policy

If you believe that this document breaches copyright please contact us at vbn@aub.aau.dk providing details, and we will remove access to the work immediately and investigate your claim.

TOWARDS THE TWIN TRANSFORMATION

A VIEW ON DESIGNING CIRCULAR
AND DIGITAL ORGANISATIONS

BY
JONAS NYGAARD UHRENHOLT

DISSERTATION SUBMITTED 2022



AALBORG UNIVERSITY
DENMARK

TOWARDS THE TWIN TRANSFORMATION

**A VIEW ON DESIGNING CIRCULAR AND DIGITAL
ORGANISATIONS**

by

Jonas Nygaard Uhrenholt



AALBORG UNIVERSITY
DENMARK

Dissertation submitted 2022

Dissertation submitted: October, 2022

PhD supervisor: Prof. Brian Vejrum Wæhrens
Aalborg University

PhD committee: Professor Arne Remmen (chair)
Aalborg University, Denmark
Professor Chee Yew Wong
Leeds University Business School, United Kingdom
Professor Krisztina Demeter
Corvinus University of Budapest, Hungary

PhD Series: Faculty of Engineering and Science, Aalborg University

Department: Department of Materials and Production

ISSN (online): 2446-1636
ISBN (online): 978-87-7573-807-6

Published by:
Aalborg University Press
Kroghstræde 3
DK – 9220 Aalborg Ø
Phone: +45 99407140
aauf@forlag.aau.dk
forlag.aau.dk

© Copyright: Jonas Nygaard Uhrenholt

Printed in Denmark by Stibo Complete, 2022



CV

Jonas Nygaard Uhrenholt was born in Drigstrup, Denmark, in 1993. From 2014, he studied management engineering at Aalborg University, receiving his B.Sc. in Global Business Engineering in 2017, followed by an M.Sc. in Operations and Innovation Management in 2019. Since August 2019, he has been a Ph.D. fellow at Aalborg University's Department of Materials and Production as a part of the Center of Industrial Production. During his Ph.D. studies, he collaborated with RTO Force Technology in their IoT, Data & Services Innovation department. His research on the role of digital technologies in the context of the circular economy is part of the Innovation Factory North (IFN), funded by the European Regional Development Fund and the University College of Northern Denmark.

ENGLISH SUMMARY

The call for a more sustainable way of living, as a consequence of the increasing climate crisis, has left its mark on the academic discourse, international forums, and industrial agenda in the past decade. Throughout this decade, the circular economy discourse has emerged as an economic model with the purpose of decoupling resource consumption from value creation. At the same time, the rapid development of digital technologies, as part of the industry 4.0 agenda, has brought the world closer through its emphasis on transparency and data availability across entire supply chains. Most recently, the two discourses are being discussed for their mutually beneficial properties – This synergetic relation between circular economy and industry 4.0 is currently coined as the twin transformation.

Despite the increasing attention to the circular economy agenda, the industry 4.0 agenda, and now also the twin transformation agenda, manufacturers are challenged in adopting its principles and building the capabilities required to realise performance improvements accordingly. Manufacturers are struggling with identifying and utilising the structural elements of this agenda to drive their organisational transformation and build sustained competitiveness.

This research aims to address these challenges faced in this agenda by generating knowledge and developing frameworks for guiding the industrial engagement of the twin transformation. Accordingly, this research project aims to contribute to the existing knowledge body while providing relevance to practitioners by facilitating a deeper and more nuanced understanding of the twin transformation according to the following objectives. To provide:

An understanding of the structural elements of the twin transformation and how they can be utilised to drive the transformation to build competitive advantage in the changing industrial context.

Frameworks and guidelines for supporting the successful engagement with the twin transformation.

This dissertation, a collection of papers, presents the research activities conducted over the past three years. The appended papers represent both desk research and empirically based research, all aiming to balance the rigour of providing academic contributions with the relevance of aiding the industry in this transformation.

The dissertation is divided into three parts. The first part empirically investigates the synergetic relation between the internet of things (representing industry 4.0) and circular economy, according to ten Danish manufacturers in the early stages of their twin transformation. Additionally, a single case study investigates the contextual dependencies of barriers to circular economy transformation. The second part investigates the circular economy transformation structural elements and proposes frameworks for formulating circular economy transformation strategies. The third and final part investigates and proposes frameworks for how manufacturers can explore and exploit the use of internet of things technology in the context and pursuit of circular economy principles.

The first part suggests that the internet of things and circular economy are synergetic as the internet of things enables the generation of the data required to engage in circular economy strategies, while the perception and evaluation of the internet of things are elevated to a strategic perspective when perceived in the context of the circular economy agenda. Additionally, the interdependencies in circular economy barriers suggest that lacking competencies, inspiration, and direction in the form of a vision are preceding more technical barriers to realising performance improvements according to circular economy principles.

The second part suggests that manufacturers must work in six organisational dimensions to achieve a systems perspective in their circular economy transformation, i.e. to elevate their circular economy maturity level. At the same time, they must be aware of the meso and macroeconomic levels in which they have less decision-making power, as their financial performance of circular activities depends on these levels. Additionally, the investigation of interdependencies among barriers to transformation enables the identification of root causes and directs actions and attention accordingly.

The third part suggests how manufacturers can organise, explore and exploit activities for introducing internet of things technology that fit the particular context. In exploring the internet of things, explicit emphasis on medium- and long-term potentials relieves the technology from the traditionally hindering 2-year payback requirements, as it is perceived from an increasingly strategic perspective.

DANSK RESUME

Behovet for en mere bæredygtig måde at leve på, som en konsekvens af den stigende klimakrise, har i det seneste årti sat sit præg på den akademiske diskurs, i transnationale fora, og i den industrielle dagsorden. I dette årti har diskursen omkring Cirkulær Økonomi fundet indpas som en økonomisk model med formål at afkoble ressourceforbrug fra værdiskabelse. Samtidig har den hurtige udvikling af digitale teknologier, fra den fjerde industrielle revolution, bragt verden tættere grundet dets fokus på gennemsigthed og tilgængelighed af data på tværs af hele forsyningskæder. Senest er disse to agendaer diskuteret i sammenhæng grundet deres synergiske potentialer. Dette indbyrdes forhold mellem cirkulær økonomi og industri 4.0 er nyligt introduceret som 'twin transformation'.

På trods af den stigende opmærksomhed, både på agendaen for cirkulær økonomi, for industri 4.0 og nu også for 'twin transformation', er produktionsvirksomheder udfordret i at implementere dets principper samt at opbygge de nødvendige kapabiliteter for at realisere performance forbedringer. Produktionsvirksomheder er udfordret i at identificere de strukturelle elementer af denne agenda, samt at sætte dem i spil til at drive deres organisatoriske transformation og opbygning af konkurrenceevne deraf.

Formålet med dette forskningsprojekt er at adressere disse udfordringer, som produktionsvirksomheder står overfor i denne agenda, ved at opbygge viden og udvikle rammeværktøj til at vejlede den industrielle omstilling ind i 'twin transformation'. Således er formålet med dette forskningsprojekt at bidrage til den eksisterende viden, samt at skabe relevant indsigt til praktikere ved at facilitere en dybere og mere nuanceret forståelse af 'twin transformation' i henhold til følgende mål. At tilvejebringe:

En forståelse af de strukturelle elementer i 'twin transformation', samt hvordan disse kan sættes i spil til at drive transformationen og derved opbygge konkurrencemæssige fordele i den skiftende industrielle kontekst.

Rammeværktøj og vejledning til at understøtte det succesfulde engagement i 'twin transformation'.

Denne afhandling, en samling af artikler, præsenterer de forskningsaktiviteter, der er udført de seneste tre år. De vedhæftede artikler repræsenterer resultatet af både desk research og empirisk forskning, som alle sigter efter at balancere det rigoristiske akademiske bidrag med den praktiske relevans der støtter industrien i dens transformation.

Afhandlingen opdelt i tre dele. Den første del undersøger, empirisk, den synergiske relation mellem internet of things (som repræsentant for industri 4.0) og cirkulær økonomi, ifølge ti danske producenter, der er i de tidlige stadier af deres transformation. Derudover undersøges de kontekstuelle afhængigheder af barrierer for cirkulær transformation ved én producent. Anden del undersøger de strukturelle elementer i den cirkulære transformation og foreslår rammeværktøj for formuleringen af transformationsstrategier heraf. Den tredje del undersøger og foreslår rammeværktøj for eksplorative og optimerende aktiviteter af internet of things-teknologi i den enkelte kontekst, i dets jagt på cirkulære principper.

Resultaterne af den første del peger mod at internet of things og cirkulær økonomi er synergiske, da IoT tilvejebringer generering af de data der kræves for at engagere sig i cirkulær økonomi-strategier, mens opfattelsen og evalueringen af internet of things ophøjes til et strategisk perspektiv, når det anskues i en cirkulær økonomi-kontekst. Derudover peger de indbyrdes afhængigheder i cirkulær økonomi-barrierer på, at manglende kompetencer, inspiration og retning i form af en vision går forud for mere tekniske barrierer for at realisere præstationsforbedringer i henhold til cirkulære principper.

Resultaterne af den anden del peger mod at producenter skal arbejde i seks organisatoriske dimensioner for at opnå et systemperspektiv i deres cirkulær økonomi-transformation, dvs. for at hæve deres modenhed i cirkulær økonomi. Samtidig skal de være opmærksomme på de meso- og makroøkonomiske niveauer, hvor de har mindre beslutningskraft, mens deres økonomiske resultater af cirkulære aktiviteter er afhængige af disse niveauer. Derudover muliggør metoden for undersøgelse af gensidige afhængigheder mellem barrierer identificering af rodårsager og dermed tilvejebringer direkte handlinger heraf.

Resultaterne af den tredje del peger på hvordan producenter kan organisere eksplorative og optimerende aktiviteter i den individuelle kontekst, for introduktion af internet of things-teknologi. I eksplorative aktiviteter af internet of things vil eksplicit fokus på mellem- og langsigtede potentialer løfte teknologien fra det traditionelle 2-årige tilbagebetalingskrav, idet det anskues fra et mere strategisk perspektiv.

ACKNOWLEDGEMENTS

I want to take a moment to acknowledge the people who have enabled me to complete this Ph.D. journey over the past three years.

First and foremost, I would like to express my gratitude for the Innovation Factory North project, for funding my PhD research project and for providing me with this opportunity to immerse myself in this research domain.

My supervisor Brian Vejrum Wæhrens has been instrumental in developing this research project and my professional development. I am genuinely thankful for your continuous support, trust, and engagement in my work. My unofficial co-supervisor, Jesper Hemdrup Kristensen, also deserves my gratitude for all the constructive discussions and collaboration throughout the research project. Also, thank you, Astrid, Charles, and Harry, for your support throughout the years.

To my CE and IFN PhD colleagues, thank you for our endless academic discussions and even more for all the fun we have had in and outside the office. Special thanks to Maria, Sofie, Andreas and Steffen. You have made these years an enjoyable experience for a grumpy old man like myself.

A thank you to the bright minds at Force Technology. Thank you for sharing your insights and active engagement in our shared activities. To Michele, thank you for so much more. You helped me kickstart my research studies and have been a great support ever since.

Lastly, the greatest thank you to family and friends. The amount of support you have offered, especially in times when we all needed it. To Mille, thank you for supporting me in tough times, celebrating my victories, and enduring what I suspect has been non-stop blabbering of academic nonsense. You did all of this for me in a time when we settled as a family, as we bought a house, got engaged and married, you nailed your pregnancy and blessed us with our beautiful and curious son, Theo.

Thank you!

TABLE OF CONTENTS

Chapter 1. Introduction.....	19
1.1. The Circular Economy	20
1.2. The Role of Digital Technology.....	22
1.2.1. The Enabling Technologies.....	24
1.2.2. The Internet of Things.....	25
1.3. The Twin Transformation	25
1.4. Managing the Transformation.....	28
1.5. Thesis Objectives	30
1.6. Thesis Structure.....	30
Chapter 2. Research Context	33
2.1. Research Eco-system	33
2.1.1. Danish Manufacturing Organisations – Cases A and D	35
2.1.2. Danish Large Organisation – Case B	35
2.1.3. Research and Technology Organisation – Case C.....	36
Chapter 3. Research Design	37
3.1. Philosophical Research Position	37
3.1.1. Balancing practical and Academic Relevance.....	38
3.2. Research Framework.....	39
3.3. Research Method.....	42
3.3.1. Mixed Methods	42
Chapter 4. Research Summary	45
Chapter 5. Twin Transformation engagement of Danish Manufacturers	49
5.1. Introduction.....	49
5.2. Contextualising Dependencies among Barriers to Circular Economy Transformation.....	50
5.3. Synergies between Circular Economy and Internet of Things	54
5.4. Reflections	57
Chapter 6. Designing the Circular Economy Transformation.....	59
6.1. Introduction.....	59

6.2. Designing Company-specific Circular Economy Transformation Strategies	60
6.3. Designing Financially Feasible Product Take-back Systems	65
6.4. Contextualising and Prioritising Circular Economy Barriers to Operationalise the Transformations	69
6.5. Reflections	71
Chapter 7. Exploring and Exploiting IoT for Circular Economy	73
7.1. Introduction	73
7.2. Contextualising the Design of IoT Solutions	74
7.3. Continuous Improvement of Existing IoT Solutions	77
7.4. Reflections	78
Chapter 8. Discussion	81
Chapter 9. Conclusion	83
9.1. Limitations and Future research	84
Literature list	87
Appendices	97

LIST OF FIGURES

Figure 1.1 Strategies for reducing resource flows. (a) (Bocken et al., 2016) (b) (Konietzko et al., 2020).....	21
Figure 1.2 Level of control for micro, meso, and micro economic levels. Inspired by (Uhrenholt et al.,2022b).....	22
Figure 1.3 I4.0 value drivers (Wee et al., 2015).....	24
Figure 2.1 Conceptualisation of the research eco-system (Inspired by (Møller et al., 2022b)).....	34
Figure 3.1 Terminology for practical relevance (Nicolai & Seidl, 2010)	38
Figure 3.2 Research framework	41
Figure 5.1 Interdependences among barriers to circular economy transformation (Jensen et al., 2022).....	53
Figure 5.2 Synergies between the IoT capabilities and CE strategies in the twin transformation (Uhrenholt et al., 2022a).....	56
Figure 6.1 Data collection and selection process (Uhrenholt et al., 2022c)	66
Figure 6.2 The factors affecting the financial performance, as specified in cost and value, of product take-back systems (Adapted from (Uhrenholt et al., 2022c))	68
Figure 6.3 ISM research design (Jensen et al., 2022).....	70
Figure 7.1 Example of integration of OT plotted in relation to their digital capabilities (Nygaard et al., 2020).	78

LIST OF TABLES

Table 1.1 Dimensions of the organisational CE (Uhrenholt et al., 2022b)	23
Table 1.2 Correlation between I4.0 value drivers and CE strategies	27
Table 2.1 IFN stakeholders	34
Table 2.2 Contribution of industrial cases	35
Table 3.1 Methodological choices for the six appended papers.....	44
Table 4.1 Summary of the six appended papers.....	45
Table 5.1 Identified barriers to the circular economy transformation (Jensen et al., 2022)	51
Table 5.2 Barriers to the IoT implementation (Uhrenholt et al., 2022a).....	55
Table 5.3 Barriers to the CE implementation (Uhrenholt et al., 2022a).....	55
Table 6.1 Dimensions of the organisational circular economy (Uhrenholt et al., 2022b)	61
Table 6.2 Levels of organisational maturity for the circular economy (Uhrenholt et al., 2022b)	62
Table 6.3 Circular economy reference model (Uhrenholt et al., 2022b).....	63
Table 7.1 IoT solution design framework (Colli et al., 2021b).....	75
Table 7.2 List of desired improvement goals at a case company	80

LIST OF PAPERS

- Paper 1.** Jensen, S. F., Kristensen, J. H., Uhrenholt, J. N., Rincón, M. C., Adamsen, S., & Waehrens, B. V. (2022). Unlocking barriers to circular economy: An ISM-based approach to contextualizing dependencies. *Sustainability*, 14(15), 9523.
- Paper 2.** Uhrenholt, J. N., Kristensen, Colli, M., & Waehrens, B. V. (2022a). Twin Transformation: Synergies between Circular Economy and Internet of Things– A study of Danish Manufacturers. In Review
- Paper 3.** Uhrenholt, J. N., Kristensen, J. H., Rincón, M. C., Adamsen, S., Jensen, S. F., & Waehrens, B. V. (2022b). Maturity Model as a Driver for Circular Economy Transformation. *Sustainability*, 14(12), 7483.
- Paper 4.** Uhrenholt, J. N., Kristensen, J. H., Rincón, M. C., Jensen, S. F., & Waehrens, B. V. (2022c). Circular economy: Factors affecting the financial performance of product take-back systems. *Journal of Cleaner Production*, 335, 130319.
- Paper 5.** Colli, M., Uhrenholt, J. N., Madsen, O. and Waehrens, B.V. (2021b). Translating transparency into value: an approach to design IoT solutions. *Journal of Manufacturing Technology Management*, Vol. 32 No. 8, pp. 1515-1532
- Paper 6.** Nygaard, J., Colli, M., & Wæhrens, B. V. (2020). A self-assessment framework for supporting continuous improvement through IoT integration. *Procedia Manufacturing*, Vol. 42, pp. 344-350.

Contribution Report

- Paper 1.** Co-author. Contributor to conceptualisation, manuscript review and editing
- Paper 2.** Main Author. Primary contributor to conceptualisation, methodology, literature review, data collection, formal analysis, manuscript draft, manuscript review and editing.
- Paper 3.** Main author. Primary contributor to conceptualisation, methodology, literature review, formal analysis, manuscript draft, manuscript review and editing.

- Paper 4.** Main author. Primary contributor to conceptualisation, methodology, literature review, formal analysis, manuscript draft, manuscript review and editing.
- Paper 5.** Co-author. Contributor to literature review, data collection, manuscript review and editing
- Paper 6.** Main author. Primary contributor to conceptualisation, methodology, literature review, formal analysis, manuscript draft, manuscript review and editing.

CHAPTER 1. INTRODUCTION

Climate change is “the defining issue of our time”, as the UN¹ delicately puts it. The temperature of our planet is rising, major cities are threatened by ‘Day Zero’², ecosystems are dying, and many more environmental crises are all evidence that the self-preservation of the earth is at risk^{3,4}. The common denominator of these crises is the call for more sustainable ways of living.

Ever since Henry Ford offered the Model T in every colour “as long as it’s black” (Ford & Crowther, 1922), societies’ industrialisation has focused on economic growth with little regard for the environment. This industrial setting is known as the linear economy in which the one-way ‘take-make-dispose’ configuration characterises the flow of resources. In this industrial configuration, resources are assumed infinite. At the same time, fossil fuel use is the primary energy source, and the organisational value proposition is based on the transfer of ownership. As a result, the industry favours overproduction, short life cycles, and waste.

However, it is well-established that resources are finite and that the current configuration of our industrialized society is not sustainable, e.g. as illustrated by the ‘Earth Overshoot Day’⁵, which fell on July 29th in 2021. Also, in academia, the finite state of resources is not novel. In 1966, Boulding figuratively painted two pictures of the earth as an open system and a closed system: “cowboy economy” and “spaceman economy”. The cowboy roams the open plains with no constraints, which fosters its reckless and exploitative nature. The spaceman is limited to the resources available in their spaceship; hence, they live in a closed system (Boulding, 1966). This distinction between the open and closed systems is acknowledged throughout the academic discourse, most recently in the rapidly growing circular economy (CE) domain. CE builds and consolidates on previous, not to confuse outdated, schools of thought such as industrial ecology (e.g. Erkman, 1997), cradle to cradle (e.g. McDonough & Braungart, 2010), blue economy (e.g. Pauli, 2010), and cleaner production (e.g. Lieder & Rashid, 2016).

¹ <https://www.un.org/en/sections/issues-depth/climate-change/index.html>

² “Day Zero”: The day when the municipal water supply for a major city is estimated to run out.

³ <https://climate.nasa.gov>

⁴ https://www.wwf.dk/wwfs_arbejde/klimaenergi/klima_og_forbrug/living_planet_report/

⁵ “Earth Overshoot Day marks the date when humanity’s demand for ecological resources and services in a given year exceeds what Earth can regenerate in that year” (<https://www.overshootday.org/about-earth-overshoot-day/>)

1.1. THE CIRCULAR ECONOMY

CE is subject to various yet similar definitions as an emerging research domain experiencing exponential growth in research attention. Nobre & Tavares (2021) address this issue by analysing the multitude of existing definitions combined with surveying researchers working in the domain. As a result, they find and propose the following as a “final definition of circular economy”:

“Circular Economy is an economic system that targets zero waste and pollution throughout materials lifecycles, from environment extraction to industrial transformation, and to final consumers, applying to all involved ecosystems. Upon its lifetime end, materials return to either an industrial process or, in case of a treated organic residual, safely back to the environment as in a natural regenerating cycle. It operates creating value at the macro, meso and micro levels and exploits to the fullest the sustainability nested concept. Used energy sources are clean and renewable. Resources use and consumption are efficient. Government agencies and responsible consumers play an active role ensuring correct system long-term operation” (Nobre & Tavares, 2021).

If condensing this definition, the primary ambition and purpose of the CE are to “decouple economic activity from the consumption of finite resources”, as defined by the Ellen MacArthur Foundation⁶. However, looking at the definition, it becomes evident how multi-faceted the CE agenda is as an entire economic system. Researchers have defined an array of circular strategies, or principles, that, on a high level, suggest ways of achieving this decoupling. Bocken et al. (2016) synthesise, building on previous research, the linear and circular strategies for reducing resource use. This notion is extended by Konietzko et al. (2020), who add two strategies – one of which adds the use of data to the toolbox for achieving CE. Figure 1.1 presents the visual representation of the two syntheses of the strategies; figure 1.1(a) presents Bocken et al. (2016) while figure 1.1(b) presents Konietzko et al. (2020). The five strategies are: narrowing, slowing, closing, regenerating, and informing. Narrowing refers to using fewer resources during a product’s different life cycle stages. Slowing refers to using resources for a more extended period. Closing refers to returning used resources to a state where they can be reused. Regenerating refers to sustaining natural ecosystems. Finally, inform refers to using information technology data to support the other four strategies (Konietzko et al., 2020).

⁶ <https://ellenmacarthurfoundation.org/topics/circular-economy-introduction/overview>

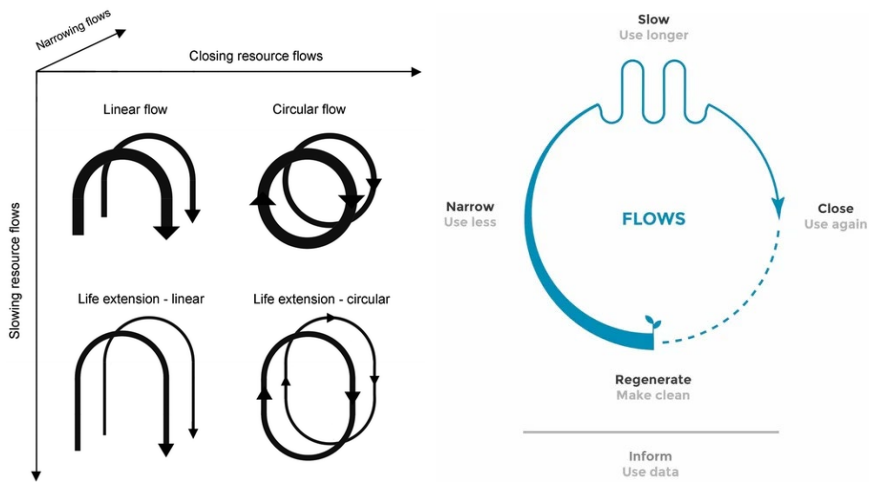

Figure 1.1 Strategies for reducing resource flows. (a) (Bocken et al., 2016) (b) (Konietzko et al., 2020)

The CE applies to three economic levels: the macro-, the meso-, and the micro level, as referred to in the definition by Nobre & Tavares (2021). The macro level concern national and transnational elements such as legislation for developing recycling-oriented societies. The meso level concern industry and supply chain-specific elements such as infrastructure and knowledge institutions. The micro level concerns the corporate elements, including its business model, operating model, and consumer level (Merli et al., 2018). These three levels vary in the level of control the manager has in designing the optimal circular system for their organisation, as presented in Figure 1.2. The manager has the most control in the corporate elements of the micro level while they have limited control at the meso level – depending on their level of power in the eco-industrial network, and no control at the macro level. Hence, the manager must understand the dynamics of the macro and meso elements in their design of the micro elements to assure coherence – thereby avoiding a lack of goal congruence – across the economic levels.

From the organisational perspective, the CE and its transformation is a multi-faceted endeavour that requires adopting a systems perspective to avoid the pitfalls of sub-optimisation. This is apparent in the academic discourse, as seen in the multitude of papers focusing on the barriers to (e.g. Ayati et al., 2022), the business models of (e.g. Pieroni et al., 2019), and the transformation models such as maturity models for (e.g. Pigosso & McAlone, 2021) the CE transformation. To exemplify this, Urbinati et al. (2021) identify both enablers and barriers affecting the design of circular business models across all three economic levels. At the macro level, legislation and resource scarcity are argued to nudge the development of circular business models.

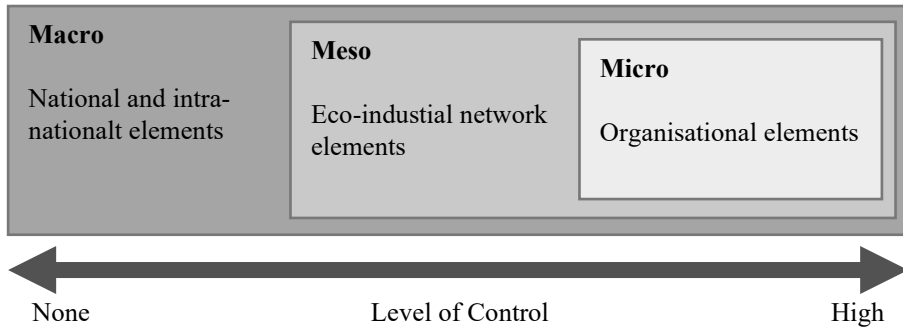

Figure 1.2 Level of control for micro, meso, and macro economic levels. Inspired by (Uhrenholt et al., 2022b)

At the meso level, the availability of supply chain partners, the proximity of partners and customers, and the rate of market changes are affecting development. Finally, at the micro level, a broader range of technical, economic, and organisational factors enable and hinder development (Urbinati et al., 2021). To guide organisations in the transformation and overcome the identified barriers, the rise of maturity models, along with other assessment and transformation models, is evident in the context of CE. These models seek to define and structure the dimensions of the CE, whether focusing on fragments of the CE, e.g. product design (e.g. Berzi et al., 2016) or the organisational transformation (e.g. Sacco et al., 2021). Our work exemplifies this in our investigation and consolidation of the vast array of different CE dimensions, as presented in Table 1.1. Furthermore, our study argues that while the dimensions vary in formulation, their content is aligned (Uhrenholt et al., 2022b), which serves as a second example of the academic discourse for CE being in the pre-paradigmatic phase.

1.2. THE ROLE OF DIGITAL TECHNOLOGY

In parallel with the growing attention to CE, the presence of digital technologies in the industry is increasing. These technologies represent a new competitive lever that benefits manufacturing organisations in Western countries in countering the previous decade's efforts in outsourcing and offshoring manufacturing activities. As a result, within the European Union, the representation of manufacturing organisations in the gross domestic product dropped approximately 30% to reach a share of 15.4% in 2014 (Davies, 2015). This phenomenon was mobilised because of rising labour costs in western countries, which later caused a variety of disadvantages as operations became more rigid from the increased distance between manufacturing and research and development operations (Mykhaylenko et al., 2017). In turn, the European Union initiated, in 2008, a research project to identify the potential of information and communication technology as this new competitive lever (Davies, 2015), which later, in 2011, was coined 'Industrie 4.0' (I4.0) by the German researchers (Kagermann, 2015). The argued competitiveness enabled by adopting digital technologies comes

from various organisational value drivers. According to McKinsey, eight distinct drivers represent the new level of competitiveness for manufacturing organisations, from adopting I4.0 technologies (Figure 1.3) (Wee et al., 2015).

Table 1.1 Dimensions of the organisational CE (Uhrenholt et al., 2022b)

Dimensions	Definition
Value creation	The models utilised for generating and capturing value from CE activities (e.g., sales models, take-back programmes, life-extending services) and environmentally positive performance (e.g., resource and emissions savings and regeneration).
Governance	The strategies and plans for the circular transformation (e.g., resource allocation, circular awareness, and engagement on different hierarchical levels).
People and Skills	The mindset and skills (both internally and with external partners) required for enabling and acting on the circular transformation (e.g., circular competencies, learning, and training culture).
Supply Chain and Partnership	The stakeholders external to the organisation required for the exchange and optimisation of materials, products, and activities (e.g., shared visions and activities, engagement with external experts).
Operations and Technology	The equipment and systems in place for performing CE activities (e.g., machinery and tools, systems aiding the scheduling and identification of appropriate treatment according to value potential).
Product and Material	The characteristics of the products that enable circular strategies and activities (e.g., extended life cycle, simple disassembly, and refurbishment).

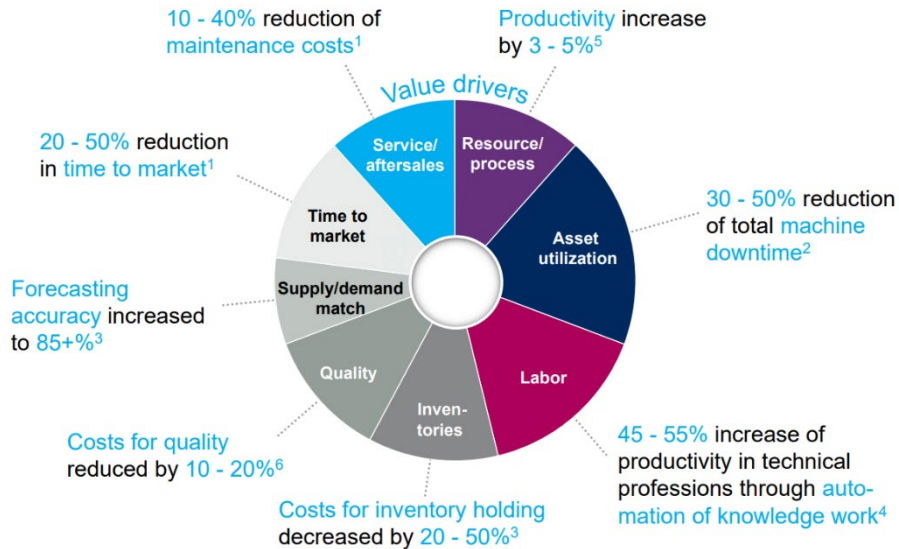

Figure 1.3 I4.0 value drivers (Wee et al., 2015)

1.2.1. THE ENABLING TECHNOLOGIES

The primary enabler for achieving the value drivers of I4.0 is enabling digital technologies. These technologies are a mix of new and existing technologies that all contribute to automating and integrating manufacturing and its supporting processes. The existing technologies are highlighted in this agenda, as their computing power is improving while the cost is decreasing to the degree that commoditises these technologies – This phenomenon is known as Moore’s Law (Moore, 1998). The enabling technologies are: Additive manufacturing, Augmented and virtual reality, Autonomous robots, Big data and analytics, Cloud computing, Cybersecurity, Internet of things (IoT), Simulation, and Systems integration.

While each technology brings forward its value proposition that justifies its presence in the industry, the absolute value – and the primary argument of I4.0 – emerges from the combined and connected utilisation of multiple of these technologies (Rüßmann et al., 2015). This integrated use of digital technologies provides transparency in the collection, availability, and processing of data across operational activities that, from a business perspective, allow managers to transform data into context-specific information for supporting decision-making (Wu et al., 2016). The information also provides a foundation for organisational learning to ensure productivity and competitiveness (Bernstein, 2012). This learning enables organisations to develop new organisational forms and business models that address short-term performance improvements and societal and environmental concerns. Hence, the use of digital technologies can enable the generation of profit and impact simultaneously (Li, F., 2020).

1.2.2. THE INTERNET OF THINGS

The common denominator of I4.0 is the need to generate data from physical objects that can communicate with each other and digital objects. This puts the IoT, a network of sensors for generating and transmitting data among objects, in the middle of the agenda as a catalyst for digital transformation (Cohen et al., 2019).

The concept of IoT originated in 1999 when it was referred to as “uniquely identifiable interoperable connected objects with radio-frequency identification technology (RFID)” (Li, S. et al., 2015). At this stage of development, the technology-enabled passive identification of objects in a wireless network was increasingly adopted in different industries, such as logistics and pharmaceutical manufacturing. Since then, the concept has evolved through the phases of representing wireless sensor networks, in which other sensor types than RFID were introduced, and the concept of smart things, in which mobile computing was introduced to the network is connected devices. The current phase represents the next generation in this network, in which intelligent physical objects can be identified and controlled digitally. Therefore, in its current stage, the IoT is referred to as a “technological paradigm” (Lu et al., 2018) as it represents an architecture in which sensors generate data from the physical environment, communication networks for transmitting the data between physical and digital entities, and gateway applications for processing (i.e. storing and analysing), and finally presenting the information to the user (Links, 2013).

The role of IoT in the CE is widely acknowledged in the academic discourse (e.g. Agyemang et al., 2019; Alamerew & Brissaud, 2020; Kristoffersen et al., 2020; Lieder & Rashid, 2016; Rajput & Singh, 2020; Rejeb et al., 2022; Singh, J. & Ordoñez, 2016). Among its capabilities, the IoT can monitor products throughout their lifecycle and support data-driven decision-making according to circular principles (Ingemarsdotter et al., 2019). In summary, the IoT can enable organisations in their circular transformation through increased transparency and control in supply chain operations and innovating their business models (Ramakrishna et al., 2020; Shokouhyar et al., 2019).

1.3. THE TWIN TRANSFORMATION

The European Commission has defined the following as one of their key strategic orientations: “Making Europe the first digitally-led circular, climate-neutral and sustainable economy through the transformation of its mobility, energy, construction and production systems” (European Commission, 2022b). Accordingly, the European Commission puts the ‘twin green and digital transition’ at the forefront of its growth strategy, the “European Green Deal“, to create competitive products, services, and business models through research and innovation (European Commission, 2022a). The twin transformation, or transition as the European Commission labels it, repre-

sents the coherent and simultaneous pursuit of the circular and the digital transformation, for which the two individual agendas mutually benefit each other. While the relation between the IoT and the CE – used as the working definition throughout this research project, rather than the entirety of the digital technologies – is well argued for in extant literature, it is done in a one-way relation. As seen in the previous sections, the role of digital technology plays an active yet secondary role in the CE transformation, e.g. as seen by its presence in the framework of CE strategies by Konietzko et al. (2020) and the CE dimensions as defined by Uhrenholt et al. (2022b). Meanwhile, the role of the CE in IoT development and implementation remains unexplored.

This dual agenda may be elaborated by explicitly distinguishing between the data requirements for capturing material and functional value. In their discussion of resource effectiveness in product value, the concept of material and functional value originates from Kumar et al. (2007). Product value can be divided into material value; the value associated with the raw materials used to manufacture a product, and functional value; the value associated with realising the product functionality (Kumar, V. et al., 2007). The environmental impact of perceiving material and functional value of products are significantly different. The emissions, resource consumption, and monetary cost of recycling and remanufacturing products are significantly higher than those of reuse and sharing strategies relative to the value capture of these strategies. However, the data requirements for capturing material value are different, i.e. more simple for capturing functional value. For capturing material value, product meta-data, i.e. the material and traceability data, is required, e.g. material content, the origin of the materials, rate of recycled materials in product and packaging, product design characteristics, and resources used in the manufacturing process. For capturing functional value, the product meta-data and product performance from the use phase is required, e.g. frequency of use, product damage/failure, rental frequency, and use environment (Bjerre & Parbo, 2021).

The IoT becomes relevant to generate and collecting the product performance data that allows for pursuing functional value in circular loops. By installing intelligent sensor technology to products, connecting these to the internet and performing live performance analysis, organisations can perform timely replacement or repair to products before irreversible damage occurs to the product or the system in which the product operates (Morlet et al., 2016). The IoT technology generates a direct link between the product in the market and the organisation managing it during its use phase. The application of data analytics (Gartner, 2022), e.g. diagnostic or prescriptive analytics, to the product performance data can build condition-based or predictive maintenance operations, i.e. enabling the execution of maintenance activities that maintain the steady performance of assets, through demand-driven forecasts (Scheffer & Girdhar, 2004).

The supply chain plays an increasingly important role to the individual organisation, as the increasing complexity of both products and processes makes it too challenging

to manage all that know-how in-house (Fine & Whitney, 2002). With this increased value creation in the supply chain, increased value loss and leakages follow. Therefore, a shift in mindset is required from the traditional value chain versus the value chain to the more extensive value system of supply networks. The exchange of waste and by-products between otherwise unrelated organisations, i.e. Industrial symbiosis, is a well-known concept in the industry. However, it is primarily adopted by physically proximate organisations due to the benefits of infrastructure, knowledge, and trust relative to building such relations with physically distant organisations (Ramshewa et al., 2019). These activities have recently been supported by establishing digital platforms and intelligent sorting (Prosman & Wæhrens, 2019). If extending the view in this trajectory, intelligent technologies can optimise waste and byproducts at the value system level while enabling sharing, leasing, and performance business models at the individual organisation level (Tukker, 2004).

Table 1.2 Correlation between I4.0 value drivers and CE strategies

I4.0 Value Drivers	CE Strategies
Productivity Increase	Narrow
Machine downtime decrease	Slow, Close
Automation of knowledge work	All
Inventory holding decrease	Narrow
Cost of quality decrease	Narrow, Slow
Forecasting accuracy increase	Narrow, Close
Time to market decrease	Narrow, Close
Maintenance cost decrease	Slow

Beyond the scope of maximising the value capture of products and resources, the presence of material and product performance data is valuable in many other organisational activities. For example, the detailed understanding of resource flows, process limits and precise tolerances enable more precise scheduling and planning on both operational, tactical, and strategic levels (e.g. sales and operations planning), which, in turn, increases the utilisation of assets, i.e. reducing waste in terms of overprocessing and idling. The ambition of the twin transformation is for this optimised planning of activities to be achieved at the product or organisational level and a value

systems level, i.e. the direct and indirect supply chain to the individual organisation. By generating, processing, and sharing data across value systems, autonomous decision-making in the supply chain will optimise the resource flows and utilisation, e.g. by changing and altering the speed of flows from anticipating breakdowns and damage of critical components. To summarise, Table 1.2 displays linkages between the CE and the I4.0 agendas by correlating the I4.0 value drivers and the CE strategies presented in Sections 1.1 and 1.2.

1.4. MANAGING THE TRANSFORMATION

This dual focus agenda is gaining attention both in industry and academia. For example, the European HORIZON programme prioritises research activities in this agenda, with the expectation of "building a lasting and prosperous growth, in line with the EU's new growth strategy, the European Green Deal" (European Commission, 2022). Accenture argues that organisations pursuing the twin transformation are "2.5 times more likely to be among tomorrow's leaders" (Ollagnier et al., 2020). While this argument may be questionable, the twin transformation appears more often in the industry. In major European organisations, the conjunct discussion of digital technology and sustainability appears in 5% of earning calls in 2020, increasing from 2% in 2018. In comparison, digital technology and sustainability are discussed individually in approximately 50% of earning calls in 2020 (Ollagnier et al., 2020). Furthermore, 35-40% of the surveyed European organisations plan to invest in digital technologies, while 35% point towards IoT as the primary technology for their investments (Ollagnier et al., 2020).

Despite the increasing attention to the twin transformation (even more so for the two agendas individually), the task of engaging and succeeding in an organisational transformation is proven troublesome to organisations. For example, McKinsey has found that few organisations (20% in 2016) embarking on transformations are experiencing substantial and sustained performance improvements, while even fewer (16% in 2018) organisations are succeeding in complex and multi-faceted transformations such as the digital transformation (de la Boutetière et al., 2018). Lassen & Waehrens (2021) also find that organisations adopt an operational perspective in implementing digital technologies while neglecting the tactical and strategic potentials. Subsequently, Colli et al. (2021a) argue that organisations should recognize the applicability of learnings combined with the temporal dimension in their engagement with digital technologies.

The challenge of succeeding in an organisational transformation can be described through Martec's Law, which is portrayed as the "greatest management challenge of the 21st century" (Brinker, 2013). Martec's Law argues that while technological development is exponential (also known as Moore's Law), organisational development is happening at a logarithmic rate, creating an ever-growing gap between the two. Consequently, to overcome the overwhelming technological development, management must strategically prioritise which technological development paths to embrace

while explicitly working with the organisational systems' learning capabilities to absorb the new technological developments and capture value from these accordingly. Additional concepts such as the hype curve (Fenn & Time, 2007), the Dunning-Kruger effect (Dunning, 2011), and the performance dip (Elrod & Tippett, 2002) contribute to Martec's Law by elaborating how technologies develop while their adaptation happens at a slower rate.

From the CE perspective, the manufacturing organisations are aware of the agenda, while their engagement is predominantly characterised by adopting an internal focus and targeting stand-alone changes that make an impact without challenging the surrounding operations design (ATV, 2022). Using recycled materials and designing products according to their life cycle are the most adopted circular processes, while the more systemic processes, such as product take-back and a product-as-a-service, are the least adopted circular processes. The operational and technological barriers are the highest for manufacturers, while they predominantly find that the available technologies in the market are sufficient for realising the circular transformation (ATV, 2022). According to the CE maturity reference model we developed in the appended paper 3, the manufacturers are at the 'basic' and 'explorative' maturity levels. At these levels, the need for adopting CE principles appears sporadically, few CE principles already generate value, although unintentionally, and explorative activities are taking place to uncover the contextual value of the CE strategies. This further means that they are yet to face the inflexion point in which their engagement in the twin transformation will substantially challenge the design of their existing operations and become the new foundation of their business (He & Wong, 2004; Uhrenholt et al., 2022b).

If we try to summarise the current state of development of the twin transformation presented in this chapter, we can see that (1) The potentials of the twin transformation agenda are well-established. The principles and strategies of the CE and the IoT are well-defined, despite the agendas being in pre-paradigmatic phases. (2) The industry is challenged in getting engaged in this agenda and even more so in succeeding in its transformation. The nature of multi-faceted transformations such as the CE, I4.0, and the twin transformation have a challenging track record, where few organisations build sustained performance improvements accordingly. (3) Martec's law, the hype curve, and the performance dip are all explanations as to why organisations are challenged in succeeding in such transformations – While suggesting specific action to be taken by organisations to navigate these agendas. (4) Organisations are constrained in navigating and keeping up with the development of these agendas, while they tend to adopt a short-term operational perspective in developing and implementing new technologies and organisational principles. Additionally, if we turn to recent literature, we find the following gaps in supporting the industrial circular and digital transformation:

- The lack of frameworks to guide the digital (Büyükoçkan & Göçer, 2018) and circular (Nobre & Tavares, 2021) transformation.

- The lack of knowledge concerning how to address technical and processual barriers, e.g. how to design processes according to CE principles using digital technologies (Abdul-Hamid et al., 2020).
- The lack of knowledge concerning the financial feasibility of CE initiatives, e.g. product take-back (Abdul-Hamid et al., 2020; Sepúlveda-Rojas & Benitez-Fuentes, 2016).

1.5. THESIS OBJECTIVES

According to the gaps identified in the extant operations management literature concerning the circular and digital transformation, this dissertation, including the collection of papers appended herein, intends to facilitate a deeper and more nuanced understanding of the twin transformation by providing:

An understanding of the structural elements of the twin transformation and how they can be utilised to drive the transformation to build competitive advantage in the changing industrial context.

Frameworks and guidelines for supporting the successful engagement with the twin transformation.

1.6. THESIS STRUCTURE

The thesis is divided into nine chapters, which compose the collection of papers appended to it in unison. The thesis discusses the research project more broadly than the individual appended papers.

Initially, in chapter 1, the CE agenda is introduced, including its definitions, strategies, and economic levels for which the agenda is relevant. Subsequently, the role of digital technologies and their dual relationship with the CE agenda is presented, followed by the challenges perceived in managing the circular and digital transformation.

Chapter 2 presents the research context in which the research activities are performed. This presentation included the Innovation Factory North and its engagement ecosystem, bringing together researchers, industrial cases, and technology experts in these desired research activities.

Chapter 3 presents the research design that frames the activities accordingly. Here the philosophical position and the methodological framework deployed throughout the research project are presented – in which the issue of balancing practical and academic relevance is explicitly emphasised.

Chapter 4 provides a summary of the appended research papers that comprise the foundation of this thesis. Additionally, the linkages between the individual research papers are briefly presented in this chapter.

Chapter 5 presents the research findings of the first research phase, focusing on the current level of engagement in the twin transformation agenda in the Danish manufacturing industry.

Chapter 6 presents the research findings of the second research phase, focusing on enabling the manufacturing industry to design their contextual engagement in the CE transformation.

Chapter 7 presents the research findings of the third research phase, focusing on how manufacturers can work with IoT to unlock and generate value according to CE principles.

Chapter 8 discusses the thesis, emphasising the academic and managerial contributions.

Chapter 9 concludes the thesis by highlighting the value of the research activities and outcomes, the limitations experienced throughout, and the opportunities for future research to extend this research domain further.

CHAPTER 2. RESEARCH CONTEXT

This research project is conducted as a combination of desk research and applied research in collaboration with the industry. Therefore, this chapter presents the industrial context in which the research is conducted.

The research project is sponsored by the Innovation Factory North⁷ (IFN), which is funded by the European Regional Funds. The IFN project aims to improve SMEs' competitiveness by implementing I4.0 technologies, i.e. making them 'smarter'. The IFN is a local eco-system hub of industrial companies, technology providers, knowledge institutions, and its students. The IFN defines an iterative and collaborative approach for developing and implementing I4.0 technologies in Northern Jutland, Denmark. The IFN eco-system and its approach are grounded in the following three hypotheses concerning exploration in fast innovation cycles, prototyping, and learning from incremental steps (Møller et al., 2022a):

- The innovation process: The technologies are available in the market. The task is identifying and matching the required competencies to the needs and problems.
- Organising the development process: Digital solutions can be made through co-location, i.e. putting relevant stakeholders in the same room and co-creation, i.e. collaboration between industrial manufacturers and technology providers.
- The learning process: Knowledge and competencies can be built in an iterative and experimental process that can be structured and facilitated by researchers.

2.1. RESEARCH ECO-SYSTEM

The research eco-system is comprised of four distinct domains, as visualized in Figure 2.1: The academic domain where the research and the engagements in the eco-system are designed; the industry domain that represents the industrial companies engaged in the eco-system through the representative managers; the technological domain that represents the technology providers and the insights they bring; and the joint engagement domain that represents the actual engagement between the involved parties in the fashion that the researchers have designed.

⁷ <https://www.ifn.aau.dk/>

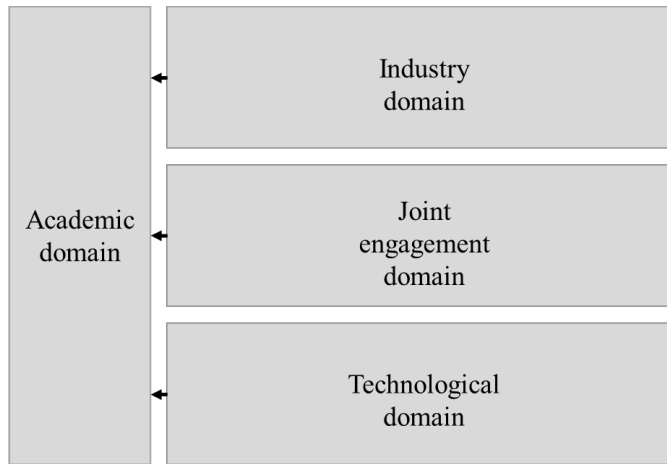

Figure 2.1 Conceptualisation of the research eco-system (Inspired by (Møller et al., 2022b))

In this eco-system, the different stakeholders adopt specific roles and gain certain benefits while inducing certain constraints, as presented in Table 2.1.

Table 2.1 IFN stakeholders

Stakeholder	Primary Role	Benefits	Constraints
Industrial companies	Problem owner	Innovation capabilities and new knowledge	Hours to participate, develop, and implement the solutions
Technology providers	Solution owner	Prototyping and testing specific solutions based on own technology	Hours to participate and implement the solutions
Researchers	Process owner	Testing research propositions by engaging with the problem.	Specific research interest and focus

The four groups of industrial cases, or stakeholders, that engaged in the research activities were selected based on their relevance and interest in the research questions, as presented in Table 2.2. Hence, these cases were selected according to the purposive (also known as judgemental) sampling technique, as these provided a setting that allowed collecting the desired empirical information (Taherdoost, 2016). Furthermore,

the industrial cases have been considered suitable for their respective engagement in this research project, based on their availability to dedicate resources to its activities and their agreement to follow the engagement as designed by the researcher.

Table 2.2 Contribution of industrial cases

Contribution/need	Case A	Case B	Case C	Case D
Understanding the engagement and barriers to Twin transformation	X	X		X
Understanding CE from the organisational perspective and proposing frameworks for designing, implementing, and maturing		X		
Understand how to explore and exploit IoT for CE			X	X

2.1.1. DANISH MANUFACTURING ORGANISATIONS – CASES A AND D

Cases A and D represent two groups of manufacturers that engaged in the twin transformation agenda. Both the A and D companies were engaged in the multiple case study article appended in the thesis as paper 2. Case D companies are those engaged in exploring IoT technology for improved competitiveness – one of which is reported in appended paper 5. These cases' early-stage engagement with the twin transformation was a common denominator. This level of maturity gave the industrial cases a natural emphasis on learning the value and potential to build maturity in these agendas – and in doing so, their attention transferred from one agenda to the other in the realisation of the dual relation between CE and I4.0. In their engagement with these agendas, the manufacturers predominantly took an operational approach in which they initiated a short-term project with a limited organisational or technical scope for which they emphasised building knowledge concerning the agenda while gaining performance improvements from the project's specificity. In other words, they engaged in these projects according to the hypothesis of the eco-system. Accordingly, the differing industrial outlets meant that these contributed to investigating the thesis objectives differently or contributed to a confined part of the objectives.

2.1.2. DANISH LARGE ORGANISATION – CASE B

Case B is a large Danish manufacturing organisation. This organisation is engaged in the early stages of CE transformation; hence, they are at a low circular maturity level.

While they still execute explorative demonstration projects, they do so with a greater strategy – making each demonstration project a small step on a more extensive and structured journey. Therefore, this industrial case proved more suitable for the second phase of the research project, relative to the others, concerning the CE transformation process and the development of a framework for guiding this transformation.

2.1.3. RESEARCH AND TECHNOLOGY ORGANISATION – CASE C

Case C represents a Danish Research and Technology Organisation (RTO). This RTO engaged in the research project as the technology provider, representing the technological domain in the research eco-system (Figure 2.1). The RTO engaged in the research project with a dual focus. First, to engage with Danish SMEs embarking on the I4.0 transformation, providing insights and IoT-based solutions. Second, the RTO sought to develop their product catalogue, being services to provide Danish manufacturers for which the CE agenda was to make its appearance. Finally, the RTO engaged in the third phase of the research project to demonstrate the explorative framework for idiosyncratic IoT-based solutions, during which they brought forward their technological expertise towards the industrial cases. It is worth mentioning that the RTO engaged with the industrial cases in close collaboration with the researcher, meaning that only primary data was generated from these engagements.

CHAPTER 3. RESEARCH DESIGN

The industry has consistently been concerned with transformation to elevate performance and ensure competitiveness (e.g. division of labour, lean, or outsourcing). However, the scope of transformations has changed from cost (the 1960s) and quality (the 1970s) to innovation from the 1990s and onwards from the increasing innovation clock-speed (Boer, 2004). The operations management research domain has been concerned with these transformations and the required innovation, whether product, process or organisational (Boer & During, 2001). This concern is not less prevalent in the domain of twin transformation for enhancing industrial sustainability. This chapter presents how to answer the research objectives and the methods utilised to investigate this. The question calls for empirical research to understand the current level of circularity in the industry – to be used as an outset for developing guidance to the industry in developing additional CE capabilities. Additionally, conceptual research is needed to develop these guiding frameworks that enable the industry in its CE transformation. The chapter presents the research approach, the philosophical position, the framework guiding the research design to answer the research questions, and the methods used to answer the research questions.

3.1. PHILOSOPHICAL RESEARCH POSITION

The philosophical research position represents the author's view on the world concerning what constitutes knowledge and truth and whether truth is perceived as being objective or subjective. Several philosophical views are established in the continuum, from positivism on one end to constructivism on the other. The positivist sees the world as external to the individual, meaning that facts can be observed from reliable and replicable methods, which makes knowledge generalisable. Truth is an objective product of pure reasoning (Bell et al., 2022). Conversely, the constructivist sees the world as socially constructed, dependent on the circumstances, actors, and researchers that all influence truth subjectively (Croom, 2010).

To discuss the philosophical position taken in this research project, it is beneficial to consider the nature of the research field I am navigating. Operations Management is a two-fold research domain, balancing the ‘hardcore’ engineering domain and the ‘soft’ social sciences from the close engagement with people in the organisational context (Van Aken et al., 2016). This duality of Operations Management research increases the complexity of research activities due to the increasing number of variables to consider, which may not be apparent to, or in control by, the researcher on account of bound rationality. Therefore, the adoption of a pure positivistic or constructive philosophical position is deemed naive in this context, as the researcher, on the one hand, is not able to propose universal generalisations from the acknowledgement of contextual and uncontrolled variables, while on the other hand, rejecting any form of generalisability drifts too far from the engineering domain.

The Operations Management research domain is characterised by its dealing with practical problems, and hence, it is characterised by its applied nature (Boer et al., 2015; Holmström et al., 2009). The domain, and its contributors, aim to engage with industry with the dual purpose of creating knowledge while solving practical problems in the process (Lewis, 1998; McCutcheon & Meredith, 1993). Theoretical contributions in this domain consist “of [developing] a better predictive framework, model, or theoretical tool that helps solve an empirical problem even if the framework incorporates wildly inaccurate representations of reality” (Boer et al., 2015). Accordingly, the philosophical stance in this research is one of the instrumentalist (also known as the pragmatist) (Laudan, 1978). As reality, i.e. the industrial context, changes over time, the Operations Management research domain does not progress towards a universal optimum, or truth, if you will. Alternatively, theories are strongly linked to their times and are developed to meet the industrial demands of solving problems experienced now and in the future.

3.1.1. BALANCING PRACTICAL AND ACADEMIC RELEVANCE

The emphasis on solving practical problems while contributing to academic knowledge is discussed in extant literature (Boer et al., 2015; Nicolai & Seidl, 2010; Stentoft & Rajkumar, 2018; Toffel, 2016). Among these studies, Toffel (2016) argues that for research to be relevant, it must enable managers to make improved decisions. This can be done in a wide array of ways, as defined by (Nicolai & Seidl, 2010) in their terminology containing eight different forms of practical relevance, as depicted in Figure 3.1.

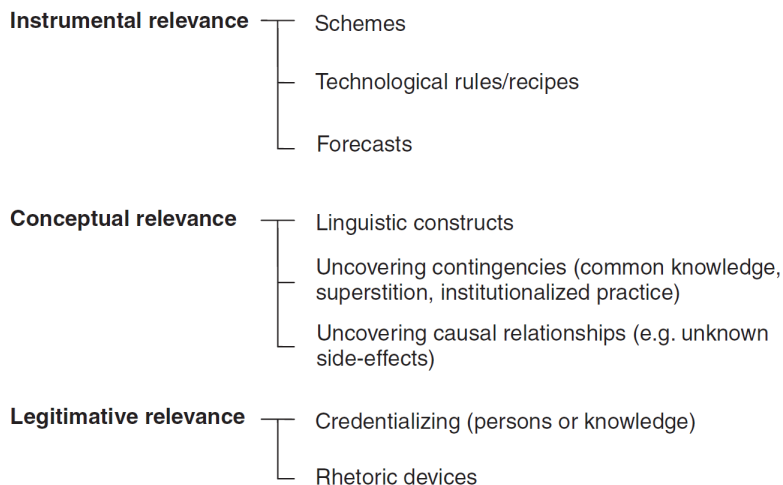

Figure 3.1 Terminology for practical relevance (Nicolai & Seidl, 2010)

Practical relevance is distinguished into three types of relevance. First, *instrumental relevance* includes systematic and precise information, or rules, that allow the manager to categorise different decision situations. This information is predominantly presented graphically as decision trees or charts. Instrumental relevance takes shape as schemes, technological rules and recipes, and forecasts. Second, *conceptual relevance*, which includes concepts, metaphors, and new or alternative routes of action, does not determine a specific course of action. Instead, it enlightens the manager on how to perceive a decision. Conceptual relevance takes shape as linguistic constructs, uncovering contingencies and uncovering causal relationships. Third, *legitimative relevance* is a latent form of relevance in the shape of credentialing and rhetoric devices. This type of relevance appears like the one of linguistic relevance. However, it serves a different purpose – creating legitimacy in the managers' argument using rhetoric (or linguistic) devices.

During this research project, I predominantly contribute to instrumental relevance in developing schemes (i.e. frameworks) for guiding the managers' decision-making. I also contribute conceptual relevance in identifying variables for the circular economy transformation and IoT while latently contributing to legitimative relevance by providing rhetoric devices to the manager. To achieve practical relevance in this research project, I have engaged actively in the industry with various case companies to get hands-on experience of the research domain in practice, as already elaborated in Chapter 2. This engagement has ensured that the emphasis on balancing academic and practical relevance could be achieved by aligning the gaps identified in academic literature with the gaps identified in practice (Toffel, 2016).

Additionally, developing theoretical contributions can be either *consensus-creating* or *consensus-shifting*. By creating consensus, the contribution provides novel insight into the relationship between variables while shifting consensus concerns moving an already accepted position in academia to another (Boer et al., 2015). The academic contributions in this research project are all consensus-creating, as they seek to answer previously unanswered questions. For example, by creating an overview of the factors affecting the financial performance of a product take-back system or by combining the existing approaches of value stream mapping, goal-question-measure, and task-technology fit in a novel framework for exploring the idiosyncratic design of IoT-based solutions.

3.2. RESEARCH FRAMEWORK

This section introduces the research framework and the relation between the appended papers. A total of six papers are appended to this research project, each aiming at contributing to one or more of the defined research phases. The clustering and relation between the appended papers are presented in Figure 3.2. The remainder of this sec-

tion elaborates on these relations between the papers and their research questions. Finally, the research methods utilised in conducting this research are elaborated in Section 3.3.

The first phase of the research project concerns the current level of twin transformation among Danish Manufacturers, along with the barriers experienced in progressing further in the CE transformation. Two studies, and hence papers, address this objective: A multiple case study and a single case study. In this phase, the conceptual relevance is present in uncovering causal relationships between variables relevant to the CE transformation and the use of IoT herein – which changes the understanding of the decision situation managers face.

The second phase focuses on the CE transformation in manufacturing organisations, including the dimensions and factors to consider and how to engage in the transformation. Three studies address this objective: A case study, a conceptual model development, and a systematic literature review. In this phase, both conceptual and instrumental relevance is present. New linguistic concepts are developed and structured in schemes for changing how managers communicate and make decisions in CE transformation.

The third phase focus on the exploration and exploitation of IoT technology in the CE transformation. Two studies address this objective, both of which deploy design science research. This phase provides instrumental relevance as both studies design frameworks for exploring and exploiting this technology. During this research project, another seven publications have been co-authored. These are not part of the PhD thesis and its objectives; however, some are used throughout the thesis. The publications are listed here:

- Ayati, S.M., Nygaard, J., Waehrens, B.V. (2020). A decision model for re-engaging End-of-life products into the forward supply chain. *NOFOMA 2020*, Virtual, Reykjavik, Iceland.
- Jensen, S. F., Uhrenholt, J. N., Rincón, M. C., Adamsen, S., Kristensen, J. H., & Waehrens, B. V. (2022). Remanufacture of warranty returns as experimental outsets towards product takeback. *NOFOMA 2022*, Reykjavik, Iceland.
- Rincón, M. C., Jensen, S. F., Adamsen, S., Uhrenholt, J. N., Kristensen, J. H., & Waehrens, B. V. (2022). WHAT TO TAKE BACK? Decision-making factors for functional value product exploitation. *NOFOMA 2022*, Reykjavik, Iceland.
- Adamsen, S., Rincón, M. C., Uhrenholt, J. N., Jensen, S. F., Kristensen, J. H., & Waehrens, B. V. (2022). THE STRUCTURAL ELEMENTS OF A GREEN SUPPLIER COLLABORATION PROGRAM. *NOFOMA 2022*, Reykjavik, Iceland.

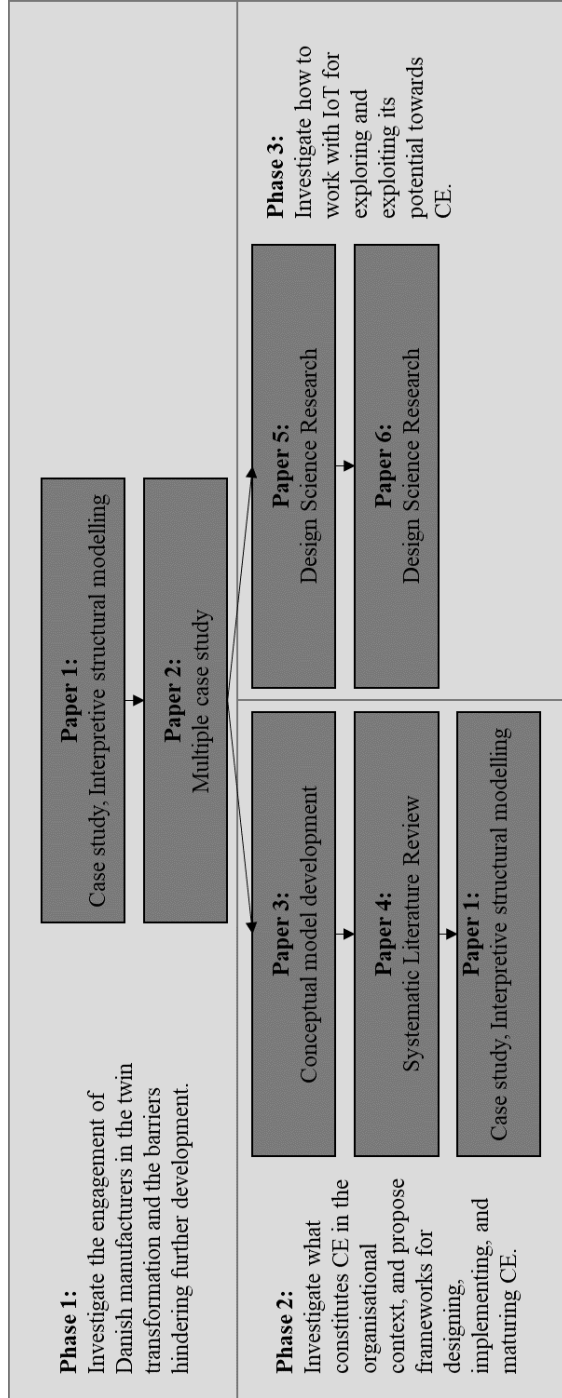

Figure 3.2 Research framework

- Jensen, S. F., Uhrenholt, J. N., Rincón, M. C., Adamsen, S., Kristensen, J. H., & Waehrens, B. V. (2022). An interpretive structural modelling of barriers towards product take-back. *9th EurOMA Sustainable Operations and Supply Chains Forum*, Zagreb, Croatia.
- Møller, C., Hansen, A., K., Palade, D., Sørensen, D., G., H., Hansen, E., B., Uhrenholt, J., N., & Larsen, M., S., S. (2022). Innovation Factory North - An Approach to Make Small and Medium Sized Manufacturing Companies Smarter. In *The Future of Smart Production for SMEs*, Springer (In Press)
- Møller, C., Hansen, A., K., Palade, D., Sørensen, D., G., H., Hansen, E., B., Uhrenholt, J., N., & Larsen, M., S., S. (2022). An Action Design Research Approach to study Digital Transformation in SME. In *The Future of Smart Production for SMEs*, Springer (In Press)

3.3. RESEARCH METHOD

The research approach and the methods chosen to investigate the topic in question are guided by the nature and current state of maturity of the topic as a research domain. The CE and the I4.0 agendas, and in turn also the twin transformation agenda, are all argued to be multi-faceted and hence must be researched from different perspectives, e.g. by distinguishing between micro, meso and macro economic levels or deep diving into technological versus managerial/governance oriented studies. Furthermore, the research agenda is in a pre-paradigmatic state, which still adopts concepts from other research domains and lacks empirically grounded studies (Pagoropoulos et al., 2017).

Therefore, to build a comprehensive understanding of the agenda – and hence, provide guiding frameworks accordingly- adopting a variety of research methodologies is beneficial. This led to the adoption of mixed methods as the primary methodological approach for this thesis.

3.3.1. MIXED METHODS

The mixed methods methodology is an umbrella term covering the versatile combining, integrating, and employing of multiple methods (Creswell et al., 2003). An academic consensus is that mixing different research methods can strengthen a study (Greene & Caracelli, 1997). However, all research methods have certain limitations. Thus, using mixed methods can eliminate or neutralize the drawbacks of the particular methodology (e.g. the level of detail of qualitative data provides other insights than the width achieved in quantitative data) (Jick, 1979). The mixed methods methodology consists of different types of mixing methodology. First, there is the mixing of methods, i.e. the ways of collecting and analysing data. Second, there is the mixing of methodologies, i.e. the different perspectives of how the entire research process is viewed. Third, there is the mixing of paradigms, i.e. the fundamental standpoint on truth and how to study it (Karlsson, 2010). In this research project, the primary mixing consists of mixing methodologies, while the methods used in individual studies and

my fundamental standpoint remain static. Mixing methodologies allow for answering different research questions, in which emphasis can be put on either generating overview of a phenomenon or gaining depth in understanding the mechanisms that determine specific actions in a phenomenon. In this research project, a combination of different research methodologies is utilised to answer different research questions, generate a broader understanding of the phenomenon in question, and develop instruments for practitioners in addressing said phenomenon, according to my philosophical research position. Thereby, the emphasis is both on generating explanatory knowledge by describing the current state of the investigated perspective, detached from the researcher, while subsequently generating instrumental knowledge, i.e. the application of knowledge for supporting the design and engagement in the CE (Pelz, 1978; Van Aken et al., 2016).

Framing this research project according to the mixed method principles can be deducted from the motivations for this study, as presented in Section 1.5. The emerging presence of the agenda, both at the EU level and the organisational level, combined with the previous insights into the challenges organisations are experiencing when pursuing either the circular or the digital agenda, calls for studies from varying perspectives. First, to enable the instrumental guidance of organisations, it is beneficial to obtain a broader understanding of the organisational population concerning its current engagement in the agenda, along with building a more in-depth understanding of how organisations perceive the role between the IoT and the circular principles. Second, following the philosophical stance, the emphasis is on understanding how to guide organisations in engaging in the transformation, both from the systems perspective encapsulating the agenda at the organisational level and by deep diving into more processual perspectives of contextualising barriers and exploring the potential of the IoT technology.

Considering the academic maturity level of the research domain, the following points are worth mentioning. First, the multi-faceted nature of the twin transformation agenda calls for approaching the research from multiple varying perspectives. The ambition to provide instrumental guidance to practitioners implies a need for adopting the systems perspective to enable the provision of more coherent insights into the agenda. As organisations must acknowledge contextual contingencies, some of which are external to their individual operations, the guidance to enable these organisations to transform must be designed accordingly. Second, the pre-paradigmatic nature of the agenda results in a lack of consensus about its subject matter, e.g. definitions, for which the question of how to approach the agenda suffers. Accordingly, the varying approaches utilised in the mixed methods are beneficial in seeking consensus across differing levels of analysis.

In summary, Table 3.1 provides an overview of the research activities conducted throughout this project. The table emphasises the methodologies adopted in the appended papers, their methods, and highlighting the contributions enabled by the methodological choices.

Table 3.1 Methodological choices for the six appended papers

Research Phase Purpose	Methodology in papers	Method	Methodological contribution
Understand the current engagement in the twin transformation agenda	Single case study	Interpretive structural modelling	In-depth understanding of the barriers faced in one case and the relevance of the method
	Multiple case study	Theory building, few focused cases	In-depth understanding of synergetic relationship between IoT and CE
Understand and instrument the design of the CE transformation	Conceptual model development	Conceptual model development	Suggests what constitutes CE maturity through the identification of dimensions and levels
	Systematic literature review	Systematic review technique. The five-step method by (Denyer & Tranfield, 2009)	In-depth understanding of the factors affecting the financial performance of product take-back
Instrumenting the exploration and exploitation of IoT in CE	Design Science Research	Solution incubation and refinement	In-depth understanding of how to explore the potential of IoT in existing operations
	Design Science Research	Solution incubation	Suggests how to use self-assessment to exploit existing IoT capabilities

CHAPTER 4. RESEARCH SUMMARY

This thesis is a collection of appended papers. This chapter presents a summary of each appended paper in Table 4.1, including its research question or objective, its method, and its linkages to the other appended papers.

Table 4.1 Summary of the six appended papers

<p>Paper 1: Unlocking barriers to circular economy: An ISM-based approach to contextualising dependencies (Jensen et al., 2022)</p>
<p>Research Question:</p> <p>“How can interpretive structural modelling be used as an approach to contextualize barrier interdependencies toward a circular economy?”</p>
<p>Method: Case Study – Interpretive Structural Modelling</p>
<p>Summary:</p> <p>The research uses an interpretive structural model to explore the mutual dependencies among barriers to CE transformation. The study finds the method valuable in identifying chain mechanisms among the identified barriers and, hence, identifying root causes inhibiting further development in CE transformation</p>
<p>Linkages:</p> <ul style="list-style-type: none">• Paper 2: The barriers identified in the one case study are coherent with the barriers and concerns addressed across the multiple case study.• Paper 3: The barriers identified in this paper suggest a low CE maturity, as these correspond to the low maturity levels. Furthermore, paper 3 suggests a method for creating transparency, a coherent understanding, and enabling further progression of CE maturity.• Paper 4: Barriers identified concern, among others, the financial/market conditions of a potential product take-back system.• Paper 5: Demonstration projects are scarce and can be deduced as hampering all identified barriers. In discussing the twin transformation, paper 5 proposes a framework enabling the demonstration of this novel technology in the context of CE.

Paper 2: Twin transformation: synergies between circular economy and internet of things – A study of Danish manufacturers (**Uhrenholt et al., 2022a**)

Research Question:

“How do synergies between IoT and CE enable manufacturers to engage with the twin transformation agenda?”

Method: Multiple Case Study

Summary:

This research uses a multiple case study to explore the synergetic relation between the IoT and CE as the two constituent constructs of the twin transformation agenda. The study finds the two constructs to be mutually beneficial, as IoT enables the generation of product use data for pursuing CE strategies, while IoT is elevated from the operational perspective when engaged in the CE context.

Linkages:

- **Paper 3:** The low CE maturity found in Danish manufacturers suggests the need for tools such as the proposed maturity model
- **Paper 4:** Financial sustainability is critical to the manufacturers while looping strategies, including product take-back, are not yet adopted. The lack of financial benefits of digital and sustainable investments is a show-stopper and a broadly identified barrier.
- **Paper 5:** Current level of maturity in Danish manufacturers calls for simple yet effective approaches for exploring the use of IoT to support the development of CE strategies.
- **Paper 6:** Like paper 5, with an emphasis on exploiting existing technologies available to the organisation that potentially are not utilised efficiently.

Paper 3: Maturity model as a driver for circular economy transformation (**Uhrenholt et al., 2022b**)

Research Objective:

“Identify organisational dimensions of the circular economy; identify circular economy maturity levels from the microeconomic perspective, and; propose, from a systems perspective, a maturity model for the circular transformation for the manufacturing organisation.”

Method: Conceptual Model Development**Summary:**

This research uses conceptual model development to propose a maturity model for the CE transformation of manufacturing organisations. The concept of maturity in CE is grounded in systems perspective and expertise principles. Organisational CE is defined into six organisational dimensions: value creation, governance, people and skills, supply chain and partnership, operations and technology, and product and material. Furthermore, the CE transformation is specified into six discrete maturity levels: none, basic, explorative, systematisation, integration, regeneration.

Linkages:

- **Paper 5 & 6:** The work with IoT (technology) is in low-mid maturity concerning in-use strategies due to its operational and topical nature. This is perceived as a steppingstone toward looping strategies which require, among others, historical data for appropriate decision-making.

Paper 4: Circular economy: Factors affecting the financial performance of product take-back systems (Uhrenholt et al., 2022c)**Research Question:**

“What factors affect the financial performance of product take-back, and how do they affect the financial performance?”

Method: Systematic Literature Review**Summary:**

The review finds 12 factors affecting the financial performance of product take-back systems. The factors are clustered into context, supply chain, and company. Two sub-dimensions are defined with the company dimension: product and operations. Finally, two propositions are put forward as to how to pursue the financial viability of product take-back: Designing take-back systems according to external and supply chain conditions and adopting innovative operating models such as digitalisation for breaking the trade-off between cost and value capture.

Linkages:

- **Paper 5:** The explorative framework proposes an opportunity to uncover the costs/benefits of using IoT in a product take-back system.

Paper 5: Translating transparency into value: an approach to design IoT solutions (Colli et al., 2021b)

Research Question:

“How can the process of designing an IoT solution be addressed in order to tailor it to context-specific application needs?”

Method: Design Science Research

Summary:

This research uses design science research to develop a framework for systematically addressing the idiosyncratic design of IoT solutions. The framework balances the exploration of new technology with exploitative needs to improve operating performance.

Linkages:

- **Paper 6:** The papers complement each other in overcoming pilot purgatory by emphasising exploring new technology and exploiting existing and available technology in the particular context.

Paper 6: A self-assessment framework for supporting continuous improvement through IoT integration (Nygaard et al., 2020)

Research Question:

“How can companies identify continuous improvement potential related to the integration of IoT?”

Method: Design Science Research

Summary:

This research uses design science research to propose a framework for systematically addressing the exploitation of existing IoT integrating technology in the individual organisation. The framework empowers the individual organisation by emphasising well-known methods for assessing its own operations and, hence, identifying the potential sub-optimal use of current technologies.

CHAPTER 5. TWIN TRANSFORMATION ENGAGEMENT OF DANISH MANUFACTURERS

This chapter investigates the current level of engagement in the twin transformation in the context of Danish manufacturing organisations. First, a case study of the barriers, and their contextual dependencies, experienced in a large Danish manufacturing organisation is presented. Second, a multiple case study is presented. This study investigates the current engagement in the twin transformation of Danish manufacturers and their approach to the transformation. The reflections made across these two studies inform the subsequent chapters in this thesis concerning how to design the transformation from a systems perspective and perform explorative and exploitative activities concerning the use of the IoT in the twin transformation agenda.

5.1. INTRODUCTION

The CE is gaining awareness in both the institutional and the industrial landscape. At the institutional level, both national and supra-national institutions are forming development strategies according to the CE principles, e.g. the European Union's Circular Economy Action Plan as part of the European Green Deal (European Commission, 2020) and China's Circular economy Promotion Law (Yuan et al., 2006). At the industrial level, despite increased awareness at the conceptual level, organisations are challenged in successfully adopting CE principles (Lahti et al., 2018). More specifically, manufacturing organisations in the United Kingdom and the European Union are found to have limited awareness of the CE agenda (Kumar, Vikas et al., 2019). As a result, recent research has focused on understanding the barriers that organisations experience in this agenda (e.g. Ayati et al., 2022), along with the ambition to define paradigms of the CE principles to steer the agenda out of its pre-paradigmatic phase (e.g. Nobre & Tavares, 2021). Accordingly, investigating barriers to the CE transformation is well-studied (Tan et al., 2022), leading to a nuanced understanding of these. The barriers to the CE exist at macro, meso, and micro-economic levels (Urbinati et al., 2021) and may be structured into the institutional, value chain, company, and employee level barriers (Guldmann & Huulgaard, 2020). Additionally, they are both hard and soft barriers (De Jesus & Mendonça, 2018) and interdependent (Kirchherr et al., 2018). The multi-faceted nature of the CE agenda, which calls for adopting the systems perspective, turns the attention to the argument that the barriers are interdependent.

Additionally, the role of digital technologies in the context of the CE agenda is developing. Initially, a one-way relation has been presented in the literature concerning the

enabling role of digital technologies for CE transformation, e.g. Rosa et al. (2020) and Rejeb et al. (2022). Most recently, the dual and synergetic relation between the two is being coined in the twin transformation, which has gained the European Commission's interest, which is using this terminology in their strategic initiatives (European Commission, 2022). However, despite its emergence, the empirical evidence of this synergetic relation is limited.

The following three sections address the current engagement in the twin transformation agenda and the barriers, including their interdependent relationships, experienced in doing so. The sections are based on the findings from two research activities, papers 1 and 2, followed by a joint reflection across the two research activities.

5.2. CONTEXTUALISING DEPENDENCIES AMONG BARRIERS TO CIRCULAR ECONOMY TRANSFORMATION

This section summarises and discusses the research described in paper 1, focusing on the barriers identified and their interdependencies. The following research question is made:

“How can interpretive structural modelling be used as an approach to contextualize barrier interdependencies toward a circular economy?” (Jensen et al., 2022)

Research background

The industrial transformation toward the CE is not straightforward for manufacturing organisations (Lahti et al., 2018). The agenda is multi-faceted, calling for adopting the systems perspective (Niero & Rivera, 2018) in designing and implementing its principles. Additionally, barriers are experienced and reported at different organisational and institutional levels (Ayati et al., 2022) while also exhibiting strong context-dependencies (Kirchherr et al., 2018). Therefore, the lack of acknowledgement of these interdependencies proposes the risk of sub-optimising and negative synergies for organisations undergoing their CE transformation.

The following research results from an investigation of utilising interpretive structural modelling (ISM) for contextualising interdependencies among the barriers experienced in a large Danish manufacturing organisation.

Research summary

This study observed that barriers to CE transformation are present at both organisational and institutional levels and are strongly linked. From the investigation of this large Danish manufacturing organisation, barriers are identified and clustered into the market, financial, technical, and regulative clusters as presented in Table 5.1.

Table 5.1 Identified barriers to the circular economy transformation (Jensen et al., 2022)

	Barrier	Description
Managerial	Risk aversion (RA)	Managers are inclined to favor a complete overview of the circular transition. As this overview is often absent due to high uncertainties, managers are hesitant to take risks.
	Lack of internal coordination (LOC)	The ability to effectively undertake a circular transition requires a coordinative effort across functions, including but not limited to service centers, logistics, production, quality, and sales. This has proven particularly challenging.
	Lack of inspiration (LOI)	As CE is new to the case company, they are actively seeking inspiration from other companies. However, demonstration projects are scarce.
	Unclear visions (UV)	Circular economy has caught the awareness of the case company. Yet, visions for the transition are unclear.
	Lack of knowledge and competences (LKC)	Employees experience a lack of knowledge about the principles of a circular economy as well as the competences to integrate them into their daily operations.
Market	Lack of partnerships (LOP)	The case company acknowledges that a circular transition requires partnerships with customers, suppliers, third-party service partners, and/or waste handlers as well as universities in ways that differ from past collaborative efforts. However, little is known about the required capabilities from partners.
	Unclear sales strategy (USS)	Selling refurbished products is difficult due to fluctuating availability. As the product return flow is unstable, availability of products cannot be guaranteed. Furthermore, questions are raised concerning sales channels.
	Lack of customer demand	Customer demand remains weak. Furthermore, it is questionable.

	and acceptance (LDA)	
Financial	Poor profitability (PP)	It is difficult for a take-back program to generate a profitable business case in the short term. Long-term profitability is considered probable but with high uncertainty.
Technical	Complex reverse supply chain (RSC)	Complexity of developing a reverse supply chain is high due to difficulties of acquiring products as well as product disassembly.
	Lack of circular design (LCD)	As products on the market have not been designed for a circular economy, disassembly of products is significantly hampered.
	Questionable reliability (QR)	As the case company produces high-quality products, concerns are raised about the reliability of refurbished products.
Regulative	Obstructing regulation (OR)	Obstructing regulation hampers take-back. To exemplify, end-of-life products are sometimes considered waste, which makes it difficult to import/export across borders.
	Lack of incentives (LI)	Few incentives are provided by national or international regulations.

The subsequent investigation of barrier interdependency reveals that all barriers are linked either directly or through intermediate barriers. This finding supports the general understanding and perception of the CE agenda as a multi-faceted system that is complex to navigate. That all barriers are interdependent in the final reachability matrix makes the method unfitting in guiding organisations in understanding and approaching their barriers systematically. This issue is addressed in Section 6.4 in which the operational potential of this model is presented and discussed. Due to the all-connected nature of the identified barriers in the final reachability matrix, the initial reachability matrix provides a more sequential interdependence network among directly linked barriers, as presented in Figure 5.1.

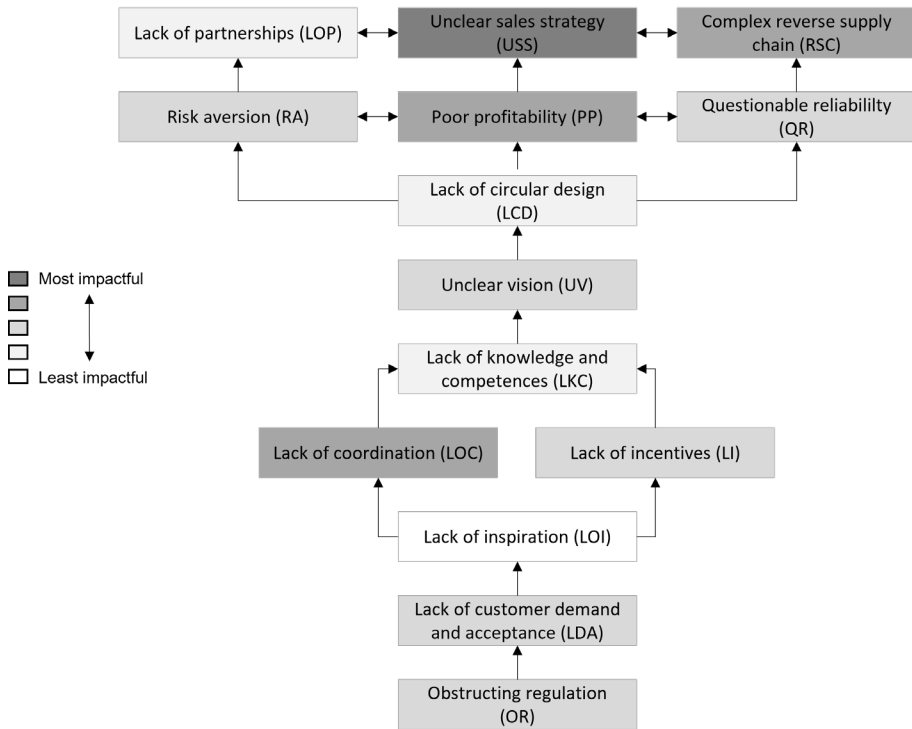

Figure 5.1 Interdependences among barriers to circular economy transformation (Jensen et al., 2022)

Analysing the identified and linked barriers show that external institutional and market-oriented barriers are foundational, yet only moderately impactful, to the CE transformation. In high-level terms, the lack of demand from the market causes a series of uncertainties and barriers concerning how the supply of products should be designed according to CE principles. Additionally, lacking inspiration on how to approach this agenda appears incapacitating in further organising and operationalising the CE initiatives, i.e. pulling the organisation out of its linear lock-in, as seen in the ‘lack of coordination’, ‘lack of knowledge and competences’, ‘unclear vision’, and ‘lack of circular design’. Risk aversion materialises in both successful and un-successful scenarios. The organisation is hesitant to engage with external partners from the quality and financial concerns of establishing take-back systems (i.e. an unsuccessful scenario). At the same time, the thought of success, paradoxically, is equally undesirable to the organisation in the scenario that the demand for sustainable products (e.g. remanufactured products) exceeds the supply that the organisation can produce.

5.3. SYNERGIES BETWEEN CIRCULAR ECONOMY AND INTERNET OF THINGS

This section summarises and discusses the research described in paper 2, in which the following research question is made:

“How do synergies between IoT and CE enable manufacturers to engage with the twin transformation agenda?” (Uhrenholt et al., 2022)

Research background

The link between CE principles and digital technologies is well-acknowledged in academia. Previously the link has been one-way, as the digital technologies enable the CE transformation (e.g. Rejeb et al., 2022). Most recently, the link is argued to be a two-way relationship where the digital technologies are a means to the end of achieving CE, while the CE represents a purpose for the digital technologies – This is being coined as the twin transformation agenda. However, the empirical evidence for this synergetic relation between the two constructs of the agenda is limited, while the industry is reportedly struggling with the two agendas independently (Kirchherr et al., 2018; Rejeb et al., 2022; Rosa et al., 2020).

The following research results from an investigation of this synergetic relation between the IoT (as a representative of the digital technologies of I4.0) and CE. This is a multiple case study of ten Danish manufacturers engaged in this agenda, although at an early stage.

Research summary

In this study, it is observed that the IoT capabilities and the CE strategies are mutually beneficial when pursued in conjunction. As a result, the barriers experienced for either of the two constructs of the twin transformation agenda can be neutralised from the contributing properties of the opposing construct, except for the barriers related to the organisations being data-centric which is hindering from both perspectives, as presented in Table 5.2 and Table 5.3. Furthermore, the link between the two appears to be close as the choice of CE strategy leads to the adoption of particular IoT capabilities and vice versa in most investigated cases, as presented in Figure 5.2.

Table 5.2 Barriers to the IoT implementation (Uhrenholt et al., 2022a)

Barrier category	Barriers (Singh, R. & Bhanot, 2020)	Case
Data	Data handling, Issue of data centric	A, B, C, D, E, F, G, H, I, J
Business	Lack of investment, Challenges in business model, Long payback period	A, B, C, D, E, F, I, J
Contextual	Need for talent and expertise	A, B, C, D, I, J
	Device specific (power efficiency, network architecture, device management, safety of devices, standardisation of devices, internet infrastructure)	F, G, I, J

Table 5.3 Barriers to the CE implementation (Uhrenholt et al., 2022a)

Barrier category	Barriers (Ayati et al., 2022)	Case
Business model / Operations design	Adopting a recovery approach, After-sale supports and lower lifecycle time, Lack of mature tech for adopting a recovery approach, Using feedback, Structure or communication methods	A, B, C, F, G, H, I, J
Data	Quality assessment and control, Integrating data between entities, Information about life use conditions, Reliable information, Mature technology for integrating data, Tracking take-back initiatives	A, B, C, D, F, G, H, J
Governance / Risk averse	Source/capability and incentive to invest, Leadership and management, Reluctancy, Priority of the organisation, Reliability along the supply chain, resource capacity, The wrong focus of regulation, Public education, awareness, and any social norms	A, B, C, F, G, H, I, J
Cost / Value	Risk of low profits and long time to pass the break-even point, Final price of a recovered product	D, F, G, H

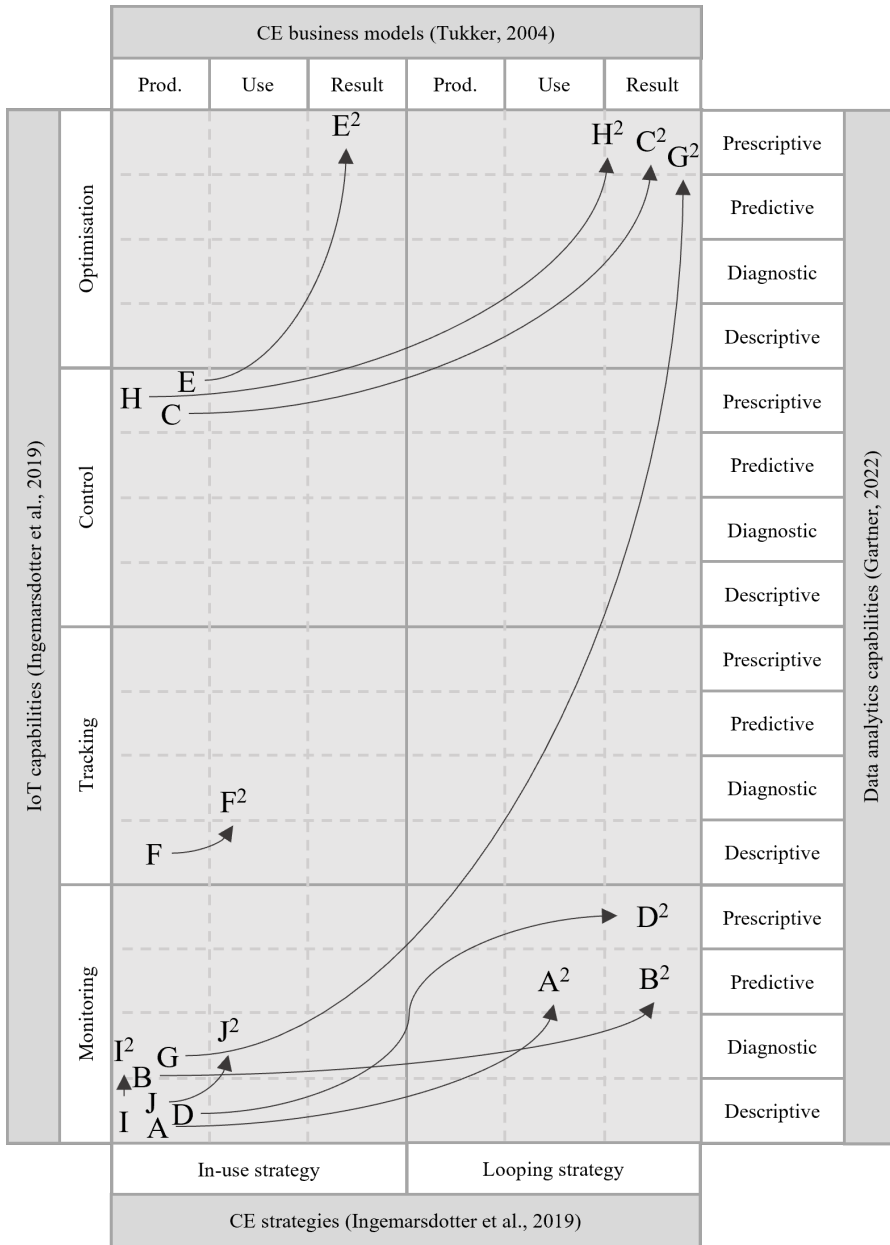

Figure 5.2 Synergies between the IoT capabilities and CE strategies in the twin transformation (Uhrenholt et al., 2022a)

From investigating these ten Danish manufacturers, we synthesise two propositions concerning the relationship between the twin transformation's two constituent constructs, the IoT (representing I4.0) and CE. The propositions are:

Proposition 1. *Data-driven decision making in the CE context: The IoT technology provides specific lifecycle data of individual products, enabling the transformation to serviced business models from the cumulative build-up of data and know-how of product performance, usage, and health.* (Uhrenholt et al., 2022a).

Proposition 2. *The strategic perception of IoT in the CE context: The CE context related requirements must act as a design parameter for introducing IoT technology to ensure its technological potential's strategic and sustainable relevance – Hence relieving it from its cost-based constraints.* (Uhrenholt et al., 2022a).

In brief, the propositions argue for the synergetic role of the two constructs. The introduction of the IoT can generate the data required for organisations to gain insights into the use and health of their products in the market, enabling data-driven decision-making accordingly. By introducing the IoT to the CE context, the technology is elevated from the constraining operational perspective in which it is usually perceived (Colli et al., 2021a; Lassen & Waehrens, 2021). As such, the evaluation of its value proposition is viewed not only from its short-term operational business contributions but also from its long-term strategic contributions or enabling properties for further strategic development.

5.4. REFLECTIONS

This phase of the research project has focused on uncovering Danish manufacturers' current level of engagement and development in the twin transformation. The two studies suggest that Danish manufacturers are in the initial phases of their transformation. In both studies, the manufacturers are primarily engaged in low-maturity activities. For example, the manufacturers have predominantly focused on circular processes that can be introduced into the organisation in an isolated manner, i.e. without interfering with other organisational dimensions and processes, such as introducing IoT to elevate service operations. The engagement with circular processes that are more invasive to the existing, linear operations is less present in the industry. Hence, we may deduce that the IoT capabilities and CE strategies related to a product-as-a-service business model represent high-maturity activities due to their complexity and required interference with the existing linear-based capabilities.

Across the two studies, we observe that the organisations find themselves very uncertain about the twin transformation agenda, as a lack of inspiration, knowledge and education in the circular principles hinder their progress. As such, it may be deduced, with the knowledge from the ISM-based study (paper 1), that the need for talent and expertise along with the issue of data-centric is, in fact, the root cause of the perception

of other highly reported barriers such as the device-specific barriers and the concern of data handling and reliable information as found in the multiple case study (paper 2).

The engagement in industrial sustainability seems not only to be made according to noble reasons, such as the environmental and social dimensions, but it also heavily relies on the expectations for economic performance. According to both studies, the concern for economic performance is central to IoT and CE engagement.

The role of digital technologies in the CE agenda is elevated from the sub-optimal category that has been seen before in the I4.0 literature. The short-term perspective that the manufacturers are adopting in discussing and implementing digital technologies limits the perceived value contribution of such implementation. The lack of long-term perspective puts the organisations at risk of sub-optimising their operations if the technology is not evaluated according to the CE principles and its long-term strategic direction. While the technology may aid in specific problem solving, the strategic potentials of the technology – e.g. IoT devices enabling product take-back strategies, from generating insights into the utilisation and ‘health’ of products in the market, are neglected. Additionally, the general emphasis of retrofitting the technology onto the existing products brings along positive reflections as it fits with the principles of cumulative capabilities, i.e. the organisations are building on top of existing capabilities. The manufacturers can swiftly and at a low cost explore the potentials of the technology in their context and hence build superior solutions by working iteratively with the retrofitted technology.

In summary, the industry is engaged in the twin transformation at a low level. Organisations are adopting simple and non-invasive solutions, while they are hesitant to work with more elaborate circular strategies, which is caused by a lack of inspiration, knowledge, and vision, which, first and foremost, leads to uncertainty in the financial performance of engaging in these strategies. Therefore, the findings from these studies suggest that the industry could benefit from tools and frameworks for guiding their engagement in the twin transformation while advocating the adoption of the systems perspective in which soft and hard dimensions of the transformation are considered across the short, medium, and long-term. For example, the adoption of the ISM methodology in the context of other Danish manufacturers holds the potential of contextualising their barriers to uncover the linkages and guide their transformation.

CHAPTER 6. DESIGNING THE CIRCULAR ECONOMY TRANSFORMATION

This chapter investigates the structural elements of the CE transformation in manufacturing organisations from a systems perspective, according to individual context needs. The chapter provides three elements to the design of this transformation. First, it addresses the organisational design using the concept of maturity to assess an organisation's current state of circularity and aid in formulating a strategy for further circular progression. Second, it presents how interpretative structural modelling can be utilised in the context of CE to contextualise the dependencies among present barriers to the transformation. Third, it provides an overview of the economic factors to consider in designing economically viable product take-back systems. Finally, from a systems perspective, this overview suggests how organisations can incorporate internal and external factors in the design.

6.1. INTRODUCTION

The increased attention towards the CE from both the institutional and the industrial level raises questions concerning the structural elements of this agenda and how they can be utilised to drive the transformation. As the CE is a multi-faceted agenda, it requires a systems perspective (Niero & Rivera, 2018) to understand its system boundaries and the interdependencies in system elements to avoid pitfalls of sub-optimisation. The CE is labelled as an organisational transformation, which, in turn, calls for the adoption of the cumulative capability perspective (originating from the resource-based view (Wernerfelt, 1984)) (Gold et al., 2017) as organisations must build on top of existing capabilities rather than deeming these obsolete (Corbett & Van Wassenhove, 1993). Furthermore, the maturity of the CE agenda, as being in a pre-paradigmatic phase, does not make the transformation easier for organisations (Pagoropoulos et al., 2017), e.g. as the terminology is not aligned, which, in turn, has resulted in explicit calls for research in assessment tools and guidelines for aiding organisations in their CE transformation (e.g. Nobre & Tavares, 2021).

Additionally, as we saw in Section 1.4, both large and small manufacturers in Denmark are challenged in adapting their operating model according to the CE principles. They find themselves incapacitated in the complex interdependent web of barriers for this agenda which calls for more strategically and systematic approaches for designing their engagement and transformation towards the circular operating model.

The following four sections address the formulation of CE strategies along with the operationalisation of the engagement according to the particular context and the barriers experienced herein. The sections are based on the findings from three research activities from paper 3, paper 4, and paper 1, respectively, followed by a joint reflection across the three research activities.

6.2. DESIGNING COMPANY-SPECIFIC CIRCULAR ECONOMY TRANSFORMATION STRATEGIES.

This section summarises and discusses the research described in paper 3 in which the following research objective is made:

“To propose, from a systems perspective, a maturity model for the circular economy transformation for the manufacturing organisation.” (Uhrenholt et al., 2022b)

Research background

The concept of maturity has, since the late '70s, been adopted in guiding the industry in developing capabilities within specific agendas (Wendler, 2012), starting with quality management (Crosby, 1979) and data processing (Nolan, 1979), while it more recently is utilised in the large agendas of digital transformation (Colli et al., 2019) and CE (Sacco et al., 2021). The pre-paradigmatic state of the CE has already resulted in a selection of different maturity models and studies that apply varying terminologies in assessing the level of industrial engagement in the CE. However, most existing maturity models and assessment tools do not adopt a systems perspective, as they adopt specific contextual constraints, such as geographical regions (Ormazabal et al., 2018) or focus on a subset of circular principles, such as circular product design (Berzi et al., 2016). Furthermore, the existing models contain limited prescriptive properties, as they provide little insight into what constitutes increased CE maturity relative to the assessing organisation, as they are formulating assessment scores through quantitative measures or grades.

Therefore, this research is initiated to support and act on the calls for research in adopting the systems perspective in guiding the CE transformation and developing assessment tools to guide practitioners in their transformation. The research results from conceptual model development are grounded in the cumulative capabilities perspective.

Research summary

This research presents a novel CE maturity reference model, outlining the transformation journey, from the micro-economic perspective, across six organisational dimensions that are unfolded through six cumulative CE maturity levels.

The maturity model takes an offset from extant literature, which is utilised for identifying and defining the organisational dimensions relevant to discuss in the CE transformation, along with the nuances in maturity progression from the explication of discrete maturity levels. The investigation of organisational dimensions led to the definition of six central organisational dimensions to discuss in pursuing the CE principles. These are presented in Table 6.1.

Table 6.1 Dimensions of the organisational circular economy (Uhrenholt et al., 2022b)

Dimension	Definition
Value Creation	The models utilised for generating and capturing value from CE activities (e.g., sales models, take-back programmes, life-extending services) and environmentally positive performance (e.g., resource and emissions savings and regeneration).
Governance	The strategies and plans for the circular transformation (e.g., resource allocation, circular awareness, and engagement on different hierarchical levels).
People and Skills	The mindset and skills (both internally and with external partners) required for enabling and acting on the circular transformation (e.g., circular competencies, learning, and training culture).
Supply Chain and Partnership	The stakeholders external to the organisation required for the exchange and optimisation of materials, products, and activities (e.g., shared visions and activities, engagement with external experts).
Operations and Technology	The equipment and systems in place for performing CE activities (e.g., machinery and tools, systems aiding the scheduling and identification of appropriate treatment according to value potential).
Product and Material	The characteristics of the products that enable circular strategies and activities (e.g., extended life cycle, simple disassembly, and refurbishment).

Subsequently, six discrete maturity levels are defined from the investigation of extant literature. These are labelled according to the primary capability that characterises them, as presented in Table 6.2. The maturity levels are built on the principles of systems thinking (Checkland, 1999) and expertise (Dreyfus & Dreyfus, 2005) – both well-known principles in the discussion of maturity. The principle of expertise concerns the presence of heuristics in the decision-making process within the organisation. As the circular maturity levels increase, the circular principles gradually become a natural and nuanced part of the heuristics. The principle of systems thinking concerns the level of embeddedness of circular principles in the organisational operating model. At low maturity, the CE principles may be present in a few isolated corners of

the organisation, while higher maturity is characterised by these principles being integrated throughout the operating model coherently.

Table 6.2 Levels of organisational maturity for the circular economy (Uhrenholt et al., 2022b)

Dimension	Definition
None	There is no presence of circular awareness, elements of circular economy in strategies, or related activities in the organisation. Only legal requirements, e.g., for waste handling, are in place.
Basic	The need for CE appears in the organisation, and discussions about how and where to act are happening. Few, unintentional CE principles generate value.
Explorative	Demonstration projects and pilots are initiated across different functions in the organisation to prove the value of the circular economy and to test organisational capabilities.
Systematic	Means for pursuing CE are implemented, by design, throughout the organisation. Successful pilots are implemented, and scaling is initiated.
Integrative	Circular initiatives and ambitions are aligned throughout the organisation and its critical supply chain.
Regenerative	The organisation is truly engaged in the circular economy and is regenerative and restorative by intention and design.

The desire to develop a prescriptive maturity model for the CE transformation required that the organisational dimensions be directly linked to the maturity levels in a manner that enabled the individual organisation to assess its current level of maturity and develop its subsequent, desired level of maturity. This argument was based on the proximal zone of development (Harland, 2003), from which the maturity model can be labelled as the scaffolding object that enables and guides the organisation in moving from its current zone of development to its proximal zone of development. The correlation between each of the six CE dimensions across the six maturity levels is explicated in Table 6.3.

Table 6.3 Circular economy reference model (Uhrenholt et al., 2022b)

	Value Creation	Governance	People and Skills
None	No value is created from CE activities. Waste and emissions are only a concern when imposing cost.	No attention is paid to the circular agenda, and it is not present in the strategy.	No skills for CE are present in the organisation, nor is training for CE in place.
Basic	Waste management generates income. Emissions and waste reductions are achieved through simple “Avoid and Reduce” initiatives.	Simple initiatives emerge sporadically in the organisation. CE has no critical role in the strategy.	No formal training. Few knowledgeable and/or curious resources.
Explorative	Value is generated through learning and experience in explorative activities regarding CE principles. Sustainability still imposes a trade-off with the traditional performance measures from a lack of appropriation.	Few organisational resources are (partially) allocated to CE. CE is present in the corporate strategy, but it is not operationalised.	Search for knowledge results in sporadic learning activities for dedicated resources. CE is in focus when recruiting.
Systematic	Value generation and capture increase as appropriation of CE increases. Trade-offs among performance measures persist from long time lag of previous decisions.	CE is incorporated into the organisational design while the CE strategy is operationalised with defined objectives and activities.	Formal training and knowledge dissemination for critical employees occurs.
Integrative	The focus of appropriation is turned outwards, targeting supply chain optimisation. Multiple circular loops are generating value, for which internal processes and design are effective.	The CE strategy focuses on the supply chain while CE is well-established internally.	CE competencies are part of employee DNA. Formal training with supply chain partners is operationalised.
Regenerative	Value is generated from optimised use and cascades between all circular loops.	CE is embedded in the strategy and management of the organisation.	CE competencies are strategically prioritised throughout the organisation and with external partners.

	Supply Chain and Partnership	Operations and Technology	Product and Material
None	No CE-related engagement with business partners or knowledge institutes.	No activities related to CE are taking place internally or in the supply chain.	The product and its materials are not designed or optimised for CE.
Basic	No activities with an explicit focus on CE. Simple environmental improvements with economic benefits are realised.	Simple changes are made to operations to reduce waste and emissions. Operational principles (e.g., just-in-time) are in place to avoid waste.	Product performance and material composition are optimised from traditional cost and quality perspectives.
Explorative	Explorative projects are executed with a single external partner. Few, one-off, engagements with knowledge institutions take place.	Simple workstations are set up to explore disassembly for R-strategies. Due to the lack of formal procedures, activities in operations and supply chain are hand-held.	Explorative activities around “Design for X” and real-time product health are performed for future product releases. The recycling quality of existing products and materials is tested.
Systematic	Projects with external partners and knowledge institutions are formalised.	Circular processes are formalised alongside existing forward operations. Investments are made to meet expectations of efficiency and effectiveness.	New products and materials are designed for narrowing, slowing, closing, regenerating, and connecting circular strategies.
Integrative	Infrastructure enabling the exchange of physical and digital resources is well established.	Advanced technology is implemented for automating supply chain information flow for optimising the physical flow of materials and products.	Product health data are available throughout the supply chain, enabling prolonged life cycles and maintaining products in circular loops.
Regenerative	The supply chain facilitates a seamless flow of materials, waste, and information.	Internal and supply chain processes are designed for CE to provide effective and efficient processing of products and materials.	Products are designed for CE, hence material use is minimised while product life cycle is maximised.

For organisations to progress in circular maturity, the concept of ambidexterity is of interest. Ambidexterity concerns the simultaneous deployment of explorative and exploitative capabilities in the organisation – despite fundamentally contradicting the two strategies. In the context of CE transformation, organisations must adopt and deploy explorative capabilities, especially in the initial maturity phases of their transformation. These activities should emphasise learning and the potential of adopting circular principles to the existing operating model, while exploitative activities should be maintained for the existing linear operating model. However, as the organisational maturity level increases, organisations will find themselves at an inflexion point where they must translate the learnings from the explorative activities into exploitative activities according to the circular principles. The conflict at this inflexion point originates from the need to transfer or transform the linear principles into circular principles. This conflict is, among other things, related to the need to change organisational structures and processes, which will impose a temporary performance dip on the organisation (Bockholt et al., 2020; Uhrenholt et al., 2022c).

In summary, the proposed maturity reference model contains prescriptive properties and provides a systems perspective to the circular organisational transformation as it enables the manager to assess their engagement in the agenda across the six dimensions while considering the guiding principles that define higher maturity levels for guiding their further engagement in the transformation.

6.3. DESIGNING FINANCIALLY FEASIBLE PRODUCT TAKE-BACK SYSTEMS

This section summarises and discusses the research described in paper 4 in which the following research question is put forward:

“What factors affect the financial performance of product take-back, and how do they affect the financial performance?” (Uhrenholt et al., 2022c)

Research background

Within the CE, the product take-back is an essential strategy in recovering residual material and functional value from the market. However, the industry is challenged in designing and operating product take-back systems that are financially feasible (Sepúlveda-Rojas & Benitez-Fuentes, 2016), as products are losing their functional value gradually when moving through the reverse supply chain (Blackburn et al., 2004). This has led to calls for research into financially sound business models in which product take-back plays a central role (Hvass & Pedersen, 2019).

Additionally, as we saw in Section 1.4, both large and small manufacturers in Denmark are, despite high expectations of the financial performance of CE principles, challenged in operationalising the cost and value drivers of the agenda and hence are

questioning its profitability. In-use strategies are adopted in favour of looping strategies which may be explained by the risk aversion seen at the large Danish manufacturer, which is grounded in uncertainties concerning the quality of remanufactured products and the cost of processing these, along with the novelty in the activities that must be organised, both internally and with supply chain partners.

Therefore, this research is initiated to support and act on the calls for research on the financial performance of product take-back systems. As extant literature approaches the multi-faceted CE domain by deep diving into various topics, e.g. product design (Bocken et al., 2016), business models (Kjaer et al., 2019), reverse supply chain (Blackburn et al., 2004), and legislation (Atasu & Van Wassenhove, 2012), a systematic literature review is conducted for identifying and compiling the factors that are interesting in the discussion of the financial feasibility of product take-back systems.

Research summary

This research presents 12 factors identified in the extant literature that are found to play a significant role in the financial feasibility of product take-back systems from the organisational perspective. The systematic literature review was conducted using the five-step methodological approach by Denyer & Tranfield (2009). Figure 6.1 visually presents the steps taken in identifying and evaluating the extant literature base.

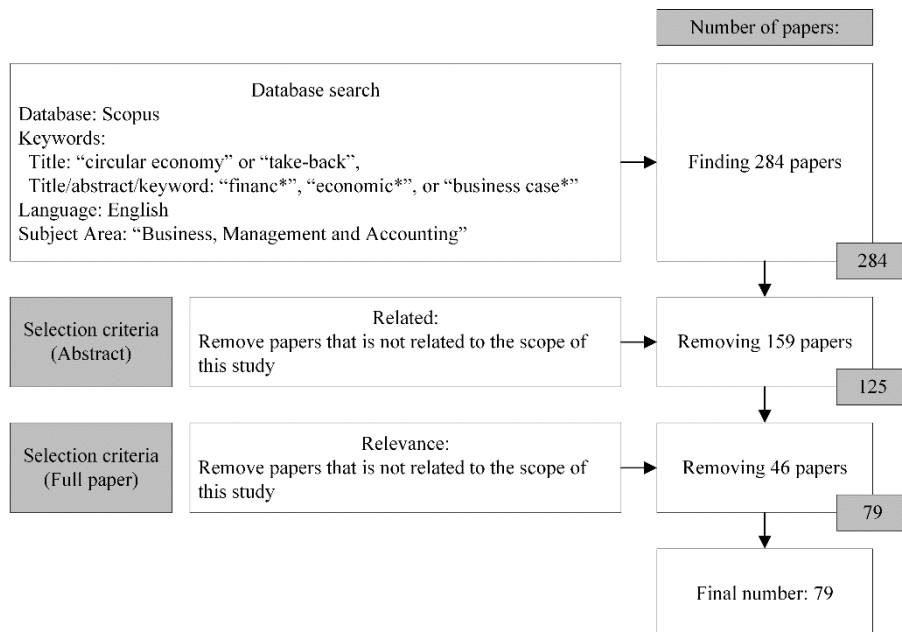

Figure 6.1 Data collection and selection process (Uhrenholt et al., 2022c)

The 12 identified factors are clustered into three dimensions, one containing two sub-dimensions (Uhrenholt et al., 2022c). These are:

- Context – External factors to the individual organisation, such as public governance structures.
- Supply chain – Factors related to the supply chain of the individual organisation, such as supply chain actors and collection methods.
- Company – Internal factors to the organisation, such as earning models and customers. Two sub-dimensions are identified:
 - Product – Factors directly linked to the product, such as EoL value and product design.
 - Operations – Factors related to the handling and treatment of collected EoL products.

The 12 factors are presented in Figure 6.2 in which the factors are unfolded concerning their impact on the financial performance. In addition, a distinction is made between cost and value, both of which can increase and decrease the system's financial performance. Accordingly, based on the findings, we put forward two propositions concerning the financial performance of product take-back and how managers can acknowledge the relevance of all three economic levels in its design. The propositions are:

Proposition 1. *“From the outside and in: In designing product take-back systems, the external context and supply chain should be considered inputs for decisions regarding internal factors to improve the system’s financial performance.”* (Uhrenholt et al., 2022c).

Proposition 2. *“Cost and Value trade-off: In product take-back, high-value capture is achieved at a higher operational cost, while low-value capture comes with a lower operational cost. This relation between value and cost suggests a natural optimum for how much cost to put into capturing value relative to the product's value.”* (Uhrenholt et al., 2022c).

		Financial performance	
Context		Cost	Value
Legislation		Increased due to taxation of labour and weight, and the disparity between national legislations. Decreased due to creating infrastructure for take-back.	Decreased due to regulatory obsolescence.
Standards		Decreased due to affecting system enablers.	Increased through standards for remanufacturing products removing customer uncertainty.
Financing		Increased from limited financing options for investment in cost reduction. Decreased from potential public financing in take-back	Decreased due to limited financing options for improved value capturing.
Supply Chain			
Partnerships and collaboration		Increased due to not utilizing capabilities in the supply chain from lack of collaboration. Decreased by collaborating with 3rd-party waste collectors to achieve economies of scale.	Decreased as value if left unrecovered due to not utilizing capabilities of supply chain partners.
Reverse logistics		Increased by frequent, dispersed, and low volume shipments. Decreased by using 3rd-party waste collectors, early sorting and proximity to products.	Decreased if IPR is lost in the consolidated systems.
Company			
Business model		Decreased from established customer contact and take-back in servitized business models. Increased if the cost of remanufactured materials is larger than virgin materials.	Increased through prolonged life-time and servitization revenue, and opening up for new markets for remanufactured products. Decreased through cannibalization effect.
Customer awareness		Decreased when customers are aware of product take-back, easing the collection process.	Increased through better brand value affecting sales of products. Decreased due to customer not wanting used products.
Product			
Functional value		Increased to achieve the inner resource loops due to cost of requalifying products, components or materials	Increased by reaching inner resource loops. Decreased if data are missing on the usage of the product, or if wear and tear are high, leading to lower value resource loops.
Material value		Decreased material cost through reusing materials. Increased if virgin materials are cheaper than reusing materials.	Increased value from selling waste material. Decreased value as reused materials can be of worsened quality.
Product design		Increased through changes in design over time, removing the ability for efficient operations. Decreased from standardization components and design-for-disassembly principles.	Increase for timeless designs, that enable repair and creates a second-hand market. Decreased if product design changes rapidly, leaving only material value to be captured.
Operations			
Methods		Increased cost of recovery if manual disassembly is needed. Decreased from using automation and digital technologies for locating and sorting products.	Increased if disassembled manually and if value recovering capabilities are internal. Decreased when destructive methods are used.
Process		Decreased by early sorting of products, standardized procedures and training. Increased with high recycling rates from the cost of technology and varying salary levels.	Increased by matching demand for products with recovery options.

Figure 6.2 The factors affecting the financial performance, as specified in cost and value, of product take-back systems (Adapted from (Uhrenholt et al., 2022c))

6.4. CONTEXTUALISING AND PRIORITISING CIRCULAR ECONOMY BARRIERS TO OPERATIONALISE THE TRANSFORMATIONS

This section summarises and discusses the research described in paper 1, focusing on the methodological approach and its potential. The following research question is made:

“How can interpretive structural modelling be used as an approach to contextualize barrier interdependencies toward a circular economy?” (Jensen et al., 2022)

Research background

The multi-faceted nature of the CE agenda, e.g. as seen in the vast amount of barriers reported in extant literature (Ayati et al., 2022; De Jesus & Mendonça, 2018; Urbinati et al., 2021), induce a web of contingencies (Kirchherr et al., 2018) to manufactures facing the circular transformation. Therefore, managers must understand these contingencies and the systematic dynamics among the barriers they face to navigate and prioritize resources in their engagement in the transformation.

Accordingly, there is a need to investigate the adoption of a systems perspective in understanding the interdependencies among CE barriers to enable managers to structure and directing their engagement in the agenda. The following research is the result of an investigation of utilising ISM for contextualising interdependencies among the barriers experienced in a large Danish manufacturing organisation. This research study is also presented in Section 5.2, focusing on the barriers identified in the case study. However, the focus of this section concerns the methodology as a tool for organisations to progress in their CE transformation.

Research summary

This research exemplifies how the ISM methodology can be utilised, not only as a means for understanding the barriers and their interdependencies but as “a means to an end to secure a knowledge base through which practitioners can obtain a contextualised understanding of the barriers that they encounter” (Jensen et al., 2022). While the methodological approach of ISM is well-represented in the academic literature for its properties in investigating the linkages among variables, its practical potential as a methodology for practitioners to understand interdependencies among variables in their given context has received little attention.

In doing so, the following research design presents the steps to conduct this study. While the process depicted in Figure 6.3 represents a research design, the steps in-

involved present the process practitioners could adopt to address their CE transformation by contextualising the barriers they face, and hence, enable the organisation to address the problem chains (Johansen et al., 2006) that evolve from this investigation.

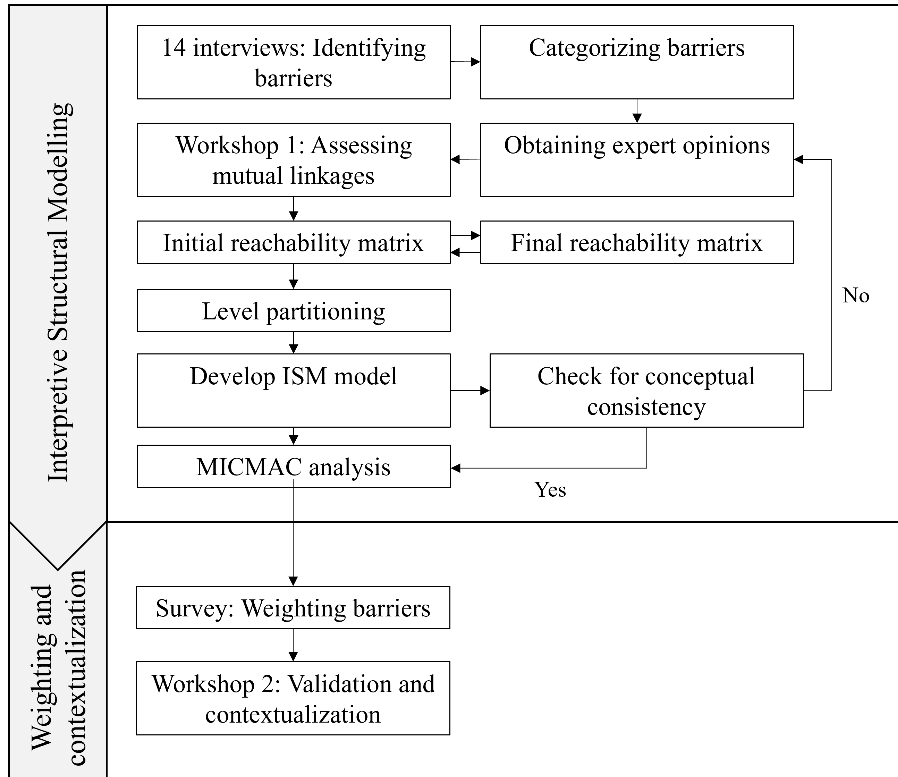

Figure 6.3 ISM research design (Jensen et al., 2022)

This research finds that the methodology is challenged in agendas of such high complexity as the CE. When checking the barriers for transitivity, i.e. moving from the initial reachability matrix to the final reachability matrix, this study finds that all barriers affect one another, i.e. all barriers hold the same dependency and driving power, which makes the methodology incapable of guiding practitioners in its traditional form. Therefore, the transitivity check should be skipped for this method to provide a contextual overview of barriers in highly complex agendas. While this may be argued as a limitation of the methodology, it may also be argued that flexibility allows for the contextualisation of barriers not only in dealing with high complexity (in which the transitivity analysis is skipped) but also in dealing with agendas containing barriers that appear dispersed to the naked eye – for which the transitivity may generate the links necessary to construct the problem chains.

Furthermore, the involvement of practitioners in conducting this research is critical in uncovering the contextualisation of the barriers experienced in the context. Where previous research adopting the ISM methodology sought to generalise barriers at an industrial level, the contextual contingencies at the individual organisation and its CE maturity level are influential to the barriers experienced. Alternatively, organisations may base activities and form strategies according to generic CE barriers, resulting in disproportionate root cause identification and misguided mitigation paths. Accordingly, the barriers and their interdependence identified in this research reflected the immature state of development observed in this industrial case, i.e. the focus on governance processes such as defining strategies and coordinating activities. As such, it is expected that applying this methodology in a more mature organisation would reveal a different set of barriers and linkages accordingly.

6.5. REFLECTIONS

During this chapter, three contributions have been presented, each addressing the design and engagement to the organisational CE transformation from varying perspectives. First, the CE maturity model suggests the dimensions and maturity levels an organisation should consider in its transformation from a systems perspective. The ISM methodology may follow this to organise the most present barriers to progressing in the agenda, connecting the dots between dispersed issues. Lastly, the literature review presents the complexity of the central product take-back strategy, which is found to be scarcely adopted among Danish manufacturers in the previous phase of the research project. The review presents a list of 12 factors to consider, some of which are contextual contingencies that a take-back system must be designed according to, resulting in a rather complex system.

The previous phase of the research project (papers 1 and 2) suggests that organisations are challenged in designing the engagement in the CE agenda and that the emphasis on hard dimensions overshadows the soft dimensions. At the same time, they did recognise that awareness and competencies in the agenda are lacking, constraining factors in further progressing accordingly. The proposed CE maturity model (paper 3) emphasises the systems perspective in the CE transformation by focusing on 'hard' dimensions, such as specific circular processes, and emphasising the need for 'soft' dimensions, such as governance and people and skills. The maturity model does not contain a proposed approach for conducting the activities concerning the assessment and the proposal of future CE activities for improving the maturity level. To operationalise this model in industry, the currently low maturity level of the industry must be considered. First, in introducing the model and the subsequent process an organisation embarks on when utilising it, emphasis must be put on creating awareness of the CE and its principles. This aims to create a shared understanding among the participants in what constitutes higher CE maturity, allowing them to imagine their

context to be changed accordingly. Secondly, the process facilitator should be an expert within the CE domain to properly facilitate the discussion of contextualising the CE principles.

Furthermore, the previous research phase found that product take-back systems along with product-as-a-service business models are yet to be adopted by manufacturers, which stresses the relevance of the literature review as a means for providing the industry with this map of factors – guiding them in engaging in product take-back. The comprehensiveness of the factors identified in the literature review emphasises the need for adopting a systems perspective in the CE transformation. The single circular process of product take-back involves a set of internal factors to consider – It also includes factors in the supply chain and institutional factors that all affect how such a system should be designed from the perspective of economic performance. The complexity increases further as the design of a product take-back system is to be incorporated into an organisation with existing capabilities (expectedly based on the linear economy principles), while it should match other circular processes.

The three contributions presented in this chapter all hold individual potentials for the organisation, while the combination suggests a more comprehensive and value-driven approach to the engagement and design of the CE agenda. The maturity model intends to assess the entirety (or a business unit for larger organisations) of the organisation and hence develop a strategy for further development accordingly. Subsequently, the ISM methodology can be utilised in operationalising and contextualising the barriers at a more granular level, e.g. by scoping the methodology to encompass specific strategic initiatives such as a product take-back program or adopting a product-as-a-service business model. Lastly, the literature review findings do not propose a process as such; rather, it may be utilised as a checklist in the organisational discussion of the establishment and performance of a product take-back system. Additionally, the factors from the review may be utilised as the outset in discussing the barriers to product take-back according to the ISM methodology. While such use ensures a systems perspective in the discussing, according to the extant literature, the drawback is the risk that respondents will not consider factors that were not identified in the review – therefore missing potentially critical factors to the particular context.

CHAPTER 7. EXPLORING AND EXPLOITING IOT FOR CIRCULAR ECONOMY

This chapter suggests how organisations can engage in explorative and exploitative activities concerning the use of IoT technology for the twin transformation agenda. First, it addresses the explorative activity of investigating the potential value of introducing IoT to existing operations in pursuing circular principles. From this, an operational framework is developed. Second, a self-assessment framework is developed, focusing on exploiting existing IoT technology, with a primary focus on the service and the interface layer, the IoT architecture, to reveal unexploited potential.

7.1. INTRODUCTION

The relation between the CE and the digital technologies presented in the I4.0 agenda is well-argued in the extant literature, e.g. (Nobre & Tavares, 2017). However, industrial engagement with digital technologies is challenged in general. For example, literature reports that the industry is challenged with contextualising the use of digital technologies to provide value in the particular context (Moeuf et al., 2018; Veile et al., 2019), and that they are primarily challenged with sensing and seizing capabilities if using the dynamic capabilities terminology (Larsen et al., 2021).

Additionally, as we saw in 0 and 6, both large and small manufacturers in Denmark face barriers in introducing digital technologies in pursuing circular principles, while they acknowledge that these are available and relevant in this agenda. Furthermore, manufacturers risk adopting digital technologies from a pragmatic and short-term perspective, which imposes a sub-optimisation concern, as they do not consider the long-term competitiveness potential when introducing the technology (Colli et al., 2021a; Lassen & Waehrens, 2021).

The following three sections address IoT technology's explorative and exploitative work in pursuing CE principles. The sections are based on the findings from two research activities, papers 5 and 6, followed by a joint reflection across the two research activities.

7.2. CONTEXTUALISING THE DESIGN OF IOT SOLUTIONS.

This section summarises and discusses the research described in paper 5, in which the following research question is made:

“How can the process of designing an IoT solution be addressed in order to tailor it to context-specific application needs?” (Colli et al., 2021b)

Research background

The IoT technology is presented, both in academic and grey literature, as a catalyst in the I4.0 agenda, due to its capability to connect physical and digital objects, thereby generating transparency across operational processes (Haddud et al., 2017). Accordingly, organisations can make enhanced decision-making founded on the increased information foundation, leading to increased competitiveness (Zhu et al., 2018). However, organisations are challenged in introducing IoT technology into their existing operations (Tortorella & Fettermann, 2018; Veile et al., 2019). Furthermore, it is a lack of research into the process of contextualising the IoT technology according to operational needs (Martinez, 2019; Moeuf et al., 2018) which, in turn, limits organisation’s ability to translate the exploration of IoT technology into exploitative business value (Papachroni et al., 2015).

Additionally, as observed in Chapter 5, Danish manufacturers are facing barriers in working with IoT in their pursuit of enhancing industrial sustainability through the CE principles. However, when organisations introduce IoT to their operations, it is done from a ‘problem-solving’ agenda in which they introduce IoT to isolated parts of their operations; hence they are not challenging the status-quo of the linear operations design.

Therefore, this research is initiated to address the gap in extant literature concerning the lack of organisational guidance for the balanced exploration and exploitation of IoT technology in existing operations. The research results from a design science research study from which a six-step framework is developed to guide organisations in contextualising the IoT-solution design.

Research summary

This research presents a novel framework for systematically ensuring the contextual fit and business potential when designing idiosyncratic IoT solutions for existing operations. The framework consists of six phases that guide the manager in balancing explorative and exploitative characteristics through a learning process focusing on understanding the existing operations, scoping desired future scenarios, and specifying idiosyncratic IoT solutions accordingly. The first two phases concern the mapping and analysis of existing operations, followed by two future-oriented phases focusing on exploring future configurations and identifying the business potential in moving from the current state to the desired future one. Subsequently, the last two phases

concern the specification of the idiosyncratic IoT solution according to the definition of the information flow required to meet the desired future state. The six phases are elaborated in Table 7.1, including the activity performed, the approach taken to do so, the data required to perform the activity, and the outcomes.

The framework is developed from a process excellence perspective, according to the belief that this is beneficial in understanding the implementation possibilities when generating business value from implementing new technology (Martinez, 2019). Systematic mapping and analysis represent a central element of the process excellence perspective to identify improvement potentials, e.g. through explicating value-adding and non-value-adding time. Such activities enable organisations to identify where current operations can be subject to improvements through the adoption of novel technology while quantifying the improvement potentials – thereby addressing both the explorative and exploitative activities that are called for in organisational engagement in the I4.0 agenda (Sahi et al., 2020). The continuous improvement perspective and the business process reengineering perspective offer two different yet complimentary approaches within the process excellence domain. While the continuous improvement perspective concerns minor changes to the existing operations design with long-term results in scope, the BPR represents a radical approach for redesigning the operations, achieving results immediately from the ‘new beginning’ (Martinez, 2019). As this framework emphasises the design of novel, idiosyncratic IoT solutions, the BPR perspective suggests a better fit as it enables the re-design of existing operations when investigating the introduction of novel technology.

Table 7.1 IoT solution design framework (Colli et al., 2021b)

Phase	Activity	Ap- proach	Data	Outcome
Opera- tions mapping	Mapping of the business processes	VSM	Activities and information to support decision-making processes regulating the activities	Qualitative and quantitative description of the targeted business processes
Opera- tions analysis	Identification of the issues and criticalities concerning the mapped processes in regards to the company competitive needs	VSM	Value-adding and non-value-adding activities concerning the mapped processes. Entities and implications of the non-value-adding ones	Selection of the key issues and criticalities to be addressed through the enabling transparency

Target situation definition	Proposal and mapping of the ideal (“reengineered”) business processes supported by the enabling of transparency	VSM	(Proposed) activities and information to support decision-making processes regulating the activities	Outline of solution concept and definition of industrial requirements for guiding its development and of solution features to achieve them
Performance improvement potential	Discussion concerning the potential improvement related to the transition from the current to the target situation	Gap analysis	Operations mapping, target situation mapping, entity and implications of the addressed issues and criticalities	Qualitative and quantitative description of the impact of the proposed solution
Information flow definition	Definition of the information flow for sustaining the target situation activities	GQM	Industrial requirements, solution features to achieve them, qualitative description of what data support decision-making processes supported by the solution	Outline of the information flow to be processes by the solution (identification of the gaps with the existing one)
Solution component definition	Definition of the technical components needed for processing the information flow	TTF	Organisational strategy of the company, functional needs concerning the information flow processing	Outline of the solution infrastructure and of the technical components to be deployed

7.3. CONTINUOUS IMPROVEMENT OF EXISTING IOT SOLUTIONS.

This section summarises and discusses the research described in paper 6 in which the following research question is made:

“How can companies identify continuous improvement potential related to the integration of IoT?” (Nygaard et al., 2020)

Research background

The multi-faceted nature of I4.0 (Colli et al., 2019), combined with the individuality of organisations, generates a complex web of contingencies when engaging in the agenda in pursuing business value. Accordingly, generic frameworks fail to support organisations in providing contextualised guidance on how and what to do in the agenda (Colli et al., 2018). For manufacturers to be enabled to be self-sustaining in improving their process excellence, they must be supported in moving from their current zone of development to their proximal zone, using appropriate boundary objects (Harland, 2003). Accordingly, manufacturers will benefit from using boundary objects that are self-assessments, as these promote constructive dialogue and a common ground for development in the organisation (Caffyn, 1999).

Therefore, this research is initiated to address the need for operational guidance to managers in enabling the self-controlled and continuous monitoring and exploitation of their processes using IoT. The research is a result of a design science research study.

Research summary

This research presents a self-assessment framework for supporting managers in enabling a more situational digital transformation and ensuring the appropriate level of exploitation of existing IoT technology. The framework consists of five phases guiding the assessment of the current exploitation of IoT technology, focusing on understanding the current processes, its information flowing, the technology deployed, and the unexploited value creation from said technology. The first two steps concern the scoping of the critical business process and its driving business performance measures, along with mapping these processes according to the well-known value stream mapping from the Lean methodology. The subsequent two phases concern the mapping of the information flow, focusing on the data source, data sink, and data storage space, followed by a mapping of the technologies that are utilised in processing the information flow, whether a physical (e.g. paper) or digital flow (e.g. IT systems). Finally, the technologies are mapped according to the current utilisation for processing the information flow and their potential capabilities, as depicted in Figure 7.1.

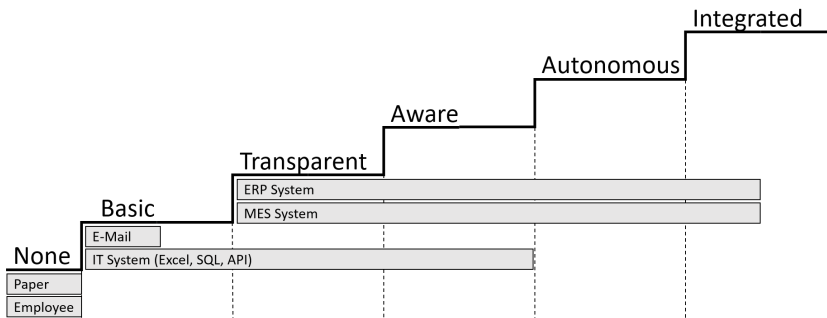

Figure 7.1 Example of integration of OT plotted in relation to their digital capabilities (Nygaard et al., 2020).

The framework is developed with the tactical and operational perspectives in scope, emphasising the need for practitioners to be tangible through a short time from analysis to realised performance improvements while maintaining independence from external experts (Mittal et al., 2018). Accordingly, the framework comprises existing and well-known tools to increase the user's immediate familiarity with the framework and potentially build on top of existing mapping capabilities within the organisation, according to the cumulative capabilities' perspective. The novelty of this framework comes from the explicit focus on the information flow in the value stream mapping, as elaborated by (Meudt et al., 2017), followed by the digital maturity model (Colli et al., 2019) as a reference point for the assessment of currently deployed technology and its improvement potential accordingly. As a result, the framework translates the use of the well-known value stream mapping into a digital transformation-related tool, thereby facilitating the identification of sub-optimal use of existing technologies according to the digital agenda.

7.4. REFLECTIONS

In this chapter, two contributions have been presented, focusing on organisational engagement with IoT technology in existing operations, but from varying perspectives. The first framework, comprised of a six-step process, propose how organisations can explore the value and potential of implementing IoT technology to existing operations, hence focusing on understanding the existing operations design, scoping new and optimised design of said operations, and matching these desires to the technological capabilities available in the market. This is followed by a five-step process framework proposing how organisations can independently assess their current exploitation of existing IoT solutions relative to the capabilities of said technologies. The framework intends to create awareness around and optimise existing technological capabilities, enabling organisations to generate unrealised value from existing technological capabilities. Both frameworks adopt the process excellence perspective and build on tools and frameworks from the well-established lean toolbox that is highly adopted

and adapted in the industry, along with more recent frameworks that have emerged from the I4.0 agenda.

The first phase of the research project (papers 1 and 2) suggests that organisations are challenged in their exploration and exploitation of IoT to enhance their engagement and create business value in the CE agenda. Furthermore, ‘soft’ barriers, such as the lack of inspiration, knowledge, and coordination, are found to be preceding the ‘hard’ barriers, such as lack of circular design and poor profitability. This implies that organisations are asking ‘how’ questions (e.g. “how do we approach the agenda”) before asking the more operational ‘what’ questions (e.g. “what should our product design look like”), which turns the attention toward the process of engaging with the technology and exploring its value, rather than emphasising the specific design of entities within the operations design. Furthermore, the insights from paper 2 call for simple, i.e. low cost and easy to adopt, frameworks for guiding and systematising the process of exploring the technology in their existing operations, i.e. in the brownfield context, as is also called for in recent literature (Leitz et al., 2018; Veile et al., 2019).

Subsequently, phase 2 of the research project (papers 1, 3, 4) suggests the following. First, it supports the need for and clarifies the role of digital technologies in the CE agenda as a central toolbox in generating and capturing value, e.g. through “automating supply chain information flow for optimising the physical flow of materials and products” (Uhrenholt et al., 2022b). Second, it discusses the importance of organisational ambidexterity, i.e. the balanced and simultaneous engagement with exploration and exploitation activities. The CE maturity model (paper 3) explicitly emphasises the exploration of CE principles across the six organisational dimensions. The IoT framework (paper 5) proposes a process for conducting these exploration activities in sprints, if you will, within the domain of IoT. At the same time, the self-assessment framework (paper 6) proposes a process to be utilised throughout the maturity stages to evaluate the existing technological capabilities relative to their potential capability level in the pursuit of generating value from the unexploited potential of existing assets. Additionally, the use of well-known tools from the lean toolbox in the frameworks from this research phase will, in all probability, provide a fundamental understanding of existing processes to be utilised in changing the operational design according to the circular principles that are not limited to IoT based solutions, as is also argued in recent literature (Adler et al., 2009; Tortorella & Fettermann, 2018). Lastly, if pursuing product take-back, the process in the IoT framework (paper 5) may be utilised to uncover certain costs and value propositions within the take-back system, according to the factors identified in paper 4.

After the publication of paper 5, the framework was utilised, in collaboration with a Danish RTO, in two additional industrial cases, both being Danish manufacturing SMEs such as those represented in paper 2. As proposed in paper 2 the manufacturers should perceive the introduction of IoT according to the CE context to elevate the technology from its operational perspective. Therefore, in phase 3 of the framework,

the SMEs were explicitly considering both short-term and long-term future scenarios, during which we engaged freely in the discussion concerning the links between IoT and CE. This resulted in the following list, Table 7.2, of desired improvement goals that consist of both short-term and long-term goals.

Table 7.2 List of desired improvement goals at a case company

Desired improvement goals
Reduce the amount of time used for troubleshooting when at customers
Reduce the number of cases where parts are ordered while being at the customer
Increase our ability to resolve concerns (i.e. first-time visiting customers)
Increase the number of cases where we proactively replace spare parts
Increase up-time / reduce down-time
Maintenance and investment forecasting (EoL)
Straight information flow from the customer to the technician
Strengthen challenges with warranty claims (usage history anchored in date)

This explicit emphasis on both short and long-term improvement goals meant that the design of the actual IoT solution could consider the present use case and future use-cases, e.g. by generating expected relevant data for enabling these. As such, the subsequent evaluation of the solution was affected by the definition of long-term improvement goals, as the short-term business case received reduced attention while the long-term and more strategic potentials gained a say in the decision.

If considering the complementary value of the two frameworks (papers 5 and 6), the self-assessment framework (paper 6) holds potential if used in the continuation of the IoT framework (paper 5). The logic behind Figure 7.1 – that technology holds a capability level spanning across different digital maturity levels – may be linked to the improvement goals such as those in Table 7.2, enabling the discussion of the capability levels of IoT technology concerning the desired goals. Accordingly, organisations that engage in these activities can combine the two frameworks in exploring the potentials of IoT in existing operations, evaluating the scoped IoT solutions according to the capability potentials, and continuously self-assessing the realised capability level of present technology to its capability potential and the scoped improvement goals.

CHAPTER 8. DISCUSSION

This dissertation aims at providing the reader with an understanding of the structural elements of the twin transformation, along with insights into how these can be utilised in driving the transformation in organisations to foster sustained competitive advantages in the changing industrial context. Additionally, the dissertation aims to provide the reader with operational frameworks and guidelines for supporting their engagement with the twin transformation. This research project was motivated by academic curiosity and the need to provide insights for the reflective practitioner.

The novelty and contribution of the dissertation and its appended papers to the body of knowledge in the operations management domain concern its ambition to create knowledge while solving practical problems (Boer et al., 2015) while acknowledging the importance of contextualisation that is extensively discussed within this research community (Sousa & Voss, 2008). The dissertation contains a catalogue of contributions related to the early-stage engagement of the transformation, emphasising the initiation of the transformation and aligning the two constituent constructs of the twin transformation.

Contribution	Calls for research
According to the systems perspective, it supports the definition of contextual transformation strategies through a deeper and more nuanced understanding of the structural elements in the twin transformation and their interdependencies. Developing frameworks in papers 3, 5, and 6.	The lack of frameworks to guide the digital (Büyüközkan & Göçer, 2018) and circular (Nobre & Tavares, 2021) transformation.
Contextualising the interdependencies of barriers for CE transformation. Exploring the synergetic role of IoT and CE in the twin transformation. Explicating organisational dimensions and maturity levels of CE transformation.	The lack of knowledge concerning how to address technical and processual barriers, e.g. how to design processes according to CE principles using digital technologies (Abdul-Hamid et al., 2020).
Explicating and structuring the factors influencing the financial feasibility of product take-back systems.	The lack of knowledge concerning the financial feasibility of CE initiatives, e.g. product take-back (Abdul-Hamid et al., 2020; Sepúlveda-Rojas & Benitez-Fuentes, 2016).

Furthermore, the research project aims at relieving the practitioners of the challenges they experience in this agenda. For example, while the European Commission is promoting the twin transformation as a strategic lever in their growth strategy (European Commission, 2022), organisations are challenged in building sustained performance improvements from their engagement in the digital transformation (de la Boutetière et al., 2018). From the CE perspective, Danish manufacturers are found to be at an immature level of engagement in which they have only adopted simple and isolated circular processes, while they are yet to engage in more mature processes that require greater systemic changes to their operational design (ATV, 2022). To enable and nudge manufacturers in their twin transformation engagement, we, as researchers, have an obligation to develop frameworks that meet the managers where they are (Kierkegaard, 1948) in transformational maturity. At such early stages of the transformation, the creation of rhetoric relevance is paramount in creating awareness of the agenda and providing the manager with a language enabling them to spread the awareness of the agenda internally and externally. In the IFN project, we heard this multiple times as a benefit for managers in engaging with academia, as they would acquire a “digital imagination” from the awareness creation that would allow them to “learn to talk industry 4.0” in their organisation. Furthermore, conceptual and instrumental relevance is central in providing schemes and concepts enabling explorative activities. For example, the systemic emphasis unfolded in paper 3 is required for manufacturers to expand their perception of the agenda to be more than a series of technologies utilised in pursuing the CE principles. Instead, there is a need to address the softer dimensions (De Jesus & Mendonça, 2018) of the transformation, e.g. the governance of how to organise resources in the exploration and exploitation of the agenda, in challenging the cultural lock-in from the linear economy.

The choice of adopting mixed method principles is deduced from the research study’s motivation and the academic and industrial calls for research. The methodological choices each have implications for the overarching research project, as each methodology brings its strengths while imposing its weaknesses. Considering the robustness of the research activities, it is worthwhile to consider that this dissertation comprises a mixture of empirically based and conceptual research activities. All empirical cases are Danish manufacturers that, while varying in size, are all operating in the business-to-business market through a product-oriented business model, in which they are selling medium and high-value mechanical or mechatronic products. While this improves the robustness and generalisability for this specific type of manufacturer, it is limited to this type. For the conceptual research activities, the robustness is limited by its lack of empirical foundation or testing. On the other hand, the conceptual nature allows for more creativity and freedom for the researcher, as the findings of potential empirical cases have not limited us. Considering the empirical cases utilised throughout this dissertation, we can speculate that the development of frameworks (e.g. papers 3 and 6) would look different if they were developed based on the engagement and findings from these, e.g. due to their immaturity in the twin transformation agenda, and their limited representation of the broader industrial landscape.

CHAPTER 9. CONCLUSION

In this research project, I have had the opportunity to investigate, both empirically and through desk research, the engagement of Danish manufacturers in the twin transformation agenda (Phase 1), the structural elements of the CE and propose guiding frameworks accordingly (Phase 2), and how managers can explore and exploit IoT in the pursuit of CE principles (Phase 3). The research activities I have engaged in, with close colleagues, over the course of three years have provided us with great insights into these topics, to which we have contributed to the body of knowledge through the papers appended to this dissertation. Accordingly, with the appended papers, the objectives defined for this research project are achieved, as elaborated hereafter.

Objective 1: An understanding of the structural elements of the twin transformation and how they can be utilised to drive the transformation to build a competitive advantage in the changing industrial context.

Objective 2: Frameworks and guidelines for supporting the successful engagement with the twin transformation.

All the appended papers in this dissertation tap into objective 1 as they directly provide insights into the twin transformation's structural elements, the structural elements of the CE, or the IoT agendas. Paper 1 and 2, from the first research phase, provide empirical insights into how manufacturers engage in the twin transformation, including the synergetic relation between the two constituting constructs, which in this study are operationalised as IoT capabilities and CE principles. Additionally, they provide insights into how a Danish manufacturer experiences the dependencies among the barriers to circular transformation. Research phase two provides a systemic perspective on the structural elements of the transformation, focusing on the CE agenda through the development of a maturity reference model, a comprehensive overview of the factors influencing the financial performance of product take-back, and methodological reflections of the process for contextualising the barriers for transforming. Lastly, research phase three deep dives into the processual perspective of exploring and exploiting IoT in pursuing circular principles.

All appended papers address objective 2; however, they vary in how explicitly they do so. Research phase 2 and 3 are very explicit in this, as the appended paper 1, 3, 5, and 6 all propose frameworks for supporting managers in engaging (i.e. designing, exploring and exploiting) into the twin transformation, either at the organisational level or at more narrow process-oriented levels. At more implicit levels, appended papers 1, 2, and 4 from research phases 1 and 2 provide insights that guide the manager

conceptually or rhetorically in their engagement with the agenda. These papers provide propositions for the relation between IoT and CE, dependencies between barriers for the CE transformation, and factors for incorporating in designing financially viable product take-back systems.

Accordingly, change is needed at all three economic levels for manufacturers to become truly immersed in the twin transformation agenda, as presented in Figure 1.2. To foster the systemic change required, the agenda's strategic presence must increase at institutional levels (macro economy level) to nudge and enable manufacturers to adopt its principles. At the meso economy level, the inadequate infrastructure constraints manufacturers in effectively and efficiently operating circular processes that require the physical and digital moving of products, materials, and information. Lastly, and most relevant to this research study, is the microeconomic level at which substantial change is required to facilitate the systematic industrial transformation. Manufacturers are stuck in a linear lock-in affecting their decision-making process, operations design, and perception of business value propositions accordingly. The organisational governance is currently not supportive of explorative activities that move beyond a certain threshold, i.e. they stick to small incremental improvements. Accordingly, there is a need to translate incremental improvement into genuine innovation. The closed improvement process is not likely to bring systematic innovation unless this is taken into account during the scoping and the process of these initiatives, where opportunity scouting, multidisciplinary stakeholder involvement, experimental behaviour etc., becomes a natural element in development initiatives. As such, manufacturers must encourage explorative activities according to the novel agendas while investing in new competencies internally or externally to mitigate the introduction of novel and diverse mindsets. For this, there is a need to encourage the systems perspective to move beyond the low-hanging fruits of simple and isolated improvement initiatives. To facilitate such change, the perception of business value and the evaluation of such, e.g. in business cases, are required to let go of the traditional 2-year business case format, as the need for establishing enabling infrastructure may not be profitable when perceived in an isolated manner. Instead, investments should be evaluated according to long-term strategic ambitions (Colli et al., 2021a; Lassen & Waehrens, 2021).

9.1. LIMITATIONS AND FUTURE RESEARCH

This dissertation presents the research activities conducted during the past three years. These activities, along with the appended papers, are subject to limitations that guide the formulation of proposals for future research.

In relation to assessing the external validity, which refers to the applicability of conclusions in contextual settings (Karlsson, 2010), the conducted research activities are subject to limitations, specifically from the perspective of ecological validity, a subset of the external validity. As discussed in Chapter 8, all empirical cases utilised throughout this research project are similar. Therefore, it is questionable whether the findings

of this research are generalisable across empirical cases that are contextually different. Accordingly, replicating the studies in contextually different cases is needed to strengthen the external validity. Until then, and even after, we must be aware of the contextual settings in which the evidence exists and how these influence the research findings.

This research project concerns a transformation agenda in its very early stages, meaning the domain's paradigms are yet to be fully established (Pagoropoulos et al., 2017). As such, the empirical cases utilised throughout the project consist of manufacturers interested and engaged in the agenda, while they are all at a relatively low maturity level – as is the general level of maturity across the industry (ATV, 2022). Accordingly, the propositions made concerning the synergetic relation between IoT and CE over time (paper 2), along with the mid-high maturity levels in the proposed maturity model (paper 3), contain a great deal of uncertainty as they are made according to the beliefs of the managers in the empirical cases (paper 2) along with the insights from the existing knowledge base for defining the maturity levels (paper 3). Accordingly, future research should adopt a longitudinal methodology, e.g., investigating the relationship between the IoT and the CE principles in uncovering the synergies that enable managers to progress further in the agenda.

Lastly, the contributions of this research project that originated from desk research (papers 3, 4, and 6) are subject to limitations from their lacking testing in empirical cases. Empirical tests of these contributions would allow us to gain insights into, e.g. the criticality of the individual factors affecting the financial performance of the product take-back system for the contexts in which the findings are tested. Furthermore, the contextual dependencies between factors can be tested using similar methodologies as we deployed in paper 1. Finally, empirical testing of the frameworks (papers 3 and 6) is needed to argue for their actual instrumental relevance, i.e. to answer whether they are acting as scaffolding in guiding organisations in designing their transformation. As such, the call for further research is to test the robustness of the conceptual foundation of these studies.

LITERATURE LIST

- Abdul-Hamid, A., Ali, M. H., Tseng, M., Lan, S., & Kumar, M. (2020). Impeding challenges on industry 4.0 in circular economy: Palm oil industry in Malaysia. *Computers & Operations Research*, 123, 105052.
- Adler, P. S., Benner, M., Brunner, D. J., MacDuffie, J. P., Osono, E., Staats, B. R., Takeuchi, H., Tushman, M., & Winter, S. G. (2009). Perspectives on the productivity dilemma. *Journal of Operations Management*, 27(2), 99-113.
- Agyemang, M., Kusi-Sarpong, S., Khan, S. A., Mani, V., Rehman, S. T., & Kusi-Sarpong, H. (2019). Drivers and barriers to circular economy implementation. *Management Decision*, 10.1108/MD-11-2018-1178
- Alamerew, Y. A., & Brissaud, D. (2020). Modelling reverse supply chain through system dynamics for realizing the transition towards the circular economy: A case study on electric vehicle batteries. *Journal of Cleaner Production*, 254, 120025. 10.1016/j.jclepro.2020.120025
- Atasu, A., & Van Wassenhove, L. N. (2012). An operations perspective on product take-back legislation for e-waste: Theory, practice, and research needs. *Production and Operations Management*, 21(3), 407-422. 10.1111/j.1937-5956.2011.01291.x
- ATV. (2022). *Fremtidens bæredygtige produktion*. (). Copenhagen, Denmark:
- Ayati, M. S., Shekarian, E., Majava, J., & Wæhrens, B. V. (2022). Toward a circular supply chain: Understanding barriers from the perspective of recovery approaches. *Journal of Cleaner Production*, 359, 131775.
- Bell, E., Harley, B., & Bryman, A. (2022). *Business research methods*. Oxford university press.
- Bernstein, E. S. (2012). The transparency paradox: A role for privacy in organizational learning and operational control. *Administrative Science Quarterly*, 57(2), 181-216.
- Berzi, L., Delogu, M., Pierini, M., & Romoli, F. (2016). Evaluation of the end-of-life performance of a hybrid scooter with the application of recyclability and recoverability assessment methods. *Resources, Conservation and Recycling*, 108, 140-155.
- Bjerre, M., & Parbo, N. (2021). *Looping on data*. (). Denmark: Danish Business Authority.
- Blackburn, J. D., Guide Jr, V Daniel R, Souza, G. C., & Van Wassenhove, L. N. (2004). Reverse supply chains for commercial returns. *California Management Review*, 46(2), 6-22. 10.2307/41166207
- Bocken, N. M., De Pauw, I., Bakker, C., & Van Der Grinten, B. (2016). Product design and business model strategies for a circular economy. *Journal of Industrial and Production Engineering*, 33(5), 308-320.
- Bockholt, M. T., Kristensen, J. H., Colli, M., Jensen, P. M., & Wæhrens, B. V. (2020). Exploring factors affecting the financial performance of end-of-life take-back program in a discrete manufacturing context. *Journal of Cleaner Production*, 258, 120916. 10.1016/j.jclepro.2020.120916

- Boer, H. (2004). Continuous innovation: En udfordring og et dilemma. In J. Johansen, & J. O. Riis (Eds.), *Fremtidens produktion i Danmark: Antologi* (pp. 221). Dansk Industri.
- Boer, H., & Duing, W. E. (2001). Innovation, what innovation? A comparison between product, process and organizational innovation. *International Journal of Technology Management*, 22(1-3), 83-107.
- Boer, H., Holweg, M., Kilduff, M., Pagell, M., Schmenner, R., & Voss, C. (2015). Making a meaningful contribution to theory. *International Journal of Operations & Production Management*,
- Boulding, K. E. (1966). The economics of the coming spaceship earth. *New York*, , 1-17.
- Brinker, S. (2013). Martec's Law: Technology changes exponentially, organizations change logarithmically. *Chiefmartec Website* < [https://ChiefMartec.Com/2013/06/Martec Cslaw-Techn Ology-Chang Es-Expon Entia Lly-Organ Izati Ons-Chang E-Logar Ithmi Cally](https://ChiefMartec.Com/2013/06/Martec%20Law-Technology-Change-Exponential-Organizational-Change),
- Büyükoçkan, G., & Göçer, F. (2018). Digital supply chain: literature review and a proposed framework for future research. *Computers in Industry*, 97, 157-177.
- Caffyn, S. (1999). Development of a continuous improvement self-assessment tool. *International Journal of Operations & Production Management*, 19(11), 1138-1153. 10.1108/01443579910291050
- Checkland, P. (1999). Systems thinking. *Rethinking Management Information Systems*, , 45-56.
- Cohen, Y., Naseraldin, H., Chaudhuri, A., & Pilati, F. (2019). Assembly systems in Industry 4.0 era: a road map to understand Assembly 4.0. *The International Journal of Advanced Manufacturing Technology*, 105(9), 4037-4054.
- Colli, M., Madsen, O., Berger, U., Møller, C., Wæhrens, B. V., & Bockholt, M. (2018). Contextualizing the outcome of a maturity assessment for Industry 4.0. *Ifac-Papersonline*, 51(11), 1347-1352.
- Colli, M., Berger, U., Bockholt, M., Madsen, O., Møller, C., & Wæhrens, B. V. (2019). A maturity assessment approach for conceiving context-specific roadmaps in the Industry 4.0 era. *Annual Reviews in Control*, 48, 165-177.
- Colli, M., Stingl, V., & Waehrens, B. V. (2021a). Making or breaking the business case of digital transformation initiatives: the key role of learnings. *Journal of Manufacturing Technology Management*,
- Colli, M., Uhrenholt, J. N., Madsen, O., & Waehrens, B. V. (2021b). Translating transparency into value: an approach to design IoT solutions. *Journal of Manufacturing Technology Management*,
- Corbett, C., & Van Wassenhove, L. (1993). Trade-offs? What trade-offs? Competence and competitiveness in manufacturing strategy. *California Management Review*, 35(4), 107-122.
- Creswell, J. W., Plano Clark, V. L., Gutmann, M. L., & Hanson, W. E. (2003). Advanced mixed methods research designs. *Handbook of Mixed Methods in Social and Behavioral Research*, 209(240), 209-240.
- Croom, S. (2010). Introduction to research methodology in operations management. *Researching operations management* (pp. 56-97). Routledge.

- Crosby, P. B. (1979). *Quality is free: The art of making quality certain*. McGraw-hill New York.
- Davies, R. (2015). Industry 4.0: Digitalisation for productivity and growth.
- De Jesus, A., & Mendonça, S. (2018). Lost in transition? Drivers and barriers in the eco-innovation road to the circular economy. *Ecological Economics*, 145, 75-89.
- de la Boutetière, H., Montagner, A., & Reich, A. (2018, Oct 29,). Unlocking success in digital transformations. *McKinsey Insights*, <https://search.proquest.com/docview/2372144073>
- Denyer, D., & Tranfield, D. (2009). Producing a systematic review.
- Dreyfus, H. L., & Dreyfus, S. E. (2005). Peripheral vision: Expertise in real world contexts. *Organization Studies*, 26(5), 779-792.
- Dunning, D. (2011). The Dunning–Kruger effect: On being ignorant of one's own ignorance. *Advances in experimental social psychology* (pp. 247-296). Elsevier.
- Elrod, P. D., & Tippett, D. D. (2002). The “death valley” of change. *Journal of Organizational Change Management*,
- Erkman, S. (1997). Industrial ecology: an historical view. *Journal of Cleaner Production*, 5(1-2), 1-10.
- European Commission. (2020). *Circular Economy Action Plan : For a cleaner and more competitive Europe*. ().European Commission. <https://library.wur.nl/WebQuery/groenekennis/2290762>
- European Commission. (2022a). *Horizon Europe – Twin green and digital transition*. Retrieved 27-07-2022, from <https://www.welcomeurope.com/en/the-list-of-our-calls-projects/horizon-europe-twin-green-and-digital-transition-2021/>
- European Commission. (2022b). *TWIN GREEN AND DIGITAL TRANSITION 2021*. European Commission. Retrieved 01-07-2022, from <https://ec.europa.eu/info/funding-tenders/opportunities/portal/screen/opportunities/topic-details/horizon-cl4-2021-twin-transition-01-12>
- Fenn, J., & Time, M. (2007). Understanding Gartner's hype cycles, 2007. *Gartner ID G*, 144727
- Fine, C. H., & Whitney, D. E. (2002). Is the make-buy decision process a core competence?
- Ford, H., & Crowther, S. (1922). *My life and work*. Doubleday, Page.
- Gartner. (2022). *What Is Data and Analytics?* Gartner. Retrieved 02-03-2022, from <https://www.gartner.com/en/topics/data-and-analytics>
- Gold, S., Schodl, R., & Reiner, G. (2017). Cumulative manufacturing capabilities in Europe: Integrating sustainability into the sand cone model. *Journal of Cleaner Production*, 166, 232-241.
- Greene, J. C., & Caracelli, V. J. (1997). *Advances in mixed-method evaluation: The challenges and benefits of integrating diverse paradigms*. Jossey-Bass,.
- Guldmann, E., & Huulgaard, R. D. (2020). Barriers to circular business model innovation: A multiple-case study. *Journal of Cleaner Production*, 243, 118160.

- Haddud, A., DeSouza, A., Khare, A., & Lee, H. (2017). Examining potential benefits and challenges associated with the Internet of Things integration in supply chains. *Journal of Manufacturing Technology Management*, 28(8), 1055-1085.
- Harland, T. (2003). Vygotsky's zone of proximal development and problem-based learning: Linking a theoretical concept with practice through action research. *Teaching in Higher Education*, 8(2), 263-272.
- He, Z., & Wong, P. (2004). Exploration vs. exploitation: An empirical test of the ambidexterity hypothesis. *Organization Science*, 15(4), 481-494.
- Holmström, J., Ketokivi, M., & Hameri, A. (2009). Bridging practice and theory: A design science approach. *Decision Sciences*, 40(1), 65-87.
- Hvass, K. K., & Pedersen, E. R. G. (2019). Toward circular economy of fashion: Experiences from a brand's product take-back initiative. *Journal of Fashion Marketing and Management: An International Journal*, 10.1108/JFMM-04-2018-0059
- Ingemarsdotter, E., Jamsin, E., Kortuem, G., & Balkenende, R. (2019). Circular strategies enabled by the internet of things—A framework and analysis of current practice. *Sustainability*, 11(20), 5689.
- Jensen, S. F., Kristensen, J. H., Uhrenholt, J. N., Rincón, M. C., Adamsen, S., & Waehrens, B. V. (2022). Unlocking Barriers to Circular Economy: An ISM-Based Approach to Contextualizing Dependencies. *Sustainability*, 14(15), 9523.
- Jick, T. D. (1979). Mixing qualitative and quantitative methods: Triangulation in action. *Administrative Science Quarterly*, 24(4), 602-611.
- Johansen, J., Riis, J. O., & Arlbjørn, J. S. (2006). Analyse og design af produktionssystemer:-med vægt på styring og organisering.
- Kagermann, H. (2015). Change through digitization—Value creation in the age of Industry 4.0. *Management of permanent change* (pp. 23-45). Springer.
- Karlsson, C. (2010). Researching operations management. *Researching operations management* (pp. 20-55). Routledge.
- Kierkegaard, S. (1948). *Synspunktet for min forfattervirksomhed: en ligefrem meddelelse. Rapport til historien*. Wivel.
- Kirchherr, J., Piscicelli, L., Bour, R., Kostense-Smit, E., Muller, J., Huibrechtse-Truijens, A., & Hekkert, M. (2018). Barriers to the circular economy: Evidence from the European Union (EU). *Ecological Economics*, 150, 264-272.
- Kjaer, L. L., Pigosso, D. C., Niero, M., Bech, N. M., & McAloone, T. C. (2019). Product/service-systems for a circular economy: The route to decoupling economic growth from resource consumption? *Journal of Industrial Ecology*, 23(1), 22-35.
- Konietzko, J., Bocken, N., & Hultink, E. J. (2020). A tool to analyze, ideate and develop circular innovation ecosystems. *Sustainability*, 12(1), 417.
- Kristoffersen, E., Blomsma, F., Mikalef, P., & Li, J. (2020). The smart circular economy: A digital-enabled circular strategies framework for manufacturing companies. *Journal of Business Research*, 120, 241-261.
- Kumar, V., Shirodkar, P. S., Camelio, J. A., & Sutherland, J. W. (2007). Value flow characterization during product lifecycle to assist in recovery decisions. *International Journal of Production Research*, 45(18-19), 4555-4572.

- Kumar, V., Sezersan, I., Garza-Reyes, J. A., Gonzalez, E. D., & Moh'd Anwer, A. (2019). Circular economy in the manufacturing sector: benefits, opportunities and barriers. *Management Decision*,
- Lahti, T., Wincent, J., & Parida, V. (2018). A definition and theoretical review of the circular economy, value creation, and sustainable business models: where are we now and where should research move in the future? *Sustainability*, *10*(8), 2799.
- Larsen, M. S. S., Magnusson, M., & Lassen, A. H. (2021). Industry 4.0 Holds a Great Potential for Manufacturers, So Why haven't They Started? *Towards Sustainable Customization: Bridging Smart Products and Manufacturing Systems* (pp. 721-729). Springer.
- Lassen, A. H., & Waehrens, B. V. V. (2021). Labour 4.0: developing competences for smart production. *Journal of Global Operations and Strategic Sourcing*,
- Laudan, L. (1978). *Progress and its problems: Towards a theory of scientific growth*. Univ of California Press.
- Leitz, R., Solti, A., Weinhard, A., & Mendling, J. (2018). Adoption of RFID Technology: The Case of Adler—A European Fashion Retail Company. In J. vom Brocke, & J. Mendling (Eds.), *Business Process Management Cases* (pp. 449-461). Springer.
- Lewis, M. W. (1998). Iterative triangulation: a theory development process using existing case studies. *Journal of Operations Management*, *16*(4), 455-469.
- Li, F. (2020). Leading digital transformation: three emerging approaches for managing the transition. *International Journal of Operations & Production Management*,
- Li, S., Xu, L. D., & Zhao, S. (2015). The internet of things: a survey. *Information Systems Frontiers*, *17*(2), 243-259.
- Lieder, M., & Rashid, A. (2016). Towards circular economy implementation: a comprehensive review in context of manufacturing industry. *Journal of Cleaner Production*, *115*, 36-51.
- Links, P. (2013). *Emerging trends in global advanced manufacturing*. (No. 12). Cambridge, United Kingdom: United Nations Industrial Development Organization.
- Lu, Y., Papagiannidis, S., & Alamanos, E. (2018). Internet of Things: A systematic review of the business literature from the user and organisational perspectives. *Technological Forecasting and Social Change*, *136*, 285-297.
- Martinez, F. (2019). Process excellence the key for digitalisation. *Business Process Management Journal*,
- McCutcheon, D. M., & Meredith, J. R. (1993). Conducting case study research in operations management. *Journal of Operations Management*, *11*(3), 239-256.
- McDonough, W., & Braungart, M. (2010). *Cradle to cradle: Remaking the way we make things*. North point press.
- Merli, R., Preziosi, M., & Acampora, A. (2018). How do scholars approach the circular economy? A systematic literature review. *Journal of Cleaner Production*, *178*, 703-722. 10.1016/j.jclepro.2017.12.112

- Meudt, T., Metternich, J., & Abele, E. (2017). Value stream mapping 4.0: Holistic examination of value stream and information logistics in production. *CIRP Annals*, 66(1), 413-416.
- Mittal, S., Khan, M. A., Romero, D., & Wuest, T. (2018). A critical review of smart manufacturing & Industry 4.0 maturity models: Implications for small and medium-sized enterprises (SMEs). *Journal of Manufacturing Systems*, 49, 194-214. 10.1016/j.jmsy.2018.10.005
- Moeuf, A., Pellerin, R., Lamouri, S., Tamayo-Giraldo, S., & Barbaray, R. (2018). The industrial management of SMEs in the era of Industry 4.0. *International Journal of Production Research*, 56(3), 1118-1136.
- Møller, C., Hansen, A. K., Palade, D., Sørensen, D. G. H., Hansen, E. B., Uhrenholt, J. N., & Larsen, M. S. S. (2022a). *Innovation Factory North - An Approach to Make Small and Medium Sized Manufacturing Companies Smarter*. Unpublished manuscript.
- Møller, C., Hansen, A. K., Palade, D., Sørensen, D. G. H., Hansen, E. B., Uhrenholt, J. N., & Larsen, M. S. S. (2022b). *Researching Small and Medium-sized Enterprises: An action Design Research Approach to study Digital Transformation in SME*. Unpublished manuscript.
- Moore, G. E. (1998). Cramming more components onto integrated circuits. *Proceedings of the IEEE*, 86(1), 82-85.
- Morlet, A., Blériot, J., Opsomer, R., Linder, M., Henggeler, A., Bluhm, A., & Carrera, A. (2016). Intelligent assets: Unlocking the circular economy potential. *Ellen MacArthur Foundation*, , 1-25.
- Mykhaylenko, A., Waehrens, B. V., & Slepnirov, D. (2017). The impact of distance on headquarters' network management capabilities. *Journal of Manufacturing Technology Management*,
- Nicolai, A., & Seidl, D. (2010). That's relevant! Different forms of practical relevance in management science. *Organization Studies*, 31(9-10), 1257-1285.
- Niero, M., & Rivera, X. C. S. (2018). The role of life cycle sustainability assessment in the implementation of circular economy principles in organizations. *Procedia CIRP*, 69, 793-798.
- Nobre, G. C., & Tavares, E. (2017). Scientific literature analysis on big data and internet of things applications on circular economy: a bibliometric study. *Scientometrics*, 111(1), 463-492.
- Nobre, G. C., & Tavares, E. (2021). The quest for a circular economy final definition: A scientific perspective. *Journal of Cleaner Production*, , 127973.
- Nolan, R. L. (1979). Managing the crises in data processing. *Harvard Business Review*, 57(2), 115-116. <http://search.ebscohost.com/login.aspx?direct=true&db=buh&AN=3867671&site=ehost-live>
- Nygaard, J., Colli, M., & Wæhrens, B. V. (2020). A self-assessment framework for supporting continuous improvement through IoT integration. *Procedia Manufacturing*, 42, 344-350.
- Ollagnier, J. M., Brueckner, M., Berjoan, S., & Dijkstra Sytze. (2020). *The European Double Up: A twin strategy that will strengthen competitiveness*. (). <https://www.accenture.com/us-en/insights/strategy/european-double-up>

- Ormazabal, M., Prieto-Sandoval, V., Puga-Leal, R., & Jaca, C. (2018). Circular economy in Spanish SMEs: challenges and opportunities. *Journal of Cleaner Production*, 185, 157-167.
- Pagoropoulos, A., Pigosso, D. C., & McAloone, T. C. (2017). The emergent role of digital technologies in the Circular Economy: A review. *Procedia CIRP*, 64, 19-24.
- Papachroni, A., Heracleous, L., & Paroutis, S. (2015). Organizational ambidexterity through the lens of paradox theory: Building a novel research agenda. *The Journal of Applied Behavioral Science*, 51(1), 71-93.
- Pauli, G. A. (2010). *The blue economy: 10 years, 100 innovations, 100 million jobs*. Paradigm publications.
- Pelz, D. C. (1978). Some expanded perspectives on use of social science in public policy. *Major Social Issues: A Multidisciplinary View*,
- Pieroni, M. P., McAloone, T. C., & Pigosso, D. C. (2019). Business model innovation for circular economy and sustainability: A review of approaches. *Journal of Cleaner Production*, 215, 198-216.
- Pigosso, D. C., & McAloone, T. C. (2021). Making the transition to a circular economy within manufacturing companies: the development and implementation of a self-assessment readiness tool. *Sustainable Production and Consumption*,
- Prozman, E. J., & Wæhrens, B. V. (2019). Managing waste quality in industrial symbiosis: Insights on how to organize supplier integration. *Journal of Cleaner Production*, 234, 113-123.
- Rajput, S., & Singh, S. P. (2020). Industry 4.0 model for circular economy and cleaner production. *Journal of Cleaner Production*, 277, 123853. 10.1016/j.jclepro.2020.123853
- Ramakrishna, S., Ngowi, A., Jager, H. D., & Awuzie, B. O. (2020). Emerging industrial revolution: Symbiosis of Industry 4.0 and circular economy: The role of universities. *Science, Technology and Society*, 25(3), 505-525.
- Ramsheva, Y. K., Prozman, E. J., & Wæhrens, B. V. (2019). Dare to make investments in industrial symbiosis? A conceptual framework and research agenda for developing trust. *Journal of Cleaner Production*, 223, 989-997.
- Rejeb, A., Suhaiza, Z., Rejeb, K., Seuring, S., & Treiblmaier, H. (2022). The Internet of Things and the circular economy: A systematic literature review and research agenda. *Journal of Cleaner Production*, , 131439.
- Rosa, P., Sassanelli, C., Urbinati, A., Chiaroni, D., & Terzi, S. (2020). Assessing relations between Circular Economy and Industry 4.0: A systematic literature review. *International Journal of Production Research*, 58(6), 1662-1687.
- Rüßmann, M., Lorenz, M., Gerbert, P., Waldner, M., Justus, J., Engel, P., & Harnisch, M. (2015). Industry 4.0: The future of productivity and growth in manufacturing industries. *Boston Consulting Group*, 9(1), 54-89.
- Sacco, P., Vinante, C., Borgianni, Y., & Orzes, G. (2021). Circular Economy at the Firm Level: A New Tool for Assessing Maturity and Circularity. *Sustainability*, 13(9), 5288.
- Sahi, G. K., Gupta, M. C., & Cheng, T. (2020). The effects of strategic orientation on operational ambidexterity: A study of indian SMEs in the industry 4.0 era. *International Journal of Production Economics*, 220, 107395.

- Scheffer, C., & Girdhar, P. (2004). *Practical machinery vibration analysis and predictive maintenance*. Elsevier.
- Sepúlveda-Rojas, J. P., & Benitez-Fuentes, P. A. (2016). Coordination and return uncertainties in closed loop supply chains. Paper presented at the *2016 6th International Conference on Computers Communications and Control (ICCCC)*, 188-195. 10.1109/ICCCC.2016.7496759
- Shokouhyar, S., Pahlevani, N., & Sadeghi, F. M. M. (2019). Scenario analysis of smart, sustainable supply chain on the basis of a fuzzy cognitive map. *Management Research Review*,
- Singh, J., & Ordoñez, I. (2016). Resource recovery from post-consumer waste: important lessons for the upcoming circular economy. *Journal of Cleaner Production*, 134, 342-353. 10.1016/j.jclepro.2015.12.020
- Singh, R., & Bhanot, N. (2020). An integrated DEMATEL-MMDE-ISM based approach for analysing the barriers of IoT implementation in the manufacturing industry. *International Journal of Production Research*, 58(8), 2454-2476.
- Sousa, R., & Voss, C. A. (2008). Contingency research in operations management practices. *Journal of Operations Management*, 26(6), 697-713.
- Stentoft, J., & Rajkumar, C. (2018). Balancing theoretical and practical relevance in supply chain management research. *International Journal of Physical Distribution & Logistics Management*,
- Taherdoost, H. (2016). Sampling methods in research methodology; how to choose a sampling technique for research. *How to Choose a Sampling Technique for Research (April 10, 2016)*,
- Tan, J., Tan, F. J., & Ramakrishna, S. (2022). Transitioning to a Circular Economy: A Systematic Review of Its Drivers and Barriers. *Sustainability*, 14(3), 1757.
- Toffel, M. W. (2016). Enhancing the practical relevance of research. *Production and Operations Management*, 25(9), 1493-1505.
- Tortorella, G. L., & Fettermann, D. (2018). Implementation of Industry 4.0 and lean production in Brazilian manufacturing companies. *International Journal of Production Research*, 56(8), 2975-2987.
- Tukker, A. (2004). Eight types of product–service system: eight ways to sustainability? Experiences from SusProNet. *Business Strategy and the Environment*, 13(4), 246-260.
- Uhrenholt, J. N., Kristensen, J. H., Adamsen, S., Jensen, S. F., Colli, M., & Waehrens, B. V. (2022a). Twin Transformation: Synergies between Circular Economy and Internet of Things– A study of Danish Manufacturers. *[Manuscript Submitted for Publication]*,
- Uhrenholt, J. N., Kristensen, J. H., Rincón, M. C., Adamsen, S., Jensen, S. F., & Waehrens, B. V. (2022b). Maturity Model as a Driver for Circular Economy Transformation. *Sustainability*, 14(12), 7483.
- Uhrenholt, J. N., Kristensen, J. H., Rincón, M. C., Jensen, S. F., & Waehrens, B. V. (2022c). Circular economy: Factors affecting the financial performance of product take-back systems. *Journal of Cleaner Production*, 335, 130319. <https://doi.org/10.1016/j.jclepro.2021.130319>

- Ünal, E., & Shao, J. (2019). A taxonomy of circular economy implementation strategies for manufacturing firms: Analysis of 391 cradle-to-cradle products. *Journal of Cleaner Production*, 212, 754-765.
- Urbinati, A., Franzò, S., & Chiaroni, D. (2021). Enablers and Barriers for Circular Business Models: an empirical analysis in the Italian automotive industry. *Sustainable Production and Consumption*, 27, 551-566.
- Van Aken, J., Chandrasekaran, A., & Halman, J. (2016). Conducting and publishing design science research: Inaugural essay of the design science department of the Journal of Operations Management. *Journal of Operations Management*, 47, 1-8.
- Veile, J. W., Kiel, D., Müller, J. M., & Voigt, K. (2019). Lessons learned from Industry 4.0 implementation in the German manufacturing industry. *Journal of Manufacturing Technology Management*.
- Wee, D., Kelly, R., Cattell, J., & Breunig, M. (2015). *Industry 4.0 How to navigate digitization of the manufacturing sector*. ().McKinsey Digital. <https://www.mckinsey.com/~media/McKinsey/Business%20Functions/Operations/Our%20Insights/Industry%2040%20How%20to%20navigate%20digitization%20of%20the%20manufacturing%20sector/Industry-40-How-to-navigate-digitization-of-the-manufacturing-sector.ashx>
- Wendler, R. (2012). The maturity of maturity model research: A systematic mapping study. *Information and Software Technology*, 54(12), 1317-1339. 10.1016/j.infsof.2012.07.007
- Wernerfelt, B. (1984). A resource-based view of the firm. *Strategic Management Journal*, 5(2), 171-180.
- Wu, L., Yue, X., Jin, A., & Yen, D. C. (2016). Smart supply chain management: a review and implications for future research. *The International Journal of Logistics Management*.
- Yuan, Z., Bi, J., & Moriguchi, Y. (2006). The circular economy: A new development strategy in China. *Journal of Industrial Ecology*, 10(1-2), 4-8.
- Zhu, S., Song, J., Hazen, B. T., Lee, K., & Cegielski, C. (2018). How supply chain analytics enables operational supply chain transparency. *International Journal of Physical Distribution & Logistics Management*, 48(1), 47-68.

APPENDICES

- Paper 1.** Jensen, S. F., Kristensen, J. H., Uhrenholt, J. N., Rincón, M. C., Adamsen, S., & Waehrens, B. V. (2022). Unlocking barriers to circular economy: An ISM-based approach to contextualizing dependencies. *Sustainability*, 14(15), 9523.
- Paper 2.** Uhrenholt, J. N., Kristensen, Colli, M., & Waehrens, B. V. (2022a). Twin Transformation: Synergies between Circular Economy and Internet of Things– A study of Danish Manufacturers. In Review
- Paper 3.** Uhrenholt, J. N., Kristensen, J. H., Rincón, M. C., Adamsen, S., Jensen, S. F., & Waehrens, B. V. (2022b). Maturity Model as a Driver for Circular Economy Transformation. *Sustainability*, 14(12), 7483.
- Paper 4.** Uhrenholt, J. N., Kristensen, J. H., Rincón, M. C., Jensen, S. F., & Waehrens, B. V. (2022c). Circular economy: Factors affecting the financial performance of product take-back systems. *Journal of Cleaner Production*, 335, 130319.
- Paper 5.** Colli, M., Uhrenholt, J. N., Madsen, O. and Waehrens, B.V. (2021b). Translating transparency into value: an approach to design IoT solutions. *Journal of Manufacturing Technology Management*, Vol. 32 No. 8, pp. 1515-1532
- Paper 6.** Nygaard, J., Colli, M., & Wæhrens, B. V. (2020). A self-assessment framework for supporting continuous improvement through IoT integration. *Procedia Manufacturing*, Vol. 42, pp. 344-350.

ISSN (online): 2446-1636
ISBN (online): 978-87-7573-807-6

AALBORG UNIVERSITY PRESS