

## Terminal-embedded beamforming for wireless local area networks

Lu, Chenguang; Fitzek, Frank; Eggers, Patrick Claus F.; Jensen, Ole Kiel; Pedersen, Gert Frølund; Larsen, Torben

*Published in:*  
IEEE Wireless Communications

*DOI (link to publication from Publisher):*  
[10.1109/MWC.2008.4492981](https://doi.org/10.1109/MWC.2008.4492981)

*Publication date:*  
2008

*Document Version*  
Early version, also known as pre-print

[Link to publication from Aalborg University](#)

*Citation for published version (APA):*  
Lu, C., Fitzek, F., Eggers, P. C. F., Jensen, O. K., Pedersen, G. F., & Larsen, T. (2008). Terminal-embedded beamforming for wireless local area networks. *IEEE Wireless Communications*, 15(2), 82-91.  
<https://doi.org/10.1109/MWC.2008.4492981>

### General rights

Copyright and moral rights for the publications made accessible in the public portal are retained by the authors and/or other copyright owners and it is a condition of accessing publications that users recognise and abide by the legal requirements associated with these rights.

- Users may download and print one copy of any publication from the public portal for the purpose of private study or research.
- You may not further distribute the material or use it for any profit-making activity or commercial gain
- You may freely distribute the URL identifying the publication in the public portal -

### Take down policy

If you believe that this document breaches copyright please contact us at [vbn@aub.aau.dk](mailto:vbn@aub.aau.dk) providing details, and we will remove access to the work immediately and investigate your claim.

# Terminal-Embedded Beamforming for Wireless Local Area Networks

Chenguang Lu, Frank H.P. Fitzek, Patrick C.F. Eggers, Ole Kiel Jensen, Gert F. Pedersen, and  
Torben Larsen

† Aalborg University, Department of Electronic Systems,

Niels Jernes Vej 12, DK-9220 Aalborg East, Denmark, E-mail: [cgl,ff,pe,okj,gfp,tl]@es.aau.dk

## Abstract

In dense traffic areas, wireless local area networks (WLANs) suffer from interference problems due to congestion of the open and unlicensed ISM band. To mitigate these problems, a terminal-embedded beamforming framework is proposed — this beamforming is capable of focusing the transmission and the reception in the direction of the relevant access point. At the same time the framework is backward compatible with existing WLAN networks. The beamforming enabled terminal benefits in terms of capacity, security, and energy efficiency while not requiring any changes on the network side costing network providers new investments. The beamforming solution is seen as an attractive value-added feature as well as low cost solution for the future WLAN terminal design. This opens the door for mobile device manufacturers to include the proposed solution into their product line. In this work, the backwards compatibility challenges are addressed and some possible solutions and the limitations are discussed. Also shown is a prototype design built on a laptop computer. The experimental results show a significant capacity increase in both an interference free scenario and an interference limited scenario

## I. INTRODUCTION

In the last years the deployment of wireless local area networks (WLANs<sup>1</sup>) has increased dramatically. The WLAN technology has found its way into the home, office and public domain (hotels, restaurants, airports etc.). Nowadays, almost every larger terminal, i.e. laptop computers, and even some small terminals such as smart-phones, has built-in WLAN capability. Since the technology has improved in the area of security, and since different business models have shown their strength, WLAN is now offered by most of the wireless network providers. Even though WLAN is now offering data rates of hundreds of megabits per second (Mbps), the offered capacity is often not enough in multi-user scenarios. And this can not even be compensated by the installation of more access points. The only limiting factor for mass usage of WLAN at the moment is the pricing policy of the network providers. In places where access is granted for free, such as in the office or in some conference centers, the capacity per user is sometimes not even sufficient to run the basic services such as virtual private networks (VPNs). This observation will probably also hold for the aforementioned WLAN networks of the network providers, if wireless flat rates are introduced as known in the wired world.

The interference problem is a major contributor to the limited capacity of WLANs. First, the WLAN spectrum is located within the congested unlicensed ISM band which is subject to interference from other communication systems such as Bluetooth and DECT (Digital Enhanced Cordless Telecommunications). Second, due to the lack of available spectrum, the frequency reuse is so frequent that it causes severe co-channel interference problems in dense traffic areas. This is usually referred to as the hidden nodes problem [7] in WLAN which degrades network capacity. Third, the MAC layer of WLAN can not solve the hidden nodes problem in the co-channel interference scenario, though it can be well solved by using the request to send / clear to send (RTS/CTS) [1] mechanism in a single hotspot scenario. This is referred to as the large interference range problem [8].

Interference problem can be greatly mitigated in the spatial domain by utilizing multiple antenna techniques. We classify the multiple antenna techniques into two classes, (i) signal space techniques and (ii) beam space techniques. Signal space techniques defines a class of techniques (e.g. MIMO (Multiple Input Multiple Output), time reversal, diversity combining techniques) that need the instantaneous channel state information (CSI) of each transmitting-receiving antennas pair at the receiver end and even at the both ends. However, beam space techniques, usually referred as beamforming techniques, do not require the instantaneous CSI and instead rely on some average metrics, such as signal strength measurements. In this context, beamforming means the capability of steering a directive beam in the relevant direction of the intended transmitter or receiver. As signal space techniques may require new signaling to obtain the needed CSI, beam space techniques are possible to be transparent to the existing standards and networks. To be noted, interferences can be also mitigated with single antenna interference cancellation (SAIC) techniques in the time domain (see e.g. [4]). As SAIC works for specific systems and special types of interferences, multiple antenna techniques are capable of suppressing all kinds of interferences in the spatial domain.

The goal of this work is primarily to demonstrate the potential capacity increase by providing a beamforming

<sup>1</sup>In this paper, WLAN refers to the IEEE 802.11 infra-structured wireless local area network.

capability at the wireless terminal. Current research on beamforming in WLANs focuses on the access point — see e.g. [9], [10]. Although this is a most relevant issue, the present work aims at providing beamforming capabilities at the wireless terminal to ensure backwards compatibility with existing WLAN networks. This also avoids any force on changes in existing wireless networks causing new investments for the network providers. Furthermore, providing terminal beamforming may be attractive for manufacturers of WLAN terminals as the customers will benefit from higher data rates. This is discussed in further detail in the following section.

The paper is organized as follows. Section II gives an overview of beamforming techniques and describes the benefits of terminal beamforming. Section III presents the challenges for implementing terminal beamforming being backwards compatible to the existing WLAN networks and discusses the limitations and possible solutions. In Section IV, a prototype demonstrator design is presented as an implementation example to show the concept. Section V presents the experimental setup and the experimental results. Finally, the conclusions are presented in Section VI.

## II. OVERVIEW OF TERMINAL BEAMFORMING

Multiple antenna techniques have been obtained a lot of attentions in recent years as they have a great potential to increase data rate significantly. From the architecture point of view, there are three categories of techniques referred as MIMO, MISO (Multiple Input Single Output), and SIMO (Single Input Multiple Output) techniques. The first requires multiple antennas at both ends of a communication link. The latter two only requires multiple antennas at either the transmitter side (MISO) or the receiver side (SIMO). As a illustration, Fig. 1 shows the examples of the above three systems.

The typical representatives of MIMO techniques are BLAST-type MIMO (VBLAST or DBLAST), space-time coding, and eigenbeamforming, which are all considered in the next generation of WLAN — 802.11n standards (MIMO WLAN) [3]. They are doing the spatial multiplexing allowing the simultaneous transmission of multiple streams. Multiple transceiver chains are normally needed at both ends and thereby it increases the power consumption, complexity, and costs.

As a typical MISO/SIMO technique, a beamforming system works as a linear spatial filter that is capable of forming a directive beam to the relevant direction. It can significantly increase link capacity by exploiting beam diversity and interference suppression. From the architecture point of view, a beamforming system can be regarded as a single antenna system with a directional antenna. Therefore, differently from MIMO techniques, beamforming techniques can be transparently included as an add-on in single antenna systems without major modifications to the existing systems. This will significantly reduce the cost of the new system design by reusing the existing transceiver structure. To be noted, space-time coding can be also used in MISO systems. However, space-time coding transmits different symbols at different antennas at the same time and thereby requires a new space-time decoding algorithm implemented in receiver. Therefore, it is not transparent to the existing single antenna transceivers.

Although the MIMO WLAN is being standardized [3], the success of the new standards is still not clear for now. First, the evolution time will be rather long before the costs of MIMO systems are reduced to a low level.

Second, the major problem of WLAN networks is not in data rate but the interference problem as the current WLAN standards can already provide very high data rate up to 54 Mbps. Therefore, the purely spatial-multiplexing MIMO networks will still suffer by the interference problem. Third, full benefits of MIMO systems can be only exploited with the network support. For a great number of the existing worldwide deployed legacy WLAN networks, a MIMO terminal has to be switched back to the legacy standards. Before the MIMO networks are widely deployed, users are not willing to pay for a technique without the network support.

Therefore, in this paper, we focus on beamforming techniques which are applied at the terminal side to be transparent to the existing WLAN networks. We will show that it is possible for a low cost solution of terminal beamforming to obtain a number of advantages but still being backward compatible with existing wireless networks. To make it clear, the beamforming can also be implemented with a MIMO transceiver structure as it is originally designed for MIMO systems. But such a solution will cost more than a solely beamforming design.

In the following, the potential benefits of terminal beamforming are described. Observe that the reference case mentioned is the present situation using fixed omnidirectional antenna patterns in the wireless terminals. The benefits of terminal beamforming are:

- 1) **Capacity increase:** Utilizing the focused beam improves the link budget by focusing the transmission and the reception in the relevant direction while reducing the interference transmitted to or received from other directions. The increased signal-to-interference-plus-noise ratio (SINR) increases the uplink and downlink capacity of the beamforming enabled terminal. For uplink, it comes only from the improved signal quality at the access point by directive transmission. For downlink, it can also come from the interference suppression capability of the beamforming. Furthermore, the beamforming also benefits the other nodes in the network. The nodes that are not in the beam pointing direction will get less interference from the beamforming terminal's transmission. Practically, in WLAN, the capacity increase is achieved by the data rate increase due to the data rate adaptation used which can dynamically adjust the data rate according to the quality of the channel state by changing the modulation constellation and the coding rate [1].
- 2) **Security:** Security in WLAN systems was very weak in the first generations of WLAN but the situation has fortunately improved in the newer generations [2]. However, the first step for any intruder is always to look for the physical signal. By utilizing beamforming the possibility of signal interception is reduced and gives less chance to the intruder to even know that a communication is taking place. As data rate is increased by using beamforming, it is more difficult for the radio hacker out of the beam location to decode the higher data rate information with lower received signal power. Therefore, By having directive antenna beams, radio hacking is much more difficult to perform — hence an increase in security level. This can be further improved by letting the network hop between access points making it even more difficult for hackers to have access to the radio signals.
- 3) **Energy Efficiency:** WLAN user terminals are usually battery powered. Therefore, the energy efficiency is sometimes very important. Energy efficiency is measured by energy consumption per bit. For a low loss passive beamformer that consumes almost no power, the energy efficiency improvement is achieved by the increased

data rate. For a given time with the same power consumption, the beamforming terminal can accomplish more traffic due to the higher data rate and thereby improve the energy efficiency. Even for an active beamformer that consumes power, the energy efficiency improvement can be still achieved with a low power consumption beamformer design due to the increased data rate.

### III. BACKWARDS COMPATIBILITY CHALLENGES

#### A. MAC protocol challenges

To achieve the backward compatibility with existing WLANs, the terminal beamforming should be compliant with the WLAN MAC protocol. The IEEE 802.11 WLAN MAC protocol [1] coordinates the transmissions in a hotspot (the service area of an access point) in such a way that only one transmission is allowed at a time. Otherwise, collisions occur which degrades the capacity. Two coordination functions have been defined: (i) a Distributed Coordination Function (DCF), and (ii) a Point Coordination Function (PCF). DCF is the dominating factor in practice. For all the centralized MAC protocols like PCF, there is no problem for terminals to direct the beam to the access point all the time as the transmissions are coordinated by the access point. The following focus on the DCF for the terminal beamforming.

The DCF uses a carrier sense multiple access / collision avoidance (CSMA/CA) protocol [1]. Generally, each node senses the channel to determine if the channel is busy or idle before a transmission. The channel sensing is performed until the channel is sensed idle. Then the transmission is deferred by a random backoff time. After the random backoff, the second round channel sensing is performed over a short period of time. The transmission is performed if the channel is sensed idle again. If it is sensed busy, then the process iterates back to the first round channel sensing. The channel sensing before the random backoff can be performed in two ways — either physically or virtually. The second round channel sensing is performed physically. The physical channel sensing is performed by measuring the received signal strength over a short period of time, and comparing the signal strength to a predefined threshold. If the signal strength is higher, the channel is determined busy. Otherwise, it is determined idle. The virtual channel sensing is performed by the exchange of the short control packets, RTS/CTS (request to send / clear to send). A node first transmits the RTS to the receiving node to indicate the duration of the intended transmission before the data transmission. Then the receiving node replies the CTS carrying the requested transmission duration information to inform other nodes. After getting the CTS, the node starts to perform the data transmission. Other nodes who receive the RTS or CTS would defer their transmission attempts until the reserved transmission duration has expired.

Using terminal beamforming in transmission is in conflicts with the physical channel sensing. First, the beamforming terminal may not sense the transmissions from the directions in the sidelobe of the beam. Second, the directive beamforming transmission may not be sensed by other nodes. In either case, it causes the collision problem between beamforming enabled terminals and other nodes degrading the capacity.

1) *A solution:* The problem can be solved by using the hybrid antenna pattern manipulation with the virtual channel sensing [5]. The basic idea is that the physical channel sensing and the RTS transmission are performed

with an omnidirectional pattern or antenna while the data transmission is performed with a directive beam pattern after receiving the CTS. As a result, the omnidirectional physical channel sensing makes sure that the beamforming enabled terminal can 'hear' the transmissions of the other nodes before a transmission attempt and therefore would not interfere other nodes in the hotspot, while the RTS is protected by the omnidirectional transmission from being interfered by other nodes. After completion of the RTS/CTS process, the time slots for the directive beamforming transmission are reserved for a transmission without collisions from the other nodes in the hotspot.

### *B. Beam steering challenges*

In real environments, in order to achieve the benefits of terminal beamforming, a beam steering algorithm should be implemented to track the time variance of the channel. Direction finding is generally the first step for the beam steering. Lack of the instantaneous CSI gives the difficulties and limitations to perform direction finding. Direction finding can not be achieved on packet-by-packet level based on the preamble of each packet. Therefore, it needs to seek help from the other packets from the access point. The possible candidates are beacons, CTS packets and the packets sent to other terminals. Therefore, a fast direction finding algorithm is needed to accomplish the direction finding within the period of the candidate packets. In WLAN networks, beacons come every about 100 millisecond. Therefore, the direction finding based on beacons can update at about 10 Hz. Furthermore, beacons are transmitted at the lowest data rate. It is possible to design a direction finding algorithm that does not affect the successful reception of beacons. Especially for downlink, the robustness can be further obtained by utilizing the existing diversity antenna switch that can switch between two antennas to achieve switch diversity on packet-by-packet level. In this case, we can let it switch between a omnidirectional state and a beamforming state. It will make a solution always not worse than the single antenna case. For uplink, it should always use the latest direction finding result. In the case the direction finding updating speed can not catch up with the channel varying, the beamforming system should switch back to the omnidirectional antenna state.

## IV. A PROTOTYPE DEMONSTRATOR DESIGN

The following presents a fairly low complexity prototype demonstrator design. The demonstrated beamforming system is based on a simple switched beam system. However, the focus has been on demonstrating the principle and the design is not optimized in any way. To make it clear, the MAC scheme and the fast direction finding algorithm described in Section III are not implemented.

The prototype should allow comparison of two situations: (i) a standard reference situation using omni-directional antennas, and (ii) a beamforming enabled situation. The block diagram for the concept is shown in Fig. 2. The demonstration system is working at RF as an add-on to a standard WLAN card. As shown in Fig. 2, the built-in diversity switch is disabled, and the RF front-end connects directly to the demonstration system. Furthermore, the demonstration system can switch between the reference antenna system path and the beamforming system path. It is designed in such a way that the total transmitted power is the same for the two systems to be compared, thus making a fair comparison. The RF phased array architecture is applied in the beamforming system design. It is

basically composed of an antenna array, phase shifters, and a power splitter. The beamforming is controlled through the control interface by changing the phase shifting of each phase shifter. The benefit of this design is that it can be achieved at low power consumption and costs, as proposed recently in an RF IC (integrated circuit) form by [11], [12].

A real demonstrator on a laptop computer running Linux operating system has been built as shown in Fig. 3. The hardware of the demonstration system is composed of four parts: an antenna array on the top of the laptop lid, a phase shifter board (including a four-branch phase shifter with a power splitter, and a switch between the beamforming system and the reference system), control interface, and a modified WLAN card<sup>2</sup>. The capacity comparison can be made when it is switched between the beamforming system and the reference system. The RF front-end of the WLAN card is connected to the phase shifter board. A control software in the laptop computer runs a beamforming algorithm by varying the phase shifting of the phase shifters and perform the switching between two systems to be compared by transmitting the control information from the parallel port to the control interface.

#### A. Antenna array

As shown in Fig. 3, six antenna elements are placed linearly with about  $0.4\lambda$  spacing, where  $\lambda$  is the wavelength at 2.4 GHz, on the top of the laptop computer lid. The central four out of six antenna elements are used to form a four-element uniform linear array (ULA). The other two elements are used as dummy elements<sup>3</sup>. The leftmost element in Fig. 3 is also used as the reference system antenna.

A PIFA-like (planar inverted f-antenna) edge-mounted antenna is used as the antenna element of the ULA which gives a rather omnidirectional pattern for vertical polarization in the horizontal plane — as shown in the imposed image in the top right corner of Fig. 3<sup>4</sup>. The cross polarization discrimination (XPD) of the antenna elements for the demonstrator design is about 0 dB.

#### B. Phase shifter design

The main part of the phase shifter board is a four-branch phase shifter. For the prototype design, a four-bit switched microstrip delay line phase shifter is used in each branch. Since the phase shifters are passive and therefore has some loss, an attenuator is also included in the reference system path to balance the transmission power. The four-bit phase shifter is designed to give 16 phase shift states with 22.5 degrees phase step from 0 degree to 337.5 degree.

<sup>2</sup>A 3COM WLAN card, model: 3CRWE154G72. It is modified so that its RF front end can be connected to an external antenna. The choice of this card was based on the accessibility of the necessary RF signals, switches etc. to interface with the demonstration system.

<sup>3</sup>Dummy elements are included in the demonstrator design to ensure edge elements to have similar loading effects as middle elements. This allows simple array manipulations with approximately the same element patterns. For a real implementation, the elements could be designed individually to take care of this.

<sup>4</sup>The three-dimensional dual polarized patterns of individual antenna elements were measured with the entire antenna array subsystem in an anechoic room at Aalborg University. When one antenna element was measured, the other elements were terminated with standard 50 ohm loads. Therefore, the measurement included the effects from other antenna elements (i.e. mutual coupling). The imposed antenna pattern in the top right corner of Fig. 3 is the measured pattern in the horizontal plane of the reference system antenna element



For manufacturing and other practical reasons, the actual phase shift is slightly higher than the designed. However, the phase shift error is acceptable for the beamforming steering application as shown by the measured beams in Fig. 4.

### C. Beamformer and beam selection

Only a small subset of all possible beams were chosen to find the relevant direction, as the nine beams shown in Fig. 4. Therefore, the beamforming system is a nine beam switching system. Fig. 4 also shows the ideal demonstrator beams for the comparison purpose. The measured demonstrator beams are synthesized using the measured antenna element patterns and the measured phase shifting states. The ideal demonstrator beams are synthesized using ideal omnidirectional antenna element patterns and the measured phase shifting states. The beam spacing for the ideal demonstrator beams is about the half the beamwidth of an adjacent beam as we expect that the unique beams can be achieved by a half beam width spacing [6], [14]. For vertical polarization, it is seen that the mainlobe of the measured beams are quite similar to the ideal ones, and the sidelobes have bigger differences. It may be because of the imperfect omnidirectional behavior of the antenna element pattern, the mutual coupling effects, and other practical issues. To be noted, in practice, the vertical polarization is usually dominated in WLAN environments due to the widely usage of the vertical polarized antennas at the access point side, which is also the case in the experiment described later. Therefore, the above beamforming setup will be valid for the experimental concept verifications.

### D. Control software

The control software implements a simple beam selection algorithm to perform direction finding that scans the nine beam patterns one by one. It chooses the best one with the highest measured average signal strength. In practice, the signal strength can be measured very fast in hardware. With fast switching circuits, the above direction finding algorithm can complete in a very short period within a short packet period such as a beacon. However, in demonstration, the signal strength is simply obtained by querying the statistics data from the WLAN card driver<sup>5</sup>. The querying frequency can be set up to 100 Hz. The duration on each beam pattern can also be changed in the software. The control software also acts as a monitoring tool. The graphic user interference (GUI) is shown in Fig. 5. It shows the information on the signal strength (in dBm), the data rate (in Mbps), and the TCP throughput (in Mbps), as shown in Figure 5. Then the performance comparison between the beamforming system and the reference system can be easily seen in the GUI.

<sup>5</sup>As there is no available Linux driver for the WLAN card used, it was chosen to use the ndiswrapper driver in Linux, which is a wrapper around Windows XP drivers to make these executable in Linux.

## V. EXPERIMENT SETUP AND SOME RESULTS

### A. Experiment setup

To compare the performance of the beamforming system and the reference system in a real environment, the experiment was made with the demonstrator in a laboratory area at Aalborg University, Denmark, as shown in Fig. 6. This area is a typical office environment. The experiment used two access points<sup>6</sup>, namely AP1 and AP2, covering the laboratory area. The distance between AP1 and AP2 is large enough so that they can not sense the transmissions from each other. And they are working in the same frequency channel centered at 2.437 GHz (channel 6). As shown in Fig. 6, the experiment was performed at 10 locations, namely L1-L10. The signal strength measurements and the effective throughput measurements were done for the beamforming case and the reference case at each location. For the beamforming case, the scanning duration on each beam pattern is set 0.5 second, about 5 beacon periods, and therefore the total scanning time is 4.5 seconds to determine the best beam direction. The signal strength (in dBm) were recorded for 10 seconds with the best beam at each location. The signal strength results are the average value over 10 seconds. The effective throughput measurement were done to show the real downlink throughput by recording the downloading time of an about 40 Megabytes file. The effective throughput was then calculated as (file size)/(downloading time). The experiment was done in a weekend without people walking around while the nearby university WLAN networks were shutted down. As signal strength was observed fairly stable during the measurement at each location, we can regard the channel as a reasonably static channel during each measurement. Two scenarios were considered in the measurements:

- 1) Interference free scenario: Only AP1 was turned on. The measurement results were collected in the reference case and the beamforming case.
- 2) A downlink interference scenario: AP1 and AP2 were both turned on. The effective throughput measurements were done with AP1 while an interfering downlink traffic from AP2 to the other standard terminal, T2, as shown in Fig. 6, were going on. To link the effective throughput to the average signal-to-interference ratio (SIR), we also did the signal strength measurement solely for T1 with AP1 and AP2 with the beam used in the effective throughput measurements, while shutting off the interference link from AP2 to T2. Then the average SIR (in dB) was calculated as the difference of the measured signal strength results from AP1 and the measured signal strength results from AP2 at each location.

### B. Some results

The experimental results at the 10 locations are given in Table I. The reference system and the beamforming system are compared with the measured signal strength, SIR, and effective throughput. Furthermore, the signal strength gain and the SIR gain of the beamforming system over the reference system are given in dB while the effective throughput gain is given in both Mbps and in percent. In the interference free scenario, the beamforming system always provides higher signal strength than the reference system while at 9 of 10 locations the beamforming

<sup>6</sup>Cisco Aironet 1100 Series wireless access points.

system significantly improves effective throughput (up to 59%). The signal strength gain fluctuates from 2.6 dB to 9 dB, which comes from the beam diversity. In average, the beamforming system provides 5.1 dB signal strength gain and 2.3 Mbps (22%) improvement in effective throughput. The average signal strength gain is close to 6 dB, the maximum array gain of a four-element antenna array. It indicates that the indoor propagation even in non-line-of-sight (NLOS) scenario is fairly concentrated within the beam width of the beams such that the most of multipaths power are captured by the directive beam. The similar experimental observations can be also seen in [9], [13]. Therefore, we conclude that the beamforming systems can provide the power gain in indoor environments due to the high directivity of the indoor propagation channel. However, if the beam is so narrow that the beam gain can not compensate the power loss of the multipaths out of the beam, using the beam will get less power than using omnidirectional antenna.

In the interference scenario, the effective throughput is significantly reduced comparing to the interference free scenario due to the downlink interference from AP2 to T2. The beamforming system provided higher SIR at 9 out of 10 locations while at all locations the beamforming system offered significant effective throughput increase (up to 393%). In average, the beamforming system provides 6.8 dB gain in SIR and 2.5 Mbps (137%) improvement in effective throughput. The extra gain in SIR compared to the signal strength gain in interference free scenario is achieved by the interference reduction when the interference comes to the sidelobe of the beam.

To be noted, the experiments show only the downlink case. For uplink, the link capacity is increased only from the power gain. The signal strength gain and SIR gain results in uplink would be similar to the downlink results in the interference free scenario.

## VI. CONCLUSIONS

This work proposes a terminal implemented beamforming framework for WLAN terminal design which is backward compatible with existing WLAN networks. An implementation example is given by a prototype demonstrator design built on a laptop computer, demonstrating significant capacity increase in both a interference free scenario and a interference limited scenario in a typical office environment. The beamforming enabled terminal benefits in terms of capacity, security, energy consumption while not requiring any change on the network side costing network providers the new investments. As network operators are less than willing to invest more money to upgrade their network infrastructure, the terminal manufacturers may want to apply this value-added feature for future WLAN terminals. Thereby providing users with more capacity and longer standby time which are the key factors on users purchase choices.

## ACKNOWLEDGMENT

The authors thank the C3 program initiated by Center for TeleInfrastruktur (CTIF) of Aalborg University, Denmark, for its financial support, and the COGNAC project team (<http://kom.aau.dk/project/cognac>) for their efforts in building the demonstrator.

## REFERENCES

- [1] "Information technology- Telecommunications and information exchange between systems- Local and metropolitan area networks- Specific requirements- Part 11: Wireless LAN Medium Access Control (MAC) and Physical Layer (PHY) Specifications," *ANSI/IEEE Std 802.11, 1999 Edition (R2003)*, pp. i-513, 2003.
- [2] "IEEE Standard for Information technology- Telecommunications and information exchange between systems- Local and metropolitan area networks- Specific requirements Part 11: Wireless LAN Medium Access Control (MAC) and Physical Layer (PHY) specifications Amendment 6: Medium Access Control (MAC) Security Enhancements," *IEEE Std 802.11i-2004*, pp. 0-1-175, 2004.
- [3] S.A. Mujtaba, et al., "TGn sync proposal technical specification," *IEEE 802.11-04/0889r7*, Jul. 2005.
- [4] Z. Zeng, B. Allen, and A.H. Aghvami, "Performance evaluation of a Bluetooth interference canceller in IEEE802.11b wireless networks," *IEEE Trans. on Consum Electr.*, vol. 51, no. 4, pp. 1188-1196, Nov. 2005.
- [5] A. Nasipuri, S. Ye, J. You, and R.E. Hiromoto, "A MAC protocol for mobile ad hoc networks using directional antennas," *Wireless Communications and Networking Conference, 2000. WCNC. 2000 IEEE*, vol. 3, pp. 1214-1219, 2000.
- [6] R.G. Vaughan, "Beam spacing for angle diversity," *Global Telecommunications Conference, 1998. GLOBECOM 98. The Bridge to Global Integration. IEEE*, vol. 2, pp. 928-933, 1998.
- [7] F.A. Tobagi, and L. Kleinrock, "Packet switching in radio channels: the hidden terminal problem in carrier sensing multiple access and busy tone solution," *IEEE Trans. on Commun.*, vol. 23, no. 12, pp. 1417-1433, 1975.
- [8] K. Xu, M. Gerla, and S. Bae, "How effective is the IEEE 802.11 RTS/CTS handshake in ad hoc networks," *Global Telecommunications Conference, 2002. GLOBECOM '02. IEEE*, vol. 1, pp. 72-76, 17-21 Nov. 2002.
- [9] E. Casas, C. Tong, M. da Silva, H. Yin, and Y.-S. Choi, "Beam diversity for indoor WLAN systems," *Vehicular Technology Conference, 2003. VTC 2003-Fall. IEEE 58th*, vol. 5, pp. 3141-3144, 6-9 Oct. 2003.
- [10] J.M. Carey, and D. Grunwald, "Enhancing WLAN security with smart antennas: a physical layer response for information assurance," *Vehicular Technology Conference, 2004. VTC2004-Fall. 2004 IEEE 60th*, vol. 1, pp. 318-320, 26-29 Sept. 2004.
- [11] A. Natarajan, A. Komijani, and A. Hajimiri, "A fully integrated 24-GHz phased-array transmitter in CMOS," *Solid-State Circuits, IEEE Journal of*, vol. 40, no. 12, pp. 2502- 2514, Dec. 2005.
- [12] J. Paramesh, R. Bishop, K. Soumyanath, and D.J. Allstot, "A four-antenna receiver in 90-nm CMOS for beamforming and spatial diversity," *Solid-State Circuits, IEEE Journal of*, vol. 40, no. 12, pp. 2515- 2524, Dec. 2005.
- [13] L.J. Pesik, M.A. Beach, and B.H. Allen, "Performance analysis of switched-sector antennas for indoor wireless LANs," *Vehicular Technology Conference, 2001. VTC 2001-Fall. IEEE 54th*, vol. 1, pp. 358-362, 2001.
- [14] P.C.F. Eggers, "Angular propagation descriptions relevant for base station adaptive antenna operation," *Kluwer: Wireless Personal Communications*, vol. 11, no. 1, pp. 3-29, Oct. 1999.

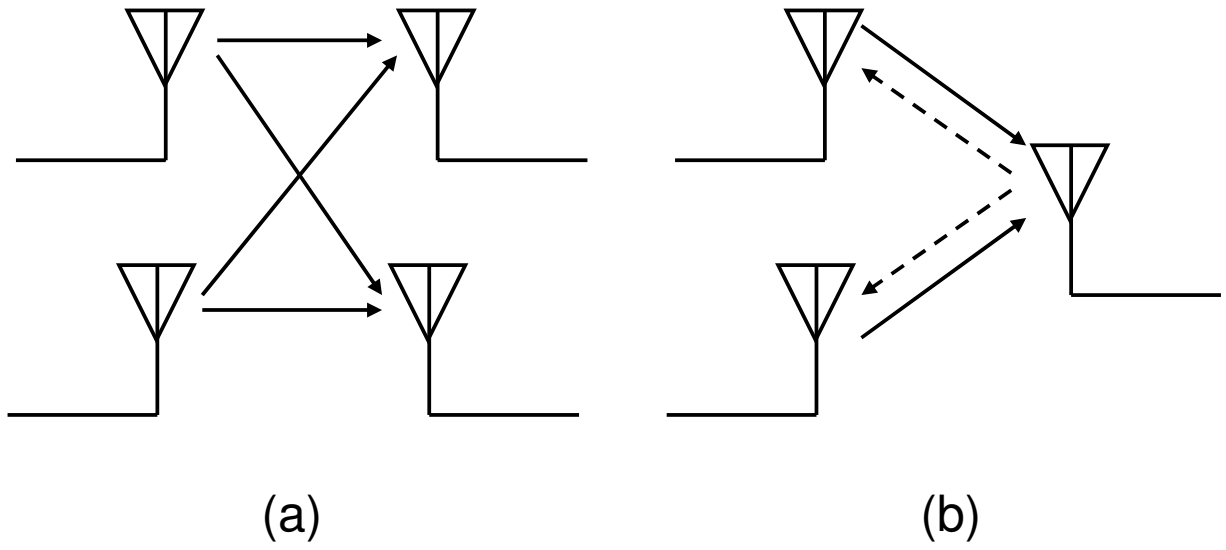

Fig. 1. Examples of MIMO, MISO and SIMO systems. (a) a  $2 \times 2$  MIMO system. (b) solid line represents the transmission direction of a  $2 \times 1$  MISO system and dashed line represents that of a  $1 \times 2$  SIMO system.

TABLE I  
EXPERIMENTAL RESULTS

Location	Interference free scenario				Interference scenario			
	Signal strength		Effective throughput		SIR		Effective throughput	
	Ref. / Beam (dBm)	Gain (dB)	Ref. / Beam (Mbps)	Gain (Mbps / %)	Ref. / Beam (dB)	Gain (dB)	Ref. / Beam (Mbps)	Gain (Mbps / %)
L1	-68 / -62	6	14.5 / 13.8	-0.6 / -4.3%	11.8 / 24	12.2	4.3 / 10.0	5.6 / 131.3%
L2	-72.2 / -69.5	2.7	9.1 / 11.0	1.9 / 20.7%	12.6 / 15.5	2.9	2.4 / 4.1	1.7 / 71.8%
L3	-72 / -68.2	3.8	12.7 / 14.5	1.7 / 13.6%	9.2 / 9.8	0.6	1.7 / 1.8	0.1 / 4.5%
L4	-65.5 / -62	3.5	13.8 / 15.9	2.1 / 15%	18.5 / 21	2.5	4.8 / 5.3	0.5 / 10%
L5	-69.2 / -64.4	4.8	12.2 / 15.2	2.9 / 23.8%	10.8 / 16.6	5.8	2.9 / 4.8	1.9 / 63.6%
L6	-75 / -66	9	9.1 / 14.5	5.4 / 59.1%	3 / 18	15	1.2 / 4.8	3.7 / 312%
L7	-76.7 / -74.1	2.6	9.6 / 10.6	1 / 10%	8 / 6.1	-1.9	0.7 / 1.3	0.6 / 80.7%
L8	-70 / -64	6	13.3 / 15.9	2.7 / 20%	10 / 22	12	2.5 / 6.9	4.4 / 173.9%
L9	-75 / -68	7	9.4 / 12.2	2.9 / 30.8%	0.2 / 15.2	15	1.1 / 5.5	4.4 / 393.1%
L10	-73 / -67.1	5.9	11 / 14.5	3.5 / 31.8%	8 / 11.4	3.4	1.4 / 3.2	1.8 / 124%
Avg.	-71.7 / -66.5	5.1	11.5 / 13.8	2.3 / 22%	9.2 / 16.0	6.8	2.3 / 4.8	2.5 / 137%

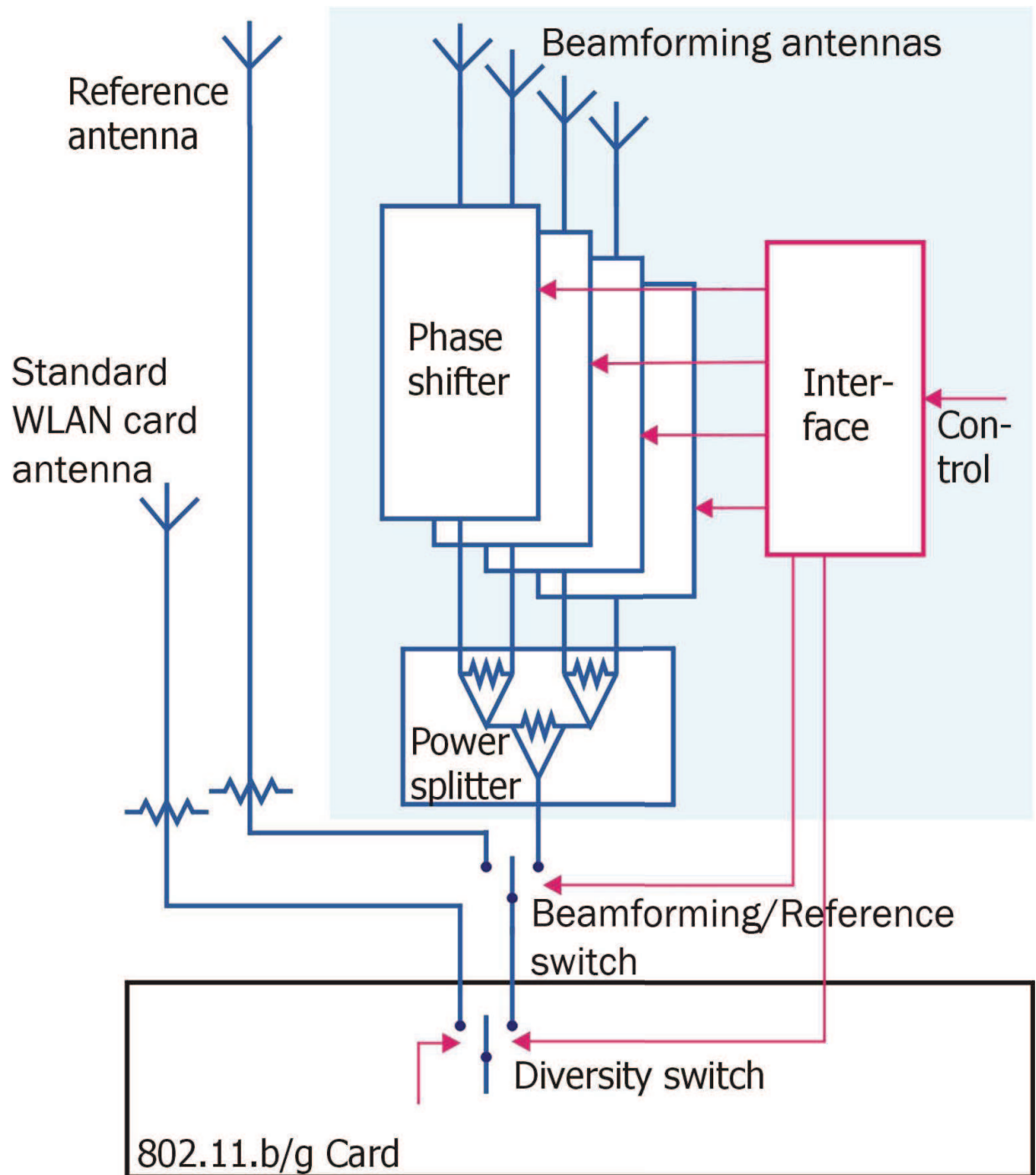

Fig. 2. Block diagram of the demonstration system.

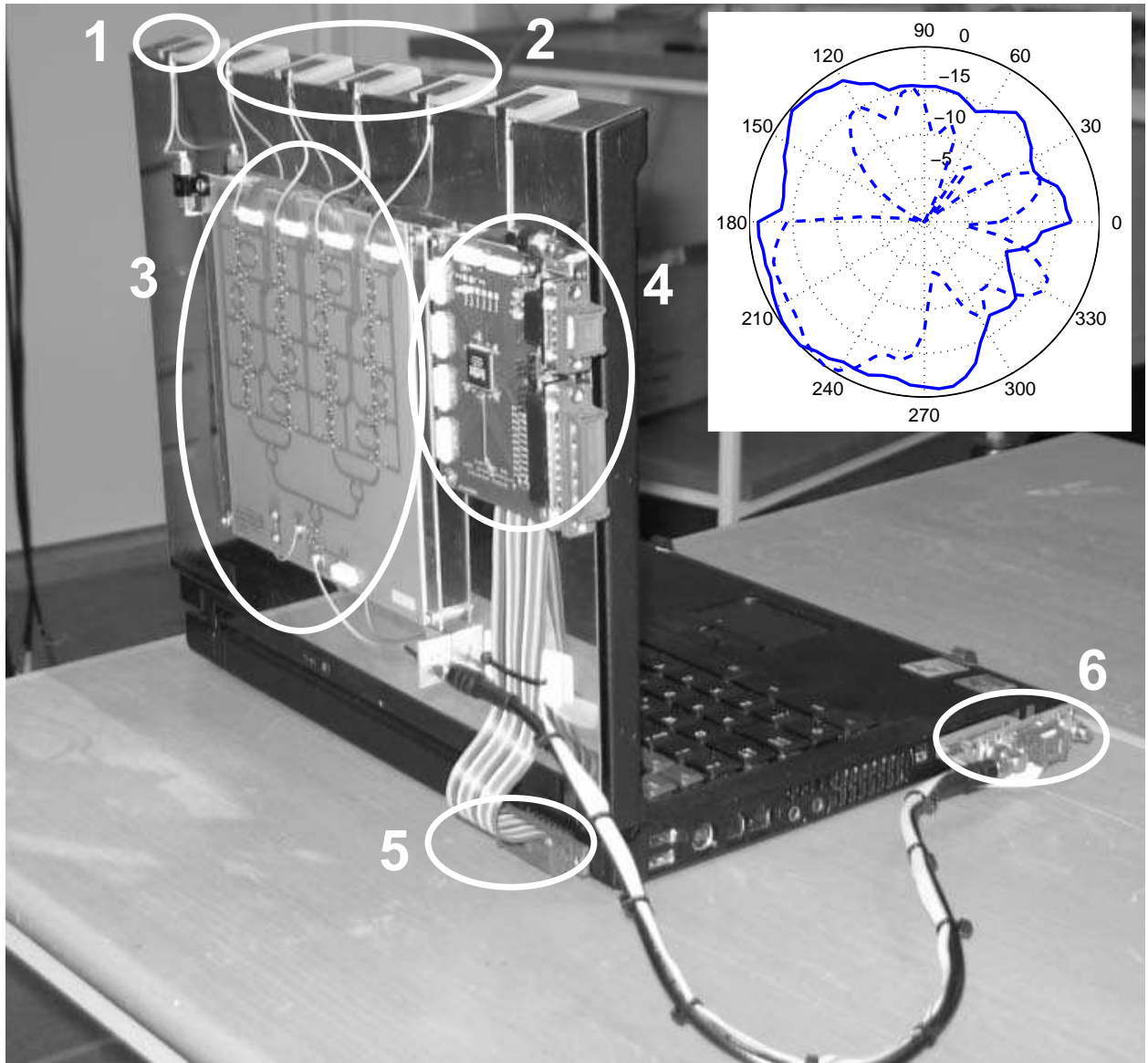

Fig. 3. Photo of the demonstrator. The demonstration system is placed on the back of the laptop computer's lid. 1: reference system antenna, 2: four-element ULA, 3: phase shifter board ((including a four-branch phase shifter with a power splitter, and a switch between the beamforming system and the reference system), 4: control interface, 5: parallel port of laptop computer, 6: modified WLAN card. The measured dual polarized antenna patterns in the horizontal plane of the reference system antenna are imposed in the top right corner (in dB and normalized to their maxima). Solid: vertical polarization, dashed: horizontal polarization.



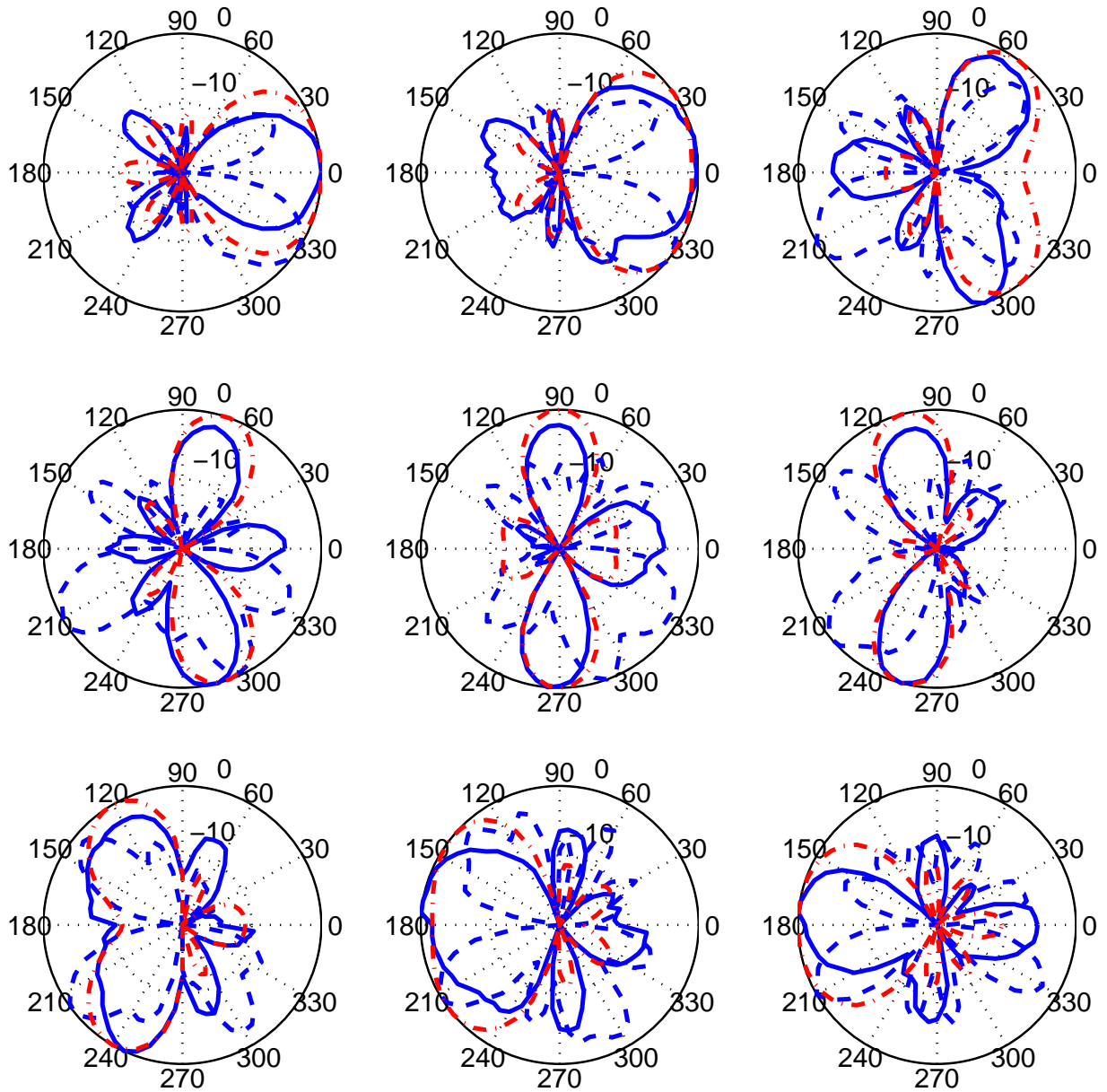

Fig. 4. Measured demonstrator beam patterns (in dB) in the horizontal plane. Solid: the measured vertical polarization beam patterns. Dashed: the measured horizontal polarization beam patterns. Dash-dotted: the ideal demonstrator beam patterns. In order to compare the similarity of the measured beam patterns and the ideal beam patterns, the beam patterns are normalized their own maxima.



Fig. 5. GUI of the control software showing the monitored information in real time. 1: instantaneous signal strength line, 2: average signal strength bar for the reference case, 3: average signal strength bar for the beamforming case, 4: instantaneous data rate line, 5: average data rate bar for the reference case, 6: average data rate bar for the beamforming case, 7: instantaneous TCP throughput, 8: antenna pattern indicator showing the antenna pattern currently being used.

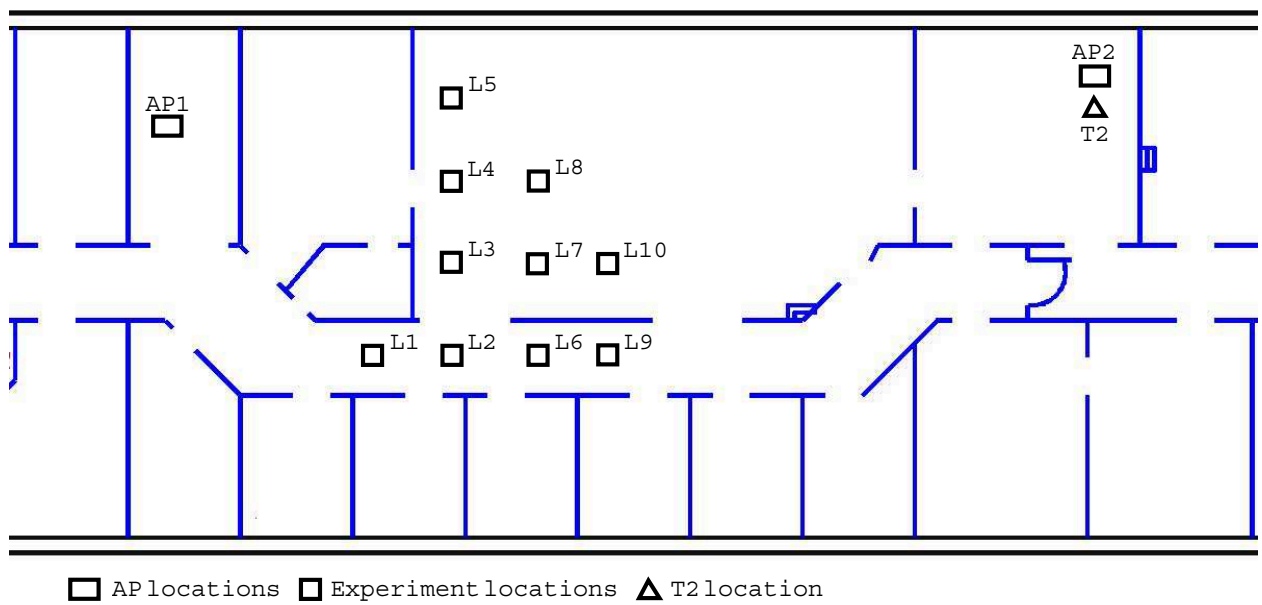

Fig. 6. Floor plan of the experiment environment.